

SERVICE MANUAL

ALBA

SYS 2850CD

▲BUSH

MN 204/205CD

+ GOODMAN'S MD-105

ALBA

▲BUSH

harvard

HiNARI

SPECIFICATIONS

Test Condition

- 1 Signal generators
 AM 50 ohm impedance with loop Antenna
 FM 50 ohm impedance open loop calibrated
 DUMMY LOADING BOX

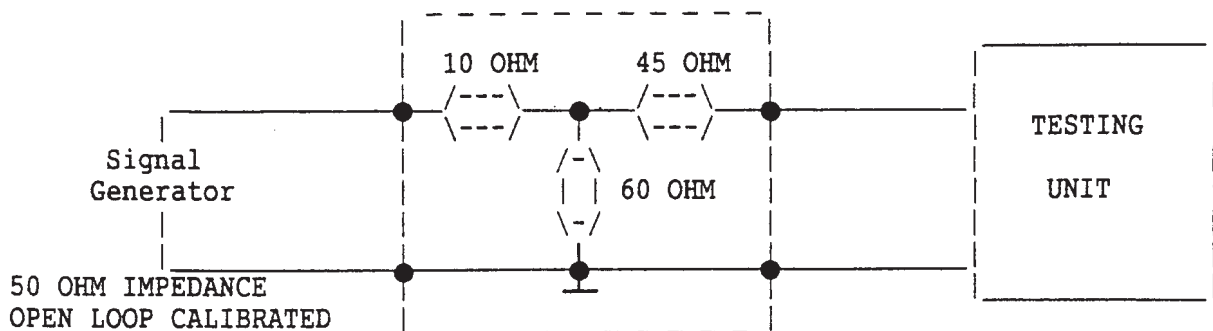

THE FM RF SIGNAL LEVEL AT THE ANTENNA OF THE TESTING UNIT IS EQUAL TO THE SIGNAL GENERATOR READING MINUS 12dB.

- 2 Output Impedance R/L CH : 4 OHM
 3 Reference Output : 50 MW
 4 Supply Voltage : AC120v 60HZ /230V 50HZ.
 5 All measurements are taken at 25c +/- 3c
 6 Headphone Impedance :32 OHm
 7 Test Frequency List:
- | USA/CANADA | | EUROPE | |
|------------|-------|--------|-----|
| Mw1: | 520 | 522 | KHz |
| Mw2: | 610 | 612 | KHz |
| Mw3: | 1000 | 999 | KHz |
| Mw4: | 1400 | 1404 | KHz |
| Mw5: | 1710 | 1620 | KHz |
| Lw1: | -- | 150 | KHz |
| Lw2: | -- | 164 | KHz |
| Lw3: | -- | 218 | KHz |
| Lw4: | -- | 272 | KHz |
| Lw5: | -- | 285 | KHz |
| FM1: | 87.5 | 87.50 | |
| FM2: | 90.1 | 90.10 | |
| FM3: | 98.1 | 98.10 | |
| FM4: | 106.1 | 106.10 | |
| FM5: | 107.9 | 108.00 | |

SPECIFICATIONSMW Band

Modulation : AM 30% Mod. 400Hz

			<u>UNIT</u>	<u>NOMINAL</u>	<u>LIMIT</u>
1. Band Coverage			KHz	Mw1-Mw5	
2. Max. Sens. at 6 dB S/N	mw2	KHz	dB/M	50	56
	mw3	KHz	dB/M	50	56
	mw4	KHz	dB/M	50	56
3. S/N AT 74dB/M	mw2	KHz	dB	28	24
	mw3	KHz	dB	28	24
	mw4	KHz	dB	28	24
4. If Frequency	mw2	KHz	KHz	450	+2.5
5. If Rejection	mw2	KHz	dB	32	26
6. Image Rejection	mw4	KHz	dB	40	32
7. Auto Stop Sens.	mw3	KHz	dB/M	62	68
8. Auto Stop Accurate	mw3	KHz	KHz	0	+ ONE CHANNEL
9. 6 dB Band Width	mw3	KHz	KHz	6	4-8
10. ACA +- ONE CHANNEL	mw3	KHz	dB	24	18
11. Frequency Response Lower -6 dB Upper	mw3	KHz	Hz	50	100
			KHz	2.3	2
12. AGC at 100mV/m	mw3	KHz	dB	45	40
13. Out Put Distortion Mv 22.5KHz Dev	mw3	KHz	%	2.5	5
14. Tweet 2nd at 5mV/m 3rd at 5mV.m	If*2	KHz	%	5	10
	If*3	KHz	%	5	10

LW BAND

Modulation : AM 30% Mod. 400 Hz

				<u>UNIT</u>	<u>NOMINAL</u>	<u>LIMIT</u>
1. Band Coverage					KHz	Lw1-Lw5
2. Max. Sens. at 6 dB S/N	Lw2	KHz	dB/M	60	64	
	Lw3	KHz	dB/M	60	64	
	Lw4	KHz	dB/M	60	64	
3. S/N AT 74dB/M	Lw3	KHz	dB	20	16	
4. If Frequency	Lw2	KHz	KHz	450	+2.5	
5. If Rejection	Lw2	KHz	dB	32	26	
6. Image Rejection	Lw4	KHz	dB	32	20	
7. Auto Stop Sens.	Lw3	KHz	dB/M	64	72	
8. Auto Stop Accurate	Lw3	KHz	KHz	0	+ ONE CHANNE	

SPECIFICATIONSFM Band:

Modulation : Fm 22.5 KHz Dev. 1 KHz

		<u>UNIT</u>	<u>NOMINAL</u>	<u>LIMIT</u>
1. Band Coverage		MHz	FM1-FM5	
2. Max. Sens. at 6 dB S/N	FM2 MHz	dB	14	20
	FM3 MHz	dB	14	20
	FM4 MHz	dB	14	20
3. Quieting Sens. at 30 dB S/N	FM2 MHz	dB	20	26
	FM3 MHz	dB	20	26
	FM4 MHz	dB	20	26
4. If Frequency	FM2 MHz	MHz	10.7	+100KHz
5. If Rejection	FM2 MHz	dB	50	40
6. Image Rejection	FM4 MHz	dB	25	18
7. Auto Stop Sens.	FM3 MHz	dB	34	40
8. 3 dB Limiting	FM3 MHz	dB	24	30
9. S/N at 1mV	FM3 MHz	dB	40	35
10. Frequency Response Lower -6 dB w/Pre-em (50us/75us)	FM3 MHz	Hz	50	100
		KHz	10	8
11. Distortion at 1 mV 22.5 KHz Dev	FM3 MHz	%	2	4
12. Overload Distortion at 100 mV 75 KHz Dev.	FM3 MHz	%	3.5	6

FM Stereo Band :

Modulation : FM 75 KHz Dev. 1 KHz L 45% R 45% Pilot 10%

		<u>UNIT</u>	<u>NOMINAL</u>	<u>LIMIT</u>
1. Stereo Separation	FM3 MHz	dB	30	20
2. Stereo Indication Sens.	FM3 MHz	dB	30	36

SPECIFICATIONSTAPE CASSETTE

Play Back

			<u>UNIT</u>	<u>NOMINAL</u>	<u>LIMIT</u>
1. Tape Speep	3KHz	STT-111N	%	+0.5	+3/-2
2. Wow & Flutter		STT-111N	%	0.25	0.35
3. Channel Separation		STT-141N	dB	35	30
4. Crosstalk		STT-121N	dB	40	30
5. Frequency Response	Normal	125Hz	dB	± 0	± 6
		8KHz	dB	± 0	± 6
6. Distortion	1KHz	STT-118N	%	2	3.5
7. S/N Ration	1KHz	STT-112BN	dB	45	40
8. Min Volume Hum.			mV	1	3
9. Max. Volume Hum.			mV	50	80

Recording

			<u>UNIT</u>	<u>NOMINAL</u>	<u>LIMIT</u>
1. Recording Bias System				AC :	
2. Erasing System				AC	
			dB	40	45
3. Distortion			%	4	6
4. Frequency Response	Normal	125Hz	dB		± 6
		6.3KHz			± 6

SPECIFICATIONSAudio

	<u>CONDITION</u>	<u>UNIT</u>	<u>NOMINAL</u>	<u>LIMIT</u>
1. (Preset Equalizer)				
a. CLASSIC	100Hz		0	+1.5
	400Hz		0	+1.5
	6.3KHz		0	+1.5
	10KHz		-1	+1.5
b. ROCK	100Hz		+5	+1.5
	400Hz		+3	+1.5
	6.3KHz		+2.5	+1.5
	10KHz		+3.5	+1.5
c. JAZZ	100Hz		-1.5	+1.5
	400Hz		-2.5	+1.5
	6.3KHz		+4	+1.5
	16KHz		-0	+1.5
2. LEVEL MATCHING				
a. CD -10dB 1KHz		dB	0	
b. FM 40 KHz dev		dB		+3
c. TAPE 0 dB 1KHz		dB		+3
3. Output Power 10%	EI-57	W	3.5	3
Fm 75KHz 1KHz				
4. Output Power MAX	EI-57	W	4	3.5
Fm 75KHz 1KHz				

OPTION:

5. Output Power 10%	EI-66	W	4.5	4.0
Output Power Max.	EI-66	W	5	4.5

CD

1. FREQ. RESP	100Hz VS 1KHz	dB	-3	-6
	10KHz VS 1KHz	dB	-3	-6
2. THD. 1KHz -10dB		%	1.0	2
3. CHANNEL BALANCE	1KHz	dB	0.5	3
4. SEPARATION	1KHz	dB	—	30
5. S/N		dB	—	55

SPECIFICATIONS

(FOR PCB-12)

*TEST CONDITION

1. Equipment : Panasonic Audio Analyzer (VP-7723A)
2. Test disc : A-BEX Test CD (TCD-782)
3. Loading : Without loading
4. Operating Voltage : DC 8.6V \pm 10% / 400 mA

The following specification are assured only when the secondary Voltages of the power supply are within specification

ITEM	TEST DISC	MIN	STANDARD	MAX	REMARKS
Output Level	TCD-782	0.9Vrms	1.1Vrms		Specification at 1 KHz, 0dB
Harmonic Distortion	TCD-782		0.06%	0.11%	Specified at 1 KHz measurement of signal that has gone through LPF(20KHz)
S/N Ratio	TCD-782	85dB	92dB		Specified at 1 KHz measured after audio corrector filtering (JIS-A) & LPF(20KHz)
Frequency Response	TCD-782				Set to 0 dB at 1 KHz
20 Hz		-2 dB	0 dB	+2 dB	
100 Hz		-1 dB	0 dB	+1 dB	
10 KHz		-3 dB	0 dB	+2 dB	
Interruption correction	TCD-725A	>0.7mm	>0.8mm		
Black Dot defect Correction	TCD-725A	>0.6mm	>0.8mm		
Finger Print Correction	TCD-725A		>65um		
Deflection (Vertical Deviation)	TCD-731R	0.6mm	0.8mm		
Scratch defect Correction	TCD-721	0.6mm	0.8mm		

ALIGNMENT

MODEL : GW-3892

MW SECTION						
STEP	ALIGNMENT FREQ	TEST EQUIPMENT	SIGNAL-IN	SIGNAL-OUT	ADJUST	REMARK
1	450 KHz	(1)AM IF SWEEP GEN. WITH LOOP ANTENNA. (2)ALIGNMENT OSCILLOSCOPE	LET THE MW ANT COIL CLOSE TO MW GEN.ANTENNA	TAKE OUT THE SIGNAL FROM PIN 9 OF IC002	ADJUST IFT101 103TO GET MAX T103 OUTPUT AT 450 KHz	(1)BAND SW.IN MW POSITION (2)VOL.CONTROL AT MIN POSITION (3)TUNE TO HIGH END.
2	522 KHz	(1)MW SWEEP GEN. WITH ANT. (2)ALIGNMENT OSCILLOSCOPE	SAME AS STEP 1.	SAME AS STEP 1.	ADJUST IFT002 TO HAVE 1.2V +/-0.1V AT C030 TO GND	PRESS BUTTON TO LOW END.
3 REPEAT STEP 1,2 UNTIL NO FURTHER IMPROVEMENT CAN BE MADE.						
4	1404 KHz	SAME AS STEP 2.	SAME AS STEP 1.	SAME AS STEP 1.	ADJUST TC025 TO GET MAX. OUTPUT AT 1404KHz	PRESS BUTTON TO 1404KHz
5	612 KHz	ADJUST MW-ANT COIL TO GET MAX. OUTPUT AT 612KHz	SAME AS STEP 2.	SAME AS STEP 1.	SAME AS STEP 2.	SAME AS STEP 1.
6 REPEAT STEP 5,6 UNTIL NO FURTHER IMPROVEMENT CAN BE MADE.						

ALIGNMENT

FM SECTION						
STEP	ALIGNMENT FREQ.	TEST EQUIPMENT	SIGNAL-OUT	SIGNAL-OUT	ADJUSTMENT	REMARK
1	IF 10.7 MHz	(1)FM IF SWEEP GENERATOR (2)ALIGNMENT OSCILLOSCOPE	INJECT THE IF SWEEP SIGNAL THROUGH 5Pf CAPACITOR TO R003	SIGNAL ARE TAKEN OUT FROM PIN OF IC002	ADJUST IFT001 AND IFT102 REPEAT TO GET BEST "S" CURVE AT 10.7 MHz	(1)BAND SW.IN FM POSITION (2)VOL.CONTROL IN MIN. (3)TUNE TO HIGH END.
2	87.5 MHz	SAME AS STEP 2.	SAME AS STEP 2.	SAME AS STEP 1.	ADJUST L002 TO HAVE READING 1.3V +0.2V AT C030 TO GND	TUNE TO LOW END
3 REPEAT STEP 1,2 UNTIL NO FURTHER IMPROVEMENT CAN BE MADE						
4	106.1 MHz	SAME AS STEP 2.	SAME AS STEP 2.	SAME AS STEP 1.	ADJUST TC29 TO GET MAX. OUTPUT.	PRESS BUTTON TO 106.1MHz
5	90.1 MHz	SAME AS STEP 2.	SAME AS STEP 2.	SAME AS STEP 1.	ADJUST L001 TO GET MAX. OUTPUT	PRESS BUTTON TO 90.1MHz
6 REPEAT STEP 5,6 AND THEN STEP 5,6 UNTIL NO FURTHER IMPROVEMENT CAB BE MADE.						
7	98.1MHz	(1)OSCILLOSCOPE (2)COUNTER WITH X10 PROBE		SIGNAL ARE TAKEN OUT FROM PIN 12 OF IC 701	ADJUST VR701 TO GET 19KHz OUTPUT	(1)BAND SW IN FM STEREO POSITION (2)PRESS BUTTON TO 98.1MHz

ALIGNMENT

LW SECTION						
STEP	ALIGNMENT FREQ	TEST EQUIPMENT	SIGNAL-IN	SIGNAL-OUT	ADJUST	REMARK
1	150 KHz	(1)LW SWEEP GEN. WITH ANT. (2)ALIGNMENT OSCILLOSCOPE (3)DVM	LET THE LW ANT COIL CLOSE TO LW GEN.ANTENNA	TAKE OUT THE SIGNAL FROM PIN 9 OF IC002	ADJUST TC028 TO HAVE 1.2V AT C030 TO GND	(1)BAND SW. IN LW POSITION (2)VOL.CONTROL AT MIN POSITION (3)TUNE TO LOW END.
2	285 KHz	SAME AS STEP 1.	SAME AS STEP 1.	SAME AS STEP 1.	CHECK VOLTAGE AT C030 TO GND 7.5-8V	PRESS BUTTON TO HIGH END.
3	REPEAT STEP 1,2 UNTIL NO FURTHER IMPROVEMENT CAN BE MADE.					
4	272 KHz	SAME AS STEP 1.	SAME AS STEP 1.	SAME AS STEP 1.	ADJUST TC30 TO GET MAX. OUTPUT AT 272KHz	PRESS BUTTON TO 272KHz
5	164 KHz	SAME AS STEP 1.	SAME AS STEP 1.	SAME AS STEP 1.	ADJUST LW ANT COIL TO GET MAX. OUTPUT AT 164KHz	PRESS BUTTON TO 164KHz
6	REPEAT STEP 4,5 UNTIL NO FURTHER IMPROVEMENT CAN BE MADE.					

TAPE DECK SECTION						
STEP	ALIGNMENT FREQ	TEST EQUIPMENT	SIGNAL-IN	SIGNAL-OUT	ADJUST	REMARK
1		(1)COUNTER (2)OSCILLOSCOPE	TEST TAPE STT-111N (OR MIT-111N) 3KHz	SPEAKER OUTPUT	ADJUST VR130 TO HAVE 3KHz +30/-5Hz AT SPEAKER OUTPUT	(1)FUNCTION SW. IN TAPE POSITION (2)VOL. ADJUSTED TO REF. OUTPUT. (3)AT NORMAL SPEED POSITION
2		SAME AS STEP 1.	TEST TAPE 8KHz	SAME AS STEP 1.	ADJUST TAPE HEAD SCREW TO GET MAX.OUTPUT	SAME AS STEP 1.
3		SAME AS STEP 1.	TEST TAPE 8KHz	SAME AS STEP 1.	CHECK FREQUENCY OUTPUT 4.2KHz- 4.5KHz AT SPEAKER OUTPUT	(1)FUNCTION SW. IN TAPE POSITION (2)VOL. ADJUSTED TO REF. OUTPUT. (3)AT HI-SPEED POSITION

CD ALIGNMENT (FOR PCB-12)

CONNECTION

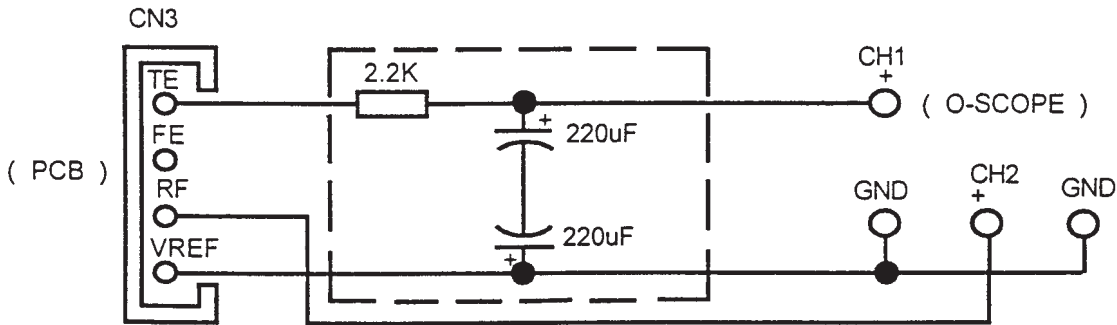

* PROBE : 10 X 1.

(A) PRE ADJUSTMENT

1. Make VR2 (TB), VR4 (FEB) 30 Deg.

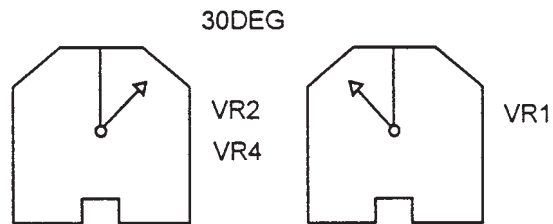

(B) TRACKING BALANCE

1. Select "CH1" of Scope as connection.
2. Voltage DIV : 2mV, Time DIV : 5ms.
3. Set the mode " GND" and make the level "0 mV".
4. Set the mode "DC".
5. Play the disc YEDA-18 or TCD 782.
6. Search the 1 st and last track continuously.
7. Adjust VR2(TB) untill the level is 0 +-5mV during search.

(C) FOCUS ERROR BALANCE (RF LEVEL ADJUST)

1. Select " CH2" of scope as connection.
2. Voltage DIV : 20mV, Time DIV : 0.2us.
3. Set the mode " AC".
4. Play TNO 10 of YEDS-18 or TCD 782.
5. Adjust VR4 (FEB) untill RF level is max.

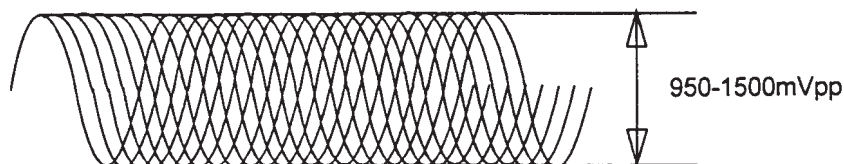

CD ALIGNMENT (FOR PCB-12)

(D) FOCUS OFFSET

1. Select " CH2" of scope as connection.
2. Voltage DIV : 50mV , Time DIV : 2ms.
3. Set the mode " DC".
4. Play the cleanest track of test disc.
5. Adjust VR1 (FOF) untill getting the correct wave form.
6. Make the trigger sure till fixed wave form.

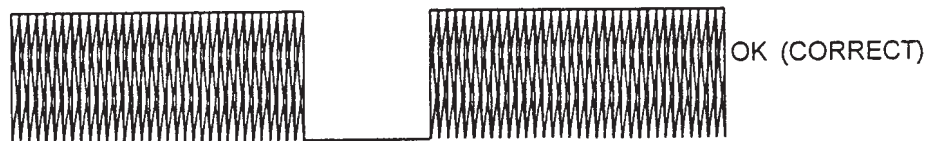

*TEST DISC

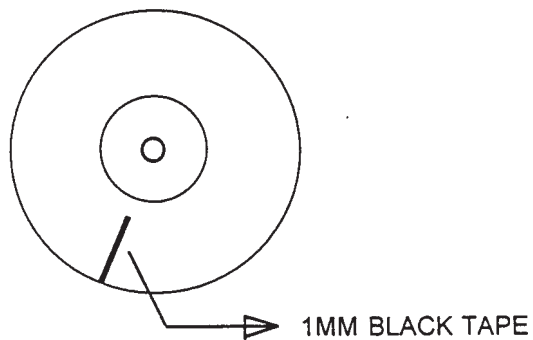

FUNCTION LIST

(FOR PCB-12)

General Operation

Open/Close Press once to open the door, Press once again to Close the door.

Press the PLAY/PAUSE (▶▶||) button.

Result : The first on the disc is played and track number is displayed.

To stop the playback temporarily, press the PLAY/PAUSE (▶▶||) button.

➤ Press PLAY/PAUSE (▶▶||) again to continue playing the disc.

To start playing at the beginning of... Then press...

The next track	SKIP/SEARCH ▶▶ once
The current track	SKIP/SEARCH ◀◀ once
The previous track	SKIP/SEARCH ◀◀ twice
The track of your choice	SKIP/SEARCH ◀◀ or ▶▶ the appropriate number of times

To search through the tracks... Then hold down...

Forwards	SKIP/SEARCH ▶▶ until you reach the required point
Backwards	SKIP/SEARCH ◀◀ until you reach the required point

➤ You are advised to turn the volume down before using this function.
Press the STOP (•) button when you have finished.

Random Play

Random Button Press once Press the Play Button to play the disc in random order.

Program Play

Up to 20 tracks

Press the MEMORY/PROGRAM

Select a desired track by using the Skip Buttons.

Press the MEMORY/PROGRAM Button to enter the track into the program.

Press PLAY/PAUSE Button to play the disc

Press STOP Button to terminate program play.

Repeat Play

Single Track Repeat Play

Press M-UP/REPRAT Button twice.

The display will show a flashing "REPEAT"

All Tracks Repeat Play

Press M-UP/REPEAT Button once.

The display will show "REPEAT"

TROUBLE SHOOTING GUIDE (FOR CD PLAYER)
(FOR PCB-12)

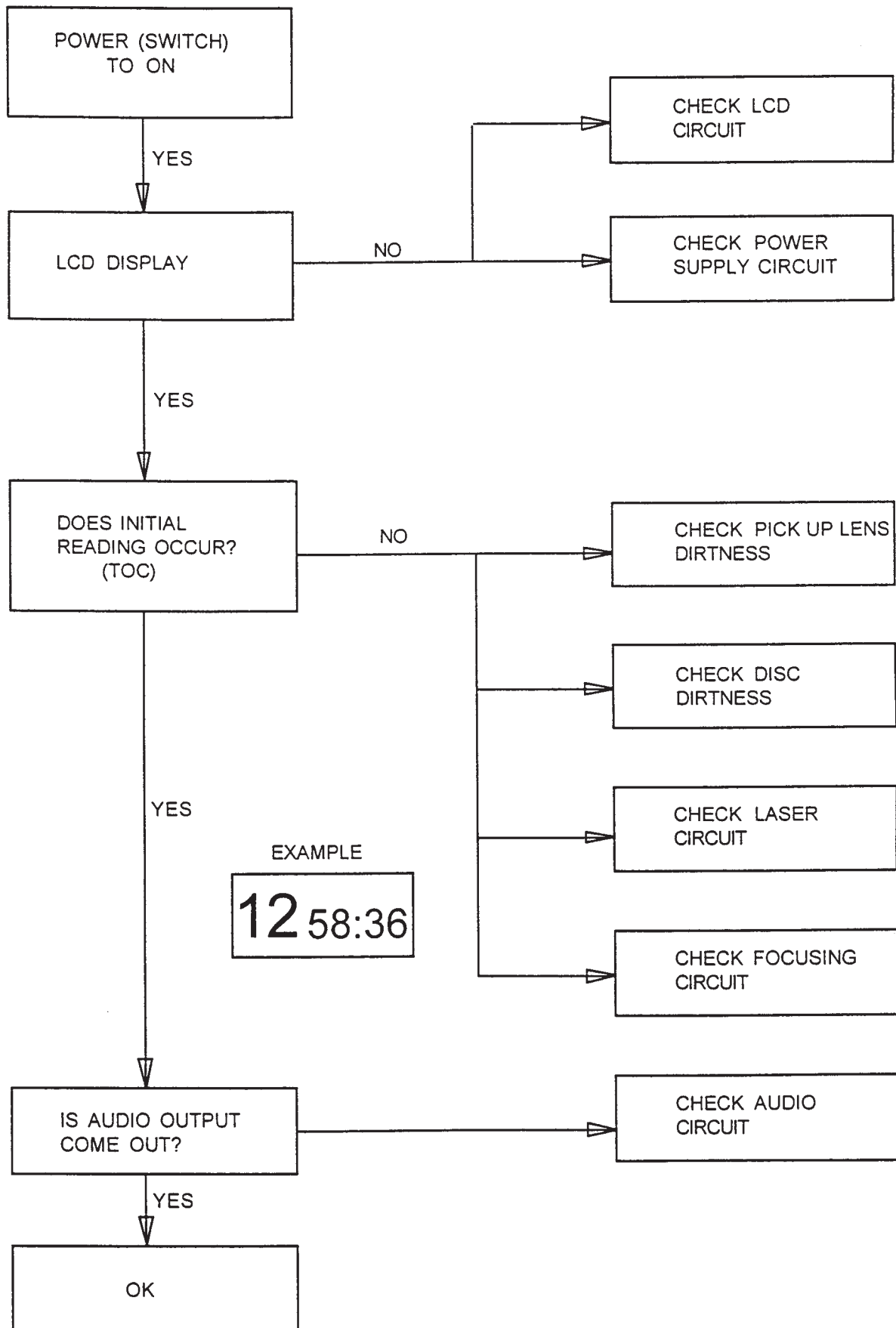

IF LASER IS EMITTING LIGHT
(FOR PCB-12)

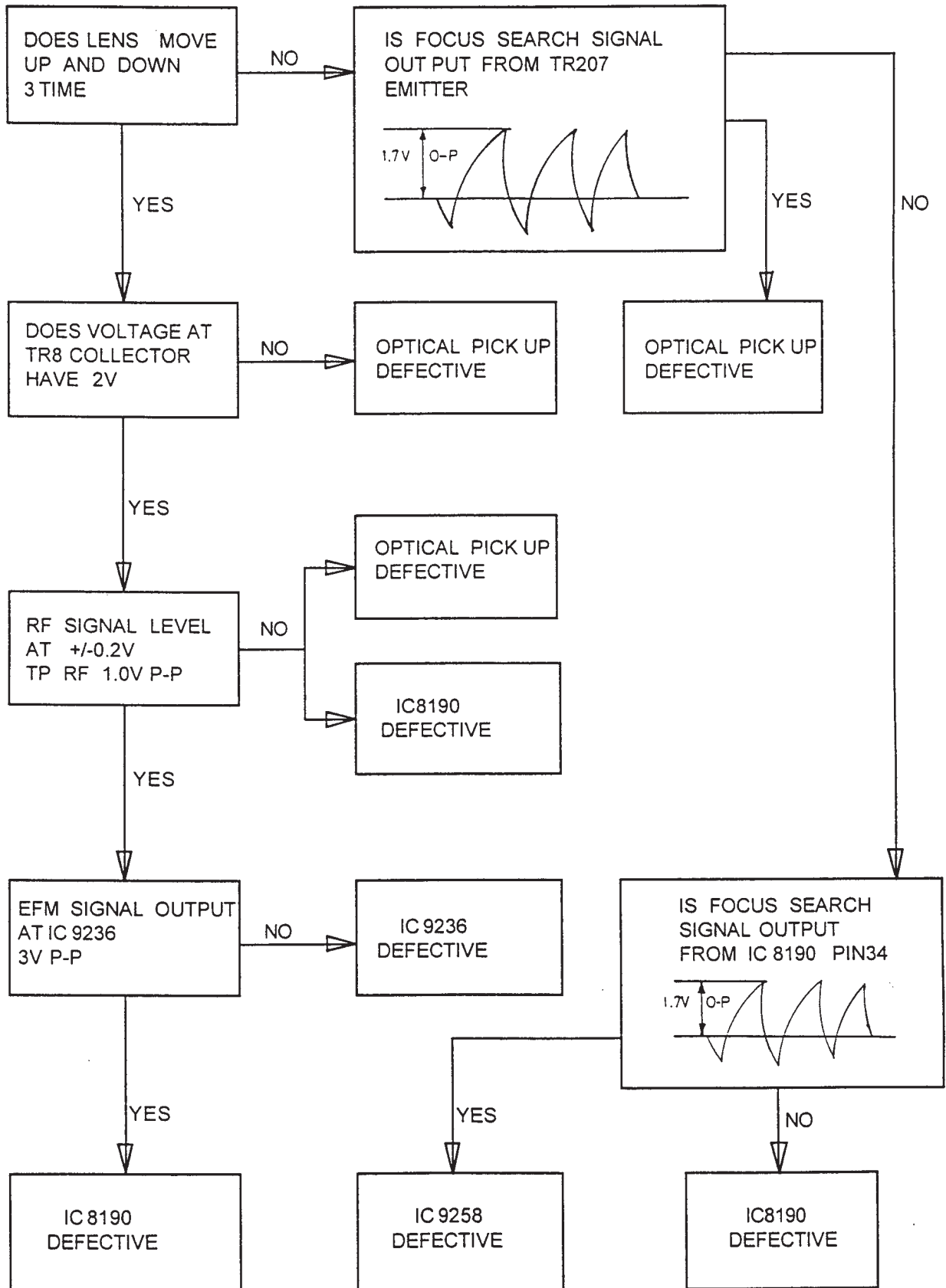

IF LASER IS NOT EMITTING LIGHT
(FOR PCB-12)

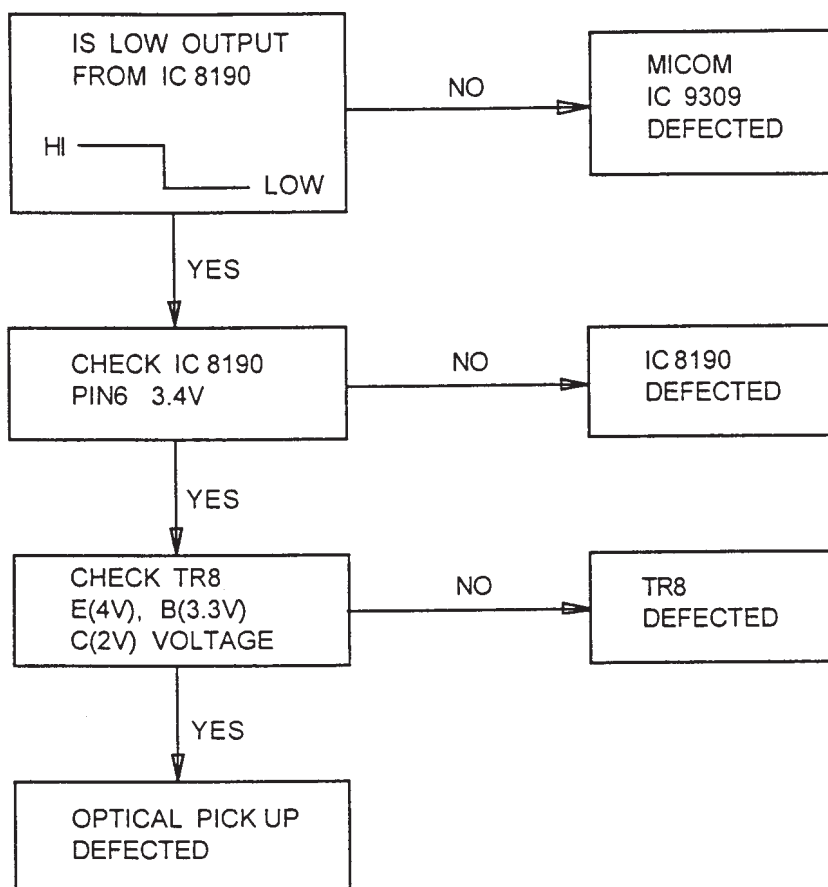

IF DISC IS NOT MOVING
(FOR PCB-12)

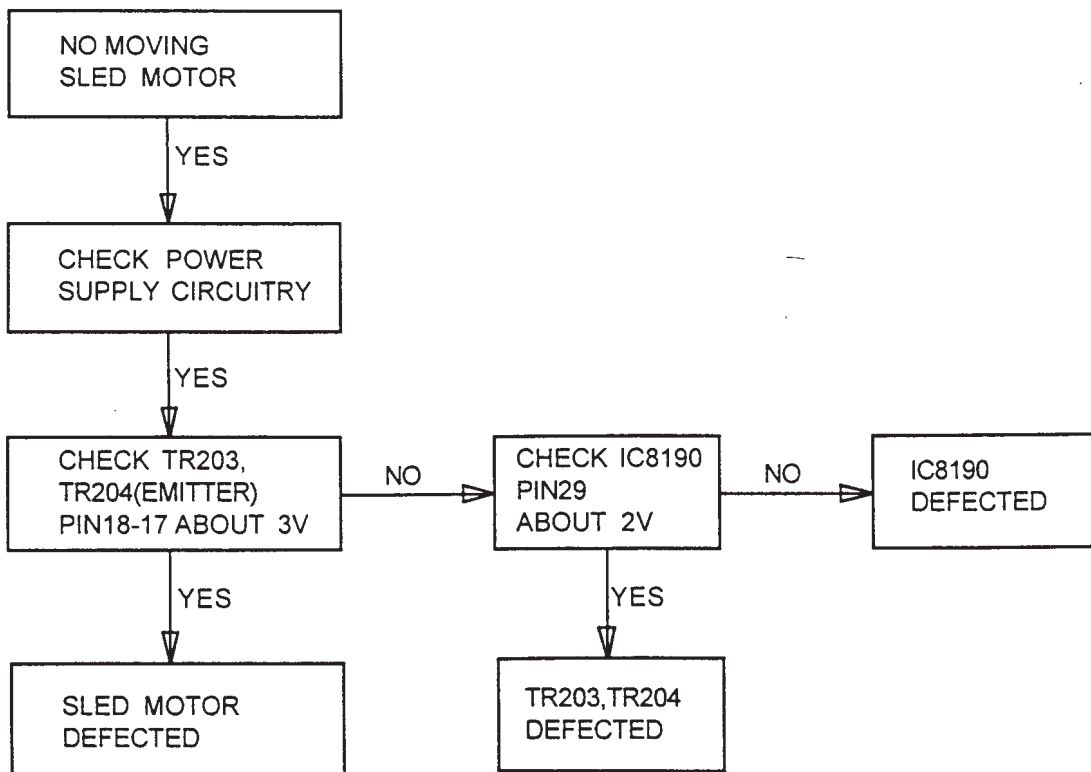
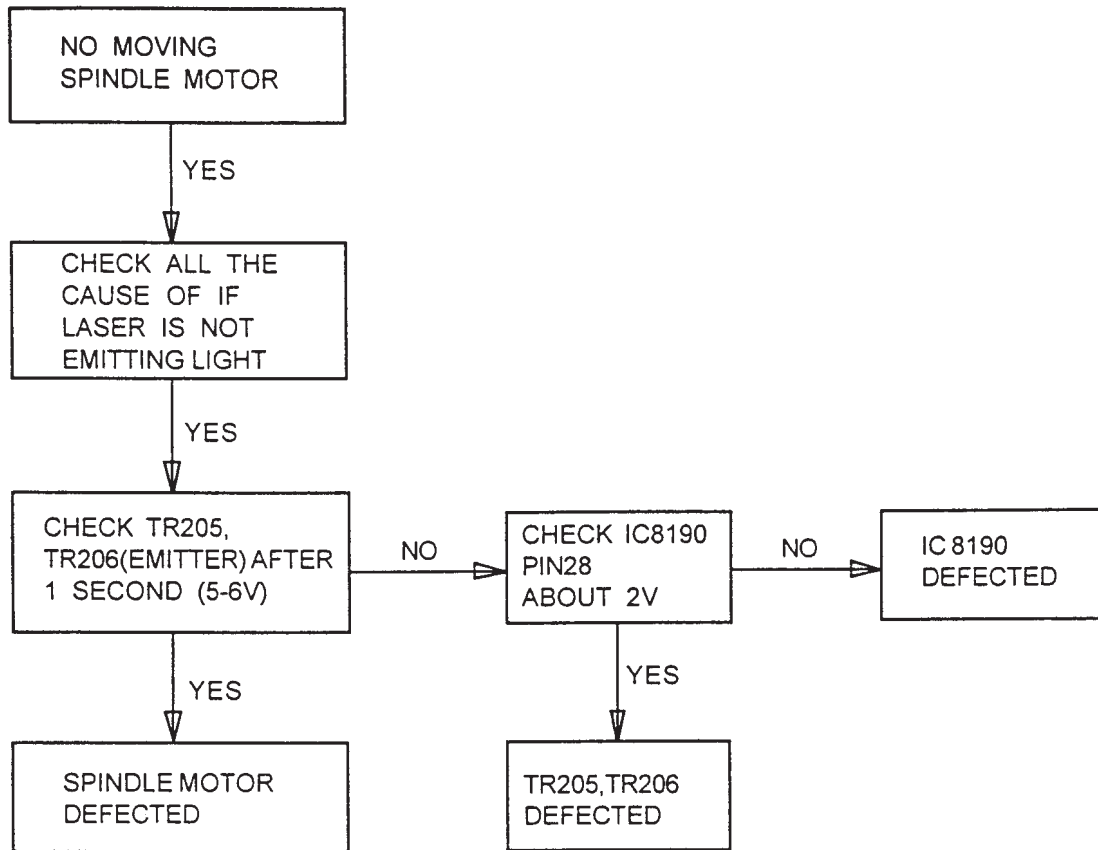

AUDIO CIRCUIT CHECK (FOR PCB-12)

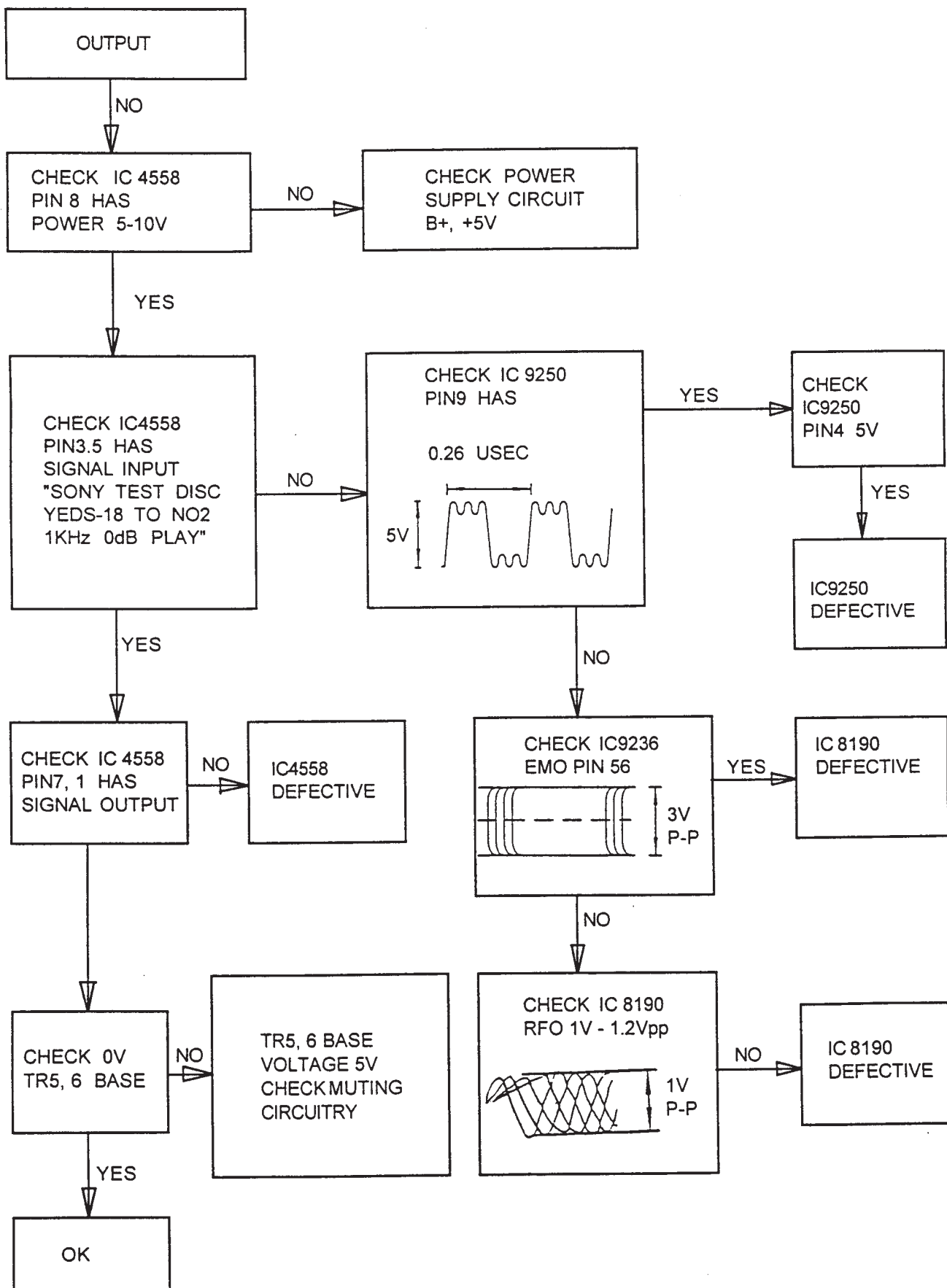

CD BLOCK DIAGRAM

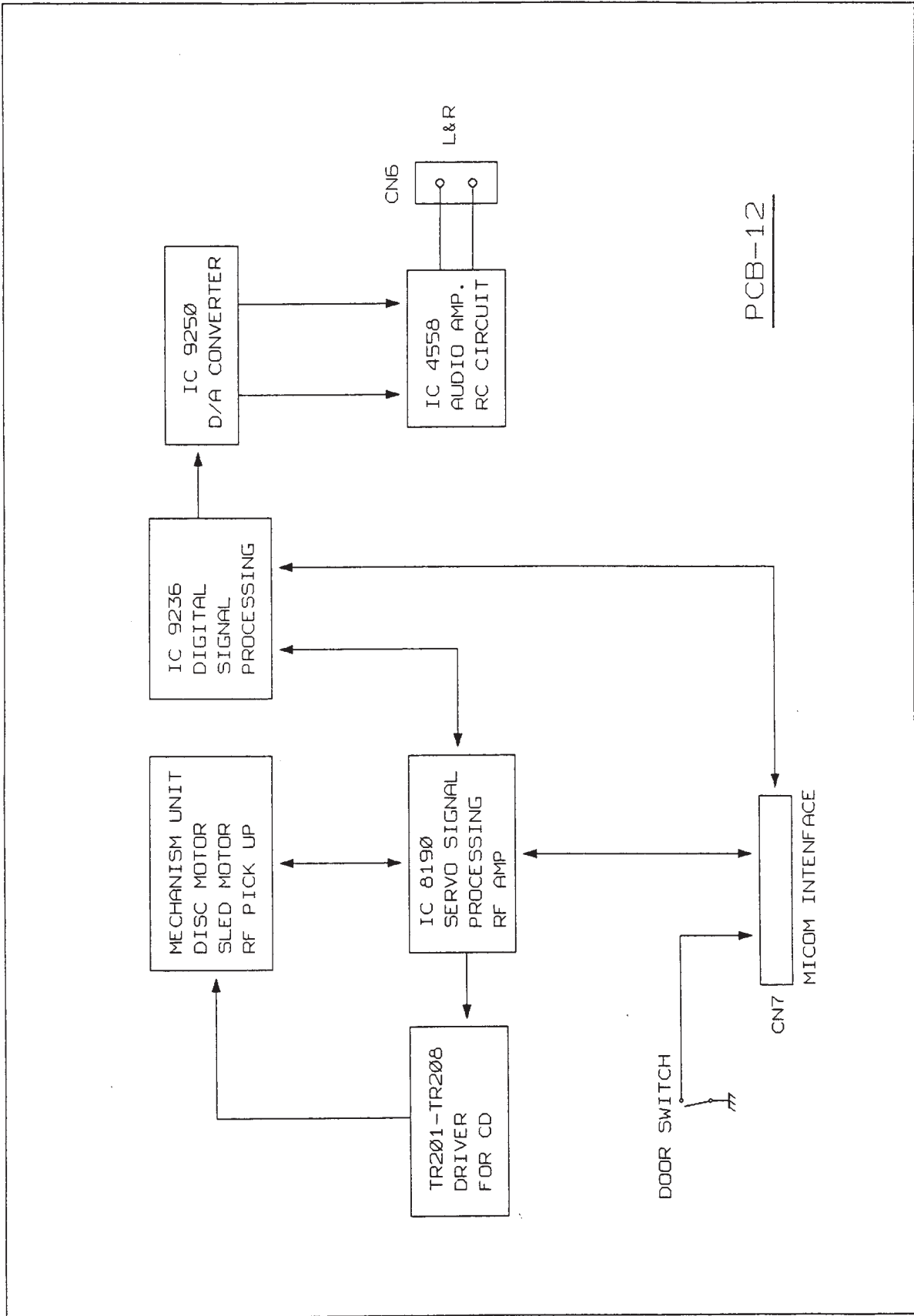

CONNECTION OF CD MECHANISM
(FOR PCB-12)

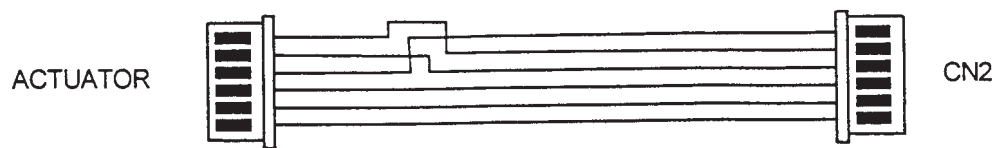
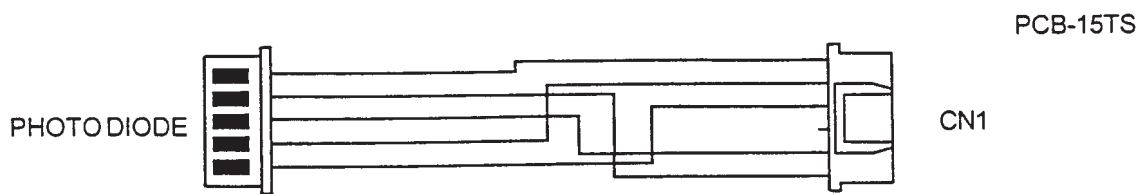
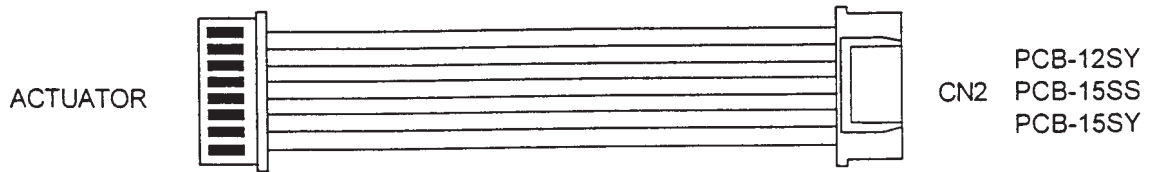

This page is intentionally left blank

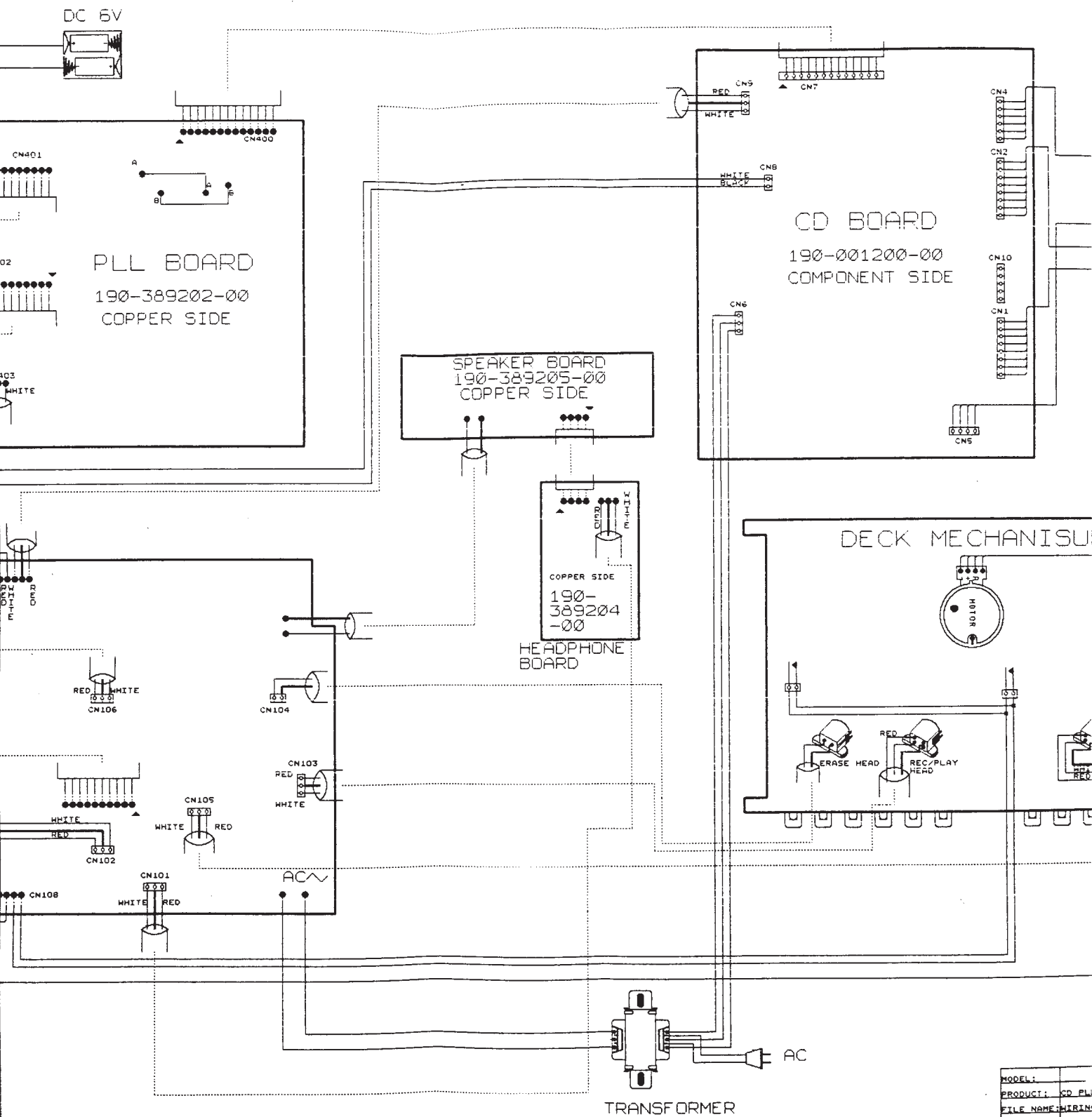

MODEL:	
PRODUCT:	CD PL
FILE NAME:	WIRIN
SHEET:	1 OF
CHECK:	

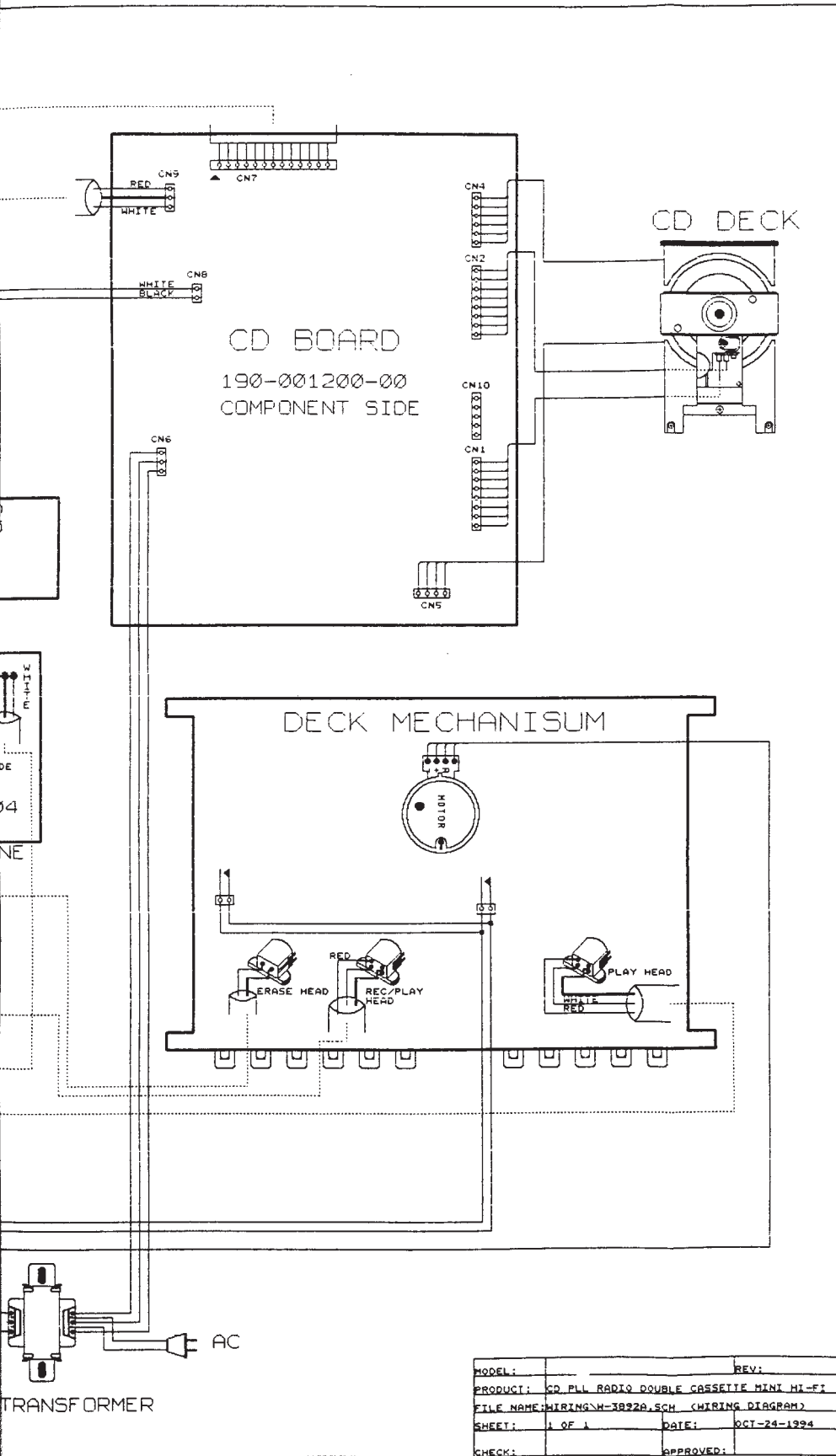

MODEL:	REV:
PRODUCT: CD PLL RADIO DOUBLE CASSETTE MINI HI-FI	
FILE NAME: WIRING W-3822A.SCH (WIRING DIAGRAM)	
SHEET: 1 OF 1	DATE: OCT-24-1994
CHECK:	APPROVED:

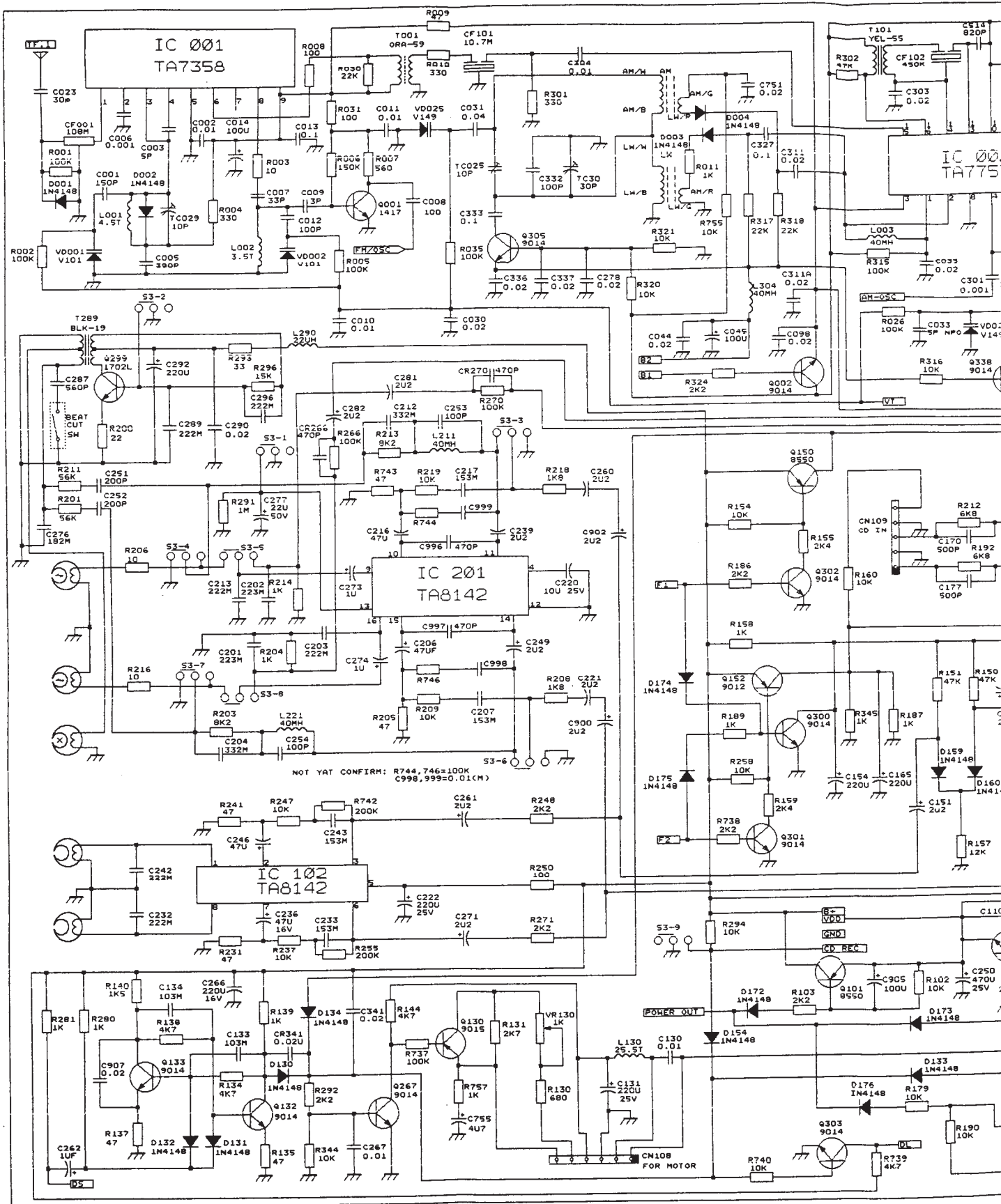

SYSTEM2850CD

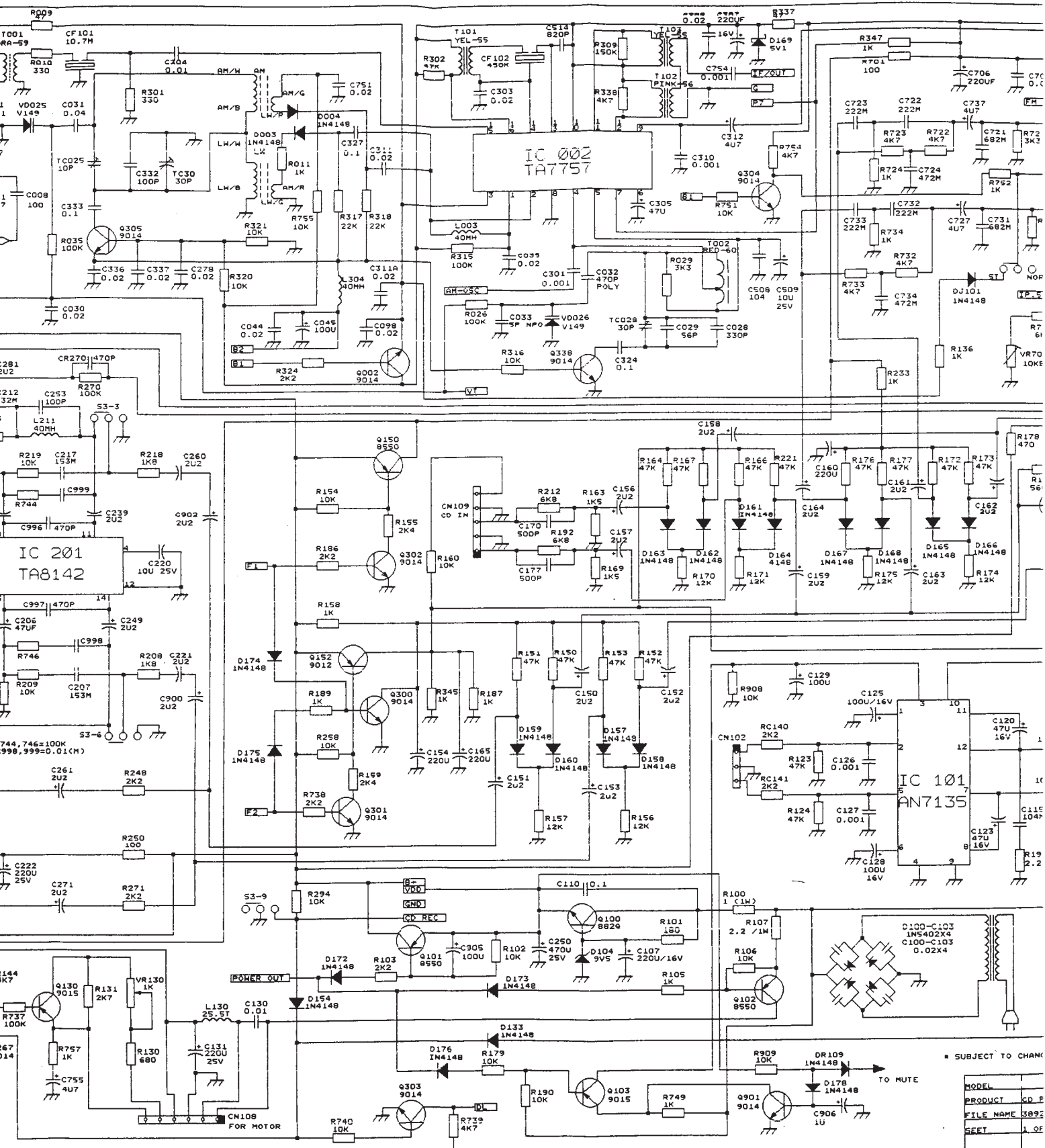

* SUBJECT TO CHANGE
 MODEL _____
 PRODUCT _____
 FILE NAME 13892
 SEET 1 OF _____
 CHECK G. L.

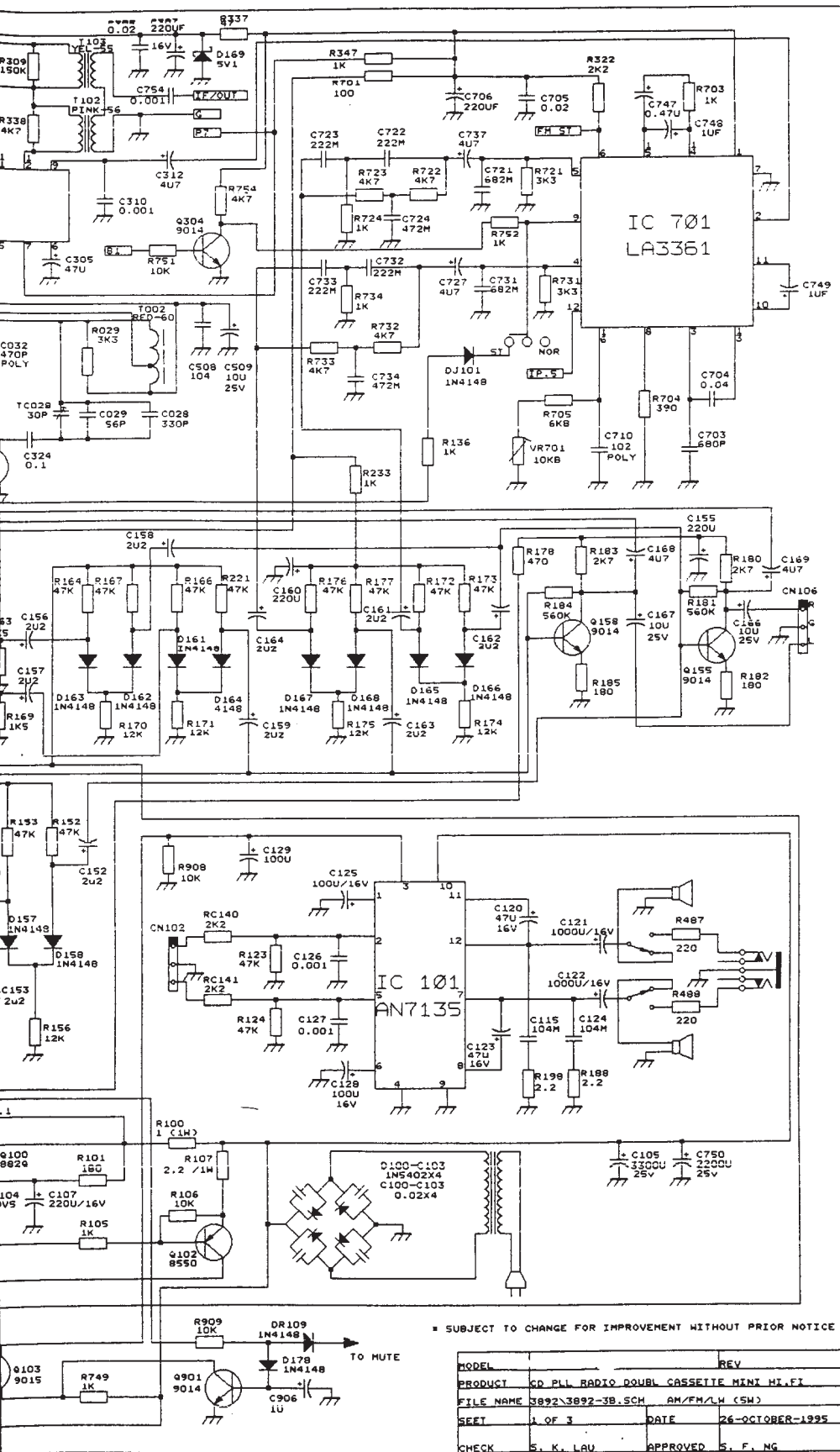

MODEL	REV
PRODUCT	CD PLL RADIO CASSETTE MINI HI-FI
FILE NAME	3892\3892-3B.SCH AM/FM/LM (5W)
SHEET	1 OF 3 DATE 26-OCTOBER-1995
CHECK	S. K. LAU APPROVED S. F. NG

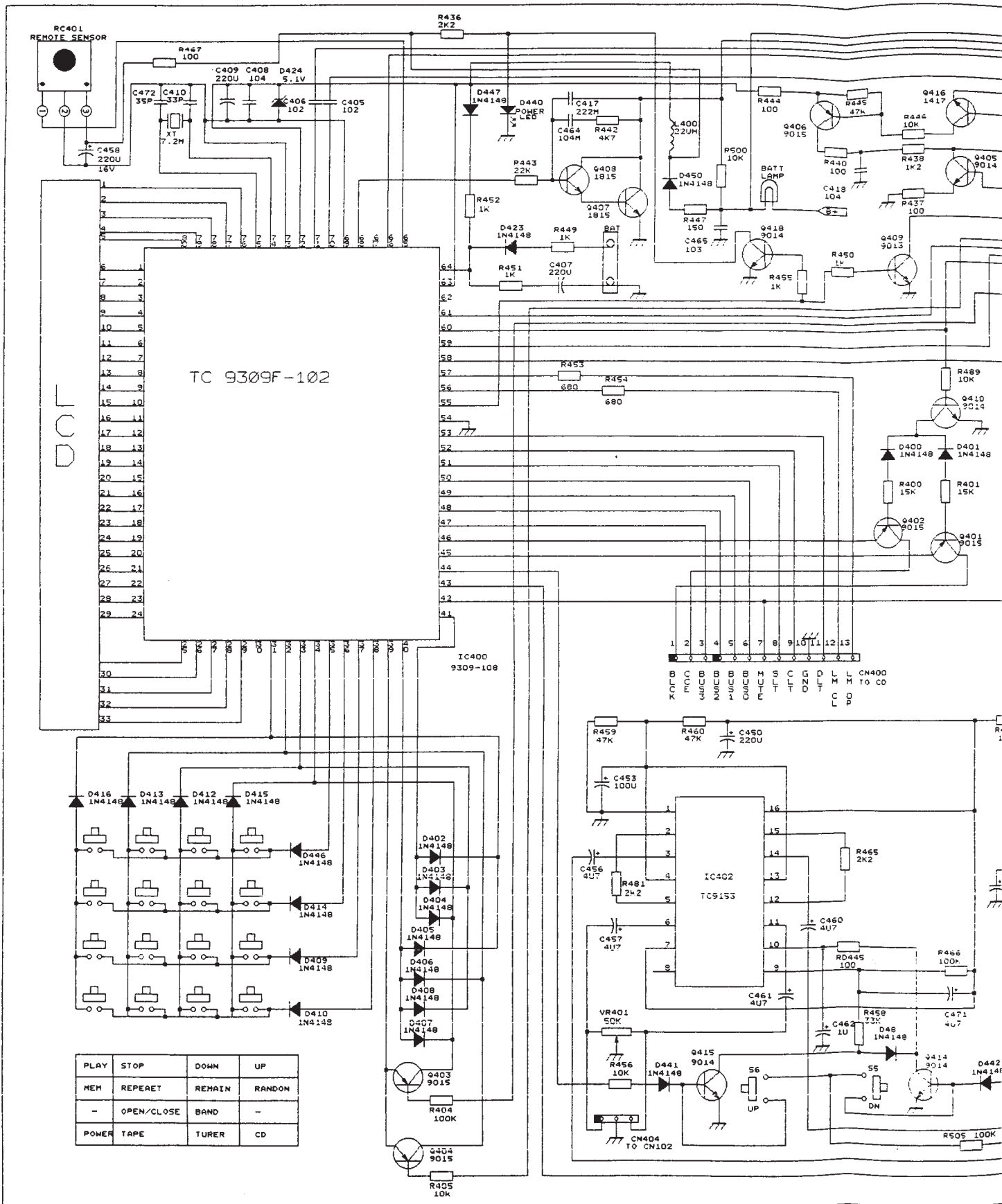

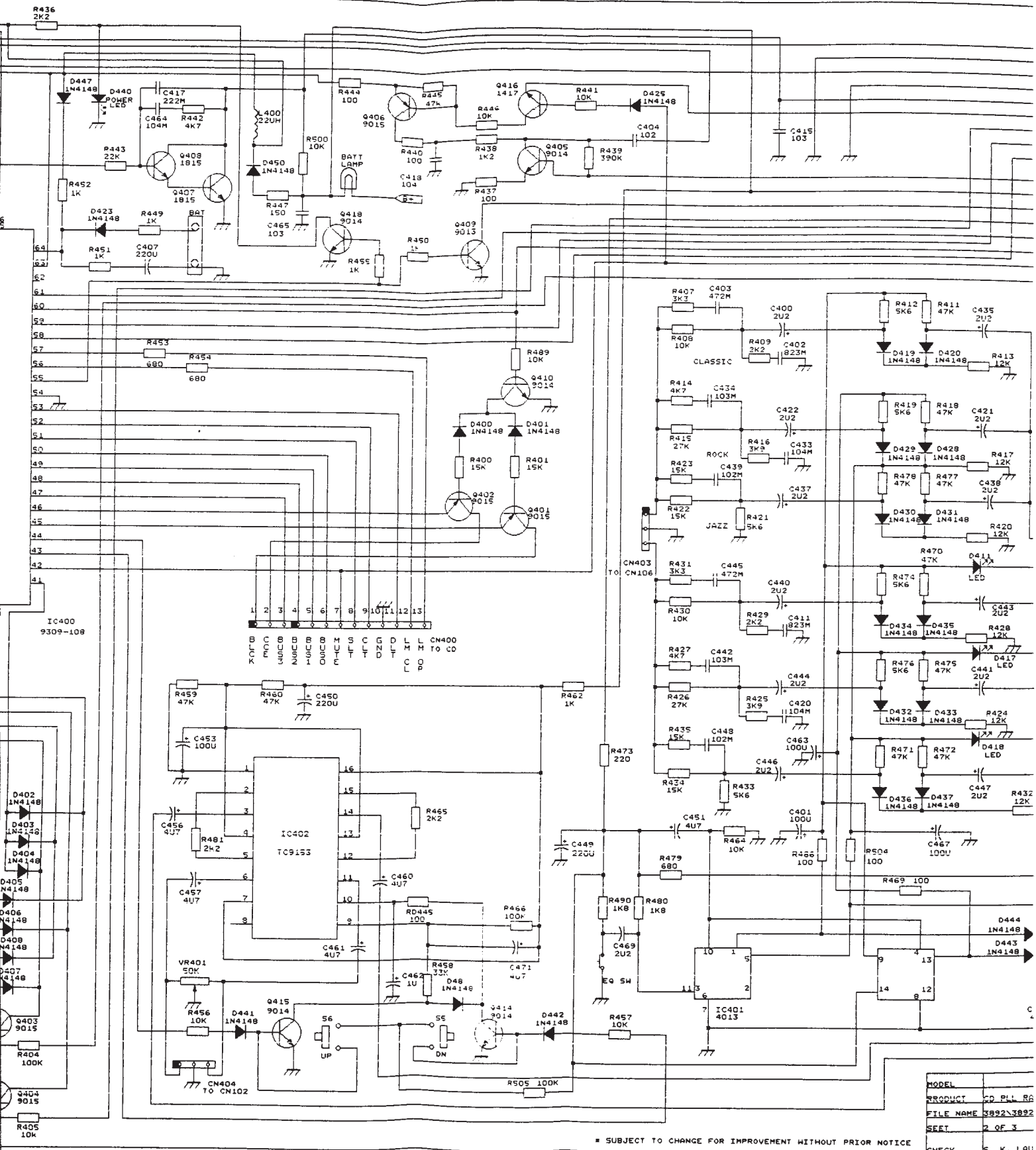

• SUBJECT TO CHANGE FOR IMPROVEMENT WITHOUT PRIOR NOTICE

MODEL	
PRODUCT	SD PLI RA
FILE NAME	38923892
SHEET	2 OF 3
CHECK	S. K. LAW

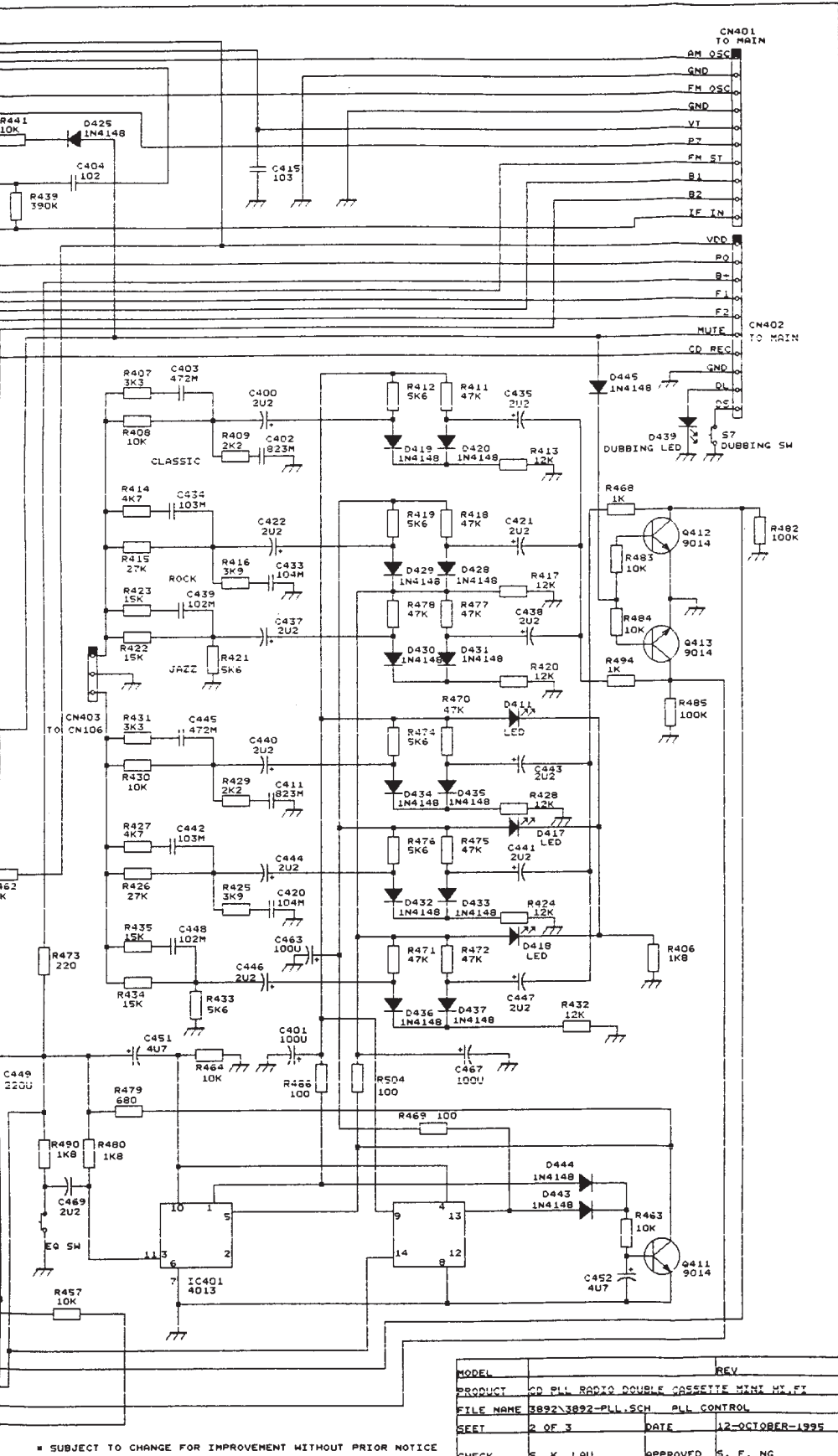

* SUBJECT TO CHANGE FOR IMPROVEMENT WITHOUT PRIOR NOTICE

MODEL	REV
PRODUCT	CD PLL RADIO DOUBLE CASSETTE MINI HI-FI
FILE NAME	3892\3892-PLL.SCH ALL CONTROL
SHEET	2 OF 3
DATE	12-OCTOBER-1995
CHECK	S. K. LAU
APPROVED	S. F. NG

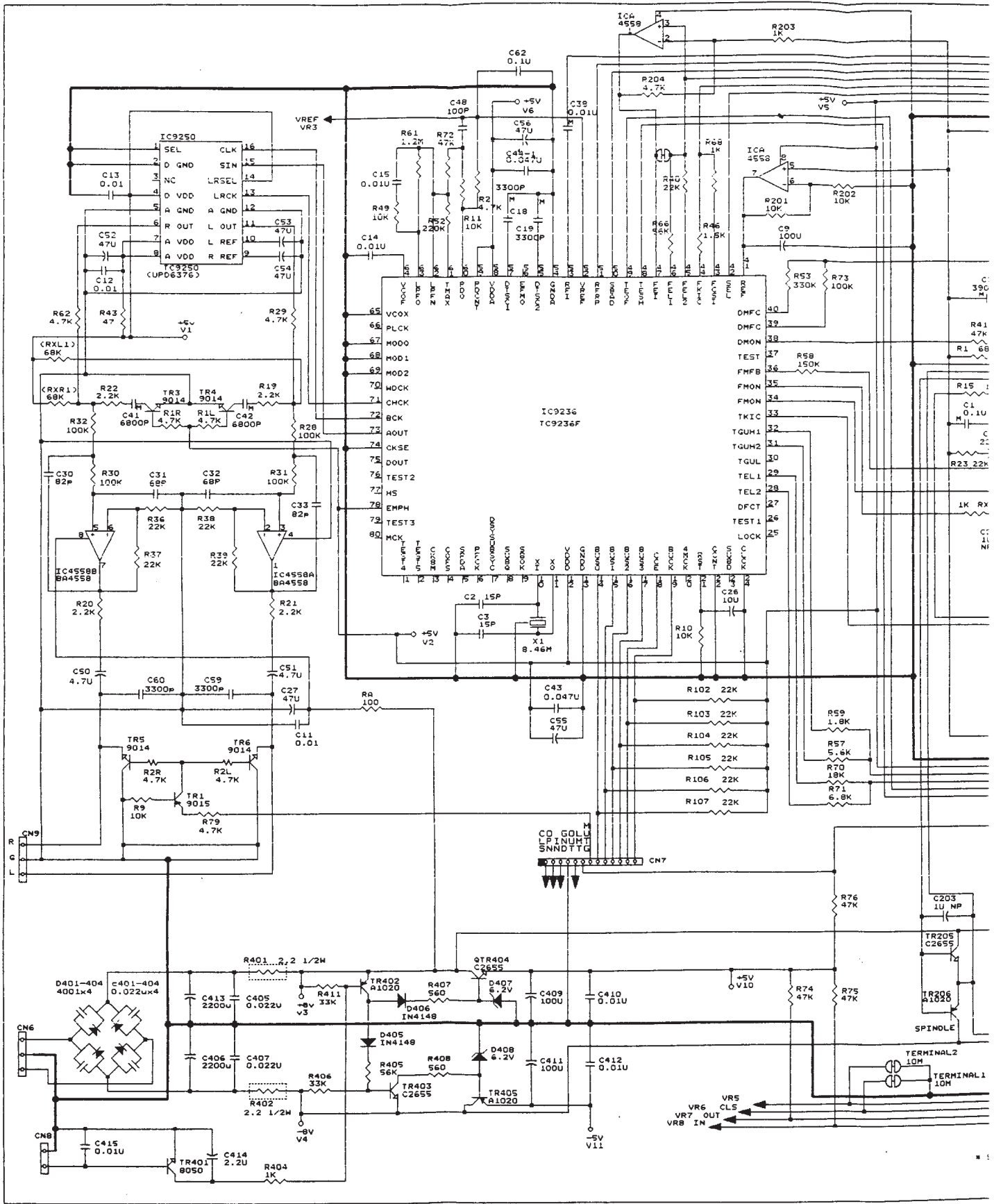

SYSTEM2850CD

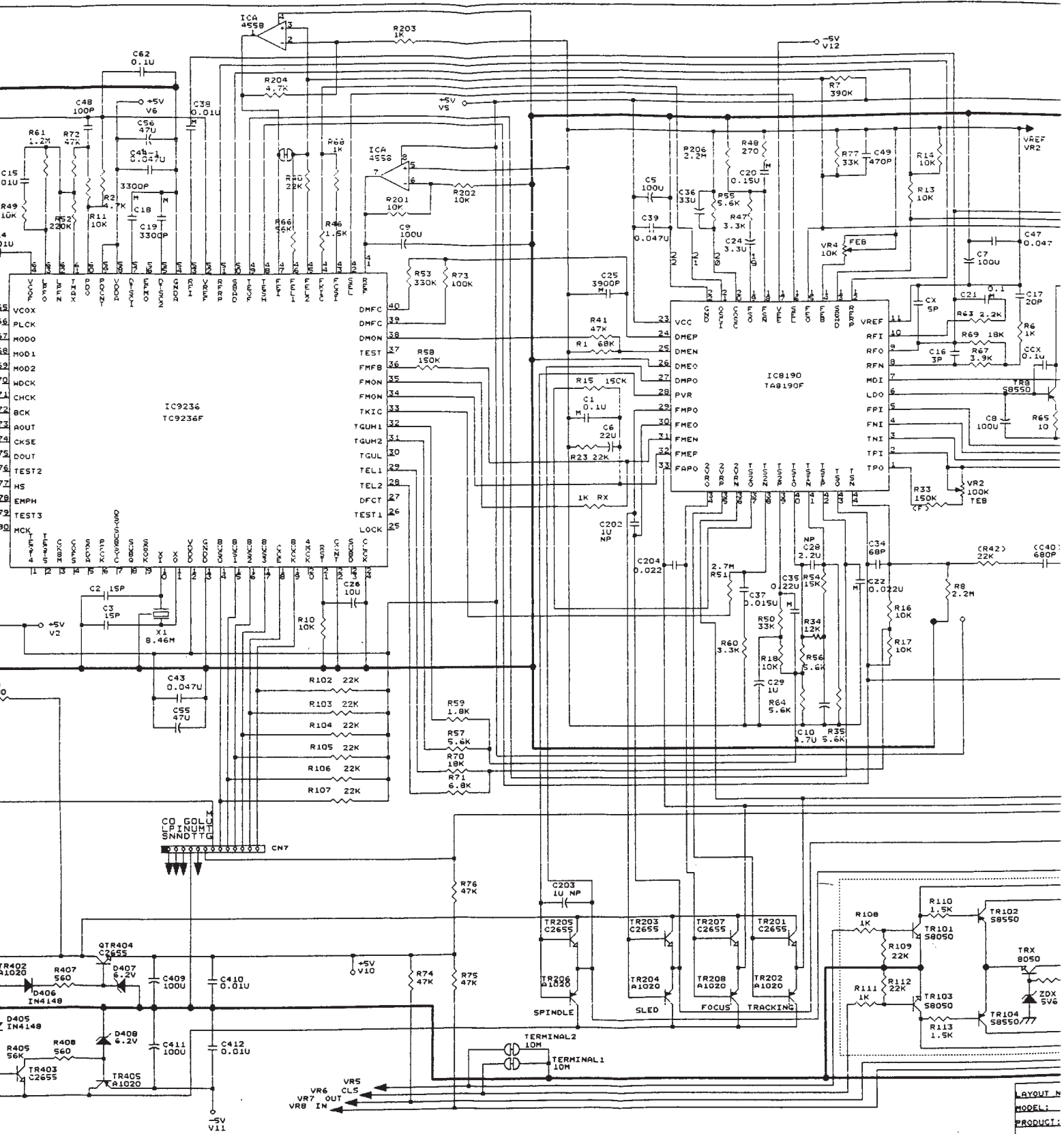

* SUBJECT TO CHANGE FOR MOVEMENT WITHOUT PRIOR NOTICE

LAYOUT N
 MODEL:
 PRODUCT:
 FILE NAM
 SHEET:
 CHECK:

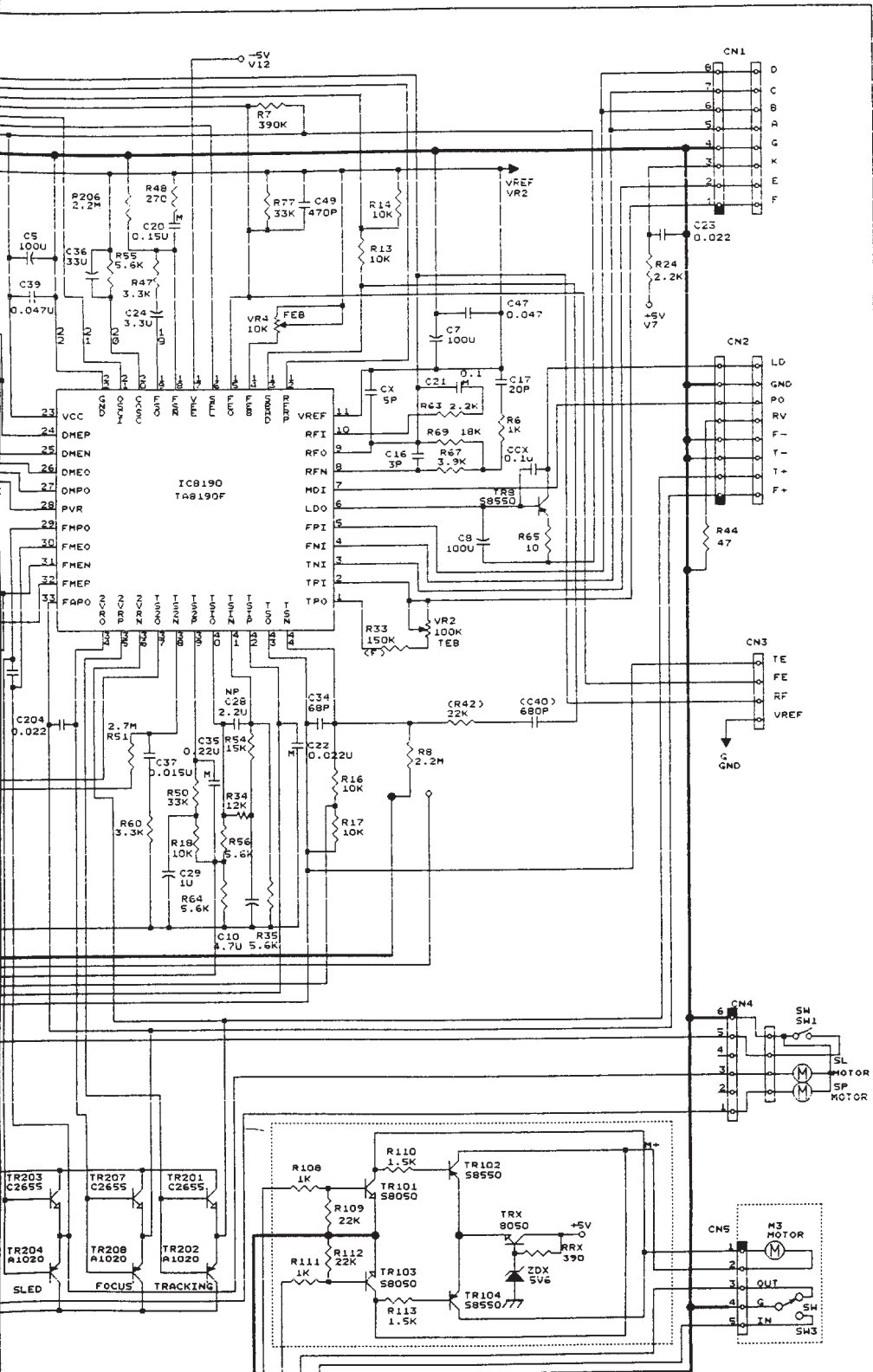

OBJECT TO CHANGE FOR MOVEMENT WITHOUT PRIOR NOTICE

LAYOUT NO:		REV:
MODEL:	PCB125Y	
PRODUCT:	CD PLAYER	
FILE NAME:	CD\PCB\PCB125Y.SCH (FOR SONY P/U)	
SHEET:	1 OF 1	DATE: 11-JULY-1995
CHECK:	G.L.CHAN	APPROVED: TANK HOO

REMOTE SCHEMATIC DIAGRAM

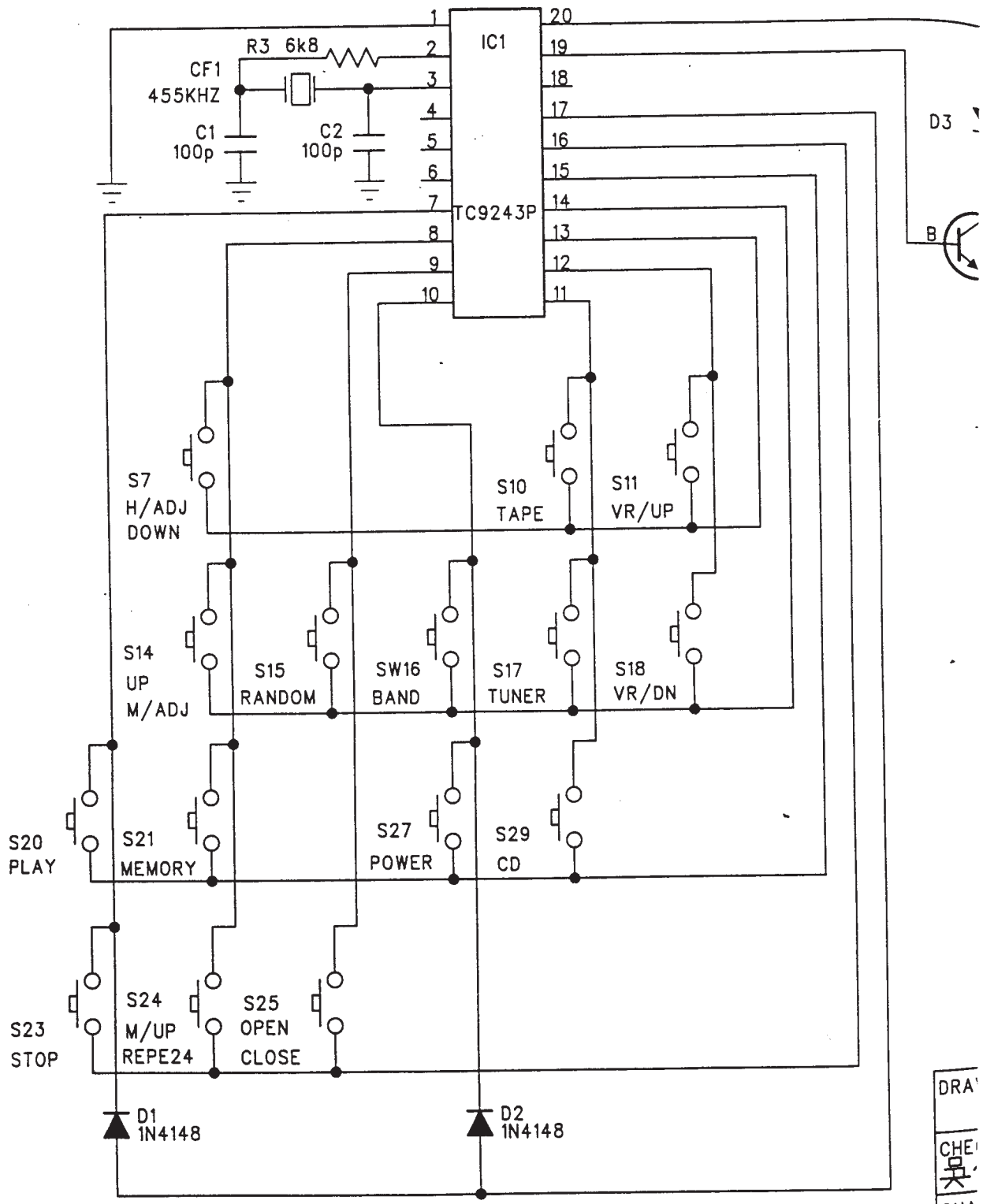

D3



DRA

CHE
QUA

REL

RAM

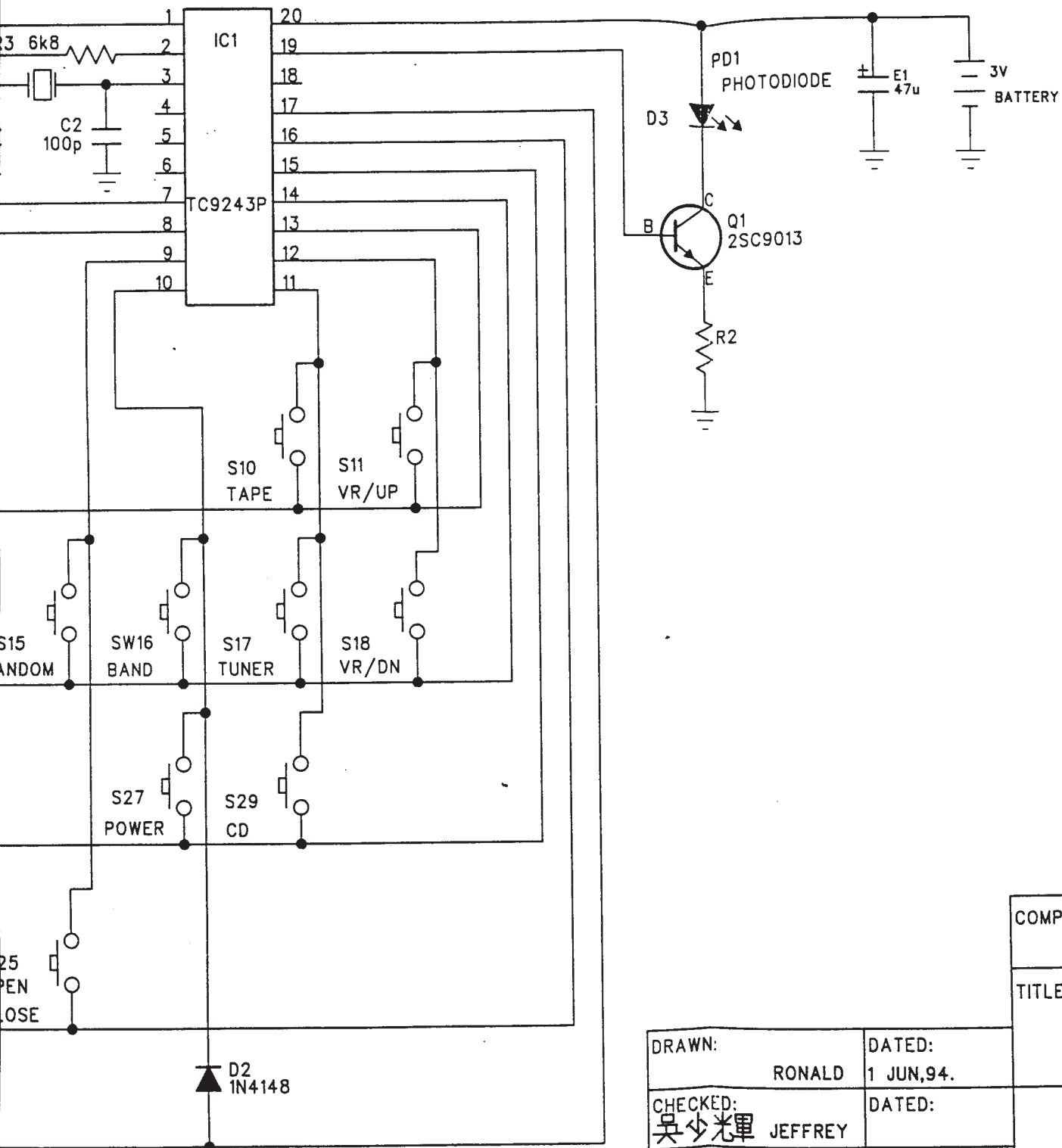

DRAWN: RONALD		DATED: 1 JUN,94.		COMPANY:
CHECKED: 吳少輝 JEFFREY		DATED:		
QUALITY CONTROL:		DATED:		CODE:
RELEASED:		DATED:		

F

REVISION RECORD			
LTR	ECO NO:	APPROVED:	DATE:

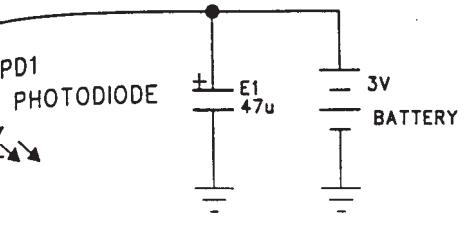

Q1
2SC9013

R2

COMPANY:			
TITLE: REMOTE HANDSET			
DESIGNED: RONALD	DATED: 1 JUN,94.	CODE:	SIZE:
DESIGNED: 光輝 JEFFREY	DATED:	DRAWING NO: RC93	
CONTROL:	DATED:	SCALE:	SHEET: OF
DESIGNED:	DATED:		

COMPONENT LAYOUT

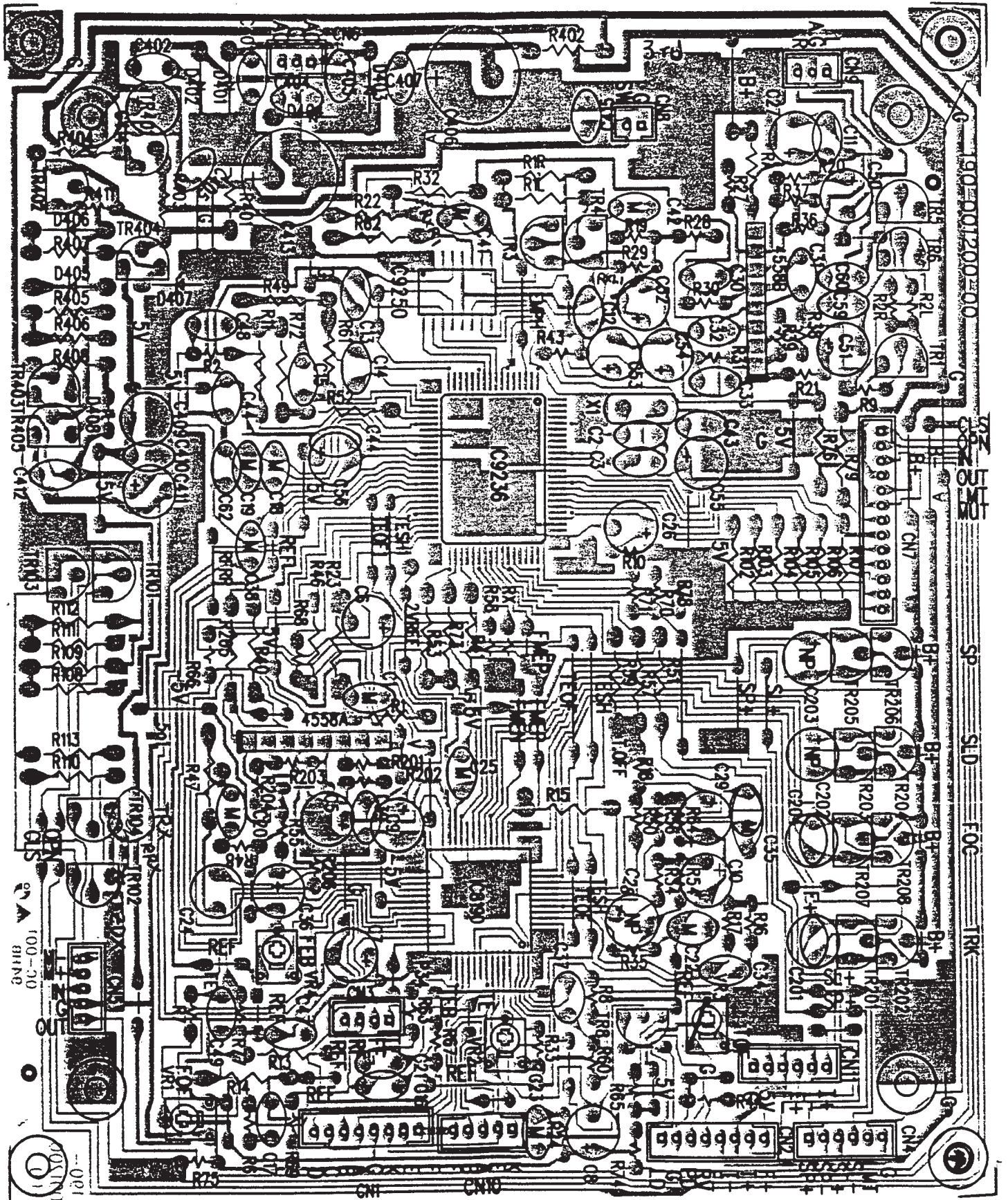

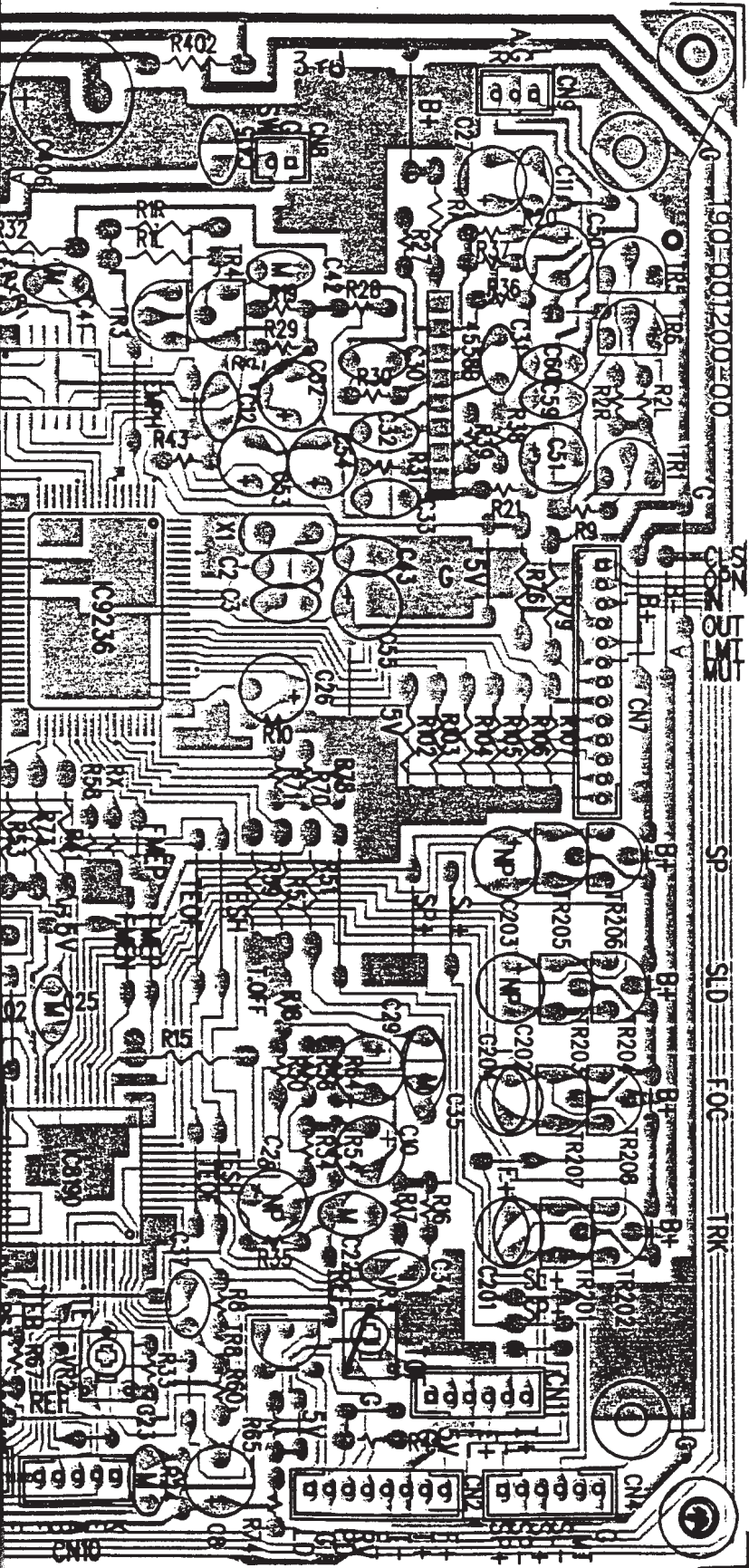

COMPONENT LAYOUT

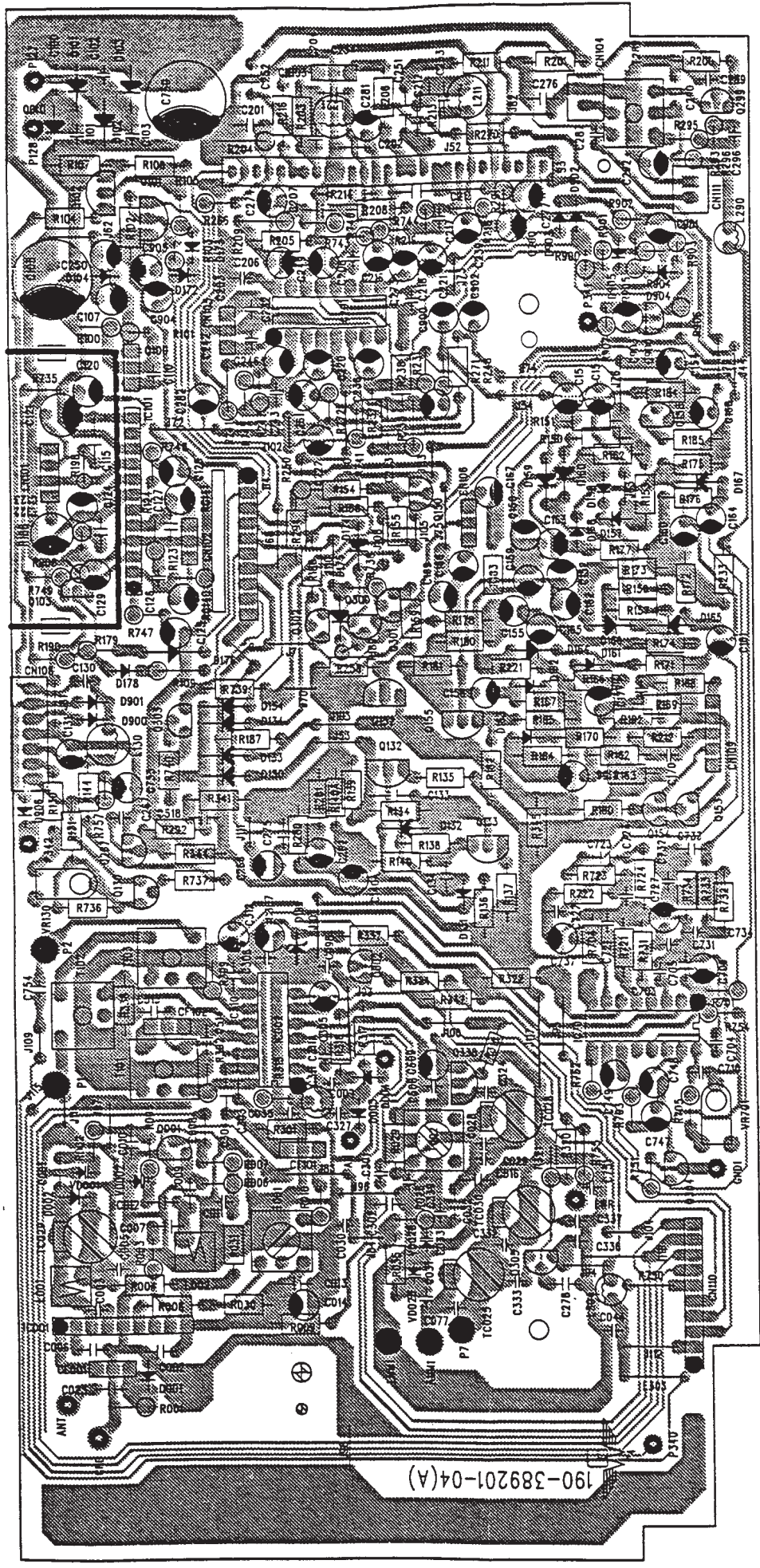

190-389201-04
MAIN PCB (FOR A,B,C)

190-389204-00
HEADPHONE BOARD

190-389205-00
SPEAKER BOARD

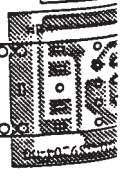
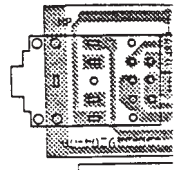
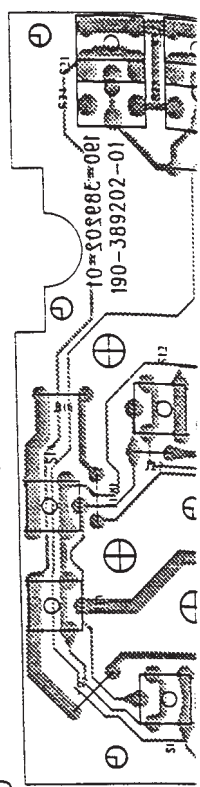

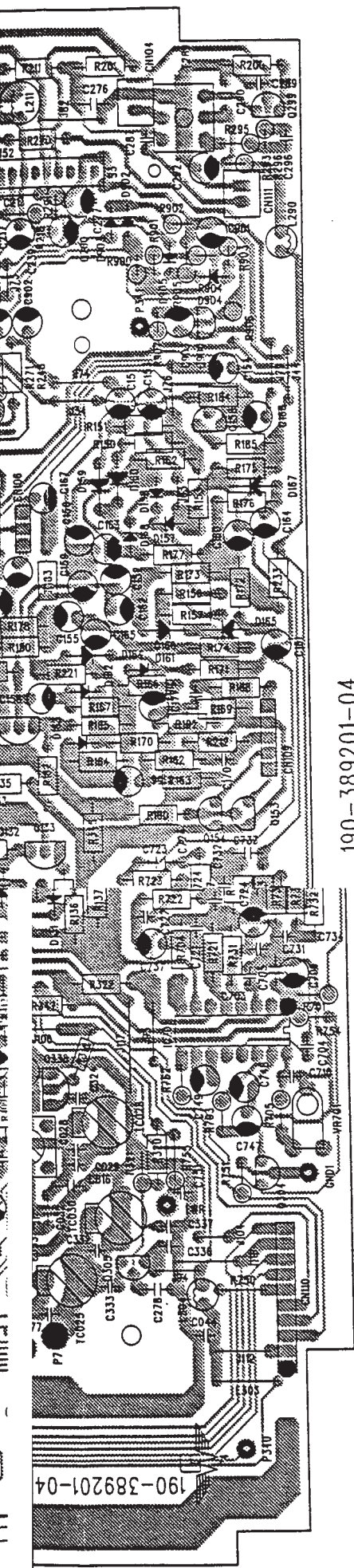

190-389201-04
MAIN PCB (FOR A,B,C)

30-389204-00
1-ADPHONE BOARD

190-389205-00
SPEAKER BOARD

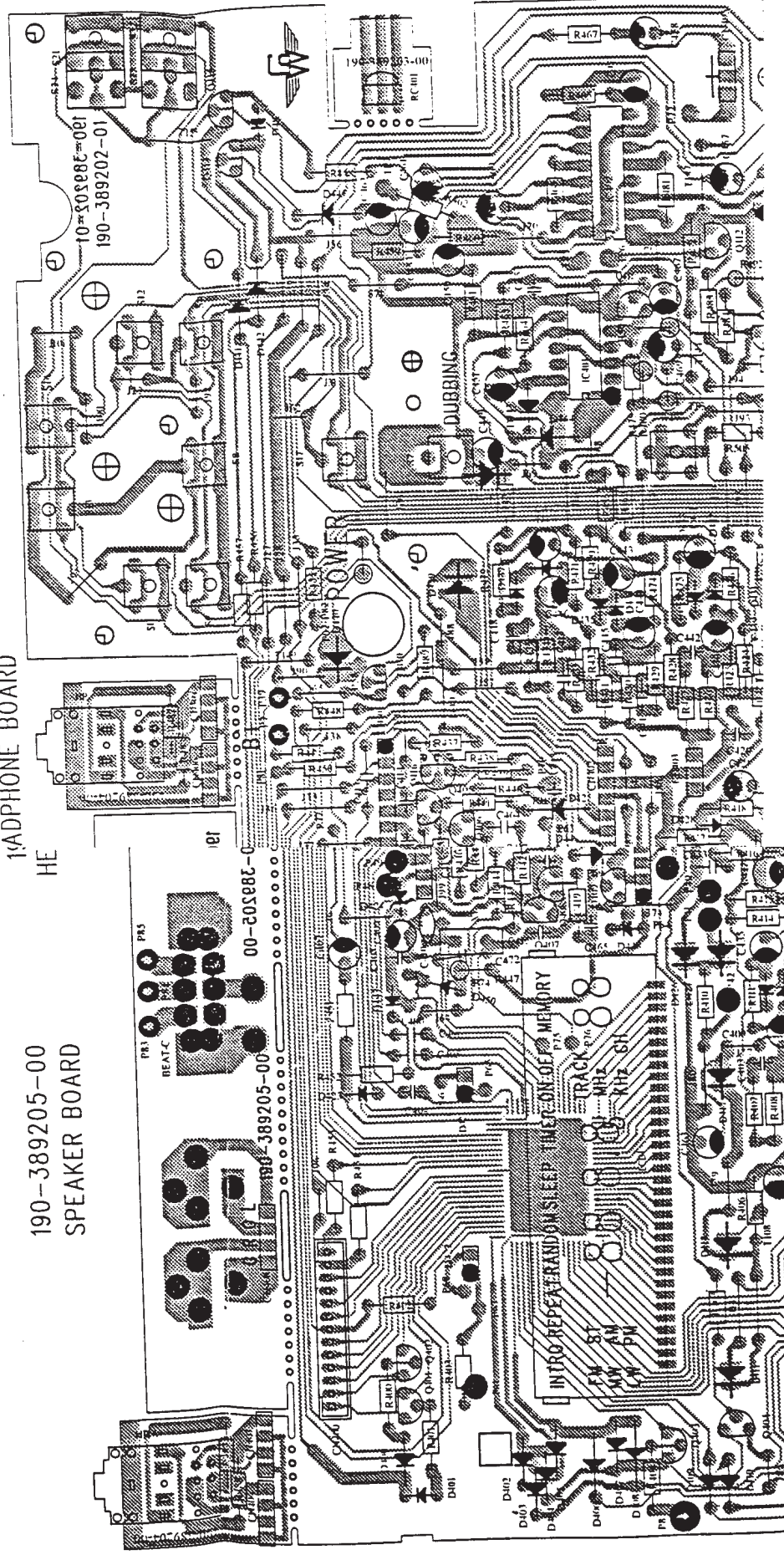

REMOTE
SENSOR
BOARD

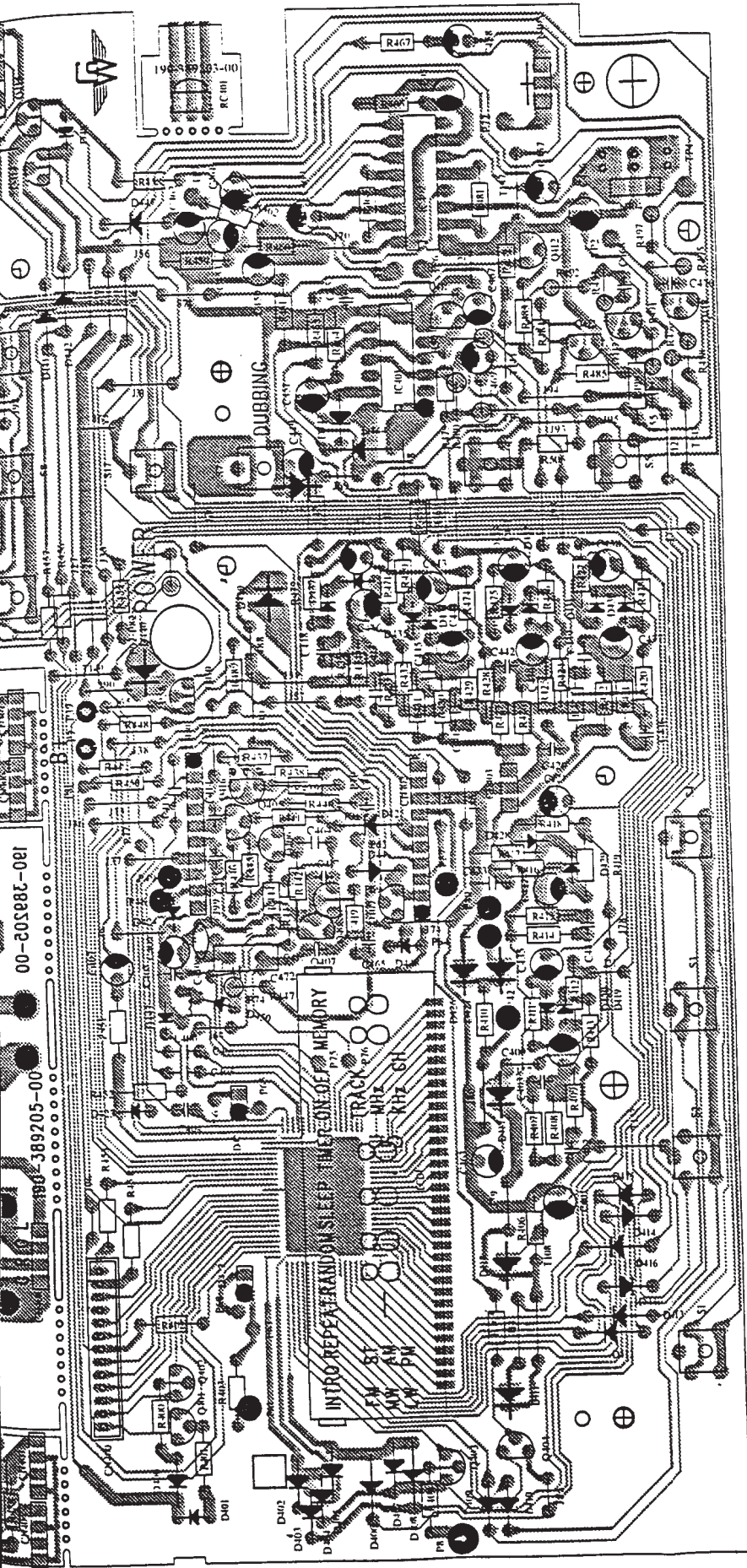

190-389202-01
DISPLAY PLL BOARD

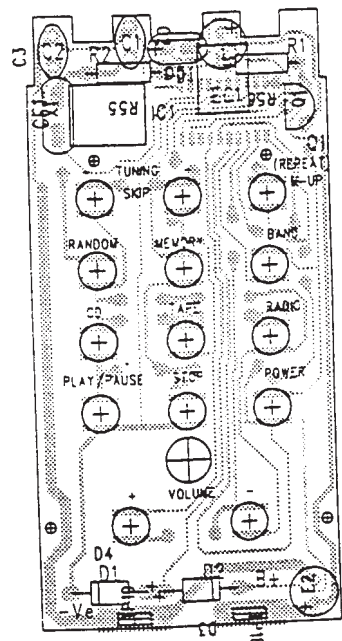

190-RC9301-00
REMOTE HANDSET BOARD

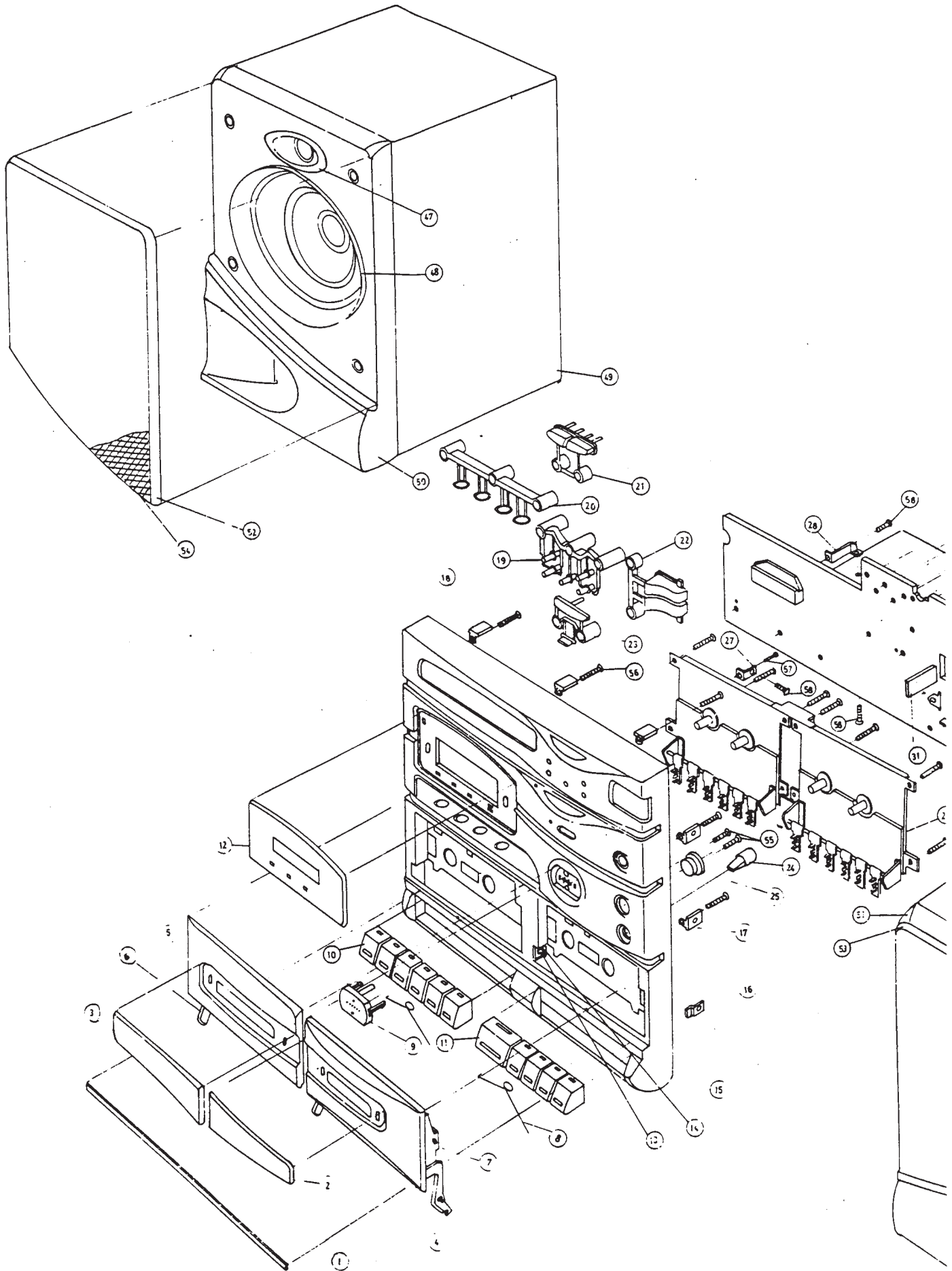

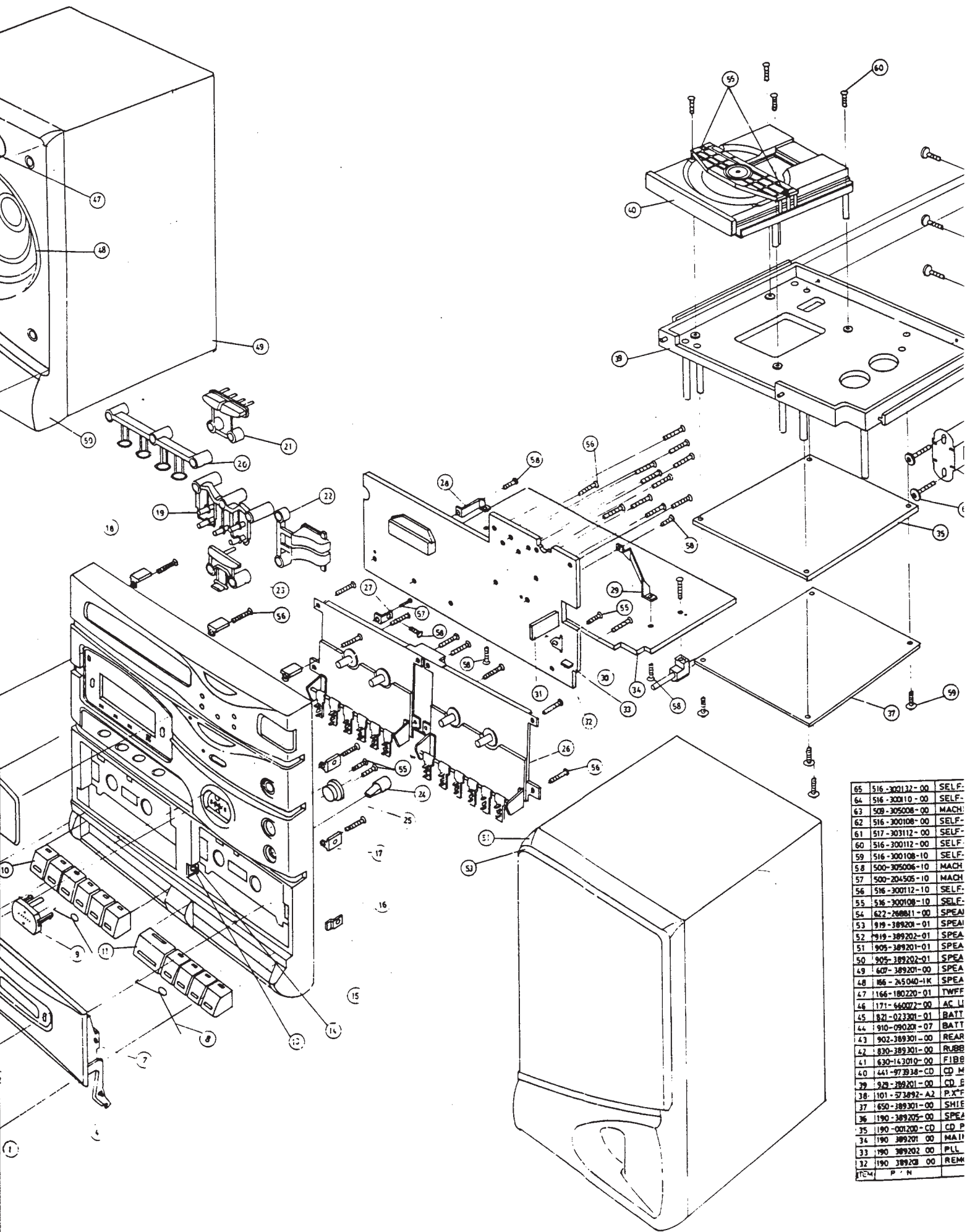

65	516-300132-00	SELF
64	516-30010-00	SELF
63	509-305008-00	MACH
62	516-300108-00	SELF
61	517-303112-00	SELF
60	516-300112-00	SELF
59	516-300108-10	SELF
58	500-305006-10	MACH
57	500-204505-10	MACH
56	516-300112-10	SELF
55	516-300108-10	SELF
54	622-268811-00	SPEAK
53	919-389201-01	SPEAK
52	919-389202-01	SPEAK
51	905-389201-01	SPEAK
50	905-389202-01	SPEAK
49	607-389201-00	SPEAK
48	866-265040-1K	SPEAK
47	166-180220-01	TWIFF
46	171-660072-00	AC LI
45	821-023301-01	BATT
44	910-090207-07	BATT
43	902-389301-00	REAR
42	830-389301-00	RUBB
41	630-163010-00	FIBER
40	441-973938-CD	CD M
39	929-389201-00	CD B
38	101-573892-A2	P.X.F
37	650-389301-00	SHIE
36	190-389205-00	SPEAK
35	190-001200-CD	CD P
34	190-389201-00	MATI
33	190-389202-00	PLL
32	190-389203-00	REM
ITEM	P.N	

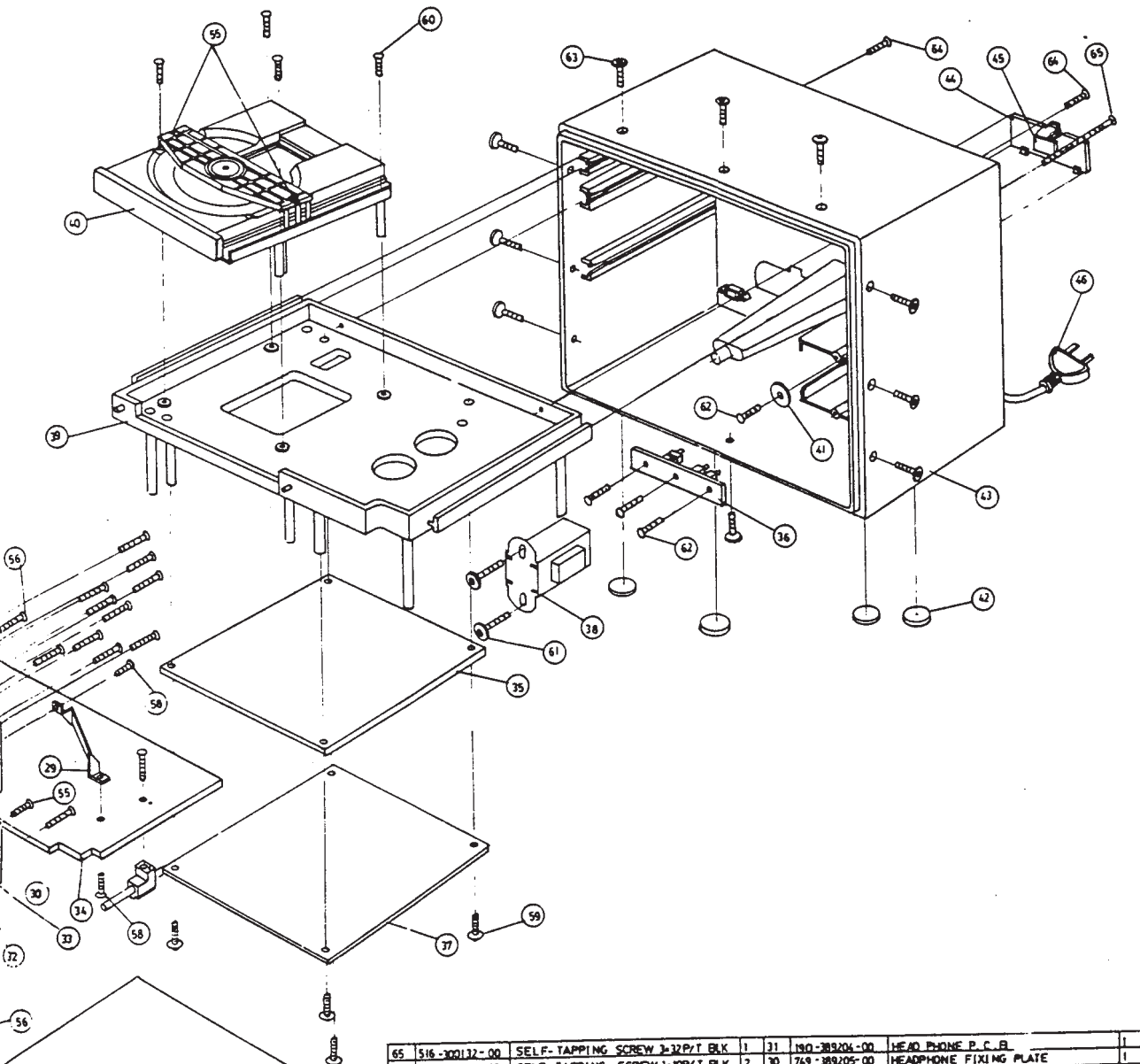

65	516-300132-00	SELF-TAPPING SCREW 3x12 P/T BLK	1	31	190-389204-00	HEAD PHONE P.C.B.	1
64	516-300110-00	SELF-TAPPING SCREW 3x10P/T BLK	2	30	749-389205-00	HEADPHONE FIXING PLATE	1
63	509-305008-00	MACHINE SCREW 3x6 K/M BLK	30	29	758-389202-00	PCB BRACKET	1
62	516-300108-00	SELF-TAPPING SCREW 3x8 P/T BLK	4	28	758-389201-00	PCB BRACKET	1
61	517-303112-00	SELF-TAPPING SCREW 3x12W/T	2	27	758-088802-00	RECORD PIN HOLDER	1
60	516-300112-00	SELF-TAPPING SCREW 3x12P/T BLK	4	26	441-217208-0A	DECK MECHANISM	1
59	516-300108-10	SELF-TAPPING SCREW 3x8 P/T	4	25	960-389205-01	REMOTE SENSOR LENS	1
58	500-204506-10	MACHINE SCREW 3x6 P/M	5	24	968-389207-00	BALANCE KNOB	1
57	500-204505-10	MACHINE SCREW 3x5P/M	1	23	958-389201-00	FUNCTION KNOB	1
56	516-300112-10	SELF-TAPPING SCREW 3x12 P/T	27	22	958-389202-01	CD OPEN/CLOSE KNOB	1
55	516-300108-10	SELF-TAPPING SCREW 3x8 P/T	5	21	958-389203-00	FUNCTION KNOB	1
54	622-268811-00	SPEAKER FRONT CAB HOLE FELT	2	20	958-389204-00	FUNCTION KNOB	1
53	918-389201-01	SPEAKER COVER (R)	1	19	958-389205-00	FUNCTION KNOB	1
52	919-389202-01	SPEAKER COVER (L)	1	18	749-389201-00	FIXING PLATE	3
51	905-389201-01	SPEAKER FRONT CAB (R)	1	17	749-389200-00	FIXING PLATE	4
50	905-389202-01	SPEAKER FRONT CAB (L)	1	16	749-389204-00	FIXING PLATE	2
49	607-389201-00	SPEAKER BOX (WOODEN)	2	15	900-389201-01	FRONT CAB	1
48	166-2x5040-1K	SPEAKER 4" x 4 OHM 5-7W	2	14	989-389201-00	GEAR HOLDER	1
47	1166-180220-01	TWFFTER SPEAK 2" 8OHM 0.2W	2	13	988-013801-00	GEAR	2
46	171-660072-00	AC LINE CORD	1	12	960-389201-01	DISPLAY LENS	1
45	821-023301-01	BATTERY SPONGE	1	11	972-389201-00	CASS KNOB	1
44	910-090201-07	BATTERY DOOR	1	10	972-628311-00	CASSETTE KNOB	10
43	902-389301-00	REAR CAB	1	9	973-389201-00	VOLUME KNOB	1
42	830-389301-00	RUBBER FOOT #15x4MM	4	8	771-389201-00	CASS DOOR SPRING	2
41	630-143010-00	FIBBER WASHER OD=14 ID=3 T=1 MM	1	7	911-389201-00	CASS DOOR BRACKET (R)	1
40	441-973938-CD	CD MECHANISM	1	6	911-389202-00	CASS DOOR BRACKET (L)	1
39	929-389201-00	CD BRACKET	1	5	911-389204-01	CASS DOOR (B/L)	1
38	101-373892-A2	PLYFORMER E157 230V	1	4	911-389203-01	CASS DOOR (A/R)	1
37	650-389301-00	SHIED PAPER 160x175x0.3MM	1	3	961-389203-01	CASS LENS (B/L)	1
36	190-389205-00	SPEAKER PCB	1	2	961-389202-01	CASS LENS (A/R)	1
35	190-001200-CD	CD PCB	1	1	960-389204-01	CASS KEY LENS	1
34	190-389201-00	MAIN PCB FOR 3892	1	1TB4	P / N	DESCRIPTION	QTY
33	190-389202-00	P/L PCB	1				
32	190-389203-00	REMOTE PCB	1				
ITEM	P / N	DESCRIPTION	QTY				

389201-00
 389202-00
 389203-00
 389204-00
 389205-00
 389206-00
 389207-00
 389208-00
 389209-00
 389210-00
 389211-00
 389212-00
 389213-00
 389214-00
 389215-00
 389216-00
 389217-00
 389218-00
 389219-00
 389220-00
 389221-00
 389222-00
 389223-00
 389224-00
 389225-00
 389226-00
 389227-00
 389228-00
 389229-00
 389230-00
 389231-00
 389232-00
 389233-00
 389234-00
 389235-00
 389236-00
 389237-00
 389238-00
 389239-00
 389240-00
 389241-00
 389242-00
 389243-00
 389244-00
 389245-00
 389246-00
 389247-00
 389248-00
 389249-00
 389250-00
 389251-00
 389252-00
 389253-00
 389254-00
 389255-00
 389256-00
 389257-00
 389258-00
 389259-00
 389260-00
 389261-00
 389262-00
 389263-00
 389264-00
 389265-00
 389266-00
 389267-00
 389268-00
 389269-00
 389270-00
 389271-00
 389272-00
 389273-00
 389274-00
 389275-00
 389276-00
 389277-00
 389278-00
 389279-00
 389280-00
 389281-00
 389282-00
 389283-00
 389284-00
 389285-00
 389286-00
 389287-00
 389288-00
 389289-00
 389290-00
 389291-00
 389292-00
 389293-00
 389294-00
 389295-00
 389296-00
 389297-00
 389298-00
 389299-00
 389300-00

SPARE PARTS LIST

THIS SPARE LIST IS MADE FOR TECHNICAL / MAINTENANCE REFERENCE ONLY

Assembly Number	Description
158-389201-01-00	NON-COMMON PART CHASSIS ASS'Y (A/F/L)
158-3892A4-00-FA	COMMON PART FOR CHASSIS ASS'Y (FORM A)
159-3892A0-00-00	COMMON PART FOR CASING ASS'Y (CD)
159-389209-01-00	NON-COM PART FOR CASING ASS'Y
162-009302-15-FA	REMOTE HANDSET ASS'Y FOR (GOODMANS)
162-389201-01-00	SPEAKER BOX ASS'Y (PCB-12)
162-3892A0-00-00	CD DRIVER ASS'Y (PCB-12)
183-389209-01-00	NON-COM PART FOR PACKING ASS'Y

Component Part	Description / Location	Unit	Subs	Quantity Required
ASSEMBLY	158-389201-01-00 NON-COMMON PART CHASSIS ASS'Y (A/F/L)			
103-116025-12	LQ COIL 160:25T 4 X 120MM (BEE COMB TYPE) M1	PC	0	1
105-393101-03	FIXED INDUCTIVE COIL (KONI) 39MM 10% L304, 003	PC	0	2
107-300450-06	AM CERAMIC FILTER 450KHZ (SFU 450B)	PC	0	1
107-310700-26	CERAMIC FILTER SFE10.7MA5 10.7MHZ BW=280KHZ RED DOT (MURATA)	PC	0	1
113-103105-12	CARBON FILM RESISTOR 10K OHM 1/4W +-5% R316,320,321,755	PC	0	4
113-223105-12	CARBON FILM RESISTOR 22K OHM 1/4W +-5% R317,318	PC	0	2
122-300100-01	TRIMMER CAPACITOR 30 PF TC028,030	PC	0	2
123-101350-10	CERAMIC CAP 100 PF 50V +-10% C332	PC	0	1
123-104370-30	CERAMIC CAP 0.1MFD 50V +80-20% C333,P327,324	PC	0	3
123-203370-30	CERAMIC CAP 0.02 MFD 50V +80-20% C044,336,337,751,278,311	PC	0	6
123-331350-10	CERAMIC CAP 330 PF 50V +-10% C028	PC	0	1
123-560350-10	CERAMIC CAP 56 PF 50V +-10% C029	PC	0	1
127-107038-01	ELECT. CAP 100 MFD +60-20% C045	PC	0	1
130-134148-00	SILICON DIODE IN4146 D003,004	PC	0	2
131-239014-03	TRANSISTOR 2SC9014C (HITACHI) NPN AF. C303,338	PC	0	2
183-220100-02	FERRITE BAR Q2M 10 X 100MM	PC	0	1

Component Part	Description / Location	Unit	Subs	Quantity Required
ASSEMBLY	158-3892A4-00-FA COMMON PART FOR CHASSIS ASS'Y (FORM A)			
012-102321-06	SEMI-FIXED RESISTOR B-1K OMM VR130	PC	0	1
012-103321-06	SEMI-FIXED RESISTOR 8-10K OHM H TYPE 3 PINS VR701	PC	0	1
102-110055-01	AM IFT AHC-55RO YELLOW T101,103	PC	0	2
102-210056-01	FM IFT PINK FHC-56RO T102	PC	0	1
102-210059-01	FM IFT ORANGE FHC-59RO T001	PC	0	1
102-810060-01	MW OSC COIL RED AM-0-060AM T002	PC	0	1
102-816000-01	REC OSC COIL BLACK AHO-019R P:0.6+0.5 5:4.1+2.4 OHM KONI T289	PC	0	1
103-206015-12	AM ANT. COIL 60:15T 4 X 120MM M1	PC	0	1
105-220156-03	FIXED INDUCTIVE COIL (KONI) 220M 15% L290,400	PC	0	2
105-393101-03	FIXED INDUCTIVE COIL (KONI) 39MH 10% L211,221,003,304	PC	0	4
107-476108-09	BAND BASS FILTER WB076-108 CF001	PC	0	1
111-503210-10	ROTARY VOLUME 50KB SINGLE L=150=17MM W/CENTRE CLICK BALANCE	PC	0	1
113-100105-12	CARBON FILM RESISTOR 10 OHM 1/4W +-5% R003	PC	0	1
113-101105-12	CARBON FILM RESISTOR 100 OHM 1/4W +-5% R008,440,444,462,701	PC	0	5
113-102105-12	CARBON FILM RESISTOR 1K OHM 1/4W +-5% R103,105,217,347,449,703	PC	0	6
113-102105-12	CARBON FILM RESISTOR 1K OHM 1/4W +-5% R752,757	PC	0	2
113-102105-17	CARBON FILM RESISTOR 1K OHM 1/4W +-5% R158,223,281,187,139,345,452,450,451,455	PC	0	11
113-103105-12	CARBON FILM RESISTOR 10K OHM 1/4W +-5% R408,419,426,430,441,446,456-7,463-4,751,740,RD445	PC	0	13
113-103105-12	CARBON FILM RESISTOR 10K OHM 1/4W +-5% R030,102,106,154,193,222,258,294,320,316,344,405	PC	0	12
113-103105-12	CARBON FILM RESISTOR 10K OHM 1/4W +-5% R321,755,756	PC	0	3
113-104105-12	CARBON FILM RESISTOR 100K OHM 1/4W +-5% R002,005,026,315,505	PC	0	5
113-120405-75	METAL OXIDE FILM RESISTOR 12 OHM 2W +-5% R100	PC	0	1
113-122105-12	CARBON FILM RESISTOR 1.2K OHM 1/4W +-5% R436	PC	0	1
113-123105-12	CARBON FILM RESISTOR 12K OHM 1/4W +-5% R170,247,417,428,432	PC	0	5
113-123105-12	CARBON FILM RESISTOR 12K OHM 1/4W +-5% R212,424	PC	0	2
113-124105-12	CARBON FILM RESISTOR 120K OHM 1/4W +-5%	PC	0	1
113-151105-12	CARBON FILM RESISTOR 150 OHM 1/4W +-5% R447	PC	0	1
113-152105-12	CARBON FILM RESISTOR 1.5K OHM 1/4W +-5% J89	PC	0	1
113-153105-12	CARBON FILM RESISTOR 15K OHM 1/4W +-5% R001,423,192,INPUT OF EACH CD *C158,159)	PC	0	5
113-154105-12	CARBON FILM RESISTOR 150K OHM 1/4W +-5% R006	PC	0	1
113-181105-17	CARBON FILM RESISTOR 180 OHM 1/4W +-5% R185,182	PC	0	2
113-182105-12	CARBON FILM RESISTOR 1.8K OHM 1/4W +-5% R480,490	PC	0	2
113-183105-12	CARBON FILM RESISTOR 18K OHM 1/4W +-5% R209,750,751	PC	0	3

Component Part	Description / Location	Unit	Subs	Quantity Required
113-204105-12	CARBON FILM RESISTOR 200K OHM 1/4W +-5% R255,742,744,746	PC	0	4
113-221105-12	CARBON FILM RESISTOR 200 OHM 1/4W +-5% R487,486	PC	0	2
113-222105-12	CARBON FILM RESISTOR 2.2K OHM 1/4W +-5% R139-40,292,322	PC	0	4
113-222105-12	CARBON FILM RESISTOR 2.2K OHM 1/4W +-5% R186,189,324,738,134	PC	0	5
113-222105-12	CARBON FILM RESISTOR 2.2K OHM 1/4W +-5% R409,429,481,465,186,324,322,292,734,RC140,141	PC	0	12
113-220105-12	CARBON FILM RESISTOR 2.2K OHM 1/4W +-5% R194,724	PC	0	2
113-223105-12	CARBON FILM RESISTOR 22K OHM 1/4W +-5% R317,318,443	PC	0	3
113-331105-12	CARBON FILM RESISTOR 330 OHM 1/4W +-5% R010	PC	0	1
113-332105-12	CARBON FILM RESISTOR 3.3K OHM 1/4W +-5% R192,212,338,204	PC	0	4
113-332105-17	CARBON FILM RESISTOR 3.3K OHM 1/4W +-5% R029,214,721,731,407,431	PC	0	6
113-333105-12	CARBON FILM RESISTOR 33K OHM 1/4W +-5% R123,124	PC	0	2
113-391105-12	CARBON FILM RESISTOR 390 OHM 1/4W +-5% R749	PC	0	1
113-470105-12	CARBON FILM RESISTOR 47 OHM 1/4W +-5% R241,165,743	PC	0	3
113-471105-12	CARBON FILM RESISTOR 470 OHM 1/4W +-5% R486	PC	0	1
113-472105-12	CARBON FILM RESISTOR 4.7K OHM 1/4W +-5% R138,410,414,427,459,460,737	PC	0	7
113-472105-12	CARBON FILM RESISTOR 4.7K OHM 1/4W +-5% R754,209	PC	0	2
113-472105-17	CARBON FILM RESISTOR 4.7K OHM 1/4W +-5% R414,442,427,144,722-3,732-3,739	PC	0	9
113-473105-12	CARBON FILM RESISTOR 47K OHM 1/4W +-5% R150,153	PC	0	2
113-473105-12	CARBON FILM RESISTOR 47K OHM 1/4W +-5% R266,302,309,424,471,475,412	PC	0	7
113-474105-12	CARBON FILM RESISTOR 470K OHM 1/4W +-5%	PC	0	1
113-561105-12	CARBON FILM RESISTOR 560 OHM 1/4W +-5%	PC	0	3
113-562105-12	CARBON FILM RESISTOR 5.6K OHM 1/4W +-5% R007	PC	0	1
113-562105-12	CARBON FILM RESISTOR 5.6K OHM 1/4W +-5% R433,421,476,419	PC	0	4
113-682105-12	CARBON FILM RESISTOR 6.8K OHM 1/4W +-5% R075,208,248,257,705,163,169	PC	0	7
122-100100-01	TRIMMER CAPACITOR 10 PF TC025,029	PC	0	2
122-300100-01	TRIMMER CAPACITOR 30 PF TC028,030,410	PC	0	3
123-030350-10	CERAMIC CAP 3 PF 50V +-10% C009	PC	0	1
123-080350-10	CERAMIC CAP 8 PF 50V +-10% C077	PC	0	1
123-101350-10	CERAMIC CAP 100 PF 50V +-10% C012,332,008	PC	0	3
123-102370-30	CERAMIC CAP0.001 MFD 50V +80-20% C006,102,126,127,404-6	PC	0	7
123-103370-30	CERAMIC CAP0.01 MFD 50V +80-20% C2,020,010-1,030,130,133-4,267,304,415,418,452,465	PC	0	14
123-151350-10	CERAMIC CAP 150 PF 50V +-10% C001	PC	0	1
123-201350-10	CERAMIC CAP 200 PF 50V +-10% C201,251	PC	0	2
123-203370-30	CERAMIC CAP 0.02MFD 50V +80-20% C030,035,044,098,100-3,278,290,303,306,311A,705	PC	0	14

Component Part	Description / Location	Unit	Subs	Quantity Required
123-203370-30	CERAMIC CAP 0.02MFD 50V +80-20% C311	PC	0	1
123-203370-30	CERAMIC CAP 0.02MFD 50V +80-20% C907,CR341	PC	0	2
123-300350-10	CERAMIC CAP 30 PF 50V +-10% C023	PC	0	1
123-301350-10	CERAMIC CAP 300 PF 50V +-10% C253,254	PC	0	2
123-330350-10	CERAMIC CAP 33 PF 50V +-10% C007,516	PC	0	2
123-391350-10	CERAMIC CAP 390 PF 50V +-10% C005	PC	0	1
123-403370-30	CERAMIC CAP 0.04 MFD 50V +80-20% C515,704	PC	0	2
123-501350-10	CERAMIC CAP 500 PF 50V +-10%	PC	0	1
123-560350-10	CERAMIC CAP 56 PF 50V +-10% C30J	PC	0	3
125-102070-02	POLY. CAP. 1000 PF 50V +-5% C710	PC	0	1
125-471010-02	POLY. CAP. 470 PF 50V +-5% C032	PC	0	1
126-102071-01	MYLAR CAP. 0.001 MFD 50V +-10% C722,723,732,733,439,448,287	PC	0	7
126-103071-01	MYLAR CAP. 0.01 MFD 50V +-10% C434,442,721,731	PC	0	4
126-104071-01	MYLAR CAP. 0.1 MFD 50V +-10% C115,118,124,433,420,464	PC	0	6
126-203071-01	MYLAR CAP. 0.02 MFD 50V +-10% C218	PC	0	1
126-222071-01	MYLAR CAP. 0.0022 MFD 50V +-10% C203,204,212,213,232,242,289,290,296,417	PC	0	10
126-223071-01	MYLAR CAP. 0.022 MFD 50V +-10% C201,202	PC	0	2
126-332071-01	MYLAR CAP. 0.0033 MFD 50V +-10% C289	PC	0	1
126-472071-01	MYLAR CAP. 0.0047 MFD 50V +-10% C276,403,445	PC	0	3
126-823071-01	MYLAR CAP. 0.0082 MFD 50V +-10% C402,411	PC	0	2
127-104078-01	ELECT. CAP. 0.1 MFD 50V +80-20% C298,299	PC	0	2
127-105078-01	ELECT. CAP. 1 MFD 50V +80-20% C748,749,262,273,274,906	PC	0	6
127-107038-01	ELECT. CAP. 100 MFD 10V +80-20% C014,125,128,129,141,401,463,453,467	PC	0	9
127-107048-01	ELECT. CAP. 100 MFD 16V +80-20% C125	PC	0	1
127-225078-01	ELECT. CAP. 2.2 MFD 50V +80-20% C421-2,435,437,438,440,441,443,444,446,447,462,466	PC	0	13
127-225078-01	ELECT. CAP. 0.1 MFD 50V +80-20% C150-3,156-9,161-4,221,239,248-9,260-1,281-2,400	PC	0	20
127-227038-01	ELECT. CAP. 220MFD 10V +80-20% C107,154,155,160,165,292,407,409,449,450,706	PC	0	11
127-227048-01	ELECT. CAP. 220 MFD 16V +80-20% C266,307,458	PC	0	3
127-474078-01	ELECT. CAP. 0.47 MFD 50V +80-20% C747	PC	0	1
127-475048-01	ELECT. CAP. 4.7 MFD 16V +80-20%	PC	0	5
127-475078-01	ELECT. CAP. 4.7 MFD 50V +80-20% C127,140,169,239,260,312,456-7,459-61,727,737	PC	0	13
127-475078-01	ELECT. CAP. 4.7 MFD 50V +80-20% C755,451	PC	0	2
127-476038-01	ELECT. CAP. 47 MFD 10V +80-20% C168,206,216,220,236,246,305,460,452	PC	0	9
130-134148-00	SILICON DIODE IN4148 D001-4,130-4,154,157-68,171-3,175-6,450,412-3,416	PC	0	31

Component Part	Description / Location	Unit	Subs	Quantity Required
130-134148-00	SILICON DIODE IN4148 D48,400-1,403-4,407,409-10,414-15,419-20,446	PC	0	13
130-134148-00	SILICON DIODE IN4148 D178,DR109	PC	0	2
130-230101-24	FM TUNING DIODE ISV101 VD001,002	PC	0	2
130-230149-14	AM TUNING DIODE ISV1498 VD025,026	PC	0	2
130-131001-00	RECTIFIER DIODE IN4001 50V/1A D448	PC	0	1
130-315401-00	RECTIFIER DIODE IN5401 100V/3A D100,101,102,103	PC	0	4
130-410051-00	ZENER DIODE 5.1V 1/2W ROHM MTZ J5.1B (4.94 TO 5.20) D169,424	PC	0	2
130-410095-00	ZENER DIODE 9.5V 1/2W ZD104	PC	0	21
130-510124-00	LED LAMP RED 3MM TLR124 (TOSHIBA/SANYO) D411,417,418	PC	0	2
131-232458-16	TRANSISTOR 2SC2458-GR NPN AF. (TOSHIBA) Q407,408	PC	0	2
131-240882-17	TRANSISTOR 2S0882Q (NEC) NPN 30C/3A Q100	PC	0	1
131-3CG855-0C	SI-PNP TR 3CG8550C (J88550C) -40V 1.5A TO-92 CHINA POSMAN Q101,102,150	PC	0	3
131-3CG901-5C	SI-PNP TR 3CG9015C (JE9015C) -30V 1A TO-92 CHINA POSMAN Q130,403,404,406,103	PC	0	5
131-3DG170-2L	TRANSISTOR 3DG1702L (ED1702L) Q299	PC	0	1
131-3DG901-4C	SI-PNP TR 3DG9014C (JE9014C) 30V .1A TO-92 CHINA POSMAN Q002,131-3,155,158,267,300-5,410,411,414-6,418,901	PC	0	20
133-001332-18	I.C. BA1332 (ROHM) MPX DECODER IC701	PC	0	0
133-004013-14	I.C. TC4013 CMOS TOSHIBA IC401	PC	0	1
133-0091153-14	I.C. TC 9153AP IC402	PC	0	1
133-102281-61	I.C. KA2261 MPX DECODER SAMSUNG IC701	PC	0	0
133-103381-16	I.C. LA3361 (SANYO) MPX DECODER IC701	PC	0	1
133-107358-14	I.C. TA 7358AP (TOSHIBA) FM RF PRE-AMP + MIXER IC001	PC	0	1
133-107757-14	I.C. TA 7757 TOSHIBA AM/FM IF. IC101	PC	0	1
133-207135-11	POWER IC AN7135 (DUAL)	PC	0	1
133-208142-14	QUARD PRE-AMP IC TA8142 W/ALC TOSHIBA IC201	PC	0	1
133-930906-14	IC TC9309-106 (CDP + DTS CONTROLLER) IC102	PC	0	0
135-939309-03	LCD DISPLAY FOR IC:TC9309 HOSIDEN MLC8423-012218	PC	0	1
136-500638-00	REMOTE RECEIVER DETECTING SENSOR # RPM-638CBR (R OHM) CN405	PC	0	1
137-720000-23	CRYSTAL 7.2 MHZ +-30PPM MC-49ULC:20PF (RICHWIDE:SEG),CQ.	PC	0	1
144-092017-05	PUSH SW. PS92D04 NS 9P2T (NON-SHORTING) RAINBOW	PC	0	1
145-02241E-06	SLIDE SW. 2P2T SS22F17G6 BLACK BEAT CUT	PC	0	1
147-110100-00	MICRO SW. MASUSHITA:EVQ-PBD04MHIGH 4.3 MM /MITSUMI SOH-211 HS S1-14,17,21,22	PC	0	3
161-123502-20	STEREO HEADPHONE JACK W/2P2T SWITCH TC38-020-05 (5+6 PINS)	PC	0	1
161-163503-20	EARPHONE SOCKET D:3.5MM H:11.5MM TAI CHUNG TC38-008	PC	0	2
441-217208-0A	DECK MECHANISM-12V MMI MOTOR AC BIAS R/P HEAD	PC	0	1
750-063101-00	SOLDERING LUG LEG:8X4MM 1- DECK GROUND	PC	0	1

