

AMSTRAD

2097

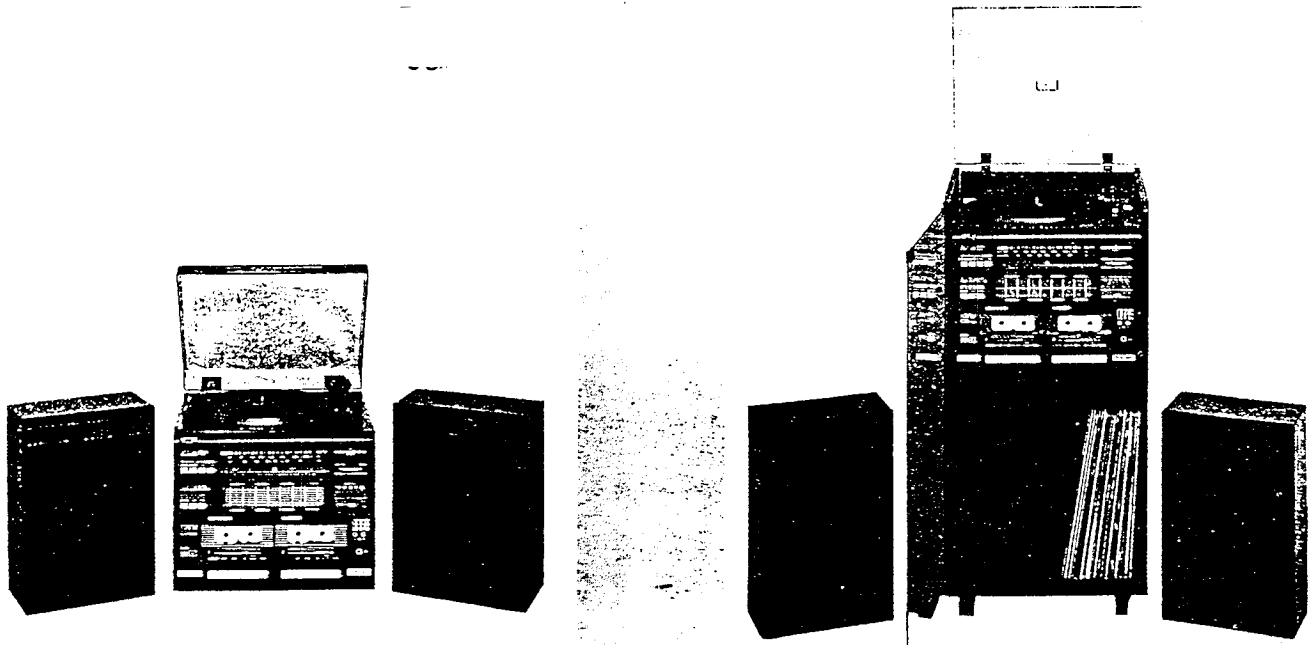

**MS-45/F
MIDI SYSTEM
TS46/F
TOWER SYSTEM
SERVICE MANUAL**

CONTENTS

	Page
Technical Specification	2
Safety Test	2
Alignment Instructions	3-6
Alignment Points	6
Troubleshooting Guide	7, 8
Record Deck & Parts List	9
Cassette Decks & Parts List	10 & 11
Circuit Diagram	12 & 13
TS46 Cabinet & Parts List	14
Function, Stereo LED, Standby LED P.C.B.s, Top & Bottom Views	15
Tuner P.C.B., Top & Bottom Views	16
Terminal Chassis, Deck & Power Supply P.C.B.s, Top & Bottom Views	17
Amp P.C.B., Top & Bottom Views	18
Rectifier & Bias & Level LED P.C.B.s, Top & Bottom Views	19
Volume P.C.B., Top & Bottom Views	20
Electrical Parts List	21
Wiring Diagram	23
Chassis Drawing & Parts List	24

TECHNICAL SPECIFICATION

AMPLIFIER SECTION

Power Output	: 2.5W/Channel @ 1% THD
	: 10 Watts Total @ 10% THD
Frequency Response	: 20Hz to 20,000Hz
Distortion	: 1% @ Full Power
Tone Controls	: Bass (20-200), Mid (200-2k) & Treble (2k-20k)Hz \pm 10dB

TUNER SECTION

FM Band Freq. Range	: 86.5 - 109MHz
AM Band Freq. Range	: 525 - 1650kHz
FM Sensitivity	: 3uV
FM Aerial Input	: 75 ohms unbalanced

CASSETTE SECTION

Tape	: Compact-Cassette Type
Tape Speed	: 4.75cm/sec
Tracks	: 4 Track, 2 Channel Stereo
Wow & Flutter	: 0.2%
Frequency Response	: 80Hz - 12kHz
Microphone Sensitivity	: 0.5mV @ 600 ohms

PHONO SECTION

Transmission	: Belt-Drive
Cartridge Type	: Ceramic
Turntable Control	: Manual with Auto-Stop
Speed Control	: Electronic

DIMENSIONS AND WEIGHTS MS45

Main Unit (mm)	: 360(w) x 320(h) x 330(d)
Weight	: 7.25Kgs
Speakers (mm)	: 180(w) x 260(h) x 140(d)
Weight	: 3.6Kgs each

DIMENSIONS AND WEIGHTS TS46

Main Unit (mm)	: 397(w) x 790(h) x 370(d)
Weight	: 21Kgs
Speakers (mm)	: 260(w) x 390(h) x 140(d)
Weight	: 4Kgs each

SUPPLY DETAILS

Voltage	: 240 Volts A.C. only
Frequency	: 50Hz only

SAFETY

All units are tested to the following safety specification during manufacture:-

- Flash Test:** Tested at 2.2kV between live and neutral of the mains lead joined together and all accessible metal points on the exterior of the set.
- Insulation resistance test:** Tested between the live and neutral of the mains lead joined together and all accessible metal points on the exterior of the set to show a resistance of at least 4Mohms at 500V DC.
- Earth lead continuity test:** Tested for a continuity of less than 0.5ohms at 10 Amps between the earth of the mains lead and the record deck transit screw.

If there are any doubts about continued electrical safety after servicing, the above tests should be carried out.

ALIGNMENT INSTRUCTIONS

Equipment Required:

- | | |
|--|-------------------------------|
| 1. AM signal generator | 6. Nonmetallic alignment tool |
| 2. FM signal generator | 7. AF oscillator |
| 3. IF sweep generator with marker capabilities | 8. Frequency counter |
| 4. Oscilloscope | 9. Distortion meter |
| 5. VTVM | |

Important:

1. Check line voltage.
2. Set function switch to band being aligned.
3. Set the loudness switch to off.
4. Remove the antenna from the terminal.
5. Set tone control to high.
6. Connect low side of signal source and output indicator to chassis ground (unless otherwise specified). Ground connection should be kept close to high side connection.
7. Signal input should be kept as low as possible to avoid AVC and AFC action. (Set output indicator to high sensitivity.)
8. Standard modulation is 1000Hz at 30% amplitude for AM (1000Hz at 22.5kHz deviation for FM).

AM IF

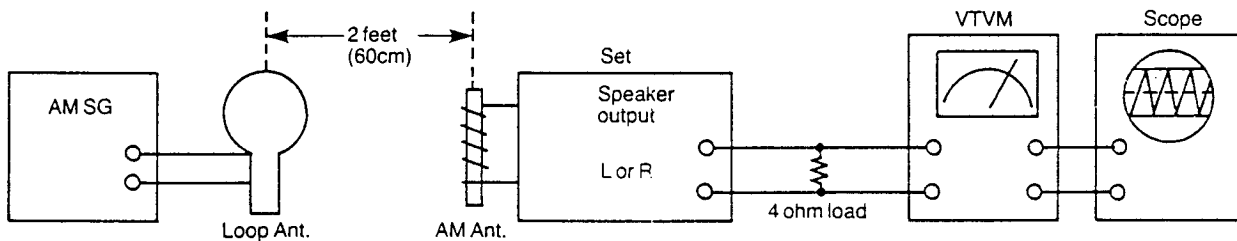

Figure 1

AM Section

Circuit Alignment	Equipment Connection	Step	Gen. Freq.	Dial Setting	Adjustments
IF	AM signal generator with loop antenna (See Fig. 1)	1	465 kHz (1000 Hz Mod.)	Tuning gang fully closed	T3 (AM IFT) Adjust for maximum output.
		2			Repeat until no further improvement can be made.

AM BAND/TRACKING

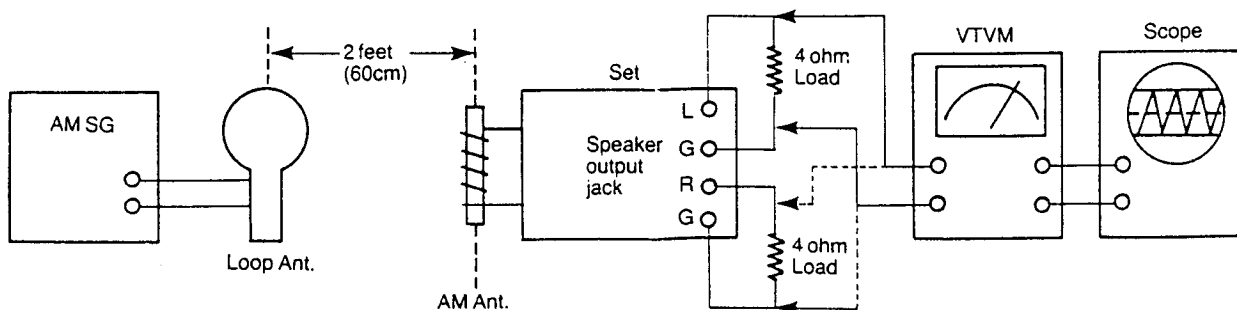

Figure 2

Circuit Alignment	Equipment Connection	Step	Gen. Freq.	Dial Setting	Adjustment
MW BAND	AM Signal Generator with loop antenna. VTVM across 4 ohm load. (See Fig. 2.)	1	520 kHz (1000 Hz Mod.)	Tuning gang fully closed	L5 (MW Osc. coil) Adjust for maximum output.
		2	1650 kHz (1000 Hz Mod.)	Tuning gang fully open	TC6 (MW Osc. trimmer) Adjust for maximum output.
		3			Repeat steps 1 and 2.
MW TRACKING	AM signal Generator with loop antenna. VTVM across 4 ohm load. (See Fig. 2.)	4	600 kHz (1000 Hz Mod.)	Tune to signal	L3 (MW Ant. coil) Adjust coil on ferrite core for maximum output.
		5	1000 kHz (1000 Hz Mod.)	Tune to signal	TC3 (MW Ant. trimmer) Adjust for maximum output.
		6			Repeat steps 4 and 5 several times.
LW	BAND		14.5-280 kHz		L7 TC5.
	TRACKING		160/250 kHz		L4 TC4.

FM IF

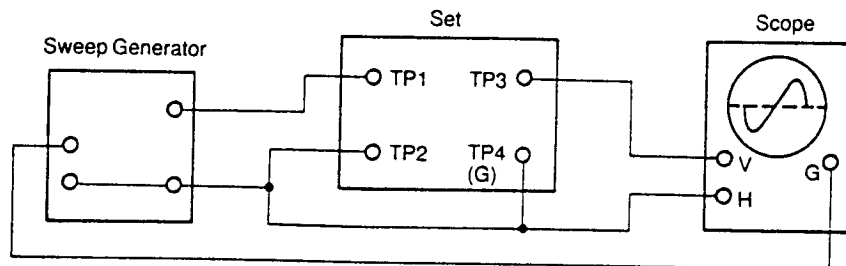

Figure 3

FM Section

Circuit Alignment	Equipment Connection	Step	Gen. Freq.	Dial Setting	Adjustment
IF	IF sweep Marker generator to FM Antenna Terminal TP1, TP2. Oscilloscope from "TP3 to TP4" (See Fig. 3.)	1	10.7 MHz	Tuning gang fully closed	T1, T2 (FM IFT) Adjust for maximum symmetrical response. (10.7 MHz at the center point)
		2			Repeat step 1.

FM BAND/TRACKING

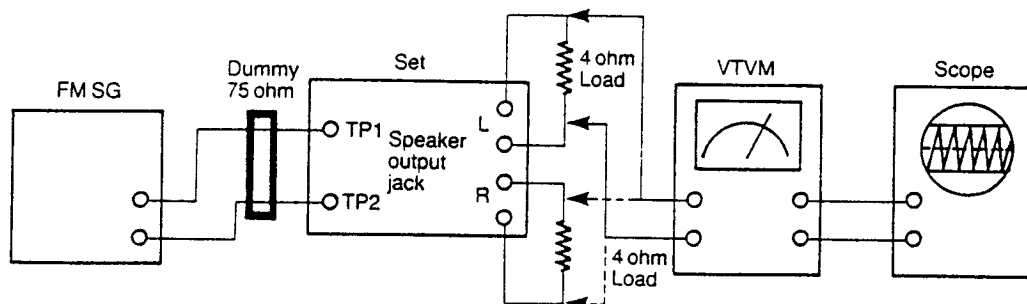

Figure 4

FM Section

Circuit Alignment	Equipment Connection	Step	Gen. Freq.	Dial Setting	Adjustments
LOCAL OSCILLATOR (BAND)	FM signal generator to antenna terminals (TP1, 2) through 75 ohm antenna matching network. VTVM across 4 ohm load. (Fig. 4)	1	87 MHz (Mod.)	Tuning gang fully closed	L2 (FM OSC. coil) - stretch or squeeze Adjust for maximum output.
		2	109 MHz (Mod.)	Tuning gang fully open	TC2 (FM OSC. Trimmer) Adjust for maximum output.
		3			Repeat steps 1 and 2 several times.
RF AMPLIFIER (TRACKING)	Same as "LOCAL OSC"	4	90 MHz (Mod.)	Tune to signal	L1 (FM RF coil) Adjust for maximum output - stretch or squeeze.
		5	106 MHz (Mod.)	Tune to signal	TC1 (FM RF Trimmer) Adjust for maximum output.
		6			Repeat steps 4 and 5 to obtain suitable sensitivity at 90 MHz and 106 MHz.

FM MPX

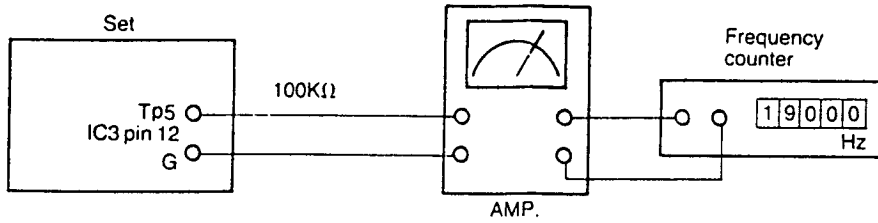

Figure 5

FM MPX

Circuit Alignment	Equipment Connection	Gen. Freq.	Dial Setting	Adjustments
19/38 kHz	Freq. Counter from TP5 to ground (Fig. 5)	98 MHz (Mod.)	98 MHz	First make sure FM section is properly aligned. Adjust R24 for frequency counter indication of 19 kHz.

TAPE SPEED/AZIMUTH

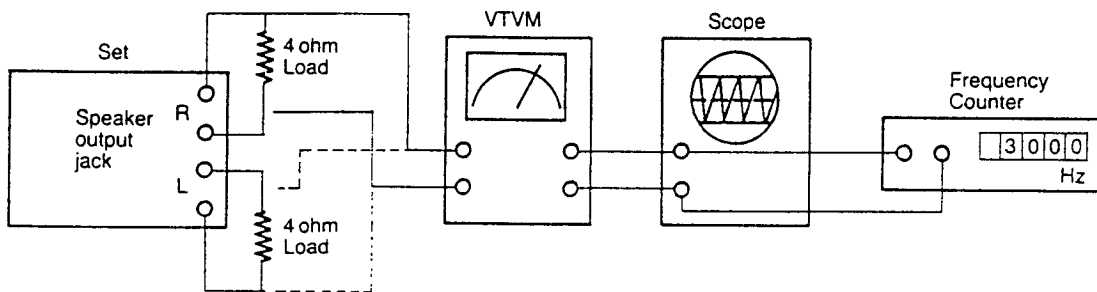

Figure 6

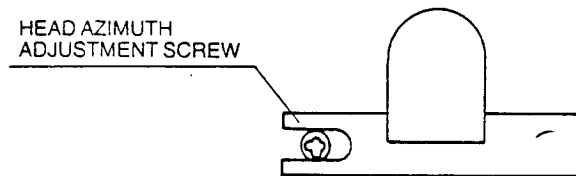

Figure 7

Alignment of tape speed

- Play a standard test tape recorded with 3 kHz signal (or 1 kHz). (Equipment connection: See Figure 6.)
- Adjust variable resistor in motor or Deck PCB R113 to provide 3 kHz (1 kHz) frequency.

Alignment of Had azimuth

- Play a standard test tape recorded with 8 kHz signal such as TEAC MTT-113CN. (See Fig. 6)
- Adjust the azimuth adjustment screw for maximum output. (See Fig. 7)

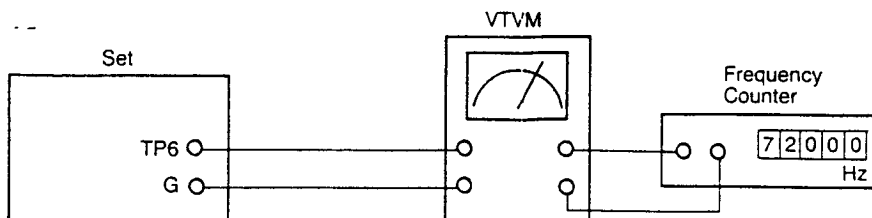

Figure 8

BIAS FREQUENCY

Alignment of recording bias OSC frequency.

- Connect frequency counter to VTVM OUTPUT, connect VTVM to TP6 and Ground. (See Figure 8.)
 - In record mode, record bias OSC frequency must be 72 kHz; adjust with L7, if necessary.
 - In record mode, record bias voltage must be $E3=510\mu A$; adjust with R117, if necessary.
- [See Figure 9] $E3=(E1+E2)/2$.

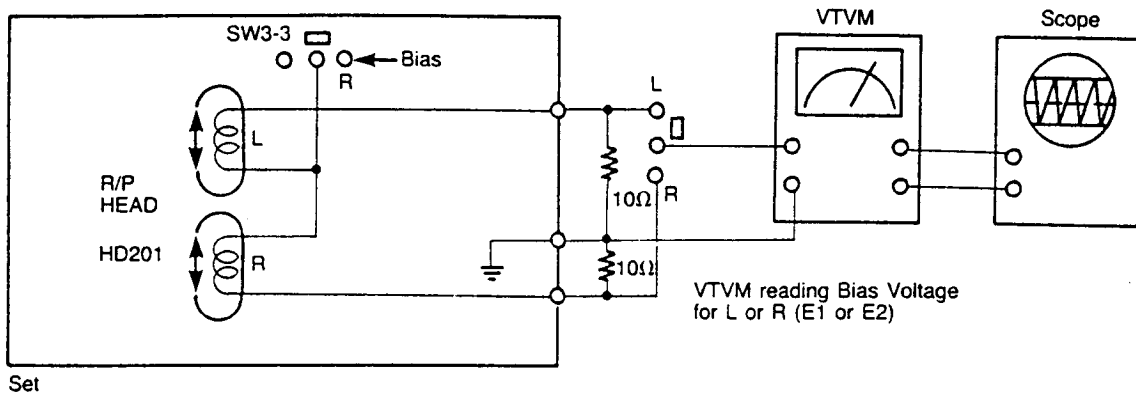
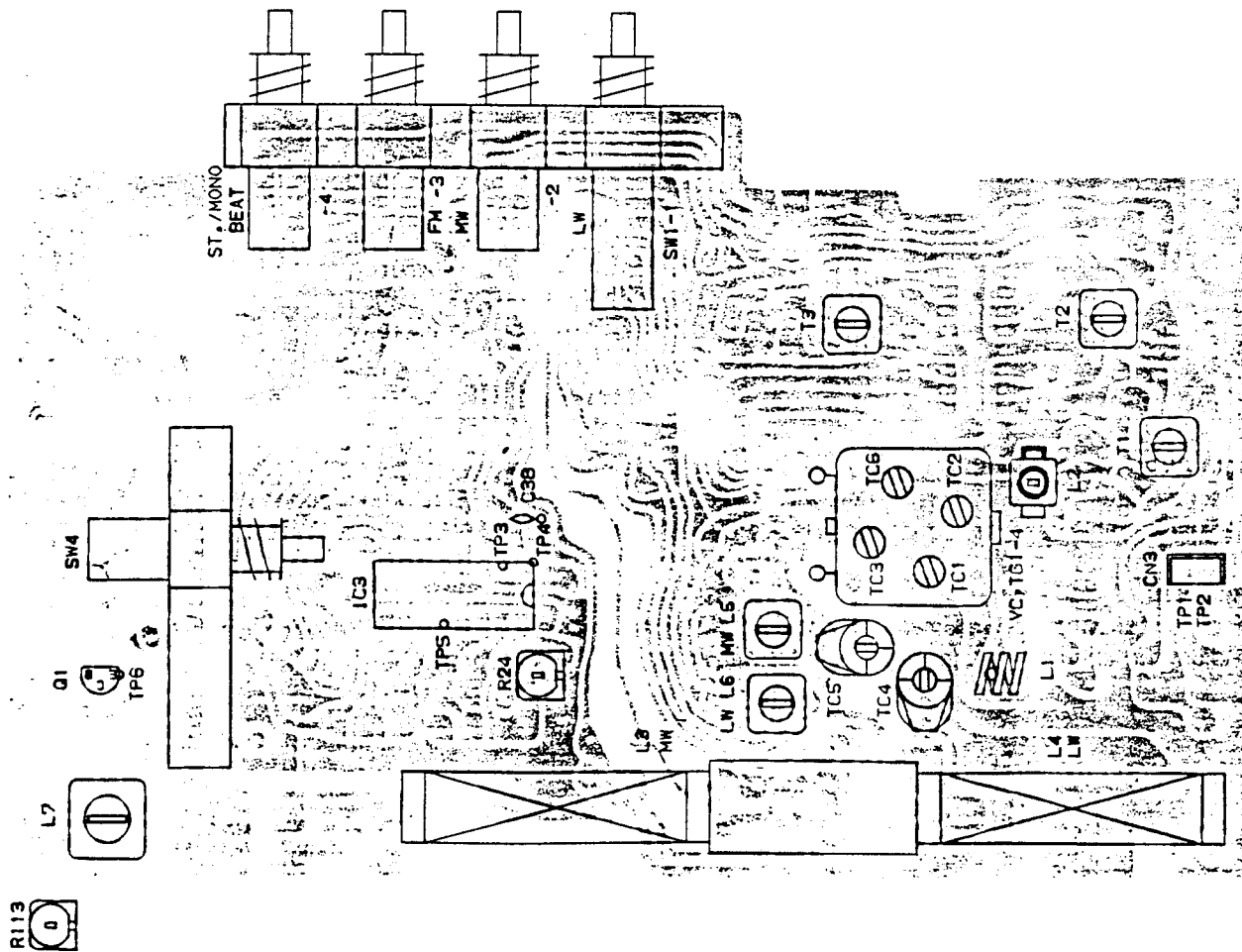

Figure 9

ALIGNMENT POINTS



TROUBLESHOOTING GUIDE

RECEIVER SECTION

CIRCUIT	SYMPTOM	CAUSE	REMEDY
GENERAL	Inoperative	Defective power switch (SW4)	Replace as necessary.
		Open circuit in transformer (T601)	Check current and voltages. Replaces as necessary.
		Defect in power supply circuit	Check current and voltages. Replace as necessary.
	No sound	Defective volume control	Check volume control resistance for continuous operation. Replace as necessary.
		Defective function switch (SW2)	Replace or repair switch.
AM	No sound	Defective detector	Check voltages in this circuit. Repair/Replace as necessary.
		Open circuit in AM IFT ANT	Check voltages and resistance.
		Coil or Osc. coil (T3, L4/MW, L5/LW)	Replace as necessary.
	Weak sound (low sensitivity)	IF misaligned	Re-adjust (See Alignment Instructions).
		RF misaligned	Re-adjust (See Alignment Instructions).
		Defective IC2	Check voltages. Replace as necessary.
		Poor contact in Antenna circuit	Resolder and/or repair. Replace as necessary.
		Defective Band switch (SW1)	Repair or replace switch.
	Defective in Detector	Check voltages.	
FM	No sound	Open circuit in FM IFT	Check voltages and resistances.
		Antenna coil or Osc. coil (L1, L2)	Replace as necessary.
	Weak sound (low sensitivity)	Defective FM tuner	Check RF, IF and Detector circuits. Check voltages of IC1 and IC2. Replace parts as necessary.
		RF misaligned	Re-adjust (See Aligment Instructions).
		Defective IC1, IC2	Check voltages and replace as necessary.
		Poor contact in FM Ant.	Resolder or replace as necessary.
		Defective IC3	Check voltages of IC3. Replace as necessary.
MPX	Poor separation	Improper adjustment of VC0	Re-adjust R24. (See Alignment Instructions).
	No stereo Indicator	Faulty D4	Check indicator D4 and circuit. Replace as necessary.

continued over.....

SYMPTOM		CIRCUIT	REMEDY
No sound	on both channels	Power supply	Check voltage of transformer of Q7. Replace as necessary.
	on Rch (Lch)	Motor	Check voltage at motor (9V). If not proper voltage, change motor.
		Pre-amplifier	Check voltage of IC5 (Pin 11, 15). Replace as necessary.
	on both Lch & Rch	Power supply	Check voltage of IC5 (Pin 2 or Pin 14). Replace as necessary.
Distortion	on Rch (Lch)	Pre-amplifier	Check voltage on pin 6 of IC5. Replace as necessary.
Poor high frequency	on Rch (Lch)	Tape head	Check head azimuth. Re-align as in the alignment instructions. Replace if there are scratches.
		Equalizer amplifier	Check voltage of IC5 (Pin 4 or Pin 12) Replace as necessary.
No erasing or no recording	on both Lch & Rch	Bias oscillator	Check erase head. (Open or defective.) Check erase head lead wires. Check Osc. output voltage. (72kHz 15V rms.) If not, replace Osc. coil L7 as necessary.
Defect in recording (no recording, weak recording or excessive recording level)	on Rch (Lch)	Record amplifier.	Check that rec-signal is supplied to R/P head. If not check mic Jack, R/P slide switch and IC4 voltage.
		Bias	Check bias current. If not, replace Osc. coil L7.

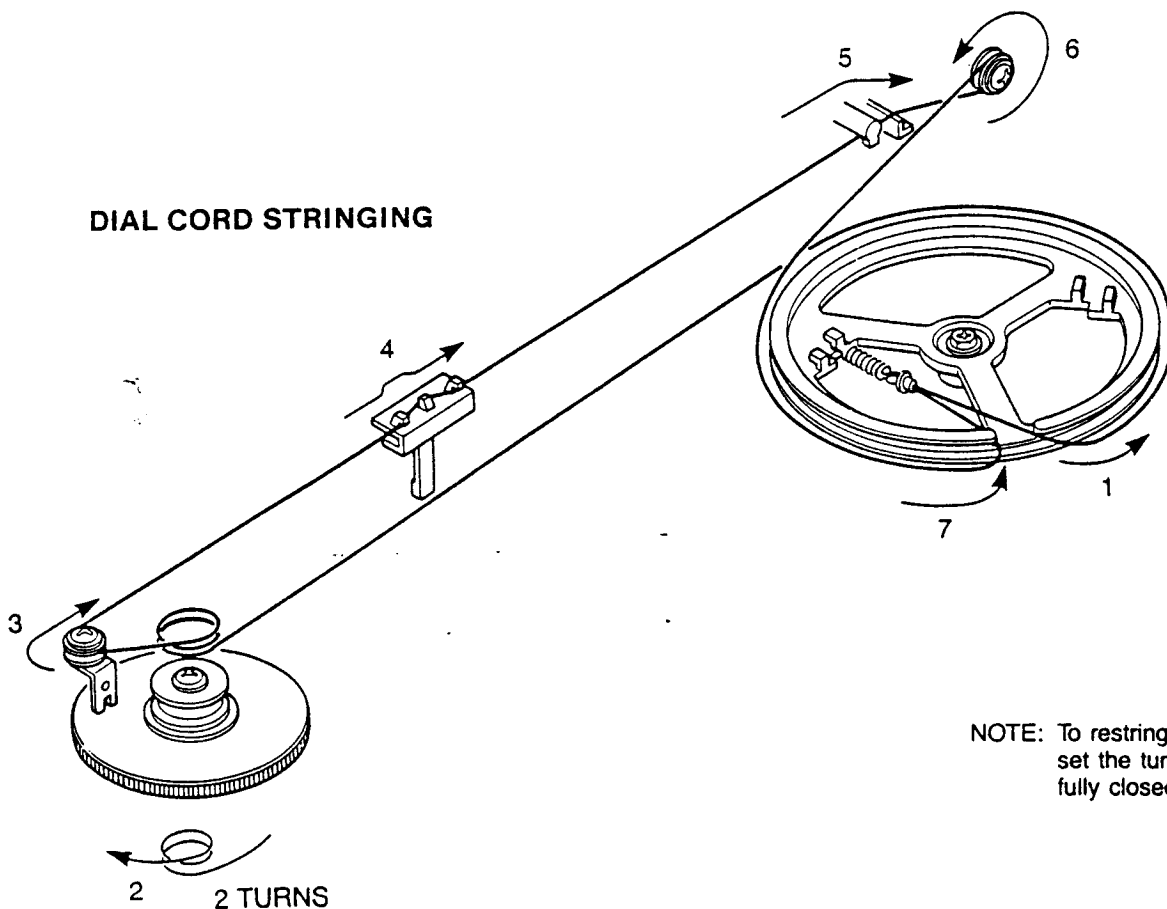

RECORD DECK PARTS LIST

No.	Description	Part No.
1	45 Adaptor	200103
2	E-Ring	200213
3	Turntable	200790
4	Belt	200122
5	Nylon Washer	
6	Spindle	200791
7	Push On Retainer	200841
8	Trip Pawl	200217
9	Clutch Plate	200218
10	Slider	200219
11	Catch	200842
12	Motor Base (Plinth)	200843
13	Cushion	200821
14	Lifter	200115
15	Lock	200229
16	Bracket Fixing	200844
17	Screw Motor	
18	Motor Pulley	200788
19	Motor 9V	200787
20	Plain Washer	
21	Lock Washer	
22	Nut M4	
23	Washer	
24	Spring	
25	Push On Retainer	
26, 29	Leaf Switch	200223
27	Tapping Screw M2 x 6	
28	Slider Switch	200776
30	Trip Rod	200845
31	Control Lever Assembly	200772
32	Tapping Screw M3 x 10	
33	P.C. Board Assembly	200846
34	Bracket Fixing M3 x 10.5	200847
35	Cue Rod Assembly	200778
36	Pin Pivot	200768
37	Gimble	200769
38	Tone Arm	200770
39	Cable Wire AWG 32 x 2C	
40	Cartridge CZ800-1	200108
42	Hinge	200785
43	Rivet	
44	Stylus ST800-1	200109

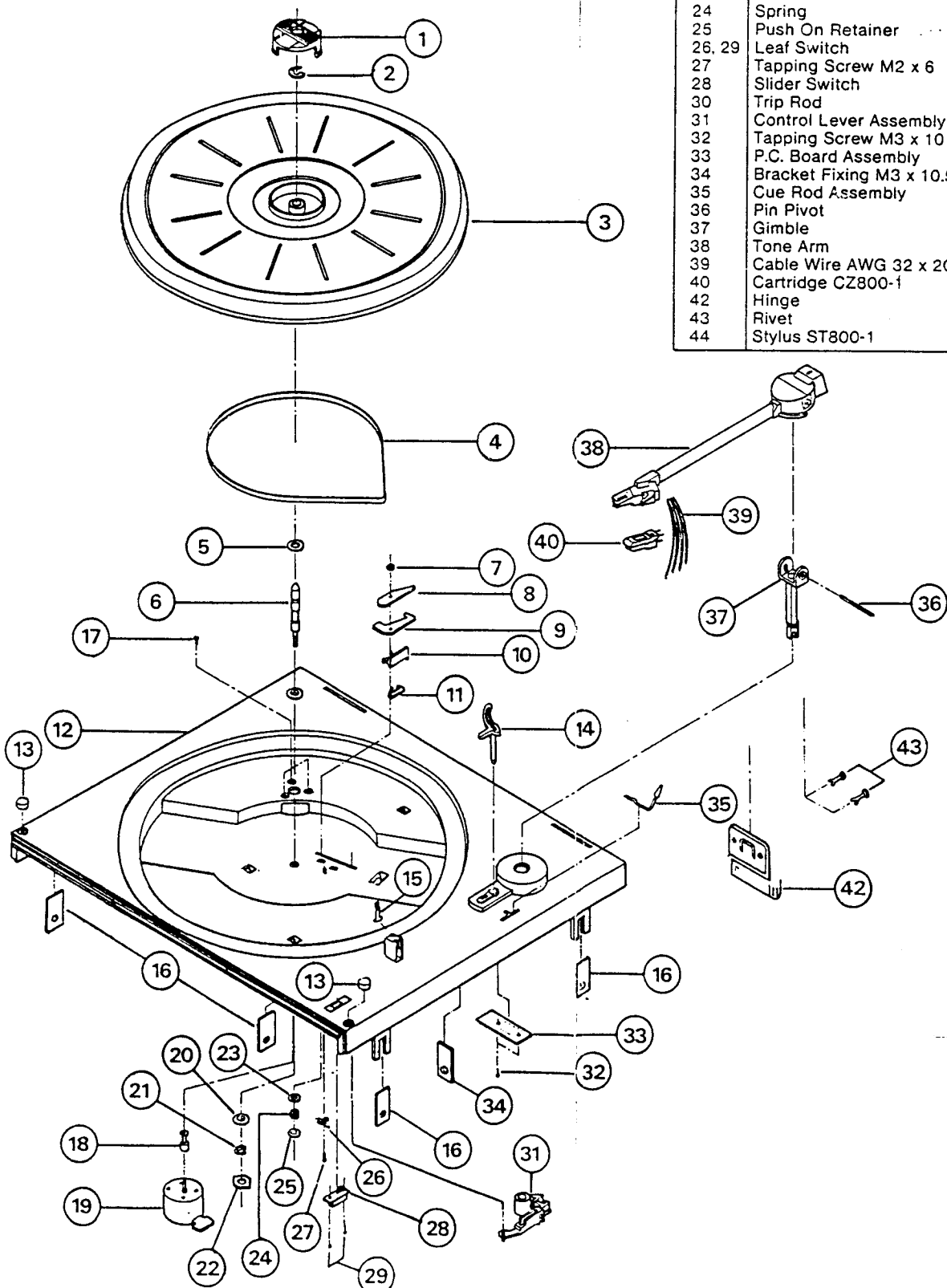

EXPLODED VIEW (Cassette Deck 1)

CASSETTE DECK PLAY

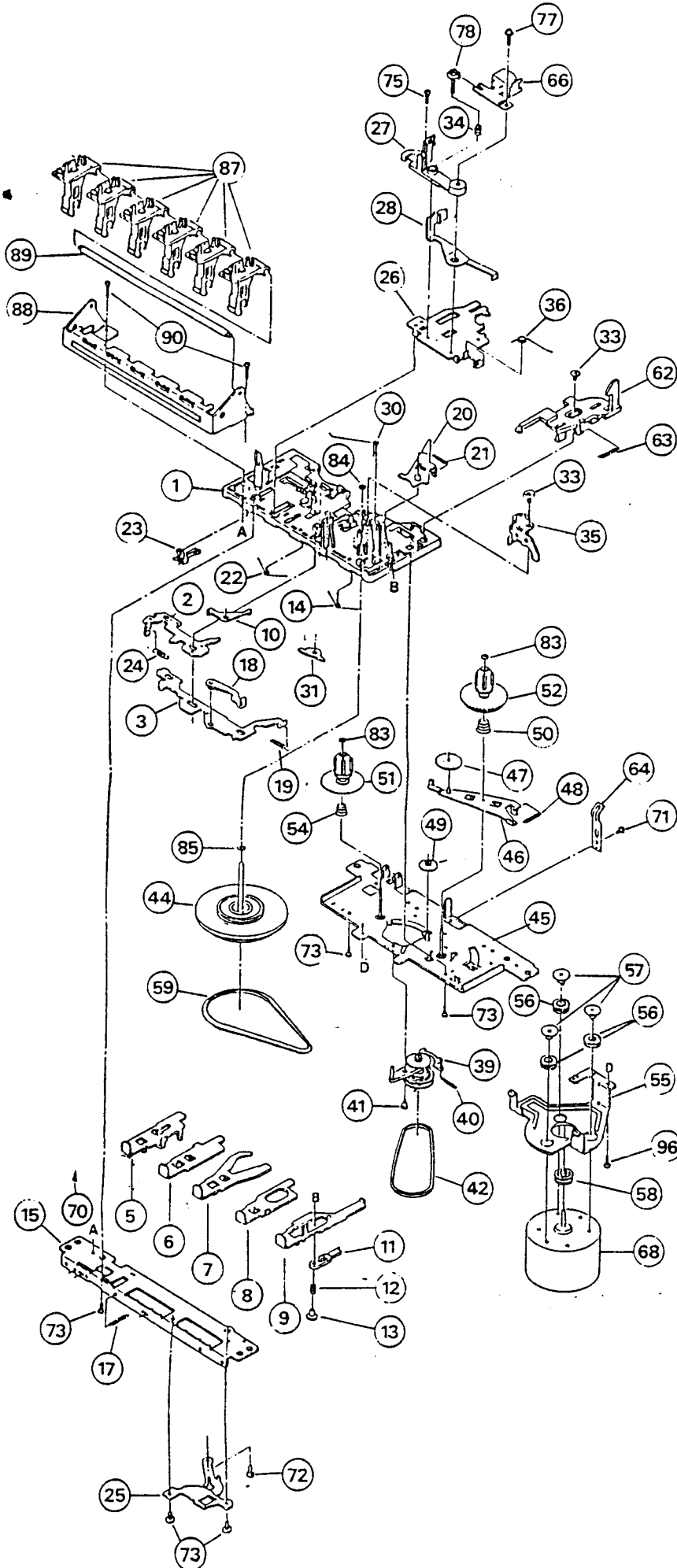

Ref.	Description	Part No.
1	Main Base Assy	201151
2	Switch	201152
3	Push Button Actuator	201153
4	Play Button Lever	201154
6	RWD Button Lever	201155
7	FF Button Lever	201156
8	Stop Button Lever	201157
9	Pause Button Lever Assy	201158
10	RWD Lever	201159
11	Pause Lever	201160
12	Pause Lever Spring	201161
13	Pause Stopper	201162
14	Button Lever Spring	201163
15	Sub Chassis	201164
17	Play Button Lever Spring	201165
18	E Kick Lever	201166
19	Actuator Spring	201167
20	Auto Lever	201168
21	Auton Lever Spring	201169
22	Button Lever Spring	201170
23	Leaf switch LSA-115R	201171
24	Switch Actuator Spring	201172
25	Metal Guide	201173
26	Head panel	201174
27	Head Bash	201175
28	Sensing Plate Assy	201176
30	Head Panel Spring	201177
31	PR Stopper	201178
33	PME Screw	201179
34	Spring	201180
35	Pinch Roller Assy	201181
36	Pinch Roller Spring	201182
39	RF Pulley Arm Assy	201183
40	RF Pulley Arm Spring	201184
42	RF Belt	201186
44	Flywheel Assy	201187
45	Reel Base Assy	201188
46	Take Up Gear Plate Assy	201189
47	Take Up Roller Gear	201190
48	T.G. Plate Spring	201191
49	FF Gear	201192
50	Back Tension Spring	201193
51	Supply Reel Assy	201194
52	Take Up reel Assy	201195
54	Back Tension Spring	201196
58	Motor Pulley	201200
59	Main Belt	201201
62	Eject Slide Lever	201202
63	Eject Slide Lever Spring	201203
64	Pack Spring	201204
66	Play Head	201205
67	Erase Head	201219
68	Motor	201206
87	Operation Lever	201207
88	Button Frame	201208
89	Button Lever Shaft	201209

CASSETTE DECK RECORD/PLAY

22	Button Lever Spring	201170
29	Erase Head Spring	201211
53	Record Safety Lever	201212
95	Leaf Switch MSW-1373NBK	201213

EXPLODED VIEW (Cassette Deck 2)

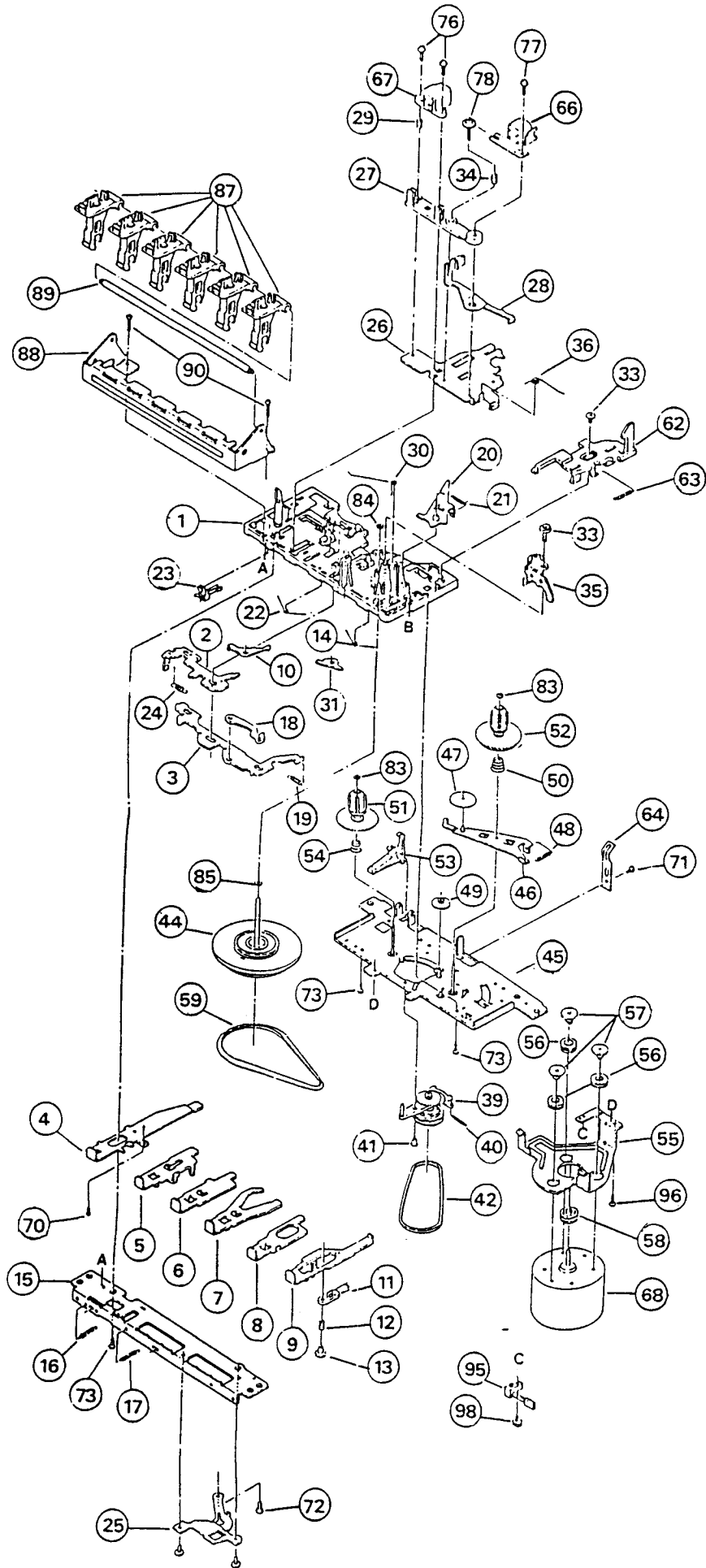

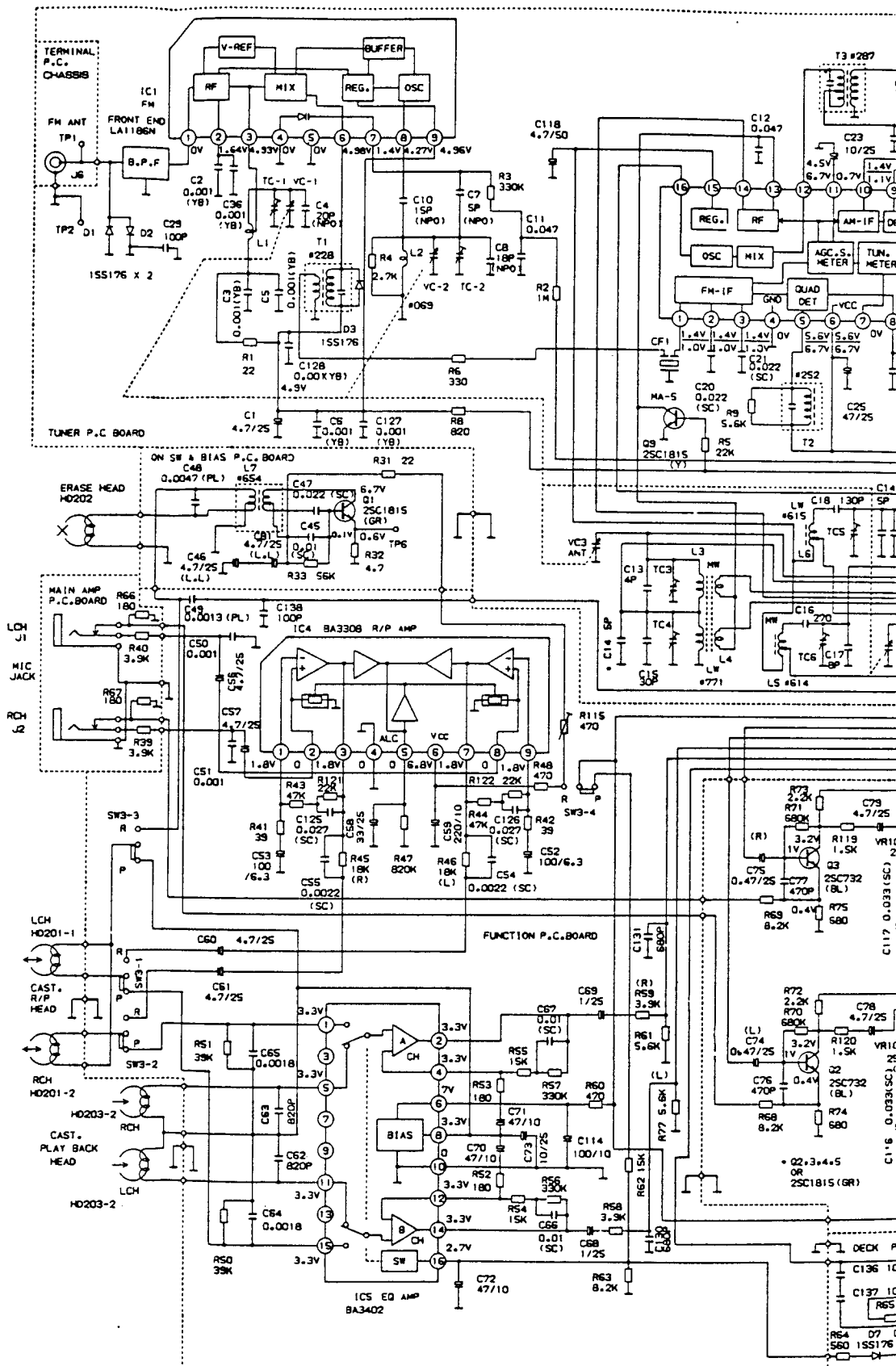

WARNING:
 REPLACEMENT PARTS WITH SPECIAL SAFETY CHARACTERISTICS ARE IDENTIFIED BY A Δ SHOWING ON THIS SCHEMATIC DIAGRAM. REPLACE THESE CRITICAL COMPONENTS WITH RECOMMENDED REPLACEMENT PARTS. DON'T DEGRADE THE SAFETY OF THIS SET THROUGH IMPROPER SERVICING. SERVICE PERSONNEL SHOULD MAKE LEAKAGE-CURRENT OR RESISTANCE MEASUREMENTS TO DETERMINE THAT EXPOSED PARTS ARE ACCEPTABLY INSULATED FROM THE SUPPLY CIRCUIT BEFORE RETURNING THE APPLIANCE TO THE CUSTOMER.

CIRCUIT DIAGRAM

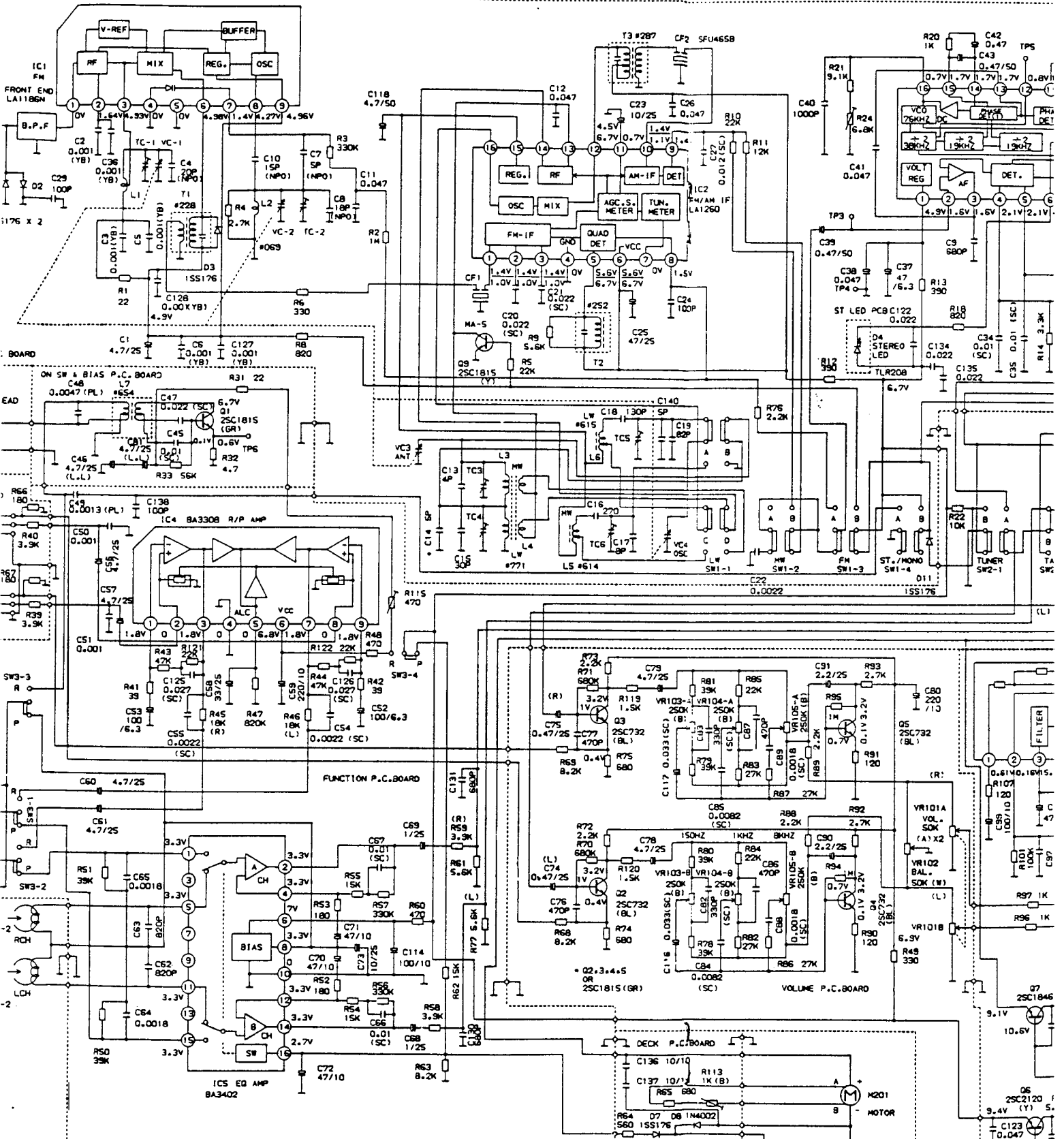

WARNING:
 REPLACEMENT PARTS WITH SPECIAL SAFETY CHARACTERISTICS ARE IDENTIFIED BY A SHOWING ON THIS SCHEMATIC DIAGRAM. REPLACE THESE CRITICAL COMPONENTS WITH RECOMMENDED REPLACEMENT PARTS. DON'T DEGRADE THE SAFETY OF THIS SET THROUGH IMPROPER SERVICING. SERVICE PERSONNEL SHOULD MAKE LEAKAGE-CURRENT OR RESISTANCE MEASUREMENTS TO DETERMINE THAT EXPOSED PARTS ARE ACCEPTABLY INSULATED FROM THE SUPPLY CIRCUIT BEFORE RETURNING THE APPLIANCE TO THE CUSTOMER.

SW202 P.B. DECK
 SW201 R/P DECK

G5 2SC1210 (Y) 5.0
 C123 0.047
 C124 0.047
 C108 100/16

CIRCUIT DIAGRAM

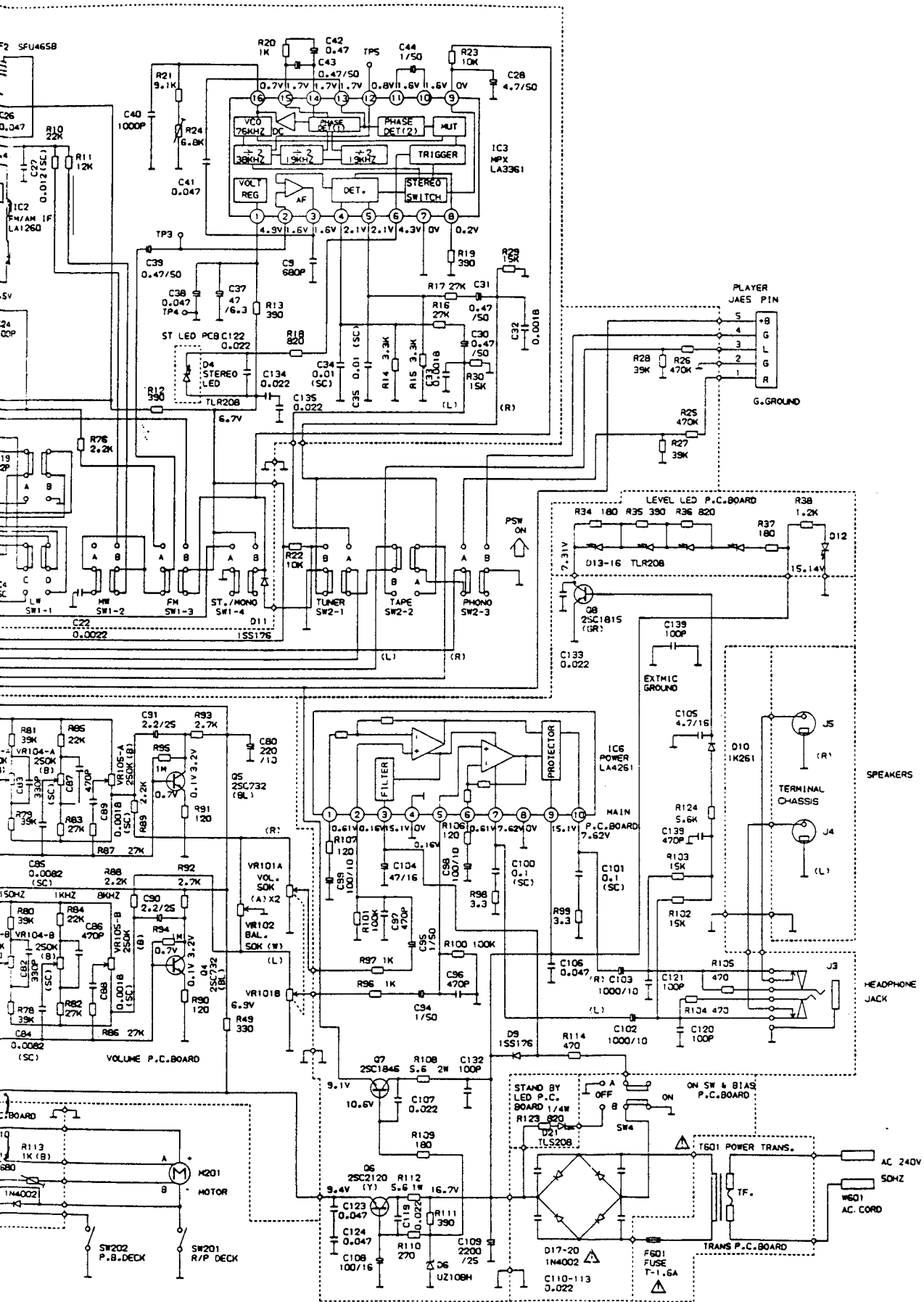

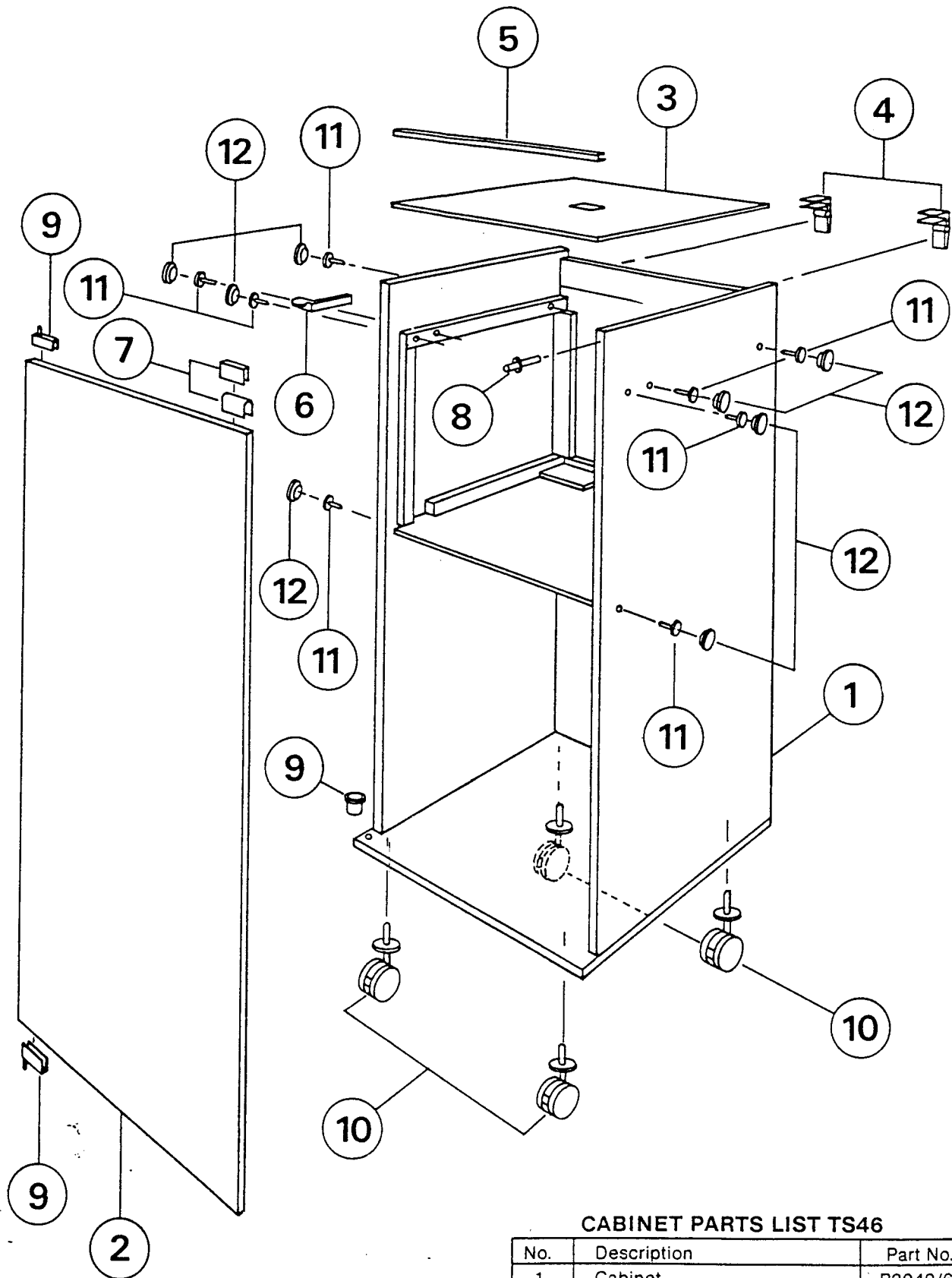

CABINET PARTS LIST TS46

No.	Description	Part No.
1	Cabinet	B3049/6
2	Glass Door	70004
3	Lid Record Deck	70003
4	Hinge Lid	90008
5	Trim Lid	90090
6	Rest Lid	
7	Handle Assy.	93003
8	Magnetic Lock	90016
9	Hinge Glass Door Kit	90011
10	Castors	90100
11	Screws	
12	Screw Caps	B1044

FUNCTION P.C.B. (Top View)

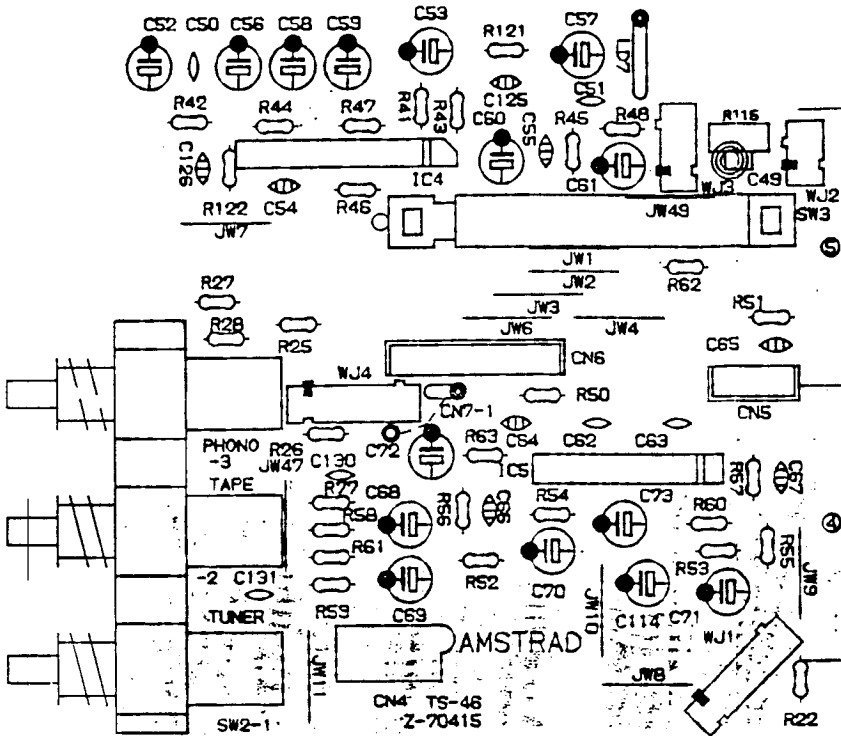

STEREO LED P.C.B.

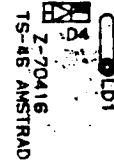

(Top View)

STEREO LED P.C.B.

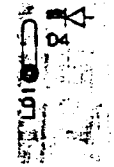

(Bottom View)

FUNCTION P.C.B. (Bottom View)

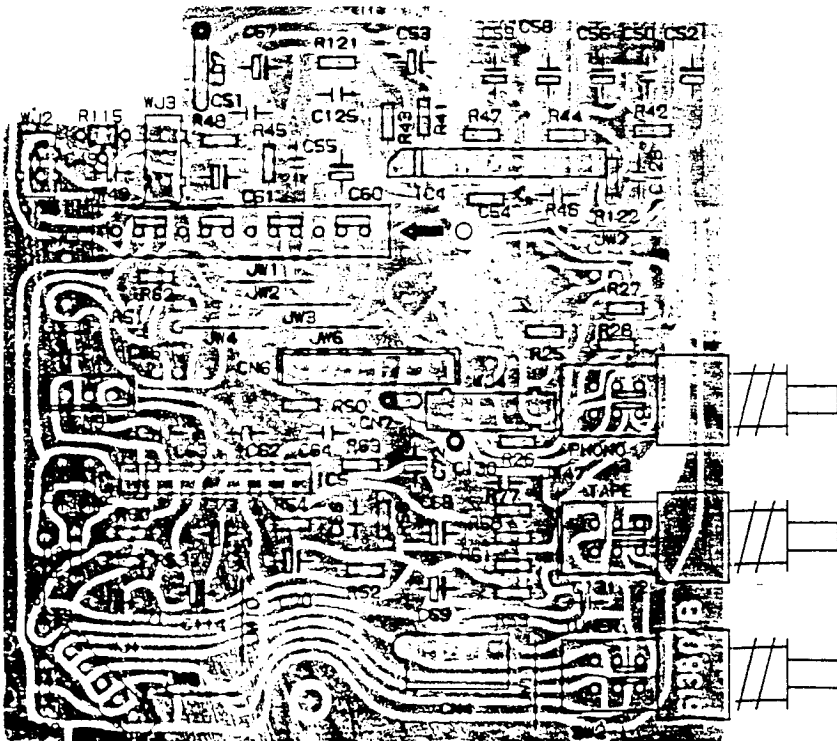

STANDBY LED P.C.B.

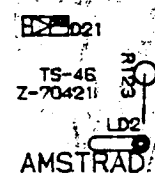

(Top View)

STANDBY LED P.C.B.

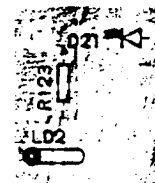

(Bottom View)

TERMINAL CHASSIS P.C.B. (Top View)

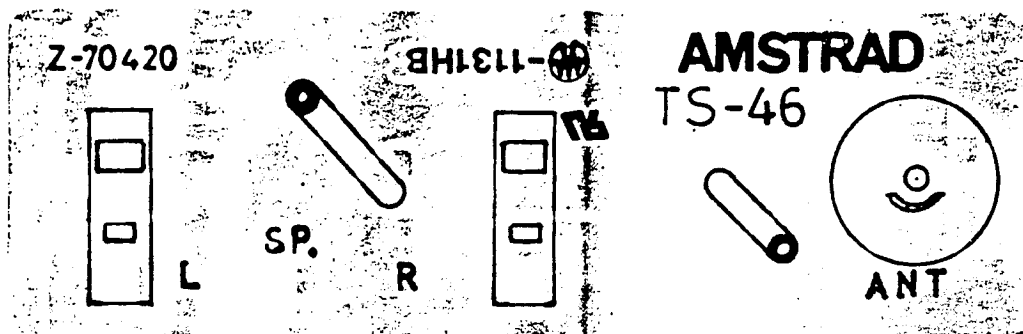

TERMINAL CHASSIS P.C.B. (Bottom View)



DECK P.C.B. (Top View)

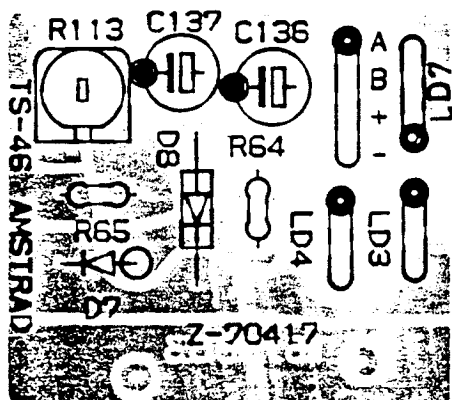

DECK P.C.B. (Bottom View)

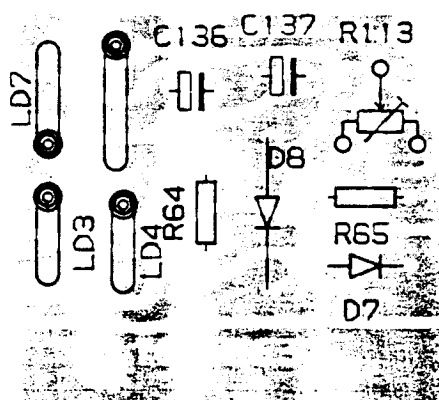

POWER SUPPLY P.C.B. (Top View)



POWER SUPPLY P.C.B. (Bottom View)

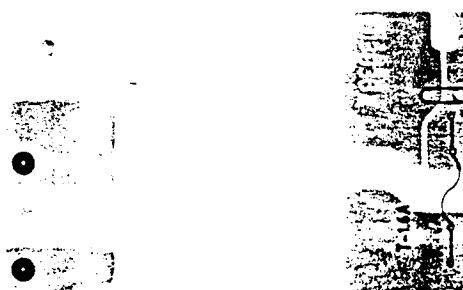

AMP P.C.B. (Top View)

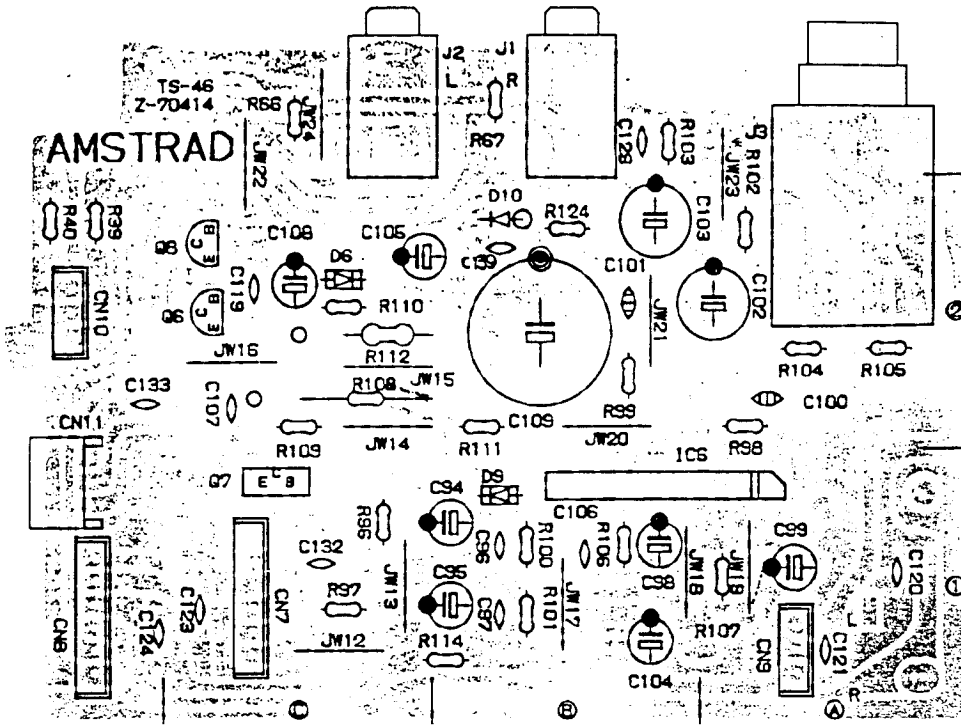

AMP P.C.B. (Bottom View)

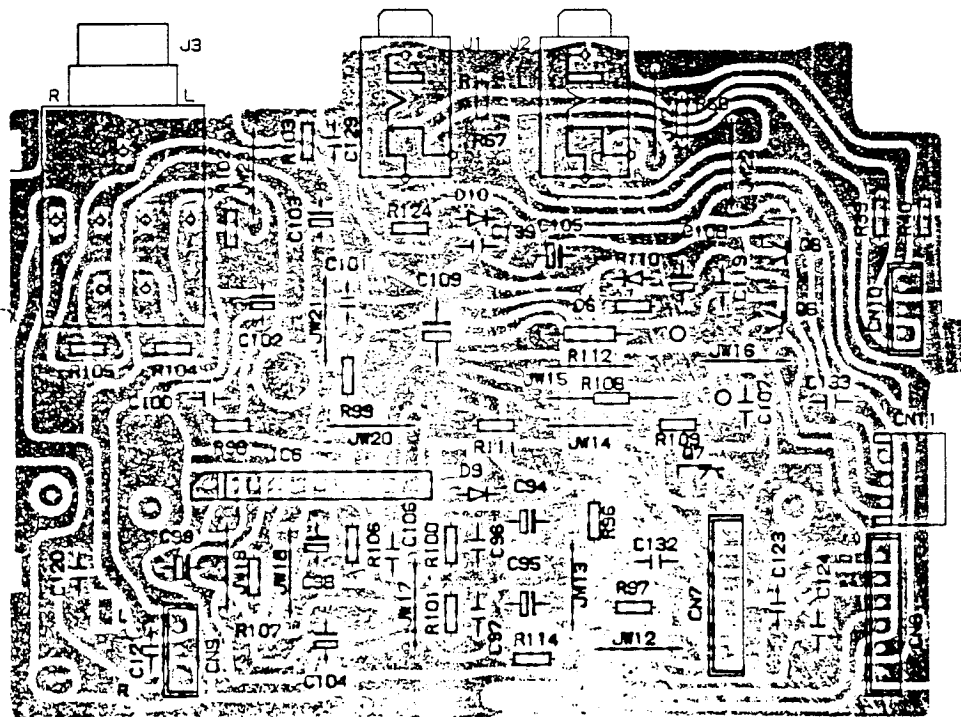

RECTIFIER & BIAS P.C.B. (Top View)

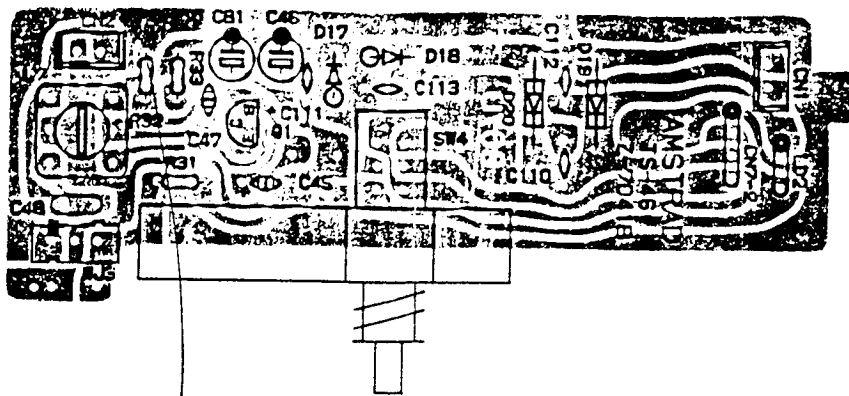

RECTIFIER & BIAS P.C.B. (Bottom View)

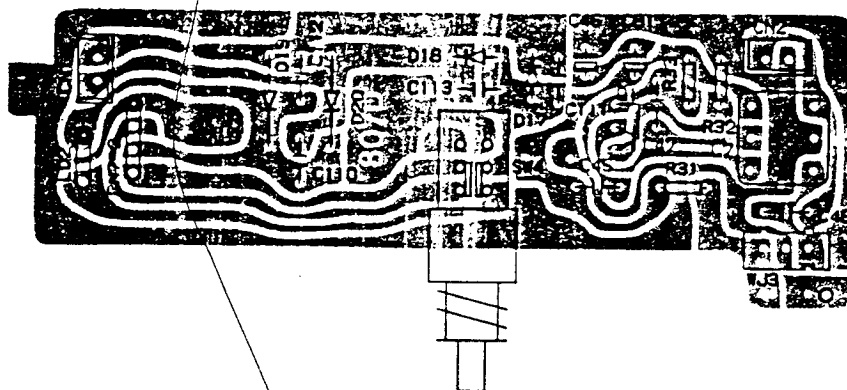

LEVEL LED P.C.B. (TOP VIEW)

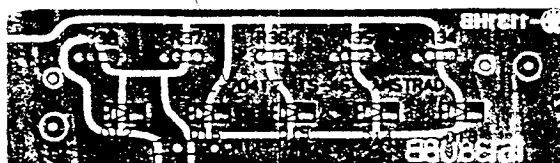

LEVEL LED P.C.B. (BOTTOM VIEW)

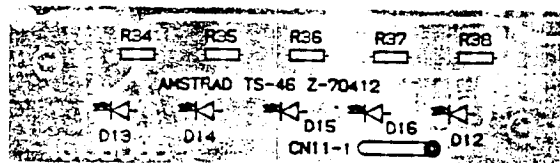

VOL P.C.B. (TOP VIEW)

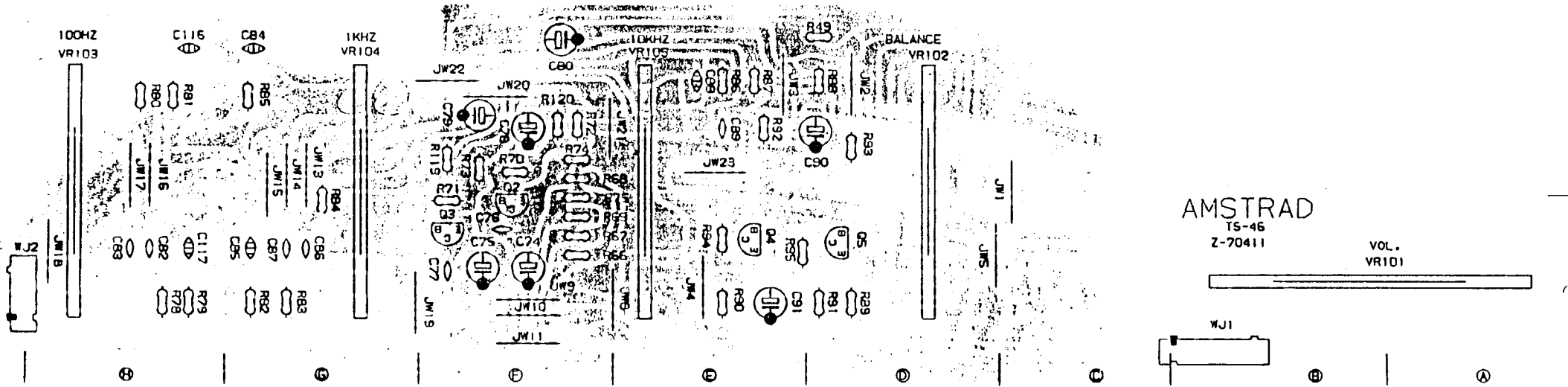

VOL P.C.B. (BOTTOM VIEW)

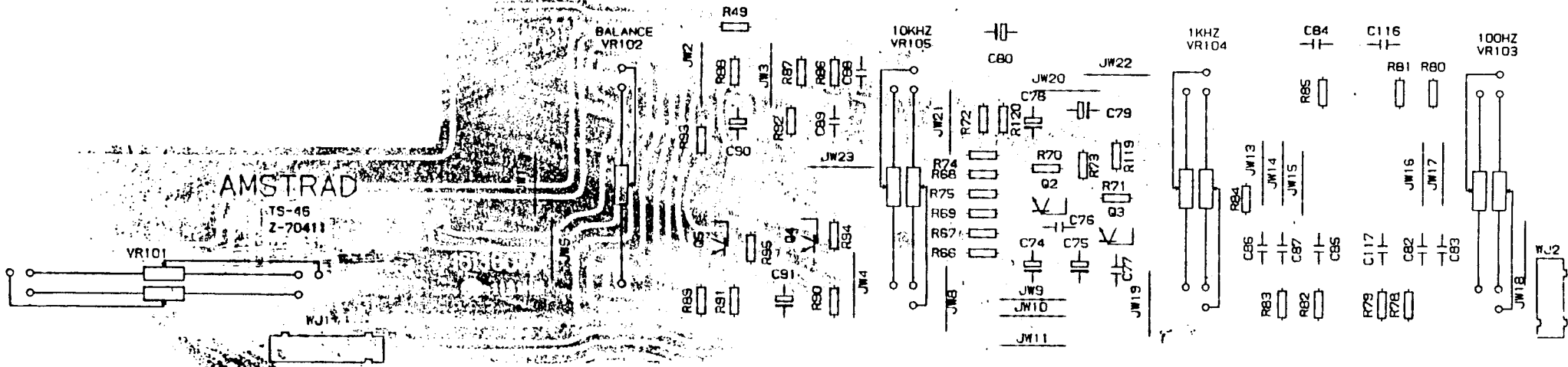

ELECTRICAL PARTS LIST

Description	Circuit Reference	Part No.
Carbon Film Resistors		
3.3ohm	R98, 99	10073
4.7ohm	R32	10077
22ohm	R1, 31	10016
39ohm	R4, 41	150467
120ohm	R90, 91, 106, 107	10034
180ohm	R3, 34, 37, 52, 53, 66, 67, 109	10037
270ohm	R110	10042
330ohm	R6, 49	10044
390ohm	R12, 13, 19, 35, 111	10046
470ohm	R48, 60, 104, 105, 114, 115	10048
560ohm	R64	10050
680ohm	R65, 74, 75	10052
820ohm	R8, 18, 36, 123	10054
1kohm	R20, 96, 97	10061
1.2kohm	R38	10063
1.5kohm	R119, 120	10065
2.2kohm	R72, 73, 76, 88, 89	10069
2.7kohm	R4, 92, 93	10068
3.3kohm	R14, 15	10073
3.9kohm	R39, 40, 58, 59	10075
5.6kohm	R9, 61, 77, 124	10079
8.2kohm	R63, 68, 69	10083
9.1kohm	R21	152193
10kohm	R22, 23	10085
12kohm	R11	10087
15kohm	R29, 30, 54, 55, 62, 102, 103	10089
18kohm	R45, 46	10091
22kohm	R5, 10, 84, 85, 121, 122	10093
27kohm	R16, 17, 82, 83, 86, 87	10095
39kohm	R50, 51, 78-81	10099
47kohm	R43, 44	10101
56kohm	R33	10103
100kohm	R100, 101	10109
330kohm	R3, 56, 57	10121
470kohm	R25, 26	10125
680kohm	R70, 71	10129
820kohm	R47, 123	10130
1Mohm	R2, 94, 95	10147
Metal Resistors		
5.6ohm/1W	R112	200961
5.6ohm/2W	R108	200962
Ceramic Capacitors		
4pF	C13	150487
5pF	C7, 14, 140	200507
8pF	C17	810310
15pF	C10	400106
18pF	C8	150512
20pF	C4	150528
30pF	C15	200973
82pF	C19	150517
100pF	C24, 29, 120, 121, 129, 132	24016
330pF	C82, 83	150518
470pF	C76, 77, 86, 87, 96, 97, 139	24004
680pF	C9, 130, 131	806223
820pF	C62, 63	800209
0.001uF	C2, 3, 5, 6, 36, 50, 51, 127, 128	24027
0.0018uF	C32, 33	200974
0.0022uF	C22, 122	200975
0.01uF	C34, 35, 100, 101	810312
0.012uF	C27	200976
0.022uF	C110-113, 107, 119, 133-135	24013
0.027uF	C125, 126	200977
0.047uF	C11, 12, 26, 38, 41, 106, 123, 124	24015
Polypropylene Capacitors		
100pF	C138	200963
1300pF	C49	200964
4700pF	C48	200965
Semiconductors		
0.0018uF	C64, 65, 88, 89	200969
0.0022uF	C54, 55	200970
0.0082uF	C84, 85	200971
0.01uF	C45, 66, 67	151583
0.022uF	C20, 21, 47	200972
0.033uF	C116, 117	151586

Description	Circuit Reference	Part No.
Electrolytic Capacitors		
0.47uF/25V	C30	201236
0.47uF/50V	C31, 39, 42, 43, 74, 75	200966
1uF/50V	C44, 68, 69, 94, 95	20062
2.2uF/25V	C90, 91	201238
4.7uF/25V	C1, 28, 56, 60, 61, 78, 79, 81, 105, 118	151599
10uF/25V	C23, 73, 136, 137	200967
33uF/25V	C58	151637
47uF/25V	C25, 37, 70-72, 104	151640
100uF/10V	C52, 53, 98, 99, 102, 103	20028
100uF/16V	C108, 114	20028
220uF/10V	C59, 80	170611
2200uF/25V	C109	200968
Ref.	Description	Part No.
I.C.s		
IC1	LA1186N Front End	201068
IC2	LA1260 AM/FM IF	201069
IC3	LA3361 MPX	200402
IC4	BA3308 Rec Amp	200901
IC5	BA3402 Play Amp	200902
IC6	LA4261 Power Amp	200900
Transistors		
Q1-5, 8, 9	TR 2SC1815/2SC732	171137
Q6	TR 2SC2120	170113
Q7	TR 2SC1846	201073
Diodes		
D1-3, 7, 9, 11	D. IN4148/1SS76	200241
D8, 17-20	D. IN4002	15008
D4, 12-16	D. LED Stereo 220	200903
D6	D. UZ10BH/MZT10D	201079
D10	D. IK261/IN60	15001
D21	D. LED Standby 292	200955
Sockets		
J4, 5	Speaker Jack	200904
J6	DIN FM Antenna Socket	200905
J1, 2	Jack Socket 3.5mm	200906
J3	Jack Headphone 6.5mm	200956
Potentiometers		
VR101	Volume 50k ohm	200907
VR102	Balance 50k ohm	200908
VR103-105	Equalizer 250k ohm	200909
R24	MPX ADJ S.F. 6.8k ohm	200957
R113	Speed ADJ DECK S.F. 1k ohm	200958
R115	BIAS ADJ S.F. 470ohm	200959
Switches		
SW4	Power Switch	200910
SW2	Function Switch	200954
SW3	Record Switch	200956
SW1	Band Push Switch	200957
Coils		
L1	Coil Spring 112M163	200911
L2	Coil FM OSC 114M069	201083
L3/4	Coil AM/FM 111B711	200912
L5	Coil MW OSC 113M614	201085
L6	Coil LW OSC 113M615	201086
L7	Coil TAPE BIAS 113M654	200913
T1	Coil FM IFT 11LM228	201089
T2	Coil FM DETECTOR 11JM252	201090
T3-	Coil AM IFT 11AM287	201091
Variable Capacitors		
TC4, 5	TRIMMER 16pF	200914
TC1-4/VC1-4	VARIABLE CAPACITOR	200915
Filters		
CF1	Ceramic Filter 10.7MHz	993034
CF2	Ceramic Filter 465kHz	800114
BPF	Print Filter	200917
Miscellaneous		
T601	Power Transformer	200918
F601	Fuse T1.6A	200920

WIRING DIAGRAM

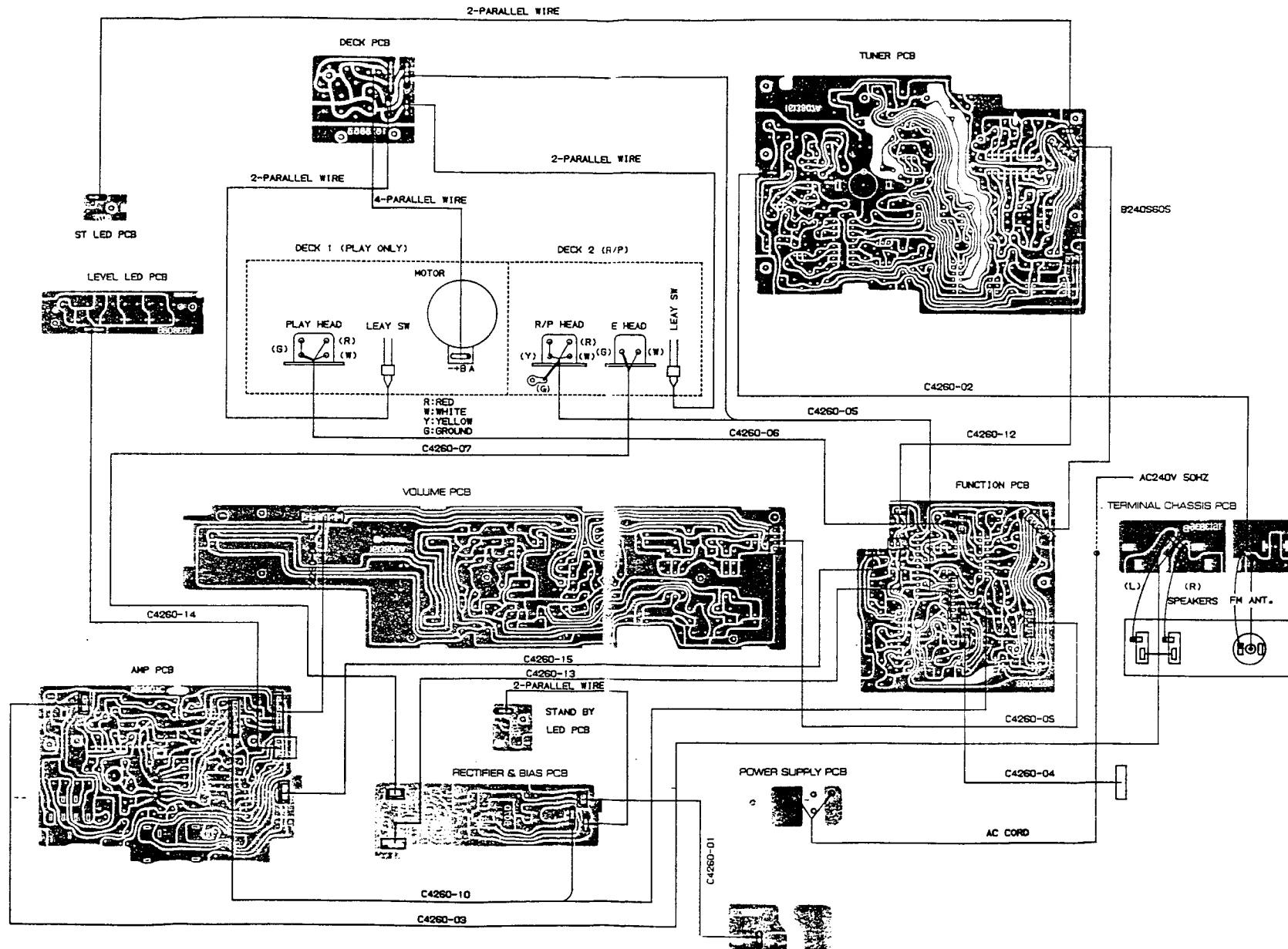

CABINET PARTS LIST

A-1	Front Panel Assy	200921
A-2	Dial Window	200960
A-3	Tuning Knob	200922
A-4	Volume Knob	200923
A-5	Function Knob	200924
A-6	Equalizer Knob	200925
A-7	Dial Pointer	200926
A-8	Cassette Door 1	200927
A-9	Cassette Door 2	200928
A-10	Volume Indicator	200929
A-11	Back Screen	200930
A-12	Terminal Plate	
A-14	Record Key	200932
A-15	Play Key S	200933
A-16	Play Key B	200934
A-17	Record Key	200935
A-18	FF Key	200936
A-19	Stop Key	200937
A-20	Pause key	200938
B-1	Knob Chassis	200939
B-2	Tuning Knob Holder	200940
B-3	Dial Drum	200941
B-4	Tuner PCB Holder	
B-5	Pre Amp PCB Holder	
B-6	Pulley Holder	
B-7	PCB Holder	
B-8	Deck Holder	200946
B-9	Function PCB Holder	
B-10	Chassis Fixing Metal	200948
B-11	Tuning Pulley	200949
B-12	Drum Spring	200950
B-18	Record Spring	200951
B-19	Rec Spring Holder	
B-20	Damper Plate	200953
B-21	Door Spring	200954

CHASSIS DRAWING

