

ATLAS MAINS THREE

Circuit.—The H.F. valve, AC/SG/VM (V1) is preceded by a tuned secondary aerial transformer, the bias for which is provided by a separate rectifier system, which also supplies the bias potential for the output valve. The actual voltage is obtained from a potentiometer at the junction of R6 and R7. The variable mu characteristic of the valve is not used for controlling volume.

The anode lead is taken to a tapping on the tuned anode coil and the anode circuit is decoupled.

The detector valve, AC/2HLL (V2), works as a power grid detector, with a .0001 mfd. grid condenser and .25 megohm grid leak. Bias for the pick-up is provided from the bias potential for the H.F. valve.

Reaction is used and a stabilising resistance to provide smooth control is included in the lead from the anode. The anode circuit consists of a by-pass condenser, H.F. choke and coupling resistance to the parallel-fed L.F. transformer.

Decoupling consists of a 20,000 ohm resistance and 2 mfd. condenser.

The output valve, 41MP. (V3) is an indirectly heated triode, and the L.S. circuit is conventional.

The mains equipment is in two sections, with one mains transformer. One high voltage winding is connected to a full wave metal rectifier on the voltage doubling circuit for H.T. and another winding is connected to a half wave metal rectifier for the grid bias voltages. This method allows all the cathodes to be at chassis potential. As with battery sets, the positive of the G.B. circuit is connected to chassis.

VALVE READINGS

Valve.	Type.	Electrode.	Volts.	M.A.
1	A.C.	anode ...	185	15
	S.G., V.M.	screen ...	110	—
2	A.C.2	anode ...	90	3.5
3	H.T.
	41M.P.	anode ...	215	20

Quick Tests.—The speaker transformer is covered and only two points of H.T. potential are accessible.

Voltages between the following and chassis :—

Positive terminal on electrolytic condenser (H.T. unsmoothed) 360 volts.*

Anode of S.G. valve, 190 volts.

Removing Chassis.—Remove tuning knobs (grub screw), pull off the wave change and the reaction knobs, and remove four screws from underneath. Cut the strings holding the L.S. leads and lift the chassis out.

Set Chassis.—To reach the components in the set chassis undo the two bolts holding the flanges at the side of the outer casing and undo the two bolts alongside the tuning dial.

Ease the control section outwards and unsolder the following leads—two to the terminal strip at the right hand end (looking from the rear) and three from the terminal strip at the other end. Unsolder the lead from V2 grid condenser (C6) and the lead from the H.F. intervalve coil to the S.G. anode.

The two sections can then be separated. Note that the upper terminal of four is blank, as is the middle one of three on the valve deck section.

Power Pack.—To separate the valve deck from the power pack remove two bolts holding the stays at the ends and slacken the two bolts at the end of the cover over the terminal strip.

The bolts fit into grooves in the power pack side, so that when the ten links (soldering tags) between the chassis have been unsoldered, the two can be separated without removing the bolts.

If trouble is definitely traced to the power pack this can be removed without dismantling the set chassis.

Quick Tests at Power Pack Terminals (with chassis out).—To reach these,

* In taking this reading take care not to cause a short circuit to the casing.



Screen-grid, detector and pentode valves form the circuit combination of the Atlas 334 receiver by H. Clarke & Co. (Manchester), Ltd.

slacken two bolts at the ends of the terminal cover that reaches from the S.G. to the output valve, and slip the flanges from underneath the heads.

Voltages between the terminals and chassis, counting from output valve end :—

- (1) V3 valve anode, +215 volts.
- (2) H.T. + smoothed +220 volts.
- (3) Feed to det. between R9 and R5, +150 volts.
- (4) Screen of V1, +110 volts.
- (5) Bias for V3, -8 volts.
- (6) Pick-up, 0 volts.
- (7) Bias for V1, .75 volts.
- (8) Aerial, 0 volts.
- (9) Chassis, 0 volts.

General Notes.—The power pack is the combined H.T., L.T. and G.B. eliminator, and though the rectifier is drawn diagrammatically as two separate rectifiers, they are
(Continued on opposite page.)

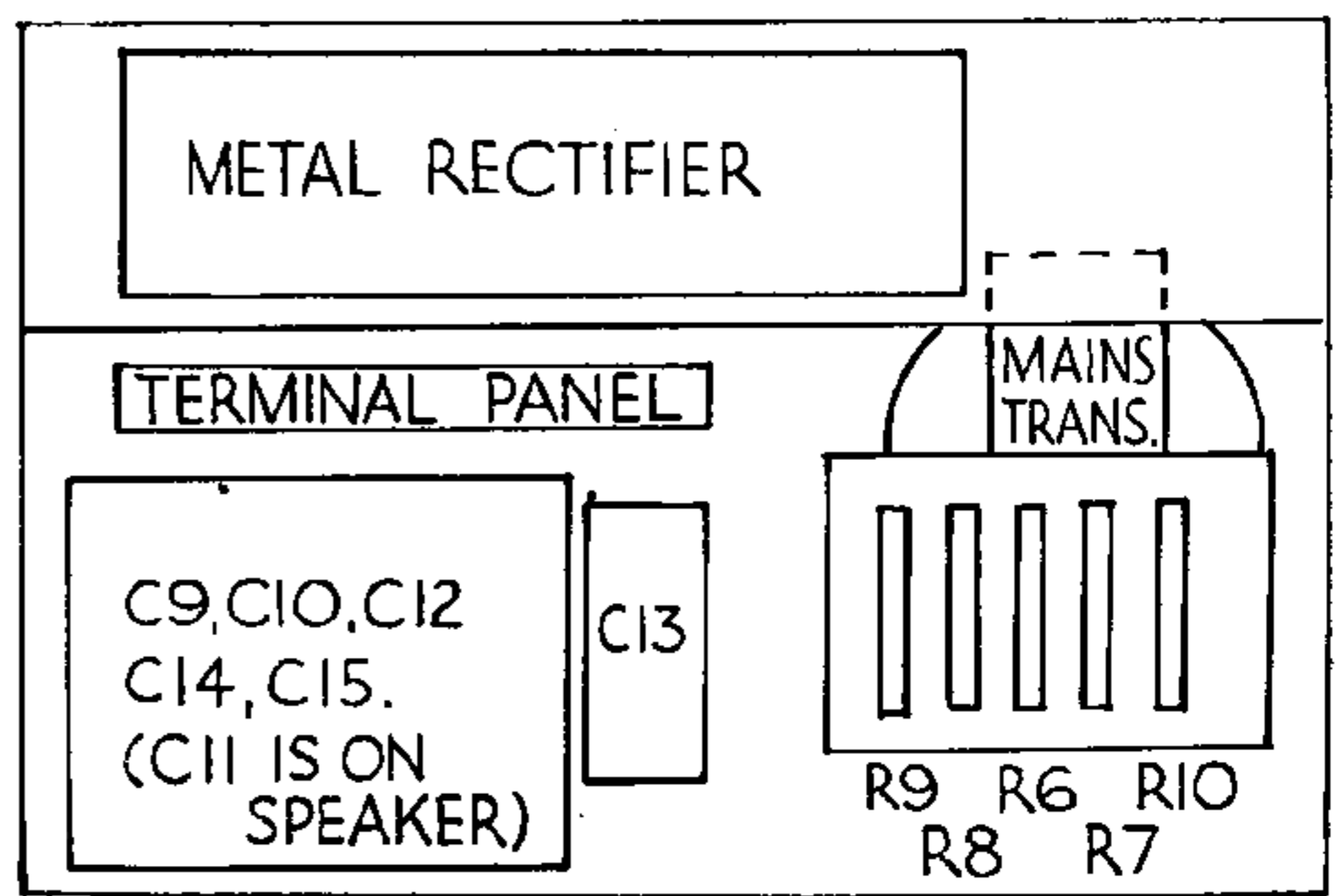
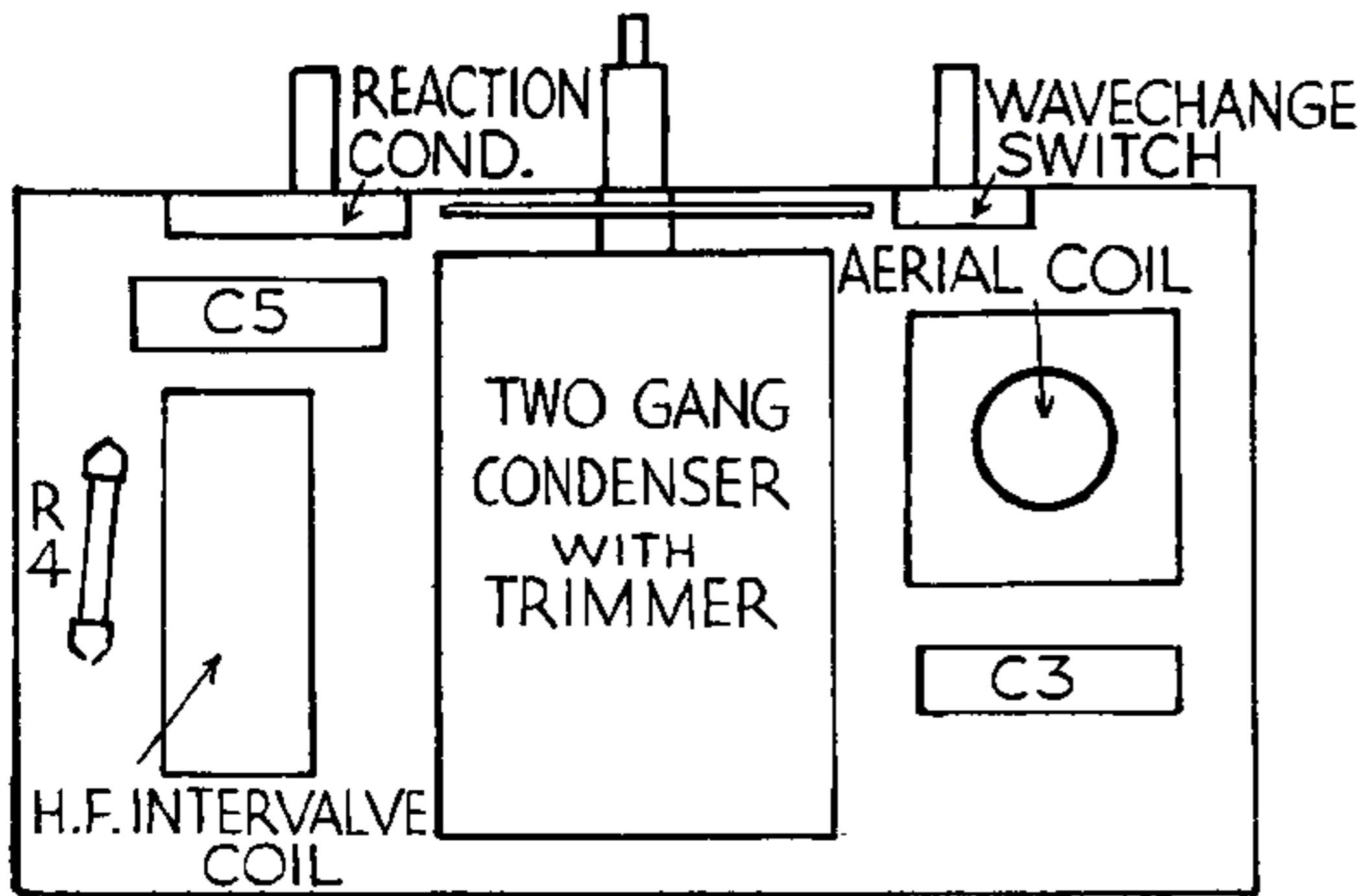

ATLAS MODEL 334 BY CLARKE'S (Contd.)

virtually one with the set negative taken from a tapping as in many H.T. batteries. With the exception of R4 and C5, all the decoupling components are inside the power pack unit.

Changing Dials.—Release the control section from the remainder as described for removing it, and unscrew the four holding screws. It may be necessary to bend the front slightly forward to reach the lower screw. Remove the dial and replace with new one.

Reassembling Chassis.—Lay the valve deck and the control panel in their proper positions and resolder the two leads inside, one to the coil and the other to the grid condenser of V2 (C6).

Replace the corner bolts holding the two sections together and resolder the leads to the terminal panels at the ends.

Fit the power pack to the chassis with the slots under the heads of the two holding bolts and fix the two bolts holding the stays at the ends of the power pack.

Solder the connections between the two terminal strips and, after slipping the slots in the terminal strip cover underneath the heads of the bolts, tighten the latter.

There is no danger of the nuts turning as they are square and are bearing against the side of the valve deck.

The Atlas "straight" mains three is made in two sections—receiver and power pack. Above is the top of the set chassis (left) and the underneath of the power pack.

On the right is the sub-chassis layout of components in the Atlas 334 by H. Clarke & Co. The numbers 1 to 9 are referred to in "Quick Tests."

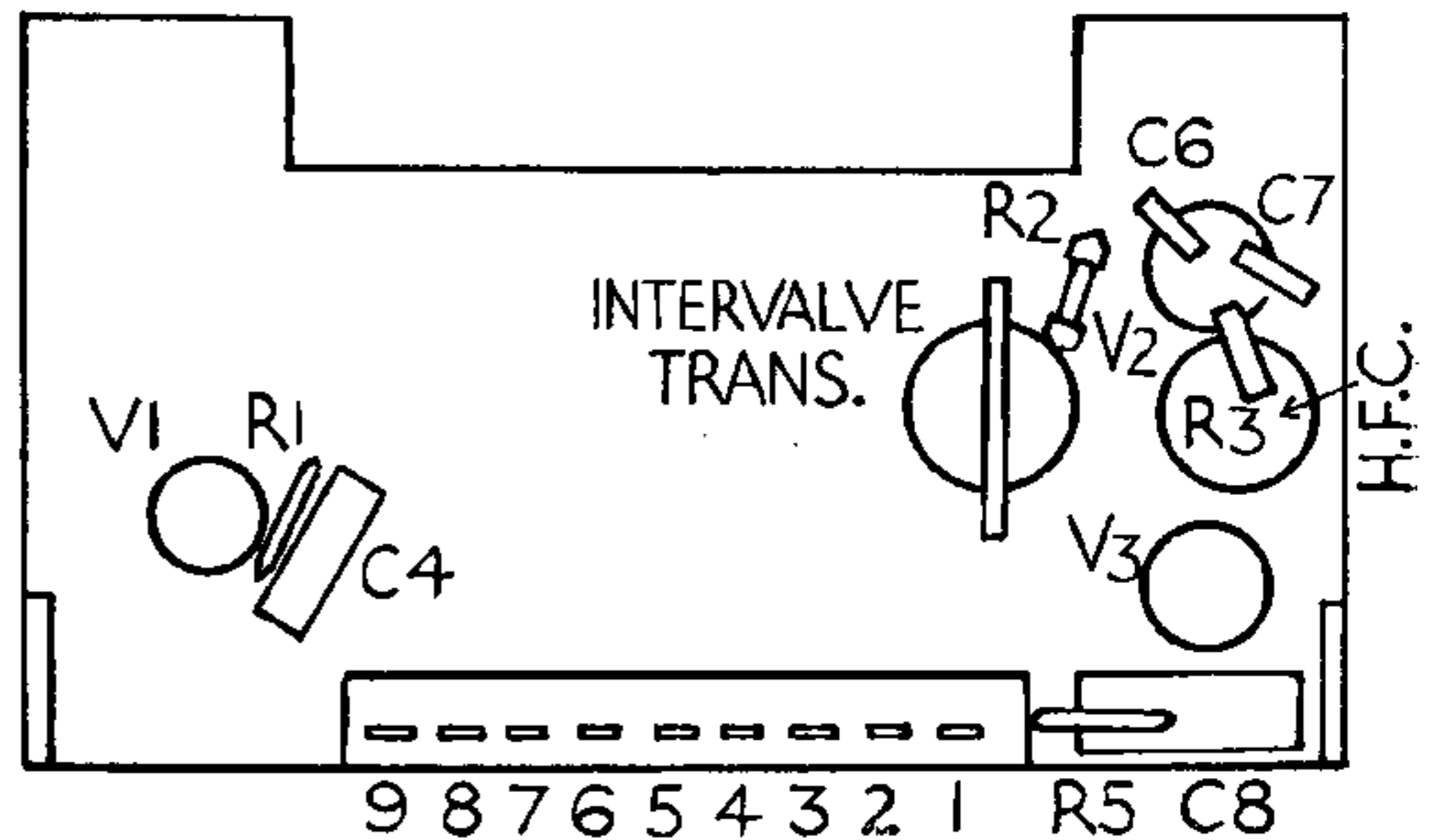

CONDENSERS

C.	Purpose.	Mfd.
1	Aerial series condenser00025
2	Mains aerial001
3	Prevents short-circuit of bias on V1.	.5
4	V1 screen1
5	V1 anode decoupling5
6	V2 grid0001
7	V2 anode by-pass0005
8	Filter feed to L.F. transformer	.5
9	V2 anode decoupling ...	2
10	H.T. smoothing ...	4
11	H.T. smoothing ...	4
12,13	Voltage doubler circuit ...	2 and 2
14,15	Smoothing bias circuit ...	2 and 1

RESISTANCES

R.	Purpose.	Ohms.
1	Lower part of V1 screen ptr. ...	50,000
2	V2 grid leak25 meg.
3	Stabiliser in reaction circuit, anode V2.	125
4	V1 anode decoupling ...	2,000
5	V2 anode coupling ...	20,000
6	Bias ptr.1 meg.
7		.5 meg.
8	Top part of V1 screen ptr. ...	100,000
9	V2 anode decoupling ...	20,000
10	Smoothing bias circuit ...	50,000
—	Field coil ...	4,000
—	Primary of output transformer	200

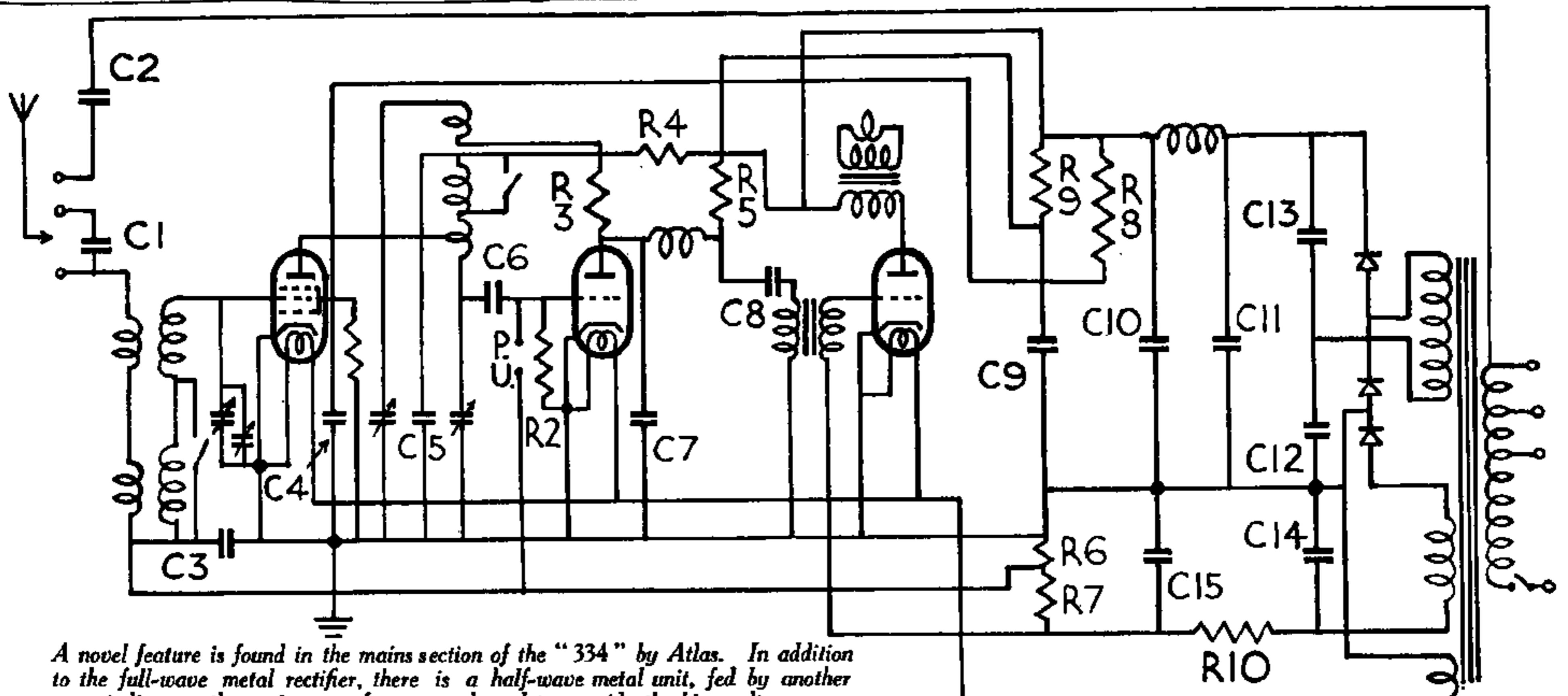

A novel feature is found in the mains section of the "334" by Atlas. In addition to the full-wave metal rectifier, there is a half-wave metal unit, fed by another winding on the mains transformer, and used to provide the bias voltages.