

DPA616

Service Manual



www.audac.eu

Index

Specification	5
Exploded View	6
Exploded View Part List	7
Schematic Diagram	8–14
Electrical Part List	15–22
Printed Circuit Board Diagram	23–25
Personal Notes	26–27

Specifications

Output Power (1 kHz, THD 1%)	Stereo @ 4 Ohm Stereo @ 8 Ohm Bridge @ 8 Ohm	16 x 60 Watt 16 x 30 Watt 8 x 120 Watt
Frequency response		20 Hz – 20 kHz
Signal to Noise Ratio		> 100 dB
Total Harmonic Distortion + Noise		< 0.1%
Damping factor (8 Ohm)		110
Common Mode Rejection		> 65 dB
Crosstalk	Paired channels Unpaired channels	> 65 dB > 110 dB
Inputs	Type Sensitivity Impedance Connectors	8 x Stereo Balanced Line (16 Ch) –20 dB ~ +20 dB 20 k Ohm 3–pin Terminal block – 3.81 mm
Outputs	Type Connectors	8 x Stereo Loudspeaker (16 Ch) 4–pin Terminal block – 5.08 mm
Controls		Gain Stereo / Bridge & Parallel switch
Indicators		Power Clip (rear)
Protection		DC–Short circuit Over heating Over load
Cooling system		Temperature controlled fan
Amplifier technology		Class–D
Power supply	Type Range	Switching mode 100–240 V AC / 50–60 Hz
Power consumption	Idle 1/8 Rated power 1/3 Rated power	47 Watt 200 Watt 400 Watt
Weight		8.2 Kg
Dimensions (W x H x D)		482 x 88 x 322 mm
Unit height		2HE
Recommended accessories	Procab CLA830 Procab CLA832 Procab CLA835	Terminal block signal connection cable RCA / Cinch to Terminal block signal connection cable XLR Female to Terminal block signal connection cable

Exploded view

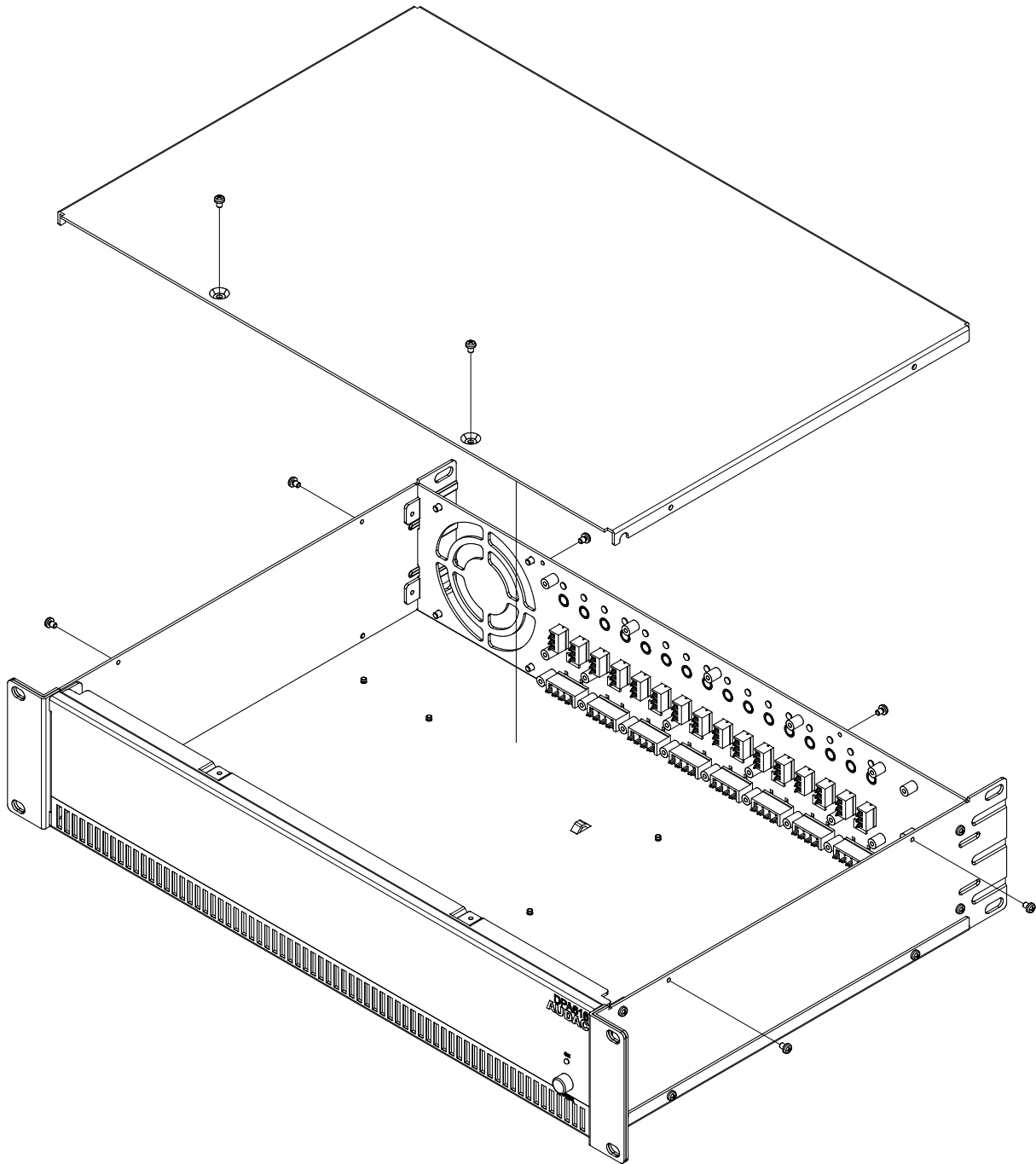

Assy Parts List

AUDAC part code	Description	Q'TY
AU895743190	BOX KIT 570X430X190MM (FOAM)	1
	Chassis for DPA616	1
AU056160000	CHASSIS MAIN KIT (FILTER)	1
AU056160001	SIDE FRAME KIT (RACK EAR, 6XM3)	2
AU056160003	TOP COVER KIT (8 SCREW)	1
	Fuse T2.5L/250V	1
AU515002005	DPA616 – POWER SUPPLY COMPLETE ASSEMBLY	1
AU515002006	POW2 & DPA616 – POWER AMPLIFIER BOARD V2.0 – ASSY	1
AU515002007	DPA616 – IO BOARD V1.2 – ASSY	1
AU515001002	R2 & M2 – CONVERTER PCB – ASSEMBLED (1 PCS)	1
AU515001003	R2 & M2 – POWER FACTOR CORRECTOR PCB – ASSEMBLED	1
AU520002003	CABLE SET FOR R2 & M2 POWER AMPLIFIER KIT	1
AU515002003	R2 & M2 – POW KIT POWER AMPLIFIER COMPLETE ASSEMBLY	1
AU515002004	POW2 & DPA616 – POWER AMPLIFIER BOARD V1.9 – ASSY	
AU516160000	INPUT PCB ASSY	1
AU350000101	BALL BEARING FAN 0.25A 24V DC 80x80x25MM 150MM CABLE	1
AU780200001	AC POWER SOCKET JR-101-1FS	1
AU060200001	SILVER CAP POWER KNOB DIAMETER 9 mm	1
AU520002011	POW2 – LOUDSPEAKER OUTPUT CABLE – 200 MM – AMP TO I/O BOARD	
AU520002016	POW2 – MUTE CABLE – 400 MM – POWERDSP TO AMP	
AU520002015	POW2 – STEREO SHIELDED SIGNALCABLE – 540 MM – I/O BD TO AMP	
AU520002014	POW2 – STEREO SHIELDED SIGNALCABLE – 500 MM – I/O BD TO AMP	
AU520002013	POW2 – STEREO SHIELDED SIGNALCABLE – 460 MM – I/O BD TO AMP	
AU520002012	POW2 – STEREO SHIELDED SIGNAL CABLE – 420 MM – I/O BD TO AMP	
AU520002017	POW2 – POWER CABLE SET RED/BLACK/YELLOW + FERRITE – 400 MM	
AU895743190	BOX KIT 570X430X190MM (FOAM)	
AU710804301	SIGNAL INPUT 3 POLE CONNECTOR(3.81M), SCREW ON TOP	16
AU710803401	4 POLE CONNECTOR (5.08MM), SCREW ON TOP, STRAIGHT	8

Schematic Diagram

AMP PCB – Amp1

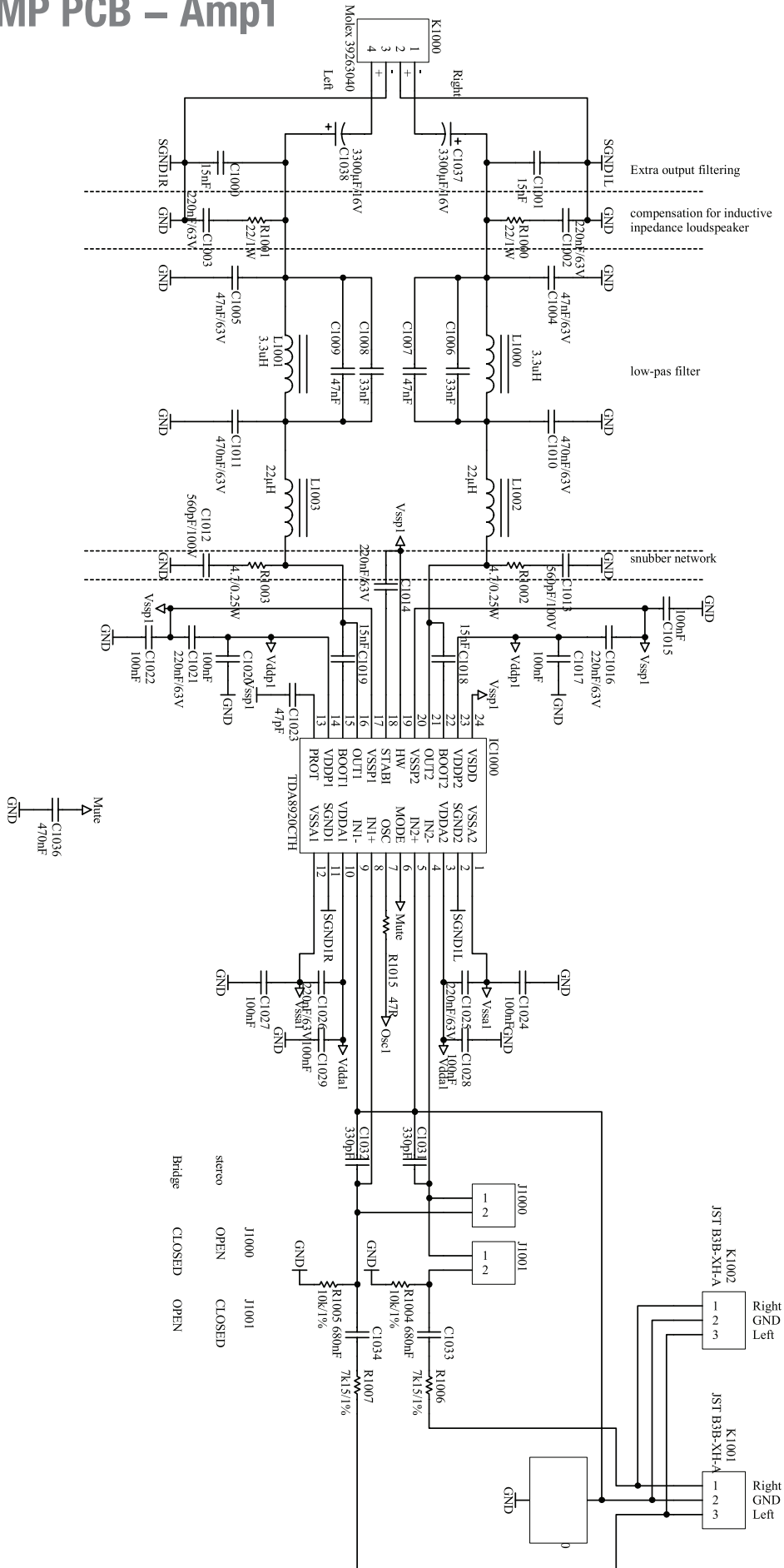

AMP PCB – Fan

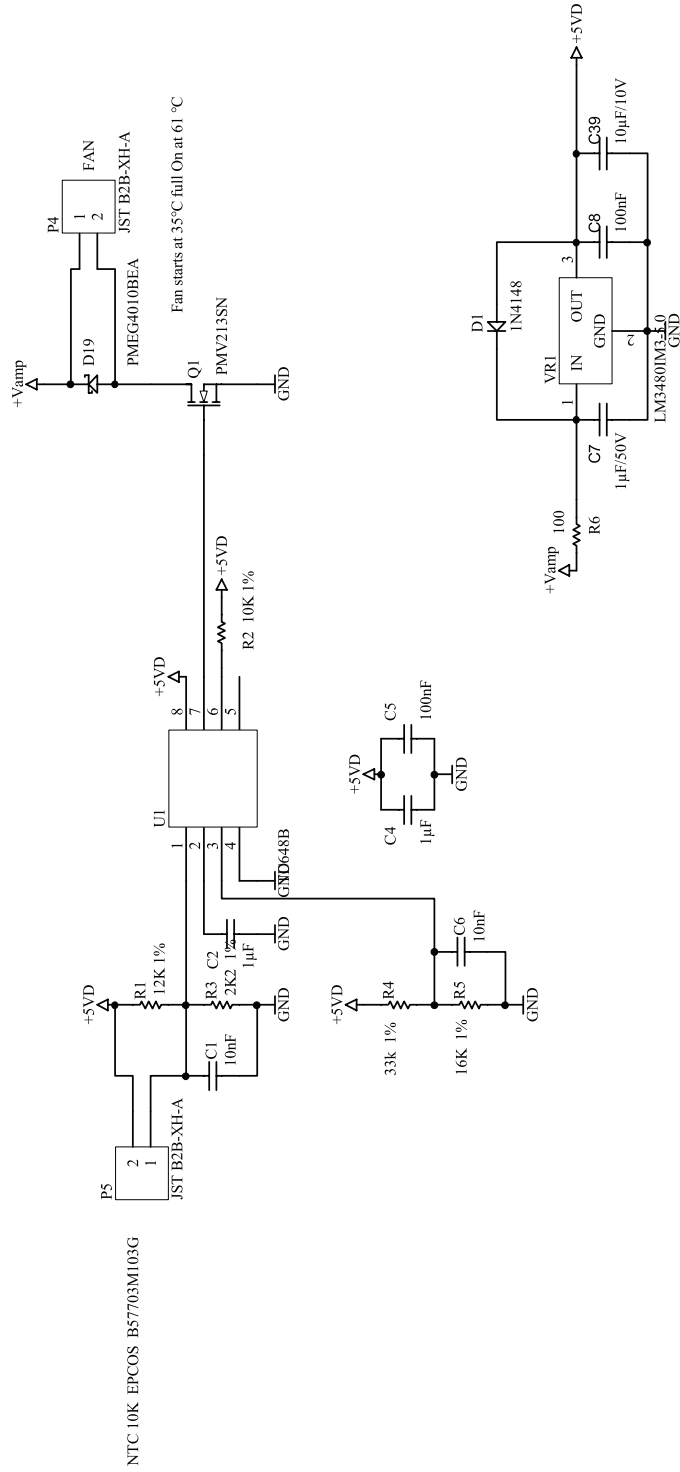

AMP PCB – Power

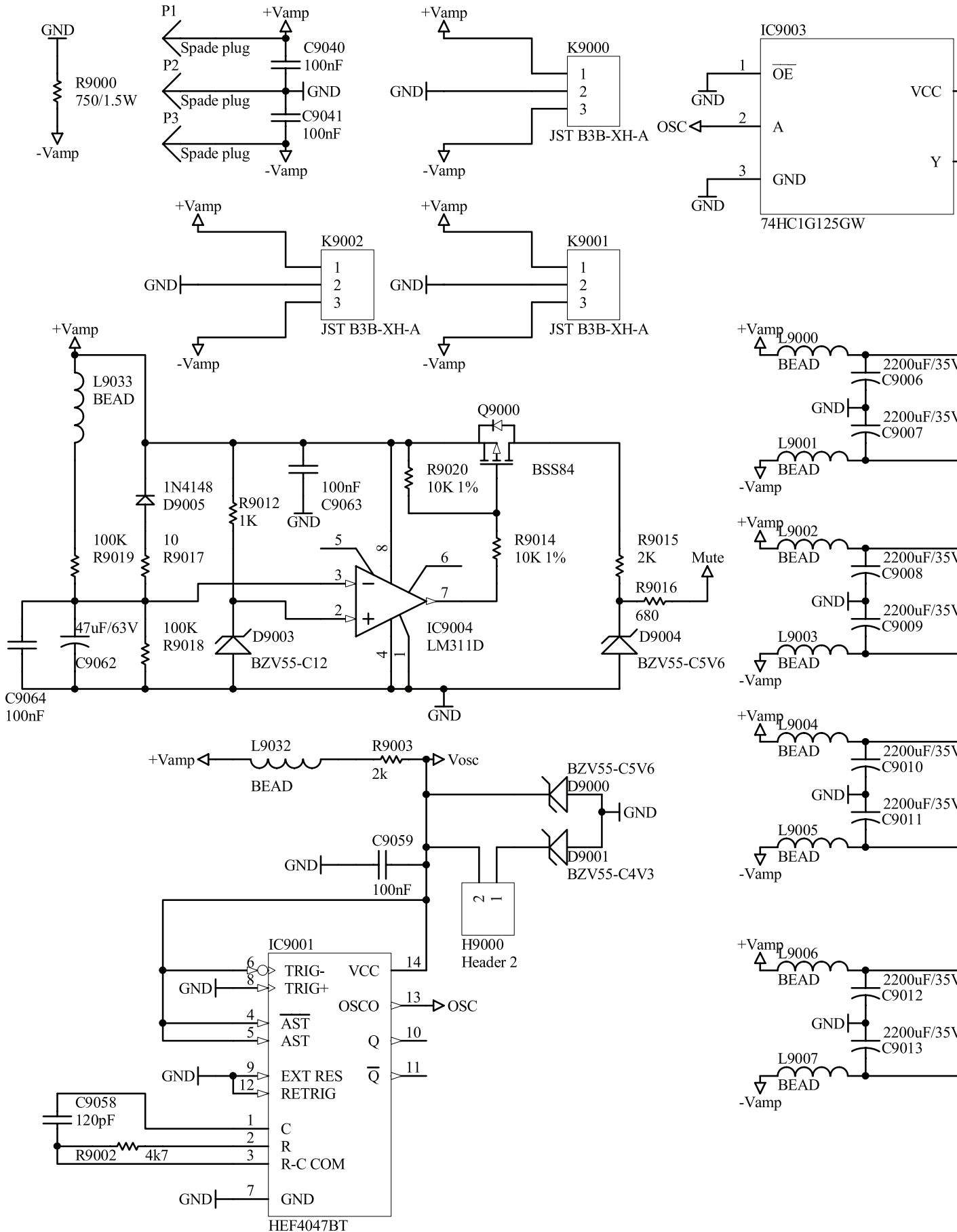

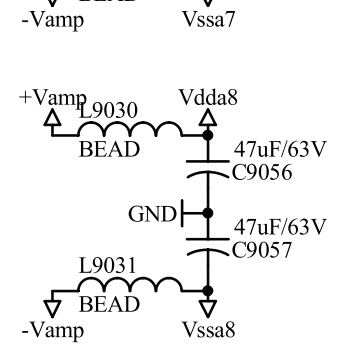
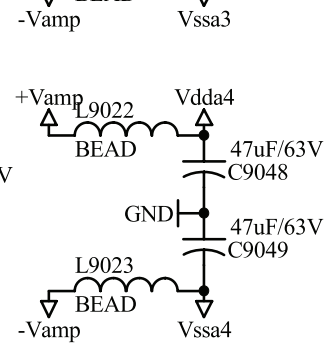
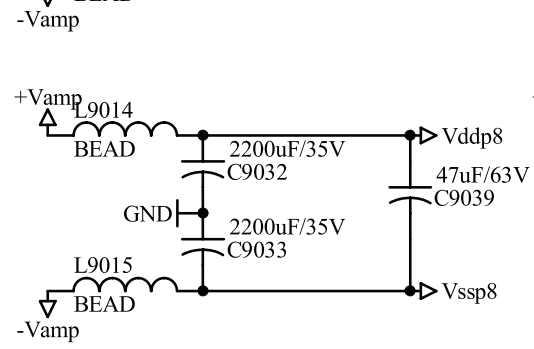
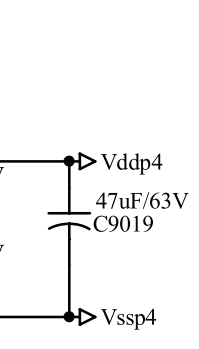
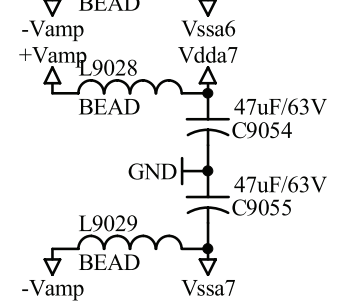
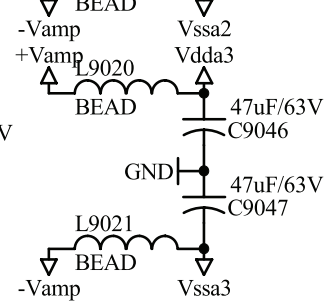
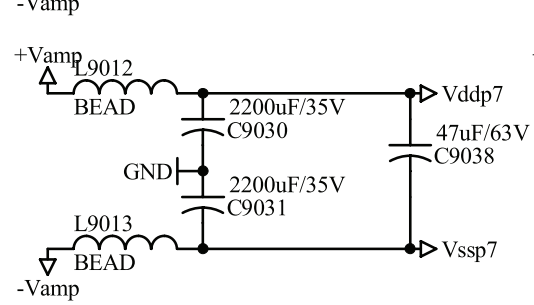
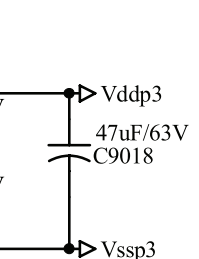
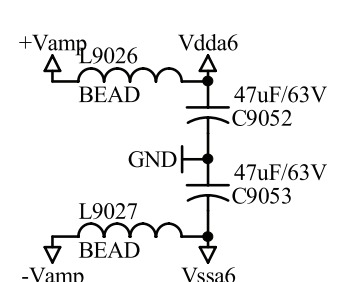
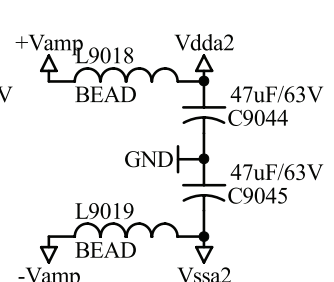
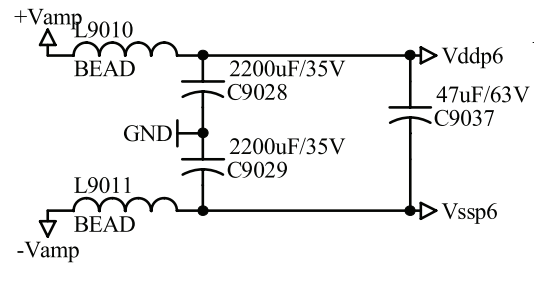
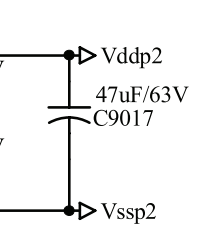
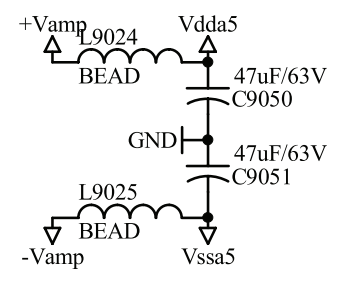
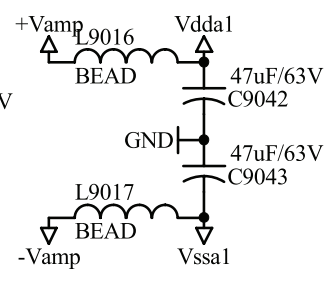
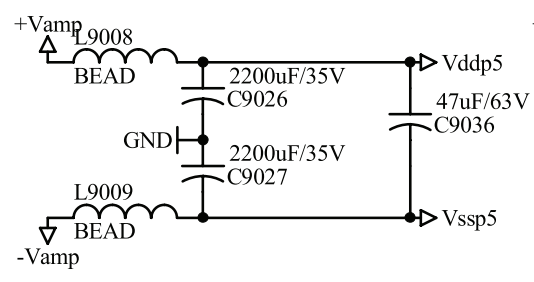
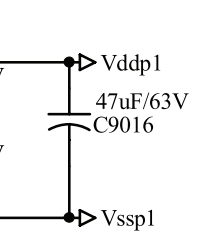
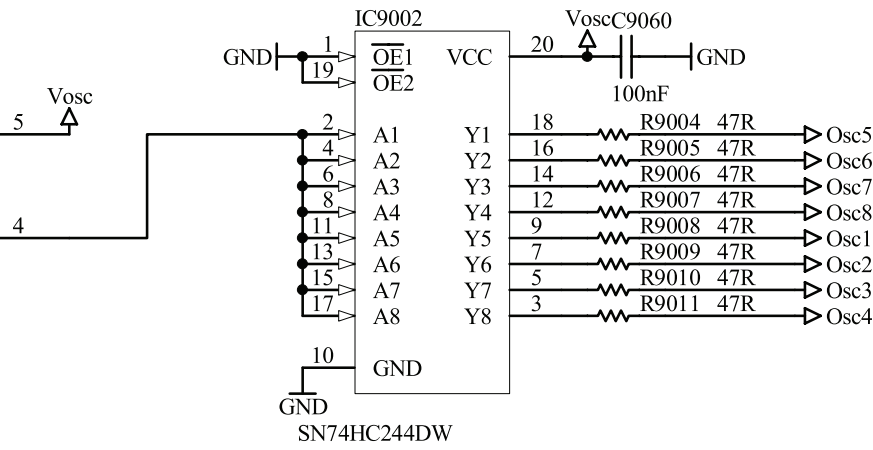

Power Supply – Converter PCB – LLC Converter

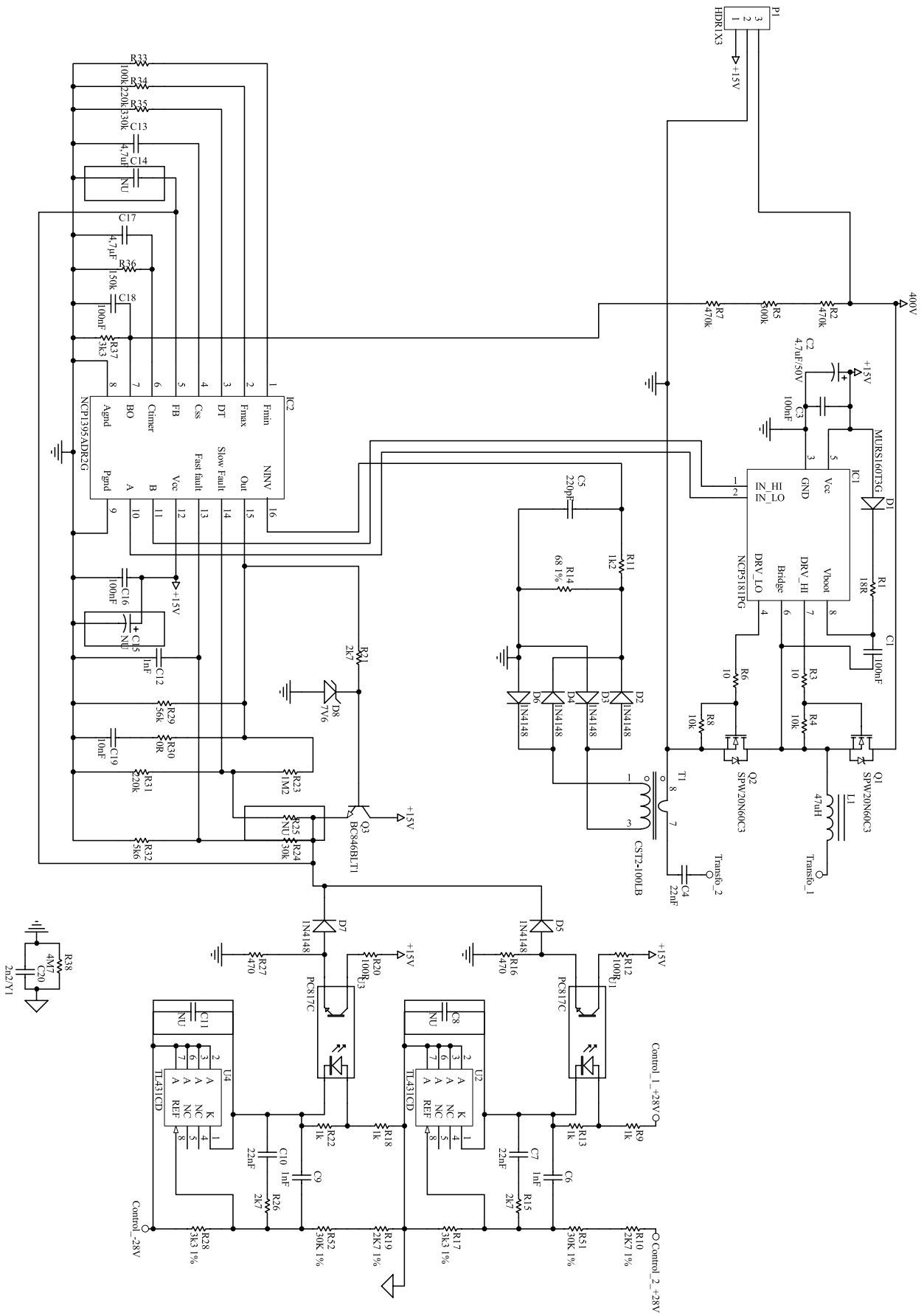

Power Supply – Converter PCB – Output

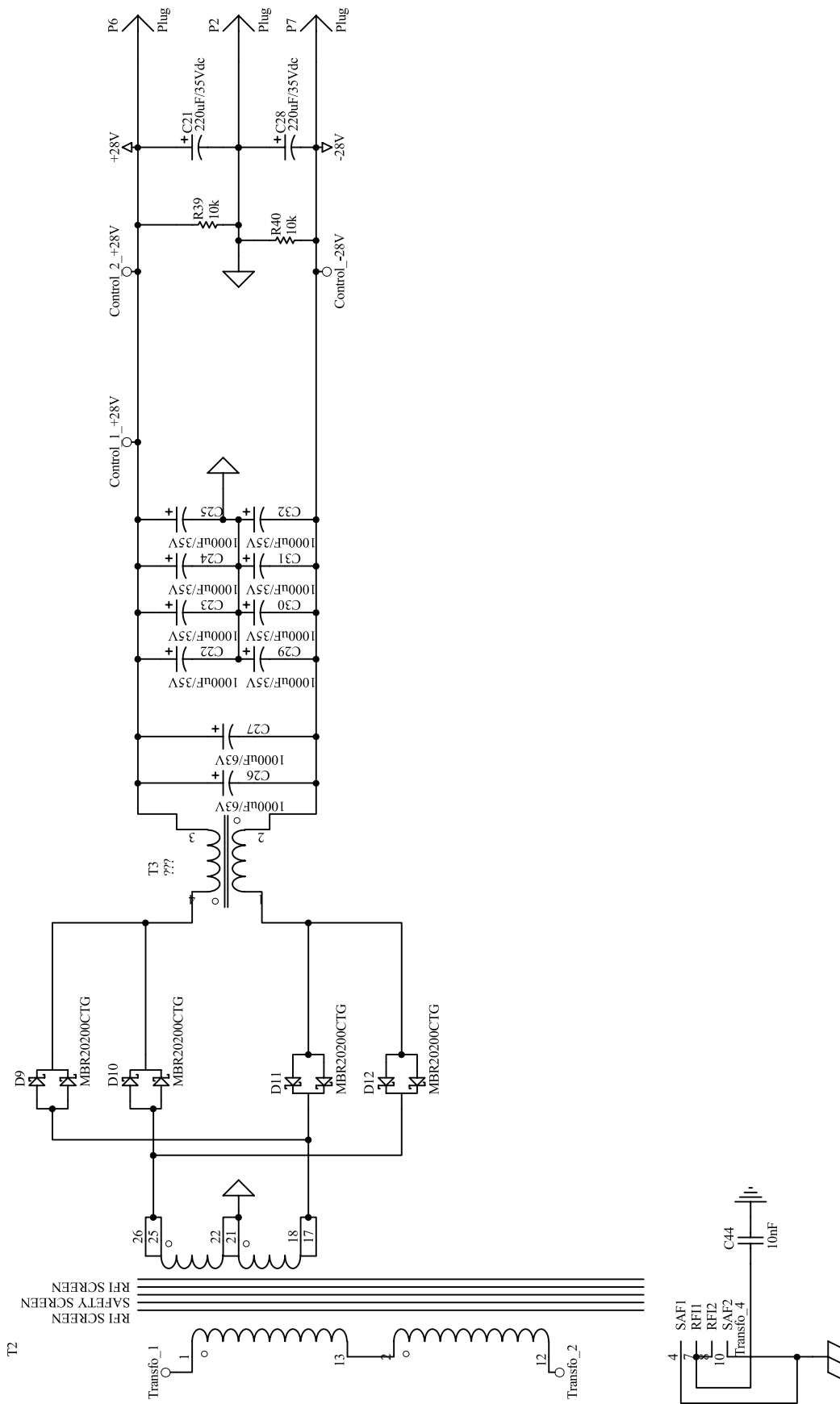

Power Supply – PFC

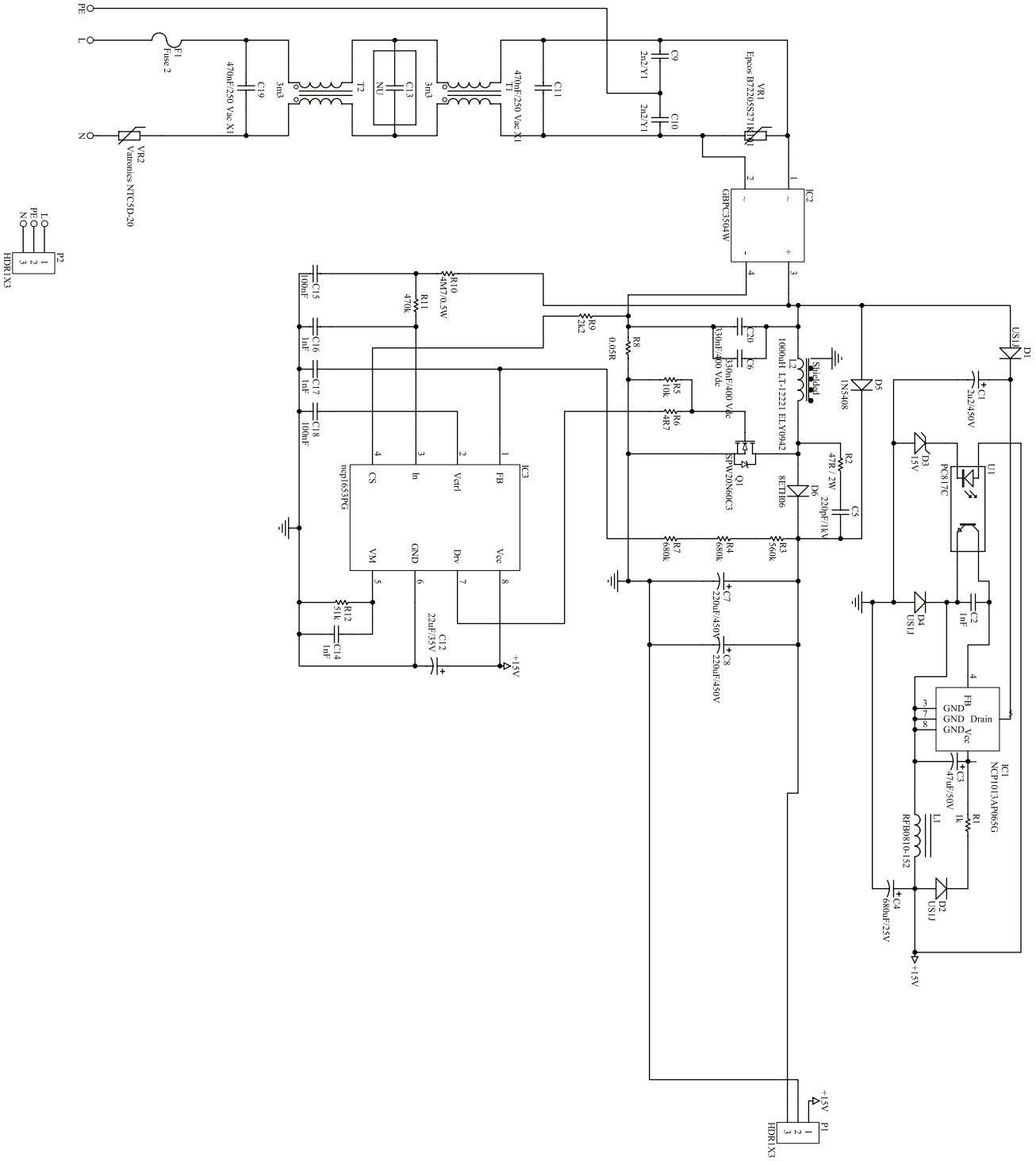

Input – Input 1-2 (x8)

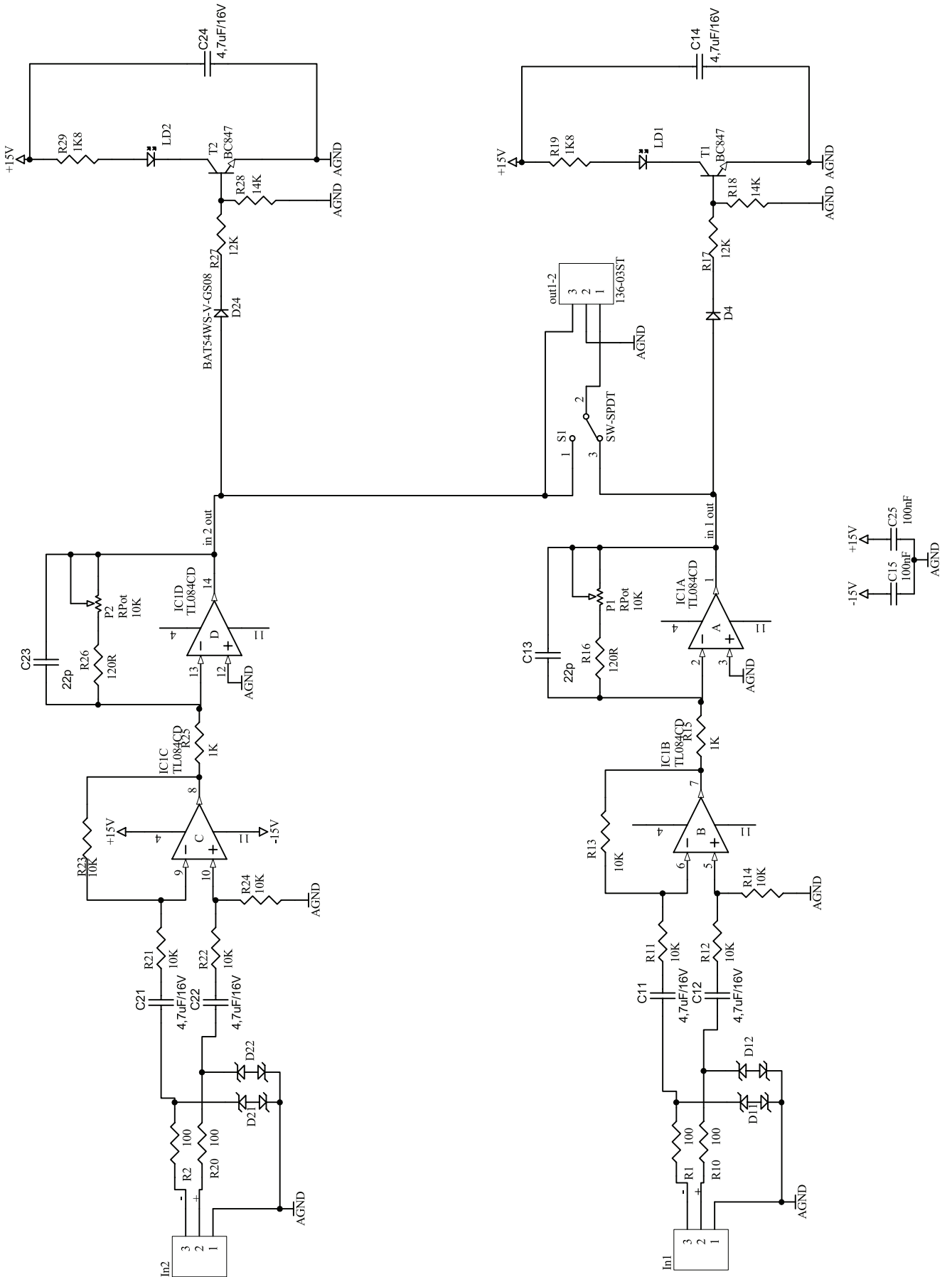

Input – power

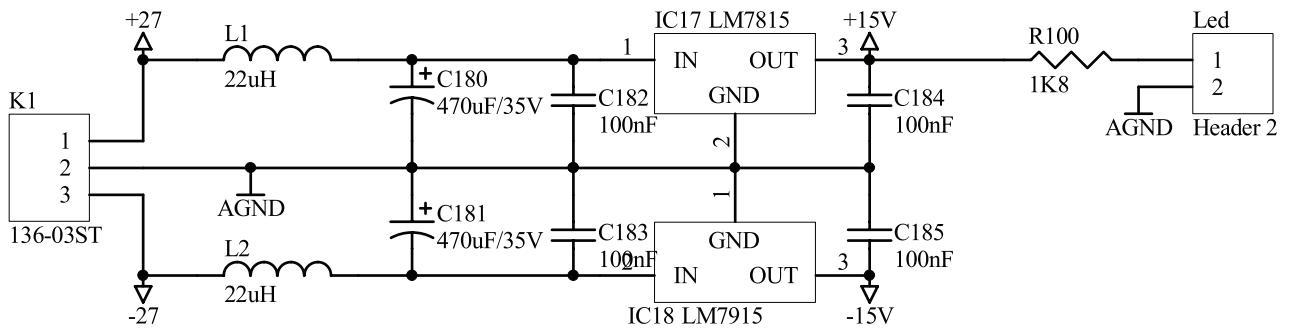

Output PCB

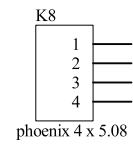
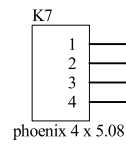
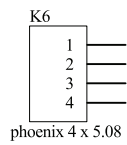
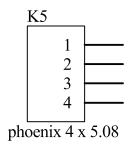
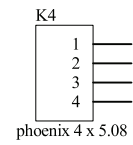
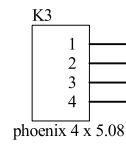
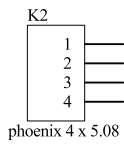
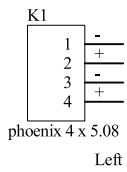

Electrical Parts List

AMP PCB – Amp1 1/3

AUDAC Part code	Value	Description	Designator	Footprint
	74HC1G125GW	3 state buffer	IC9003	SOT353
	BSS84	P-channel Enhancement Mode Vertical D-MOSFET	Q9000	sot-23
	100nF	Capacitor ceramic	C1015, C1017, C1020, C1022, C1024, C1027, C1028, C1029, C2015, C2017, C2020, C2022, C2024, C2027, C2028, C2029, C3015, C3017, C3020, C3022, C3024, C3027, C3028, C3029, C4015, C4017, C4020, C4022, C4024, C4027, C4028, C4029, C5015, C5017, C5020, C5022, C5024, C5027, C5028, C5029, C6015, C6017, C6020, C6022, C6024, C6027, C6028, C6029, C7015, C7017, C7020, C7022, C7024, C7027, C7028, C7029, C8015, C8017, C8020, C8022, C8024, C8027, C8028, C8029	1206
	10nF	Capacitor ceramic	C1, C6	805
	10µF/10V	Capacitor ceramic	C39	805
	15nF	Capacitor ceramic	C1000, C1001, C1018, C1019, C2000, C2001, C2018, C2019, C3000, C3001, C3018, C3019, C4000, C4001, C4018, C4019, C5000, C5001, C5018, C5019, C6000, C6001, C6018, C6019, C7000, C7001, C7018, C7019, C8000, C8001, C8018, C8019	805
	1µF	Capacitor ceramic	C2, C4	805
	1µF/50V	Capacitor ceramic	C7	805
	220nF/63V	Capacitor ceramic	C1002, C1003, C1014, C1025, C1026, C2002, C2003, C2014, C2025, C2026, C3002, C3003, C3014, C3025, C3026, C4002, C4003, C4014, C4025, C4026, C5002, C5003, C5014, C5025, C5026, C6002, C6003, C6014, C6025, C6026, C7002, C7003, C7014, C7025, C7026, C8002, C8003, C8014, C8025, C8026	CR3216-1206
	220nF/63V	Capacitor ceramic	C1016, C1021, C2016, C2021, C3016, C3021, C4016, C4021, C5016, C5021, C6016, C6021, C7016, C7021, C8016, C8021	VP45-3.2
	330pF	Capacitor ceramic	C1031, C1032, C2031, C2032, C3031, C3032, C4031, C4032, C5031, C5032, C6031, C6032, C7031, C7032, C8031, C8032	805
	33nF	Capacitor ceramic	C1006, C1008, C2006, C2008, C3006, C3008, C4006, C4008, C5006, C5008, C6006, C6008, C7006, C7008, C8006, C8008	805
	470nF	Capacitor ceramic	C1036, C2036, C3036, C4036, C5036, C6036, C7036, C8036	805
	470nF/63V	Capacitor MKT	C1010, C1011, C2010, C2011, C3010, C3011, C4010, C4011, C5010, C5011, C6010, C6011, C7010, C7011, C8010, C8011	CAP MTK
	47nF	Capacitor ceramic	C1007, C1009, C2007, C2009, C3007, C3009, C4007, C4009, C5007, C5009, C6007, C6009, C7007, C7009, C8007, C8009	805
	47nF/63V	Capacitor MKT	C1004, C1005, C2004, C2005, C3004, C3005, C4004, C4005, C5004, C5005, C6004, C6005, C7004, C7005, C8004, C8005	CAP MTK
	47pF	Capacitor ceramic	C1023, C2023, C3023, C4023, C5023, C6023, C7023, C8023	805

AMP PCB – Amp1 2/3

AUDAC Part code	Value	Description	Designator	Footprint
	560pF/100V	Capacitor ceramic	C1012, C1013, C2012, C2013, C3012, C3013, C4012, C4013, C5012, C5013, C6012, C6013, C7012, C7013, C8012, C8013	805
	680nF	Capacitor ceramic	C1033, C1034, C2033, C2034, C3033, C3034, C4033, C4034, C5033, C5034, C6033, C6034, C7033, C7034, C8033, C8034	805
	3300µF/16V	Polarized Capacitor (Axial)	C1037, C1038, C2037, C2038, C3037, C3038, C4037, C4038, C5037, C5038, C6037, C6038, C7037, C7038, C8037, C8038	CAPR 5X13X22
	2200uF/35V	Polarized Capacitor (Axial)	C9006, C9007, C9008, C9009, C9010, C9011, C9012, C9013, C9026, C9027, C9028, C9029, C9030, C9031, C9032, C9033	CAPPR7.5–16x31.5
	47uF/63V	Polarized Capacitor (Axial)	C9016, C9017, C9018, C9019, C9036, C9037, C9038, C9039, C9042, C9043, C9044, C9045, C9046, C9047, C9048, C9049, C9050, C9051, C9052, C9053, C9054, C9055, C9056, C9057, C9062	CAPPR2.5–6.3x15
	100nF	Capacitor ceramic	C5, C8, C9040, C9041, C9059, C9060, C9063, C9064	805
	120pF	Capacitor ceramic	C9058	805
	BZV55–C12	Zener Diode 12V	D9003	sod80c
	BZV55–C4V3	Zener Diode 4V3	D9001	SOD80C
	BZV55–C5V6	Zener Diode 5V6	D9000, D9004	SOD80C
	1N4148	Diode	D1, D9005	SOD80C
	PMEG4010BEA	Diode Schottky	D19	sod323
	HEF4047BT	Low–Power Monosta–ble/Astable Multivi–brator	IC9001	S014
	Header 2	Header, 2–Pin	H9000, J1000, J1001, J2000, J2001, J3000, J3001, J4000, J4001, J5000, J5001, J6000, J6001, J7000, J7001, J8000, J8001	HDR1X2
	JST B2B–XH–A	Header, 2–Pin	P4, P5	CN2–2.54
	Molex 39263040	Header, 4–Pin	K1000, K2000, K3000, K4000, K5000, K6000, K7000, K8000	Edge Connector
	BEAD	Inductor	L9000, L9001, L9002, L9003, L9004, L9005, L9006, L9007, L9008, L9009, L9010, L9011, L9012, L9013, L9014, L9015, L9016, L9017, L9018, L9019, L9020, L9021, L9022, L9023, L9024, L9025, L9026, L9027, L9028, L9029, L9030, L9031, L9032, L9033	BLM
AU300002002	22µH	Magnetic–Core Inductor	L1002, L1003, L2002, L2003, L3002, L3003, L4002, L4003, L5002, L5003, L6002, L6003, L7002, L7003, L8002, L8003	Coil 16rhbp
	3.3uH	Magnetic–Core Inductor	L1000, L1001, L2000, L2001, L3000, L3001, L4000, L4001, L5000, L5001, L6000, L6001, L7000, L7001, L8000, L8001	Coil B82477
	LM311D	Voltage Comparator	IC9004	SOIC8
	LM3480IM3–5.0	Series 3–Terminal Positive Regulator	VR1	sot23
	JST B3B–XH–A	Header, 3–Pin	K1001, K1002, K2001, K2002, K3001, K3002, K4001, K4002, K5001, K5002, K6001, K6002, K7001, K7002, K8001, K8002, K9000, K9001, K9002	CN3–2.54
	PMV213SN	N–Channel MOSFET	Q1	SOT23A
	Spade plug	Plug	P1, P2, P3	Power pin
	10	Resistor	R9017	805

AMP PCB – Amp1 3/3

AUDAC Part code	Value	Description	Designator	Footprint
	100K	Resistor	R9018, R9019	805
	750/1.5W	Resistor	R9000	6332[2512]
	0R	Resistor	R1010, R2010, R3010, R4010, R5010, R6010, R7010, R8010	805
	100	Resistor	R6	1206
	10k/1%	Resistor	R2, R9014, R9020, R1004, R1005, R2004, R2005, R3004, R3005, R4004, R4005, R5004, R5005, R6004, R6005, R7004, R7005, R8004, R8005	805
	12K 1%	Resistor	R1	805
	16K 1%	Resistor	R5	805
	22/1W	Resistor	R1000, R1001, R2000, R2001, R3000, R3001, R4000, R4001, R5000, R5001, R6000, R6001, R7000, R7001, R8000, R8001	CR6332–2512
	2K2 1%	Resistor	R3	805
	33k 1%	Resistor	R4	805
	4.7/0.25W	Resistor	R1002, R1003, R2002, R2003, R3002, R3003, R4002, R4003, R5002, R5003, R6002, R6003, R7002, R7003, R8002, R8003	CR3216–1206
	7k15/1%	Resistor	R1006, R1007, R2006, R2007, R3006, R3007, R4006, R4007, R5006, R5007, R6006, R6007, R7006, R7007, R8006, R8007	805
	47R	Resistor	R1015, R2015, R3015, R4015, R5015, R6015, R7015, R8015, R9004, R9005, R9006, R9007, R9008, R9009, R9010, R9011	805
	1K	Resistor	R9012	805
	2k	Resistor	R9003, R9015	805
	4k7	Resistor	R9002	805
	680	Resistor	R9016	805
	SN74HC244DW	Octal Buffer and Line Driver with 3–State Outputs	IC9002	DW020
	TC648B	Fan Controller	U1	S08
AU364128920	TDA8920CTH	100W Class D Amplifier	IC1000, IC2000, IC3000, IC4000, IC5000, IC6000, IC7000, IC8000	HSOP24

Input PCB 1/2

AUDAC Part code	Value	Description	Designator	Footprint
		Led	LD1, LD2, LD3, LD4, LD5, LD6, LD7, LD8, LD9, LD10, LD11, LD12, LD13, LD14, LD15, LD16	LED3MM
	1K	Resistor	R15, R25, R35, R45, R55, R65, R75, R85, R95, R105, R115, R125, R135, R145, R155, R165	0805 – duplicate
	1K8	Resistor	R19, R29, R39, R49, R59, R69, R79, R89, R99, R100, R109, R119, R129, R139, R149, R159, R169	0805 – duplicate
	4,7uF/16V		C11, C12, C14, C21, C22, C24, C31, C32, C34, C41, C42, C44, C51, C52, C54, C61, C62, C64, C71, C72, C74, C81, C82, C84, C91, C92, C94, C101, C102, C104, C111, C112, C114, C121, C122, C124, C131, C132, C134, C141, C142, C144, C151, C152, C154, C161, C162, C164	0805 – duplicate
	10K	Resistor	R11, R12, R13, R14, R21, R22, R23, R24, R31, R32, R33, R34, R41, R42, R43, R44, R51, R52, R53, R54, R61, R62, R63, R64, R71, R72, R73, R74, R81, R82, R83, R84, R91, R92, R93, R94, R101, R102, R103, R104, R111, R112, R113, R114, R121, R122, R123, R124, R131, R132, R133, R134, R141, R142, R143, R144, R151, R152, R153, R154, R161, R162, R163, R164	0805 – duplicate
	12K	Resistor	R17, R27, R37, R47, R57, R67, R77, R87, R97, R107, R117, R127, R137, R147, R157, R167	0805 – duplicate
	14K	Resistor	R18, R28, R38, R48, R58, R68, R78, R88, R98, R108, R118, R128, R138, R148, R158, R168	0805 – duplicate
	22p		C13, C23, C33, C43, C53, C63, C73, C83, C93, C103, C113, C123, C133, C143, C153, C163	0805 – duplicate
	22uH	Inductor	L1, L2	COIL M
	100	Resistor	R1, R2, R3, R4, R5, R6, R7, R8, R9, R10, R20, R30, R40, R50, R60, R70, R80, R90, R1001, R1002, R1101, R1102, R1201, R1202, R1301, R1302, R1401, R1402, R1501, R1502, R1601, R1602	0805 – duplicate
	100nF	Capacitor	C15, C25, C35, C45, C55, C65, C75, C85, C95, C105, C115, C125, C135, C145, C155, C165, C182, C183, C184, C185	0805 – duplicate
	120R	Resistor	R16, R26, R36, R46, R56, R66, R76, R86, R96, R106, R116, R126, R136, R146, R156, R166	0805 – duplicate
	136–03ST	Header, 3–Pin	K1, out1–2, out3–4, out5–6, out7–8, out9–10, out11–12, out13–14, out15–16	CN3–2.54
	470uF/35V	Polarized Capacitor (Radial)	C180, C181	CAPR 5X10X15 (PITCH 5)
	BAT54WS–V–GS08	Diode	D4, D24, D34, D44, D54, D64, D74, D84, D94, D104, D114, D124, D134, D144, D154, D164	SOD323
AU470100847	BC847	NPN High–voltage Transistor	T1, T2, T3, T4, T5, T6, T7, T8, T9, T10, T11, T12, T13, T14, T15, T16	SOT23
	Header 2	Header, 2–Pin	Led	CN2–2.54
	Header 3	Header, 3–Pin	In1a_1, In2, In3, In4, In5, In6, In7, In8, In9, In10, In11, In12, In13, In14, In15, In16	Phoenix 3.81 3
	LM7815	Series 3–Terminal Positive Regulator	IC17	TO–220AB
	LM7915	3–Terminal Negative Regulator	IC18	TO–220AB
	PESD5V0U1BA	Diode	D11, D12, D21, D22, D31, D32, D41, D42, D51, D52, D61, D62, D71, D72, D81, D82, D91, D92, D101, D102, D111, D112, D121, D122, D131, D132, D141, D142, D151, D152, D161, D162	SOD323

Input PCB 2/2

AUDAC Part code	Value	Description	Designator	Footprint
	RPot	Potentiometer	P1_1, P2_1, P3, P4, P5, P6, P7, P8, P9, P10, P11, P12, P13, P14, P15, P16	RK-09K1130A8G
	SW-SPDT	SPDT Subminiature Toggle Switch, Right Angle Mounting, Vertical Actuation	S1_1, S2, S3, S4, S5, S6, S7, S8	SS57010F-0102-LT
	TL084CD	General-Purpose J-FET Quad Operational Amplifier	IC1, IC2, IC3, IC4, IC5, IC6, IC7, IC8	SOic14

Output PCB

AUDAC Part code	Value	Description	Designator	Footprint
	phoenix 4 x 5.08	Header, 4-Pin	K1, K2, K3, K4, K5, K6, K7, K8	4p header 5.08mm

Power Supply – Converter PCB 1/2

AUDAC Part code	Value	Description	Designator	Footprint
	See Output_Inductors.pdf		T3	SPOEL COMMON MODE
	CST2–100LB		T1	CST2
AU360201395	NCP1395ADR2G		IC2	dip16
AU360205181	NCP5181PG		IC1	dip8
	Transfo_4		T2	Transfo ETD59
AU330200001	MURS160T3G	1 Amp Medium Power Silicon Rectifier Diode	D1	sma diode
	100nF	Capacitor	C1	1206
	100nF	Capacitor	C3, C16, C18	805
	10nF	Capacitor	C19, C44	805
	1nF	Capacitor	C6, C9, C12	805
	220pF	Capacitor	C5	805
	22nF/1600V	Capacitor	C4	Cap PP8.5x21.5x30, p=27.5
	22nF	Capacitor	C7, C10	805
	2n2/Y1	Capacitor	C20	Cap Y1
	4,7uF	Capacitor	C13	1206
	4,7µF	Capacitor	C17	1206
	NU	Capacitor, Resistor	C8, C11, C14, R25	805
	HDR1X3	Connector	P1	400V 3pin
AU330200002	MBR20200CTG	Diode	D9, D10, D11, D12	TO–220AB
AU471000846	BC846BLT1	General Purpose Transistor NPN Silicon	Q3	318–08
AU475002060	SPW20N60C3	HEXFET N–Channel Power MOSFET	Q1, Q2	TO–247
	1N4148	High Conductance Fast Diode	D2, D3, D4, D5, D6, D7	sod80c
	PCV–2–473–10L	Magnetic–Core Inductor	L1	Spoel CD technologies 2.4x23.8x24.4
AU362520817	PC817X4J0000F	Optoisolator	U1, U3	dip4
	Plug	Plug	P2, P6, P7	Power pin
	1000uF/35V	Polarized Capacitor (Radial)	C22, C23, C24, C25, C29, C30, C31, C32	CAPPR5–12.5x25
	1000uF/63V	Polarized Capacitor (Radial)	C26, C27	CAPPR7.5–16x35.5
	220uF/35Vdc	Polarized Capacitor (Radial)	C21, C28	CAPPR5–10x12.5
	4.7uF/50V	Polarized Capacitor (Radial)	C2	CAPPR2–5x6.8
	NU	Polarized Capacitor (Radial)	C15	CAPPR2–5x6.8
	TL431CD	Programmable Precision Reference	U2, U4	751–05
	0R	Resistor	R30	805
	10	Resistor	R3, R6	AXIAL–0.3
	100k 1%	Resistor	R33	805
	100R 1%	Resistor	R12, R20	805
	10k	Resistor	R4, R8, R39, R40	1206
	150k 1%	Resistor	R36	805
	18R	Resistor	R1	805
	1k 1%	Resistor	R9, R13, R18, R22	805
	1k2 1%	Resistor	R11	805

Power Supply – Converter PCB 2/2

AUDAC Part code	Value	Description	Designator	Footprint
	1M2 1%	Resistor	R23	805
	220k 1%	Resistor	R31, R34	805
	2K7 1%	Resistor	R10, R15, R19, R21, R26	805
	300k	Resistor	R5	1206
	30k 1%	Resistor	R24, R51, R52	805
	330k 1%	Resistor	R35	805
	3k3 1%	Resistor	R17, R28, R37	805
	470	Resistor	R16, R27	805
	470k	Resistor	R2, R7	1206
	4M7	Resistor	R38	RES MRS25S
	56k	Resistor	R29	805
	5k6 1%	Resistor	R32	805
	68 1%	Resistor	R14	805
	BZV55–C7V5	Zener Diode	D8	sod80c

Power Supply – PFC PCB

AUDAC Part code	Value	Description	Designator	Footprint
AU462802001	PCA EPC3245–15–RC	Inductor 1000µH/4,58A/550W	L2	PFC inductor
	GBPC3504W	Bridge Rectifier 35A/400V	IC2	gelijkrichter
AU366102101	NCP1013AP065G	Self–Supplied monolithic switcher 65KHz/350mA	IC1	dip8
AU366102165	NCP1653PG	PFC Controller	IC3	dip8
	1N5408	3A/1000V Medium Power Silicon Rectifier Diode	D5	D0–201AD
	US1J	1A/600V Medium Power Silicon Rectifier Diode	D1, D2, D4	SMA diode
	100nF	Capacitor	C15, C18	805
	1nF	Capacitor	C2, C14, C16, C17	805
	220pF 1kV	Capacitor	C5	Cap ECK
	2n2/Y1 250V	Capacitor	C9, C10	Cap Y1
	330nF 400 Vdc	Capacitor	C20, C6	Cap polyester 7x12.5x18, p=15
	470nF/X1 250V	Capacitor	C11, C19	Cap X1 15x25x31, p=27.5
	Not used	Capacitor	C13	Cap X1 15x25x31, p=27.5
	HDR1X3	Connector	P1	
	HDR1X3	Connector	P2	
	Fuse 2	Fuse	F1	Fuse
AU472472060	SPW20N60C3	HEXFET N–Channel Power MOSFET 20A/650V	Q1	TO–247
	8ETH06	High Conductance Fast Diode 8A/600V	D6	TO–220ac
	RFB0810–182L	Inductor 1,8mH/0,32A	L1	Spoel ELC09
AU362520817	PC817XJ0000F	Optoisolator	U1	dip4
	220uF 450V Elco	Polarized Capacitor (Radial)	C7, C8	CAPPR 10x30x35
	22uF 35V Elco	Polarized Capacitor (Radial)	C12	CAPPR2–5x6.8
	2u2 450V Elco	Polarized Capacitor (Radial)	C1	CAPPR5–10x12.5
	680uF 25V Elco	Polarized Capacitor (Radial)	C4	CAPPR5–10x16
	47uF 50V Elco	Polarized Capacitor (Radial)	C3	CAPPR2.5–6.3x11.5
	0.05R	Resistor Metal Strip 2W	R8	oars
	10k	Resistor	R5	1206
	1k	Resistor	R1	805
	2k2	Resistor	R9	1206
	470k	Resistor	R11	1206
	47R 2W	Resistor	R2	AXIAL
	4M7 0.5W	Resistor	R10	AXIAL
	4R7	Resistor	R6	805
	51k	Resistor	R12	805
	560k	Resistor	R3	1206
	680k	Resistor	R4, R7	1206
AU300002001	Epcos B82723J2402N1	Surface Mount 1:1 Transformer 2,7mH/4A/250V	T1, T2	
	Epcos B72205S271K101	Varistor (Voltage–Sensitive Resistor)	VR1	Radial
	NTC Rhopoint SG170	Varistor (Voltage–Sensitive Resistor)	VR2	Radial
	BZV55–C15	Zener Diode 15V	D3	sod80c
	Heatsink	Heatsink		

Printed Circuit Board Diagram

Amp PCB

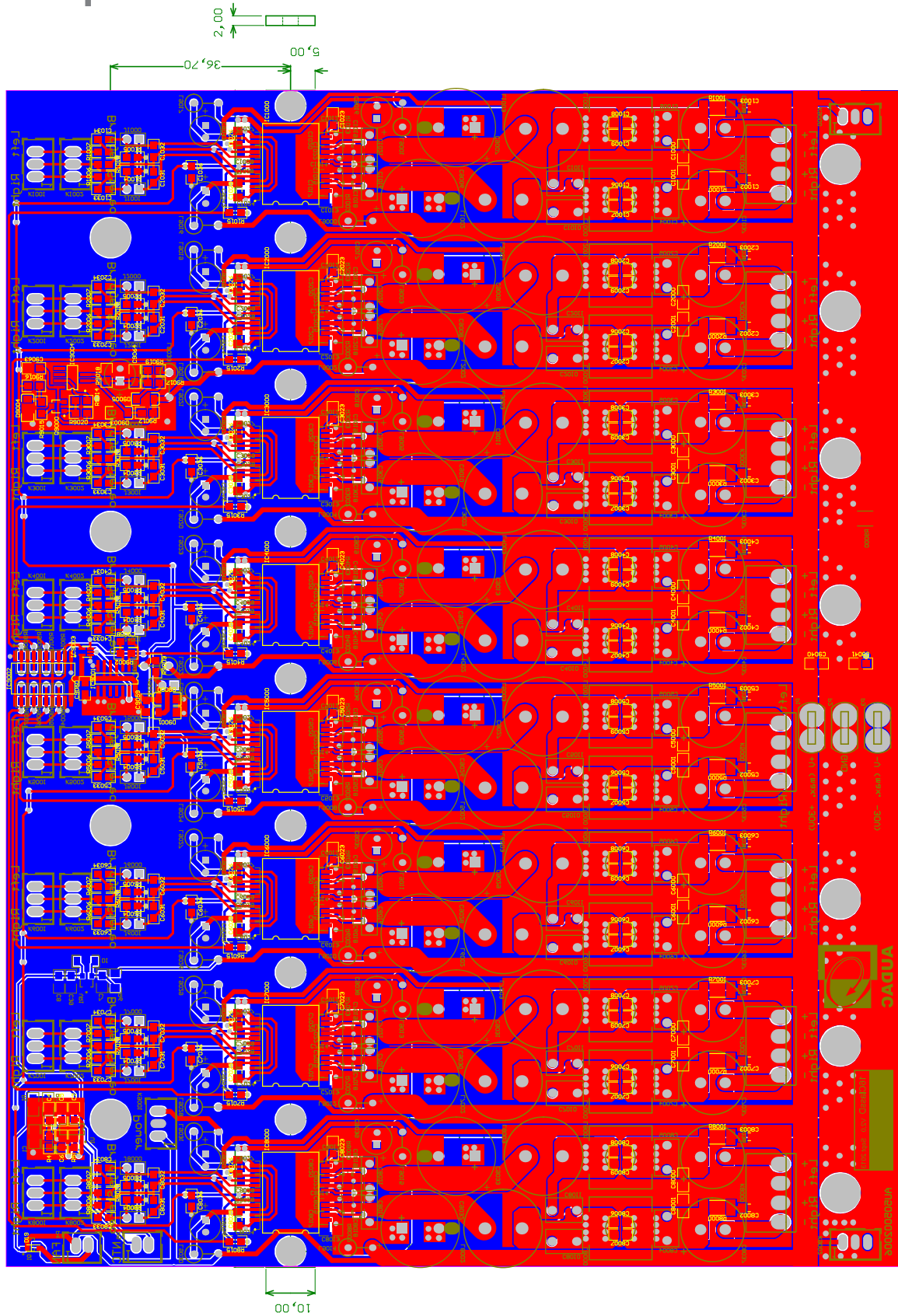

Input PCB

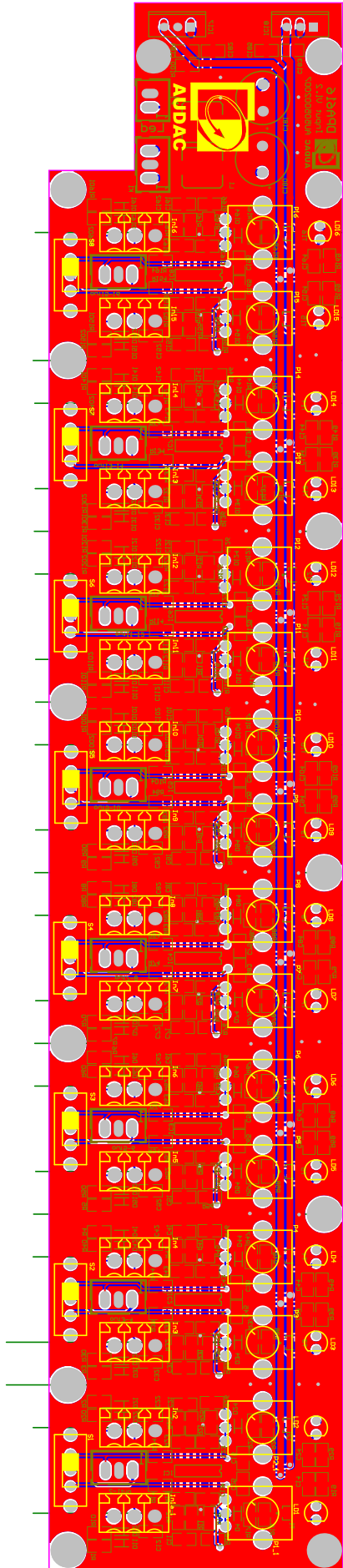

Output PCB

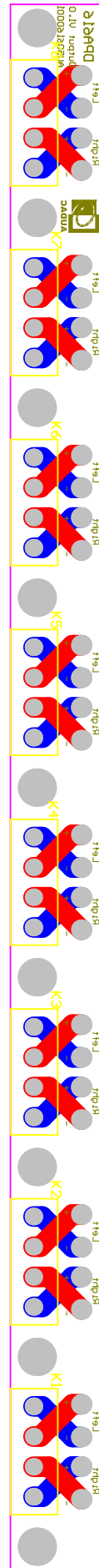

Power supply – Converter PCB

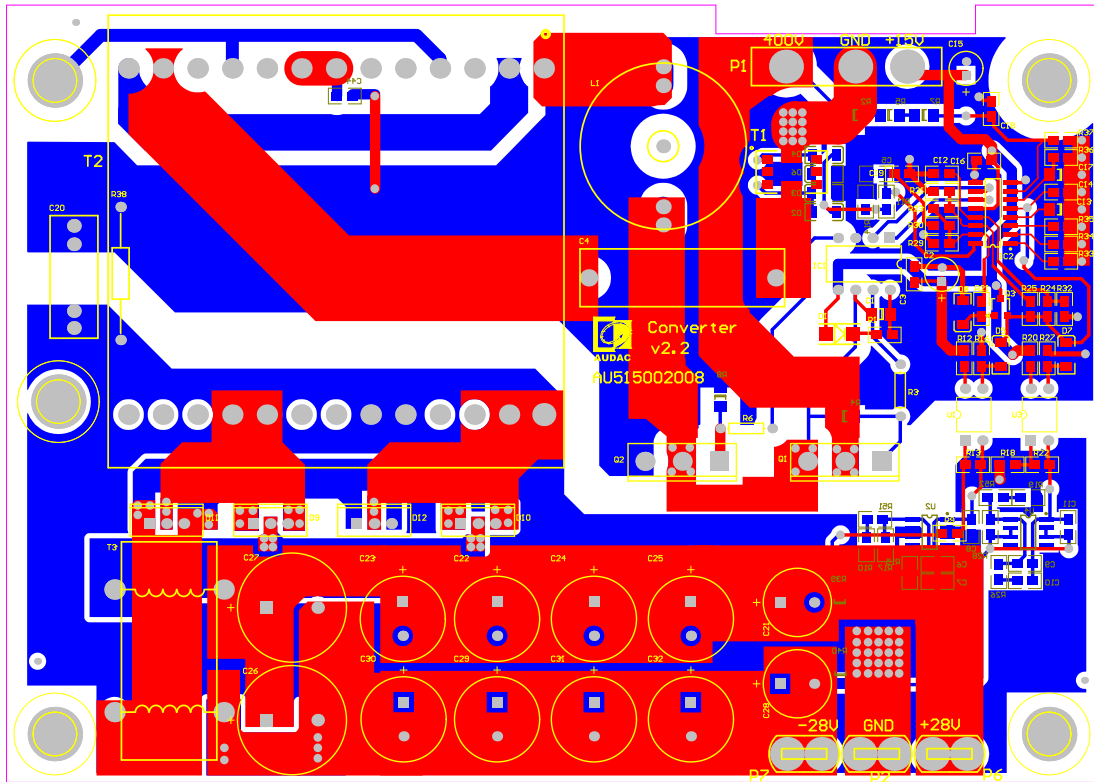

Power supply – PFC PCB

