

NOTES: UNLESS OTHERWISE SPECIFIED

1: ALL RESISTORS ARE OHMS

2:  = LOW VOLTAGE GROUND

3:  = HIGH VOLTAGE GROUND

4: * = TRANSFORMER TAP
 GREEN FOR SPECTRA 4400
 WHITE FOR SPECTRA 6600
 BLUE/YELLOW = SEE OWNERS MANUAL

MK-2146 MAGNE-KINETIC INTERFACE FOR SPECTRA 4400/6600

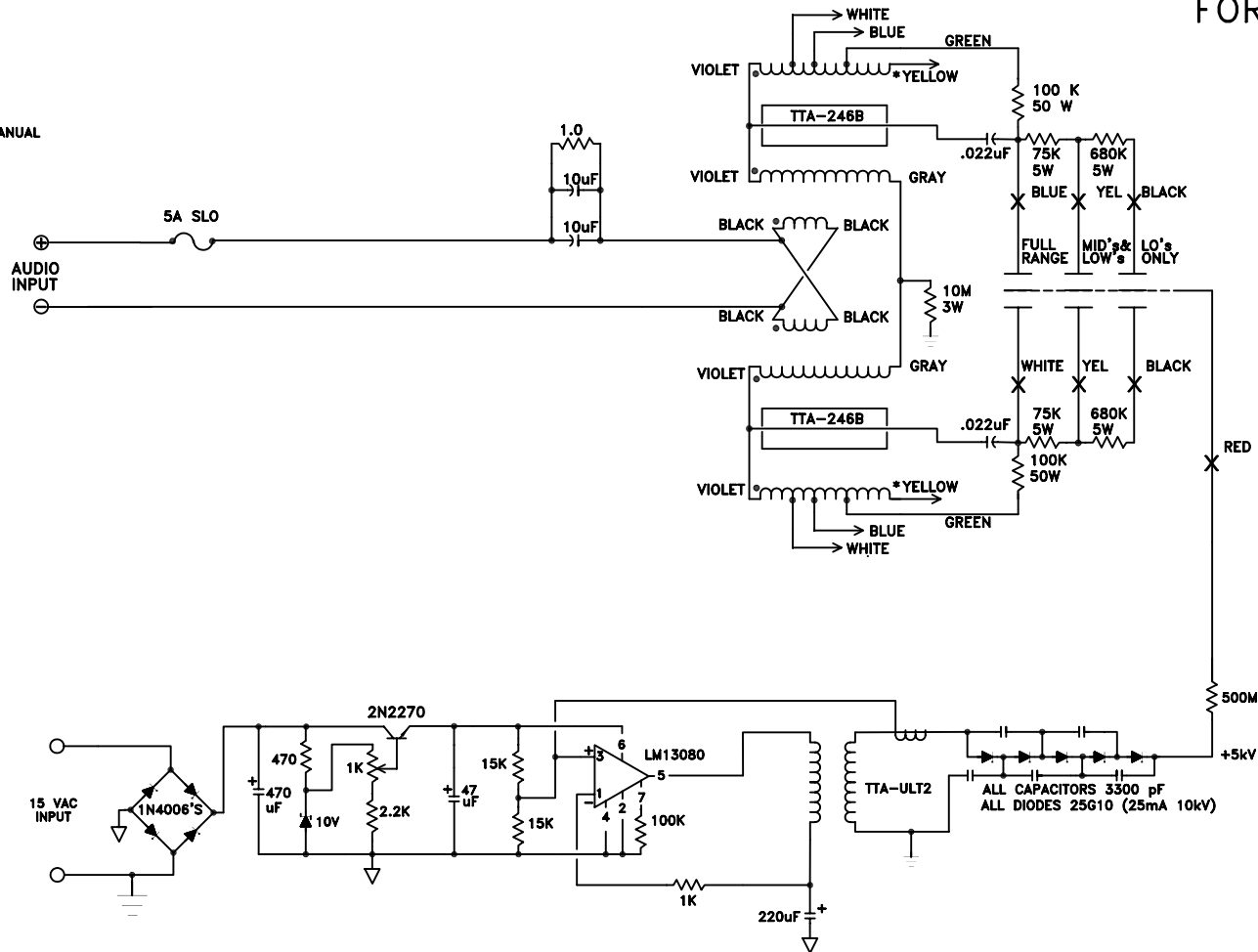

REVISIONS:

1. 5/29/91: UPDATED BIAS SUPPLY

ACOUSTAT
 A DIVISION OF ROCKFORD CORP.
 TEMPE, AZ., 85281, USA

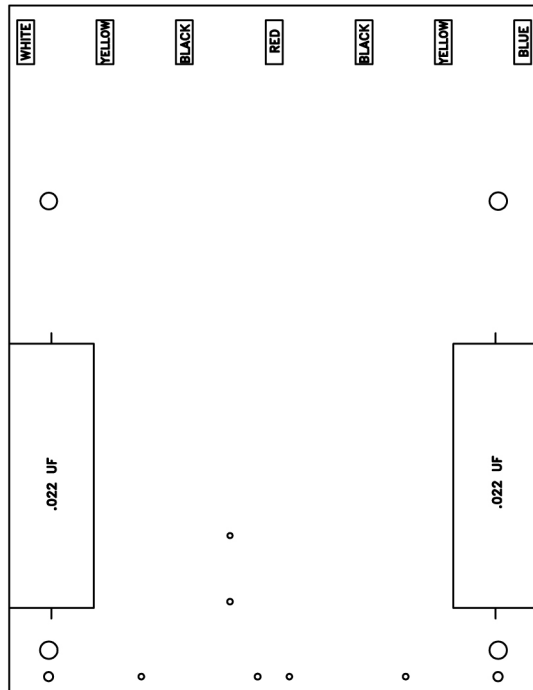

SOLDER SIDE

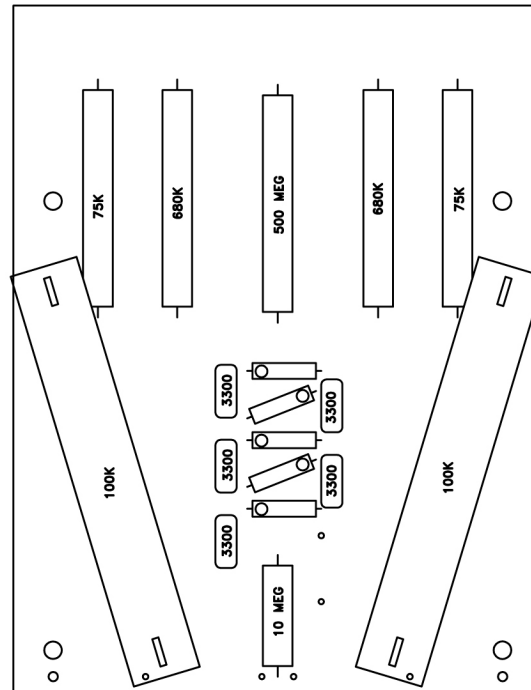

COMPONENT SIDE

ACOUSTAT
A DIVISION OF ROCKFORD CORPORATION

4400/6600 PC LAYOUT

ANY TECHNICAL QUESTIONS REGARDING
THIS PRINT SHOULD BE REFERRED TO
ANDY SZABO (602)967-3565 EXT. 3036

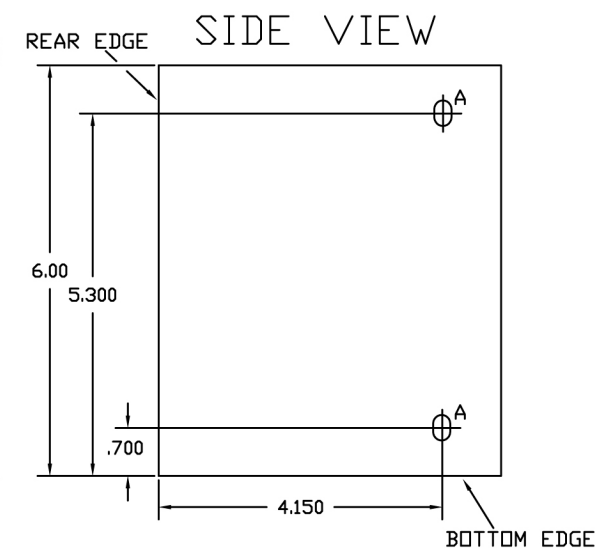
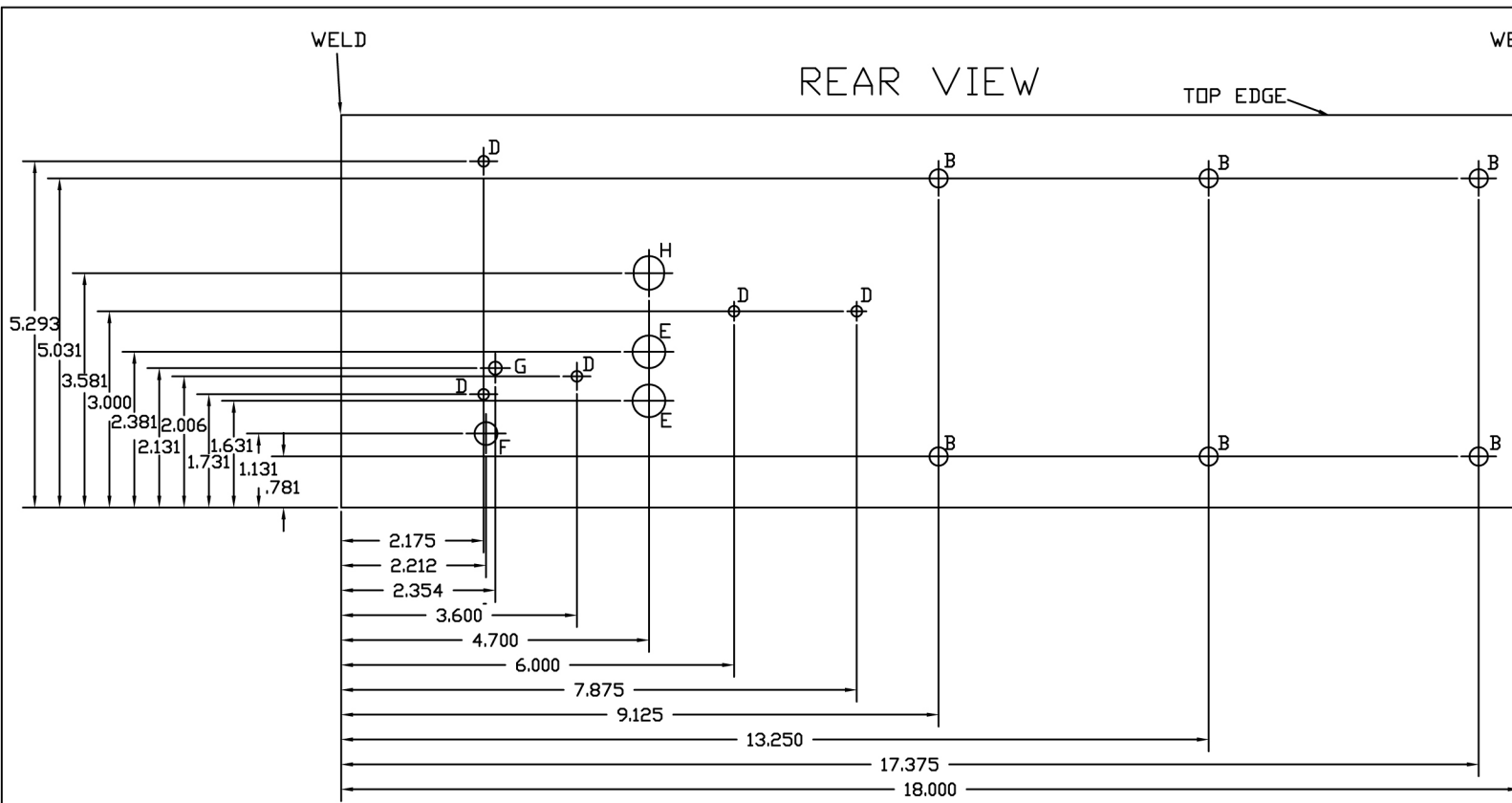

A	.250 x .375 OBR	4
B	.281	6
D	.166	5
E	.500	2
F	.350	1
G	.199	1
H	.506 x .465 'DD'	1

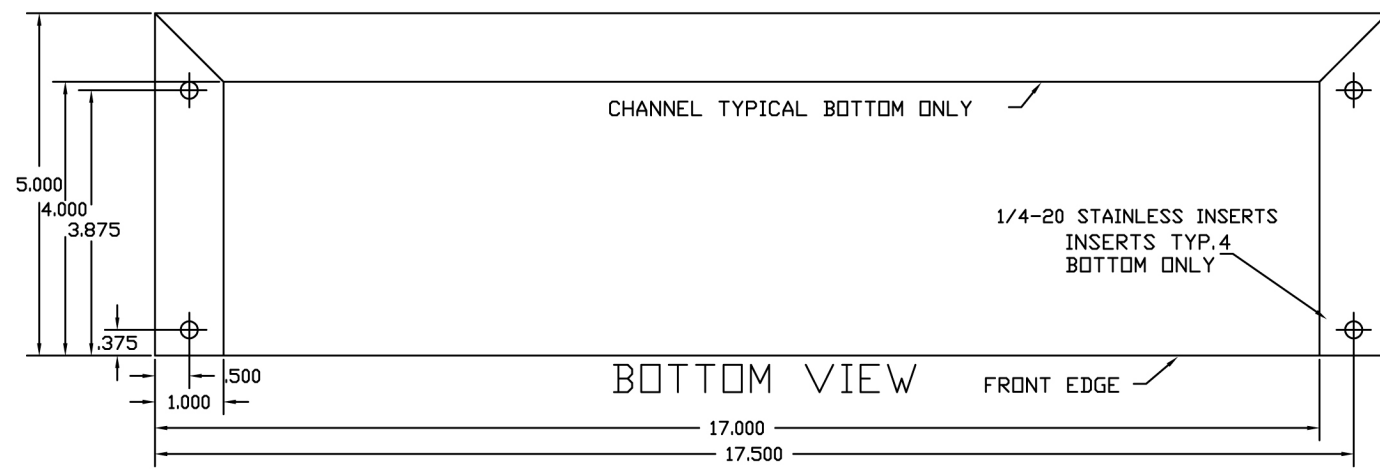

- NOTES:
- 1: SIDE VIEW IS TYPICAL
 - 2: FRONT, TOP, AND SIDES TO BE FREE OF SCRATCHES, GOUGES, ETC . . .
 - 3: ALL CORNERS TO BE BROKEN, ALL EDGES DEBURRED
 - 4: SEAMS TO BE WELDED AND GROUND TO RADIUS SUITABLE FOR PAINTING
 - 5: ALL DIMENSIONS ARE INCHES

ACOUSTAT
A DIVISION OF ROCKFORD CORP
SPECTRA 44/66 INTERFACE CHASSIS

NOTES:

1. ALL DIMENSIONS ARE INCHES
2. MATERIAL... 1" MDF: SIDES, VERTICAL SUPPORTS, BLOCKS
 3/4" MDF: BACK, TOP, CROSSMEMBER
 1/2" 9-PLY: BOTTOM
 1/4" LUAN: PANEL FLANGES
 ALDER: SIDE MOUNTS

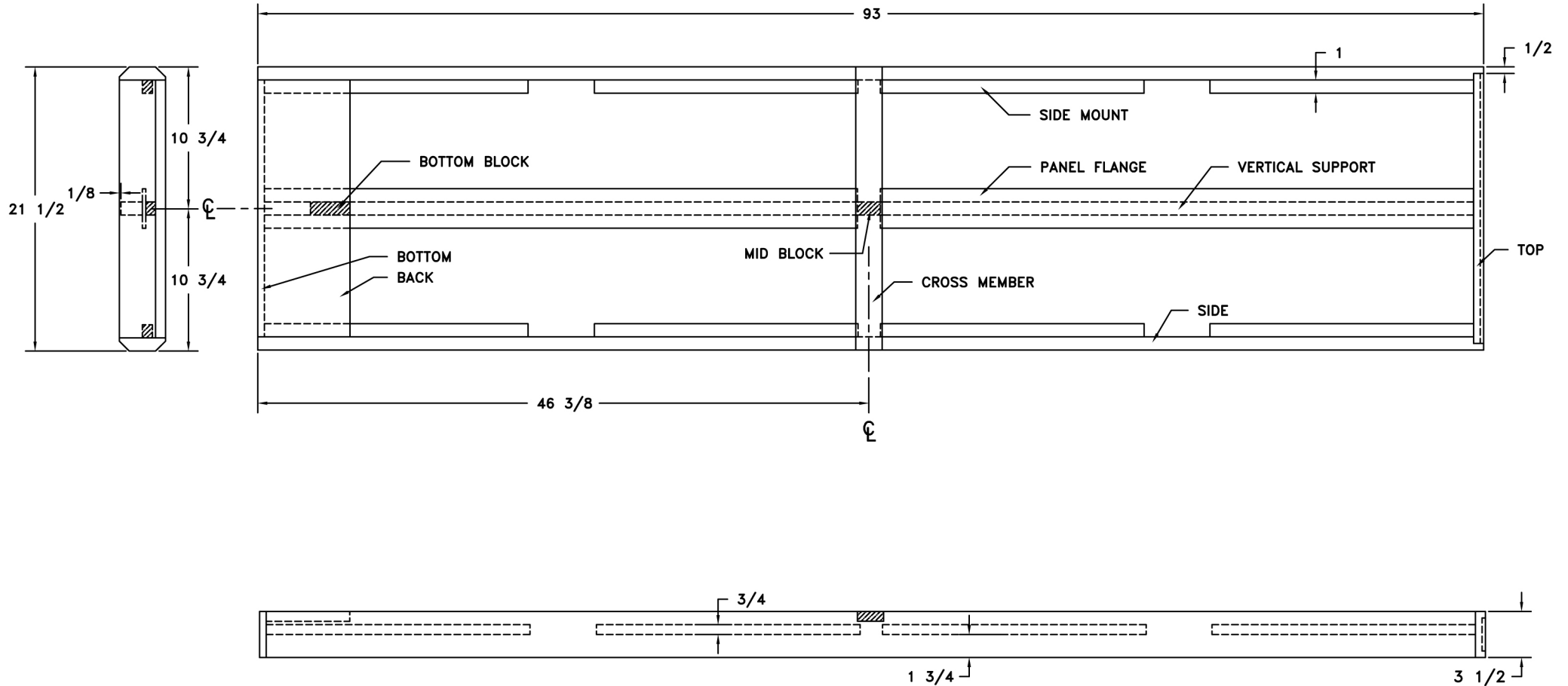

PART	QUANTITY	DIMENSIONS	COMMENTS
TOP	1	20 1/2 x 3 1/2 x 3/4	SEE DETAIL
SIDE	2	93 x 3 1/2 x 1	SEE DETAIL
BOTTOM	1	19 1/2 x 2 3/4 x 1/2	
BACK	1	19 1/2 x 7 x 3/4	SEE DETAIL
CROSSMEMBER	1	21 1/2 x 2 x 3/4	
MID BLOCKS	1	1 1/2 x 1 x 1	
BOTTOM BLOCKS	1	3 x 1 x 3/4	
PANEL FLANGES	2	3 x 45 x 1/4	W/T-NUTS
SIDE MOUNTS	8	1 x 3/4 x 20	
VERTICAL SUPPORT	1	91 3/4 x 1 5/8 x 1	

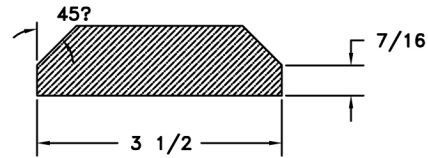

SIDE: CROSS SECTION
SCALE: FULL

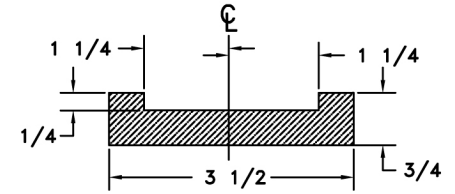

TOP: CROSS SECTION
SCALE: FULL

SIDE DETAIL
SCALE: 1/3

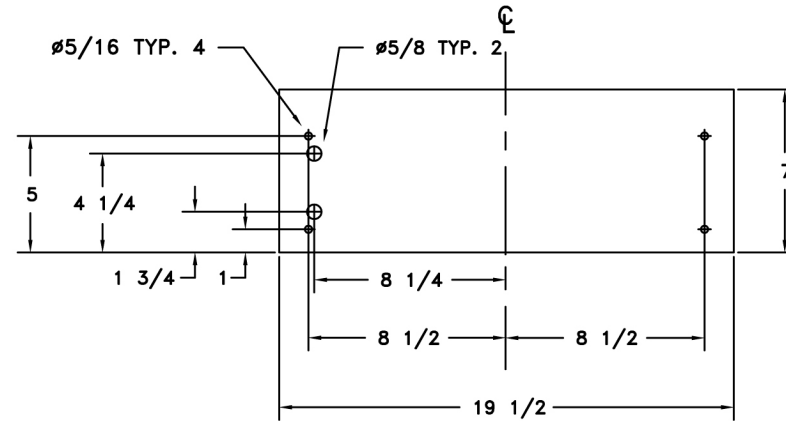
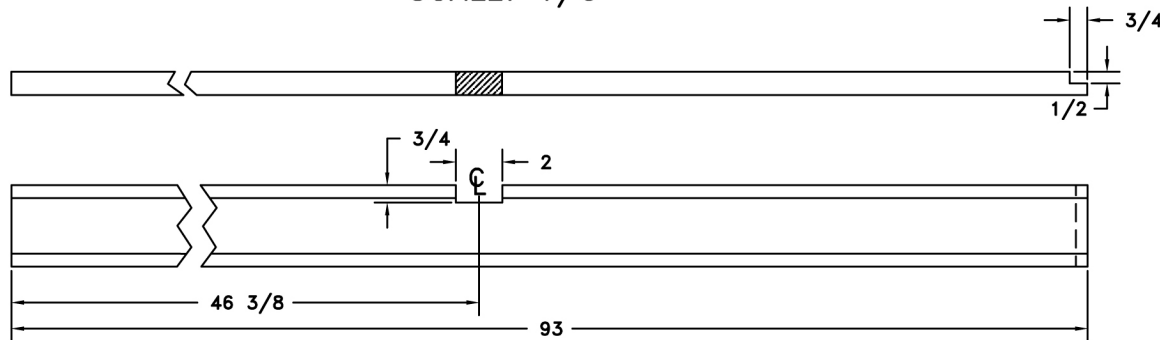

BACK DETAIL
SCALE: 1/3

INSTALL 1/4"-20 X 9/16" 6-PRONG T-NUTS
FROM INSIDE OF 5/16" HOLES

NOTES:

1. ALL DIMENSIONS INCHES
2. MATERIAL: OAK VENEER PARTICLE BOARD
SOLID OAK BANDING, VARIOUS FINISHES
3. PART NUMBER SUFFIX:
X= BSD- DARK OAK
BSL- LIGHT OAK
BSBL- BLACK OAK

REVISIONS:

6/12/90 CHANGED 14 DEPTH TO 17
ADDED LOGO POSITION

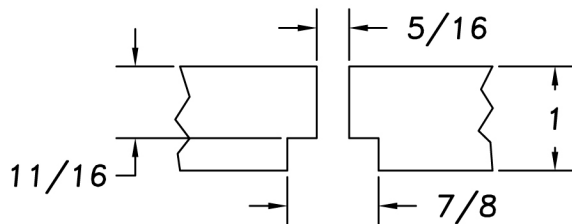
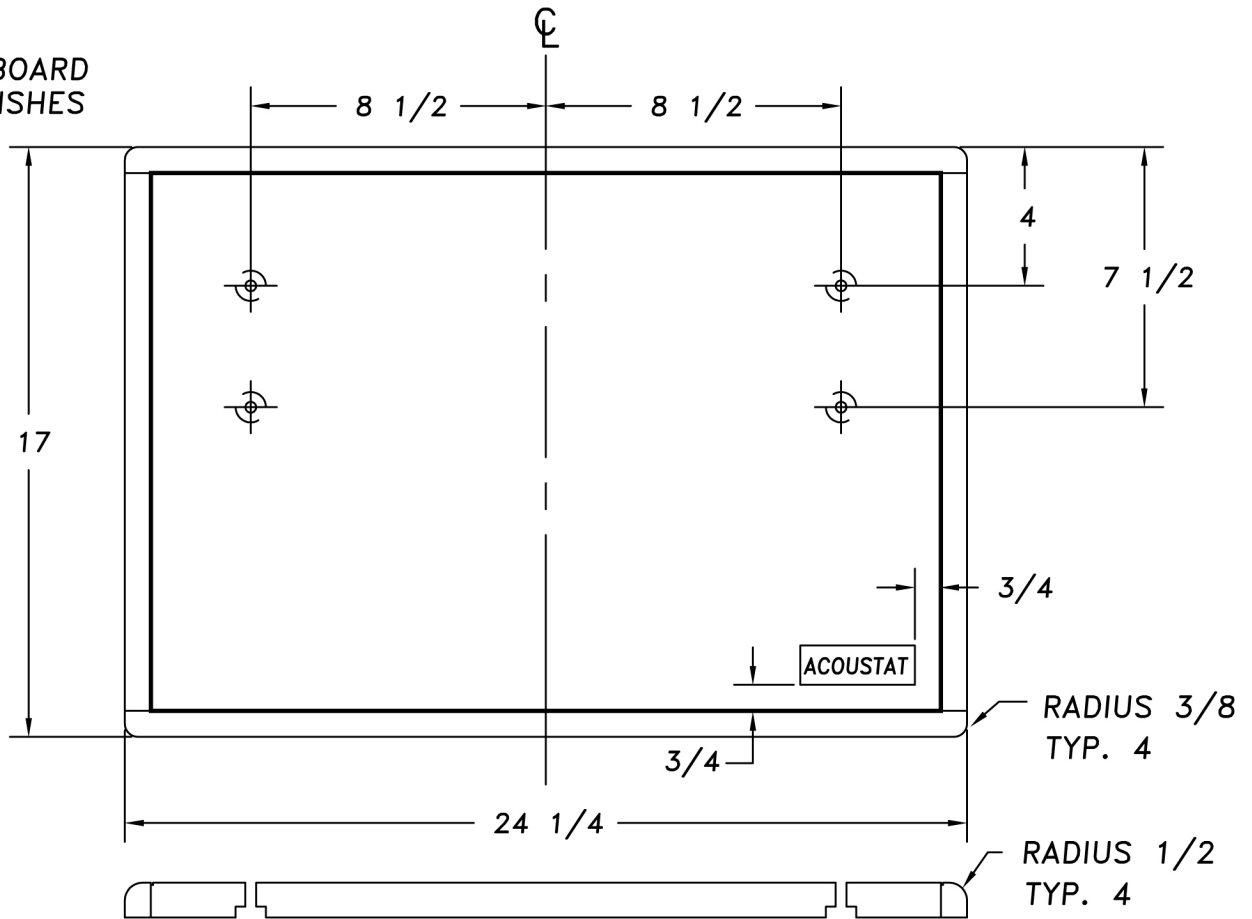

COUNTERBORE DETAIL

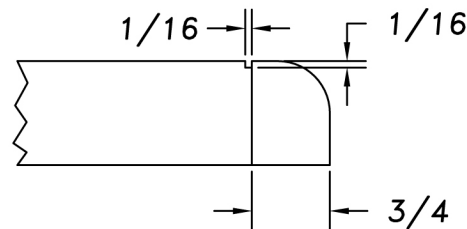

EDGE DETAIL

ACOUSTAT A DIVISION OF ROCKFORD CORP
4400 WOOD BASE