

Acoustic 150, 134 & 135 Service Manual

(note: 150B, 136 and 140 are similar;
those models used two 17-10 preamp boards
instead of one 17-10 and one 17-11)

150 AMPLIFIERS—FOR THE MUSICIAN ON TOUR

model 154

model 155

model 153

model 152



150 SERIES—LIGHT-WEIGHT, PORTABLE AMPLIFIERS WITH FULL POWER AND RUGGED CONSTRUCTION

MODEL 151 is a general purpose amplifier. It combines special effects for lead with two 12" speakers. This speaker system provides good bass with quick response.

MODEL 152 combines special effect circuits for the lead guitar with two 15" speakers for a richer bottom end.

MODEL 153 for electric bass. This system includes two 15" speakers and an amplifier specially designed for the bass range.

MODEL 154 for lead guitar with special effect circuits and six 10" speakers. The speaker system combines maximum sustain with instantaneous response.

MODEL 155 provides special effects for lead with four 12" speakers for maximum sound, good bass, and smooth response.

MODULAR CONSTRUCTION SPEEDS REPAIRS

We've done everything we can to make this the most reliable equipment on the market.

- We use solid state circuitry
- We use computer grade components and wiring techniques
- We provide a lifetime guarantee (page 3)
- We provide service centers in every major city in the country

But this is electronic equipment being used to its full capacity and parts can blow. So we go one step further, we use modular construction for fast, on-the-spot repairs. It's easy to track a trouble to a plug-in board—it's easy to snap in a replacement.

It's easy—even at three o'clock in the morning.

SPECIFICATIONS

Power Output

RMS Continuous 110 Watts
 Peak Music Power 240 Watts

Preamplifier Gain x20 (high gain input)

Signal-to-noise Ratio 80 db

Inputs 4 (high and low gain per channel)

Output Jacks

Auxiliary Power 1—110 Volts AC outlet
 Booster Outputs 1 (for use with Model 200 power amplifier and extra speaker system)
 Footswitch Reverb and Tremolo (except 153)
 Speaker 2 speaker output jacks

Controls

Channel 1 Volume, Treble, Bass, Bright Switch
 Channel 2 Volume, Treble, Bass, Bright Switch, Reverb, Tremolo Speed and Intensity (No Reverb and Tremolo on 153). Power On-Off, Light, and Ground Reverse Switch.

Speaker Cabinets

151, 152, 153, 154 36" H by 24" W by 12" D
 155 To be Announced
 Amplifier Cabinet 5½" H by 24" W by 12" D

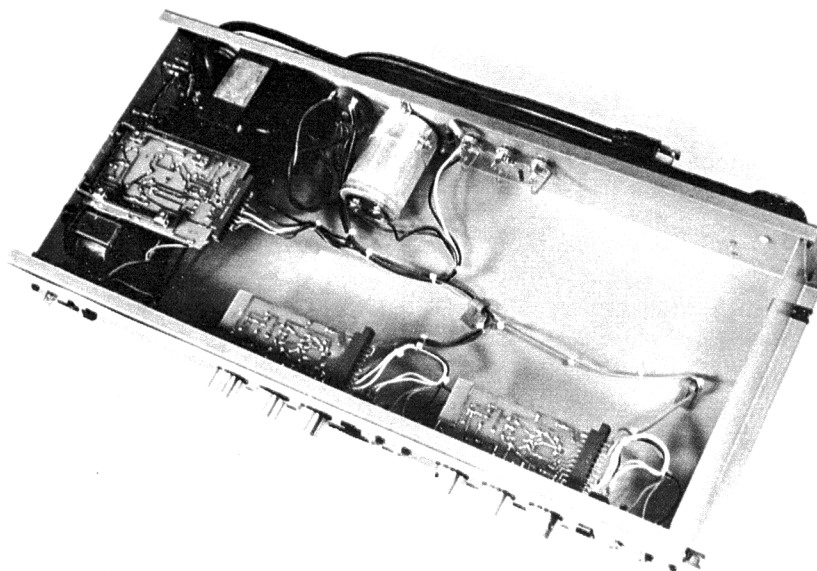

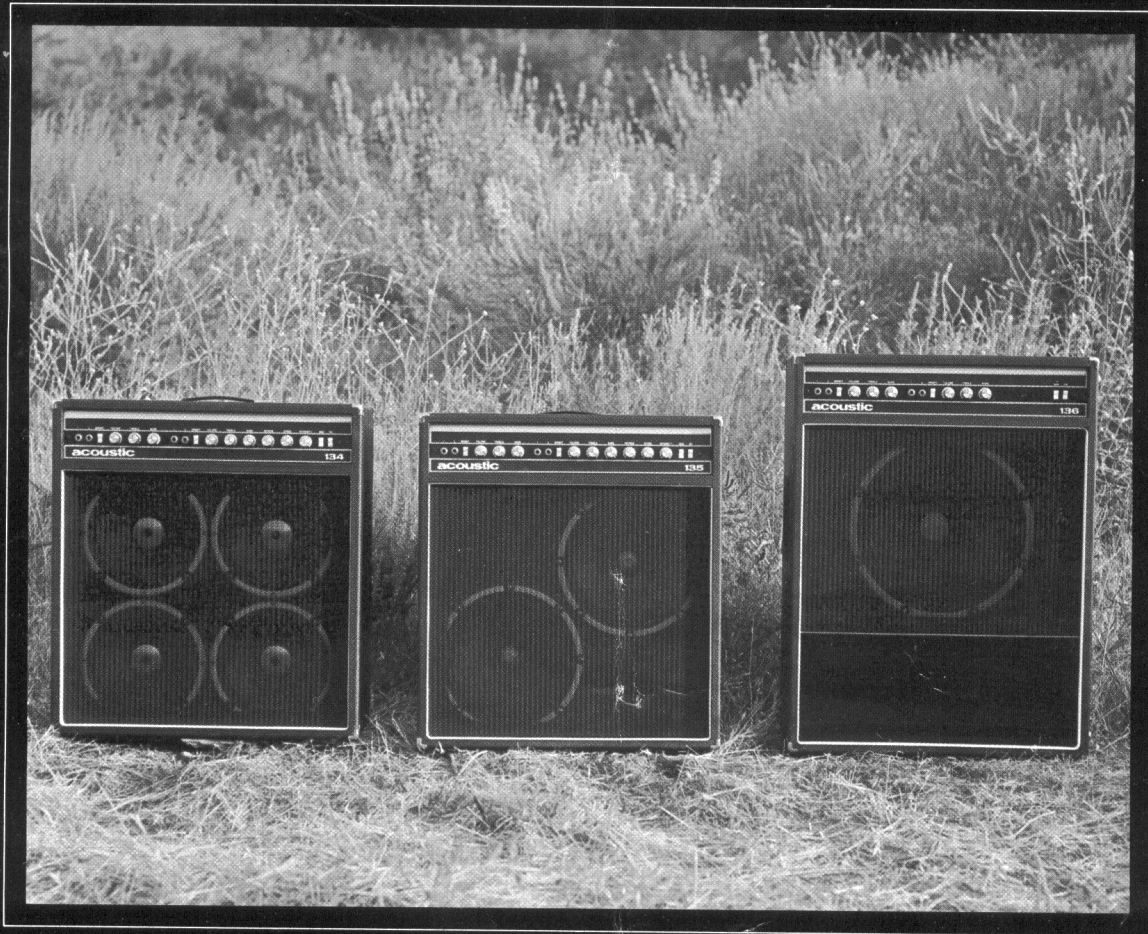

MODEL 134—GUITAR AMP

250 Watts Peak, 125 Watts RMS
4—10" Speakers in an Open Back Cabinet

Features—Channel 1
High & Low Gain Inputs, Bright Switch, Volume, Treble, Bass

Features—Channel 2
High & Low Gain Inputs, Bright Switch, Volume, Treble, Bass, Reverb & Tremolo

Dimensions: 28" H x 25" W x 12" D

Total Shipping Weight: 80 lbs.

With Soft Cover

MODEL 135—GUITAR AMP

250 Watts Peak, 125 Watts RMS
2—12" Speakers in an Open Back Cabinet

Features—Channel 1
High & Low Gain Inputs, Bright Switch, Volume, Treble, Bass

Features—Channel 2
High & Low Gain Inputs, Bright Switch, Volume, Treble, Bass, Reverb & Tremolo

Dimensions: 28" H x 25" W x 12" D

Total Shipping Weight: 80 lbs.

With Soft Cover

MODEL 136—BASS AMP

250 Watts Peak, 125 Watts RMS
1—15" Speaker in a Horn Loaded, Ducted Port Design

Features—Channel 1
High & Low Gain Inputs, Bright Switch, Volume, Treble, Bass

Features—Channel 2
High & Low Gain Inputs, Bright Switch, Volume, Treble, Bass

Dimensions: 33½" H x 25" W x 14" D

Total Shipping Weight: 85 lbs.

With Soft Cover



MODEL 154—GUITAR AMP

250 Watts Peak, 125 Watts RMS
6—10" Speakers in Sealed System

Features—Channel 1
High & Low Gain Inputs, Bright
Switch, Volume, Treble, Bass

Features—Channel 2
High & Low Gain Inputs, Bright
Switch, Volume, Treble, Bass,
Reverb & Tremolo

150 Top: 6" H x 24" W x 12" D
104 Bottom: 36" H x 24" W x 12" D
Total Shipping Weight—115 lbs.
Includes Soft Covers and Wheels

MODEL 155—GUITAR AMP

250 Watts Peak, 125 Watts RMS
4—12" Speakers in Sealed System

Features—Channel 1
High & Low Gain Inputs, Bright
Switch, Volume, Treble, Bass

Features—Channel 2
High & Low Gain Inputs, Bright
Switch, Volume, Treble, Bass,
Reverb & Tremolo

150 Top: 6" H x 24" W x 12" D
105 Bottom: 36" H x 30" W x 15" D
Total Shipping Weight—140 lbs.
Includes Soft Covers and Wheels

MODEL 146—BASS AMP

250 Watts Peak, 125 Watts RMS
2—15" Speakers in Ported Enclosure

Features—Channel 1
High & Low Gain Inputs, Bright
Switch, Volume, Treble, Bass

Features—Channel 2
High & Low Gain Inputs, Bright
Switch, Volume, Treble, Bass

140 Top: 6" H x 24" W x 12" D
106 Bottom: 36" H x 30" W x 15" D
Total Shipping Weight—135 lbs.
Includes Soft Covers and Wheels

MODEL 149—BASS AMP

Similar to Model 146 but with
2—Altec 15" Speakers

ACOUSTIC SERVICE MANUAL

Models 150, 134, and 135

	Page
I. General Information	1
A. Description	1
B. Specifications	1
II. Theory of Operations	1
III. General Troubleshooting	2
1) Equipment Required	2
2) Preliminary Checks	2
3) Detailed Testing and Voltage Tables	3
IV. Schematic Diagrams and Illustrations	
A. Pre Amp P.C. Board Schematic 17-10	10
B. Pre Amp P.C. Board Schematic 17-11	11
C. Power Amp P.C. Board Schematic 17-12	12
D. Power Supply and Chassis Wiring	13
E. Pre Amp P.C. Board Photo 17-10	14
F. Pre Amp P.C. Board Photo 17-11	15
G. Power Amp P.C. Board 17-12	16
H. Power Amp Wiring Photo 14-40	17
V. Control Locations	18
VI. Speaker and Network Wiring	19
VII. Troubleshooting Chart	24
VIII. Parts List	26
IX. Specifications	29

I. GENERAL INFORMATION

A. Description

The model 150 is an amplifier and speaker enclosure combination designed for use with rhythm or lead guitars. The preamplifier and power amplifier are in a wooden cabinet separate from the speaker enclosure. The unit has reverberation and tremolo circuits in one channel and has a second channel with treble/bass/volume controls. A foot switch panel is supplied which lies on the floor and controls the tremolo and reverberation effects. Model 134 and 135 are the same except for single cabinet construction.

B. Specifications

Channel 1 — hi & lo gain inputs; bright switch volume/treble/bass

Channel 2 — hi & lo gain inputs; bright switch volume/treble/bass; reverb; tremolo speed & intensity

Power output = 110W RMS (240W p)

Model	154	155	156	134	135
Speaker	6-10"	2-12"	2-15"	2-12"	4-10"
Encloser	Sealed	Sealed	Ported	Open	Open

II. THEORY OF OPERATION

For the following description it will be necessary to refer to the associated schematic diagrams.

- 1) 17-10 Preamp Board — Q101 and Q102 are connected in a feedback pair amplifier configuration. The amplifier gain is fixed at X17 (voltage gain). R109 is a conventional volume control whose wiper feeds signal to Q103 via C107. Q103 is a tone control/amplifier stage. The voltage gain from Q103's base to collector and emitter is approximately unity. When R114 and R116 are in the midposition, the frequency response of stage Q103 is flat. When R114 is at the low end (full cw), the bass frequencies are amplified more than the treble frequencies because the reactance of L101 increases at higher frequencies. When R114 is at the upper end (full ccw), the bass frequencies are amplified less than the treble frequencies. The treble control, R116, has a similar effect using a capacitive reactance instead of inductance and affects frequencies in the opposite directions. R119 and C111 form a stage of decoupling from the +75 source. R118 and C105 form a second decoupling network.
- 2) 17-11 Preamp Board — Q206 and Q207 form an amplifier as in the 17-10 board. Q208 is an emitter follower driven with a portion of the collector voltage of Q207. Q209 is a class A stage operating at a fairly high current which drives the input coil of the reverberation spring. The pick-up or output coil of the spring supplies signal to Q210. Q210 amplifies the delayed signal and applies it to R234 via R233. The upper end of R233 receives the direct amplified signal from Q207. The wiper of R234 applies a mixture of direct and delayed signal to Q212. Q211 is a field effect transistor which is normally biased completely off by the voltage divider R229 and R230. In this condition the drain to source resistance is extremely high and the FET does not hinder the passing of signal to R233. Point 'c' is connected to the foot switch jack J409 and when a foot switch shorts 'c' to ground, the FET is biased with zero volts on

its gate terminal. This results in a very low value of drain-to-source resistance which effectively shunts all signal to ground. This is how the reverberation signal is turned off and on by the foot switch. Q212 is an emitter follower which drives the volume control R240. Stage Q213 operates as a tone control amplifier similar to 17-10 preamp. Signal output is taken from point 'E'. Q201, Q202, and Q203 are connected as an amplifier with positive feedback. The result is an oscillator. Q204 and Q205 are connected in Darlington fashion and provide current amplification sufficient to drive the incandescent lamp bulb in the light dependent resistor. R206 controls the frequency of the oscillator while R213 controls the level of drive to the lamp bulb. When R213 is turned cw, the lamp bulb flickers in intensity at the oscillator rate. The bulb is enclosed in a light-tight enclosure along with a light-dependent resistor (LDR). The LDR's resistance varies from infinity in darkness to a few thousand ohms for full illumination from the lamp. The LDR's resistance will now vary at the OSC rate and through limits determined by the setting of R213. One end of the LDR is grounded while the remaining end is connected to point 'E'. The effect of the LDR is to load stage Q213 to a more or lesser degree which causes the gain of Q213 to vary. This in turn causes the output signal level to vary up and down giving the tremolo effect desired. The signals from 17-10 and 17-11 preamp boards are summed together and applied to the power amplifier section by R301 and R302.

- 3) 17-12 Power Amp Board – Q301 and Q302 are connected as a feedback pair amplifier of sufficient gain and power to drive the primary of the output driver transformer (see power module circuit 17-12). Q303 and Q304 supply drive to the load during positive signal excursions while Q305 and Q306 supply drive during negative signal excursions. The resistor divider chain R312, R314, R313, R315 set the output transistor bias voltages and currents. C311's positive end is at one half the supply voltage. R316 and R317 are in shunt connection with two portions of the resistive chain. These two resistors lower their resistance as temperature increases and thus serve to hold the bias current in the output transistors to a safe value at elevated temperatures. R310 and C308 form a feedback network around the amplifier.

III. GENERAL TROUBLESHOOTING

- 1) Equipment Required
 - a) FET VM or VTVM
 - b) VOM with 20 k/v rating.
 - c) 5 amp VARIAC with line voltage meter.
 - d) Audio signal generator with output level control and calibrated frequency dial.
 - e) Oscilloscope with good sync capability and calibrated vertical amplifier.
- 2) Preliminary Checks – It is often difficult to establish meaningful communication between the equipment user and the technically qualified man whose duty it is to effect the repair of the equipment. With this in mind, the repair technician should either have the customer demonstrate the problem or connect an instrument to the amplifier and determine the problem himself. Once a problem has been found, the next step is to remove the chassis from its cabinet and give a thorough visual inspection of the wiring and components on the circuit cards. When visually inspecting a chassis, be ready for anything as someone may have been into the equipment at a previous time. Inspect the power card and the fuse and

apply power to the unit. Measure the positive end of C401 with respect to ground. This should measure +70V when the line voltage is 120 VAC.

3) Detailed Testing and Voltage Tables

- a) 17-10 Card — Set the audio signal generator to 1000 Hz and adjust the level to 8 mvpp [Note: all signal levels in this text are given in peak-to-peak ratings] after applying to the high gain input of Channel 1. This will apply signal to the 17-10 circuit card.

The following table gives the normal operating signal levels.

Peak to Peak			
Q	Collector	Base	Emitter
101	—	8 mv	8 mv
102	140 mv	—	0
103	180 mv	140 mv	140 mv

Frequency Response — Place scope probe on the collector of Q103. Ground, with a jumper clip lead, the junction of R301 and R302 on the power amplifier card 17-12. Other conditions are the same as above with the exceptions noted below in the table.

Freq.	Conditions and Levels		
7.5 KHz	Treble cw	1.2 V	Treble ccw
100 Hz	Bass cw	0.5V	Bass ccw
400 Hz	Bass/Treble cw	0.3 V	Bass/Treble ccw 160 mv

- b) 17-11 Circuit Card — Refer to schematic diagram, Page 11, and to photographs for component locations. Apply signal to the high gain input of Channel 2. Set the generator to 1000 Hz and 8 mvpp signal level. The following table indicates the correct signal levels.

Conditions — speed — cw/int — ccw/rev — ccw/treble and bass — mid/bright sw. — off

Q	Collector	Base	Emitter
206	—	8 mv	8 mv
207	150 mv	—	0
208	0	8 mv	8 mv
209	400 mv	8 mv	7 mv
212	0	150 mv	150 mv
213	225 mv	150 mv	150 mv

Conditions: Line = 120 VAC Frequency = 1000 Hz
 Volume = full cw Level = 8 mv at hi gain input
 Bass = middle Bright sw. = off
 Treble = middle

To test the reverb preamp, disconnect the reverb spring output phono plug from the spring and apply signal from the generator directly to the plug. Set the level to 8 mv. The following levels should exist at Q210:

Base — 8 mv
 Collector — 20 mv
 Emitter — 0

Note: Be sure that the foot switch is disconnected from the foot switch jack, J409.

Frequency response of the tone amplifier Q213 is tabulated below. Again it is necessary to ground the junction of R301 and R302. Scope probe at collector of Q213.

Freq.	Conditions and Levels	
7.5 KHz	Treble cw — 1.4V	Treble ccw —
100 Hz	Bass cw — 0.55V	Bass ccw —
400 Hz	Bass and Treble cw — 0.3V	Bass and Treble ccw 165 mv

The bright switch increases the high frequency gain of the system. To test this set the volume control at 1/2 rotation. Scope probe at Q213c. Set generator frequency at 10 KHz. The level at

Q213's collector should increase by +6 db or about twice the level from bright switch off to bright switch on conditions. This applies to the 17-10 preamp also.

A.C. signal levels in the tremolo oscillator and driver section are tabulated below along with waveforms.

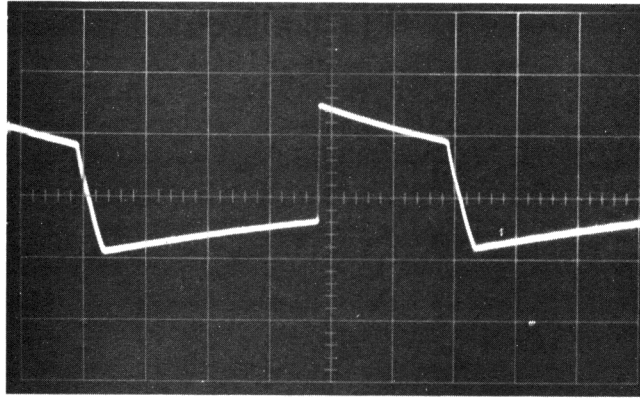

Q201 Collector 35 V P.P.

Conditions — speed-cw; intensity — ccw

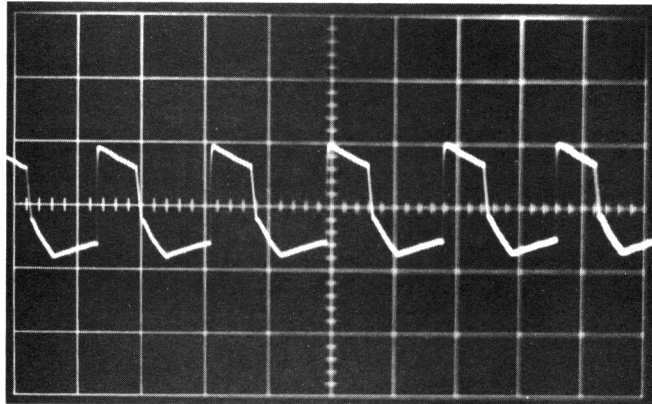

Q202 Base 16 V P.P.
Q203 Base 16 V P.P.

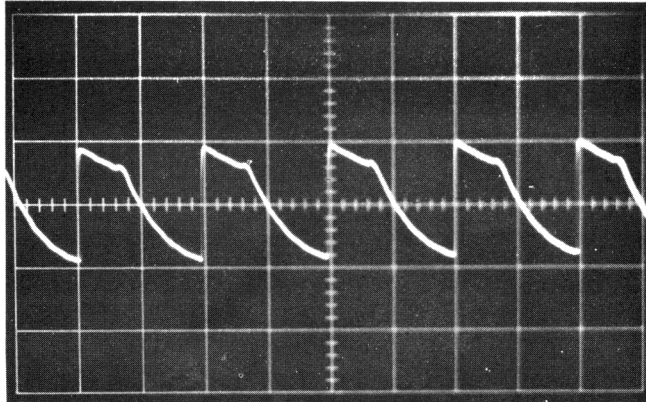

Q202 Emitter
Q203 Emitter

Intensity control – cw

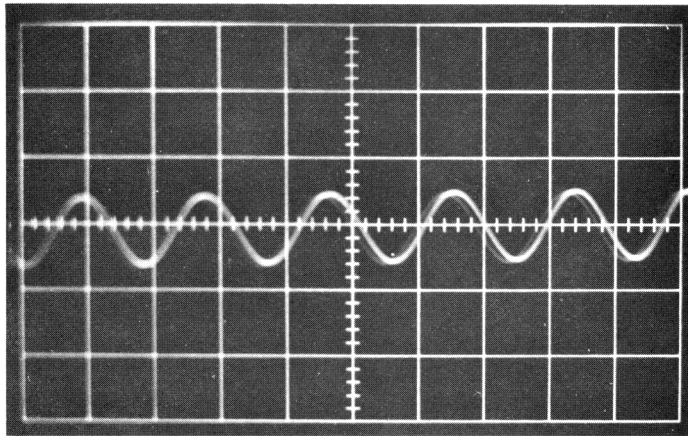

Q204 Base & Emitter 9 V P.P.
Q205 Base & Emitter 9 V P.P.

To this point the text has been concerned with signal tracing and waveforms. During the process of signal tracing, the fault will be found. The following tables indicate the D.C. voltage levels which exist when conditions are correct. Measuring the voltages in the problem area and comparing the readings with those of the table will point directly to the faulty component.

17-10 Preamp Board:

Conditions: line voltage = 120 VAC
 volume/treble/bass = ccw; speed – cw
 rev./volume/treble/bass/intensity = ccw

Q	Collector	Base	Emitter
101	+35.4V #	+1.7V #	+1.1V
102	+19V	+35.4V #	+36V
103	+20V	+9.6V #	+9V

Terminal 'A' on connector = +70V

17-11 Board – [Conditions as for 17-10 board.]

Q	Collector	Base	Emitter
206	+36.9V #	+1.7V #	+1.1V
207	+21.5V	+36.9V #	+37.5V
208	0	+1.1V	+1.7V
209	+20V	+1.7V	+1.2V
210	+6V	+0.6V	0
211	Drain 0	Gate +11V #	Source 0
212	+38V	+26.6V #	+26V
213	+12V	+8.1V #	+7.5V
201	+16V (osc)	+36.4V	+40
202	+36.4	+22.1V (osc)	+21.5V (osc)
203	+14V	+21.1V (osc)	+21.5V (osc)
204	0	+2.7V	+3.3V
205	0	+3.3V	+3.9V

- c) The power module, 17-12 board and associated components will be tested as a separate unit. The chassis end panel serves as a heat sink for the output transistors. It is convenient to isolate the power amplifier from the remaining circuitry for testing. This may be accomplished by temporarily unsoldering the connector ends of both R301 and R302. Signal from the generator may then be applied to either of the free ends of R301 or R302. The following table indicates signal levels at the various points in the circuitry. The conditions are:

Line voltage = 120 VAC; No load; Freq. 1000 Hz

Apply signal as described to R301 or R302 and increase drive until 50 Vpp is reached at the output terminal (negative end of C311). Input level should be about 0.54 Vpp.

Q	Collector	Base	Emitter
301	—	425 mv	425 mv
302	0.6V	—	0
303/304	0	50V	50V
305/306	50V	80V	35 mv

Next, apply a 4Ω load and increase drive again until 50 Vpp is developed across the load. Input level should be about 0.7 Vpp.

Q	Collector	Base	Emitter
301	80 mv (distorted)	0.6V	0.6V
302	37.5V	80 mv (dist)	0
303/304	0	56V	55V
305/306	50V	4.2 (dist)	1.5V

Power Output — Raise drive until clipping just beg ins. Main 120V line. Clipping should occur around 60 Vpp with a 4Ω resistive load. This is equivalent to 110W RMS power out. Power bandwidth should be -3 db at 50 Hz and 15 KHz minimum. This is measured by sweeping the signal generator frequency down and up from 100 Hz until the output voltage drops to 0.7 of its value at 1000 Hz. The value at 1000 Hz should be just at clipping. When measuring the levels at the output transistors under loaded conditions, be certain that all transistors are conducting the same amount. To measure this, first be sure that the scope ground lead is isolated from the power

lines. Place the ground lead on the collection of Q305 or Q306. Place the probe alternately on the emitters of Q303 and Q304. The display should be the same in both cases as is shown below:

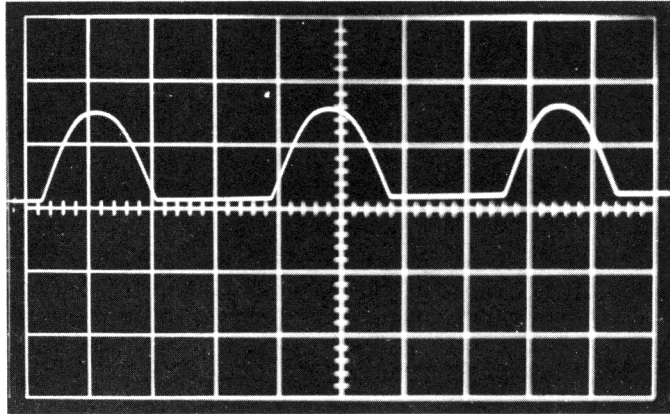

Full Load 60 V P.P.
1.5 Volts

To measure the lower set , place scope ground on circuit ground and probe alternately on the emitters of Q305 and Q306. The display should be the same for both transistors and as shown above.

The D.C. measurements under zero signal conditions are tabulated below: (amplifier cold with no load) 120 VAC line.

Q	Collector	Base	Emitter
301	+30.2V	+12.6V	+12V
302	+3V	+30.2V	+31V
303/304	+70V	+36.5V	+36V
305/306	+36V	+0.6V	Negligible

+75V IN
 A B C D E F H J K L
 SIG OUT
 NC
 SIG IN
 SIG IN
 GND
 BRIGHT SWITCH

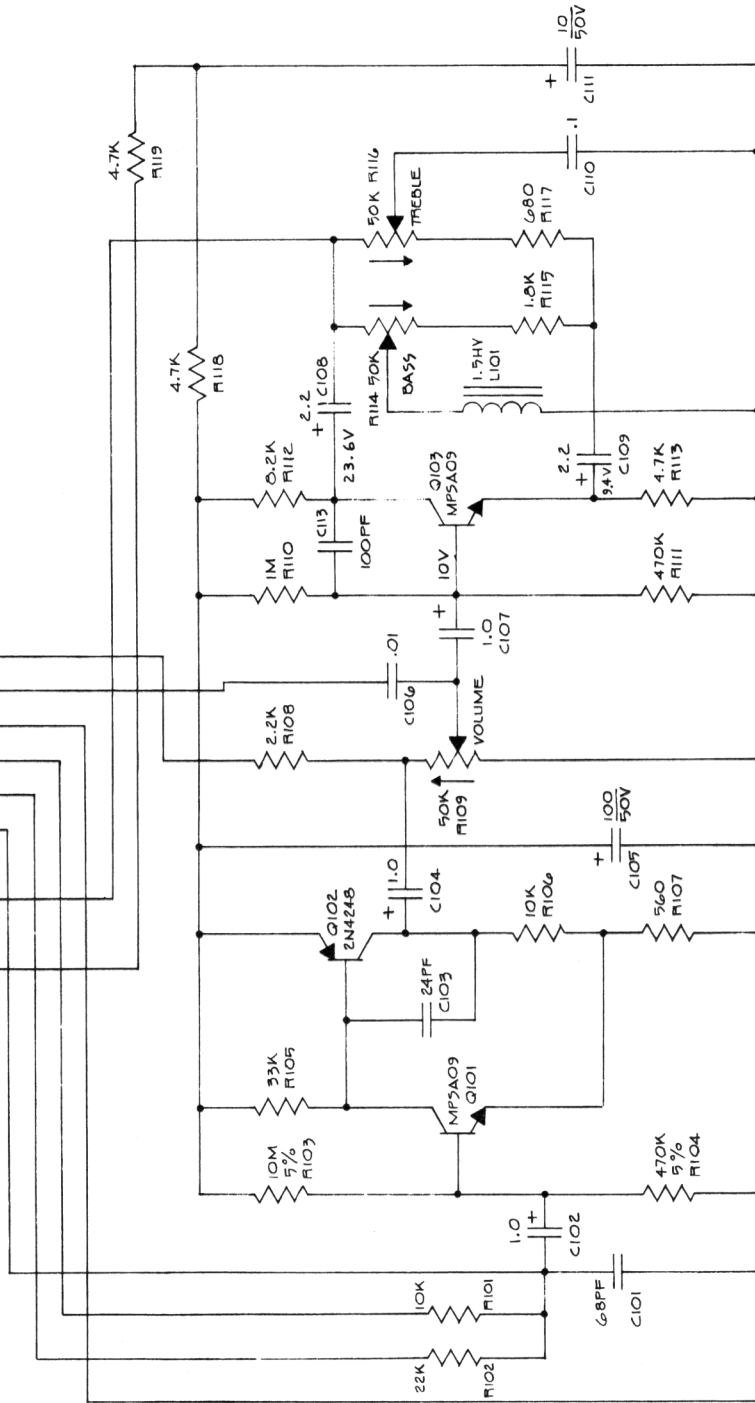

PREAMP (17-10)

ALMADE NEW DMG SCALE: NONE DATE: 1-11-71	APPROVED: DRAWN: J11626A DATE: 1-11-71
SCHEMATIC 17-10	
ACOUSTIC CONTROL CORP. 1104A	

TREMLO OSCILLATOR

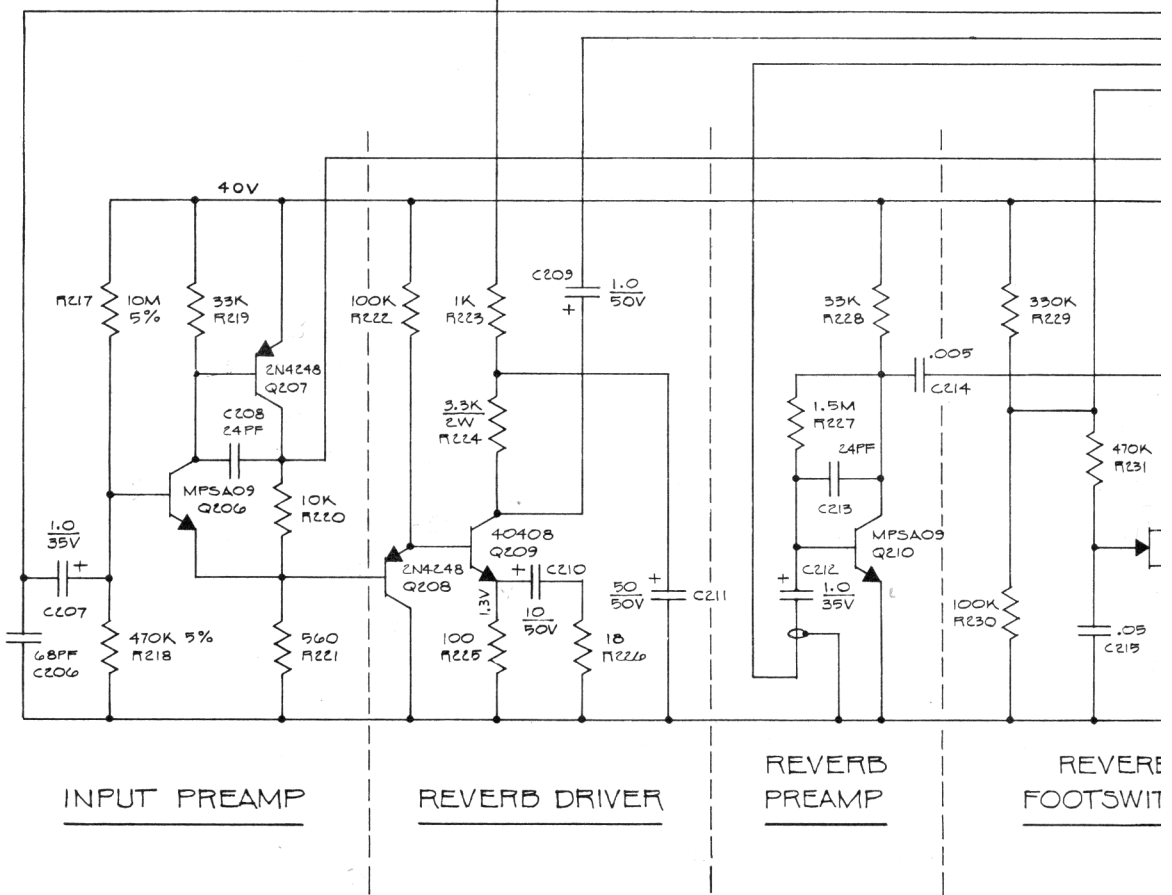
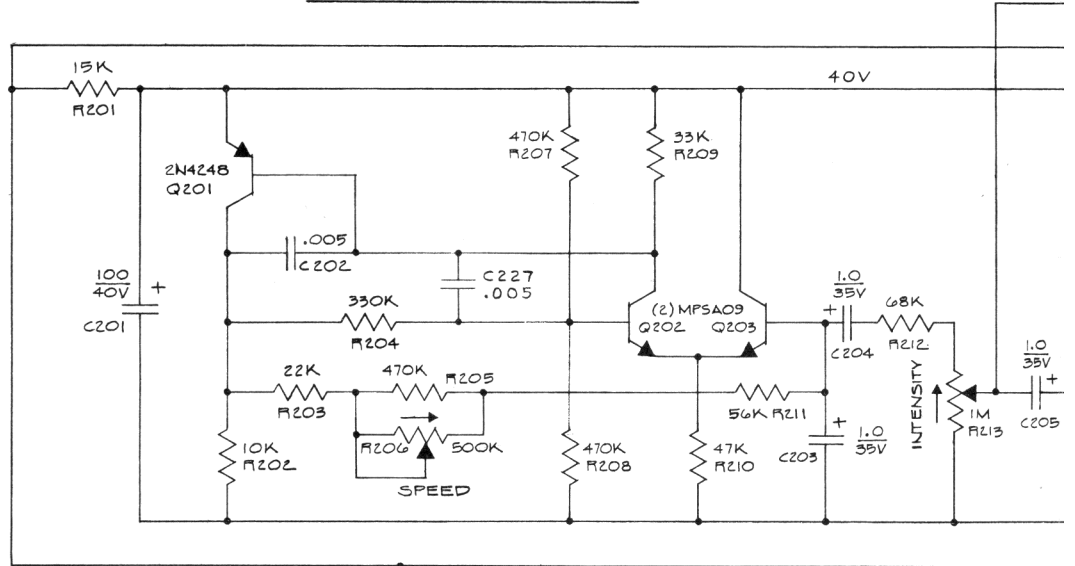

INPUT PREAMP

REVERB DRIVER

REVERB
PREAMP

REVERB
FOOTSWIT

PREAMP (

TREMOLO OSCILLATOR

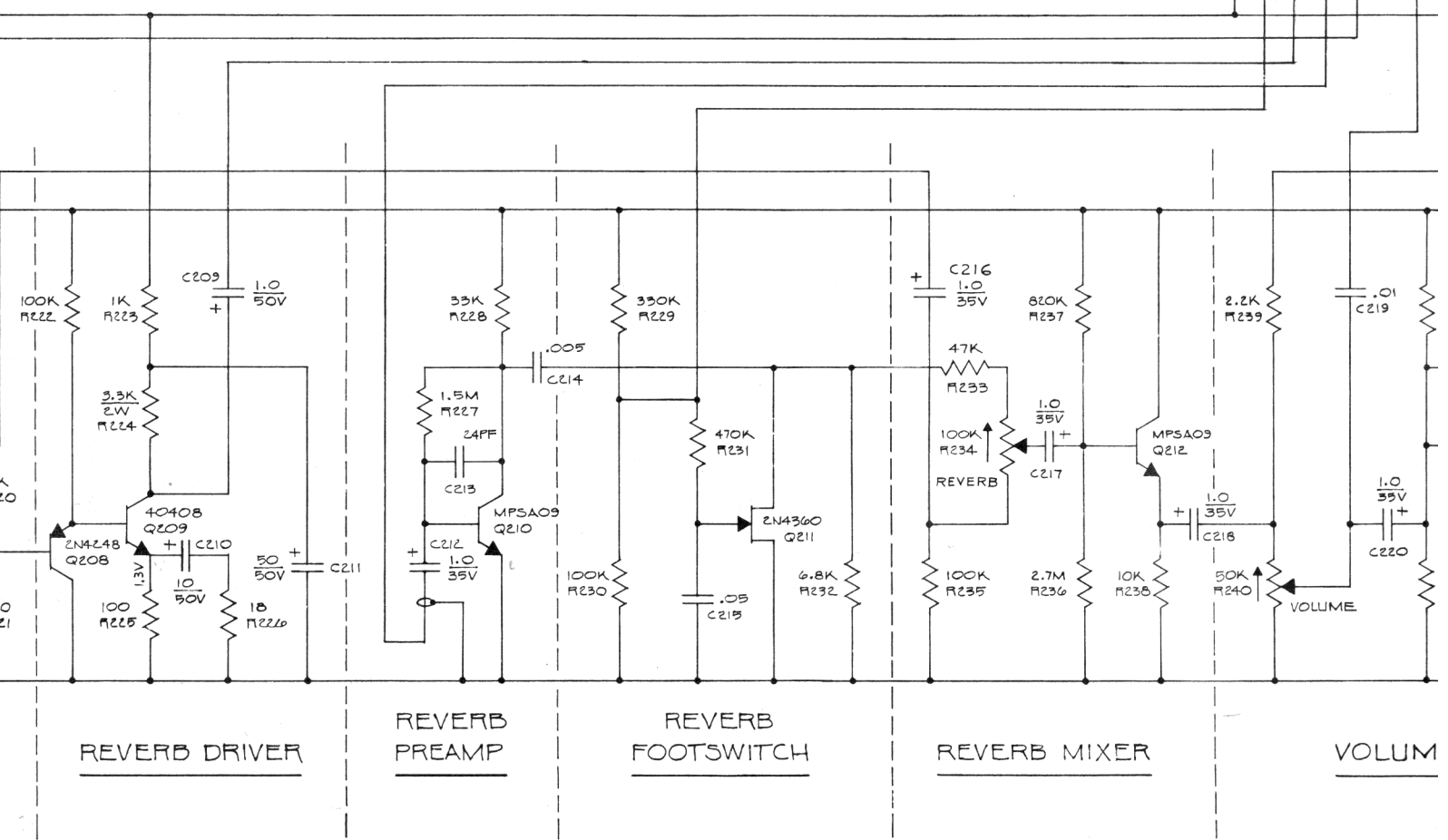
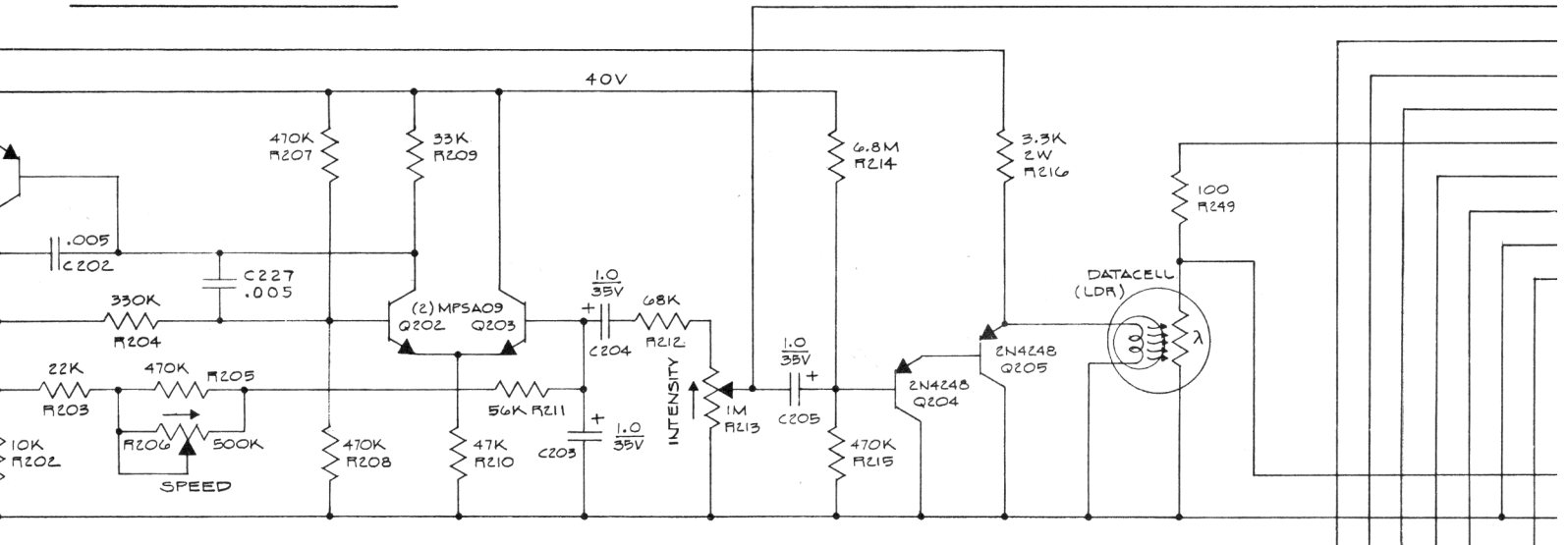

PREAMP (17-11)

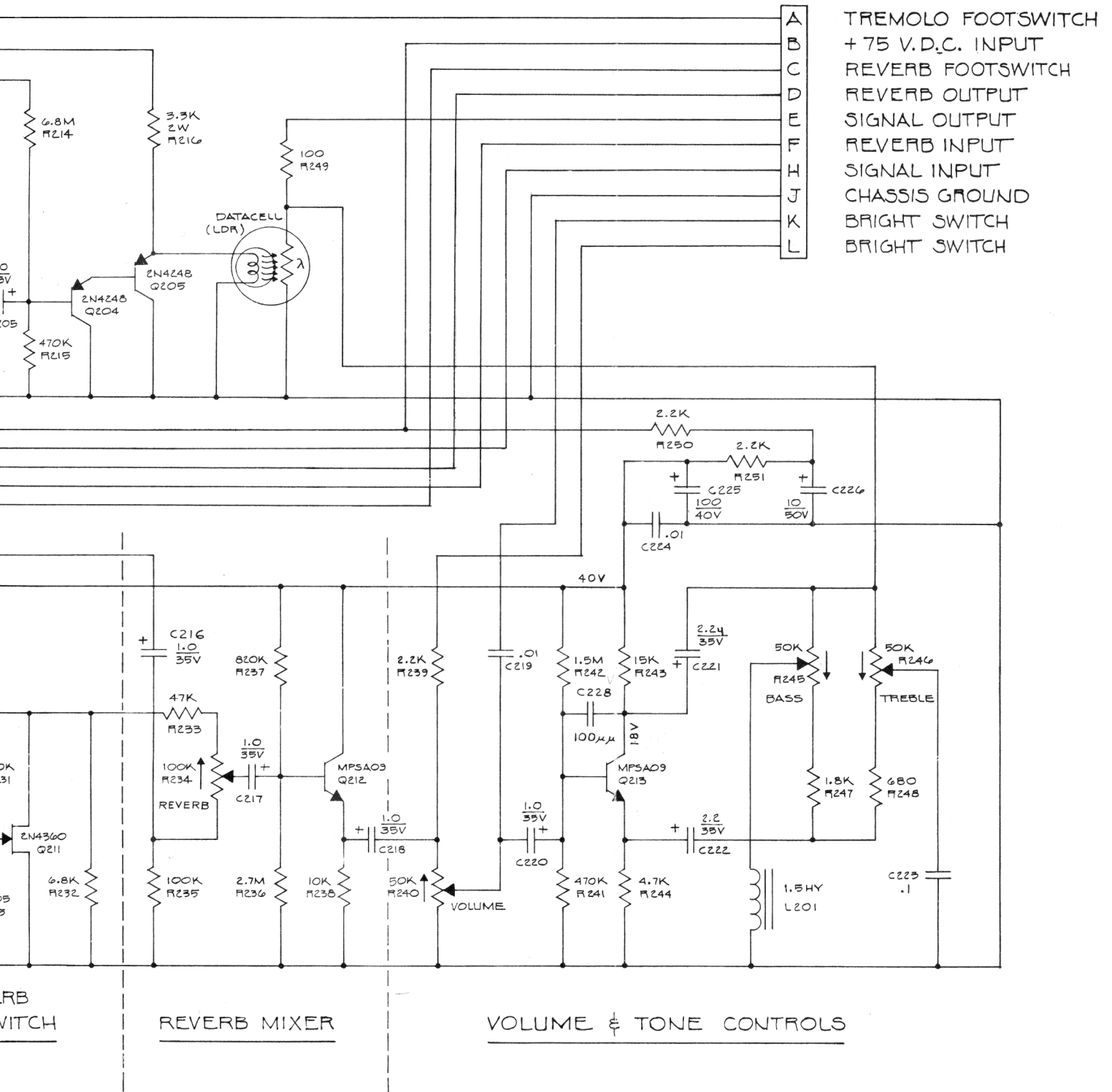

- A TREMOLO FOOTSWITCH
- B + 75 V.D.C. INPUT
- C REVERB FOOTSWITCH
- D REVERB OUTPUT
- E SIGNAL OUTPUT
- F REVERB INPUT
- G SIGNAL INPUT
- H CHASSIS GROUND
- I BRIGHT SWITCH
- J BRIGHT SWITCH

(17-11)

MADE NEW VELLUM	1-26-71 716
SCALE: NONE	DRAWN: <i>W. Smith</i>
DATE: 1-26-71	
SCHEMATIC (17-11)	
ACOUSTIC CONTROL CORP.	DWG NO. 1107A

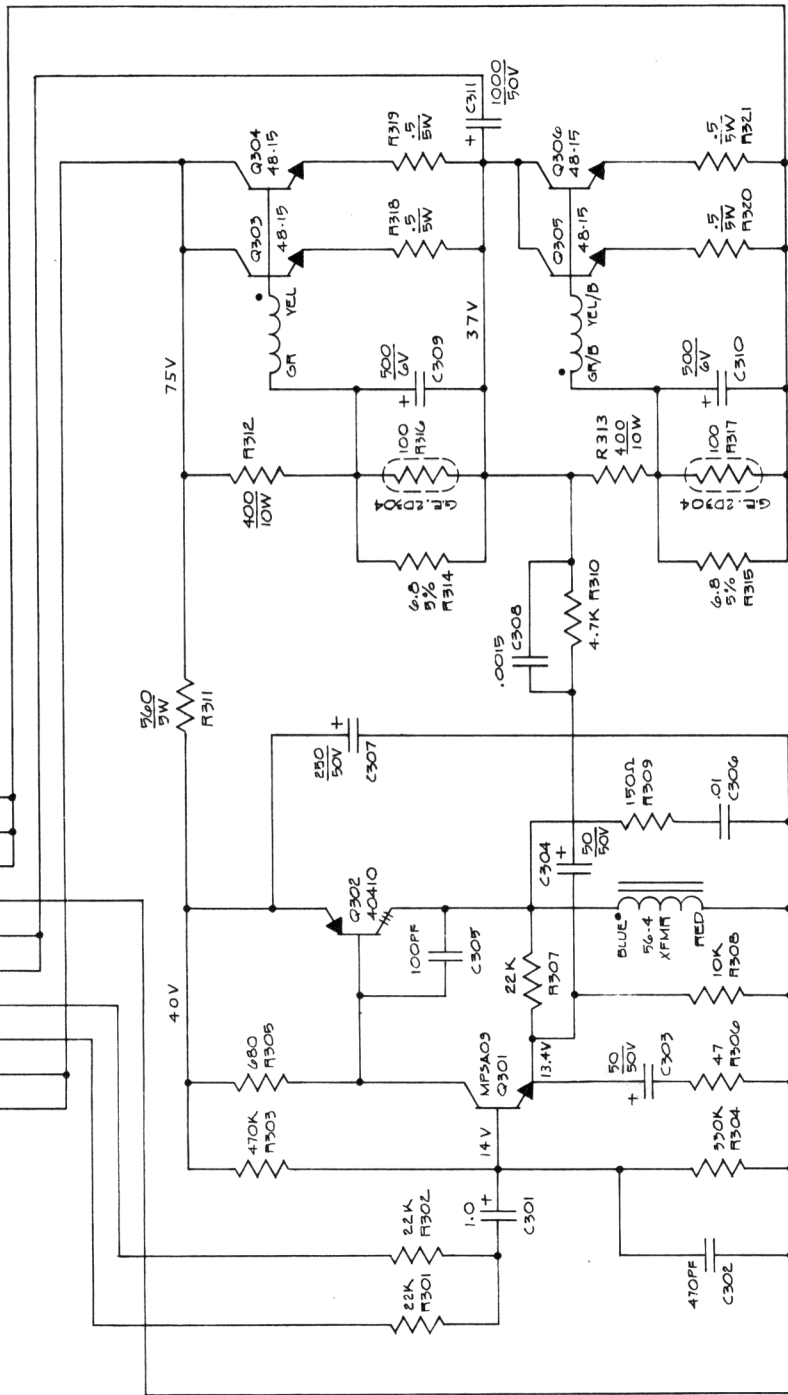
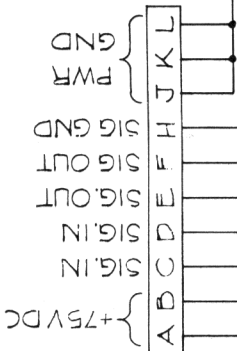

POWER MODULE (17-12)

1-11-71	W/171220
ALL MADE NEW VELLUM	
SCALE NONE	APPROVED
DATE 1-11-71	CRANN JH/171220
SCHEMATIC (17-12)	
ACOUSTIC CONTROL COMP :103A	

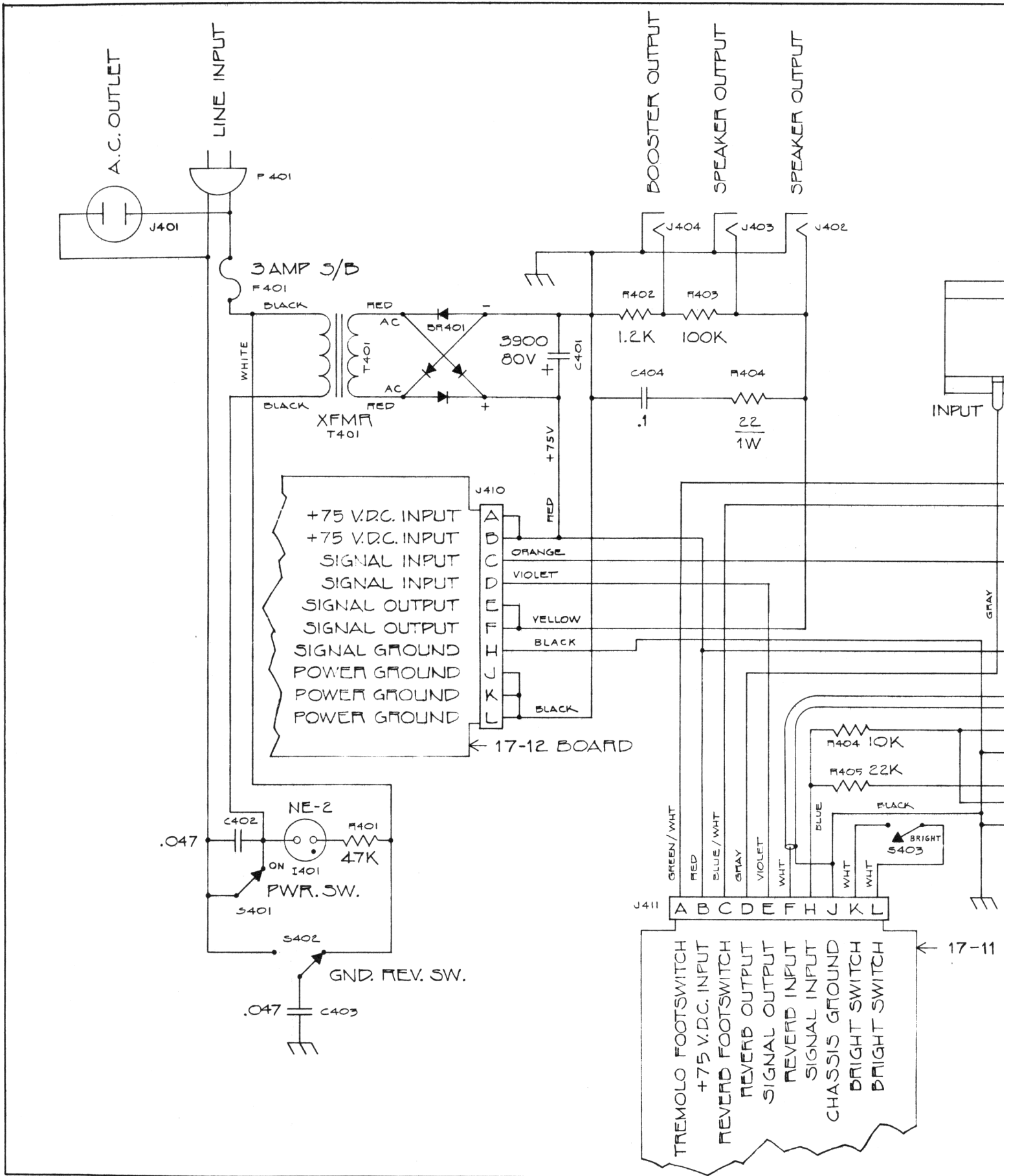

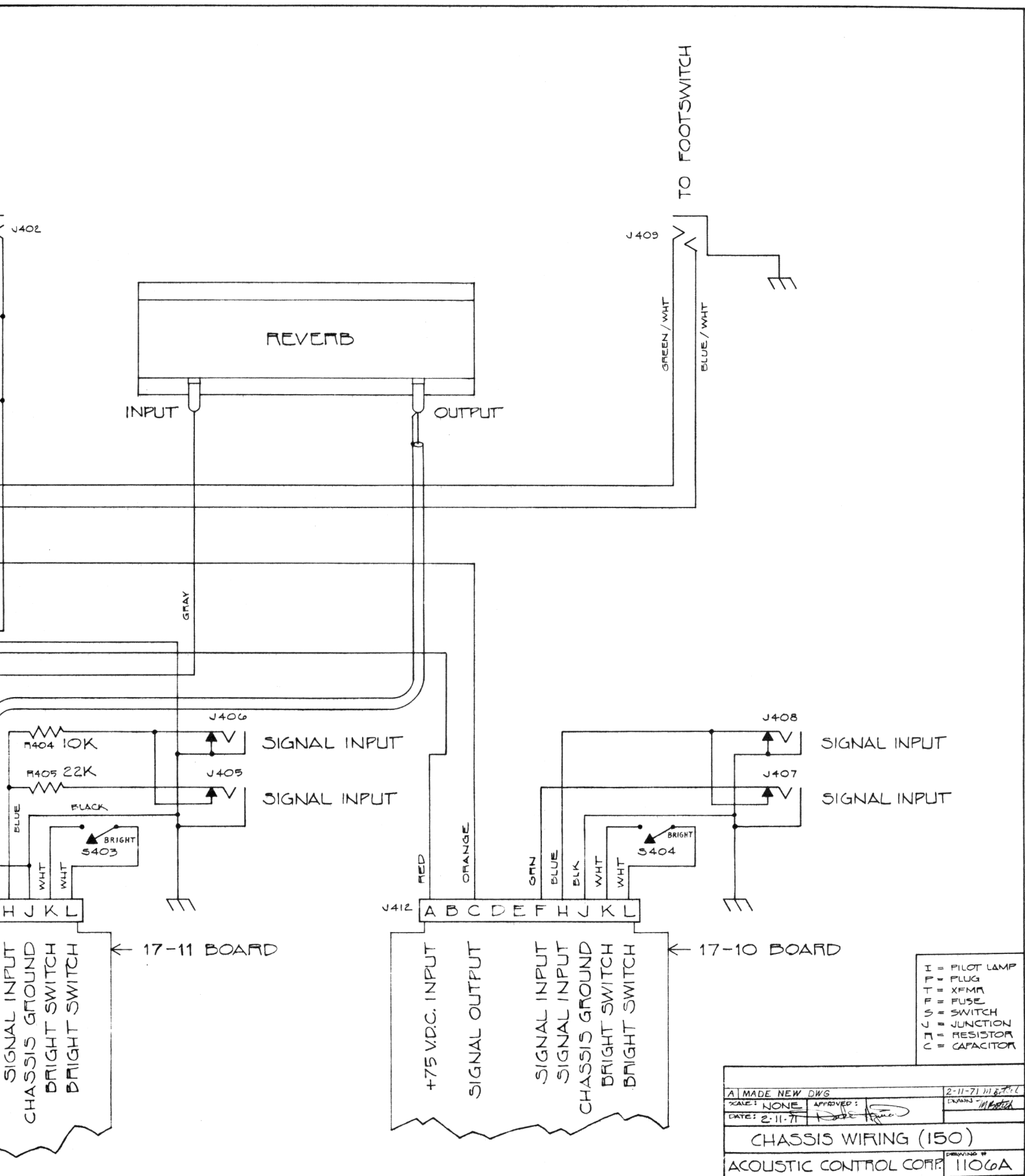

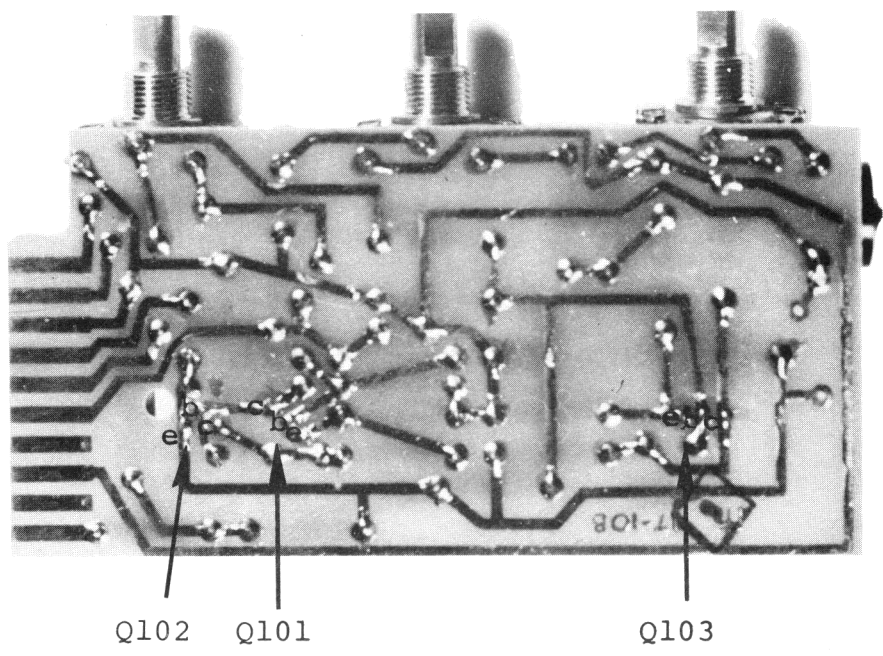
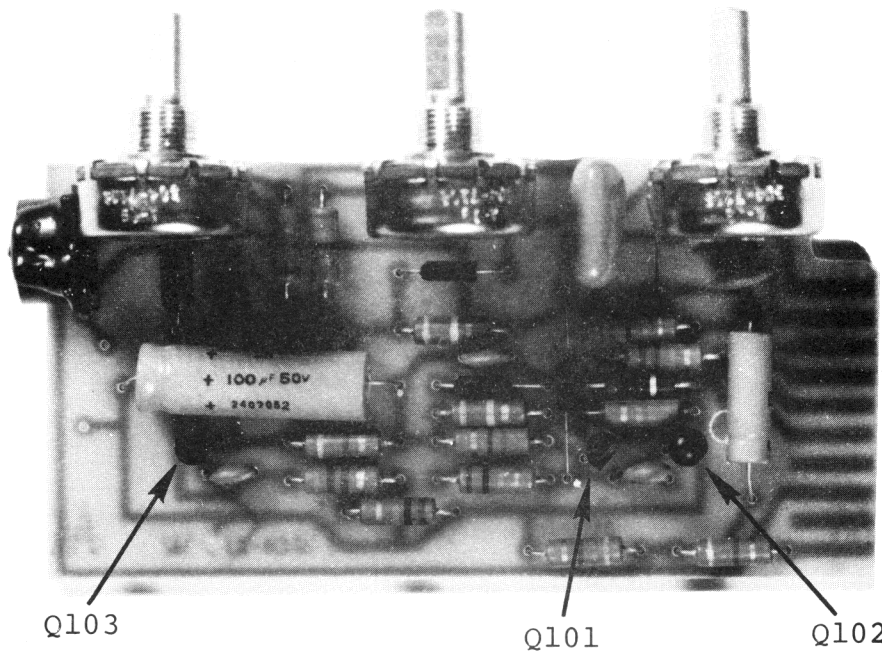

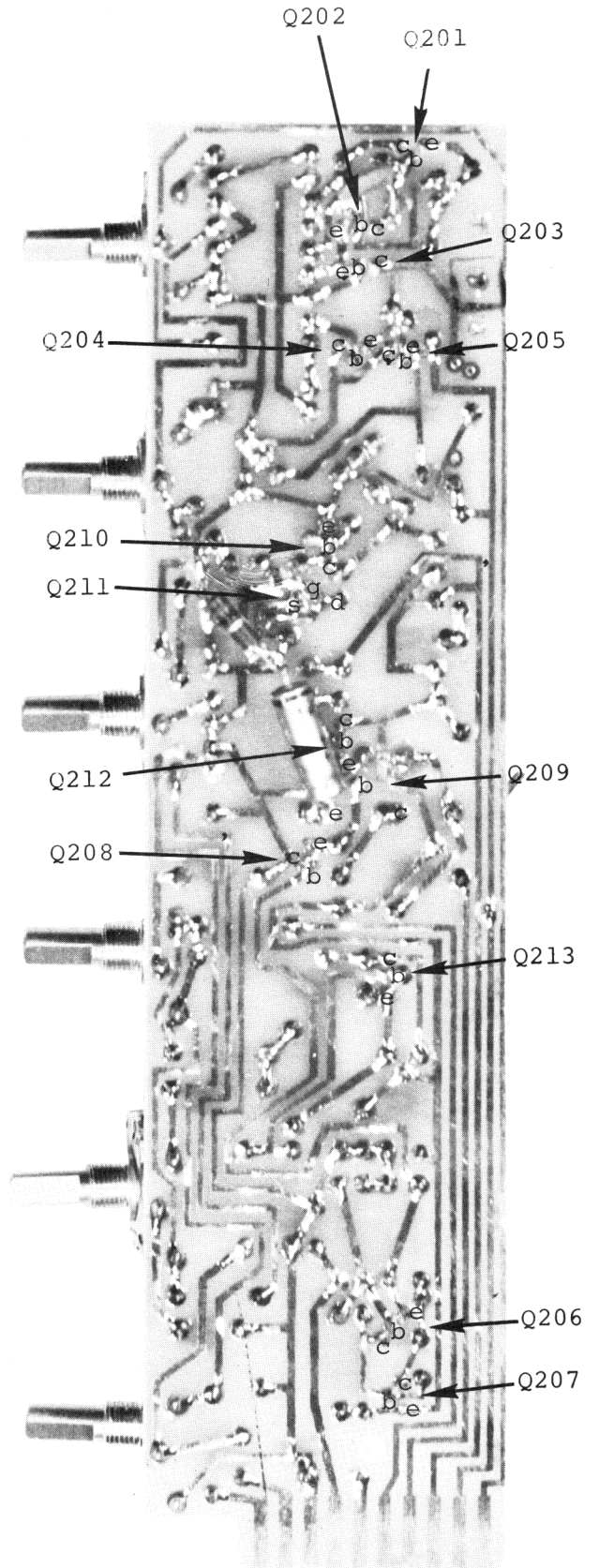
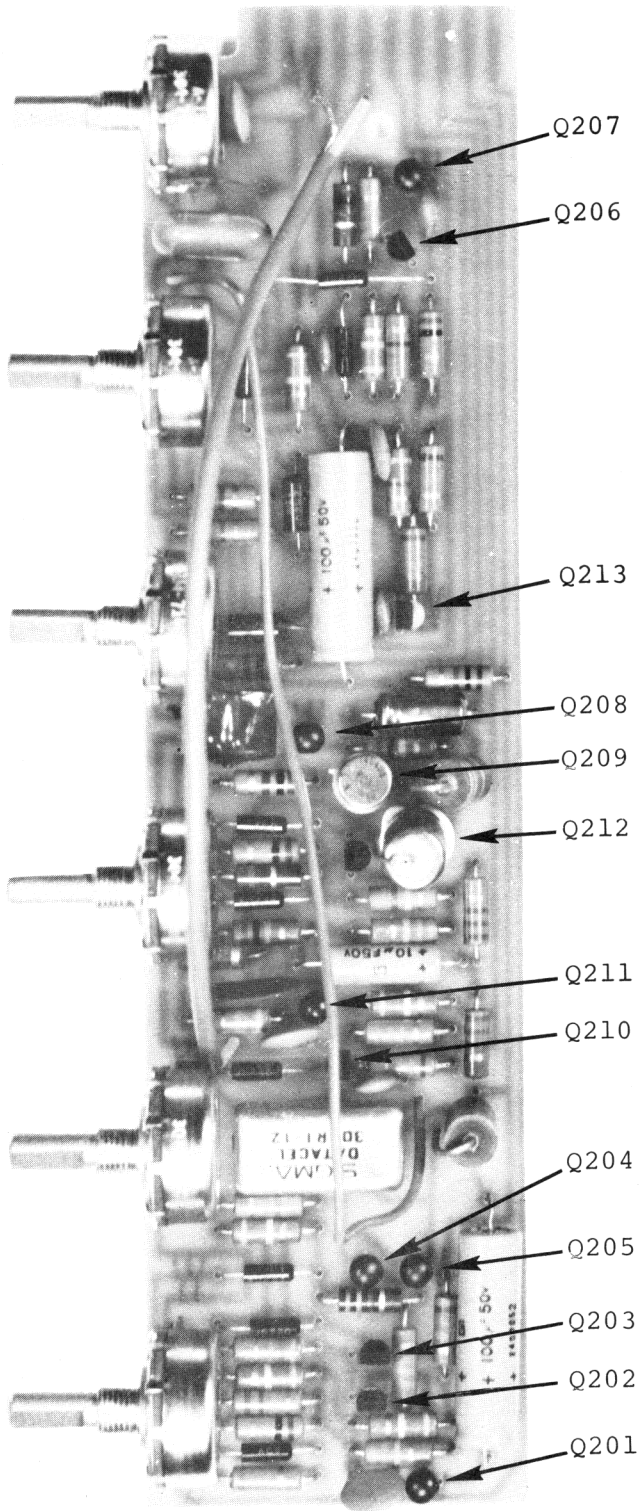

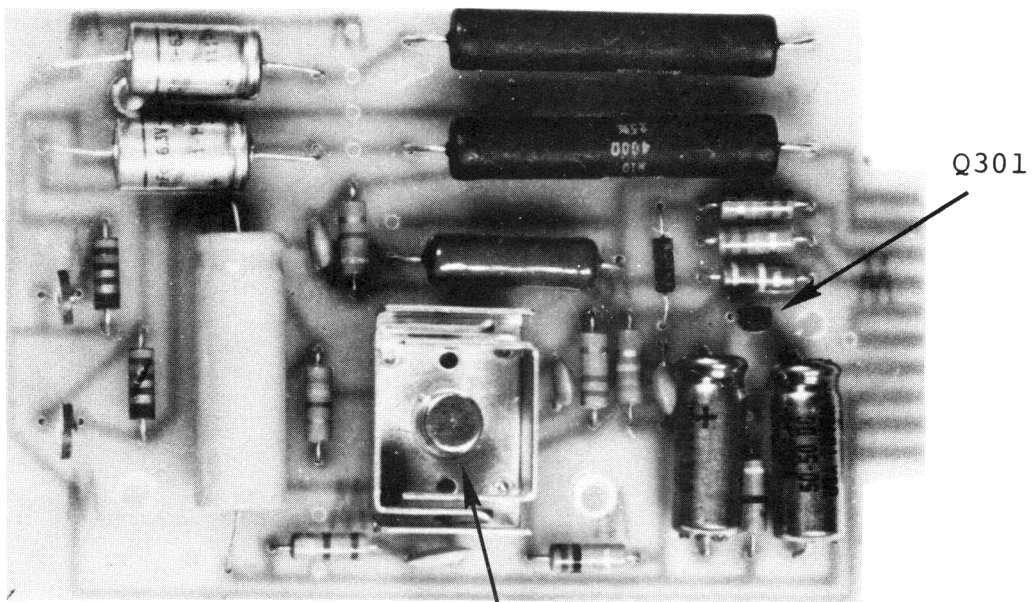
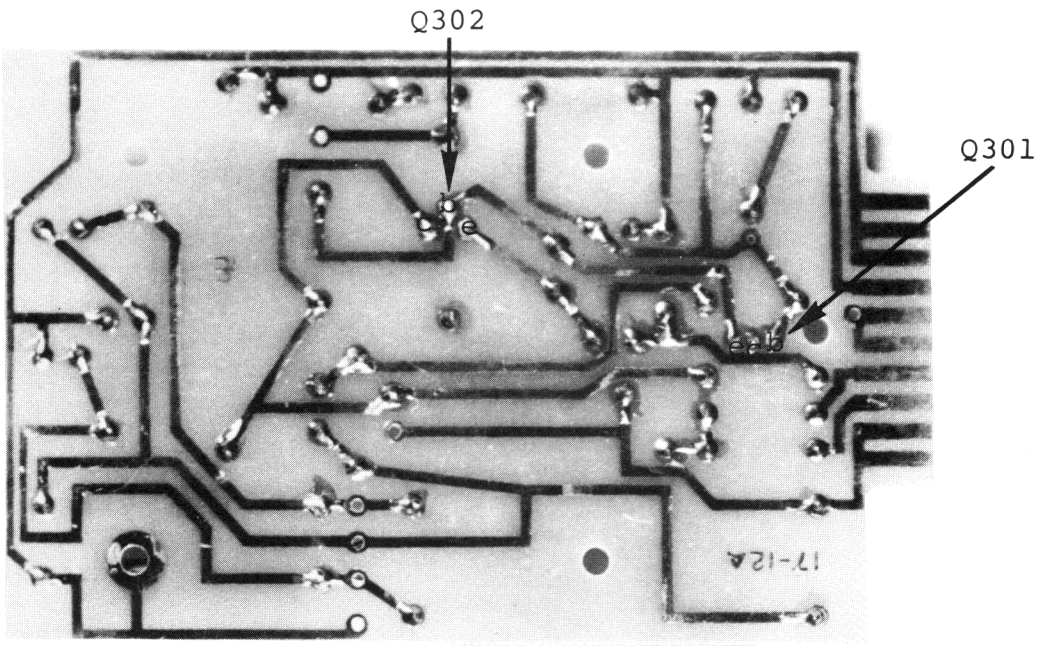

Q302
16

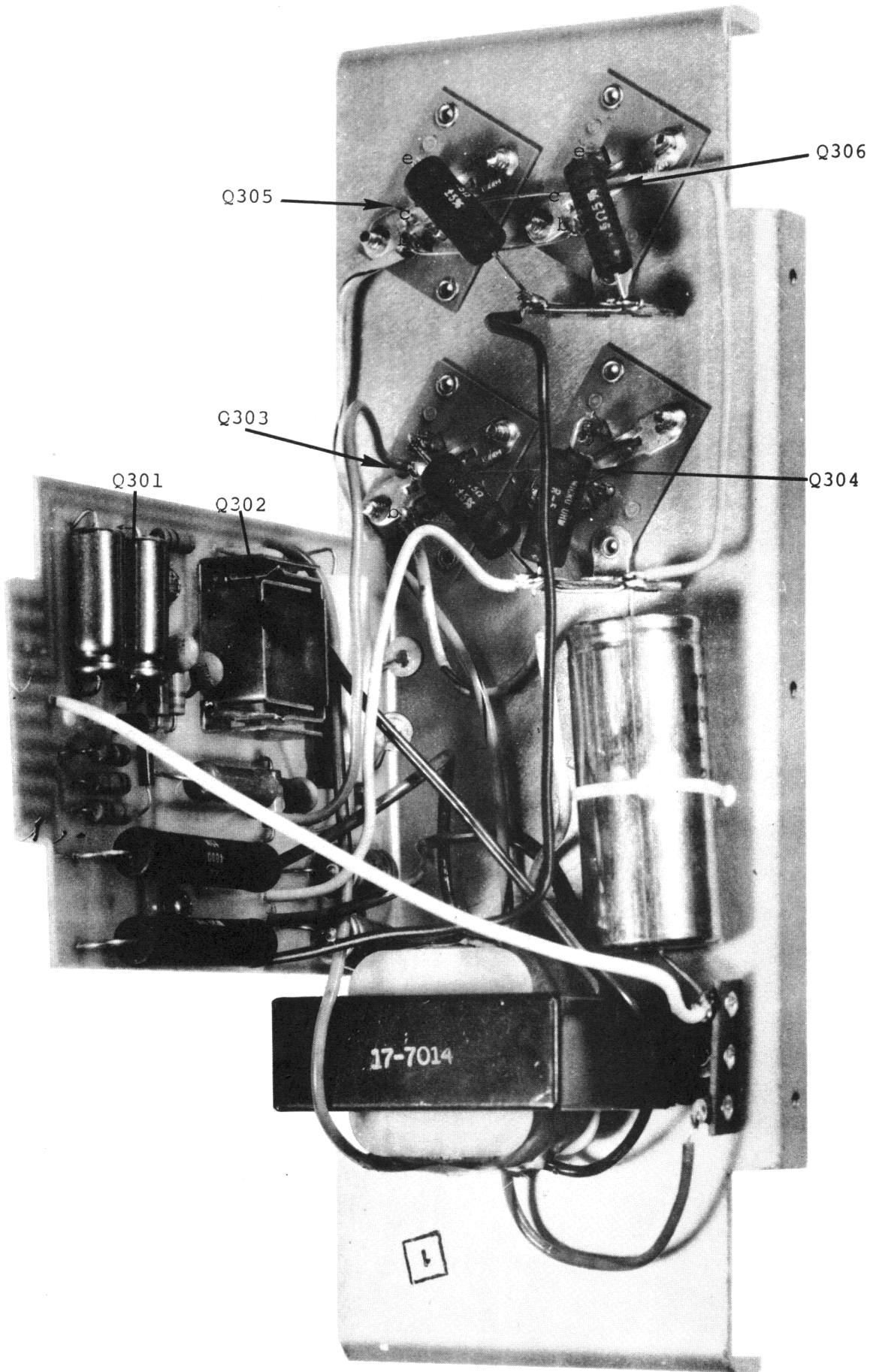

CONTROL LOCATIONS

1. Low Signal Input Jack
2. High Signal Input Jack
3. Bright Switch
4. Volume
5. Treble
6. Bass
7. Reverb
8. Tremolo Rate Control
9. Tremolo Intensity Control
10. Ground Reverse Switch
11. Power Switch
12. Pilot Light
13. Power Cord
14. Fuse
15. AC Receptacle
16. Output Jack
17. Output Jack
18. Booster Jack
19. Footswitch Jack

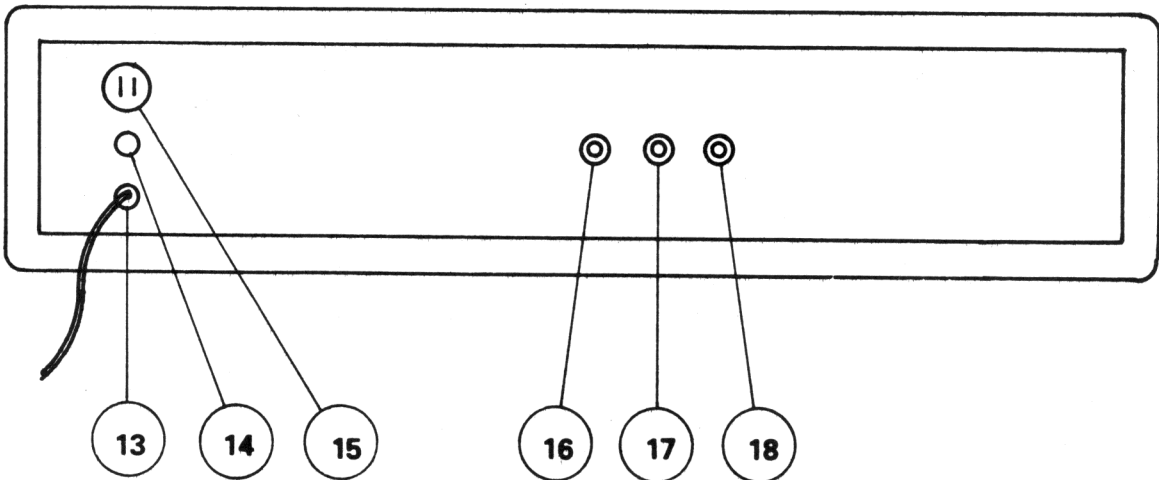
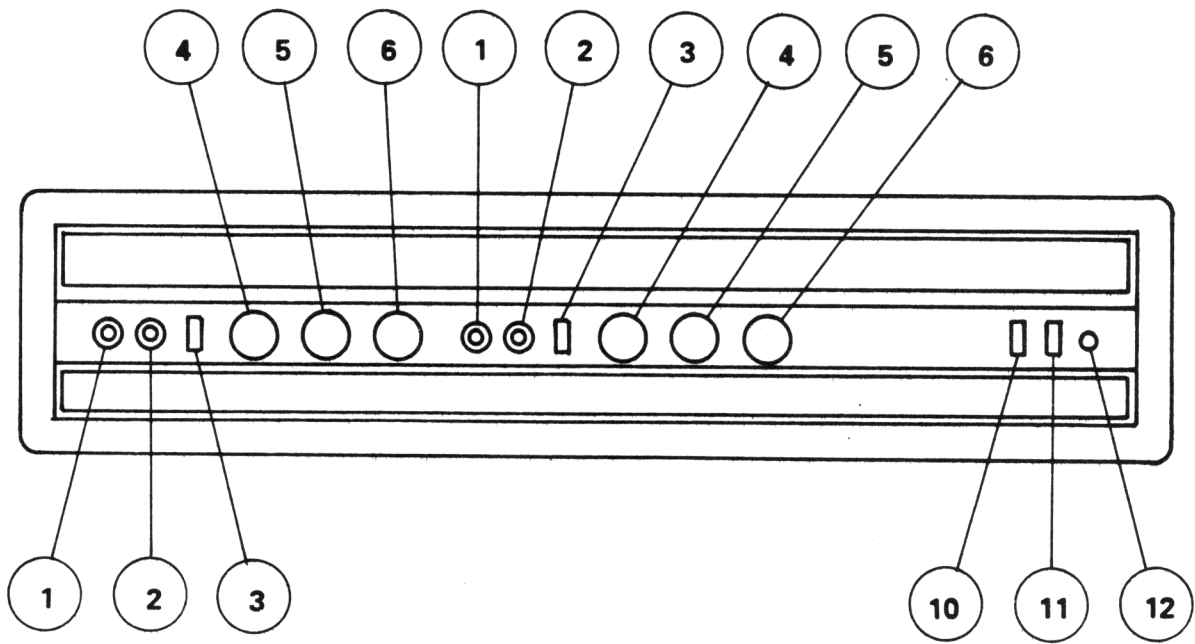

Pages 20-23 inclusive are missing
(Speaker wiring diagrams)

ACOUSTIC CONTROL CORPORATION

Troubleshooting Chart

MODEL 150

Problem	Cause	Suggested Check
Amplifier blows fuses	Short circuit	Wrong size fuse. Possible shorted bridge rectifier or power transformer, shorted power transistors.
After period of operation, amplifier blows fuses or distorts	Output transistors overheating	Possible speaker rubbing. Check audio cables. Check R-404 (22 ohm 1 W resistor) – overheating or disconnection indicates high frequency oscillation. Check R-209, R-308, C-306 or C-302 on PC Board for possible component failure. Check 100 mmf disc across base of Q-103 (MPS A09) and 0.01 mf disc across C-105 (100 mv 50V) on 17-10 PC Board. Check 100 mmf disc base to collector Q-213 and 0.01 mf across 100 mf 50V filter on 17-11 PC Board.
Amplifier distortion at low volume	Excessive crossover distortion	Thermistor values R-316 and R-317 are incorrect speaker, filter cap. Value should be 100 ohm room temperature.
Intermittance or distortion	Component failure	Blown output coupling capacitor. Overheated bias resistor. Broken solder joints of the potentiometers. Check plug in circuit board clips. Half cycle distortion, possible transformer connection broken.
Reverb distorted when reverb control is in full clockwise position	Feedback occurs	Check position of foam pad used to stop shock, located under the reverb tank but may be touching the springs.
No reverb	Reverb shuts off	Check the C215 0.05 mfd disc capacitor located between the reverb and tremolo potentiometers.
Feedback of oscillation from the reverb	Reverb system has more bass than normal	Check 100 mfd capacitor, 18 ohm 1/2 W and 6.8 k ohm 1/2 W resistors on the 17-11 PC Board.

ACOUSTIC CONTROL CORPORATION

Troubleshooting Chart

MODEL 150 – continued

Problem	Cause	Suggested Check
Buzzing sound at all frequencies	Open circuit	Possible broken lead on C-105, C-201 or C-209.
Hum	Ground loop or open ground	Check for loose connection.
Loss of power or bass	One speaker inoperative	Speakers possibly wired out of phase. Note: cone back pressure will move the cone of the unit not working. Speaker shorted Amp-grounding not in phase.
No output on speaker jack #2	Component failure	Check 100 K 1/2 W resistor located between speaker jack #2 and booster jack.

PARTS LIST FOR A MODEL 150

<u>Acoustic Part Number</u>	<u>Part</u>
14-19	Footswitch Cover Plate
14-20	Rubber Foot
14-37	Amp Cabinet
14-38	Chassis
14-39	Side Plate
14-40	Heat Sink
15-1	100 pf Disc.
15-6	0.005 mf Disc.
15-7	0.01 mf Disc.
15-10	0.047 mf Tubular
15-11	0.1 mf Dip
15-13	1.0 mf 35v Tant.
15-14	2.2 mf 35v Tant.
15-16	100 mf 40v Elect.
15-18	470 pf Disc.
15-20	10 mf 50v Elect.
15-21	3900 mf 80v Elect.
15-23	0.0015 mf Disc.
15-27	0.05 mf Disc.
15-32	50 mf 50v Elect.
15-33	24 pf Disc.
15-34	68 pf Disc.
15-36	250 pf 50v Elect.
15-37	500 mf 6v Elect.
15-38	1000 mf 50v Elect.
15-39	1 mf 50v Elect.
17-10	P.C. Board 17-10
17-11	P.C. Board 17-11
17-12	P.C. Board 17-12
18-2	1.5 HY Torroid
21-1	Terminal 2 pt
21-2	Phone Jack — Open
21-3	Phone Jack — Closed
21-5	AC Outlet
21-7	Phono Plug
21-11	Socket
21-13	#10 Crimp Lug
21-17	3 ckt Phone Jack
21-28	PC Connector — 10 pin
21-31	2 ckt Phone Plug
24-2	Knob

<u>Acoustic Part Number</u>	<u>Part</u>
24-5	Faceplate
24-6	Trim Strip
28-4	Clamp – 2"
28-6	PC Brkt – MB128
28-22	Grommet 3/8"
28-23	Swage STandoff 1/4
28-26	Cord Retainer Knob
28-37	Fibre Gasket
28-44	3 Prong Corners
28-45	3/4 x #6 oval hd drive screw
28-46	2 Prong Corners
28-47	Glides, Steel Nickel
28-48	Glides, Steel Nickel
28-59	Sockets for Castors
28-60	Castors
31.5-3	Footswitch Casting 2 hole
31.5-6	Spring Reverb 4c
31-5-13	Chassis Scrnd 150
37-1	Data Cell
39-1	Pilot Light
45-1	Relay
47-1	18 10% 1/2w C.C.
47-1	47 10% 1/2w C.C.
47-1	100 10% 1/2w C.C.
47-1	150 10% 1/2w C.C.
47-1	560 10% 1/2w C.C.
47-1	680 10% 1/2w C.C.
47-1	1k 10% 1/2w C.C.
47-1	1.2k 10% 1/2w C.C.
47-1	1.8K 10% 1/2w C.C.
47-1	2.2k 10% 1/2w C.C.
47-1	4.7k 10% 1/2w C.C.
47-1	6.8k 10% 1/2w C.C.
47-1	8.2k 10% 1/2w C.C.
47-1	10k 10% 1/2w C.C.
47-1	15k 10% 1/2w C.C.
47-1	22k 10% 1/2w C.C.
47-1	33k 10% 1/2w C.C.
47-1	47k 10% 1/2w C.C.
47-1	68k 10% 1/2w C.C.
47-1	100k 10% 1/2w C.C.
47-1	330k 10% 1/2w C.C.
47-1	470k 10% 1/2w C.C.

<u>Acoustic Part Number</u>	<u>Part</u>
47-1	820k 10% 1/2w C.C.
47-1	1m 10% 1/2w C.C.
47-1	1.5m 10% 1/2w C.C.
47-1	2.7m 10% 1/2w C.C.
47-1	6.8m 10% 1/2w C.C.
47-1	56k 10% 1/2w C.C.
47-1	1.2k 10% 1/2w C.C.
47-1	10k 10% 1/2w C.C.
47-1	22k 10% 1/2w C.C.
47-1	47k 10% 1/2w C.C.
47-1	100k 10% 1/2w C.C.
47-2	3.3k 10% 2w C.C.
47-3	560 10% 5w W.W.
47-6	470k 5% 1/2 D.C.
47-6	10m 5% 1/2 D.C.
47-7	0.5 5% 5w W.W.
47-8	400 5% 10w W.W.
47-9	6.8 5% 1/2w C.C.
47-10	22 10% 1w C.C.
47.5-19	50k
47.5-20	100k
47.5-21	500k
47.5-22	1m
48-1	2N4248
48-1	2N4360
48-3	40408 RCA
48-7	40410 RCA
48-13	MPS A09 MOTO
48-15	60085
48-18	MPO 12 HBD
51-1	3 A Rocker Switch
51-3	Fuse Holder
51-8	Push-Push Switch
51-9	3A 3AG Fuse
53-2	Thermister
56-3	XFMR – 150
56-4	Driver XFMR – 150

SPECIFICATIONS

134, 135 and 150 Top

Preamplifier Gain	x80 (high gain input)
Signal-to-noise Ratio	80db
Minimum Input Voltage For Rated Output	21mv
Maximum Input Voltage	1.16 Volts
Power Output Measured Across 3.2 Ohm Load	110 Watts (RMS)
Booster Output Voltage At 100 Watts	230mv
Channels	2
Inputs Per Channel	2(1/4" phone jacks)
Gain Difference Between Inputs	10db
110 Volt AC Outlet	1
Fuse	3 Amp (3A 3AG)

Controls Channel A

Bright/Normal Switch	Rocker Type
Volume	Rotary Potentiometer
Treble	Rotary Potentiometer
Bass	Rotary Potentiometer

Controls Channel B

Bright/Normal Switch	Rocker Type
Volume	Rotary Potentiometer
Treble	Rotary Potentiometer
Bass	Rotary Potentiometer
Reverb	Rotary Potentiometer
Tremolo Speed	Rotary Potentiometer
Tremolo Intensity	Rotary Potentiometer

Power Section Controls

Ground Reverse (GND)	Rocker Type
Power On/Off (PWR)	Rocker Type
Indicator	1 Neon Lamp

154 Speaker Cabinet Specifications

Speaker Complement	6 Eminence 10" Speakers
Cabinet Design	Sealed System
Cabinet Construction	3/4" Braced Plywood
Speaker Access	Removable Speaker Panel
Speaker Panel Access	6 Bolts (1/4-20 Threads)
Speaker Mounting (each speaker)	4 Bolts (10-32 Threads)
Cabinet Size	36" H x 24" W x 12" D
Shipping Weight	85 lbs.

152 Speaker Cabinet Specifications

Speaker Complement	2 Eminence 15" Speakers
Cabinet Design	Sealed System
Cabinet Construction	3/4" Braced Plywood
Speaker Access	Removable Speaker Panel

Speaker Panel Access	6 Bolts (1/4-20 Threads)
Speaker Mounting (each speaker)	4 Bolts (10-32 Threads)
Cabinet Size	36" H x 24" W x 12" D
Shipping Weight	80 lbs.

155 Speaker Cabinet Specifications

Speaker Complement	4 Eminence 12" Speakers
Cabinet Design	Sealed System
Cabinet Construction s.	3/4" Braced Plywood
Speaker Access	Snap-Off Grill Frame
Speaker Mounting (each speaker)	8 Bolts (10-32 Threads)
Cabinet Size	36" H x 28" W x 15" D
Shipping Weight	110 lbs.

134 Speaker Cabinet Specifications

Speaker Complement	2 Oxford 12" Speakers
Cabinet Design	Open Back
Cabinet Construction	3/4" Braced Plywood
Speaker Access	Snap Off Grill Frame
Speaker Mounting	8 Bolts (10-32 Thread)
Cabinet Size	26 1/2" L x 27" H x 11 1/2" D
Shipping Weight	80 lbs.

135 Speaker Cabinet Specifications

Speaker Complement	4 Eminence 10" Speakers
Cabinet Design	Open Back
Cabinet Construction	3/4" Braced Plywood
Speaker Access	Snap Off Grill Frame
Speaker Mounting	4 Bolts (10-32 Threads)
Cabinet Size	26 1/2" L x 21 1/4" H x 11 1/2 D
Shipping Weight	80 lbs.