

HiFi ENGINE®

For more Hi-Fi manuals and set-up information
please visit www.hifiengine.com



ELECTRONICS SERVICE MANUAL

X-10

RECEIVER



TELEDYNE

ACOUSTIC RESEARCH

**330 Turnpike Street, Canton,
Mass. 02021, USA.**

SPECIFICATION

1. Input Sensitivity at 1kHz, 100 watt, 8 ohm	MM	2.5 mV
	MC	200 uV
	High Level	150 mV
2. Input Impedance	MM	47k Ohm/100pF
	MC	100 Ohm/100pF
	High Level	20k Ohm/15opF
3. S/N Ratio (IHF-A)	MM	80 dB
	MC	70 dB
	High Level	90 dB
4. Input Overload (1kHz)	MM	120 mV
	MC	---
	High Level	50 dB (10kHz)
5. Channel Separation	MM	50 dB (1kHz)
	MC	---
	High Level	50 dB (10kHz)
6. Frequency Response	20Hz--20kHz	+0 dB, -0.5 dB
7. RIAA Error	20Hz--20kHz	±0.2 dB
8. TREBLE Maximum Boost at 10 kHz	+8 dB	+8 dB
9. TREBLE Maximum Cut at 10kHz		-8 dB
10. MID RANGE Maximum Boost (1 kHz)		+8 dB
11. MID RANGE Maximum Cut (1 kHz)		-8 dB
12. BASS Maximum Boost at 100 Hz		+8 dB
13. BASS Maximum Cut at 100 Hz		-8 dB
14. Mute attenuation (1 kHz)		-20 dB
15. THD (20Hz--20kHz) from 1 watt to 100 watt, 8 Ohm		0.03 %
16. SMPT IMD from 1 watt to 100 watt, 8 Ohm		0.03 %
17. Continuous Power Output (20Hz-20kHz)	8 Ohm	100 W
	4 Ohm	170 W
18. Dynamic Headroom		2 dB
19. Peak Current Capability		40A
20. Slew Rate Limit		25V/uS
21. high pass filter-3dB Frequency		13Hz/-12dB/OTC
22. Dimensions WxHxD (inch)		16.9x4.35x14.9
	(mm)	430x110x378
23. Net Weight		15kg 33lb

FM TUNER SECTION:

1. Usable sensitivity: (300 Ω)		2.0uV
2. 50dB quieting sensitivity:	Mono/Stereo:	3.2uV/35uV
3. THD @ 65dBf:	Mono/Stereo 100Hz:	0.2%/0.3%
	Mono/Stereo 1 kHz:	0.1%/0.12%
	Mono/Stereo 10kHz:	0.2%/0.3%
4. S/N ratio (A weighted, at 65dBf):	Mono/Stereo:	75dB/70dB
5. HUM and noise @ 65dBf:	/Stereo:	70dB/65dB
6. De-emphasis accuracy:	50us:	\pm 0.5dB
	75us:	0.5dB
7. Capture ratio @ 45dBf:		1.5dB
8. Alternated channel selectivity @ 45dBf:		70dB
9. Spurious response 1/2 IF:		85dB
10. Image rejection:		75dB
11. IF rejection:		110dB
12. AM suppression @ 65dBf:		65dB
13. Stereo seperation:	100Hz:	40dB
	1 kHz:	50dB
	10 kHz:	40dB

AM TUNER SECTION:

1. Usable sensitivity:	25uV
2. Selectivity:	40dB
3. Image rejection:	40dB
4. IF rejection:	50dB
5. AGC:	50dB
6. T.H.D. 400Hz 30% modulation @ 10mV/m:	0.5%
7. Audio bandwidth:	40-3k2Hz
8. S/N @ 10mV/m:	45dB
9. 2nd & 3rd tweet:	3%

1. FM ALIGNMENT: a. SELECTOR SWITCH AT FM POSITION
 b. AC LINE VOLTAGE AT RATED VOLTAGE
 c. MONITOR OUTPUT AT REC OUT

SECTION	FM		SG		DIAL SETTING	INDICATOR	ADJUSTMENT	ADJUST FOR	
	CONNECTION	CARRIER	MOD						
THD	1		98MHz	100% MOD 1KHz	98MHz	DIGITAL VOLTAGE METER	IFT 02 UP SIDE CORE	PIN TP2 VOLTAGE 0±0.05V	
	2					THD METER	IFT 02 DOWN SIDE CORE	MINIMUM THD	
	3					REPEAT STEP 1 AND 2			
RF	1	90MHz	100% MOD 400Hz	90MHz	DIGITAL VOLTAGE METER	L04	PIN TP1 TUNING VOLTAGE 18.7±0.2V		
	2	106MHz		106MHz				TC04	
	3	REPEAT STEP 1 AND 2							
SENS	1	CONNECT TO FM 300 OHM ANTENNA TERMINAL ON THE REAR PANEL THROUGH FM ANTENNA	100% MOD 400Hz	90MHz	VTVM & OSCILLOSCOPE	L01-L03	MAXIMUM OUTPUT		
	2			106MHz				106MHz	
	3			98MHz				98MHz	IFT01
	4			REPEAT STEP 1.2 AND 3					
SIGNAL STRENGTH INDICATOR		98MHz ANT. INPUT LEVEL 60dB	100% MOD 400Hz	98MHz	VTVM & OSCILLOSCOPE	VR201	THE 5th LED JUST dark		
AUTO STOP LEVEL		98MHz ANT. INPUT LEVEL 17dB	100% MOD 400Hz	98MHz	VTVM & OSCILLOSCOPE	VR01	LOCK LED JUST LIGHT		

2. FM MPX ALIGNMENT: a. SELECTOR SWITCH AT FM POSITION
 b. AC LINE VOLTAGE AT RATED VOLTAGE
 c. MONITOR OUTPUT AT REC OUT
 SG AND CONNECTED TO FM 300 OHM ANTENNA TERMINAL ON THE REAR PANEL THROUGH FM DUMMY ANTENNA

SEPERATION	1	98MHz	10% 19KHz (PILOT) L ONLY	98MHz	VTVM & OSCILLOSCOPE TO R REC OUT	VR301	MINIMUM OUTPUT
	2		10% 19KHz (PILOT) R ONLY	98MHz	VTVM & OSCILLOSCOPE TO L REC OUT	VR301	
	3		REPEAT STEP 1 AND 2				

3. AM ALIGNMENT:

SECTION	AM SG			DIAL SETTING	INDICATOR	ADJUSTEMENT	ADJUST FOR
	CONNECTION	CARRIER	MOD				
AM IF	HOT SIDE OF SG OUTPUT THROUGH 200PF TO AM ANT	450KHz	30% MOD	POINT OF NON-INTERFERENCE	VTVM & OSCILLOSCOPE	IFT402	MAXIMUM OUPPUT
AM	HOT SIDE OF SG OUTPUT THROUGH A IOOPANT RADIATE TO AM ANT BAR VERTICALLY AND KEEP 60cm DISTANCE	600KHz	30% MOD 400Hz	600KHz	DIGITAL VOLTAGE METER	IFT401	TUNING VOLTAGE 4.5V±0.2V
RANGE		1400KHz	30% MOD 400Hz	1400KHz		TC401	TUNING VOLTAGE 20.5V+-0.2V
		REPEAT STEP 1 AND STEP 2					
AM		600KHz	30% MOD 400Hz	600KHz	VTVM & OSCILLOSCOPE	IFT403	MAXIMUM OUTPUT
SENS		1400KHz	30% MOD 400Hz	1400KHz		TC402	
		REPEAT STEP 1 AND STEP 2					
SIGNAL STRENGTH INDICATOR		1000KHz SG OUTPUT LEVEL 126dB	30% MOD 400Hz	1000KHz	VTVM & OSCILLOSCOPE	VR401	THE 5th LED JUST dark

4. AMP IDLE CURRENT ALIGNMENT

- a. Remove the load from speaker terminals
- b. Push on POWER for 5 minutes pre-heating
- c. Connect DC millivolt-meter across R533 for left channel R534 for right channel. The meter sensitivity should be set at 100mV full scale deflection
- d. Adjust VR501a (left channel) and VR501b (right channel). Till the meter reading is between 5.0mV and 11.0mV. The alignment is completed.

BLOCK DIAGRAM

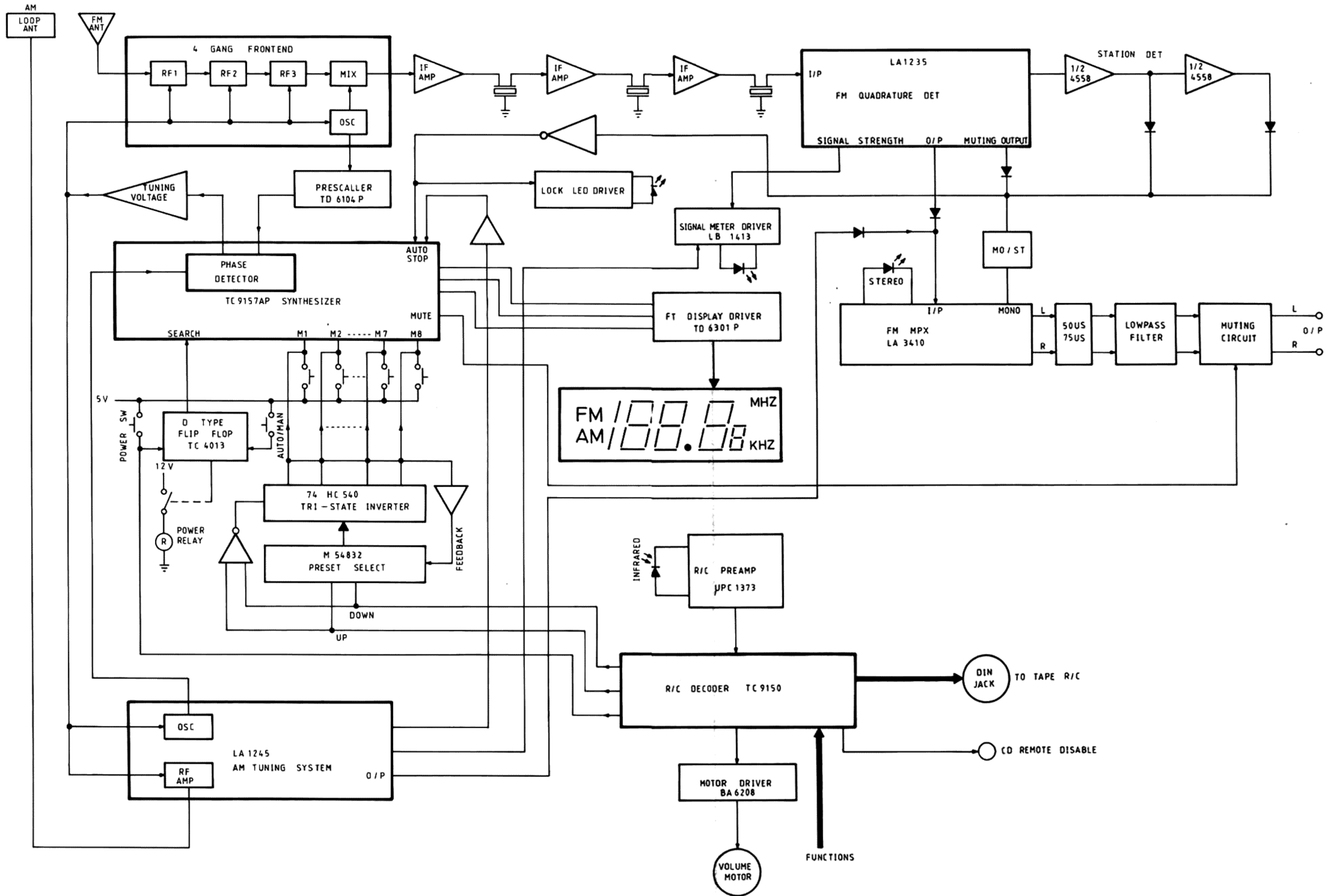

BLOCK DIAGRAM

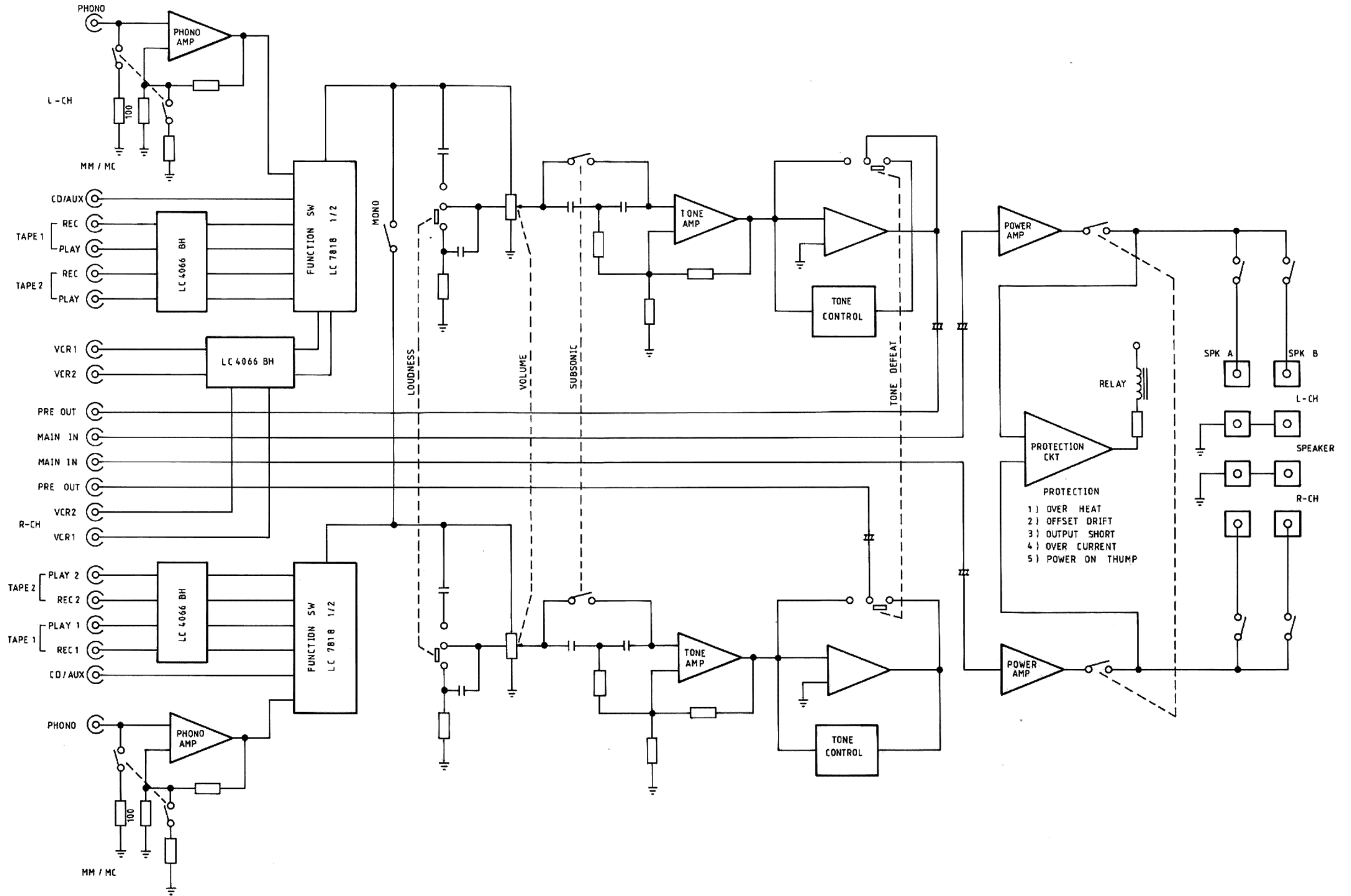

WIRING DIAGRAM

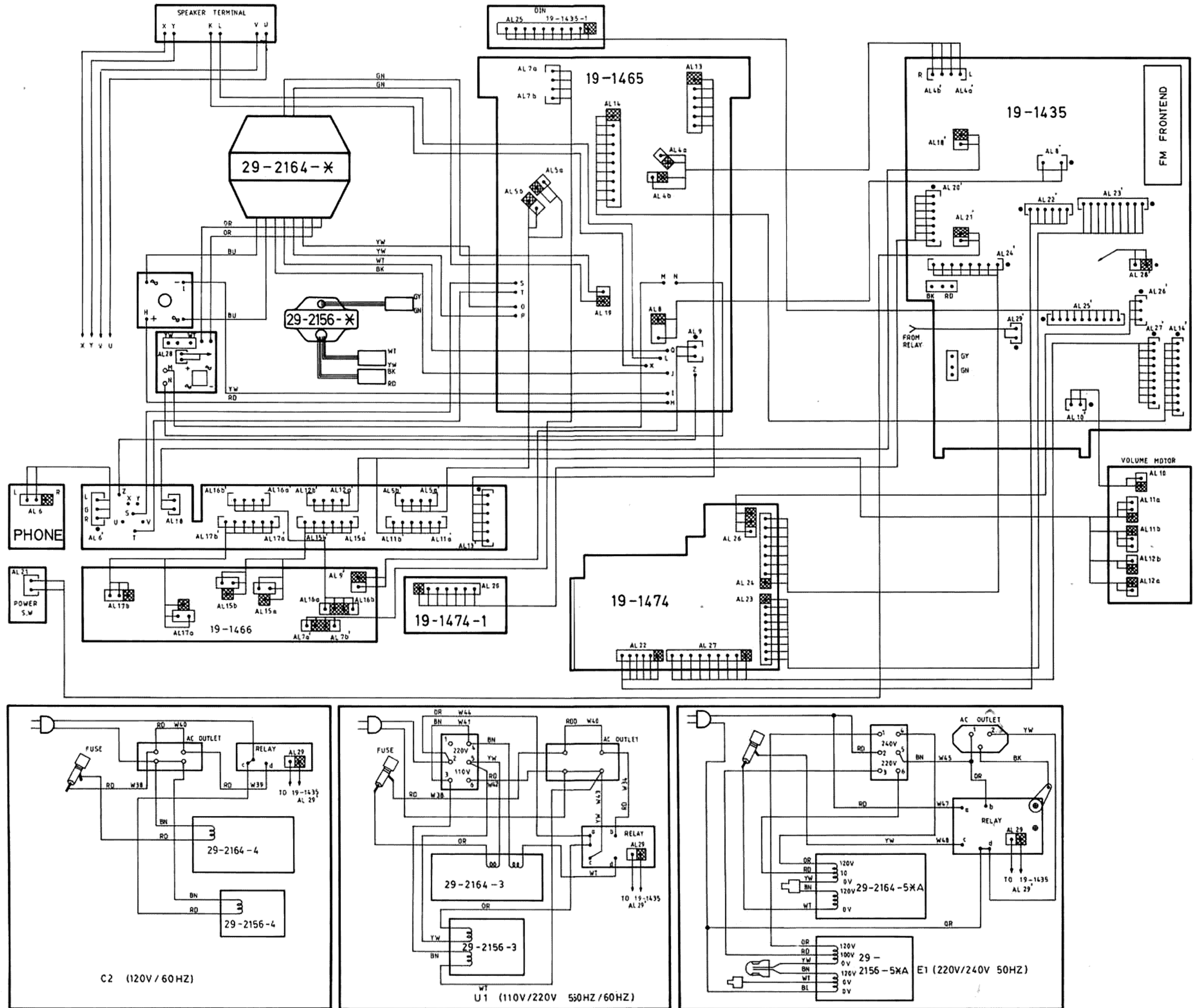

CIRCUIT DIAGRAM

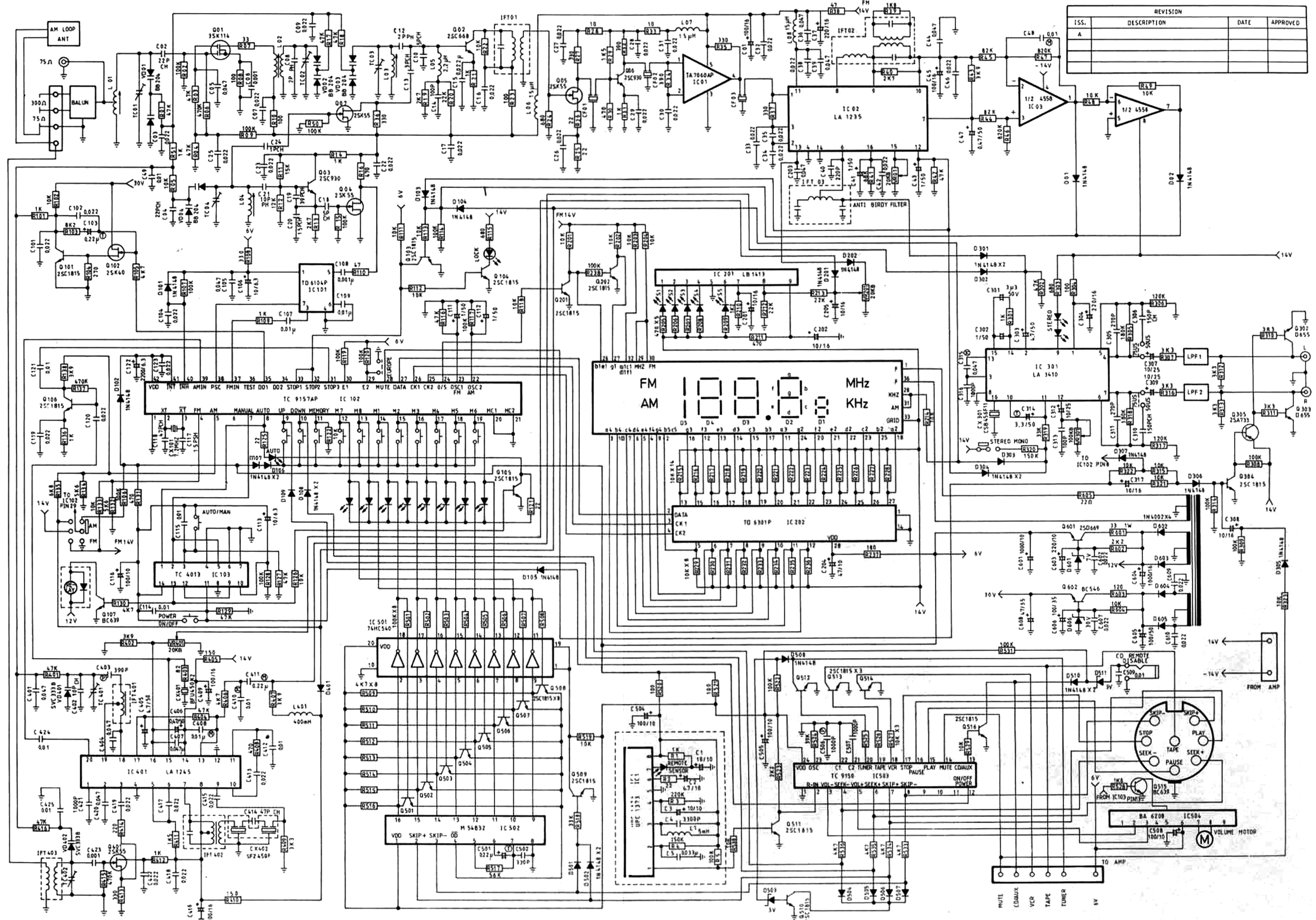

CIRCUIT DIAGRAM

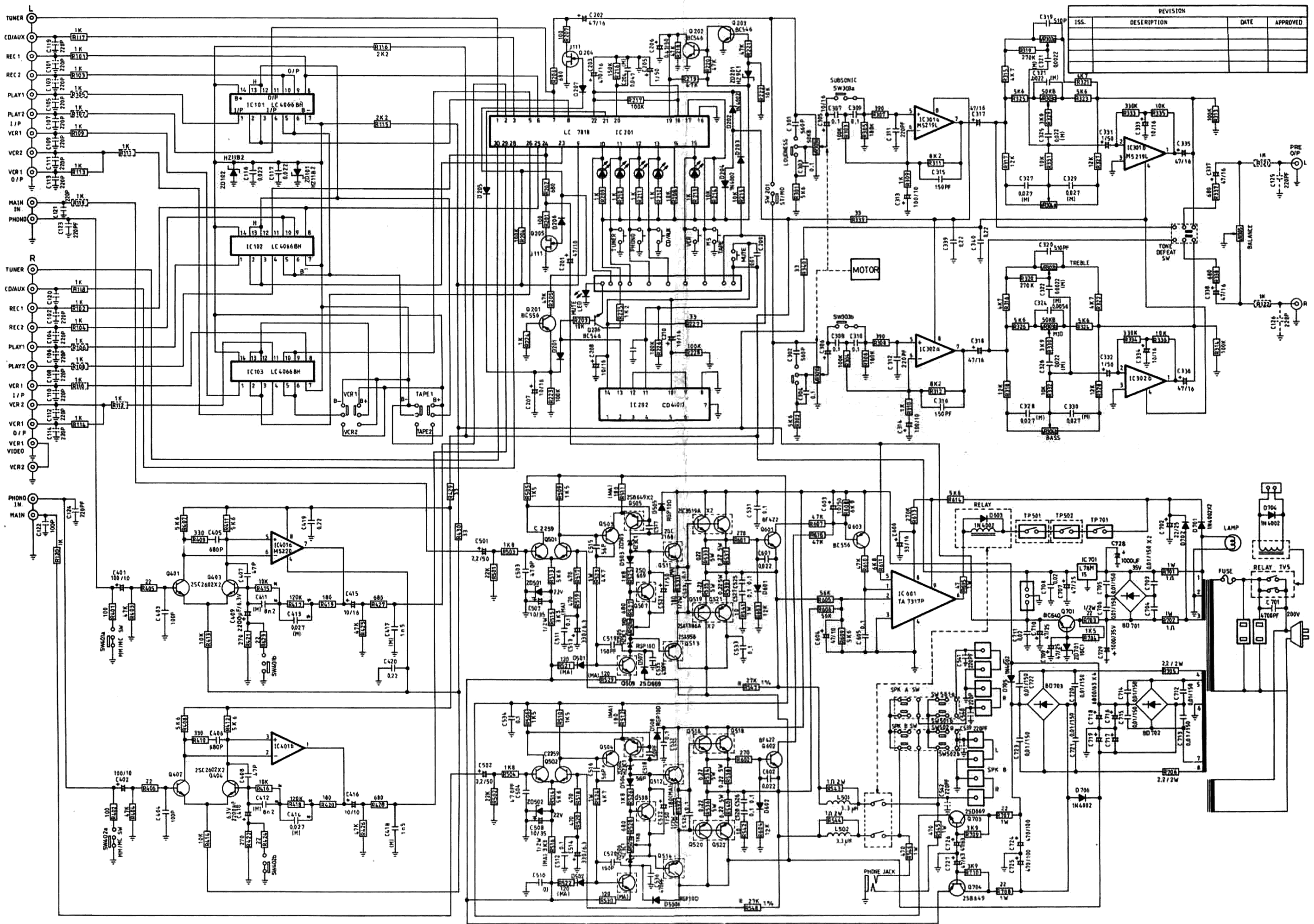

REVISION			
ISS.	DESCRIPTION	DATE	APPROVED

PCB PARTS LOCATIONS (TOP VIEW)

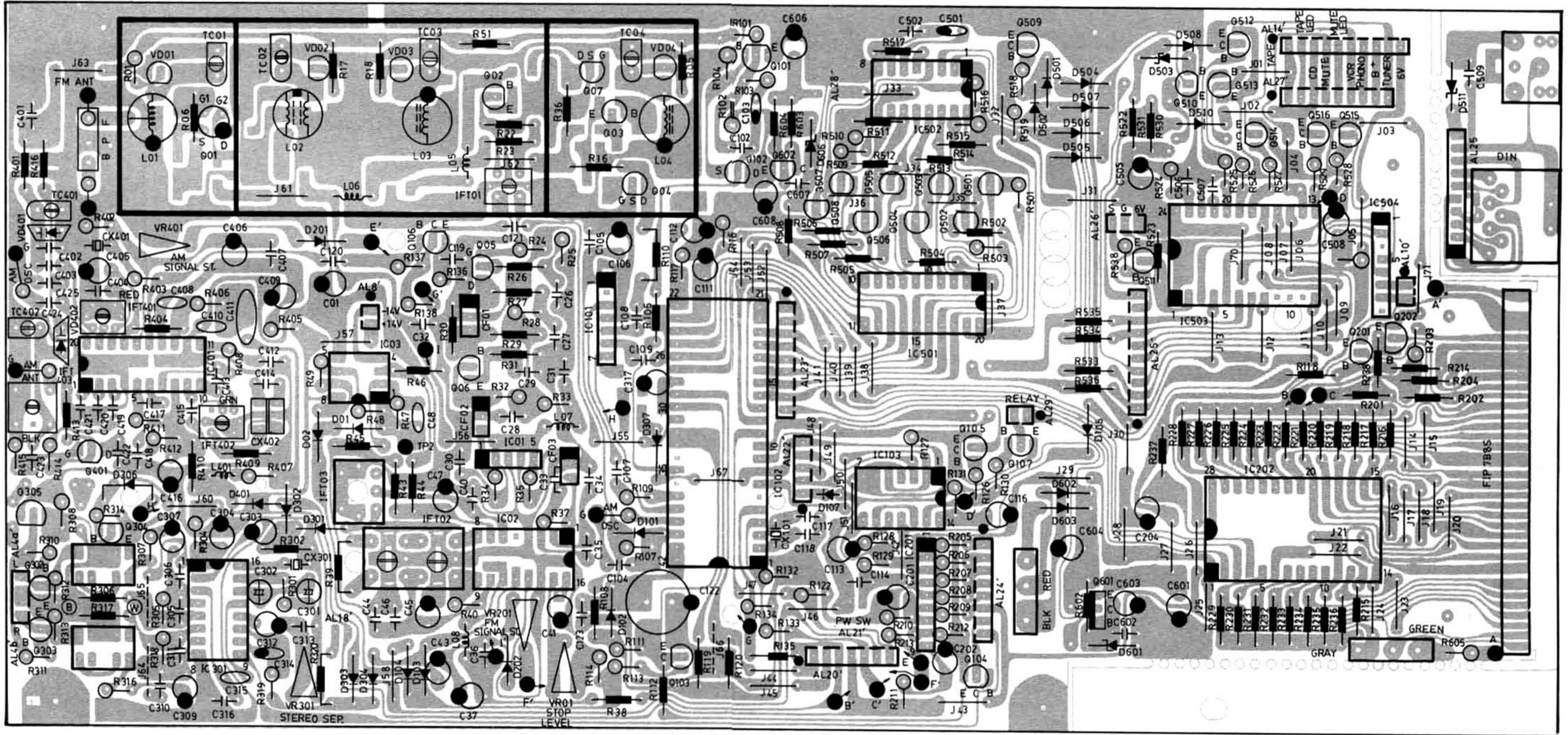

PCB PARTS LOCATIONS (TOP VIEW)

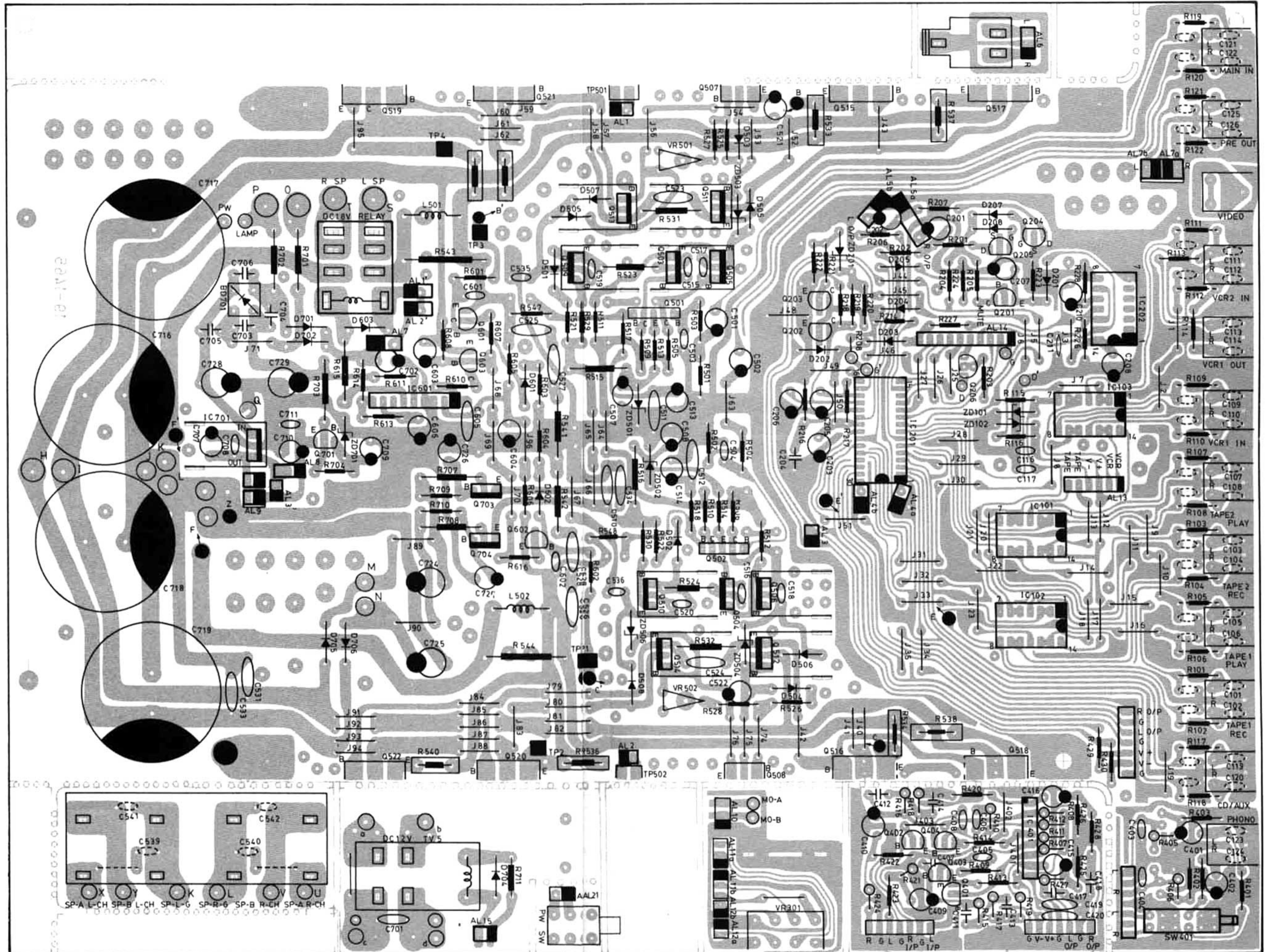

PCB PARTS LOCATIONS (TOP VIEW)

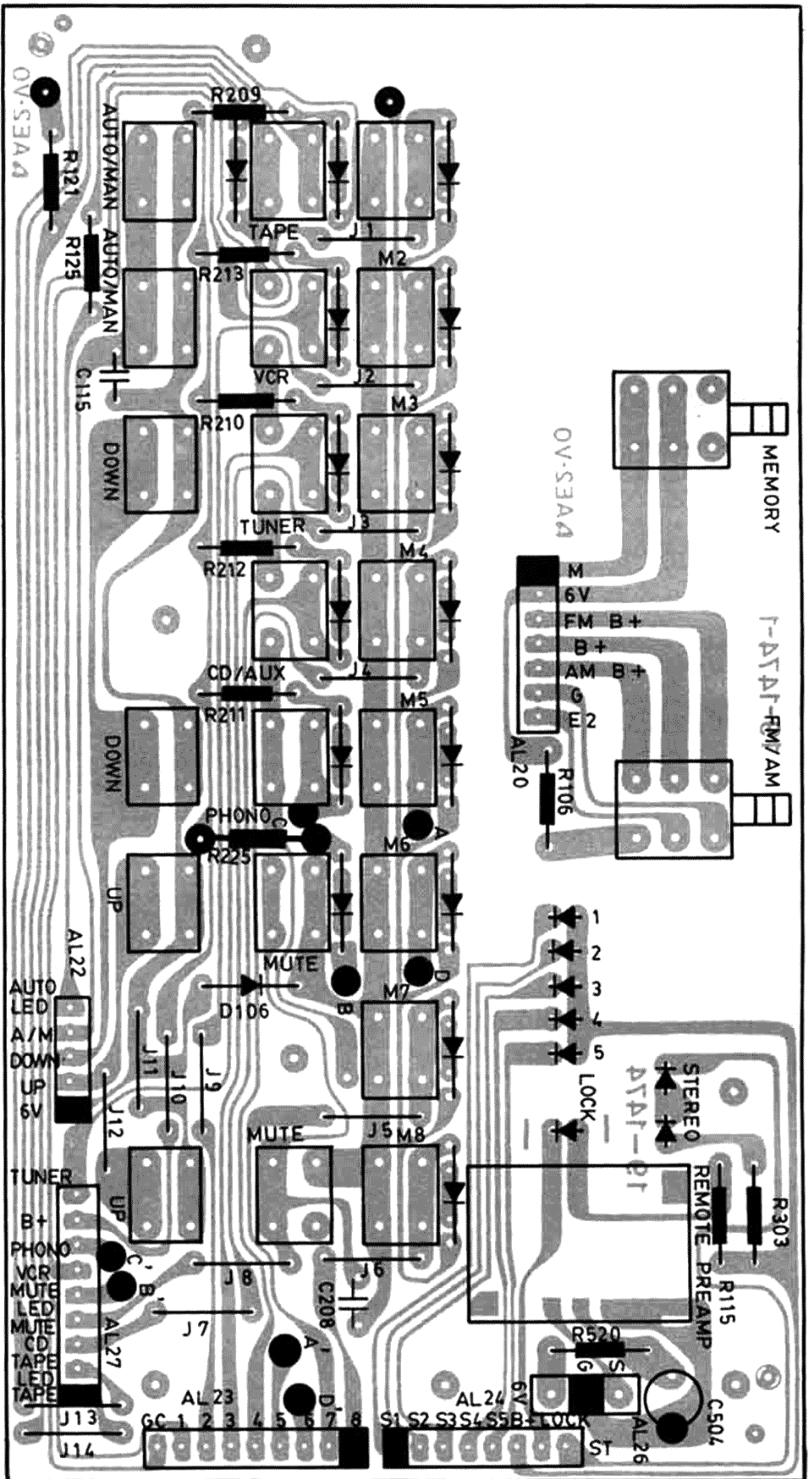

ELECTRICAL PARTS LIST

REF NO.	AR'S PART NO.	DESCRIPTION	MFR'S PART NO.
TUNER RESISTORS			
R01		RES C R 1/4W 47K OHM +-5%	16-1/4CR473J
R02		RES CHIP 1/8W 100K OHM +-5%	16-1/8TY104J
R03-R04		RES CHIP 1/8W 47K OHM +-5%	16-1/8TY473J
R05		RES C A 1/4W 10K OHM +-5%	16-1/4CA103J
R06		RES C R 1/4W 470K OHM +-5%	16-1/4CA474J
R07		RES CHIP 1/8W 33 OHM +-5%	16-1/8TY330J
R08		RES CHIP 1/8W 100 OHM +-5%	16-1/8TY101J
R09		RES CHIP 1/8W 100K OHM +-5%	16-1/8TY104J
R10		RES CHIP 1/8W 100 OHM +-5%	16-1/8TY101J
R11		RES CHIP 1/8W 15K OHM +-5%	16-1/8TY153J
R12		RES CHIP 1/8W 12K OHM +-5%	16-1/8TY123J
R13		RES CHIP 1/8W 2K7 OHM +-5%	16-1/8TY272J
R14		RES CHIP 1/8W 1K OHM +-5%	16-1/8TY102J
R15		RES CHIP 1/8W 100K OHM +-5%	16-1/8TY104J
R16		RES C A 1/4W 470 OHM +-5%	16-1/4CA471J
R17-R18		RES C A 1/4W 47K OHM +-5%	16-1/4CA473J
R19		RES CHIP 1/8W 2K7 OHM +-5%	16-1/8TY272J
R20		RES CHIP 1/8W 22K OHM +-5%	16-1/8TY223J
R21		RES CHIP 1/8W 1K OHM +-5%	16-1/8TY102J
R22		RES C A 1/4W 10K OHM +-5%	16-1/4CA103J
R23		RES C A 1/4W 100 OHM +-5%	16-1/4CA101J
R24		RES C R 1/4W 680 OHM +-5%	16-1/4CR681J
R25-R26		RES C R 1/4W 22 OHM +-5%	16-1/4CR220J
R27		RES C A 1/4W 330 OHM +-5%	16-1/4CA331J
R28		RES C R 1/4W 10 OHM +-5%	16-1/4CR100J
R29		RES C A 1/4W 1K5 OHM +-5%	16-1/4CA152J
R30		RES C A 1/4W 470 OHM +-5%	16-1/4CA471J
R31		RES C A 1/4W 1K OHM +-5%	16-1/4CA102J
R32		RES C R 1/4W 390 OHM +-5%	16-1/4CR391J
R33		RES C R 1/4W 10 OHM +-5%	16-1/4CR100J
R34		RES C R 1/4W 390 OHM +-5%	16-1/4CR391J
R35		RES C R 1/4W 330 OHM +-5%	16-1/4CR331J
R36		RES C A 1/4W 330 OHM +-5%	16-1/4CA331J
R37		RES C R 1/4W 330 OHM +-5%	16-1/4CR331J
R38		RES C A 1/4W 47 OHM +-5%	16-1/4CA470J
R39		RES C A 1/4W 1K8 OHM +-5%	16-1/4CA182J
R40		RES C R 1/4W 2K7 OHM +-5%	16-1/4CR272J
R41		RES CHIP 1/8W 68K OHM +-5%	16-1/8TY683J
R42		RES CHIP 1/8W 47K OHM +-5%	16-1/8TY473J
R43		RES C A 1/4W 3K9 OHM +-5%	16-1/4CA392J
R44-R45		RES C A 1/4W 82K OHM +-5%	16-1/4CA823J
R46		RES C A 1/4W 820K OHM +-5%	16-1/4CA824J
R47		RES C R 1/4W 820K OHM +-5%	16-1/4CR824J
R48-R49		RES C R 1/4W 10K OHM +-5%	16-1/4CR103J
R50		RES CHIP 1/8W 100K OHM +-5%	16-1/8TY104J
R51		RES C A 1/4W 1K OHM +-5%	16-1/4CA102J
R101		RES C R 1/4W 1K OHM +-5%	16-1/4CR102J
R102		RES C R 1/4W 10K OHM +-5%	16-1/4CR103J
R103		RES C R 1/4W 8K2 OHM +-5%	16-1/4CR822J
R104		RES C R 1/4W 270 OHM +-5%	16-1/4CR271J
R105		RES C A 1/4W 4K7 OHM +-5%	16-1/4CA472J
R106		RES C A 1/4W 100K OHM +-5%	16-1/4CA104J
R107		RES C R 1/4W 100K OHM +-5%	16-1/4CR104J
R108		RES C A 1/4W 330 OHM +-5%	16-1/4CA331J
R109		RES C R 1/4W 1K OHM +-5%	16-1/4CR102J
R110		RES C A 1/4W 47 OHM +-5%	16-1/4CA470J
R111		RES C R 1/4W 10K OHM +-5%	16-1/4CR103J
R112		RES C A 1/4W 10K OHM +-5%	16-1/4CA103J
R113		RES C R 1/4W 10K OHM +-5%	16-1/4CR103J
R114		RES C R 1/4W 100K OHM +-5%	16-1/4CR104J
R115		RES C A 1/4W 680 OHM +-5%	16-1/4CA681J
R116		RES C R 1/4W 47K OHM +-5%	16-1/4CR473J
R117		RES C R 1/4W 100K OHM +-5%	16-1/4CR104J
R118		RES C A 1/4W 10K OHM +-5%	16-1/4CA103J
R119-R120		RES C A 1/4W 100K OHM +-5%	16-1/4CA104J
R121		RES C A 1/4W 22 OHM +-5%	16-1/4CA220J

REF NO.	AR'S PART NO.	DESCRIPTION	MFR'S PART NO.
RESISTORS			
R122		RES C R 1/4W 10K OHM +-5%	16-1/4CR103J
R125		RES C A 1/4W 22 OHM +-5%	16-1/4CA220J
R126		RES C R 1/4W 10K OHM +-5%	16-1/4CR103J
R127		RES C R 1/4W 47K OHM +-5%	16-1/4CR473J
R128		RES C R 1/4W 100K OHM +-5%	16-1/4CR104J
R129		RES C R 1/4W 47K OHM +-5%	16-1/4CR473J
R130		RES C R 1/4W 4K7 OHM +-5%	16-1/4CR472J
R131		RES C R 1/4W 470 OHM +-5%	16-1/4CR471J
R132		RES C R 1/4W 5K6 OHM +-5%	16-1/4CR562J
R133		RES C R 1/4W 10K OHM +-5%	16-1/4CR103J
R134		RES C R 1/4W 5K6 OHM +-5%	16-1/4CR562J
R135		RES C A 1/4W 6K8 OHM +-5%	16-1/4CA682J
R136		RES C R 1/4W 1K OHM +-5%	16-1/4CR102J
R137		RES C R 1/4W 470K OHM +-5%	16-1/4CR474J
R138		RES C R 1/4W 3K9 OHM +-5%	16-1/4CR392J
R201-R202		RES C A 1/4W 10K OHM +-5%	16-1/4CA103J
R203-R204		RES C R 1/4W 10K OHM +-5%	16-1/4CR103J
R205-R209		RES C R 1/4W 470 OHM +-5%	16-1/4CR471J
R210		RES C R 1/4W 1K2 OHM +-5%	16-1/4CR122J
R211		RES C R 1/4W 470 OHM +-5%	16-1/4CR471J
R212-R213		RES C R 1/4W 22K OHM +-5%	16-1/4CR223J
R214-R236		RES C A 1/4W 10K OHM +-5%	16-1/4CA103J
R237		RES C A 1/4W 180 OHM +-5%	16-1/4CA181J
R238		RES C A 1/4W 100K OHM +-5%	16-1/4CA104J
R301		RES C R 1/4W 1K OHM +-5%	16-1/4CR102J
R302		RES C A 1/4W 47K OHM +-5%	16-1/4CA473J
R303		RES C A 1/4W 680 OHM +-5%	16-1/4CA681J
R304		RES C R 1/4W 100 OHM +-5%	16-1/4CR101J
R305		RES C R 1/4W 180K OHM +-5%	16-1/4CR184J
R306		RES C A 1/4W 120K OHM +-5%	16-1/4CA124J
R307		RES C R 1/4W 3K3 OHM +-5%	16-1/4CR332J
R308-R309		RES C R 1/4W 100K OHM +-5%	16-1/4CR104J
R310-R313		RES C R 1/4W 3K3 OHM +-5%	16-1/4CR332J
R314		RES C R 1/4W 100K OHM +-5%	16-1/4CR104J
R315		RES CHIP 1/8W 10K OHM +-5%	16-1/8TY103J
R316		RES C R 1/4W 3K3 OHM +-5%	16-1/4CR332J
R317		RES C A 1/4W 120K OHM +-5%	16-1/4CA124J
R318		RES C R 1/4W 180K OHM +-5%	16-1/4CR184J
R319		RES C R 1/4W 33K OHM +-5%	16-1/4CR333J
R320		RES C A 1/4W 150K OHM +-5%	16-1/4CA154J
R321-R322		RES CHIP 1/8W 10K OHM +-5%	16-1/8TY103J
R323		RES C R 1/4W 10K OHM +-5%	16-1/4CR103J
R401		RES C A 1/4W 47K OHM +-5%	16-1/4CA473J
R402		RES C R 1/4W 3K9 OHM +-5%	16-1/4CR392J
R403		RES C R 1/4W 82 OHM +-5%	16-1/4CR820J
R404		RES C A 1/4W 47K OHM +-5%	16-1/4CA473J
R405		RES C R 1/4W 150 OHM +-5%	16-1/4CR151J
R406		RES C R 1/4W 4K7 OHM +-5%	16-1/4CR472J
R407		RES C R 1/4W 39K OHM +-5%	16-1/4CR393J
R408		RES C R 1/4W 470 OHM +-5%	16-1/4CR471J
R409		RES C A 1/4W 3K3 OHM +-5%	16-1/4CA332J
R410		RES C A 1/4W 150 OHM +-5%	16-1/4CA151J
R411		RES C R 1/4W 1K5 OHM +-5%	16-1/4CR152J
R412		RES C R 1/4W 1K OHM +-5%	16-1/4CR102J
R413		RES C A 1/4W 330 OHM +-5%	16-1/4CA331J
R414		RES C R 1/4W 220 OHM +-5%	16-1/4CR221J
R415		RES C R 1/4W 470K OHM +-5%	16-1/4CR474J
R416		RES C A 1/4W 47K OHM +-5%	16-1/4CA473J
R501		RES C R 1/4W 100K OHM +-5%	16-1/4CR104J
R502		RES C A 1/4W 100K OHM +-5%	16-1/4CA104J
R503		RES C R 1/4W 100K OHM +-5%	16-1/4CR104J
R504-R508		RES C A 1/4W 100K OHM +-5%	16-1/4CA104J
R509-R510		RES C R 1/4W 4K7 OHM +-5%	16-1/4CR472J
R511-R514		RES C A 1/4W 4K7 OHM +-5%	16-1/4CA472J
R515-R516		RES C R 1/4W 4K7 OHM +-5%	16-1/4CR472J
R517		RES C A 1/4W 56K OHM +-5%	16-1/4CA563J

REF NO.	AR'S PART NO.	DESCRIPTION	MFR'S PART NO.
RESISTORS			
R518		RES C R 1/4W 33K OHM +-5%	16-1/4CR333J
R519		RES C R 1/4W 10K OHM +-5%	16-1/4CR103J
R520		RES C A 1/4W 100 OHM +-5%	16-1/4CA101J
R521		RES C R 1/4W 100 OHM +-5%	16-1/4CR101J
R522		RES C A 1/4W 100K OHM +-5%	16-1/4CA104J
R523		RES C A 1/4W 2K2 OHM +-5%	16-1/4CA222J
R524		RES C R 1/4W 39K OHM +-5%	16-1/4CR393J
R525-R527		RES C R 1/4W 10K OHM +-5%	16-1/4CR103J
R528		RES C R 1/4W 1K8 OHM +-5%	16-1/4CR182J
R529		RES C R 1/4W 10K OHM +-5%	16-1/4CR103J
R531		RES C A 1/4W 100K OHM +-5%	16-1/4CA104J
R533		RES C A 1/4W 4K7 OHM +-5%	16-1/4CA472J
R534-R536		RES C A 1/4W 4K7 OHM +-5%	16-1/4CA472J
R538		RES C R 1/4W 10K OHM +-5%	16-1/4CR103J
R601		RES NO SMH 1W 33 OHM +-5%	16-1AN330J
R602		RES C A 1/4W 2K2 OHM +-5%	16-1/4CA222J
R603		RES C A 1/4W 120 OHM +-5%	16-1/4CA121J
R604		RES C A 1/4W 10K OHM +-5%	16-1/4CA103J
R605		RES C A 1/4W 22 OHM +-5%	16-1/4CA220J
R1		RES CHIP 1/8W 1K OHM +-5%	16-1/4TY102J
R2		RES CHIP 1/8W 22 OHM +-5%	16-1/4TY220J
R3		RES CHIP 1/8W 220K OHM +-5%	16-1/4TY224J
R4		RES CHIP 1/8W 150K OHM +-5%	16-1/4TY154J
R5		RES CHIP 1/8W 100K OHM +-5%	16-1/4TY104J
VR01		SEMI-FIX 8C 20KB FLAT	VR01-F08203B
VR201		SEMI-FIX 8C 20KB FLAT	VR01-F08203B
VR301		SEMI-FIX 8C 100KB FLAT	VR03-F08104B
VR401		SEMI-FIX 8C 20KB FLAT	VR01-F08203B
CAPACITORS			
C01		CAP EL R 100UF 16V +-20%	17-1.6ER107M
C02		CAP CHIP 22PF 50V +-5% CH	17-5KY220JCH
C03		CAP CHIP 0.022UF 50V +-20%	17-5KY223M
C04		CAP CHIP 22PF 50V +-5% CH	17-5KY220JCH
C05		CAP CHIP 0.047UF 50V +-20%	17-5KY473M
C06		CAP CHIP 1000PF 50V +-10%	17-5KY102K
C07		CAP CHIP 0.022UF 50V +-20%	17-5KY223M
C08		CAP CHIP 2PF 50V +-0.5PF PH	17-5KY2R00PH
C09		CAP CHIP 0.022UF 50V +-20%	17-5KY223M
C10		CAP CER R 5PF 50V +-5% CH	17-5DR5R0DCH
C12		CAP CHIP 2PF 50V +-0.5PF PH	17-5KY2R00PH
C13		CAP CHIP 3PF 50V +-0.5PF PH	17-5KY3R0DCH
C14		CAP CHIP 100PF 50V +-20%	17-5KY101M
C15-C17		CAP CHIP 0.022UF 50V +-20%	17-5KY223M
C18		CAP CER R 5PF 50V +-0.5PF CH	17-5DR5R0DCH
C19		CAP CHIP 39PF 50V +-0.5 CH	17-5KY390JCH
C20		CAP CHIP 15PF 50V +-5% CH	17-5KY150JCH
C21		CAP CHIP 10PF 50V +-5% PH	17-5KY100JPH
C22		CAP CHIP 0.022UF 50V +-20%	17-5KY223M
C23		CAP CHIP 0.022UF 50V +-20%	17-5KY223M
C24		CAP CHIP 1PF 50V +-0.5PF CH	17-5KY1R0DCH
C25		CAP CHIP 0.022UF 50V +-20%	17-5KY223M
C26-C35		CAP CER R 0.022UF 50V +80-20%	17-5DR223Z
C36		CAP CER R 0.047UF 50V +80-20%	17-5DR473Z
C37		CAP EL SM 220UF 16V +50-10%	17-1.6EP2274
C38		CAP CHIP 0.022UF 50V +-20%	17-5KY223M
C39		CAP CHIP 0.047UF 50V +-20%	17-5KY473M
C40		CAP CER R 220PF 50V +-10%	17-5DR221K
C41		CAP EL R 1UF 50V +-20%	17-5ER105M
C42		CAP CHIP 0.022UF 50V +-20%	17-5KY223M
C43		CAP EL R 1UF 50V +-20%	17-5ER105M
C44		CAP CER R 0.047UF 50V +80-20%	17-5DR473Z
C45		CAP EL R 100UF 16V +-20%	17-1.6ER107M
C46		CAP CER 0.022UF 50V +80-20%	17-5DR223Z
C47		CAP EL R 0.47UF 50V +-20%	17-5ER474M
C48		CAP MY R 0.01UF 50V +-5%	17-5FR103J
C49		CAP CER R 0.01UF 50V +-20%	17-5DR103J

REF NO.	AR'S PART NO.	DESCRIPTION	MFR PART
CAPACITORS			
C101		CAP CHIP 0.022UF 50V +-20%	17-5KY
C102		CAP CER R 0.022UF 50V +80-20%	17-5DR
C103		CAP TAS 0.22UF 16V +-20%	17-1.6
C104		CAP CER R 0.022UF 50V +80-20%	17-5DR
C105		CAP CER R 0.047UF 50V +80-20%	17-5DR
C106		CAP EL R 10UF 10V +-20%	17-1ER
C107		CAP CER R 0.01UF 50V +-20%	17-5DR
C108		CAP CER R 0.001UF 50V +80-20%	17-5DR
C109		CAP CER R 0.01UF 50V +-20%	17-5DR
C111-C112		CAP EL R 1UF 50V +-20%	17-5ER
C113		CAP EL R 10UF 10V +-20%	17-1ER
C114-C115		CAP CER R 0.01UF 50V +-20%	17-5DR
C116		CAP EL R 100UF 10V +-20%	17-1ER
C117		CAP CER R 15PF 50V +-10% SH	17-5DR
C118		CAP CER R 47PF 50V +-5%	17-5DR
C119-C120		CAP CER R 0.022UF 50V +80-20%	17-5DR
C121		CAP CER R 0.01UF 50V +-20%	17-5DR
C122		CAP EL SM 2200UF 6.3V +50-10%	17-0.6
C123		CAP CER R 0.022UF 50V +80-20%	17-5DR
C124		CAP CER R 0.01UF 50V +-20%	17-5DR
C201-C202		CAP EL R 10UF 16V +-20%	17-1.6
C203		CAP CHIP 0.047UF 16V +-20%	17-5KY
C204		CAP EL R 47UF 10V +-20%	17-1ER
C205		CAP EL R 22UF 16V +-20%	17-1.6
C301		CAP EL BP 3.3UF 50V +-20%	17-5SR
C302		CAP EL 1UF 50V +-20%	17-5ER
C303		CAP EL R 4.7UF 50V +-20%	17-5ER
C304		CAP EL SM 220UF 16V +50-10%	17-1.6
C305		CAP CER R 270PF 50V +-5% CH	17-5DR
C306		CAP CER R 150PF 50V +-5% CH	17-5DR
C307		CAP EL R 10UF 25V +-20%	17-2.5
C308		CAP EL R 10UF 16V +-20%	17-1.6
C309		CAP EL R 10UF 25V +-20%	17-2.5
C310		CAP CER R 150PF 50V +-5% CH	17-5DR
C311		CAP CER R 270PF 50V +-5% CH	17-5DR
C312		CAP EL R 10UF 25V +-20%	17-2.5
C313		CAP CER R 100PF 50V +-10%	17-5DR
C314		CAP TAS 3.3UF 16V +-20%	17-1.6
C315		CAP MY R 0.047UF 50V +-5%	17-5FR
C316		CAP CER R 0.001UF 50V +80-20%	17-5DR
C317		CAP EL R 10UF 16V +-20%	17-1.6
C401		CAP CER R 0.047UF 50V +80-20%	17-5DR
C402		CAP PS 15PF 50V +-10% CH	17-5DR
C403		CAP PS 390PF 50V +-5%	17-5UJ
C404		CAP CER R 0.047UF 50V +80-20%	17-5DR
C405		CAP EL R 4.7UF 50V +-20%	17-5ER
C406		CAP EL R 0.47UF 50V +-20%	17-5ER
C407		CAP CER R 0.047UF 50V +80-20%	17-5DR
C408		CAP MY R 0.01UF 50V +-5%	17-5FR
C409		CAP EL R 100UF 16V +-20%	17-1.6
C410		CAP MY R 0.01UF 50V +-5%	17-5FR
C411		CAP MY SM 0.22UF 50V +-5%	17-5FP
C412		CAP CER R 0.01UF 50V +-20%	17-5DR
C413		CAP CER R 0.002UF 50V +80-20%	17-5DR
C414		CAP CER R 47PF 50V +-5% CH	17-5DR
C415		CAP CER R 0.022UF 50V +80-20%	17-5DR
C416		CAP EL R 100UF 16V +-20%	17-1.6
C417-C419		CAP CER R 0.022UF 50V +80-20%	17-5DR
C420		CAP CER R 0.047UF 50V +80-20%	17-5DR
C421		CAP CER R 0.001UF 50V +80-20%	17-5DR
C422		CAP CER R 0.022UF 50V +80-20%	17-5DR
C423		CAP CER R 0.001UF 50V +80-20%	17-5DR
C424		CAP CER R 0.01UF 50V +-20%	17-5DR
C501		CAP TAS 0.22UF 16V +-20%	17-1.6
C502		CAP CER R 330PF 50V +-5%	17-5DR
C505		CAP EL R 100UF 10V +-20%	17-1ER

ELECTRICAL PARTS LIST

REF NO.	AR'S PART NO.	DESCRIPTION	MFR'S PART NO.
CAPACITORS			
C506		CAP PS 1000PF 50V +-5%	17-5U102J
C507		CAP CER R 0.001UF 50V +80-20%	17-5DR102Z
C508		CAP EL R 100UF 10V +-20%	17-1ER107M
C601		CAP EL SM 1000UF 16V +50-10%	17-1.6EF108M
C602		CAP CER R 0.022UF 50V +80-20%	17-5DR223Z
C603		CAP EL R 0.001UF 50V +80-20%	17-5DR102Z
C604		CAP EL SM 1000UF 16V +50-10%	17-1.6EF108M
C606		CAP EL SM 1000UF 35V +50-10%	17-3.5EF107M
C607		CAP CER R 0.022UF 50V +80-20%	17-5DR223Z
C608		CAP EL R 47UF 50V +-20%	17-3.5BR476M
TC01-TC04		CAP TRIM CER ECR-HA010A11A	17-1040
TC401-TC402		CAP TRIM CER ECR-HA010A11A	17-1040
C1		CAP EL 10UF 16V +-20%	17-1.6M106M
C2		CAP EL 4.7UF 25V +-20% K	17-2.5M475M
C3		CAP EL 10UF 16V +-20%	17-1.6M106M
C4		CAP MY 3300PF 50V +-5%	17-5P332J
C5		CAP MY 0.033UF 50V +-5%	17-5H333J
DIODES			
D01-D02		DIODE IN4148 A-TYPE	30-1152TA
D101-D106		DIODE IN4148 A-TYPE	30-1152TA
D107		DIODE IN4148	30-1152
D108		DIODE IN4148 A-TYPE	30-1152TA
D109		DIODE IN4148 A-TYPE	30-1152TA
D201-D202		DIODE IN4148 A-TYPE	30-1152TA
D301-D305		DIODE IN4148 A-TYPE	30-1152TA
D306-D307		DIODE IN4148 A-TYPE	30-1152TA
D401		DIODE IN4148 A-TYPE	30-1152TA
D501-D502		DIODE IN4148 A-TYPE	30-1152TA
D503		DIODE ZENER 3V	30-1173-1
D504-D508		DIODE IN4148 A-TYPE	30-1152TA
D510		DIODE IN4148 A-TYPE	30-1152TA
D511		DIODE ZENER 3V	30-1173-1
D601		DIODE ZENER HZ7A-2 26MM	30-1136-1TA
D602-D603		DIODE RECTI 100VIA IN4002	30-1002A
D606		DIODE ZENER HZ30-2 26MM	30-1147-1TA
VD01-VD04		DIODE VARI CAP BB204B	30-1082*A
VD401-VD402		DIODE VARI CAP SVC333B	30-1146
TRANSISTORS			
Q01		FET MOS 3SK114-0	30-2379
Q02		TR 2SC668E/2SC2787K	30-2239-1
Q03		TR 2SC930C	30-2019
Q04-Q05		FET 2SK55D	30-2298
Q06		TR 2SC930C	30-2019
Q07		FET 2SK55D	30-2298
Q101		TR 2SC1815GR	30-2156
Q102		FET 2SK40C	30-2161
Q103-Q106		TR 2SC1815GR	30-2156
Q107		TR BC639	30-2353
Q201-Q202		TR 2SC1815GR	30-2156
Q302-Q303		TR 2SD655E	30-2359
Q304		TR 2SC1815GR	30-2156
Q305		TR 2SA733P	30-2171
Q401		FET 2SK55D	30-2298
Q501-Q514		TR 2SC1815GR	30-2156
Q515		TR BC639	30-2353
Q516		TR 2SC1815GR	30-2156
Q601		TR 2SD669	30-2260
Q602		TR BC546	30-2090
INTEGRATED CIRCUITS			
IC01		IC HA1211/TA7060P&AP 8P	30-3035
IC02		IC FM IF SYSTEM LA1235 16P	30-3206
IC03		IC DUAL OP RC4558/LPC4558N 8P	30-3069
IC101		IC FM PRESCALER TD6104P 7P	30-3149
IC102		IC SYNTHESIZER TC9157AP 42P	30-3342
IC103		IC D-TYPE F/F CD 4013B 14P	30-3008
IC201		IC METER DRIVER CIC6125E 9P	30-3309

REF NO.	AR'S PART NO.	DESCRIPTION	MFR'S PART NO.
INTEGRATED CIRCUITS			
IC202		IC DISPLAY DRIVE ID6301P 28P	30-3150
IC301		IC FM MPX SYSTEM LA3410 16P	30-3346
IC401		IC AM LA1245 20P	30-3195
IC501		IC 74HC540 OCTAL INVERTER	30-3438
IC502		IC M54832P 8-CHANNEL 16P	30-3437
IC503		IC TC9150P REMOTE RECEIVER 24P	30-3435
IC504		IC MOTOR DRIVER BA6208 9P	30-3357
IC1		IC IR PREAMP UPC1373H 8P	30-3337
MISCELLANEOUS			
XC101		XTAL 7.20MHz	30-4004
XC301		CERAMIC RESONATOR CSB456F11	29-3212
XC401		CER FILTER BFU450K2	29-3123
XC402		CF AM SFZ450F	29-3154
LO1		COIL VARI 23PF +-6% 100MHZ	29-1098*A
LO2		COIL VARI 43PF +-6% 100MHZ	29-1267
LO3		COIL VARI 23PF +-6% 100MHZ	29-1101-1
LO4		COIL VARI 30PF +-6% 100MHZ	29-1101*B
LO5		COIL PEAKING RS 2.2UH +-10%	CP-0910RS2R2K
LO6-LO8		COIL PEAKING RL 15UH +-10%	CP-1011RL150K
L401		COIL CHOCK 400MH +-5%	29-1246
IPT01		IPT FM 119AC-AP178W/41K7H5	29-3111
IPT02		IPT FM IF DET L16-400-1182	29-3190
IPT401		IPT AM OSC 7BR-BP119Y	29-3109
IPT402		IPT AM 7MCS-MP257N	29-3169
LPF1-LPF2		LPF FM MPX LA1196	29-3049
CF01-CF03		CF FM SFB10.7ML-A	29-3044-1
IPT403		COIL AM RP	29-1284
		TUBE FL DISPLAY FIP7B8S	31-3026
AMPLIFIER RESISTORS			
R101-R104		RES CA 1/4W 1K OHM +-5%	16-1/4CA102J
R109		RES CA 1/4W 1K OHM +-5%	16-1/4CA102J
R113-R114		RES CA 1/4W 1K OHM +-5%	16-1/4CA102J
R117-R118		RES CA 1/4W 1K OHM +-5%	16-1/4CA102J
R120		RES CA 1/4W 1K OHM +-5%	16-1/4CA102J
R201		RES CA 1/4W 100 OHM +-5%	16-1/4CA101J
R202		RES CA 1/4W 680 OHM +-5%	16-1/4CA681J
R203		RES CA 1/4W 10K OHM +-5%	16-1/4CA103J
R204		RES CA 1/4W 100K OHM +-5%	16-1/4CA104J
R205		RES CA 1/4W 47K OHM +-5%	16-1/4CA473J
R206		RES CA 1/4W 680 OHM +-5%	16-1/4CA681J
R207		RES CA 1/4W 100 OHM +-5%	16-1/4CA101J
R208		RES CR 1/4W 10K OHM +-5%	16-1/4CR103J
R209-R213		RES CA 1/4W 1K OHM +-5%	16-1/4CA102J
R214-R215		RES CA 1/4W 10K OHM +-5%	16-1/4CA103J
R216		RES CA 1/4W 150K OHM +-5%	16-1/4CA154J
R217		RES CA 1/4W 100K OHM +-5%	16-1/4CA104J
R218-R221		RES CA 1/4W 47K OHM +-5%	16-1/4CA473J
R222		RES CA 1/4W 10K OHM +-5%	16-1/4CA103J
R223		RES CA 1/4W 100K OHM +-5%	16-1/4CA104J
R224		RES CR 1/4W 1K OHM +-5%	16-1/4CA102J
R225		RES CA 1/4W 1K2 OHM +-5%	16-1/4CA122J
R226		RES CA 1/4W 100K OHM +-5%	16-1/4CA104J
R227		RES CA 1/4W 33 OHM +-5%	16-1/4CA330J
R228		RES CA 1/4W 100K OHM +-5%	16-1/4CA104J
R301-R302		RES CA 1/4W 5K6 OHM +-5%	16-1/4CA562J
R303-R304		RES CA 1/4W 100K OHM +-5%	16-1/4CR104J
R305-R306		RES CR 1/4W 180K OHM +-5%	16-1/4CR184J
R307-R308		RES CR 1/4W 390 OHM +-5%	16-1/4CR391J
R309-R310		RES CA 1/4W 1K OHM +-5%	16-1/4CA102J
R311-R312		RES CA 1/4W 8K2 OHM +-5%	16-1/4CA822J
R313-R314		RES CA 1/4W 100K OHM +-5%	16-1/4CA104J
R315		RES CA 1/4W 4K7 OHM +-5%	16-1/4CA472J
R316		RES CR 1/4W 4K7 OHM +-5%	16-1/4CR472J
R317-R318		RES CA 1/4W 12K OHM +-5%	16-1/4CA123J
R319		RES CR 1/4W 270K OHM +-5%	16-1/4CR274J
R320		RES CA 1/4W 270K OHM +-5%	16-1/4CA274J

REF NO.	AR'S PART NO.	DESCRIPTION	MFR'S PART NO.
RESISTORS			
R321		RES CA 1/4W 4X7 OHM +-5%	16-1/4CA472J
R322		RES CR 1/4W 4X7 OHM +-5%	16-1/4CR472J
R323		RES CR 1/4W 5K6 OHM +-5%	16-1/4CR562J
R324		RES CA 1/4W 5K6 OHM +-5%	16-1/4CA562J
R325		RES CR 1/4W 5K6 OHM +-5%	16-1/4CR562J
R326		RES CA 1/4W 5K6 OHM +-5%	16-1/4CA562J
R327-R328		RES CA 1/4W 12K OHM +-5%	16-1/4CA123J
R329-R330		RES CR 1/4W 3K9 OHM +-5%	16-1/4CR392J
R331-R332		RES CA 1/4W 10K OHM +-5%	16-1/4CA103J
R333-R334		RES CR 1/4W 330K OHM +-5%	16-1/4CR334J
R335-R336		RES CR 1/4W 10K OHM +-5%	16-1/4CR103J
R337-R338		RES CA 1/4W 680 OHM +-5%	16-1/4CA681J
R339-R340		RES CA 1/4W 33 OHM +-5%	16-1/4CA330J
R401-R402		RES CA 1/4W 100 OHM +-5%	16-1/4CA101J
R403-R404		RES CA 1/4W 47K OHM +-5%	16-1/4CA473J
R405-R406		RES CA 1/4W 22 OHM +-5%	16-1/4CA220J
R407		RES CR 1/4W 2K7 OHM +-5%	16-1/4CR272J
R408		RES CR 1/4W 5K6 OHM +-5%	16-1/4CR562J
R409		RES CA 1/4W 330 OHM +-5%	16-1/4CA330J
R410		RES CR 1/4W 330 OHM +-5%	16-1/4CR330J
R411		RES CR 1/4W 2K7 OHM +-5%	16-1/4CR272J
R412		RES CR 1/4W 5K6 OHM +-5%	16-1/4CR562J
R413-R414		RES CA 1/4W 27K OHM +-5%	16-1/4CA273J
R415-R416		RES CR 1/4W 10K OHM +-5%	16-1/4CR103J
R417-R418		RES CR 1/4W 120K OHM +-5%	16-1/4CR124J
R419		RES CR 1/4W 180 OHM +-5%	16-1/4CR181J
R420		RES CA 1/4W 180 OHM +-5%	16-1/4CA181J
R421		RES CR 1/4W 270 OHM +-5%	16-1/4CR271J
R422		RES CA 1/4W 270 OHM +-5%	16-1/4CA271J
R423		RES CA 1/4W 22 OHM +-5%	16-1/4CA220J
R424		RES CR 1/4W 22 OHM +-5%	16-1/4CR220J
R425-R426		RES CA 1/4W 47K OHM +-5%	16-1/4CA473J
R427		RES CR 1/4W 680 OHM +-5%	16-1/4CR681J
R428		RES CA 1/4W 680 OHM +-5%	16-1/4CA681J
R429-R430		RES CA 1/4W 33 OHM +-5%	16-1/4CA330J
R501-R502		RES CA 1/4W 1K8 OHM +-5%	16-1/4CA223J
R503-R504		RES CA 1/4W 1K5 OHM +-5%	16-1/4CA182J
R505-R506		RES CA 1/4W 1K5 OHM +-5%	16-1/4CA152J
R509-R510		RES CA 1/4W 1K5 OHM +-5%	16-1/4CA152J
R511-R512		RES CA 1/4W 180 OHM +-5%	16-1/4CA181J
R513-R514		RES CA 1/4W 5K6 OHM +-5%	16-1/4CA562J
R515-R516		RES CA 1/4W 3K3 OHM +-5%	16-1/4CA332J
R517-R520		RES CA 1/4W 470 OHM +-5%	16-1/4CA471J
R521-R522		RES CA 1/4W 120 OHM +-5%	16-1/4CA121J
R523-R524		RES CA 1/4W 4K7 OHM +-5%	16-1A472J
R525-R526		RES CA 1/4W 1K8 OHM +-5%	16-1/4CA182J
R527-R528		RES CA 1/4W 680 OHM +-5%	16-1/4CA681J
R529-R530		RES CA 1/4W 120 OHM +-5%	16-1/4CA121J
R531-R532		RES CA 1/2W 180 OHM +-5%	16-1/4CA181J
R533-R540		RES CA 5W 0.22 OHM +-5%	16-1003
R541-R542		RES CA 1W 10 OHM +-5%	16-1A100J
R543-R544		RES CA 2W 1 OHM +-5%	16-2A100J
R545-R546		RES CA 1W 470 OHM +-5%	16-1A471J
R547-R548		RES CA 1/4W 27K OHM +-5%	16-1/4CA273J
R601-R602		RES CA 1/4W 270 OHM +-5%	16-1/4CA271J
R603-R604		RES CA 1/4W 12K OHM +-5%	16-1/4CA123J
R605-R606		RES CA 1/4W 56K OHM +-5%	16-1/4CA563J
R607		RES CA 1/4W 47K OHM +-5%	16-1/4CA473J
R608		RES CA 1/4W 6K8 OHM +-5%	16-1/4CA682J
R609		RES CA 1/4W 5K6 OHM +-5%	16-1/4CA562J
R610		RES CA 1/4W 47K OHM +-5%	16-1/4CA473J
R611		RES CA 1/4W 6K8 OHM +-5%	16-1/4CA682J
R613-R614		RES CA 1/4W 270K OHM +-5%	16-1/4CA274J
R614		RES CA 1/4W 5K6 OHM +-5%	16-1/4CA562J
R615		RES CA 1W 47 OHM +-5%	16-1A470J
R616		RES CA 1/4W 47K OHM +-5%	16-1/4CA473J

REF NO.	AR'S PART NO.	DESCRIPTION	MFR'S PART NO.
RESISTORS			
R701-R702		RES CA 1W 1 OHM +-5%	16-1A100J
R703		RES CA 1/2W 22 OHM +-5%	16-1/2CA220J
R704		RES CA 1/4W 1K5 OHM +-5%	16-1/4CA152J
R705-R706		RES CA 2W 2.2 OHM +-5%	16-2A2R2J
R707-R708		RES CA 1W 22 OHM +-5%	16-1A220J
R709-R710		RES CA 1/4W 3K9 OHM +-5%	16-1/4CA392J
CAPACITORS			
C116-C117		CER R 0.022UF 50V +80-20%	17-5DR223Z
C121		CER R 220PF 50V +-5% SL	17-5DR221JSL
C122		CER R 100PF 50V +-5% SL	17-5DR101JSL
C123-C124		CER R 220PF 50V +-5% SL	17-5DR221JSL
C201		EL R 47UF 10V +-20%	17-1ER476M
C202		EL R 47UF 16V +-20%	17-1.6ER476M
C203		EL R 470UF 16V +-20%	17-1.6ER477M
C204		CER R 0.047UF 50V +80-20%	17-5DR473Z
C205		EL R 1UF 50V +-20%	17-5ER105M
C206		EL R 0.47UF 50V +-20%	17-5ER475M
C207-C208		EL R 10UF 16V +-20%	17-1.6ER106M
C209		CER R 0.01UF 50V +-20%	17-5DR103M
C210		EL R 10UF 16V +-20%	17-1.6ER106M
C211		CER R 0.022UF 50V +80-20%	17-5DR223Z
C301-C302		CER R 560PF 50V +-10%	17-5DR561K
C303-C304		CER R 0.1UF 50V +80-20%	17-1.6ER106M
C307-C310		CER R 0.1UF 50V +80-20%	17-5DR104Z
C311-C312		CER R 220PF 50V +-5%	17-5DR221JSL
C313-C314		EL R 100UF 10V +-20%	17-1ER107M
C315-C316		CER R 150PF 50V +-5% SL	17-5DR151JSL
C317-C318		EL R 47UF 16V +-20%	17-1.6ER476M
C319-C320		CER 510PF 50V +-5%	17-5DR511J
C321-C322		MY R 2200PF 50V +-5%	17-5FR222J
C323-C324		MY R 5600PF 50V +-5%	17-5FR562J
C325-C326		MY R 0.022UF 50V +-5%	17-5FR223J
C327-C330		MY R 0.027UF 50V +-5%	17-5FR273J
C331-C332		EL R 1UF 50V +-20%	17-5ER105M
C333-C334		EL R 10UF 16V +-20%	17-1.6ER106M
C335-C338		EL R 47UF 16V +-20%	17-1.6ER476M
C339-C340		SCER SM 0.22UF 25V +80-20%	17-2.5WR224Z
C401-C402		EL R 100UF 10V +-20%	17-1ER107M
C403-C404		CER R 100PF 50V +-5% SL	17-5DR101JSL
C405-C406		CER R 680PF 50V +-10%	17-5DR681K
C407-C408		CER R 47PF 50V +-5% SL	17-5DR470JSL
C409-C410		EL R 2200UF 6.3V +-20%	17-0.63ER228M
C411-C412		MY R 8200PF 50V +-5%	17-5FR822J
C413-C414		MY R 0.027UF 50V +-5%	17-5FR273J
C415		EL R 10UF 16V +-20%	17-1.6ER106M
C416		EL R 10UF 10V +-20%	17-1ER106M
C417-C418		MY R 1500PF 25V +-5%	17-5FR152J
C419-C420		SCER SM 0.22UF 50V +80-20%	17-2.5WR224Z
C501-C502		EL R 2.2UF 50V +-20%	17-5ER225M
C503-C504		CER R 470PF 50V +-5% SL	17-5DR471JSL
C507-C508		EL R 10UF 35V +-20%	17-3.5ER106M
C510-C512		CER R 0.1UF 50V +80-20%	17-5DR104Z
C513-C514		EL R 330UF 6.3V +-20%	17-0.6ER337M
C515-C518		CER R 56PF 50V +-5% SL	17-5DR560JSL
C519-C520		CER R 150PF 50V +-5% SL	17-5DR151JSL
C521-C522		EL R 1UF 50V +-20%	17-5FR105M
C523-C528		CER R 0.1UF 50V +80-20%	17-5DR104Z
C531-C534		CER R 0.1UF 50V +80-20%	17-5DR104Z
C535-C536		CER R 470PF 50V +-5% SL	17-5DR471JSL
C539-C542		CER R 220PF 50V +-5% SL	17-5DR221JSL
C601-C602		CER R 0.022UF 50V +80-20%	17-5DR223Z
C603		EL R 10UF 50V +-20%	17-5ER106M
C604		EL R 47UF 10V +-20%	17-1ER476M
C605		CER R 0.1UF 50V +80-20%	17-5DR104Z
C606		EL R 33UF 16V +-20%	17-1.6ER336M
C702		EL R 22UF 25V +-20%	17-2.5ER226M

ELECTRICAL PARTS LIST

REF NO.	AR'S PART NO.	DESCRIPTION	MFR'S PART NO.
CAPACITORS			
C703-C706		MY R 0.01UF 150V +-5%	17-15FR103J
C707		EL R 47UF 25V +-20%	17-2.5ER476M
C708		CER R 0.022UF 50V +80-20%	17-5DR223Z
C709-C710		EL R 47UF 25V +-20%	17-2.5ER476M
C711		CER R 0.022UF 50V +80-20%	17-5DR223Z
C712-C715		MY R 0.01UF 150V +-5%	17-15FR103J
C716-C719		EL R 6800UF 63V +-20%	17-6.3ER688M
C720-C723		MY R 0.01UF 50V +-5%	17-15FR103J
C724-C725		EL R 470UF 100V +-20%	17-10ER477M
C726-C727		EL R 47UF 63V +-20%	17-6.3ER476M
C728-C729		EL R 1000UF 35V +-20%	17-3.5ER108M
DIODE			
D201		IN4148 A-TYPE	30-1152TA
D202		RECTI 100VIA IN4002/1001	30-1102
D203		IN4148 A-TYPE	30-1152TA
D205-D207		IN4148 A-TYPE	30-1152TA
D501-D504		IN4148 A-TYPE	30-1152TA
D505-D508		RGP 10D	30-1268
D601-D602		IN4148 A-TYPE	30-1152TA
D603		RECTI 100VIA IN4002/1001	30-1002
D701-D706		RECTI 100VIA IN4002/1001	30-1002
ZD101-ZD102		ZENER HZ11B-2	30-1347-1
ZD201		ZENER HZ9C-1	30-1063-1
ZD501-ZD502		ZENER RD22EB3	30-1041
ZD503-ZD506		ZENER HZ3C1	30-1173-1
ZD701		ZENER HZ-16-1	30-1336
TRANSISTOR			
Q201		BC556B P -100MA -65V	30-2096
Q202-Q203		BC546 N 200MA 65V	30-2090
Q204-Q205		FET J111	30-2265
Q206		BC546 N 200MA 65V	30-2090
Q401-Q404		28C260G/H P 200MA 70V	30-2349
Q501-Q502		28C2259	30-2404
Q503-Q506		28B649AC P -1.5Z -160V	30-2259
Q507-Q510		28D669AC N 1.5A 160V	30-2260
Q511-Q512		28C2168 N 2A 200V	30-2391
Q513-Q514		28A958 P -2A -200V	30-2390
Q515-Q518		28C3519A N 15A 180V	30-2399-1
Q529-Q522		28A1386A P -15A -180V	30-2398-1
Q601-Q602		BF422	30-2237
Q603		BC556B P -100MA -65V	30-2096
Q701		BC640 P -1.5A -80V	30-2354
Q703		28D669AC N 1.5A 160V	30-2260
Q704		28B649AC P -1.5A -160V	30-2259
INTEGRATED CIRCUITS			
IC101-IC103		QUAD SW LC4066BH SANYD 14P	30-3244-2
IC201		FUNCTION SW LC7818 30P	30-3457
IC202		D-TYPE P/F CD4013B 14P	30-3008
IC301-IC302		DUAL OP M5219L 8P	30-3247
IC401		DUAL OP ML5220 8P	30-3272
IC601		PROTECTION TA7317P 9P	30-3187
MISCELLANEOUS			
VR301		VR RK 16B12MD	29-4302
VR302-VR304		VR 16: 50KX2	29-4300
VR305		VR 16: 50KM	29-4301
VR501		SEMI-FIX 8: 1KB FLAT	VR01-P08102B
L501-L502		COIL AIR 3.3UH	29-1147
		SW PUSH SPUB4C201-FL	31-1377
		XFMR TUNER	29-2156-4
		XFMR PW EI-114 120V UL CSA	29-2164-4
		FUSE 6.3X32MM UL CSA SLOW T8A	32-18001W
		COIL AIR 1.2: X6.9(12.6)DX30T	21-1147
		DIODE BRIDGE 200V1.5A W02	30-1040
		SW PUSH SPJ242NE01-FL	31-1275
		SW PUSH SUP12AE039-FL	31-1347
		LAMP AC18V 55MA 350MMX2	31-2049

REF NO.	AR'S PART NO.	DESCRIPTION	MFR'S PART NO.
MISCELLANEOUS			
		RELAY JC2ADC12V	35-3034
		RELAY 2P 18V 8A	35-3055
		CAPA 4700PF 400VAC KC	17-2014
		XFMR TUNER EI-41 220V DNSF	29-2156-5*A
		XFMR PW EI-114 220/240V DNSF	29-2164-5*A
		ANTI BIRGY FILTER KM-10XB 5305	29-3221
		SW SLIDE ESD-39	31-1378
		FUSE 5X20MM SEMKO SLOW 4A	32-14001B
		FUSE HOLDER PAN 20MM FH-033	32-2003
		SW SLIDE 10A/125V	31-1369
		FUSE 6.3X32MM UL CSA SLOW 4A	32-14001W
		FUSE 6.3X32MM UL CSA SLOW T8A	32-18001W

MECHANICAL PARTS LIST

ITEM	PART NO.	DESCRIPTION	Q'TY
1	21-2507	STICKER "PRESS"	1
2	11-8422	DOOR	1
3	13-4103	BADGE	1
4	12-3225	CONTROL KNOB	4
5	12-3222	PUSH BUTTON	10
6	11-8422-2	NAME PLATE	1
7	12-3217-1--8	MEMORY BUTTON FROM 1-8	1 EACH
8	11-8423	LED LENS GREEN	15
9	12-3218-1--5	FUNCTION BUTTON TAPE VCR TUNER CD/AUX PHONO	1 EACH
10	11-2444	BRACKET FOR DOOR	2
11	12-3220	AUTO/MANUAL BUTTON	1
12	12-3221-2	TUNING DOWN BUTTON	1
13	12-3221-1	TUNING UP BUTTON	1
14	11-8423-1	LED LENS PURPLE	9
15	12-5067	SPRING #5	21
16	12-3219	MUTE BUTTON	1
17	11-8424	WINDOW	1
18	13-4109	MYLAR PAPER	1
19	12-3216	VOLUME KNOB	1
20	11-2453	DRUM PLATE	4
21	11-8420	FRONT PANEL	1
22	29-4302	VOLUME VR & MOTOR	1
23	11-6238	BOTTOM CHASSIS	1
24	12-7027	CERAMIC TUBE 10m/m	12
25	12-7026	CERAMIC TUBE 7 m/m	16
26	12-7037	CERAMIC TUBE 11 m/m	2
27	30-1333	LED GREEN (HL)	15
28	28-1088	BUSHING CONNECTOR	21
29	11-9177	REFLEX PLATE	1
30	11-2434	HEADPHONE BRACKET	1
31	28-1087	BUSHING STOP	10
32	12-5068	PUSH SPRING	10
33	31-2049	LAMP	1
34	28-1016	LAMP HOLDER	1
35	31-1347	POWER SWITCH	1
36	11-2439	BRACKET FOR POWER SWITCH	1
37	11-8406	POWER LENS (RING)	1
38	11-6236	LEFT CHASSIS	1
39	12-3201	POWER BUTTON	1
40	28-1058	RUBBER FOOT	4
41	29-2156-*	TUNER TRANSFORMER	1
42	30-1337	BRIDGE DIODE	1
43	28-2090	RETAINER 2 m/m	6
44	50-1059-1	CABINET	1
45	29-2164-*	TRANSFORMER	1
46	35-3034	POWER RELAY	1
47	11-6235	FRONT CHASSIS	1
48	11-2432	BRACKET A	2
49	11-3122	THERMAL HOLDER	2
50	28-2163	RETAINER 2 m/m	2
51	31-3026	DIGITAL DISPLAY TUBE	1
52	11-2433	BRACKET B	2
53	90-1435	TUNER PCB	1
54	90-1466	TONE CONTROL PCB	1/2
55	90-1466	TONE CONTROL PCB	1/2
56	31-1377	AM/FM MEMORY SWITCH	1
57	11-2402-1	BRACKET	2
58	11-9174	SHIELD COVER	1
59	11-9175	SHIELD CASE	1
60	11-3141	LED HOLDER	1
61	90-1474	FUNCTION DISPLAY PCB	1
62	11-6237	RIGHT CHASSIS	1
63	11-5089	HEAT SINK	2
64	12-2227	6P RCA JACK	1
65	12-2225	4P RCA JACK	1
66	11-9120*A	FRONT END SHIELD	1

ITEM	PART NO.	DESCRIPTION	Q'TY
67	11-9157	FRONT END COVER	1
68	90-1465	PHONO PCB	1
69	13-4075	MYLAR PLATE	1
70	28-2058*A	SPONGE	4
71	11-2451	BRACKET FOR PHONO	1
72	12-230	DIN JACK	1
73	12-2224	SPK TERMINAL	1
74	31-1388	VOLTAGE SELECTOR	1
75	12-2193	AC OUTLET	1
76	11-8421-1--4	BACK PANEL	1 EACH
77	12-1029(1032)	75Ω CONNECTOR & NUT	1 EACH
78		WASHER	1
79	12-2223	ANT SOCKET	1
80	28-2113	ANT HOLDER A	1
81	15-2037*C	GROUND SCREW	1
82	12-3T02-1	PUSH KNOB BLACK	1
83	11-3026	LUG	1
84	11-8422-1	NAME PLATE FOR BASS TREBLE	1
85	11-9178	SHIELD FOR SPK	1
S1	S2E2.6+I06SL-2	FLATE TAPPING SCREW FT2.6x6	2
S2	S2B03+I06SL-2	TAPPING SCREW T3x6	40
S3	S2B03+I08SL-2	TAPPING SCREW T3x8	31
S4	15-2063	STANDER SCREW	4
S5	S1B03+I06SL-2	MACHINE SCREW M3x6	14
S6	15-2062	SPECIAL SCREW M4x6	4
S7	S1B03+I08SL-2	MACHINE SCREW M3x8	1
S8	S1B03+I10SL-2	MACHINE SCREW M3x10	8
S9	15-2075	SPECIAL SCREW	4
S10	S1B02+I04SL-2	MACHINE SCREW M2.6x4	3
S11	15-2048*A	RIVET #3x5.5	2
S12	S1E03+I06SL-2	FLATE SCREW FT3x6	10
W1	A3.5A09SN01	GEAR WASHER #3.5x#9	1
W2	A3.5A08FO.5	FIBER WASHER #3.5x#8	6
N1		VR NUT M7.0	5
N2	N3.5B06I2.8SN	NUT M3.5x2.8T	1
N3	N03B5.5I02BN	NUT M3x2T	3
N4	N04B07I3.2SZ	NUT M4x3.2T	4

ASSEMBLY DIAGRAM

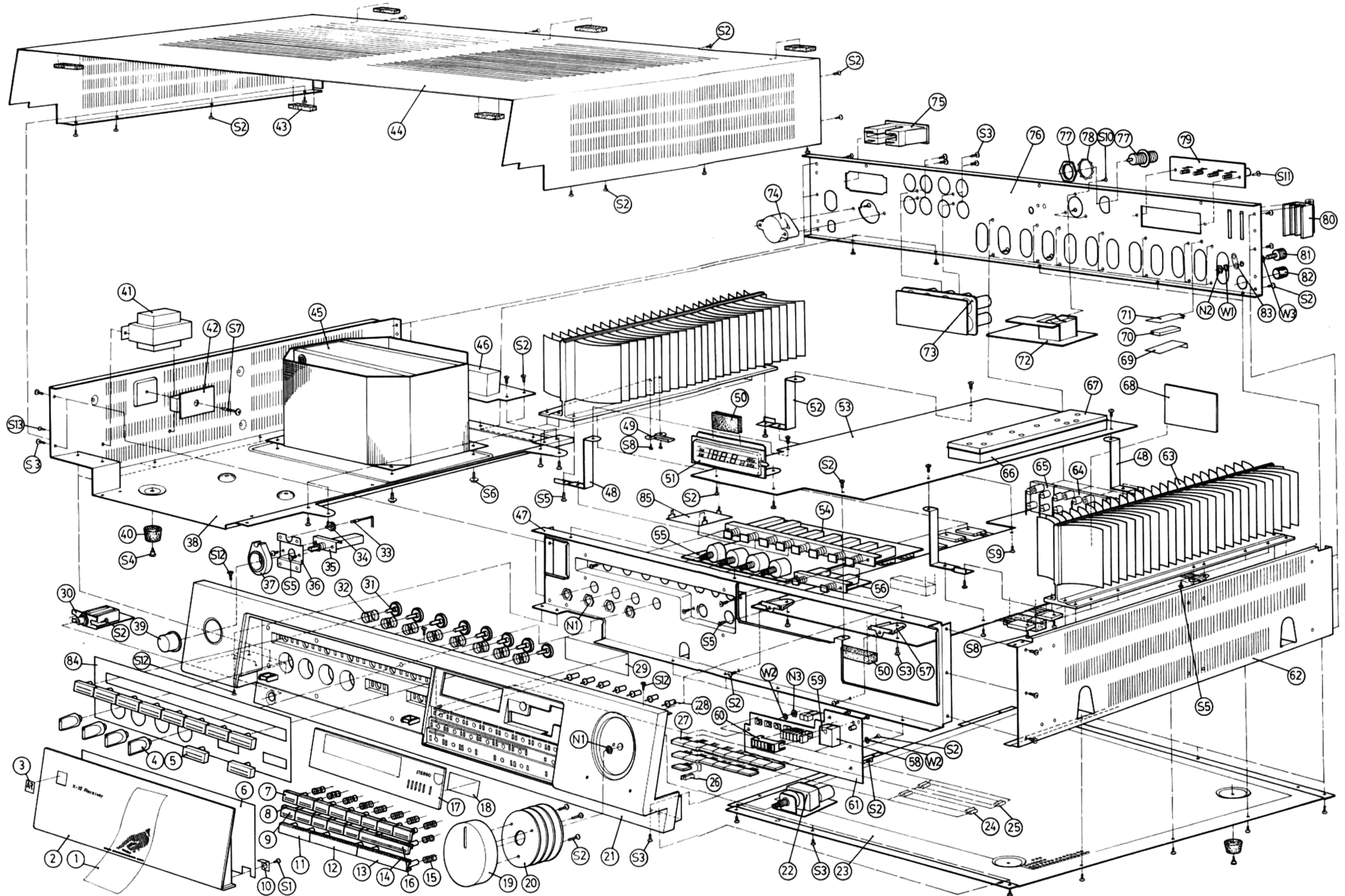

EXPLODED VIEW OF RC-02A

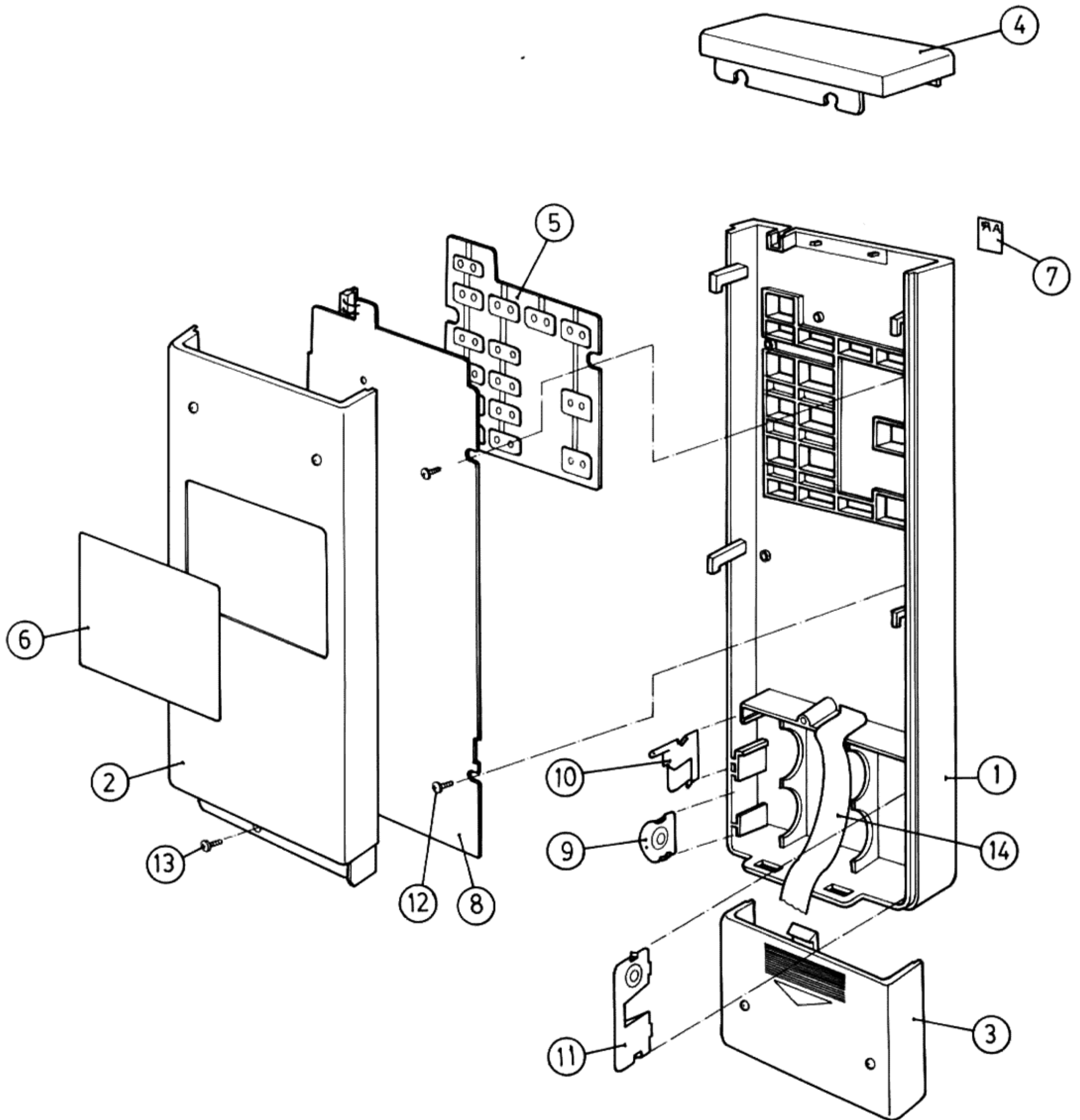

ITEM	PART NO.	DESCRIPTION	Q'TY
1	11-1182	FRONT COVER	1
2	11-1177-1	REAR COVER	1
3	11-1176-1	BATTERY COVER	1
4	11-8354-1	ACRY FILTER	1
5	12-3200	RUBBER KNOB	1
6	13-4102	BRAND SHEET	1
7	13-4103	BADGE	1
8	19-1434*A	P.C.B.	1
9	12-1153	BATTERY CLIP	1
10	11-5T27	BATTERY CLIP	1
11	11-5T28	BATTERY CLIP	1
12	S2D02+105SZ-2	TAPPING SCREW	5
13	S2D03+110SL-2	TAPPING SCREW	1
14	11-9156	BATTERY RELEASE	1

PCB DRAWING OF REMOTE CONTROL CIRCUIT (TOP VIEW)

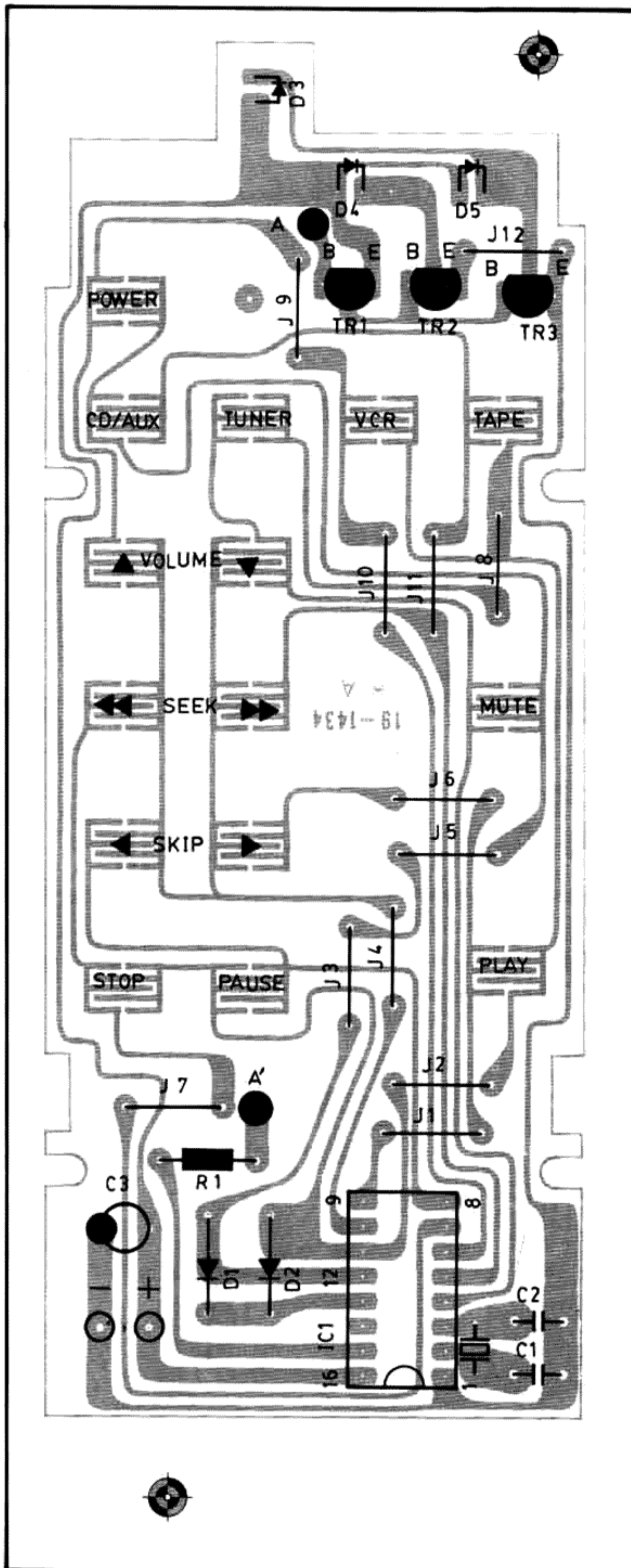
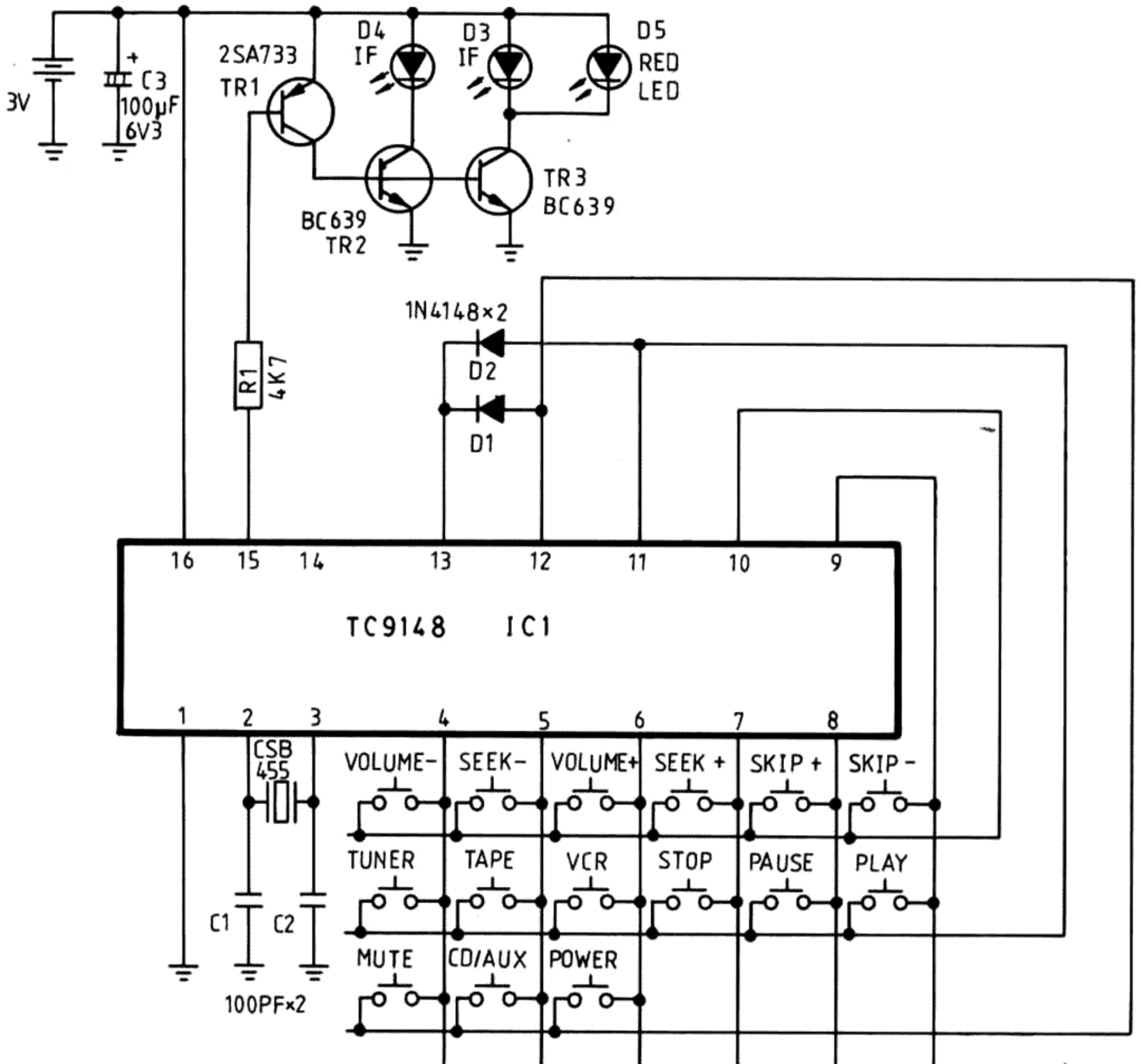

DIAGRAM OF REMOTE CONTROL CIRCUIT



ELECTRICAL PARTS LIST FOR RC-02A

REF. NO.	AR'S PART NO.	DESCRIPTION	MFR'S PART NO.
R1		4.7K OHM 1/4W	16-1/4CS472J
C1-C2		CERAMIC 100P 50V +-10%	17-5DF101K
C3		ELECTROLYTIC 100U 10V +-20%	17-1M107M
D1-D2		IN4148	30-1152
D3		LED RD LTL-3217A	30-1127
D4-D5		DIODE INFRAED EMITTING 520B	30-1320
TR1		TR 2SA733P	30-2171
TR2-TR3		TR BC639	30-2353
IC1		IC TC9148P	30-3434
CR1		CR CSB455E	29-3174
		WIRE PVC #24 1007 BK	W2-0F
		WIRE PVC #24 1007 BN	W2-1F
		WIRE PVC #24 1007 RD	W2-2F