

ADCOM[®]

GFA-1, 1a
AMPLIFIER

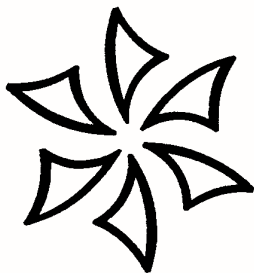

SERVICE MANUAL

ADCOM

11 Elkins Road
E. Brunswick, NJ 08816
(908) 390-1130

GFA-1 Service Manual

CONTENTS

Introduction

Section 1.....Circuit and Theory
Section 2.....Service information
Section 3.....Operational Specifications
Section 4.....Schematic Diagrams
Section 5.....Board views
Section 6.....Parts listing

INTRODUCTION

This manual provides the technical and service information required to perform all forms of maintenance to the GFA-1 and GFA-1a Power Amplifiers.

Section 1 covers the theory of operation and testing of the amplifier

Sections 2, 3, 4, 5 and 6 provide the information essential to the service

SECTION 1
CIRCUIT and THEORY

GENERAL DESCRIPTION

The ADCOM GFA-1 (and GFA-1a) Balanced Bridge Power Amplifiers are 2 pairs of true complementary-symmetric power amplifiers (4 amplifiers) mounted on a common chassis. Two of the four power amplifiers are driven out of phase as a pair of "bridging" amplifiers. This technique creates a balanced output from an un-balanced input. The amplifier employs input bandwidth limitation to control RF and T.I.M. related high-frequency aberrations. The amplifier features a unique main-frame construction with a high efficiency forced-air cooling system. The 1a version incorporates an advanced protection technique offering "full coverage" electronic operating protection.

BRIDGING FOR POWER

Bridging two power amplifiers is an engineering technique which permits the combining of the safe operating aspects of a smaller amplifier with the power and price needs of the high fidelity marketplace. Our experiment

and looking at the voltages that appear between the two outputs, we get the sum of the two outputs. This output is twice the voltage of either separate output. As the mathematics for power are a squared function, doubling the voltage means four times the power. Thus, the bridging configuration yields low-cost high power safely.

CIRCUIT DESCRIPTION

POWER AMPLIFIERS

Referring to the GFA-1a schematic (section 3) the amplifier operates as follows:

The incoming signal is DC decoupled by C1 with R1 and C3 providing frequency limiting and R.F. protection. This signal is then applied to the bases of Q1 and Q4 as one of the bridging signals and Q2 and Q3 for the other. Q1 and Q4 drive transistors Q5 and Q6 completing the voltage drive portion of the positive amplifier. These signals are then fed to the output stage made up of Q10, Q11, Q12, and Q13. This output section is biased and thermally tracked by the network made up of CR30 and Q16. Feedback from this positive amplifier is returned to Q1 and Q4 via resistor R24. This same signal via R25 is fed to Q2 and Q3 which form the input

section of the negative signal amplifier. Q6 and Q7 comprise the remainder of the voltage gain stage for the negative side. This negative signal then drives the output section made up of Q14, Q15, Q16 and Q17 which is biased and thermally tracked by Q18 and the diode CR31. The two power amplifiers making up the bridging amplifier channel share a common power supply and common floating voltage regulation provided by diode CR3.

POWER SUPPLY

All power is provided by a common power transformer utilizing separate power diode rectification and separate filtering capacitors (C26 through C29). Two speed fan operation is provided by switch S2 and limiting resistor R89.

VARIATIONS BETWEEN THE GFA-1 and the GFA-1a

In our description of the operation of the GFA-1a and our reference to the schematic we made no mention of the protection circuits employed.

These protection circuits are the major differences between the GFA-1 and

the GFA-1a. Please note the short protection schematic in section 3. This is the GFA-1a protection schematic. The protection integrated circuit U1 has been added and the old protection system of the GFA-1 obsolete. Transistors Q19 and Q20 (along with their adjacent channel equivalents of Q22 and Q23) constantly monitor the positive going output current to establish dynamic current limiting.

The GFA-1a also utilizes an improved thermal tracking network by attaching diodes CR30 and CR31 to the heat sink and has replaced the power supply rectification diodes (originally on the PCB) with a set of full-wave bridge rectifiers mounted on the heat sink for superior cooling. In addition the GFA-1a incorporates a set of peak power monitors in the form of transistors Q25 and Q26 driving LED's CR28 and CR29.

SECTION 2
SERVICE INFORMATION

Test Set-Up

A-INTRODUCTION

of bridged amplifiers. The use of common grounds in the output system will cause considerable problem. Testing will require a FIRST-CLASS test set-up consisting of good equipment and good connections. SHOULD EITHER OF THESE REQUIREMENTS FALL SHORT, NO SERVICE SHOULD BE ATTEMPTED .

Throughout the course of this manual we strive to present the shortest and most practical service pathway. The technician is advised to read the manual before attempting service to assure the best use of his time.

B-EQUIPMENT

Servicing the GFA-1 series of power amplifiers will require the following types of equipment. We have identified appropriate manufacturers and models as guidelines.

3. Audio generator- An unbalanced output audio generator with less than 0.002% T.H.D. over the frequency range of 20 Hz to 20 kHz at a 3 volt output level. We suggest the use of the generator portion of the Sound Technology 1701A.

4. Oscilloscope- Capable of balanced input and a vertical sensitivity of 30 mv. The unit should have triggered sweep and a 10 MegaHertz bandwidth.

5. Line Controller- A "Variac" type of main power line controller. Adjustable from 0 to 130 volts, this unit should have a 25 amp capability. As all IHF tests require a main voltage of 120 volts throughout the test, only a high quality controller with good high current line regulation should be used (Staco, General Electric, General Radio, Superior Electric, etc..).

6. Load- a fully isolated 8 ohm non-inductive load with less than 500 pfd intrinsic capacity. The load should be capable of dissipating over 400 watts and be connected to the power amplifier with at least #14 wire.

screwdriver (we suggest an electric drive), a soldering iron of at least 35 wats, a solder sucker or equal, pliers, and diagonal cutters.

Attach the load to the output of the power amplifier. Make sure that the load has no connection with any other part of the test set-up. This means that the load has no "hot" and "ground" only a "+" and a "-". When operating in the "both channels driven" mode, the load should be connected to both channels.

input of the distortion measuring unit should be attached to the amplifier's output in the same manner.

UNBALANCED TEST EQUIPMENT

If there is no alternative to the use of unbalanced test equipment the technician is reminded that a 200 watt bridging amplifier is really a pair of 50 watt power amplifiers, one of which is operating out-of-phase with the other. Measuring from chassis ground to either the "+" or "-" output you will get roughly 60 watts into 8 ohms. Remember that the "-" output is NOT ground but an out-of-phase signal. The distortion measurement will be better than specified and the slew rate will be about \times . All

DISASSEMBLY

Once the unit has been assessed as defective further service will require opening the unit. Place the GFA-1a on the bench in front of you with the POWER SWITCH end towards you.

Using a #6 phillips screwdriver follow these steps:

- a- Remove the 8 end screws.
- b- Remove the 10 screws around the edge of this end cap.
- c- Remove the 10 screws around the other end cap (this is the end with the speaker outputs).
- d- Slide off the end cap facing you (the one with the power switch).
- e- Slide the top cover piece out towards you and lift it away.

At this point the printed circuit board is fully accessible for voltage measurements.

POWER TRANSISTOR REPLACEMENT

Once the unit has been opened and the fault mode assessed as including the failure of an output transistor, the following additional disassembly procedure must be followed:

- f- Remove the 6 side screws on the bottom cover (three on each side).
- g- Slide the bottom cover off.
- h- Carefully roll the unit over onto the printed circuit board.
- i- Remove the 4 standard screws securing the black power transformer.

Set the transformer to the right of the unit and remove the steel plate securing it.

j- Using a long phillips screwdriver, remove the four screws securing the power transistor covers and slide these covers out of the heat sink.

k- Remove and replace the appropriate power transistors.

After completing repairs reassemble the unit in reverse order. Be especially careful not to pinch wires or drop debris into the unit while reassembling.

SECTION 3

Operational Specifications

(As per IHF A-202, 1978)

- 1- CONTINUOUS AVERAGE POWER OUTPUT is the minimum power available over the frequency range of 20 Hertz to 20 kiloHertz at less than the rated distortion (IHF 3.1) this output level is 200 watts per channel into 8 ohms and 350 watts per channel at 4 ohms.
- 2- DYNAMIC HEADROOM is the ratio between the power at 3% THD and the continuous power noted in step 1 at 1 kiloHertz (IHF 3.2.3) and is 1.3 dB.
- 3- FREQUENCY RESPONSE is the change in output compared to the input with a frequency of 1 kiloHertz as the "0" reference point (IHF 3.13.1) and is +, -0.25 dB from 20 Hertz to 20 kiloHertz at 200 watts, both channels driven, onto 8 ohm loads.
- 4- SENSITIVITY is the input voltage required to produce an output of 1 watt into 8 ohms (2.83 volts RMS) (IHF 3.7) and is 72 millVolts RMS for a gain of 31.5 db.
- 5- "A" WEIGHTED SIGNAL TO NOISE RATIO is the ratio between a 1 watt into 8 ohm output signal level and the output when the input has no signal and is terminated with a 1 kilohm resistor. The noise is filtered through a standard "A" type network (IHF 3.12.2) and is 90 db.
- 6- LOW FREQUENCY DAMPING FACTOR is the ratio between an 8 ohm load and the 50 Hertz output impedance (IHF 3.11.2) and is 60.
- 7- CROSSTALK is the ratio of the worst cross channel leakage over a range of 100 Hertz to 10 kiloHertz (IHF 3.14.1) and is 50 dB at 10 kiloHertz.

8- SMPTE INTERMODULATION DISTORTION is the distortion resulting from the amplification of a signal consisting of a 4 to 1 mixture of 60 Hertz and 7 kiloHertz (IHF 1.18 and 3.15.4) and is less than 0.1% at an output level of 200 watts into 8 ohms.

SECTION 4

SCHEMATIC DIAGRAM WITH VOLTAGES

ADCOM GFA-1a

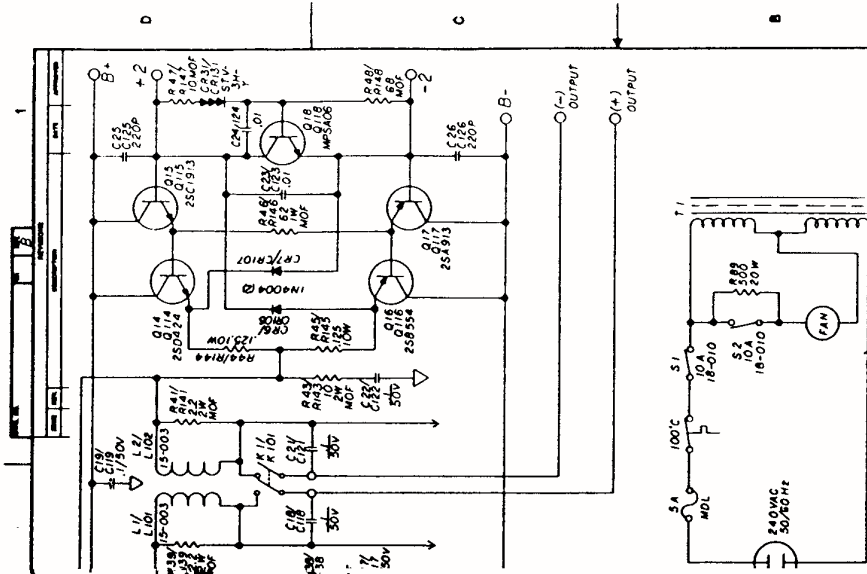

EXPORT

MDC-METAL OXIDE FILM RESISTOR DESIGNATED
 FLAME PROOF RESISTOR
 REFERENCE DESIGNATIONS R1/R101, C1/C101, ETC. = CH A/CH B.
 RESISTORS INDICATED IN OHMS, 1/4 W, 5%.
 CAPACITORS INDICATED IN MICROFARADS.
 UNLESS OTHERWISE SPECIFIED.

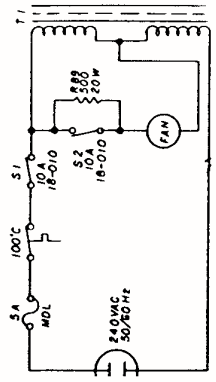

PROJECT NO.		DATE	DESIGNER	DR.	CHKD BY
PART NO.		REV.	R. L. IN		6-28-79
SYM. NO.		A-2007			
CONTRACT NO.					
WORK ORDER NO.					
JOB NO.					
PT. NO. OF WORK SHEETS		1			
OF TOTAL WORK SHEETS		1			
ADCOM			SCHEMATIC		
DRAWN BY		CHECKED BY		DATE	
REVISIONS					
1		2		3	
4		5		6	
7		8		9	
10		11		12	
13		14		15	
16		17		18	
19		20		21	
22		23		24	
25		26		27	
28		29		30	
31		32		33	
34		35		36	
37		38		39	
40		41		42	
43		44		45	
46		47		48	
49		50		51	
52		53		54	
55		56		57	
58		59		60	
61		62		63	
64		65		66	
67		68		69	
70		71		72	
73		74		75	
76		77		78	
79		80		81	
82		83		84	
85		86		87	
88		89		90	
91		92		93	
94		95		96	
97		98		99	
100		101		102	

ADCOM	
GFA-1A	SCHEMATIC
DATE: 9-17-52	DRAWN BY: J. B. J.
DESIGNED BY: [Blank]	CHECKED BY: [Blank]
APPROVED BY: [Blank]	PART NO. [Blank]
REVISIONS	
NO. 1	DATE

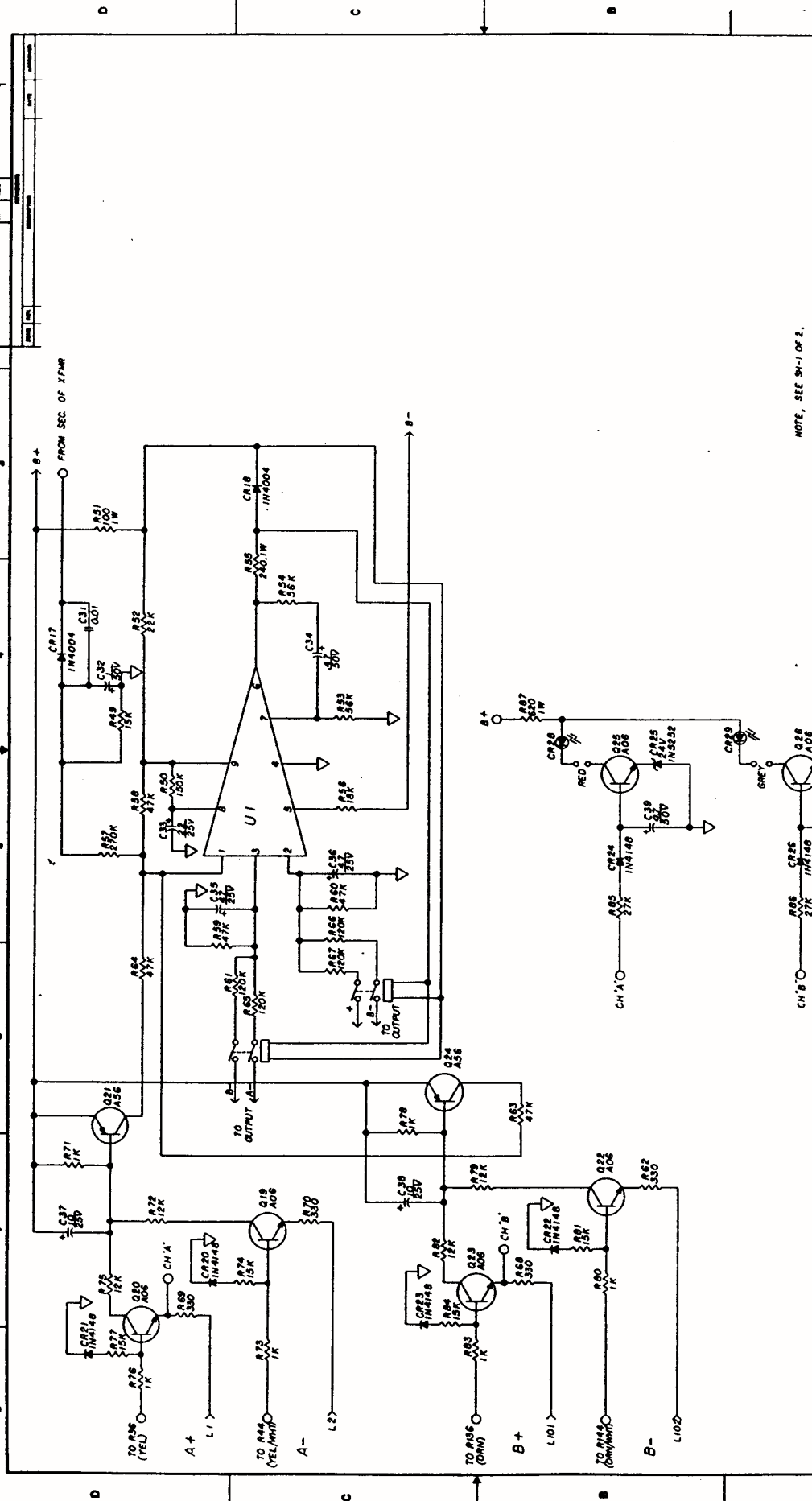

NOTE: SEE SH-1 OF 2.

REV. NO.	DATE	REVISIONS	BY

REV. NO.	DATE	REVISIONS	BY

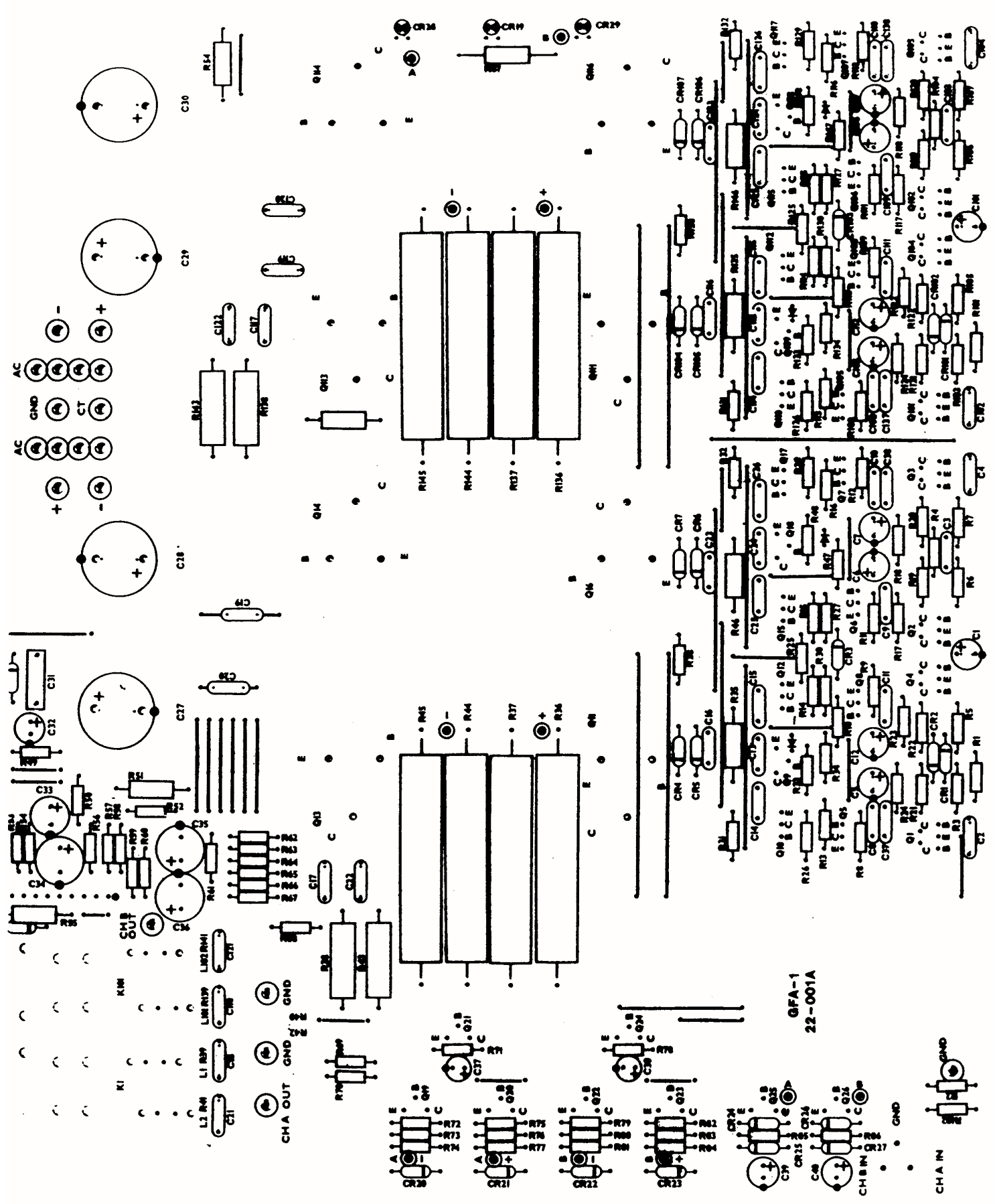

GFA-1
22-001A

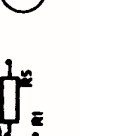
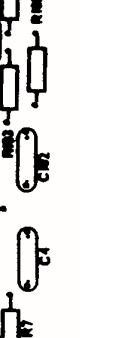
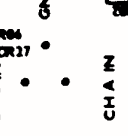
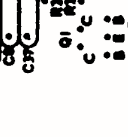
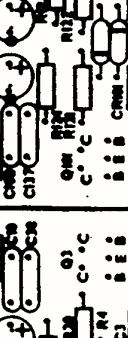
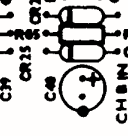
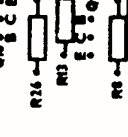
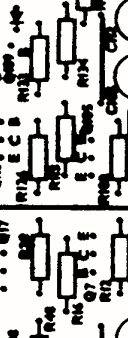
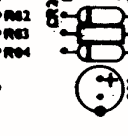
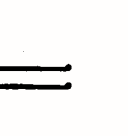
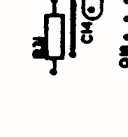
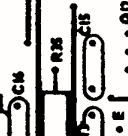
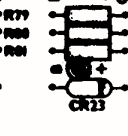
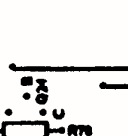
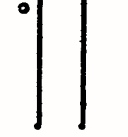
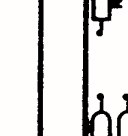
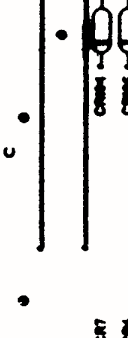
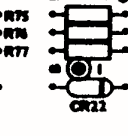
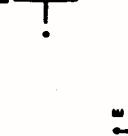
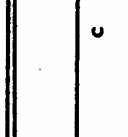
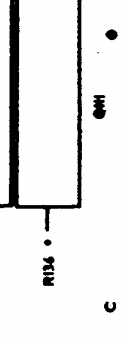
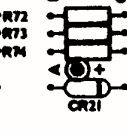
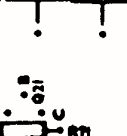
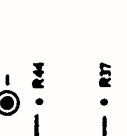
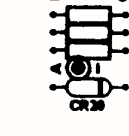
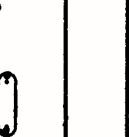
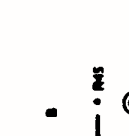
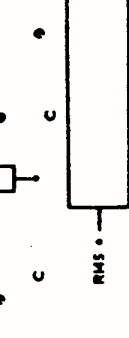
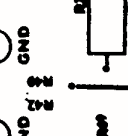
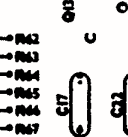
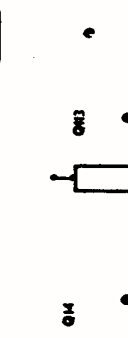
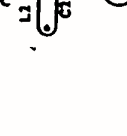
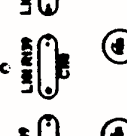
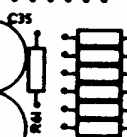
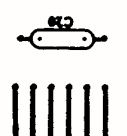
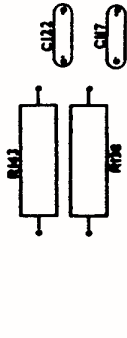
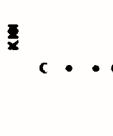
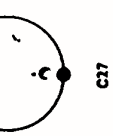
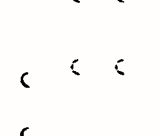
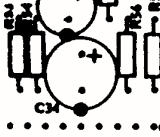
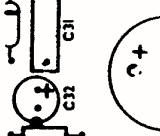
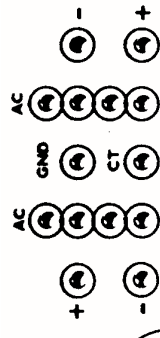

CM



CM

CM

CM

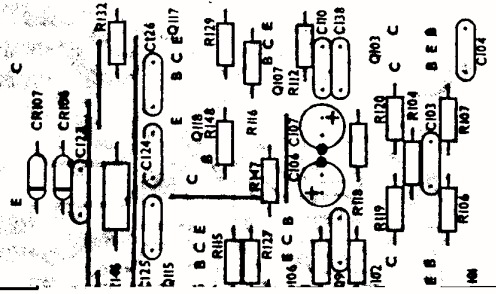

MODEL GFA-1a

DATE 09-11-80

PREVIOUS

PAGE 1 OF 3

ITEM 22-001-A

ASSEM. DESC. PC ASSEMBLY

ART NO	QTY	DESCRIPTION	REF. DESIG.
01-003-2	6	R: 2KOHM 2% 1/2W CF	
01-002-2	16	R: 1KOHM 2% 1/2W CF	
01-010-2	8	R: 39KOHM 2% 1/2W CF	
01-005-2	8	R: 10KOHM 2% 1/2W CF	
01-009-2M	8	R: 1.2KOHM 2% 1/2W CF-M	
01-008	12	R: 68 OHM 5% 1/2W MOF	
01-004-2	4	R: 3.3KOHM 2% 1/2W CF	
01-013	8	R: 10 OHM 5% 1/2W MOF	
01-006	2	R: 330 KOHM 5% 1/2W CF	
01-040	2	R: 27 KOHM 5% 1/2W MOF	
01-016	5	R: 15 KOHM 5% 1/2W CF	
01-011	6	R: 1 KOHM 5% 1/2W MOF	
01-017	4	R: 12 KOHM 5% 1/2W CF	
01-018	4	R: 330 OHM 5% 1/2W MOF	
01-019	4	R: 120 KOHM 5% 1/2W CF	
01-020	5	R: 47 KOHM 5% 1/2W CF	
01-021	1	R: 270 KOHM 5% 1/2W CF	
01-022	1	R: 18 KOHM 5% 1/2W CF	
01-023	1	R: 150 KOHM 5% 1/2W CF	
01-024	1	R: 22 KOHM 5% 1/2W CF	
01-025	2	R: 56 KOHM 5% 1/2W CF	
03-001	1	R: 10 OHM 5% 1/2W MOF	
03-002	1	R: 240 OHM 5% 1/2W MOF	
04-011	1	R: 620 OHM 5% 1W MOF	
04-002	4	R: 62 OHM 5% 1W MOF	
04-004	4	R: 10 OHM 5% 2W MOF	
04-007	1	R: 100 OHM 5% 1W MOF	
04-003	1	R: 3.9 KOHM 5% 1W MOF	
04-005	4	R: 2.2 OHM 5% 2W MOF	
04-006	8	R: 125 OHM 10% 10W MOF	

MODEL GFA-1a

DATE 09-11-80

PREVIOUS

PAGE 2 OF 3

SM 22-001-A

ASSEM. DESC. PC ASSEMBLY

PART NO	QTY	DESCRIPTION	REF. DESIG.
07-006	12	C: .1 MF + 80 100v GPC	
07-004	4	C: 10PF 10% GPC	
07-003	8	C: 47PF 10% GPC	
07-001	10	C: 220PF 10% GPC	
07-002	9	C: .01MF +80 100v GPC	
08-006	4	C: MY .1MF 100V RA DIP	
09-002	6	C: EL 100MF 10v RA	
09-001	4	C: EL 10 MF 50V RA	
09-004	2	C: EL 4.7 MF 50V RA	
09-006	2	C: EL 47 MF 16V RA	
09-007	1	C: EL .47 MF 50V RA	
09-008	1	C: EL 1 MF 50V RA	
09-009	1	C: EL 22 MF 16V RA	
09-010	2	C: EL 10 MF 25V RA	
09-005	4	C: EL 8200 MF 63V RA	
11-002	10	DL: IN 4004	
11-005	2	DL: IN 5262 B 51V 5% ZEN	
11-003	10	DL: IN 4148	
11-018	2	DL: IN 5252 B 24V 5% ZEN	
11-007	6	TR: MPS A06 NPN	
11-006	2	TR: MPS A56 PNP	
11-009	4	TR: 2SA798	
11-010	4	TR: 2SC1583	
11-013	4	TR: 2SA914	
11-012	4	TR: 2SC1953	
11-019	1	IC: TA7317-P	
11-022	4	TR: MPS A06 SEL (Beta 70-120)	
12-003	2	RELAY: FRL264 D048/02CK	

MODEL GFA-1a

DATE 09-11-80

PREVIOUS

PAGE 3 OF 3

SM 22-001-A

ASSEM. DESC. PC ASSEMBLY

PART NO	QTY	DESCRIPTION	REF. DESIG.
15-003	4	CHOKE: OUTPUT	
17-006-A	1	PC BD: MAIN (GFA-1a)	
18-005	8	SOCKET: TR EMUDEN M 1629	
18-006	1	JACK: EMUDEN 5526	
18-004	1	LUG: #6 SOLDER	
18-018	8	LUG: 1/4" PUSH, CRIMP # 16 GA	
21-026	5	JUMPER: #22 GA SLD BLK PVC .4"	
21-027	1	JUMPER: #22 GA SLD BLK PVC .2"	
21-010	15	JUMPER: #22 GA SLD PVC BLK .5"	
21-012	7	JUMPER: #22 GA SLD PVC BLK .75"	
21-015	1	JUMPER: #22 GA SLD PVC BLK 1"	
21-013	8	JUMPER: #22 GA SLD PVC BLK 1.5"	
21-011	5	JUMPER: #22 GA SLD PVC BLK 2"	
21-008-06	6	WIRE: #16 GA STRD RED	
21-007-06	2	WIRE: #16 GA STRD GRY	
21-005-03	1	WIRE: #16 GA STRD BLK	
21-005-11	1	WIRE: #16 GA STRD BLK	
21-016-12	1	WIRE: #22 GA STRD RED	
21-017-12	1	WIRE: #22 GA STRD GRY	
21-018-12	1	WIRE: #22 GA STRD ORG	

MODEL GFA-1a

DATE 09-22-80

PREVIOUS

PAGE 1 OF 3

BM 50-003

ASSEM. DESC. FINAL ASSEMBLY

PART NO	QTY	DESCRIPTION	REF. DESIG.
04-010	1	R: 500 ohm 10% 20W WW	
11-016	2	DI: BRIDGE 25A	
11-014	4	TR: 2SB554 PNP (R)	
11-015	4	TR: 2SD424 NPN (R)	
11-020	4	TR: 2SA1111 PNP	
11-021	4	TR: 2SC2591 NPN	
11-017	4	DI: STV - 3H - Y	

12-001	1	FUSE: 10A 250V MDA	
12-002	1	THERMOSTAT: 100 DEG	
12-005	2	SWITCH: POWER (OSLO)	

MODEL GFA-1a

DATE 09-12-80

PREVIOUS

PAGE 2 OF 3

SM 50-003

ASSEM. DESC. FINAL ASSEMBLY

PART NO	QTY	DESCRIPTION	REF. DESIG.
18-001	1	FUSE HOLDER: BUSS HKP	
18-002	1	RELIEF: HEYCO SR-5KN-4	
18-008	8	INS: TO-220	
18-007	1	TERM: SMK XQ 2754-01	
18-003	1	CONN: 10-18 GA WAT	
18-027	1	TERM: HHS-863	
18-020	8	INS: TO-3	
18-015	4	BUSHING: HEYCO B-187-125	
18-021	2	BUSHING: HEYCO SB-375-4	
19-007	4	FEET: 3M SJ-5023 BLK	
19-006	41	SCREW: 6-32 x 1/2 REV PH BLK	
19-005	2	SCREW: #4 x 5/16 PH	
19-003	6	NUT: PRESS 10-32-2	
19-011	8	NUT: PRESS 4-40-2	
19-004	2	SCREW: 10-32 x 1/2 PHSS BLK	
19-001	4	SCREW: 10-32 x 3/8 PH NP	
19-002	4	WASHER: #10 INT STAR ZP	
19-036	4	SCREW: 6-32 x 5/16 PH REV BLK	
19-025	4	STANDOFF: 1/2 x 7/16 x 6-32 BR NP	
19-032	2	SCREW: 10-32 x 3/4 PH NP	
21-001	1	FAN: HOWARD	
21-002	9	TIE RAP: 3/4 DIA TY-23-M	
21-004	1	LINE CORD: C - 1248 MESS	

MODEL GFA-1a

DATE 09-12-80

PREVIOUS

PAGE 3 OF 3

BM 50-003

ASSEM. DESC. FINAL ASSEMBLY