

MODELS 4R11, 4R12,
Ch. 4R1

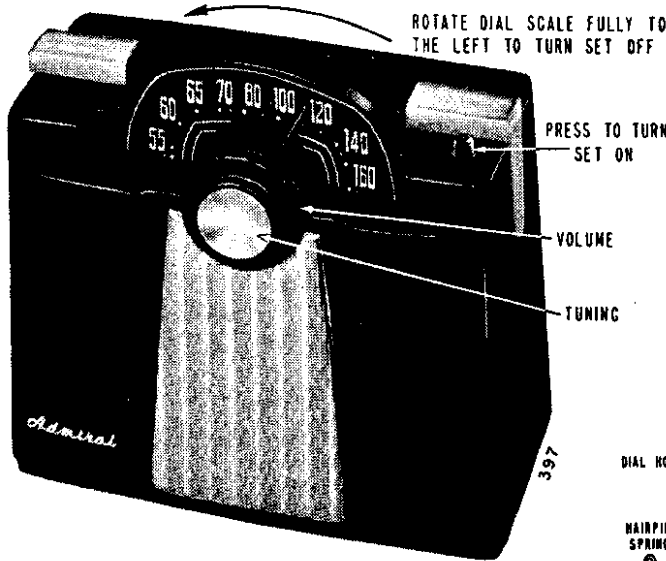

REMOVING AND INSTALLING CHASSIS

To remove the chassis from the cabinet, remove the tuning knobs, cabinet bottom (base) and metal speaker grille. The speaker grille is removed by pulling it down away from the cabinet.

Release the chassis by removing the two mounting screws located in the top inside of the cabinet just below the handle brackets. Install the chassis in cabinet in the same manner, being sure that the 1/16" diameter fibre washer (sleeve retainer) is placed over the volume tuning sleeve just before sliding the chassis into the cabinet.

Also, before tightening the two chassis mounting screws adjust the chassis for even spacing between all sides of the dial and the cut-out in the cabinet, otherwise binding may result. In some early sets, the bottom of the dial can be leveled with the top surface of the cabinet (when dial is fully concealed) by adjusting the bracket adjustment screw called out in the front view illustration of the "Hide-A-Way" dial.

WEAK RECEPTION DUE TO SLIPPING VOLUME DRIVE CORD.

Weak reception can be caused by the slipping of the volume drive cord. If the set is still weak after the batteries and tubes have been checked, it is a good idea to check the volume drive for slipping. To make this check, first remove the "A" battery from the cabinet and connect outside of the set. Turn the set on and fully rotate the volume knob to the right (clockwise). Then reach into the cabinet and rotate the volume pulley on the volume control as far to the right (clockwise) as it will go. If the volume increases, it will be necessary to remove the chassis from the cabinet and check the stringing of the volume drive cord. See paragraph "Stringing Volume Control Drive".

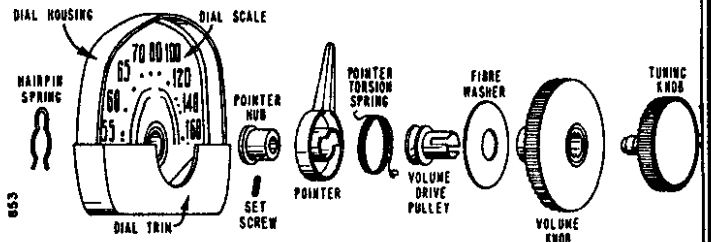

Dial and Tuning Knob Assembly, Exploded View

STRINGING VOLUME CONTROL DRIVE

Illustrations below show volume cord stringing used in early and in late production sets.

Before restringing the volume cord, rotate volume control fully clockwise and, using a #6 Allen wrench, tighten the set screw on the volume control pulley, first being sure the cut-out slots on the pulley are in the position shown in the illustration. Loop the cord in the cut-out slots, winding 1 1/2 turns around the volume control pulley, and then winding 2 turns around the volume tuning sleeve. In late sets loop the cord around the fibre pulley to the left of the set. To prevent slipping, be sure that the volume control turns freely and that the dial cord tension spring has sufficient tension.

"HIDE-A-WAY" DIAL

Illustrations below show front, rear and exploded views of dial mechanism. Follow the sequence shown in exploded view for disassembly or reassembly of the knobs, pointer or dial.

The "Hide-A-Way" dial mechanism is operated by the push button which works the trigger release bracket. The trigger bracket releases the dial assembly.

Thrust of the lever arm roller against the cam on back of the dial causes the dial to pop-up while a protruding edge on the lever arm simultaneously trips (turns on) the on-off switch.

Lever arm thrust is adjustable by attaching the far end of the lever arm spring to any of the holes spaced at different distances from the lever arm.

Rotating the dial fully to the left locks the dial into the cabinet and also trips (shuts-off) the on-off switch.

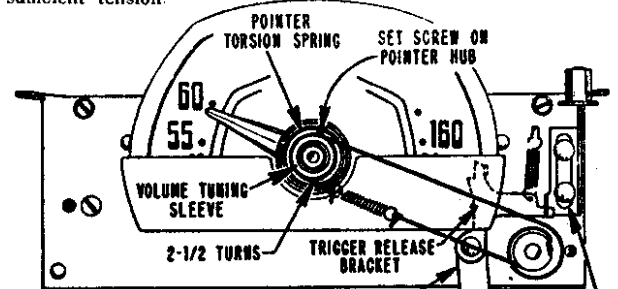

"Hide-A-Way" Dial, Front View (early set)

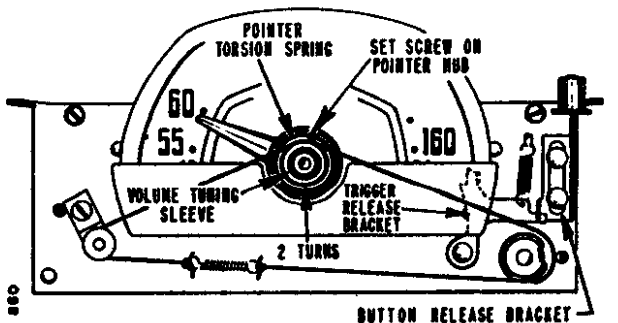

"Hide-A-Way" Dial, Front View (late set)

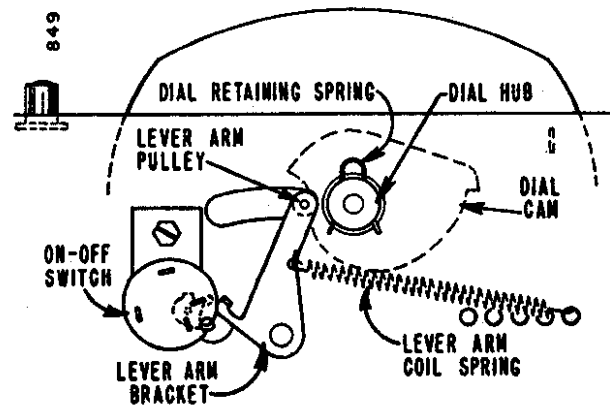

"Hide-A-Way" Dial, Rear View

MODELS 4R11,
4R12, Ch. 4R1

DIAL POINTER

The illustration shows an exploded view of the dial assembly and the sequence in which the pointer hub and torsion spring are to be assembled. When assembling the pointer torsion spring to the pointer, insert the rectangular end into the base of the pointer; compress the spring from about one-half to one turn in a clock-wise direction. Insert the rounded or looped end of the spring over the top end of the pointer set screw. Allow about 1/64" clearance between the inner turn of the pointer spring and pointer hub, or the pointer may bind or stick.

To adjust pointer, fully close the gang condenser. Set the end of the pointer over the two dots below 55 on the dial and tighten the pointer screw with a #4 Allen wrench. Important: Allow approximately 1/32" clearance between the hub on the pointer and the dial scale.

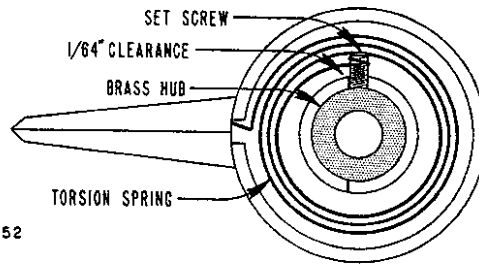

852

Dial Pointer and Hub Assembly

ALIGNMENT PROCEDURE

- Use battery power for alignment if fresh batteries are available.
- When using AC power, an isolation transformer should be used if available. If not using an isolating transformer, connect a .1 mfd. condenser in series with the signal generator low side to B minus (Pin 7 of 1U5 tube).
- Batteries should be held in chassis during alignment.
- Set volume control full on.
- Connect output meter across speaker voice coil.
- Use lowest setting of signal generator capable of producing adequate output meter indication and then proceed as outlined below.
- Use a non-metallic alignment tool for IF transformers.
- Repeat adjustments to insure good results.

Step	Dummy Antenna in Series with Signal Generator	Connection of Signal Generator (High Side)	Signal Generator Frequency	Receiver Gang Setting	Trimmer Description	Trimmer Designation	Type of Adjustment
1	.001 mfd. when using A. C. .1 mfd. when using Battery	Tuning condenser, antenna stator	455 KC	Gang fully open	2nd IF 1st IF	*A, B *C, D	Maximum output
2	"	"	1620 KC	"	Oscillator (on gang)	E	"
Install metal chassis cover.							
3	Loop of several turns of wire, or place generator lead close to receiver loop for adequate signal.	No physical connection (signal by radiation)	1400 KC	Tune in generator signal	Antenna (on gang)	F	"

*Adjustments A and C are made from other side of chassis.

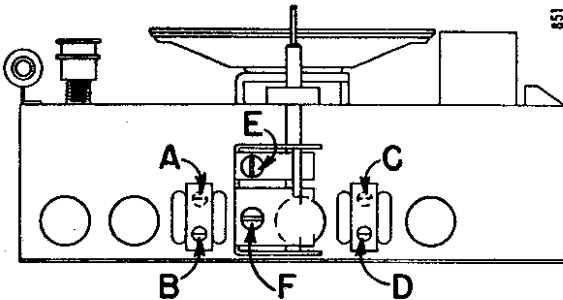

Trimmer Location, Underside of Chassis

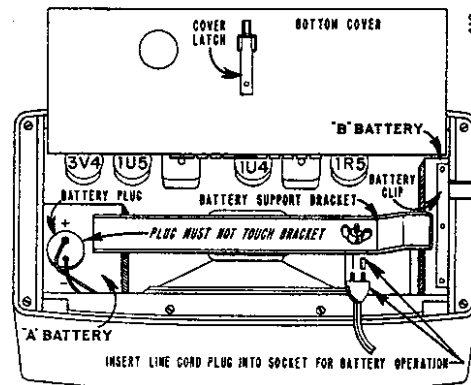

Tube and Battery Location

REPLACEMENT OF BATTERIES

Use replacement "A" and "B" batteries of the following types:
A Battery (7½ Volts): General 31, Eveready 717, Burgess C5, Ray-o-Vac 751C or equivalent.
B Battery (67½ Volts): General 108, Eveready 467, Burgess XX45, Ray-o-Vac 4367 or equivalent.

Electrical characteristics of recommended batteries for these models provide for equal life for both the "A" and "B" batteries. "A" batteries may give satisfactory performance as low as 5.5 volts; "B" batteries as low as 49.5 volts. Replace batteries when reception is weak and voltage has dropped below values given above.

To install replacement batteries, slide the cover latch and open the hinged bottom cover. Then remove the wing nut which holds the battery support bracket in place.

Disconnect battery connectors from old batteries. Batteries can easily be removed from the set by grasping them with long nose pliers or if necessary removing the cabinet bottom. Install new batteries so battery connectors are farthest away from the ends of the battery bracket. Batteries may become shorted if bracket touches connectors.

REPLACING TUBES

Tubes can most conveniently be removed or replaced by first removing the batteries and cabinet bottom. A miniature tube puller or extractor will be of help in facilitating tube replacement.

MODELS 4R11,
4R12, Ch. 4R1

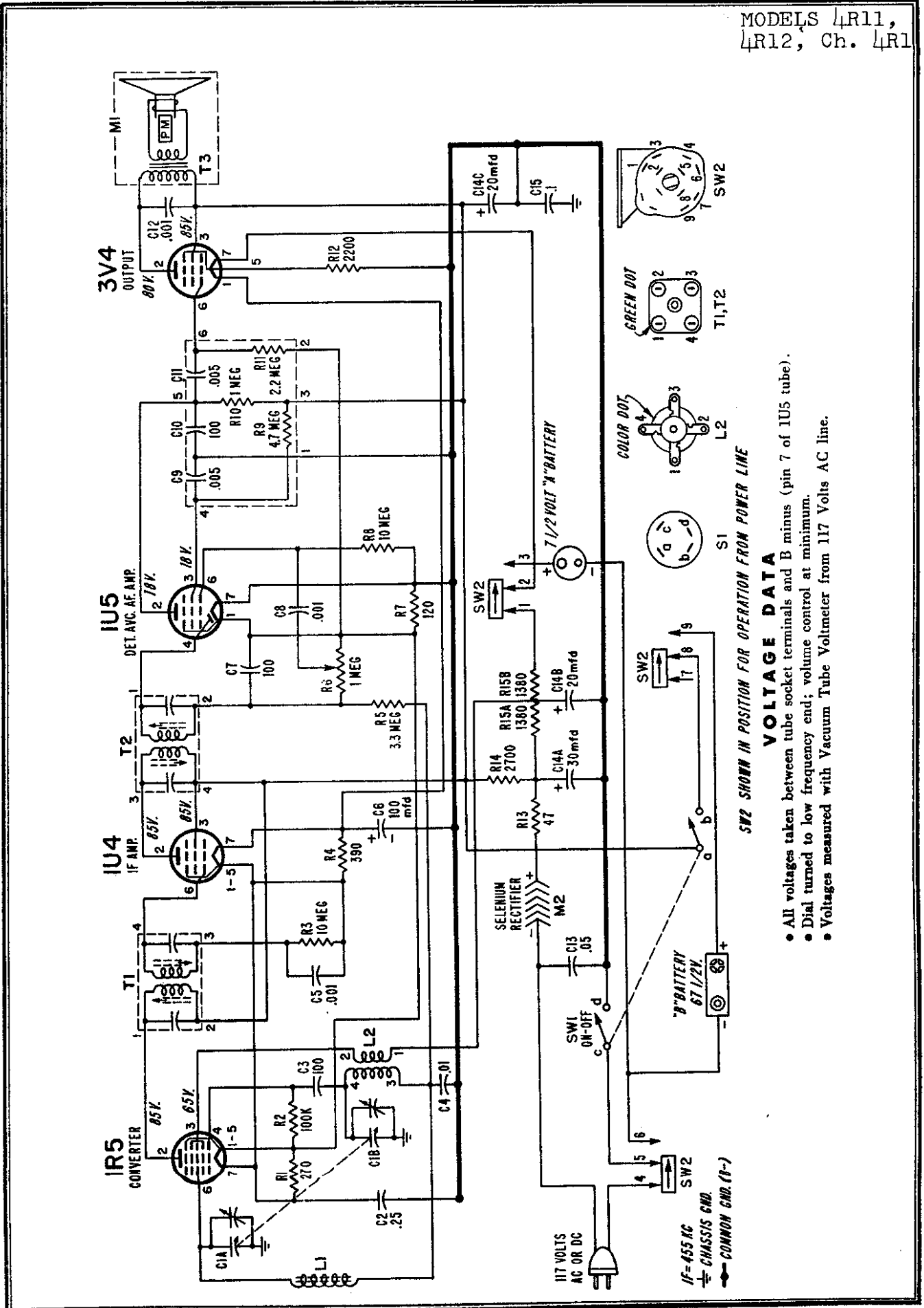

VOLTAGE DATA

- All voltages taken between tube socket terminals and B minus (pin 7 of 1U5 tube).
- Dial turned to low frequency end; volume control at minimum.
- Voltages measured with Vacuum Tube Voltmeter from 117 Volts AC line.

SW2 SHOWN IN POSITION FOR OPERATION FROM POWER LINE

MODELS 4R11,
4R12, Ch. 4R1

RESISTORS

Symbol	Description	Part No.
R1	270 ohms, 1/2 watt (was 180 ohms in early sets)	60B 8-271
R2	100,000 ohms, 1/2 watt	60B 8-104
R3	10 Megohms, 1/2 watt	60B 8-106
R4	390 ohms, 1/2 watt	60B 8-391
R5	3.3 megohms, 1/2 watt	60B 8-335
R6	1 megohm, Vol. Control	75B 1-37
R7	120 ohms, 1/2 watt	60B 8-121
R8	10 megohms, 1/2 watt	60B 8-106
*R9	4.7 megohms, 1/2 watt	
*R10	1 megohm, 1/2 watt	
*R11	2.2 megohms, 1/2 watt	
R12	2,200 ohms, 1/2 watt	60B 8-222
R13	47 ohms, 1 watt	60B 14-470
R14	2,700 ohm, 1 watt	60B 14-272
R15A	1380 ohms	Tapped Candohm. 61A 5-7
R15B	1380 ohms	

CONDENSERS

C1A	272.3 mmfd. max., Ant. Gang	68B 34
C1B	107.2 mmfd. max., Osc.	
C2	.25 mfd, 200 volts, paper	64B 1-28
C3	100 mmfd. ceramic	65B 6-3
C4	.01 mfd, 400 volts, paper	64B 1-25
C5	.001 mfd, min. ceramic	65B 6-41
C6	100 mfd, 25 volts, Electrolytic	67A 4-6
C7	100 mmfd, ceramic	65B 6-3
C8	.001 mfd, min. ceramic	65B 6-41
*C9	.005 mfd, min. ceramic	
*C10	100 mmfd, ceramic	
*C11	.005 mfd, ceramic	

*Part of couplet (part #63A4-3). Replace with exact duplicate or individual components. Note that numbers 1, 2, 3, 4, 5, 6, on schematic correspond to lead numbers printed on face of couplet.

C12	.001 mfd, min. ceramic	65B 6-41
C13	.05 mfd, 400 volts, paper	64B 8-28
C14A	30 mfd, 150 volts	Electrolytic 67C 7-41
C14B	20 mfd, 150 volts	
C14C	20 mfd, 150 volts	
C15	.1 mfd, 200 volts, paper	64B 1-30

COILS, TRANSFORMERS, ETC.

L1	Antenna, Rod (Ferro-Scope)	69C 120
L2	Coil, Oscillator	69A 39-4
T1	Transformer, 1st IF	72B 28-1
T2	Transformer, 2nd IF	72B 28-61
T3	Transformer, Output	98A 21
M1	Speaker (3 1/2" PM) and Output Trans.	78B 58-1
M2	Rectifier, Selenium	93A 1-6
SW1	Switch, On-Off, DPST, (less bracket)	77A 23
SW2	Switch, Power Change	77A 19-1
	*Couplet (includes R9, R10, R11, C9, C10, C11)	69A 4-3

PARTS FOR "HIDE-A-WAY" DIAL

Description	Part No.
Dial Cord (for volume control)	50A 1-3
Dial Scale	
Ebony for 4R11	22C 25-4
Maroon for 4R12	22C 25-1
Housing Assembly, Metal (for dial scale, includes hub and cam)	
Ebony for 4R11	A3264
Maroon for 4R12	A3256
Hub, Brass (for dial pointer)	27A 151
Pointer, Dial	25A 40
Pulley, Brass (volume tuning sleeve)	27A 149
Screw (#6x5/8 S.T.B.H.—for mtg. dial trim)	1A 71-9-71
Screw, Set (#4-40x5/16—for dial pointer hub)	1A 43-4
Spring, Hairpin (for mtg. dial ass'ly)	19A 2-6
Spring, Pointer Torsion	19A 63
Trim, Plastic (front bottom of dial housing)	
Ebony for 4R11	33B 60-1
Maroon for 4R12	33B 60-2

CABINET PARTS

Bottom, Cabinet (Base)	
Ebony for 4R11	
complete with metal door	A3270
plastic frame only	34D 35-2
Maroon for 4R12	
complete with metal door	A3260
plastic frame only	34D 35-1
Bracket, Handle Support (metal ends)	20B 14
Button, Push	
Ebony for 4R11	33A 61-1
Maroon for 4R12	33A 61-2

Description	Part No.
Cabinet (less bottom)	
Ebony for 4R11	A3271
Maroon for 4R12	A3273
Carb. Slide (for bottom door)	15A 291
Grille, Speaker (metal)	
Ebony for 4R11	36B 14-1
Gold for 4R12	36B 14
Handle, Carrying (plastic covering only)	
Ebony for 4R11	33A 58-1
Maroon for 4R12	33A 58-2
Hinge, Bottom Cover	37A 33
Knob	
Volume, Ebony	33C 56-2
Volume, Maroon	33C 56-4
Tuning, Ebony (includes compression ring)	A3272
Tuning, Maroon (includes compression ring)	A3274
Monogram ("Admiral")	26A 36
Ring, Compression (for tuning knob)	18A 5-5
Rivet, Shoulder	
with 5/64 shoulder	6A 4-2-2
with 7/64 shoulder	6A 4-12-71
with 15/64 shoulder	6A 4-11-2
with 3/32 shoulder	6A 4-7-71
Washer, Felt (for volume knob)	5A 4-17
Washer, Fibre (1 5/16" ODx 7/16" ID; for retaining volume pulley)	5A 1-17
Rubber Strap (for carrying handle)	12A 38
Screw	
#4x3/8 self tapping; for mtg. plastic base to cabinet	1A 69-6-71
#8-32x7/16; for mtg. handle and chassis	280-437-C2-71
Slide Arm (for bottom door)	15A 291
Spacer, Brass (for mtg. carrying handle)	23A 1-54
Spring, Support (for carrying handle)	18A 42

MISCELLANEOUS PARTS

Baffle, Speaker	43A 111
Bracket	
on-off switch mounting	15A 602
battery support	15A 603
button release	15A 599
trigger release and adjustment bracket assembly	A3253
(used in early sets only)	
trigger release bracket only	15A 600
volume pulley and bracket assy.	A3316
(used in late sets only)	
shield for gang	15A 618
cover for AC switch	15A 595
lever arm assembly	A3254
Carton and Fillers	44B 165
Clip, IF Transformer mounting	72B 28-10
Clip "B" Battery Connector	90A 5-3
Cover, Metal	
for chassis	14C 70
for AC switch	15A 595
Dial Cord (24" length needed)	50A 1-3
Insulator, Fibre (for mtg. rectifier)	32A 137
Manual	
Customers Instruction	41A 18-16
Service Manual	S322
Nut, Wing (#6/32 for battery support bracket)	2A 5-4-71
Plate, Electrolytic Mounting	67A 2-1
Plug, "A" Battery Connector	88A 4-6
Pulley, Brass	
mounts on volume control shaft	27A 150
drive for volume control cord	27A 149
riveted to lever arm	27A 146
Screw, Set	
for volume control pulley (#6-32x3/16)	1A 43-8
for pointer hub (#4-40x5/16)	1A 43-4
Snap Button (for mtg. AC switch cover)	13A 1-1-71
Socket, Tube	87A 3-4
Speed Nut, #5/32 (for trigger adjustment bracket)	2B 10-12
Spring, Coil	
for dial release bracket (1/2"x3/16" dia.)	19B 1-18
for lever arm (1 3/4" long)	19A 64
for dial cord (volume control) (7/16"x1/8" dia.)	19B 1-16
Spring, Hairpin (for retaining dial housing)	19A 2-6
Washer, Spring (5/16"ODx3/16"ID)	4A 6-13