

MODELS 4W18, 4W19, Ch. 4W1; 4T11, Ch. 4T1

**REMOVING AND INSTALLING CHASSIS**

To remove the chassis from the cabinet, remove the tuning knobs, cabinet bottom (base) and on the 4W1, the metal speaker grille. The speaker grille is removed by pulling it down away from the cabinet.

Release the chassis by removing the two mounting screws located in the top inside of the cabinet just below the handle brackets.

Install the chassis in cabinet in the same manner, being sure that the 1 5/16" diameter fibre washer (sleeve retainer) used on the 4W1 chassis is placed over the volume tuning sleeve just before sliding the 4W1 chassis into the cabinet.

Also, before tightening the two chassis mounting screws adjust the chassis for even spacing between all sides of the dial and the cut-out in the cabinet, otherwise binding may result.

**STRINGING VOLUME CONTROL DRIVE**

The illustrations below show the volume cord stringing system used on each of the chassis.

Before restringing the volume cord on these models, rotate volume control fully clockwise and, using a #6 Allen wrench, tighten the set screw on the volume control pulley, first being sure the cut-out slot(s) on the volume control pulley are in the position shown in each illustration. Loop the cord in the cut-out slots, winding 1 1/2 turns around the volume control pulley, and then winding 2 turns around the volume tuning sleeve on the 4W1 chassis or the volume-off knob on the 4T1 chassis. Loop the cord around the fibre pulley at other end of chassis. To prevent slipping, be sure that the volume control turns freely and that the dial cord tension spring has sufficient tension.

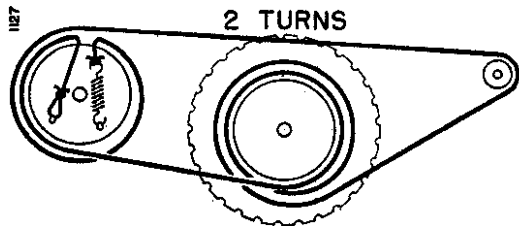

Chassis 4T1, Front View Showing Stringing

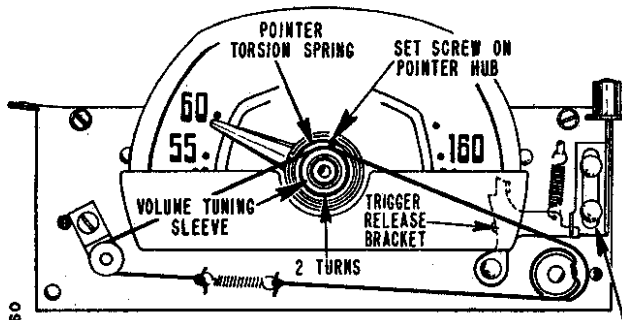

Chassis 4W1, Front View Showing Stringing

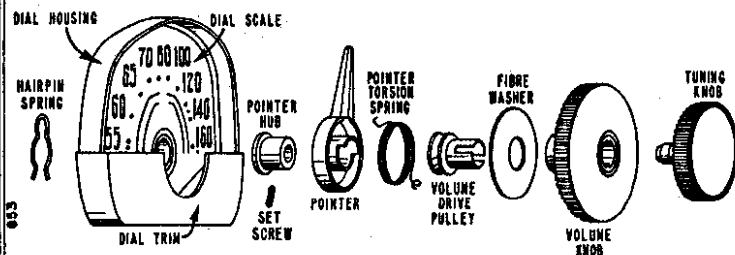

Chassis 4W1, Dial and Tuning Knob Assembly, Exploded View

**"HIDE-A-WAY" DIAL ON CHASSIS 4W1**

Illustrations below show front, rear and exploded views of dial mechanism. Follow the sequence shown in exploded view for disassembly or reassembly of the knobs, pointer or dial.

The "Hide-A-Way" dial mechanism is operated by the push button which works the trigger release bracket. The trigger bracket releases the dial assembly.

Thrust of the lever arm roller against the cam on back of the dial causes the dial to pop-up while a protruding edge on the lever arm simultaneously trips (turns on) the on-off switch.

Lever arm thrust is adjustable by attaching the far end of the lever arm spring to any of the holes spaced at different distances from the lever arm.

Rotating the dial fully to the left locks the dial into the cabinet and also trips (shuts-off) the on-off switch.

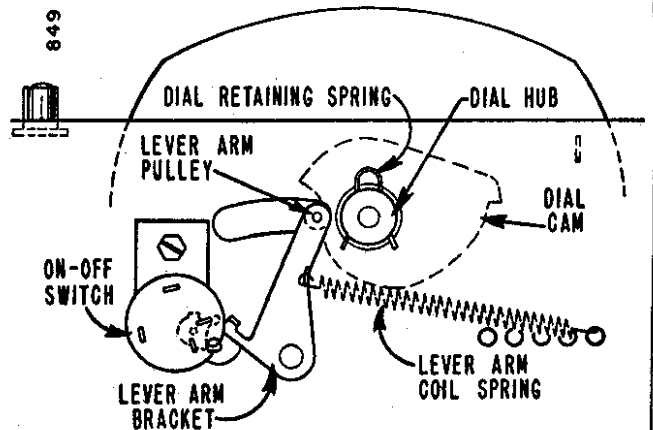

Chassis 4W1, "Hide-A-Way" Dial, Rear View

**DIAL POINTER ON CHASSIS 4W1**

The illustration shows an exploded view of the dial assembly and the sequence in which the pointer hub and torsion spring are to be assembled. When assembling the pointer torsion spring to the pointer, insert the rectangular end into the base of the pointer; compress the spring from about one-half to one turn in a clock-wise direction. Insert the rounded or looped end of the spring over the top end of the pointer set screw. Allow about 1/64" clearance between the inner turn of the pointer spring and pointer hub, or the pointer may bind or stick.

To adjust pointer, fully close the gang condenser. Set the end of the pointer over the two dots below 55 on the dial and tighten the pointer screw with a #4 Allen wrench. Important: Allow approximately 1/32" clearance between the hub on the pointer and the dial scale.

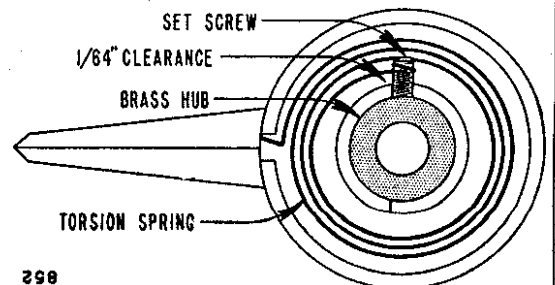

Chassis 4W1, Dial Pointer and Hub Assembly

MODELS 4W18, 4W19, Ch.  
4W1; 4T11, Ch. 4T1

### ALIGNMENT PROCEDURE

- Use battery power for alignment if fresh batteries are available.
- When using AC power, an isolation transformer should be used if available. If not using an isolating transformer, connect a .1 mfd. condenser in series with the signal generator low side to B minus (pin 7 of 1U5 tube).
- Batteries should be held in chassis during alignment.
- Set volume control full on.
- Connect output meter across speaker voice coil.
- Use lowest setting of signal generator capable of producing adequate output meter indication.
- Use a non-metallic alignment tool for IF transformers.
- Repeat adjustments to insure good results.

Step	Dummy Antenna in Series with Signal Generator	Connection of Signal Generator (High Side)	Signal Generator Frequency	Receiver Gang Setting	Trimmer Description	Trimmer Designation	Type of Adjustment
1	.001 mfd. when using A. C. .1 mfd. when using Battery	Antenna stator of tuning condenser	455 KC	Gang fully open	2nd IF 1st IF	*A, B *C, D	Maximum output
2	"	"	1620 KC	"	Oscillator (on gang)	E	"
Install metal chassis cover.							
3	Loop of several turns of wire, or place generator lead close to receiver for adequate signal pickup.	No actual connection (signal by radiation)	1400 KC	Tune in generator signal	Antenna (on gang)	F	"

\*Adjustments A and C are made from other side of chassis.

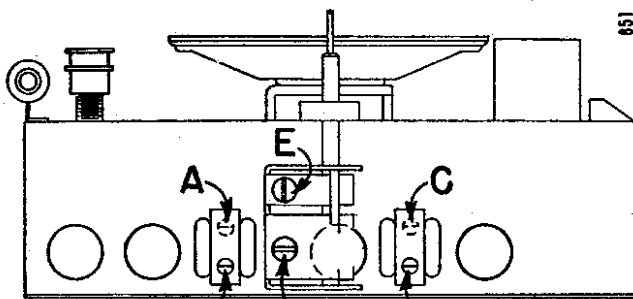

Trimmer Location, Underside of Chassis

### REPLACING OF BATTERIES

Use replacement "A" and "B" batteries of the following types:

**A Battery (7½ Volts):** General 31, Eveready 717, Burgess C5, Ray-o-Vac 751C or equivalent.

**B Battery (67½ Volts):** General 108, Eveready 467, Burgess XX45, Ray-o-Vac 4367 or equivalent.

Electrical characteristics of recommended batteries for these models provide for equal life for both the "A" and "B" batteries. "A" batteries may give satisfactory performance as low as 5.5 volts; "B" batteries as low as 49.5 volts. Replace batteries when reception is weak and voltage has dropped below values given above.

To install replacement batteries, slide the cover latch and open the hinged bottom cover. Then remove the wing nut which holds the battery support bracket in place.

Disconnect battery connectors from old batteries. Batteries can

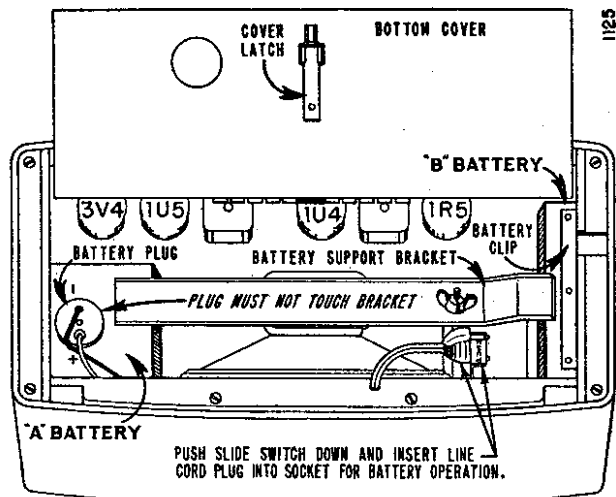

Tube and Battery Location

easily be removed from the set by grasping them with long nose pliers or if necessary removing the cabinet bottom. Install new batteries so battery connectors are farthest away from the ends of the battery bracket. Batteries may become shorted if bracket touches connectors.

### REPLACING TUBES

Tubes can most conveniently be removed or replaced by first removing the batteries and cabinet bottom. A miniature tube puller or extractor will be of help in facilitating tube replacement.

MODELS 4W18, 4W19,  
Ch. 4W1; 4T11, Ch.  
4T1

**VOLTAGE DATA**

Voltages shown on schematic diagram.

- All voltages taken between tube socket terminals and B minus (pin 7 of IU5 tube).
- Dial turned to low frequency end; volume control at minimum.
- Voltages measured with Vacuum Tube Voltmeter from 117 Volts AC line.

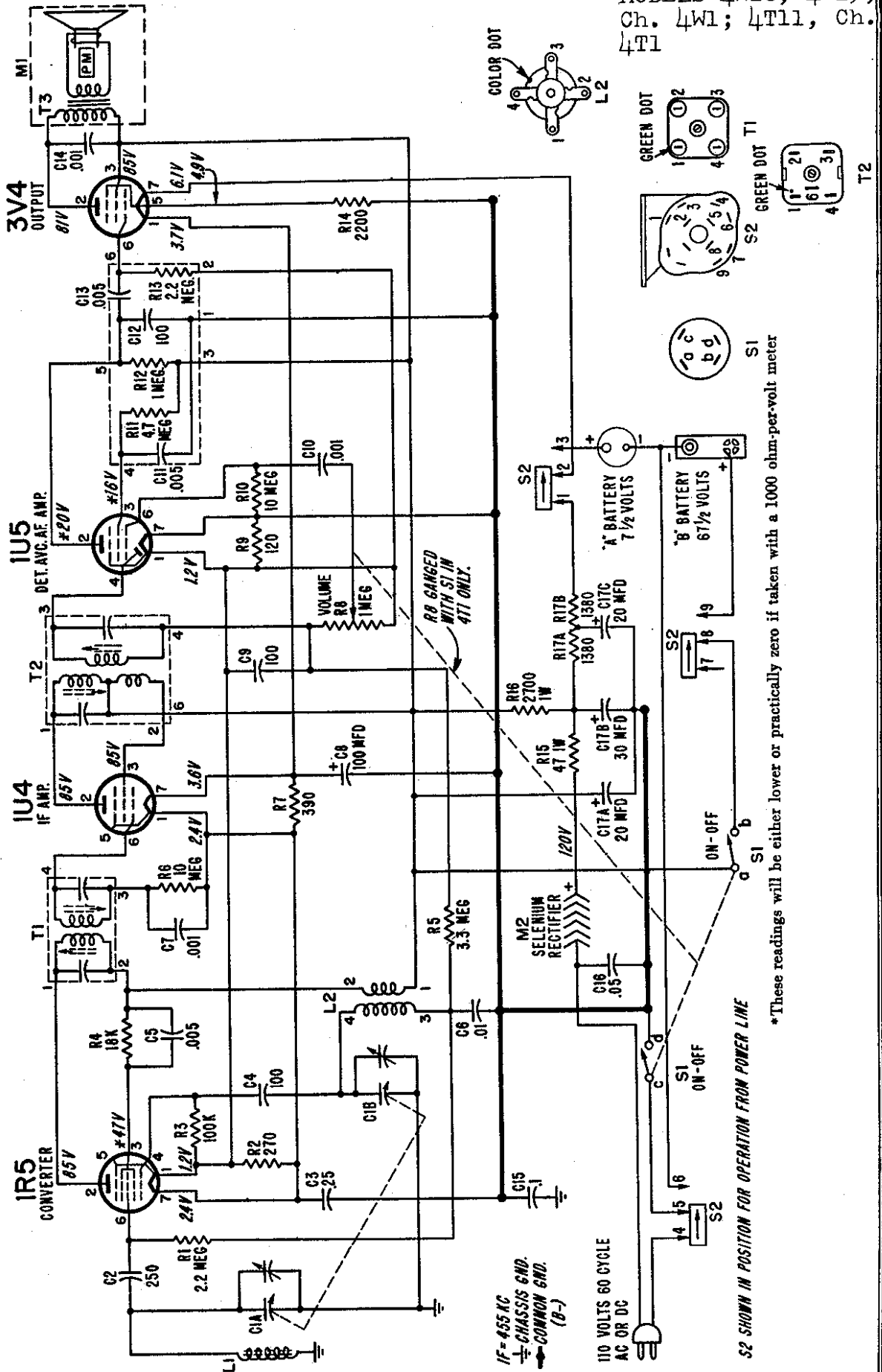

S2 SHOWN IN POSITION FOR OPERATION FROM POWER LINE

\*These readings will be either lower or practically zero if taken with a 1000 ohm-per-volt meter

MODELS 4W18, 4W19, Ch.  
4W1; 4T11, Ch. 4T1

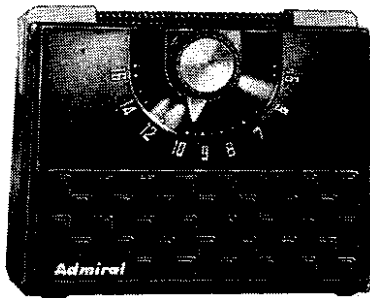

4T11

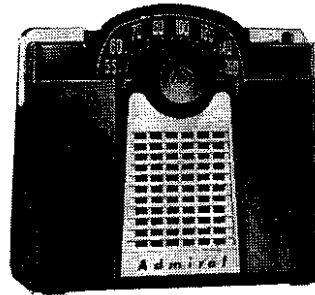

4W18, 4W19

**RESISTORS**

Symbol	Description	Part No.
R1	2.2 megohms, 1/2 watt	60B 8-225
R2	270 ohms, 1/2 watt	60B 8-271
R3	100,000 ohms, 1/2 watt	60B 8-104
R4	18,000 ohms, 1/2 watt	60B 8-183
R5	3.3 megohms, 1/2 watt	60B 8-335
R6	10 megohms, 1/2 watt	60B 8-106
R7	390 ohms, 1/2 watt	60B 8-391
R8	1 Megohm, Vol. Control	
	for 4T1	75B 1-43
	for 4W1	75B 1-37
R9	120 ohms, 1/2 watt	60B 8-121
R10	10 megohms, 1/2 watt	60B 8-106
R11	4.7 megohms, 1/5 watt	60B 14-470
R12	1 megohm, 1/5 watt	60B 14-272
R13	2.2 megohms, 1/5 watt	60B 8-222
R14	2,200 ohms, 1/2 watt	60B 14-470
R15	47 ohms, 1 watt	60B 14-272
R16	2,700 ohms, 1 watt	60B 14-272
R17A	1380 ohms 1/5 watt, Tapped	
R17B	1380 ohms (Candohm)	61A 5-7

**CONDENSERS**

Symbol	Description	Part No.
C1A	272 mmfd. max., Ant. Gang†	
C1B	107 mmfd. max., Osc. Gang†	
C2	250 mmfd., ceramic	65B 6-5
C3	.25 mfd, 200 volts, paper	64B 1-28
C4	100 mmfd., ceramic	65B 6-3
C5	.005 mfd, ceramic	65A 10-5
C6	.01 mfd, 400 volts, paper	64B 1-25
C7	.001 mfd, min. ceramic	65B 6-41
C8	100 mfd, 25 volts, Elec.	67A 4-6
C9	100 mmfd, ceramic	65B 6-3
C10	.001 mfd, min. ceramic	65B 6-41
*C11	.005 mfd, min. ceramic	
*C12	100 mmfd. ceramic	
*C13	.005 mfd, ceramic	
C14	.001 mfd, min. ceramic	65B 6-41
C15	.1 mfd, 200 volts, paper	64B 1-30
C16	.05 mfd, 400 volts, paper	64B 8-28
C17A	20 mfd, 150 volts	
C17B	30 mfd, 150 volts, Elect.	67C 7-41
C17C	20 mfd, 150 volts	

**COILS, TRANSFORMERS, ETC.**

Symbol	Description	Part No.
L1	Antenna, Rod	69C 120-1
L2	Coil, Oscillator	69A 39-5
T1	Transformer, 1st IF	72B 28-1
T2	Transformer, 2nd IF	72B 28-62
T3	Transformer, Output	98A 21
M1	Speaker (3 1/2" PM) and Output Trans.	78B 58-1
M2	Rectifier, Selenium	93A 1-6
S1	Switch, On-Off, DPST, (less bracket)	77A 23
S2	Switch, Power Change	77A 19-1
	*Couplate (includes R11, R12, R13, C11, C12, C13)	63A 4-3

**MISCELLANEOUS PARTS**

Description	Part No.
Baffle, Speaker	43A 111

Bracket (4W1 only)	
on-off switch mounting	15A 602
battery support	15A 603
button release	15A 599
trigger release bracket	15A 600
volume pulley and bracket ass'y.	A3316
shield for gang	15A 618
cover for AC switch	15A 595
lever arm assembly	A3254
Carton and Fillers	44B 165
Clip, IF Transformer mounting	72B 28-10
Clip "B" Battery Connector	90A 5-3
Cover, Metal for chassis	14C 70
Drum, Vol. control (4T1 only)	17A 30
Insulator, Fibre (for mtg. rectifier)	32A 137
Customers Instructions	
for 4W18, 4W19	41A 18-42
for 4T11	41A 18-38
Dial Cord (order length needed; 24" required for 4W1, 30" required for 4T1)	50A 1-3
Nut, Wing (#6/32 for battery support bracket)	2A 5-4-71
Plate, Electrolytic Mounting	67A 2-1
Plug, "A" Battery Connector	88A 4-6
Pulley, Brass	
mounts on volume control shaft (4W1 only)	27A 150-1
drive for volume control cord	27A 149-1
riveted to lever arm (4W1 only)	27A 146
Screw, Set	
for volume control pulley (#6-32x3/16)	1A 48-3
Socket, Tube	87A 3-4
Speed Nut, #5/32 (for trigger adjustment bracket)	2B 10-12
Speed Nut, #6 Escutcheon mtg. (4T1 only)	2B 10-9-68
Spring, Coil	
for 4W1 dial release bracket (1/2"x3/16" dia.)	19B 1-18
for 4W1 lever arm (1 3/4" long)	19A 64
for 4W1 dial cord (tension) (7/16"x1/8" dia.)	19B 1-16
for 4T1 dial cord (tension) (11/32"x9/64" dia.)	19B 1-17
Washer, Spring (5/16"ODx3/16"ID)	4A 6-13

**CABINET PARTS**

Description	Part No.
Bottom, Cabinet (Base)	
Ebony for 4T11	A3270
complete with metal door	A3270
plastic frame only	34D 35-2
Green for 4W18	A3493
complete with metal door	A3493
plastic frame only	34D 35-6
Tan for 4W19	A3494
complete with metal door	A3494
plastic frame only	34D 35-8
Bracket, Handle Support (metal ends)	20B 14
Button, Push	
Green for 4W18	33A 61-3
Tan for 4W19	33A 61-4
Cabinet (less bottom)	
Green for 4W18	34D 35-5
Tan for 4W19	34D 35-7
Ebony for 4T11	34D 44-1

Grille Cloth, Speaker (4W1)	36B 3-81
Grille, Plastic (gold) (4W1)	23C 95-1
Grille, Plastic (black) (4T1)	23C 94-1
Handle, Carrying (plastic covering only)	
Ebony for 4T11	33A 58-1
Green for 4W18	33A 58-3
Tan for 4W19	33A 58-4
Hinge, Bottom Cover	37A 33
Knob, Volume	
Green for 4W18	33C 58-8
Tan for 4W19	33C 58-10
Ebony for 4T11	33C 67-1
Knob, Tuning (includes compression ring)	
Green for 4W18	A3491
Tan for 4W19	A3492
Ebony for 4T11	A3473
Pointer, Dial	
for 4T1 chassis	25B 47-1
for 4W1 chassis	25A 40
Ring, Compression (for tuning knob)	
for 4W18, 4W19	19A 31-6
for 4T11	19A 31-7
Ring, Compression (for Pointer, 4T1)	19A 31-2
Rivet, Shoulder	
with 5/64 shoulder	6A 4-2-2
with 7/64 shoulder	6A 4-12-71
with 15/64 shoulder	6A 4-11-2
with 3/32 shoulder	6A 4-7-71
Rubber Strap, for carrying handle	
upper, with 13/32" holes	12A 38
lower, with 1/4" holes	12A 38-1
Screw	
#4x5/8 self tapping; for mtg. plastic base to cabinet	1A 69-6-71
#8-32x7/16; for mtg. handle and chassis	280-437-C2-71
Slide Arm (for bottom door)	15A 291
Spring, Support (for carrying handle)	18A 42
Washer	
felt, for 4W1 volume knob	5A 4-17
felt, for 4T1 volume knob	5A 4-8
fibre, for retaining volume knob on 4W1 (15/16"OD x 7/16"ID)	5A 1-17

**PARTS FOR "HIDE-A-WAY" DIAL in 4W1 Chassis**

Description	Part No.
Dial Scale	
Green for 4W18	22C 25-5
Tan for 4W19	22C 25-7
Housing Assembly, Metal (for dial scale, includes hub and cam)	
Green for 4W18	A3495
Tan for 4W19	A3496
Hub, Brass (for dial pointer)	27A 151
Pointer, Dial	25A 40
Pulley, Brass (volume tuning sleeve)	27A 149-1
Screw (#6x5/6 S.T.B.H.—for mtg. dial trim)	1A 71-9-71
Screw, Set (#4-40x5/16—for dial pointer hub)	1A 43-4
Spring, Hairpin (for mtg. dial assembly)	19A 2-6
Spring, Pointer Torsion	19A 63
Trim, Plastic (front bottom of dial housing)	
Green for 4W18	33B 60-3
Tan for 4W19	33B 60-4

†Use number 68B34-1 gang for 4W1 chassis, and number 68B41 gang for 4T1 chassis. Except for shaft lengths, these gang condensers are identical.

\*Part of couplate (part #63A4-3). Replace with exact duplicate or individual components. Note that numbers 1, 2, 3, 4, 5, 6, on schematic correspond to lead numbers printed on face of couplate.