

SPECIFICATIONS

Circuit: Superheterodyne using 4 miniature tubes and a selenium rectifier.

Frequency Range: Standard broadcast band, 535 to 1620 KC.

Intermediate Frequency: 455 KC.

Power Supply: Power line of 117 volts, 50 to 60 cycles AC or DC. Batteries using one 67½ volt "B" battery and one 7½ volt "A" battery.

Power Consumption: 20 watt on operation from power line.

Antenna: Built-in Ferro-Scope (iron core) antenna.

Speaker: 3½" PM, with a 1 oz. Alnico V magnet. Voice coil impedance, 3.2 ohms.

REPLACING BATTERIES

Replacement batteries of the following types may be used in this set:

"A" Battery (7½ Volts): General 31, Eveready 717, Burgess C5, Ray-O-Vac 751C or equivalent.

"B" Battery (67½ Volts): General 108, Eveready 467, Burgess XX45, Ray-O-Vac 4367 or equivalent.

The "A" and "B" batteries have been designed for equal life. Under normal operating conditions, battery life should be approximately 40 operating hours. The "A" battery may give satisfactory performance with voltage as low as 5.5 volts. The "B" battery may give satisfactory performance with voltage as low as 49.5 volts. Replace the batteries when the reception is weak and the battery voltage has dropped below values given above.

To install replacement batteries, slide the cover latch and open the hinged bottom cover. Then remove the wing nut which holds the battery support bracket in place.

Disconnect the battery connectors from the old worn out batteries. Batteries can easily be removed from the set by grasping them with long nose pliers or if necessary, removing the cabinet bottom. Install the new batteries so that the battery connectors are farthest away from the ends of the battery bracket. Batteries may become shorted if the bracket touches the connectors.

Note: It is important that the run-down batteries be removed from the set IMMEDIATELY because the chemical action inside of the cells will cause some batteries to leak when they are worn out. The acid which leaks from a run-down battery may damage parts of the set or the cabinet because of its corrosive action.

REPLACING TUBES

Tubes can most conveniently be removed or replaced by first removing the batteries and cabinet bottom. A miniature tube puller or extractor will be of help in facilitating tube replacement.

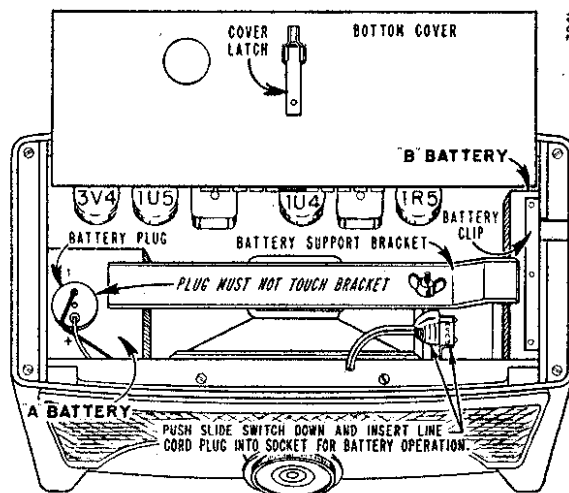

Tube and Battery Location

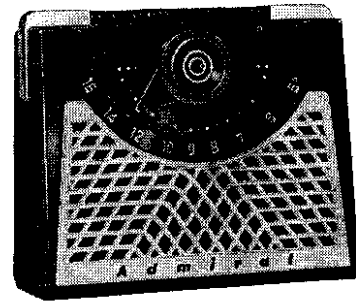

Models 4V12 Mahogany, 4V18 Green and 4V19 Ebony.

REMOVING AND INSTALLING CHASSIS IN CABINET

Removal of the chassis from the cabinet is not required when replacing tubes or batteries. It will, however, be necessary to remove the chassis for making alignment or for taking voltage readings. For taking voltage readings, it will also be necessary to remove the metal cover enclosing the underside of the chassis.

To remove the chassis from the cabinet, proceed as follows:

- (a) Remove the tuning knob, pointer hub and cabinet bottom (base). The speaker grille may be removed by pulling it down and away from the cabinet.
- (b) Remove the 2 chassis mounting screws located at the top inside of the cabinet, just below the handle brackets.
- (c) Carefully slide the chassis out of the cabinet, being careful not to damage the built-in iron core antenna or the speaker.

Install the chassis in the cabinet in the reverse order. A screwdriver with a magnetic blade or a screw holding type screwdriver will be of help in inserting the chassis mounting screws when installing the chassis in the cabinet.

STRINGING THE VOLUME CONTROL DRIVE CORD

The illustration below shows the volume control drive cord

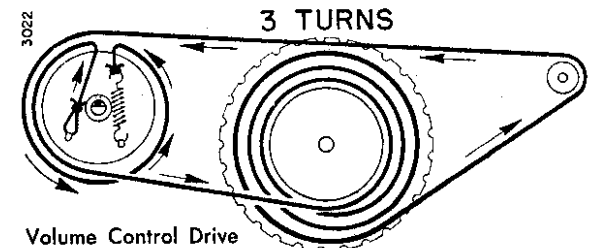

Volume Control Drive Cord Stringing

The arrows along the drive cord show the direction in which the volume control drive cord is strung.

Before stringing the drive cord, rotate the volume control fully counterclockwise until the on-off switch snaps in the off position. Place the volume knob over the gang condenser tuning shaft. To prevent the volume knob from slipping off during drive cord stringing, mount the dial pointer hub to the gang condenser tuning shaft. To prevent slipping of the volume control drive, it is important to maintain tension on the drive cord tension spring.

TRIMMER LOCATION

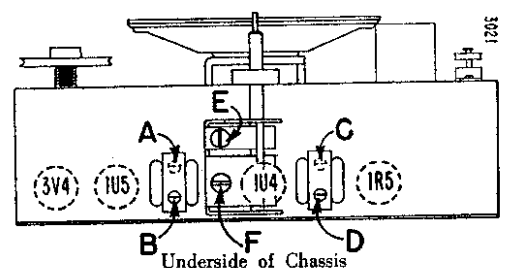

Adjustments A and C are made from other side of chassis.

MODELS 4V12, 4V18, 4V19, Ch. 4V1

ALIGNMENT PROCEDURE

- Use battery power for alignment if fresh batteries are available. If using AC power, an isolation transformer should be used if available. If an isolation transformer is not used, connect a .1 mfd. condenser in series with the signal generator low side to B minus (pin 7 of 1U5 tube.)
- Batteries should be held in place on the chassis during alignment.
- The metal chassis cover need not be removed during alignment.
- Set volume control full on.
- Connect output meter across speaker voice coil.
- Use lowest setting of signal generator capable of producing adequate output meter indication.
- Use a non-metallic alignment tool for IF transformers.
- Repeat adjustments to insure good results.

Step	Dummy Antenna in Series with Signal Generator	Connection of Signal Generator (High Side)	Signal Generator Frequency	Receiver Gang Setting	Trimmer Description	Trimmer Designation	Type of Adjustment
1	.001 mfd. when using AC. .1 mfd. when using Battery	Antenna stator of tuning condenser	455 KC	Gang fully open	2nd IF 1st IF	*A, B *C, D	Maximum output
2	.001 mfd. when using AC. .1 mfd. when using Battery	Antenna stator of tuning condenser	1620 KC	Gang fully open	Oscillator (on gang)	E	Maximum output
Install the metal chassis cover if removed during IF Alignment.							
3	Loop of several turns of wire, or place generator lead close to receiver for adequate signal pickup.	No actual connection (signal by radiation)	1400 KC	Tune in generator signal	Antenna (on gang)	F	Maximum output

*Adjustments A and C are made from other side of chassis.

RESISTORS

Symbol	Description	Part No.
R1	2.2 megohms, 1/2 watt	60B 8-225
R2	270 ohms, 1/2 watt	60B 8-271
R3	100,000 ohms, 1/2 watt	60B 8-104
R4	18,000 ohms, 1/2 watt	60B 8-183
R5	3.3 megohms, 1/2 watt	60B 8-335
R6	10 megohms, 1/2 watt	60B 8-106
R7	390 ohms, 1/2 watt	60B 8-391
R8	1 megohm, Vol. Control (R9 includes Switch S1)	75B 1-43
R9	120 ohms, 1/2 watt	60B 8-121
R10	10 megohms, 1/2 watt	
R11	4.7 megohms, 1/2 watt	
R12	1 megohm, 1/2 watt	
R13	3.3 megohms, 1/2 watt	
R14	2,200 ohms, 1/2 watt	60B 8-222
R15	47 ohms, 1 watt	60B 14-470
R16	2,700 ohms, 1 watt	60B 14-272
R17A	1380 ohms 1/2 watt, topped	
R17B	1380 ohms 1/2 watt, Candohm	61A 5-7

CONDENSERS

Symbol	Description	Part No.
C1A	272 mmfd, max. Ant. } gang	68B 41
C1B	107 mmfd, max. Osc. }	
C2	250 mmfd, ceramic	65C 6-5
C3	.25 mfd, 200 volts, paper	64B 1-28
C4	100 mmfd, ceramic	65C 6-3
C5	.005 mfd, ceramic	65C 10-5
C6	.01 mfd., 400 volts, paper	64B 1-23
C7	.001 mfd, min, ceramic	65C 6-41
C8	100 mfd, 25 volts, elect.	67A 4-6
C9	100 mmfd, ceramic	
C10	.001 mfd, min, ceramic	
C11	.01 mfd, min, ceramic	
C12	100 mmfd, ceramic	
C13	.005 mfd, ceramic	
C14	.001 mfd, min, ceramic	65C 6-41
C15	.1 mfd, 200 volts, paper	64B 1-30
C16	.047 mfd, 400 volts, paper	65A 13-5
C17A	20 mfd, 150 volts } elect	67C 7-41
C17B	30 mfd, 150 volts }	
C17C	20 mfd, 150 volts }	

COILS, TRANSFORMERS, ETC.

Symbol	Description	Part No.
L1	Antenna, Rod	69C 120-1
L2	Coil, Oscillator	69A 39-6
T1	Transformer, 1st IF	72B 28-1
T2	Transformer, 2nd IF	72B 28-62
T3	Transformer, Output	98A 21
M1	Speaker (3 1/2" PM) and Output Trans.	78B 58-1
M2	Rectifier, Selenium	93A 1-6
S1	Switch, On-Off	Part of R8
S2	Switch, Power Change	77A 19-1
	Couplate (includes R10, R11, R12, R13, C9, C10, C11, C12, C13)	63B 6-6

MISCELLANEOUS PARTS

Description	Part No.
Baffle, Speaker	43A 174
Bracket	
battery support	15A 603
volume pulley and bracket ass'y	A3316
shield for gang	15A 618
cover for AC switch	15A 595
Carton and Fillers	44B 165
Clip, IF Transformer Mounting	72B 28-10
Clip "B" Battery Connector	90A 5-3
Cover, Metal for chassis	14C 70
Drum, Vol. Control	17A 30
Insulator, Fibre (for mtg. rectifier)	32A 137
Customer Instructions	41B 20-3
Dial Cord (30" length needed)	50A 1-3
Nut, Wing (=6/32 for battery support bracket)	2A 5-4-71
Plate, Electrolytic Mounting	67A 2-1
Plug, "A" Battery Connector	88A 4-6
Hub, Brass	
mounts on volume control shaft	27A 153
Screw, Set	
for volume control drum (=6-32x3/16)	1A 43-8
Socket, Tube	87A 3-4
Washer, Spring (5/16"ODx3/16"ID)	4A 6-13

CABINET PARTS

Symbol	Description	Part No.
	Bottom, Cabinet (Base)	
	Mahogany for 4V12 complete with metal door	A3721
	plastic frame only	34D 35-4

Description Part No.

	Bottom, Cabinet (Base) contd.	
	Green for 4V18 complete with metal door	A3493
	plastic frame only	34D 35-6
	Ebony for 4V19 complete with metal door	A3270
	plastic frame only	34D 35-2
	Bracket, Handle Support (metal ends)	20B 14
	Cabinet (less bottom)	
	Mahogany for 4V12	34D 49-2
	Green for 4V18	34D 49-3
	Ebony for 4V19	34D 49-1
	Dial Pointer and Hub Assembly (includes compression ring)	
	Mahogany for 4V12	A3711
	Green for 4V18	A3712
	Red for 4V19	A3713
	Escutcheon Overlay, Plastic	23C 112-1
	Grille Cloth and Support Assembly	
	Mahogany for 4V12 and 4V19	AA227-2
	Green for 4V18	AA227-3
	Handle, Carrying (plastic covering only)	
	Mahogany for 4V12	33A 58-2
	Green for 4V18	33A 58-3
	Red for 4V19	33A 58-6
	Hinge, Bottom Cover	37A 33
	Knob, Volume	
	Mahogany for 4V12	33C 67-3
	Green for 4V18	33C 67-5
	Red for 4V19	33C 67-6
	Knob, Tuning (includes compression ring)	
	Mahogany for 4V12	A3707
	Green for 4V18	A3708
	Red for 4V19	A3709
	Ring, Compression (for tuning knob)	19A 31-7
	Ring, Compression (for pointer hub)	19A 31-2
	Rivet, Shoulder	
	with 7/64 shoulder	6A 4-12-71
	with 3/32 shoulder	6A 4-7-71
	Rubber Strap, for carrying handle upper, with 13/32" holes	12A 38
	lower, with 1/4" holes	12A 38-1
	Screw	
	=4x3/8 self tapping; for mtg. plastic base to cabinet	1A 69-6-71
	=8-32x7/16; for mtg. handle and chassis	280-437-C2-71
	Slide Arm (for bottom door)	15A 291
	Spring, Support (for carrying handle)	18A 42
	Washer, Felt (for volume knob)	5A 4-8

†Part of couplate (part #63B 6-6). Replace with extra duplicate or individual components. Note that numbers 1, 2, 3, 4, 5, 6, 7, 8, 9 on schematic correspond to lead numbers printed on face of couplate.

MODELS 4V12,
4V18, 4V19,
Ch. 4V1

VOLTAGE DATA

Voltages shown on schematic diagram:

- All voltages taken between tube socket terminals and B minus (pin 7 of 1U5 tube).
- Dial turned to low frequency end; volume control at minimum.
- Voltages measured with Vacuum Tube Voltmeter from 117 Volts AC line.

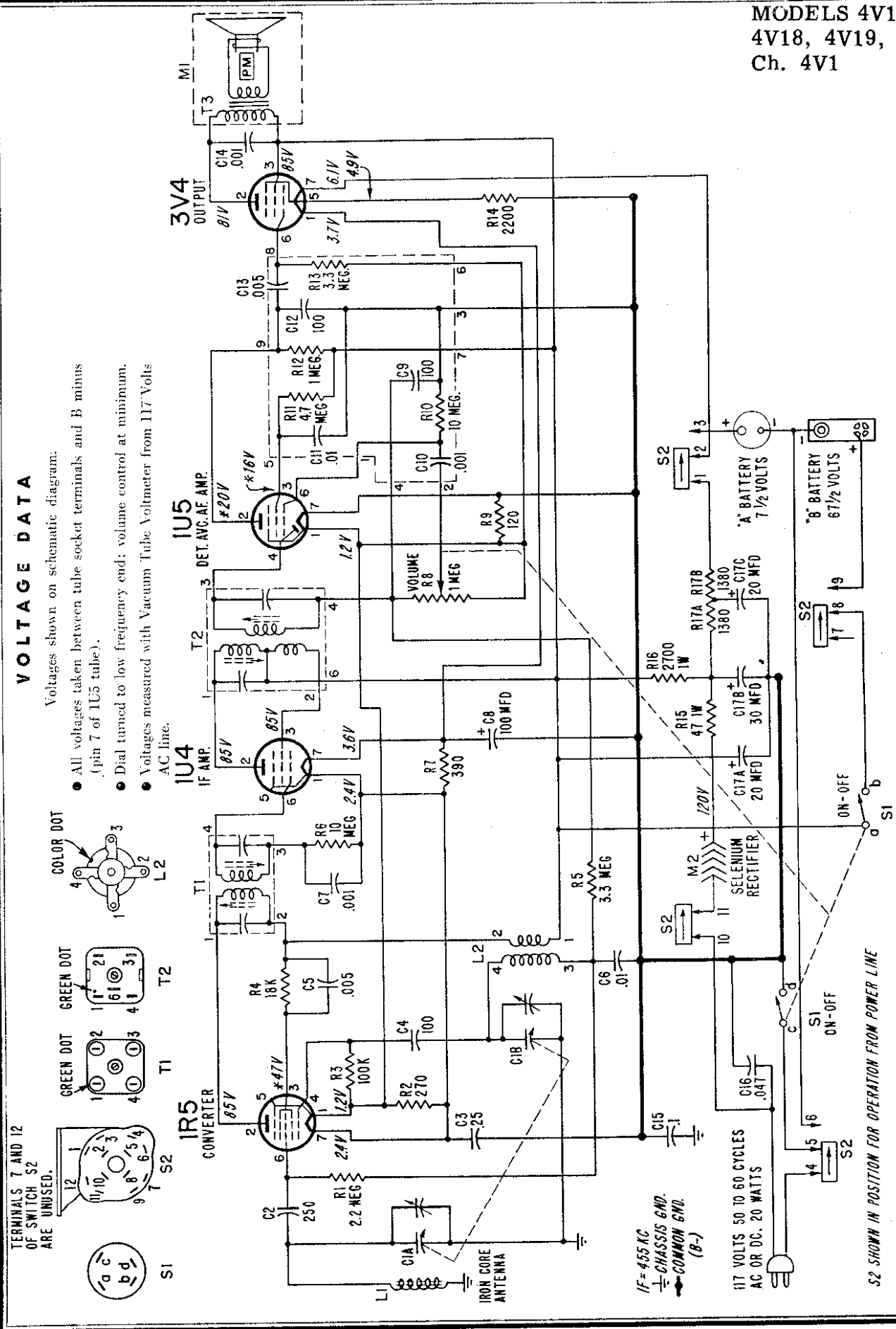

*These voltage readings will be either lower or practically zero if taken with a 1000 ohm-per-volt meter.