

Models 4X11 Ebony, 4X12 Maroon,  
4X18 Green and 4X14 Gray

### GENERAL

This receiver incorporates the latest radio circuitry with printed circuit technique. The printed circuit used in this receiver replaces the hookup wire used in earlier receivers. See figures 1 and 2. The printed circuit is permanently fixed to the plastic chassis base by a photoengraving process. This new method of circuitry offers uniform chassis wiring, fewer wiring troubles and simplifies circuit tracing and trouble shooting. All circuit components are standard size and design. For servicing convenience, all parts are mounted on the top of the chassis; see figure 2. Audio circuit parts are contained in a printed circuit couplate, part number 63B6-6.

In general, trouble shooting and parts replacement will be the same as for receivers wired with hookup wire. However, when servicing, it is important to read the service information given in this manual concerning servicing technique for printed circuit receivers. A top view of the chassis is shown in figure 2. A bottom view of the chassis is shown in figure 1.

### REPLACING PARTS

To avoid damaging printed circuits with excessive heat, use a soldering iron (60 watts maximum) with a small tip when replacing parts.

To remove defective parts, apply the tip of the soldering iron to the connection at the underside of the chassis. Keep soldering iron on connection just long enough to melt the solder, then quickly tap the chassis against the service bench to shake the solder away from the connection. After the solder is removed, untwist or separate connections. A pick will be helpful for untwisting or separating connections. After disconnecting wires or lugs, carefully remove parts from the top of the chassis.

### SPECIFICATIONS

**Circuit:** Superheterodyne using 4 miniature tubes. See additional circuit information

**Frequency Range:** Standard broadcast band, 535 to 1620 KC.

**Intermediate Frequency:** 455 KC.

**Power Supply:** Two 1½ volt "A" batteries and one 67½ volt battery.

**Antenna:** Built-in Ferro-Scope (iron-core) antenna.

**Speaker:** 3½" PM, with Alnico V magnet. Voice coil impedance, 3.2 ohms.

Before installing replacement parts, clean the solder from the connection, so the wires or lugs may pass through the holes in the chassis panel. To avoid running solder into adjoining circuits, use as little solder as necessary.

For quick replacement, resistors and capacitors may be replaced by clipping out the defective part and soldering the new part to the connecting wires remaining from the original part.

An open or damaged section of the printed circuit can be repaired by soldering a jumper of ordinary hookup wire across the connection points. To avoid need for complete tube socket replacement, defective tube socket terminals may be replaced individually. Tube socket terminals are available under part number 87A35-2.

Note: The tubular shield (center connection) at the bottom of each tube socket must be securely soldered to the printed circuit, otherwise hum or oscillation will result.

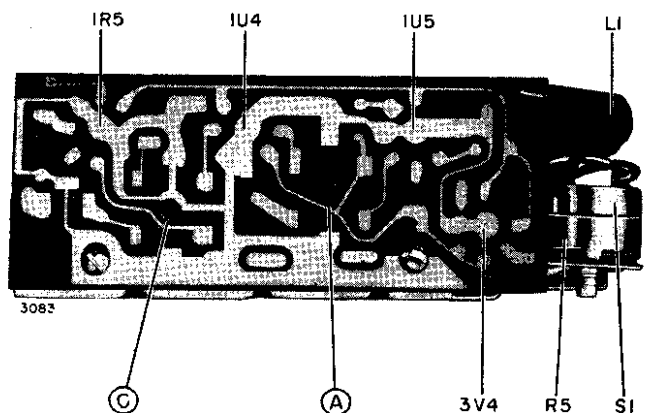

Figure 1. Bottom View of Chassis.

### ALIGNMENT PROCEDURE

- Use FRESH batteries when alignment adjustments are made.
- Connect output meter across speaker voice coil.
- Turn receiver volume control full on.
- Use lowest output of signal generator necessary for producing adequate output meter indication and then proceed as outlined in chart below.
- Use a NON-METALLIC alignment tool for IF transformers.
- Repeat adjustments to insure good alignment.

Step	Dummy Antenna in Series with Signal Generator	Connection of Signal Generator (High Side)	Signal Generator Frequency	Receiver Gang Setting	Trimmer Description	Trimmer Designation	Type of Adjustment
1	.1 mfd. capacitor	Stator of antenna tuning capacitor	455 KC	Gang fully open	2nd IF 1st IF	*A, B *C, D	Maximum Output
2	.1 mfd. capacitor	Stator of antenna tuning capacitor	1620 KC	Gang fully open	Oscillator (on gang)	E	Maximum Output
3	Loop of several turns of wire or place generator lead close to receiver loop for adequate signal pickup.	No actual connection (signal by radiation)	1400 KC	Tune in generator signal	Antenna (on gang)	F	Maximum Output

\*Adjustments A and C made from the underside of the chassis. To avoid splitting the slotted head of powdered iron core tuning slugs in IF transformers, use an alignment tool with a blade 3/32" wide.

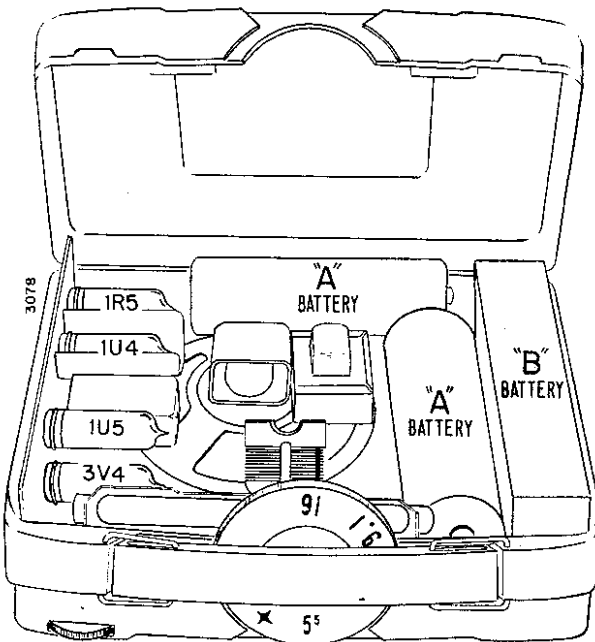
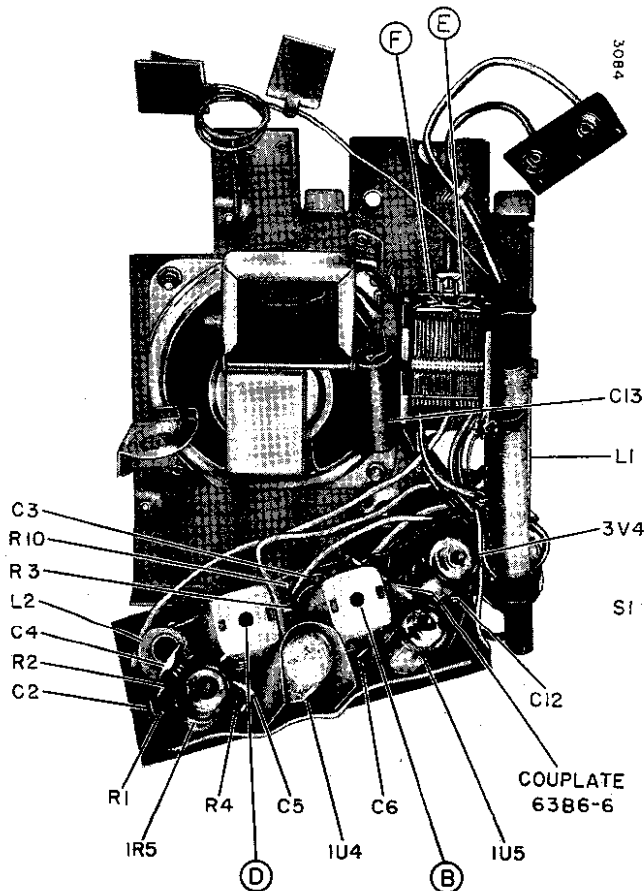

#### REPLACING BATTERIES

In normal use, batteries for this set should furnish about 80 operating hours. Batteries of the type given below, or an equivalent substitute may be used in this set.

"A" Battery (1½ volts): R.C.A. VS236, Burgess 21R, Eveready 964.

"B" Battery (67½ volts): R.C.A. VS216, Burgess P45, Eveready 477.

Figure 2. Top View of Chassis. Location of Components and Alignment Adjustments Shown. Adjustments A and C made from underside. See figure 1.

**CAUTION**

To avoid damage to test equipment or to the printed circuit, do not place the chassis directly on a metal service bench, tools or other metal objects.

When making voltage or resistance measurements, use test leads with needle point prods to avoid short circuits between sections of the printed circuit wiring.

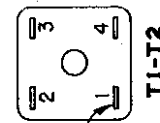
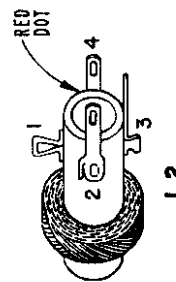
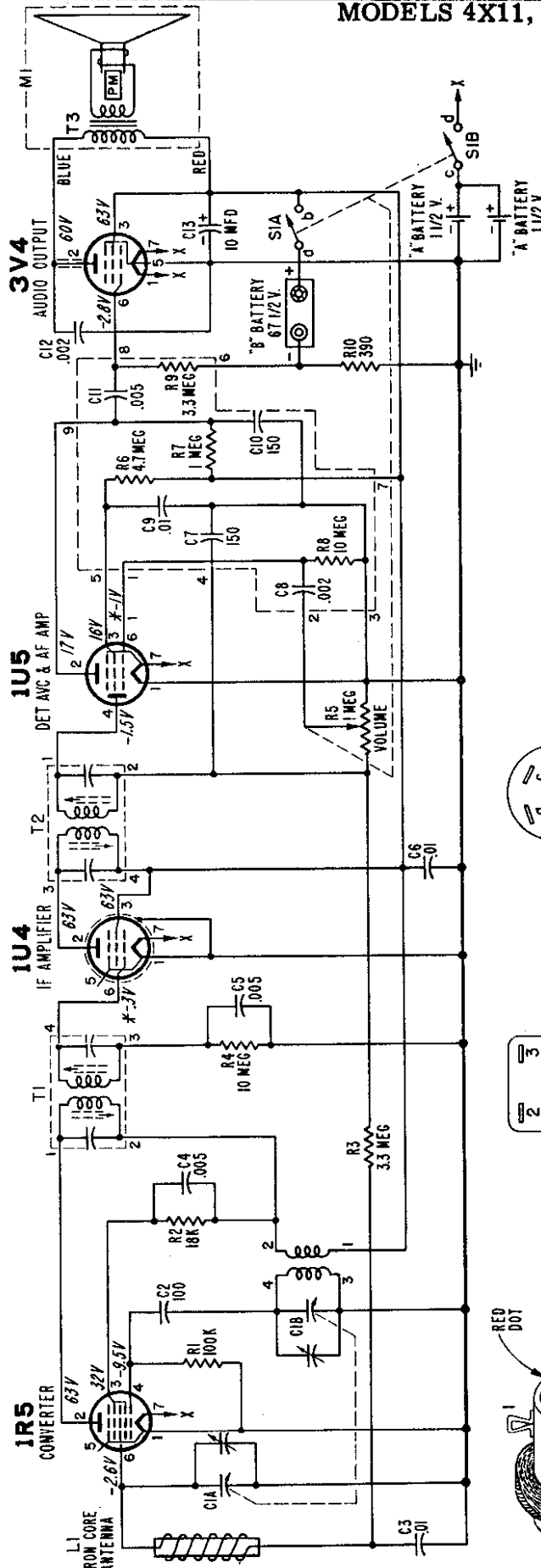

\*These voltage readings will be either lower or practically zero if taken with a 1000 ohms-per-volt meter.

**VOLTAGE DATA**

- All readings made between tube socket terminals and chassis

- Dial turned to low frequency end; volume control at minimum.
- Voltages measured with fresh batteries.
- Voltages measured with Vacuum-tube Voltmeter.

MODELS 4X11, 4X12, 4X18, 4X19, Ch. 4X1

**RESISTORS**

Symbol	Description	Part No.
R1	100,000 ohms, 1/2 watt.....	60B 8-104
R2	18,000 ohms, 1/2 watt.....	60B 8-183
R3	3.3 megohms, 1/2 watt.....	60B 8-335
R4	10 megohms, 1/2 watt.....	60B 8-106
R5	1 megohm, Volume control..	75B 19-1
	(includes switch S1)	
†R6	4.7 megohms	
†R7	1 megohm	
†R8	10 megohms	
†R9	3.3 megohms	
R10	390 ohms, 1/2 watt.....	60B 8-391

**CAPACITORS**

Symbol	Description	Part No.
C1A	197 mmfd, max, ant. } gang..	68B 56
C1B	97.8 mmfd, max, osc. }	
C2	100 mmfd, ceramic.....	65C 6-3
C3	.01 mfd, ceramic.....	65A 10-3
C4	.005 mfd, ceramic.....	65A 10-5
C5	.005 mfd, ceramic.....	65A 10-5
C6	.01 mfd, ceramic.....	65A 10-3
†C7	150 mmfd	
†C8	.002 mfd	
†C9	.01 mfd	
†C10	150 mmfd	
†C11	.005 mfd	
C12	.002 mfd, ceramic.....	65B 9-37
C13	10 mfd, 75 volts, electrolytic	67A 4-11

**COILS, TRANSFORMERS, ETC.**

Symbol	Description	Part No.
L1	Antenna, Iron Core.....	69B 166-1
L2	Coil, Oscillator.....	69A 165-1
T1	Transformer, 1st IF.....	72B 28-64
T2	Transformer, 2nd IF.....	72B 28-64
T3	Transformer, Output.....	98A 21
M1	Speaker (3 1/2" PM) and Output Transformer.....	78B 83-1
S1	Switch, On-Off.....	Part of R5
	Couplate.....	63B 6-6
	(includes R6, R7, R8, R9, C7, C8, C9, C10, C11)	

**MISCELLANEOUS PARTS**

Description	Part No.
Bracket	
"A" Battery Ground.....	18A 70
"A" Battery Ground.....	18A 74
Carton and Fillers.....	44C 288
Clip, Fuse (for cabinet catch).....	84A 10-16
Connector	
"A" Battery.....	18A 72
"B" Battery.....	90A 6-1
Nut (for mtg. speaker).....	2A 1-14-24
Lockwasher (for mtg. speaker).....	3B 1-26-24

Description	Part No.
Screw	
for mtg. antenna, #6-32 x 1/8	
BH MS.....	265-125-C2-24
for mtg. fuse clip, #4-40 x 3/16	
RH MS.....	40-187-C2-24
for mtg. gang, #6-32 x 3/16	
BH MS.....	265-187-C2-24
for mtg. chassis base, #6-32 x 1/4	
RH MS.....	260-250-C2-24
for mtg. speaker, #8-32 x 5/16	
BH MS.....	85-312-C2-70
Socket, Tube.....	87A 35-1
Terminal, Tube Socket.....	87A 35-2
Terminal Lug.....	9B 1-3

**CABINET PARTS**

Description	Part No.
Bracket, Handle Support.....	19A 76
Cabinet, Front (includes grille)	
ebony.....	34D 64-1
maroon.....	34D 64-3
green.....	34C 64-5
gray.....	34D 64-7
Cabinet, Rear	
ebony.....	34D 64-2
maroon.....	34D 64-4
green.....	34D 64-6
gray.....	34D 64-8
Compression Ring (for tuning knob)	19A 31-10
Eyelet (for cabinet catch).....	6B 3-31
Grille Cloth and Baffle.....	AA 227-7
Handle, Plastic	
ebony.....	37B 87-1
maroon.....	37B 87-2
green.....	37B 87-3
gray.....	37B 87-4
Hinge, Spring.....	19A 72-1
Knob, Tuning	
ebony.....	33B 104-1
maroon.....	33B 104-3
green.....	33B 104-5
gray.....	33B 104-7
Knob, Volume	
ebony.....	33B 104-2
maroon.....	33B 104-4
green.....	33B 104-6
gray.....	33B 104-8
Screw	
for mtg. chassis, #4-40 x 3/16	
BH MS.....	245-187-C2-24
for mtg. eyelet, #6-32 x 3/8	
BH MS.....	60-375-C2-24
for mtg. Volume knob, #4-40 x 5/16	
BH MS.....	245-312-C2-24

†Part of couplate, part number 63B 6-6. Numbers on schematic correspond to lead numbers on couplate.