

A. H. GREBE & CO., Inc.

MODEL Synchrophase AC-6 Schematic

WIRING DIAGRAM FOR GREBE SYNCHROPHASE AC SIX RECEIVER

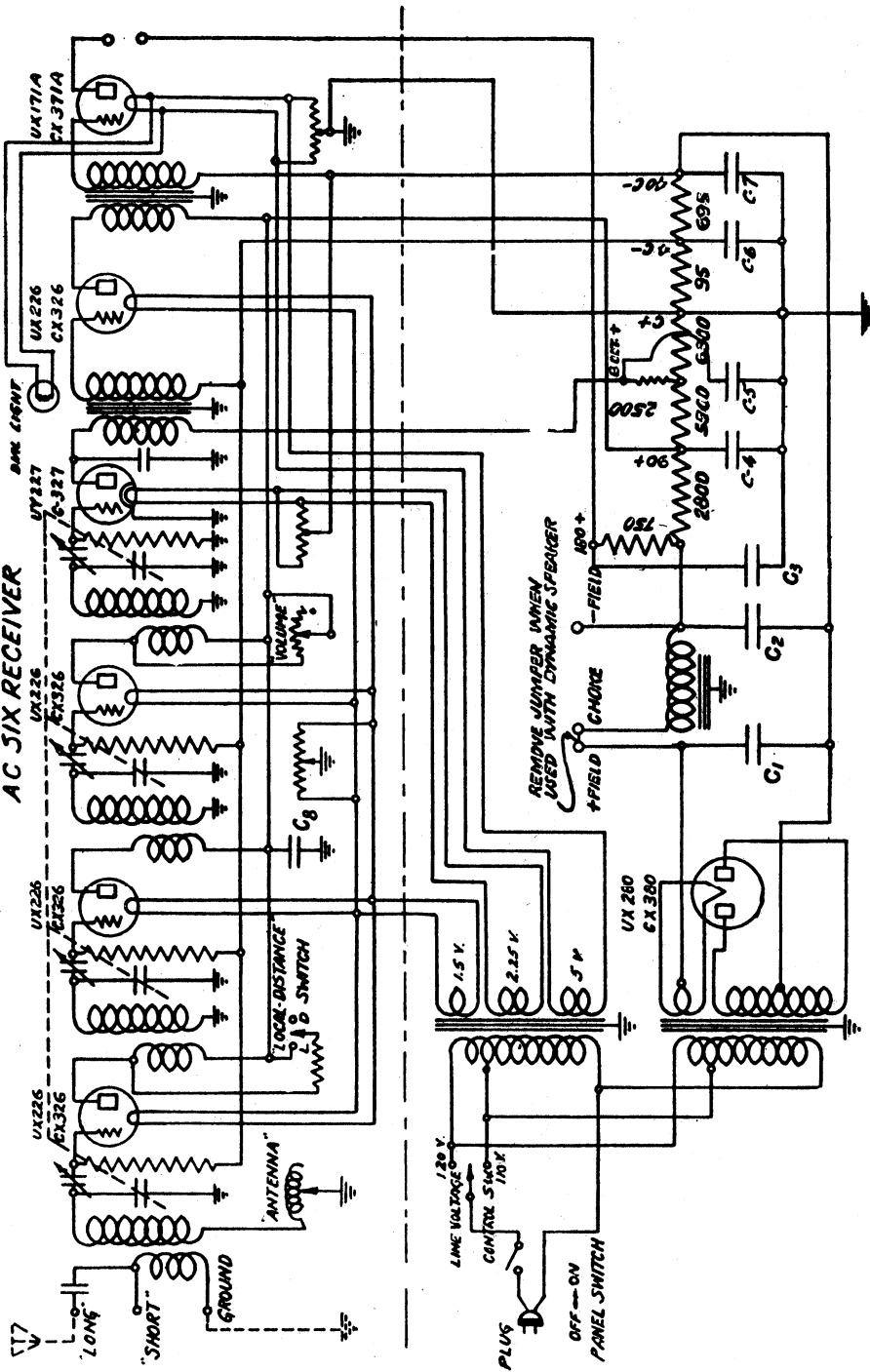

(A.C.)

Synchrophase AC6

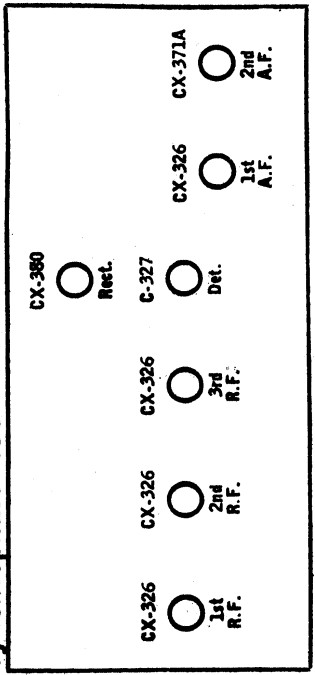

GREBE—Type A. C. 6
Line Voltage 120—Set on 120 Volt Tap

TUBE NO. IN CHASSIS	POSITION OF TUBE	TUBE OUT		TUBE IN TESTER		REPLACE PLUS IN SOCKET OF SET		SCREEN		
		A VOLTS	B VOLTS	A VOLTS	B VOLTS	CATHODE RESISTOR (OHMS)	NORMAL PLATE VOLTAGE (VOLTS)		PLATE RESISTOR (OHMS)	
226	1st RF	1.5	105	1.5	105	—	7.5	7.5	0	
226	2nd RF	1.5	105	1.4	100	—	7.5	7.5	0	
226	3rd RF	1.5	105	1.4	100	—	7.5	7.5	0	
227	Det.	3.5	50	2.2	45	—	2.5	2.5	0	
226	1st AF	1.5	100	1.4	100	4.5	R-60	3.8	6.0	4.2
171A	2nd AF	5.5	280	5.2	195	40.0	80.0	85.0	5.0	
260	Rect.	5.5	—	5.5	—	—	—	—	—	—

**MODEL Synchrophase AC-6
Power Unit
Chassis
Two Types**

A. H. GREBE & CO., Inc.

