

181

SERVICE MANUAL

MODEL NO.

STEREO CASSETTE DECK AD-3700



Code No. 04-370-000-58

TYPE. H, HU, E, K, G

DATE OF ISSUE 3/1982

SPECIFICATIONS

Semiconductors:	13 ICs, 113 transistors, 75 diodes, 13 LED's	(WTD-A)	More than 62/68 dB (METAL, DOLBY NR B-type/C-type)
Power supply:	H, HU model AC 120V/220V/240V switchable 50/60 Hz E model AC 220V, 50/60 Hz K, G model AC 240V, 50/60 Hz		More than 62/ 68 dB (CrO ₂ , DOLBY NR B-type/C-type)
Power consumption:	24W	Channel separation:	More than 60/66 dB (LH, DOLBY NR B-type/C-type)
Dimensions:	420(W) x 110(H) x 265(D) mm	(1 kHz, 0 VU)	More than 30 dB
Weight:	5.1 kg	Cross talk:	More than 60 dB
Track type:	4 tracks 2 channel	(1 kHz, 0 VU)	
Tape speed:	4.8 cm/s ± 1.5%	Erasing ratio:	More than 60 dB
Wow an flutter:	Less than 0.028% (WRMS)	(135 Hz, 0 VU + 10 dB)	
Automatic stop system:	Full auto stop	Bias frequency:	85 kHz
Automatic shut-off action time:	Less than 5s.	Frequency response:	METAL 20 ~ 20,000 Hz
Pinch roller pressure:	T350 ± 30g (3.43 ± 0.30N) S180 ± 20g (1.76 ± 0.20N)	Motor:	CrO ₂ 20 ~ 19,000 Hz
Take-up torque:	50 ± 10g - cm (0.49 ± 0.098 m N.m)	DC Servomotor for capstan DC motor for reels	LH ² 20 ~ 17,000 Hz
FF & rewind torque:	150 ⁺⁵⁰ ₋₃₀ g - cm (1.47 ^{+0.49} _{-0.294} m N.m)	Head:	DX head (for Rec/Pb)
FF & rewind time:	70 ± 10s. (C-60)	Inputs:	MIC max. sensitivity 0.3 mV (200Ω ~ 10 kΩ suitable)
Playback output:	730 ± 60 mV (LINE)		LINE IN max. sensitivity 50 mV (Optimum load impedance more than 50 kΩ)
Playback noise:	Less than 1.6 mV (CrO ₂) Less than 2.0 mV (METAL) Less than 2.7 mV (LH)	Outputs:	LINE OUT Standard level 0.55V (0 VU) (Optimum load impedance more than 50 kΩ)
Rec./PB output:	0VU ⁺⁶⁰ ₋₄₀ mV (LINE)		PHONES 8Ω
Rec./Pb distortion:	Less than 1.5% (METAL) Less than 1.5% (CrO ₂) Less than 1.5% (LH)		
Rec./Pb SN ratio:	More than 50/54 dB (METAL, DOLBY NR B-type OFF/ON) More than 50/54 dB (CrO ₂ , DOLBY NR B-type OFF/ON) More than 48/52 dB (LH, DOLBY NR B-type OFF/ON)		

- Specifications and external appearance are subject to change without notice due to product improvement.
- Noise reduction system manufactured under license from Dolby Laboratories Licensing Corporation.
- Dolby and the  symbol are trademarks of Dolby Laboratories Licensing Corporation.

AIWA Co., Ltd. Tokyo Japan

181

DISASSEMBLY INSTRUCTIONS

1. Removing the Cabinet, Steel

1) Remove 6 screws. (See figure 1)

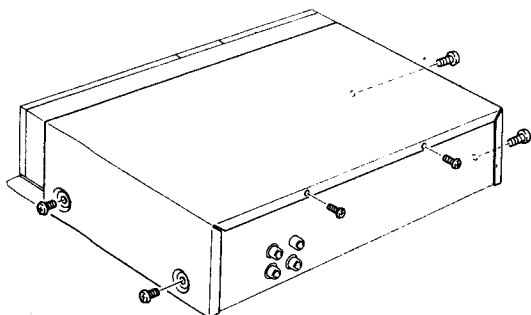

Fig. 1

3) Remove 8 screws. (See figure 4)

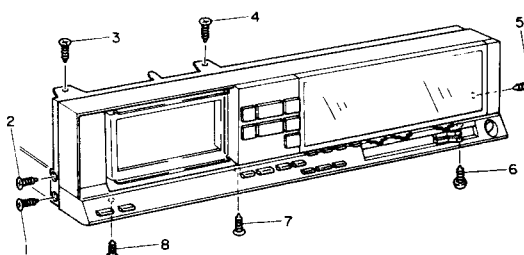

Fig. 4

2. Removing the Front, Panel

1) After depress eject button to open cassette box, pull cassette lid to remove in the direction of arrow. (See figure 2)

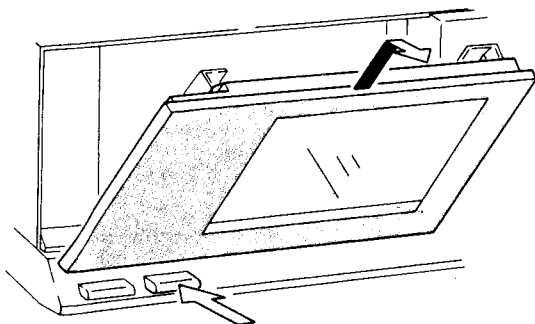

Fig. 2

2) Remove 2 screws to take off cassette plate. (See figure 3)

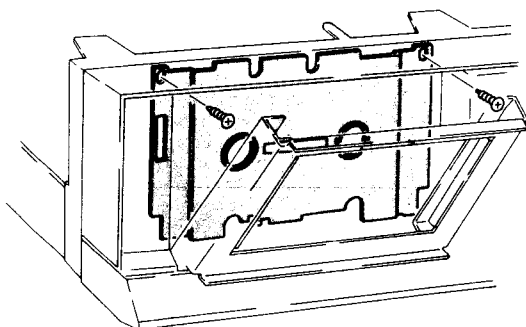

Fig. 3

3. Removing the Mechanism

1) Remove 2 screws. (See figure 5)

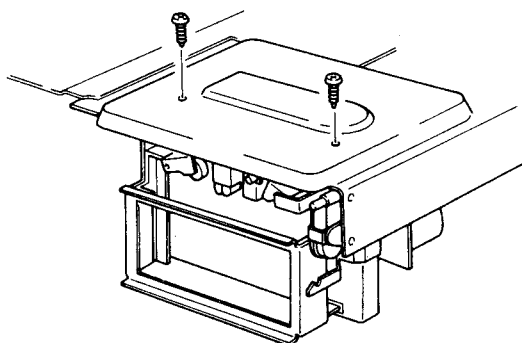
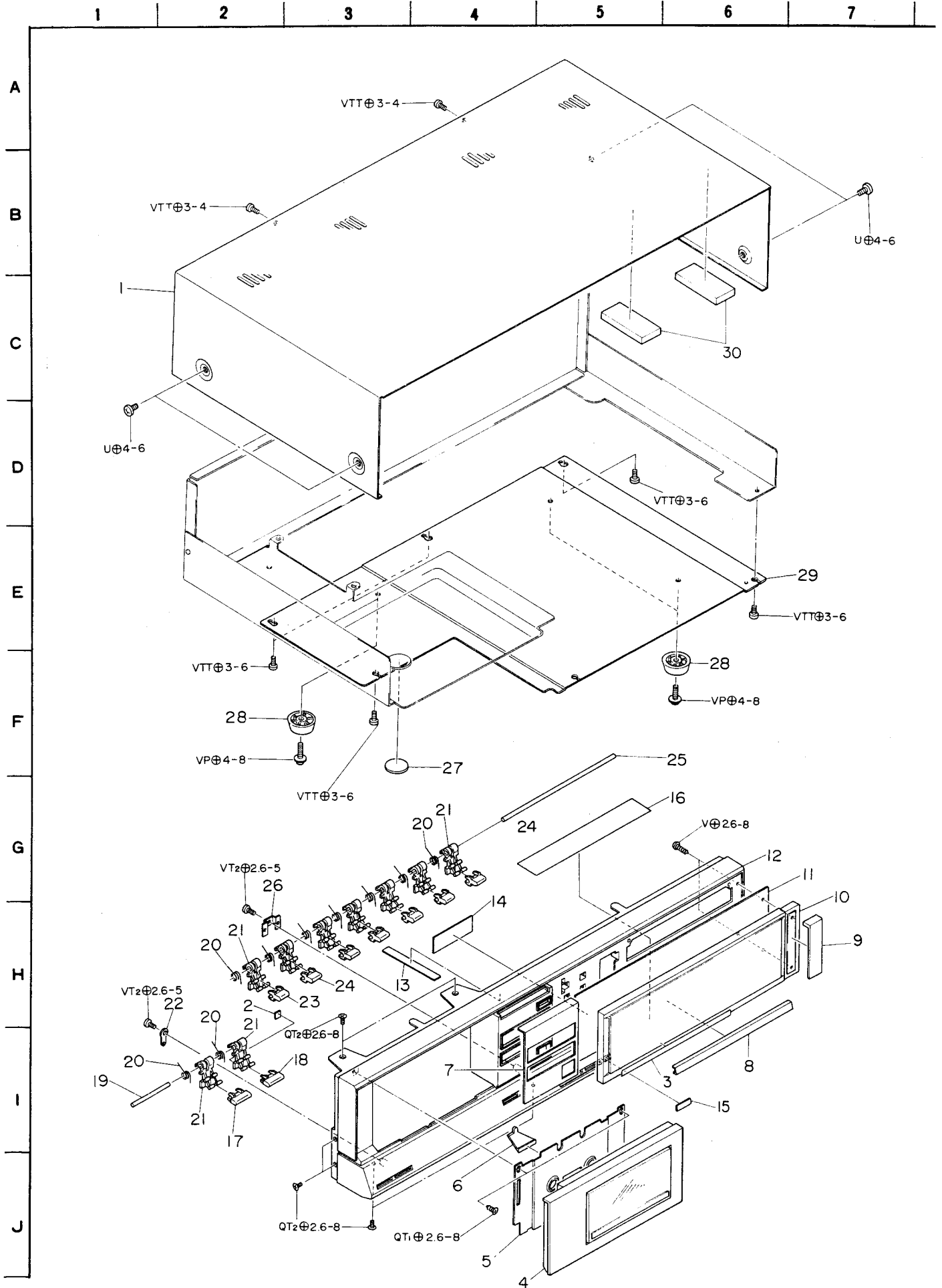

Fig. 5

EXPLODED VIEW-1



PARTS LIST

MECHANICAL PARTS

■ *mark in this part list shows exclusive part.

Ref. No	Part No.	Part No. Changed to	Description	Common Model	Q'ty
1-1	82-179-002-01		Cabinet, Steel	AD-3800	1
1-2	82-179-259-01		Sheet	AD-3800	1
1-3	82-182-032-01		Sheet, Bias instruction	*	1
1-4	82-182-034-01		Cover C box ass'y	*	1
1-5	82-180-009-01		Cassette plate	SD-L80	1
1-6	82-154-015-01		Guide, Light	AD-M700	1
1-7	82-182-029-01		Panel, Control	*	1
1-8	82-179-028-01		Name plate, REC	AD-3800	1
1-9	82-182-017-01		Plate, Meter window	*	1
1-10	82-182-031-11		Meter window ass'y	*	1
1-11	82-182-014-11		Display plate	*	1
1-12	82-182-001-11		Cabinet, Front	*	1
1-13	82-179-246-01		Sheet B, Earth	AD-3800	1
1-14	82-179-044-01		Counter plate	AD-3800	1
1-15	82-182-019-01		Cap, Push-button	*	1
1-16	82-179-045-01		Plate, Cabinet	AD-3800	1
1-17	82-179-011-01		Push-button, POWER	AD-3800	1
1-18	82-179-012-01		Push-button, EJECT	AD-3800	1
1-19	82-179-212-01		Shaft, Guide lever	AD-3800	1
1-20	82-179-234-11		T-spring, Guide lever	AD-3800	9
1-21	82-179-205-01		Guide lever, Push-button	AD-3800	9
1-22	82-179-236-01		Shaft B, Metal fitting	AD-3800	1
1-23	82-179-013-11		Push-button, ADMS	AD-3800	1
1-24	82-179-014-11		Push-button, SELECT	AD-3800	6
1-25	82-179-211-11		Shaft, Guide lever A	AD-3800	1
1-26	82-179-241-01		Shaft A, Metal fitting	AD-3800	1
1-27	82-168-025-01		Rubber foot	AD-3600	1
1-28	87-085-161-01		Foot		3
1-29	82-168-018-11		Cabinet, Bottom	AD-3600	1
1-30	82-179-243-11		Cushion, 20-50	AD-3800	2

EXPLODED VIEW-2

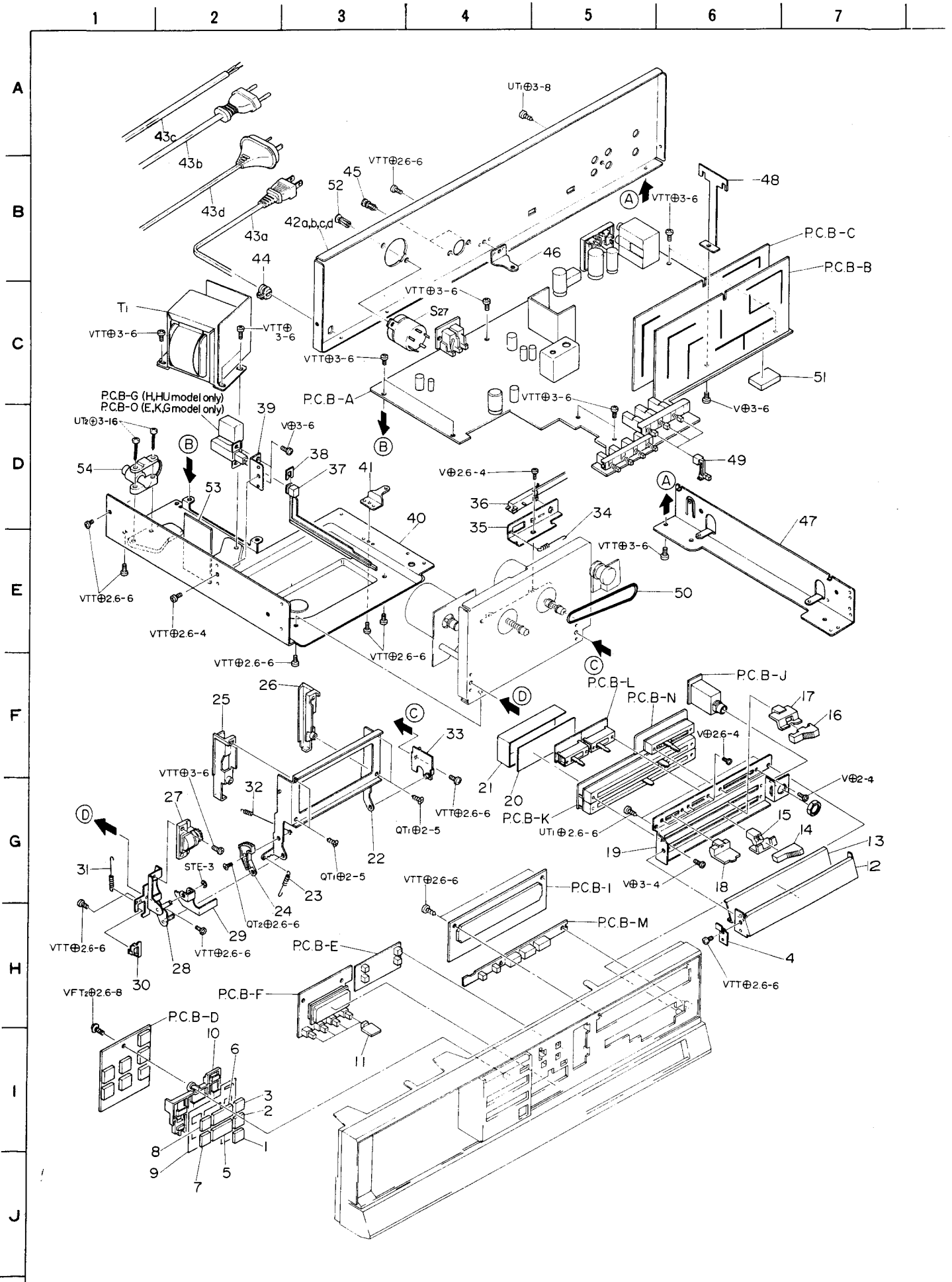

Ref. No	Part No.	Part No. Changed to	Description	Common Model	Q'ty
2-1	82-182-012-01		Touch-key, MUTE	*	1
2-2	82-182-011-01		Touch-key, PAUSE	*	1
2-3	82-182-008-01		Touch-key, FF	*	1
2-4	82-179-265-01		Shaft A, Holder	AD-3800	1
2-5	82-182-007-01		Touch-key, STOP	*	1
2-6	82-182-006-01		Touch-key, PLAY	*	1
2-7	82-182-010-01		Touch-key, REC	*	1
2-8	82-182-009-01		Touch-key, REW	*	1
2-9	82-179-242-11		Back sheet, LED	AD-3800	1
2-10	82-179-007-11		Light guide touch-key	AD-3800	1
2-11	82-182-004-01		Knob, Counter	*	4
2-12	82-179-027-21		Plate, REC knob	AD-3800	1
2-13	82-179-240-01		Auxiliary plate	AD-3800	1
2-14	82-179-017-01		REC knob R	AD-3800	1
2-15	82-179-219-01		REC lever R	AD-3800	1
2-16	82-179-016-01		REC knob L	AD-3800	1
2-17	82-179-218-11		REC knob L	AD-3800	1
2-18	82-179-015-31		Slide knob	AD-3800	3
2-19	82-179-203-11		Holder, VOLUME	AD-3800	1
2-20	82-179-248-01		Cushion, VOLUME	AD-3800	1
2-21	82-179-245-01		Sheet A, Earth	AD-3800	1
2-22	82-179-224-21		Cassette box ass'y	AD-3800	1
2-23	82-179-244-21		E-spring, Cassette lid	AD-3800	1
2-24	82-179-220-11		Gear, Oil damp	AD-3800	1
2-25	82-179-032-11		Cassette holder L	AD-3800	1
2-26	82-179-033-11		Cassette holder R	AD-3800	1
2-27	82-179-228-01		Oil damp	AD-3800	1
2-28	82-179-207-01		Cassette box holder L ass'y	AD-3800	1
2-29	82-179-204-01		Lever, Eject	AD-3800	1
2-30	82-179-233-01		Guide, Rod	AD-3800	1
2-31	82-179-227-01		E-spring, Slide plate	AD-3800	1
2-32	82-179-249-11		E-spring, Cassette box	AD-3800	1
2-33	82-161-312-01		Cassette box holder R ass'y		1
2-34	82-179-239-11		E-spring, Remote switch	AD-3800	1
2-35	82-179-238-11		Holder, Remote switch	AD-3800	1
2-36	82-179-635-11		Wire 280, Remote switch	AD-3800	1
2-37	82-304-211-11		Rod, Selector		1
2-38	82-385-383-11		Rod stopper	AD-6300	1
2-39	82-160-207-01		Holder, POWER	AD-M450	1
2-40	82-182-202-21		Amp. chassis L	*	1
2-41	82-179-210-01		Holder, Circuit board B	AD-3800	1
2-42 a	82-182-020-01		Panel, Rear (H, HU model only)	*	1
2-42 b	82-182-022-01		Panel, Rear (E model only)	*	1
2-42 c	82-182-023-01		Panel, Rear (K model only)	*	1
2-42 d	82-182-025-01		Panel, Rear (G model only)	*	1
2-43 a	87-034-826-01		AC power cord (H, HU model only)		1
2-43 b	87-034-877-01		AC power cord (E model only)		1
2-43 c	87-034-872-01		AC power cord (K model only)		1
2-43 d	87-034-892-01		AC power cord (G model only)		1
2-44	87-085-165-01		Cord bushing (H, HU model only)		1
2-45	87-084-078-01		Nylon rivet, 3-4.5		2
2-46	82-168-213-01		Holder, Circuit board	AD-3600	1
2-47	82-179-202-01		Amp. Chassis R	AD-3800	1
2-48	82-179-237-01		Holder, Dolby circuit board	AD-3800	1
2-49	82-179-213-01		Rod, Push-switch	AD-3800	3
2-50	82-179-256-01		Belt A, Counter	AD-3800	1
2-51	82-165-203-01		G cushion, PCB	SD-L10	1
2-52	87-085-090-01		Nylon rivet (H, HU model only)		2
2-53	82-773-215-01		Insulation sheet (E, K, G model only)	AT-9500	1
2-54	87-085-166-01		Holder, AC power cord (E, K G model only)		1

EXPLODED VIEW-3

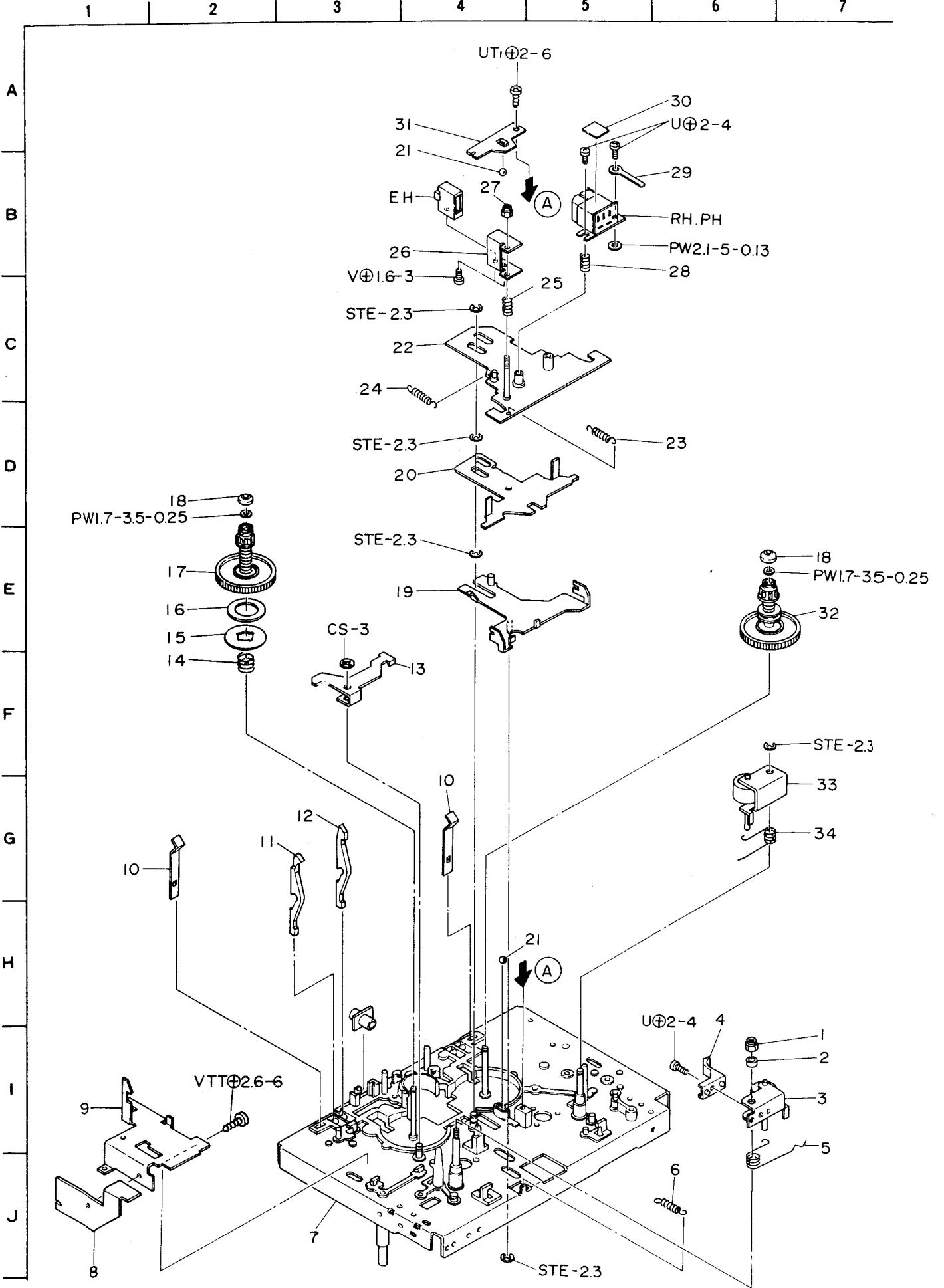

Ref No.	Part No.	Part No. Changed to	Description	Common Model	Q'ty
3-1	87-081-969-01		Nylon nut, M3-4.5		1
3-2	82-170-215-01		Collar, Pinch roller		1
3-3	82-170-208-01		Pinch lever S ass'y		1
3-4	82-170-216-01		Guide, Tape		1
3-5	82-170-218-11		T-spring, Pinch S		1
3-6	83-170-227-01		E-spring, Actuating pressure D		1
3-7	82-170-243-41		Outsert shaft ass'y D		1
3-8	82-179-230-01		Slide lever		1
3-9	82-161-324-41		Slide plate, Lock		1
3-10	82-161-293-01		P-spring, Cassette pressure		2
3-11	82-565-327-21		REC blocking lever		1
3-12	82-161-358-01		Cassette lever		1
3-13	82-161-347-11		Lever, Eject blocking		1
3-14	82-170-225-11		C-spring, BT SD		1
3-15	82-161-290-01		Washer 5.5-19		1
3-16	82-161-351-01		Felt, 1-16-10		1
3-17	82-161-259-21		Supply reel platform ass'y		1
3-18	82-303-398-01		Cap, Take-up reel platform		2
3-19	82-170-231-11		Slide plate, Actuating ass'y 2		1
3-20	82-170-288-11		Slide plate, Pause 2		1
3-21	87-073-005-01		Steel ball 2φ		2
3-22	82-170-273-21		Actuating chassis ass'y 2		1
3-23	82-170-226-11		E-spring, Pinch return		1
3-24	82-161-308-01		E-spring, Acutating		1
3-25	82-565-360-01		C-spring, EH		1
3-26	82-170-283-01		Holder, EH B2		1
3-27	87-081-963-01		Nylon nut, M2-3.5		1
3-28	82-307-212-01		C-spring, EH		1
3-29	87-038-056-01		Wire binder 2.3		1
3-30	87-057-620-01		Label, Head		1
3-31	82-161-292-01		P-spring, Actuating		1
3-32	82-170-251-01		Take-up reel platform 2 ass'y		1
3-33	82-170-294-01		Pinch roller T ass'y		1
3-34	82-161-301-01		T-spring, Pinch F		1

CAUTION

Please refer to service manual for AD-3600 in regard to description of the MD-3 mechanism, caution on disassembling MD-3 mechanism, spring allocation position and adjustment method, which are in common with AD-3600.

EXPLODED VIEW-4

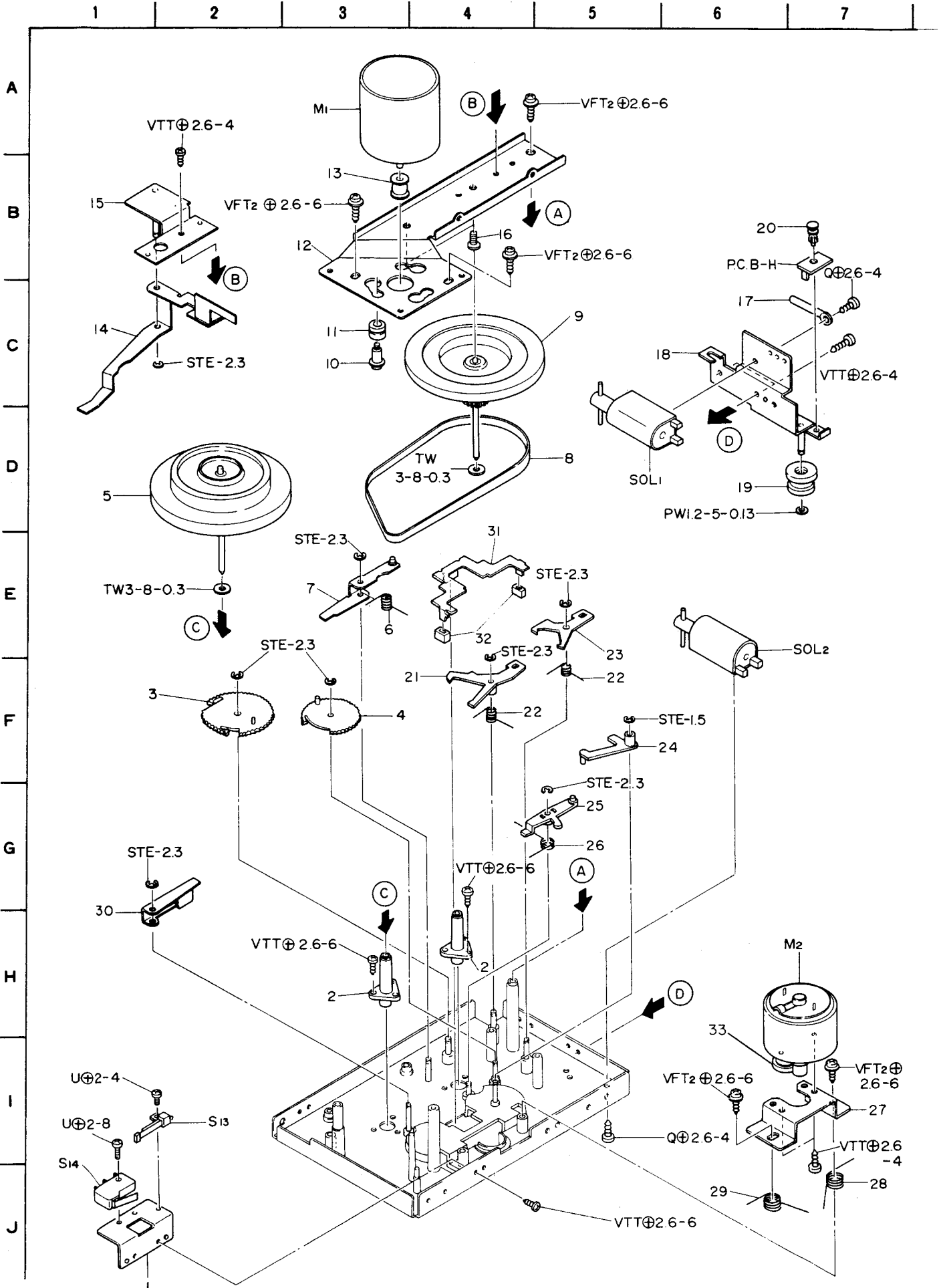

Ref. No.	Part No.	Part No. Changed to	Description	Common Model	Q'ty
4-1	82-161-234-01		Switch holder REC		1
4-2	82-161-253-01		Shaft bearing ass'y		2
4-3	82-161-276-11		Gear, PLAY		1
4-4	82-161-277-21		Gear, PAUSE		1
4-5	82-170-228-01		Flywheel S2 ass'y		1
4-6	82-161-300-01		T-spring, Play lever		1
4-7	82-161-218-01		Play lever ass'y		1
4-8	82-170-230-31		Rubber belt, Main		1
4-9	82-170-295-01		Flywheel T2 ass'y		1
4-10	87-081-483-01		Motor screw, M2.6		3
4-11	87-087-029-01		Rubber cushion		3
4-12	82-161-227-11		Flywheel plate		1
4-13	82-170-276-01		Motor pulley		1
4-14	82-170-236-01		Lever indicator ass'y		1
4-15	82-170-233-01		Holder indicator ass'y		1
4-16	82-331-107-21		Thrust screw		2
4-17	87-038-039-01		Wire binder		1
4-18	82-179-214-01		Holder pulley ass'y	AD-3800	1
4-19	87-050-150-01		Counter pulley ass'y		1
4-20	87-084-086-01		Nylon rivet 3.5—4.5		1
4-21	82-161-269-01		Trigger lever, PLAY		1
4-22	82-170-272-01		T-spring, Trigger		2
4-23	82-161-270-01		Trigger lever, PAUSE		1
4-24	82-161-272-01		Lever, Brake eject		1
4-25	82-161-266-11		FRP lever ass'y		1
4-26	82-161-298-11		T-spring, Pause lever		1
4-27	82-170-242-11		Holder, Motor		1
4-28	82-161-295-01		T-spring, Brake L		1
4-29	82-161-296-01		T-spring, Brake R		1
4-30	82-179-261-01		Lever, FRP-2	AD-3800	1
4-31	82-161-236-11		Slide plate, Brake		1
4-32	82-397-307-01		G cushion, Eject lever		2
4-33	82-170-248-01		Idler ass'y		1

ACCESSORIES/PACKAGE

Ref. No	Part No.	Part No. Changed to	Description	Common Model	Q'ty
1	82-182-852-01		Printed indiv., Packing	*	1
2	82-179-852-01		Cushion L, Printed indiv.	AD-3800	1
3	82-179-853-01		Cushion R, Printed indiv.	AD-3800	1
4	87-051-131-11		Poly-vinyl sack (H, HU model only)		1
5	87-051-135-11		Poly-vinyl sack (E, K, G model only)		1
6	87-056-607-01		Poly-vinyl sack		1
7	82-182-904-01		Instructions booklet		1
8	87-051-171-11		Poly-vinyl sack		1
9	87-056-008-11		Label, AC power cord (K model only)		1
10	87-056-009-51		Distributions list (H, E, K, G model only)		1
11	87-056-045-01		Guarantee card (HU model only)		1
12	87-056-050-01		Safety instruction (HU model only)		1
13	87-056-057-01		Service station list (HU model only)		1
14	87-056-059-01		Guarantee card (Gmodel only)		1
15	86-944-012-01		Connection cord CW-129BSK		2
16	87-032-845-01		Siemens plug (H, HU model only)		1

ELECTRICAL MAIN PARTS LIST

Table with columns: Symbol No., Part No., Description. Section: MAIN CIRCUIT BOARD SECTION. Includes parts like PCB-A, IC1, IC101, IC121, IC401, IC402, IC403, Q1,2, Q3,4,5,6, Q7,8,9,10, Q15,16,17, Q273,425, Q331,427, Q332,340,401, Q336,337, Q338, Q339, Q341, D1,402,404, D2,101,102, D331, D332, D333, D401, D409,410, L1,2,151, L152, L153,154, L155,156, L201, L202, LPF1, LPF151,152.

Table with columns: Symbol No., Part No., Description. Section: DOLBY-LCH CIRCUIT BOARD SECTION. Includes parts like X401, J1,2, J3,4,5,6, J7, S1,2,3,4, S5,6,7, S8,9, S10, SFR1,2,151,152, SFR3,4, SFR101,102,203, SFR153,154, SFR155,156, SFR201,202, CON2,4, CON1,3, R331, R502, R518, R347,474, R342, R342, R508, C413,414, C157,158, C415, C193,194, C273,274, C7,8, C1,2.

Table with columns: Symbol No., Part No., Description. Section: DOLBY-RCH CIRCUIT BOARD SECTION. Includes parts like R17,117, R11,41,111,141, C25,125, C39,139, C9, C3,7,31,35,103,107,131,135, C45,145, C23,123, PCB-C, IC2,102, Q2,4,6,8,10,102,104,106,108,110, Q12,112, D2,10,12,102,110,112, D4,6,8,14,16,18,20,22,104,106,108,114,116,118,120,122, SFR2,102, SFR4,104, PIN4, PIN2, R18,118, R12,42,112,142, C25,126, C40,140, C10, C4,8,32,36,104,108,132,136, C46,146, C24,124.

Table with columns: Symbol No., Part No., Description. Section: LED-1 CIRCUIT BOARD SECTION, COUNTER CIRCUIT BOARD SECTION, POWER SWITCH CIRCUIT BOARD SECTION, HALL IC CIRCUIT BOARD SECTION, METER CIRCUIT BOARD SECTION, JACK CIRCUIT BOARD SECTION, VOLUME CIRCUIT BOARD-1 SECTION. Includes parts like PCB-E, PCB-F, PCB-G, PCB-H, PCB-K, PCB-L, PCB-M, PCB-N, PCB-J.

Table with columns: Symbol No., Part No., Description. Section: SWITCH CIRCUIT BOARD SECTION, LED-2 CIRCUIT BOARD SECTION, VOLUME CIRCUIT BOARD SECTION, POWER SWITCH CIRCUIT BOARD SECTION, MISCELLANEOUS. Includes parts like PCB-L, PCB-M, PCB-N, PCB-O, T1, T1, T1, RH, PH, EH, M1, M2, S0L1,2, S13, S14, S27.

Safety components This symbol is given to the safety of the product safety specifications. This symbol, make absolu

Symbol No.	Part No.	Description
X401	87-008-236-01	Ceramic resonator
J1,2	82-168-634-01	Jack, 6,3φ (MIC L, R)
J3,4,5,6	87-049-055-01	Pin jack, 4P (LINE IN/REC, LINE OUT/PLAY)
J7	87-032-985-01	DIN socket 8P (REMOTE)
S1,2,3,4	82-179-620-01	Push-switch (ADMS, DOLBY-NR ON/OFF, B/C, MONITOR)
S5,6,7	82-182-615-01	Push switch ass'y (TAPE SELECTOR)
S8,9	87-031-650-01	Slide switch (MPX FILTER, PHONES LEVEL)
S10	82-179-628-01	Remote switch (REC/PB)
SFR1,2,151,152	87-021-569-01	Semi-fixed resistor, 50kΩ-B
SFR3,4	87-021-687-01	Semi-fixed resistor, 30kΩ-B
SFR101,102,203	87-021-688-01	Semi-fixed resistor, 2kΩ-B
SFR153,154	87-021-568-01	Semi-fixed resistor, 20kΩ-B
SFR155,156	87-021-567-01	Semi-fixed resistor, 10kΩ-B
SFR201,202	87-021-614-01	Semi-fixed resistor, 22kΩ-B
CON2,4	87-032-575-01	Connecotr, 5P
CON1,3	87-032-577-01	Connecotr, 7P
< Resistors >		
R331	87-029-066-01	1.5Ω 1/2W Fuse resistor (H, HU model only)
R331	87-029-088-01	1.5Ω 1/2W Fuse resistor (E, K, G model only)
R502	87-029-089-01	4.7Ω 1/4W Fuse resistor
R518	87-029-089-01	4.7Ω 1/4W Fuse resistor (E, K, G model only)
R347,474	87-029-117-01	10Ω 1/2W Fuse resistor
R342	87-029-094-01	15Ω 1/4W Fuse resistor (H, HU model only)
R342	87-029-382-01	15Ω 1/4W Fuse resistor (E, K, G model only)
R508	82-182-620-01	100Ω x 7 Resistor block
< Capacitors >		
C413,414	87-015-885-01	22μF 63V Electrolytic
C157,158	87-015-243-01	3.3μF 50V Electrolytic
C415	87-015-453-01	2.2μF 25V Electrolytic BP
C193,194	87-014-037-01	150pF PP
C273,274	87-014-118-01	0.015μF PP
C7,8	87-014-119-01	0.027μF PP
C1,2	88-238-450-81	150μF 500V YP
< DOLBY-LCH CIRCUIT BOARD SECTION >		
PCB-B	82-175-622-21	Dolby-Lch circuit board
IC1,101	87-027-738-01	IC, HA11226
Q1,3,5,7,9,101,103,015,107,109	89-318-154-51	Transistor, 2SC1815Y (GR)
Q11,111	89-109-922-01	Transistor, 2SA992
D1,9,11	88-052-188-11	Diode, 1S188 (FM)
101,109,111		
D3,5,7,13,15,17,19,21,103,105,107,113,115,117,119,121	87-027-097-01	Diode, 1S1555
SFR1,101	87-021-626-01	Semi-fixed resistor, 2kΩ-B
SFR3,103	87-021-634-01	Semi-fixed resistor, 10kΩ-B
PIN3	87-032-635-01	Pin, 5P
PIN1	87-032-637-01	Pin, 7P

Symbol No.	Part No.	Description
R17,117	87-025-271-01	5.1kΩ 1/4W ±1% Metal film
R11,41,111,141	87-025-272-01	13kΩ 1/4W ±1% Metal film
< Capacitors >		
C25,125	87-015-329-01	0.33μF 50V Electrolytic LL
C39,139	87-015-895-01	0.39μF 50V Electrolytic
C9	87-015-380-01	4.7μF 25V Electrolytic BP
C3,7,31	87-014-118-01	0.015μF ±2% PP
35,103,107,131,135		
C45,145	87-015-427-01	0.15μF 25V Aluminum solid
C23,123	87-015-429-01	0.33μF 25V Aluminum solid
< DOLBY-RCH CIRCUIT BOARD SECTION >		
PCB-C	92-175-622-21	Dolby-Rch circuit board
IC2,102	87-027-738-01	IC, HA11226
Q2,4,6,8,10,102,104,106,108,110,112	89-318-154-51	Transistor, 2SC1815Y (GR)
Q12,112	89-109-922-01	Transistor, 2SA992
D2,10,12,102,110,112	88-052-188-11	Diode, 1S188 (FM)
D4,6,8,14,16,18,20,22,104,106,108,114,116,118,120,122	87-027-097-01	Diode, 1S1555
SFR2,102	87-021-626-01	Semi-fixed resistor, 2kΩ-B
SFR4,104	87-021-634-01	Semi-fixed resistor, 10kΩ-B
PIN4	87-032-635-01	Pin, 5P
PIN2	87-032-637-01	Pin, 7P
< Resistors >		
R18,118	87-025-271-01	5.1kΩ 1/4W ±1% Metal film
R12,42,112,142	87-025-272-01	13kΩ 1/4W ±1% Metal film
< Capacitors >		
C25,126	87-015-329-01	0.33μF 50V Electrolytic LL
C40,140	87-015-895-01	0.39μF 50V Electrolytic
C10	87-015-380-01	4.7μF 25V Electrolytic BP
C4,8,32,36,104,108,132,136	87-014-118-01	0.015μF ±2% PP
C46,146	87-015-427-01	0.15μF 25V Aluminum solid
C24,124	87-015-429-01	0.33μF 25V Aluminum solid
< KEY BOARD SWITCH CIRCUIT BOARD SECTION >		
PCB-D	*	Key board switch circuit board (H, HU model only)
PCB-D	*	Key board switch circuit board (E, K, G model only)
Q601	89-109-521-01	Transistor, 2SA952K
D601	88-052-188-11	Diode, 1S188 (FM)
D602,605	87-027-809-01	LED, SLP-153BR (REC MUTE)
D603	87-027-790-01	LED, SLP-253B (G) (PLAY)
D604	87-027-810-01	LED, SLP-453B (Q) (PAUSE)
S15,16,17,18,19,20,21	87-031-654-01	Tact switch (REC, REW/REV, PLAY, FF/CUE, STOP, PAUSE, MUTE)

Symbol No.	Part No.	Description
< LED-1 CIRCUIT BOARD SECTION >		
PCB-E	*	LED-1 circuit board (H, HU model only)
PCB-E	*	LED-1 circuit board (E, K, G model only)
D1	87-027-773-01	LED, GL-9NG4
D2,4	87-027-772-01	LED, GL-9PR4
D3	87-027-774-01	LED, GL-9HY4
< COUNTER CIRCUIT BOARD SECTION >		
PCB-F	*	Counter circuit board (H, HU model only)
PCB-F	*	Counter circuit board (E, K, G model only)
FL601	82-182-616-11	Fluorescent lamp
D608,609	88-052-188-11	Diode, 1S188 (FM)
S22,23,24,	87-031-670-01	Tact switch, E VQ-Q8B11K (RESET, TAPE TIME, COUNTER, MEMORY REWIND)
< POWER SWITCH CIRCUIT BOARD SECTION >		
PCB-G	*	Power switch circuit board (H, HU model only)
S26	87-031-638-01	Push-switch (POWER)
< Capacitor >		
C343	87-019-112-01	0.01μF Spark killer
< HALL IC CIRCUIT BOARD SECTION >		
PCB-H	*	Hall IC circuit board (H, HU model only)
PCB-H	*	Hall IC circuit board (E, K, G model only)
IC700	87-027-505-01	Hall IC, DN-6838
< METER CIRCUIT BOARD SECTION >		
	82-187-619-01	LED display module ass'y (With PCB-I)
IC1	87-027-725-01	IC, MSL9350RS
Q1,2,3,4	82-179-708-01	Transistor, 2SD598 (E)
(Q1,2,3,4)	89-109-521-01	Transistor, 2SA952 (K)
Q5	89-318-154-51	Transistor, 2SC1815 (Y)
Q6	82-179-673-01	Transistor, N13T-1
< Resistor >		
R12-1,12-2,12-3,12-4,12-5,12-6,12-7,12-8	82-179-709-01	560Ω x 8 Resistor block
< JACK CIRCUIT BOARD SECTION >		
PCB-J	*	Jack circuit board (H, HU model only)
PCB-J	*	Jack circuit board (E, K, G model only)
J8	82-168-633-01	Jack, 6,3φ (PHONES)
< VOLUME CIRCUIT BOARD-1 SECTION >		
PCB-K	*	Volume circuit board-1 (H, HU model only)
PCB-K	*	Volume circuit board-1 (E, K, G model only)
VR2	82-179-617-01	Slide volume, 30kΩ (RECORD LEVEL)

Symbol No.	Part No.	Description
< SWITCH CIRCUIT BOARD SECTION >		
PCB-L	*	Switch circuit board (H, HU model only)
PCB-L	*	Switch circuit board (E, K, G model only)
D606,607	88-052-188-11	Diode, 1S188 (FM)
S11,12	82-160-628-01	Slide switch (TIMER, COUNTER)
< LED-2 CIRCUIT BOARD SECTION >		
PCB-M	*	LED-2 circuit board (H, HU model only)
PCB-M	*	LED-2 circuit board (E, K, G model only)
D303	87-027-775-01	LED, LT9030DI
D304	87-027-776-01	LED, LT9030N
D305	87-027-777-01	LED, LT9030H
D306,307	87-027-774-01	LED, GL-9HY4
< VOLUME CIRCUIT BOARD-2 SECTION >		
PCB-N	*	Volume circuit board-2 (H, HU model only)
PCB-N	*	Volume circuit board-2 (E, K, G model only)
VR1	82-182-635-01	Slide volume, 10kΩ-C (LH BIAS FINE)
< POWER SWITCH CIRCUIT BOARD SECTION > = E, K, G model only		
PCB-O	82-179-696-01	Power switch circuit board
S26	87-031-640-01	Push-switch (POWER)
< Capacitor >		
C1	87-019-112-01	0.01μF Spark killer
< MISCELLANEOUS >		
T1	82-179-615-01	Power transformer (H, HU model only)
T1	82-179-697-01	Power transformer (E model only)
T1	82-179-614-11	Power transformer (K, G model only)
RH, PH	87-046-194-01	Combination head
EH	87-046-192-01	Erase head
M1	87-045-175-01	Motor DC system servo
M2	87-045-164-11	DC motor, Reel B
SOL1,2	82-179-630-01	Solenoid DM-6
PL1	82-180-661-01	Lamp ass'y
S13	82-283-631-01	Leaf switch (CASSETTE)
S14	87-031-610-01	Micro switch (SS-01GL, F (RECORD))
S27	87-031-586-01	Slide switch (VOLTAGE SELECTOR) (H, HU model only)
	87-033-140-01	Splice connector (H, HU model only)
	87-085-166-01	Holder, AC power cord (E, K, G model only)
	87-034-826-01	AC power cord (H, HU model only)
	87-034-877-01	AC power cord (E model only)
	87-034-872-01	AC power cord (K model only)
	87-034-892-01	AC power cord (G model only)
	87-085-165-01	Cord bushing (H, HU model only)

 Safety component symbol
This symbol is given to important parts which serve to maintain the safety of the product, and which are made to conform to special safety specifications. Therefore, when replacing a component with this symbol, make absolutely sure that you use a designated part.

SCHEMATIC DIAGRAM-1

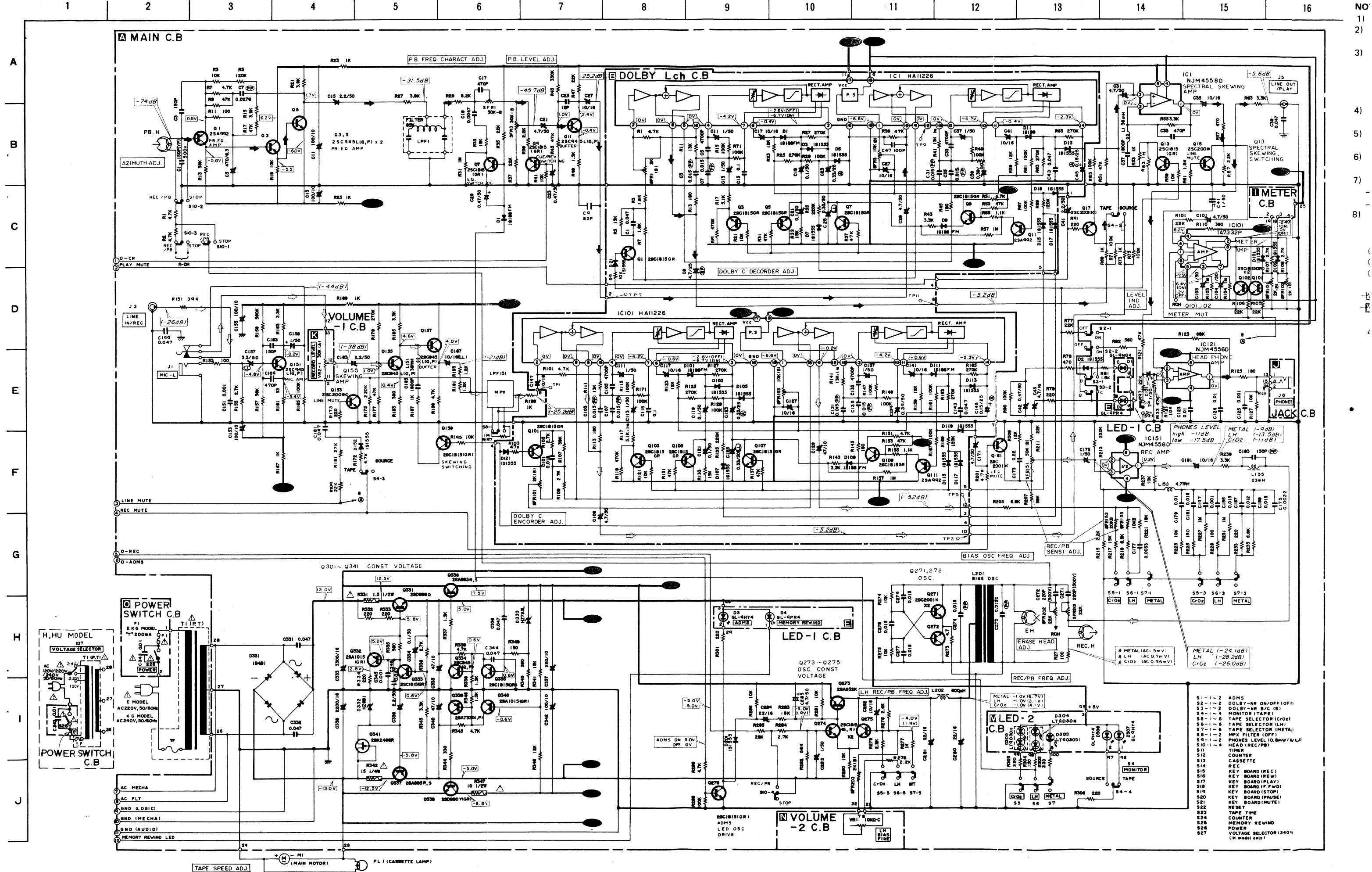

- S1-1-2 ADMS
- S2-1-2 DOLBY-NR ON/OFF(LO)
- S3-1-2 DOLBY-BR B/C (B)
- S4-1-4 TAPE SELECTOR (TAPE)
- S5-1-6 TAPE SELECTOR (CR2)
- S6-1-2 TAPE SELECTOR (LH)
- S7-1-6 TAPE SELECTOR (METAL)
- S8-1-2 MPX FILTER (OFF)
- S9-1-2 PHONES LEVEL (0.8mV/0V)
- S10-1-4 HEAD (REC/PB)
- S11 TIMER
- S12 COUNTER
- S13 CASSETTE
- S14 REC
- S15 KEY BOARD (REC)
- S16 KEY BOARD (REW)
- S17 KEY BOARD (PLAY)
- S18 KEY BOARD (F.FWD)
- S19 KEY BOARD (STOP)
- S20 KEY BOARD (PAUSE)
- S21 KEY BOARD (MUTE)
- S22 RESET
- S23 TAPE TIME COUNTER
- S24 MEMORY REWIND
- S25 POWER
- S26 VOLTAGE SELECTOR (240V) (H model only)
- S27

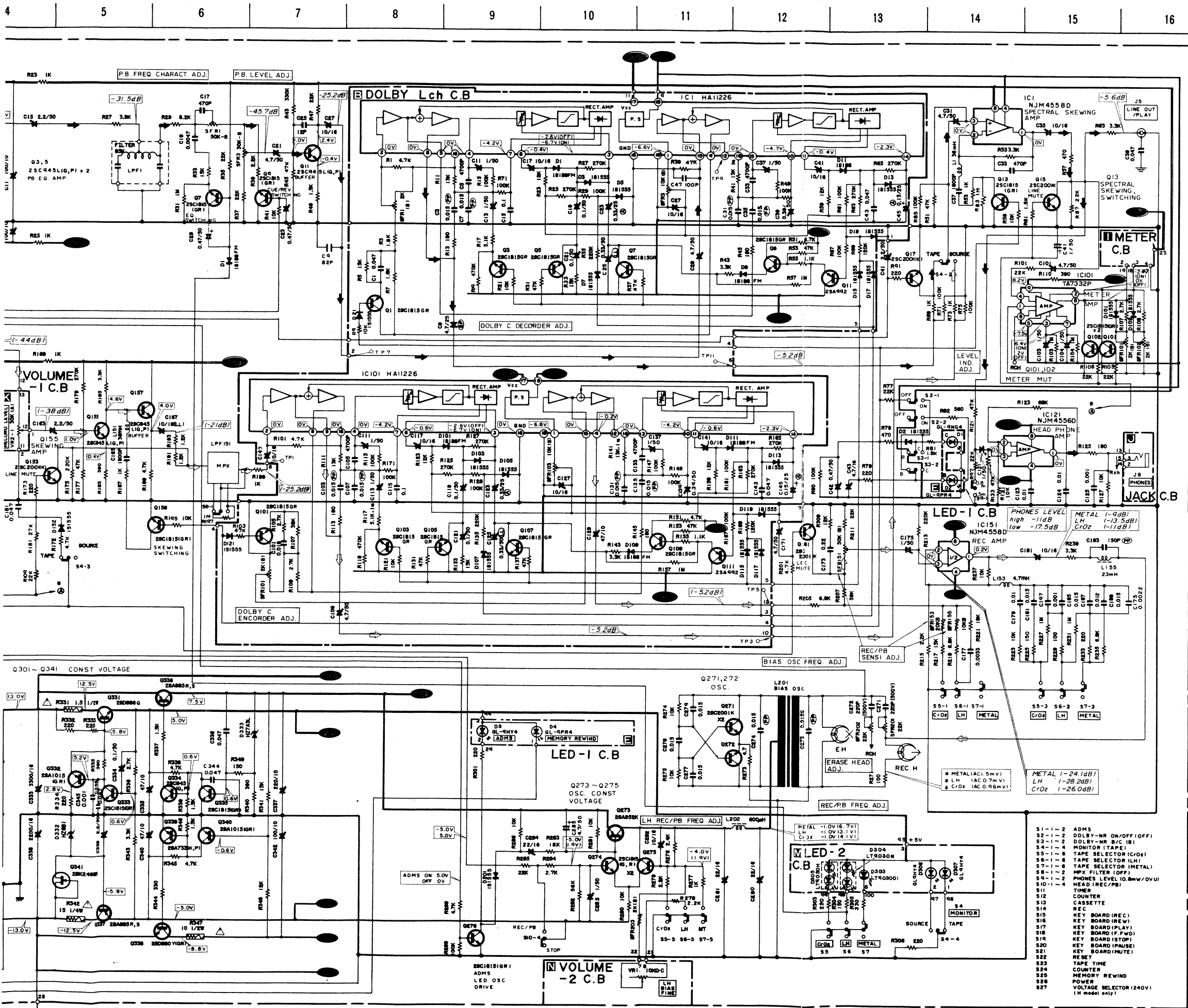

- NOTES:**
- 1) B (+), power supply B (-), power supply
 - 2) Signal path
 Rec path,
 - 3) The voltage is the reference value measured with a tester (20 k-ohms/V DC) when there are no signals. But () is with recording. An asterisk (*) indicates that the value was measured with a vacuum-tube voltmeter during recording.
 - 4) Resistors with no designation have a rated power of 1/4W and a tolerance of ±5%.
 - 5) Capacitors with no designation have a dielectric strength of less than 50WV.
 - 6) The only capacitor tolerance indicated are ±5% (J) and ±10% (K).
 - 7) Ceramic capacitor symbols:
 High dielectric constant system (YY)
 High dielectric constant system (YW, YP, YZ)
 - 8) Explanation of symbols
 Mylar capacitor
 Aluminum solid capacitor
 Polypropylene film capacitor
 Bi-polarized capacitor
 Low-leakage capacitor
 Tantalum capacitor
 Fuse resistor
 Nonflammable resistor
- Safety component symbol
 This symbol is given to important parts which serve to maintain the safety of the product, and which are made to conform to special safety specifications. Therefore, when replacing a component with this symbol, make absolutely sure that you use a designated part.
- This schematic diagram is subject to change without notice in the interests of improved performance.

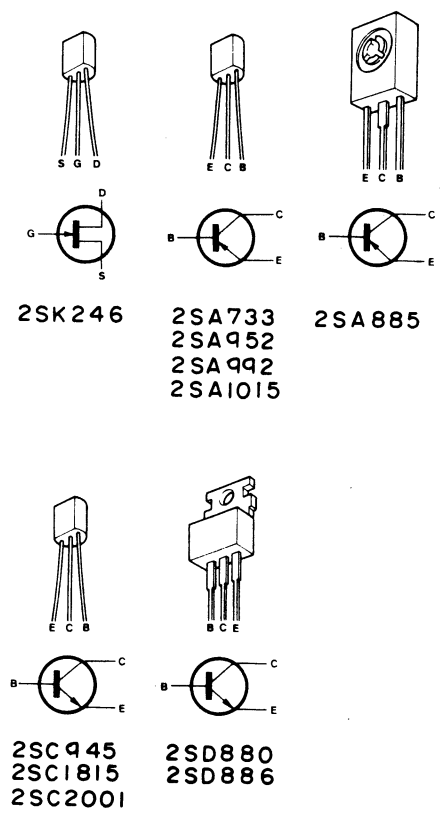

- S1-1-2 ADMS
- S2-1-2 DOLBY-MR ON/OFF (OFF)
- S3-1-2 DOLBY-MR B/C (B)
- S4-1-2 MONITOR (TAPE)
- S5-1-6 TAPE SELECTOR (CrO2)
- S6-1-6 TAPE SELECTOR (LH)
- S7-1-6 TAPE SELECTOR (METAL)
- S8-1-2 HPX FILTER (OFF)
- S9-1-2 PHONES LEVEL (0.8mW/0V)
- S10-1-4 HEAD (REC/PB)
- S11 TIMER
- S12 COUNTER
- S13 CASSETTE
- S14 REC
- S15 KEY BOARD (REC)
- S16 KEY BOARD (REW)
- S17 KEY BOARD (PLAY)
- S18 KEY BOARD (F.FWD)
- S14 KEY BOARD (STOP)
- S20 KEY BOARD (PAUSE)
- S21 KEY BOARD (MUTE)
- S22 RESET
- S23 TAPE TIME
- S24 COUNTER
- S25 MEMORY REWIND
- S26 POWER
- S27 VOLTAGE SELECTOR (240V) (LH model only)

Circuit description

Explanation of operation

1. Outline

The AD-3700 system controller is composed of a closed loop dual capstan mechanism drive circuit, and a FL (Fluorescent Lamp) electronic counter drive circuit using a 4-bit μ -computer.

2. Block diagram of controller and peripheral circuits

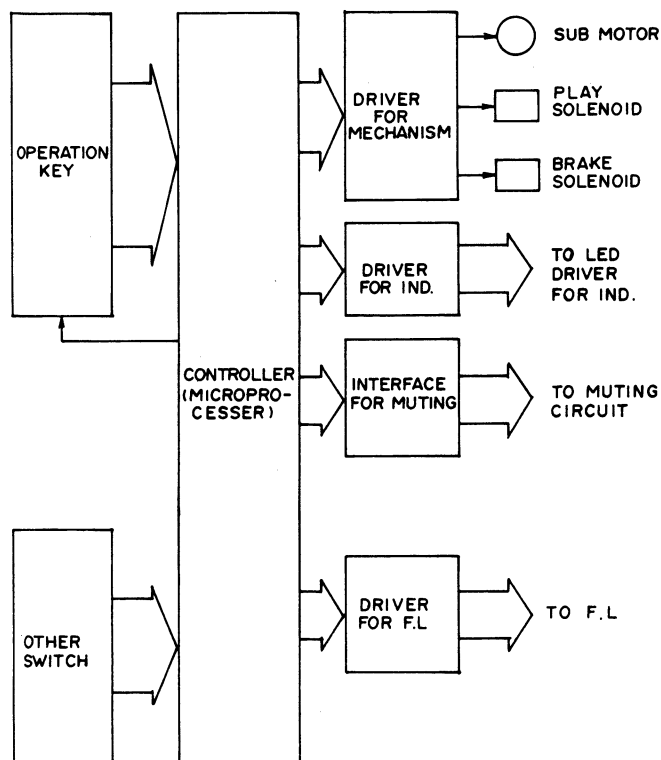

Fig-1

3. Controller specifications

3-1. General specifications

3-1-1. It is the same as a concretion controller for STOP, PLAY, RWD, FF, REC, REC/PLAY, PLAY-PAUSE and REC/PLAY-PAUSE.

3-1-2. CUE-REV: Possible by double-pressing the PLAY and FF (or RWD) keys.

3-1-3. ONE-REC: Enters REC/PLAY-PAUSE mode only when REC key is pressed in the PAUSE mode.

3-1-4. TIMER-REC/PLAY: Same as in general specifications.

3-1-5. TIMER-PLAY: Same as in general specifications.

3-1-6. AUTO-REPEAT: Same as in general specifications.

3-1-7. MEMORY-STOP: Same as in general specifications.

3-1-8. MEMORY-PLAY: Same as in general specifications.

3-2. Additional functions

3-2-1. REC-MUT-TIMER (1): Automatically enters the REC/PLAY-PAUSE mode 4 seconds after the REC-MUT key is pressed for MS (music sensor) and released.

3-2-2. REC-MUT-TIMER (2): When this key is pressed continuously to leave a non-recorded section of 4 sec or more, the LED winds every 2 seconds after 4 seconds.

3-2-3. Tape slack prevention: When the cassette is loaded, RED (120ms) - FF (120ms) operation is done to prevent the tape from becoming slack.

3-2-4. ADMS: This is the device to demagnetize the head.

3-3. Controller timing

Control timing of the mechanism and muting timing are taken into consideration, so a peripheral time constant circuit is not required.

4. Terminal connection diagram

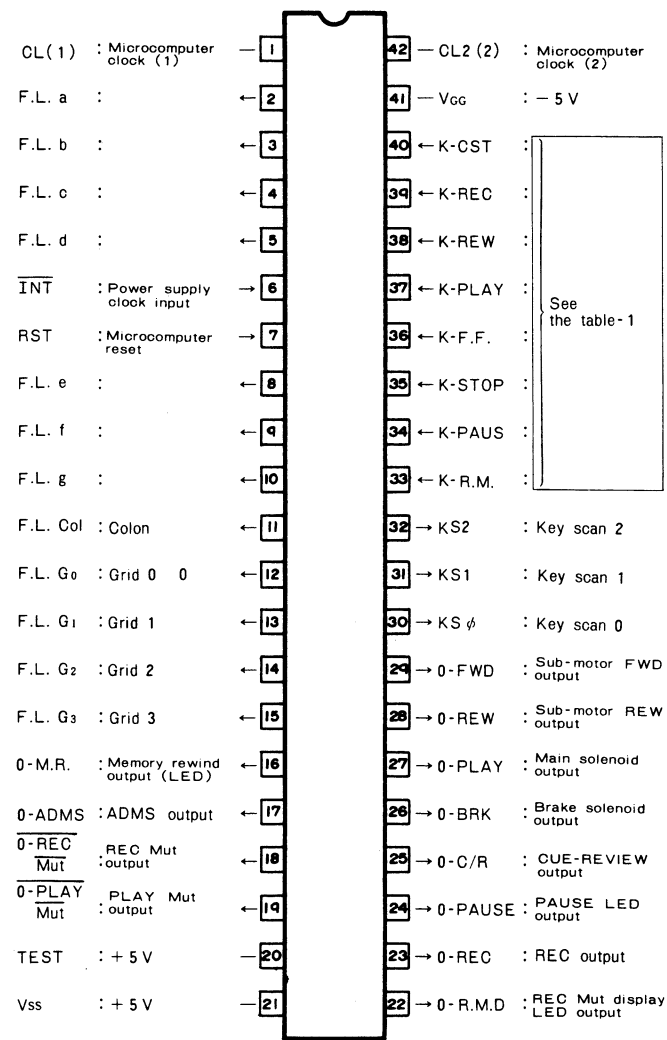

F.L.: (Fluorescent Lamp)
Arrows at terminals show the direction of signal flow.

Fig-2

1st (KSφ)	2nd (KS 1)	3rd (KS 2)
Cassette decoration Switch		Hall IC
REC KEY	Timer Rec Switch	Counter reset Switch
REW KEY	Timer PLAY Switch	Watch Switch
PLAY KEY	Counter repeat Switch	Counter Switch
F.F. KEY	Counter STOP Switch	
STOP KEY	REC prohibit Switch	
PAUSE KEY		Memory Switch
REC MUT KEY	ADMS Switch	

Table-1

5. Description of terminals (μ PD 546-286)

Terminal No.	Terminal symbol	Item
1, 42	CL(1), CL(2)	μ PD546. Clock oscillation terminal (400 kHz)
2	a	Control terminal for segment a of F.L. plate
3	b	Control terminal for segment b of F.L. plate
4	c	Control terminal for segment c of F.L. plate
5	d	Control terminal for segment d of F.L. plate
6	INT	Input terminal to measure "Watch" time of the digital counter out of power supply frequency clock.
7	RST	Input terminal for microcomputer reset when switching power ON or OFF.
8	e	Control terminal for segment e of F.L. plate
9	f	Control terminal for segment f of F.L. plate
10	g	Control terminal for segment g of F.L. plate
11	Col	Control terminal for colon of F.L. plate
12	G ₀	Control terminal for grid G ₀ of F.L.
13	G ₁	Control terminal for grid G ₁ of F.L.
14	G ₂	Control terminal for grid G ₂ of F.L.
15	G ₃	Control terminal for grid G ₃ of F.L.
16	0-M.R.	The bit is set to "1" during Memory ON
17	0-ADMS	The bit is set to "1" during ADMS ON
18	0-REC MUT	Output terminal for REC MUTING to be set to ON when "0"
19	0-PLAY MUT	Output terminal for PLAY MUTING to be set to ON when "0"

20, 21	Vss	+5V terminal (power source terminal)
22	0-R.M.D.	Output terminal to be set to play of condition of REC MUTE operation
23	0-REC	Output terminal to be set "1" during REC operation
24	0-PAUSE	Output terminal to indicate PAUSE operation
25	0-CUE/REV	Output terminal to be set to "1" during CUE/REV operation. Controls sub-motor torque, MUTING and so on.
26	0-BRK	Output terminal for brake solenoid
27	0-PLAY	Output terminal for main solenoid
28	0-REW	Output terminal to control revolution direction (reverse revolution) of sub-motor
29	0-FWD	Output terminal to control revolution direction (normal revolution) of sub-motor
30	KSφ	Scan output terminal for 8 key inputs of mechanism control
31	KS1	Scan output terminal for 6 key inputs such as Timer switch, Repeat switch, REC prohibit switch, ADMS and so on.
32	KS2	Scan output terminal for 5 key inputs such as Counter switch, Hall IC/ autostop detection and so on.
33~40	K.R.M.~K-CST	Data input terminals for matrix key inputs. Refer to the Table-1 in the details of data. Meanwhile, each operation is performed under the conditions of Table-3.
41	VGG	-5V terminal (power source terminal)

Table-2

KEY Mode	KSφ	KS 1	KS 2
1st (Mechanism control)	"H" to "L" level	"L" level	"L" level
2nd (Timer and etc.)	"L" level	"H" level	"L" level
3rd (Counter and etc.)	"L" level	"L" level	"H" level

"H" level > 3V
"L" level < 0.7V

Table-3

3-2. Additional functions

3-2-1. REC-MUT-TIMER (1): Automatically enters the REC/PLAY-PAUSE mode 4 seconds after the REC-MUT key is pressed for MS (music sensor) and released.

3-2-2. REC-MUT-TIMER (2): When this key is pressed continuously to leave a non-recorded section of 4 sec or more, the LED winds every 2 seconds after 4 seconds.

3-2-3. Tape slack prevention: When the cassette is loaded, RED (120ms) - FF (120ms) operation is done to prevent the tape from becoming slack.

3-2-4. ADMS: This is the device to demagnetize the head.

3-3. Controller timing

Control timing of the mechanism and muting timing are taken into consideration, so a peripheral time constant circuit is not required.

4. Terminal connection diagram

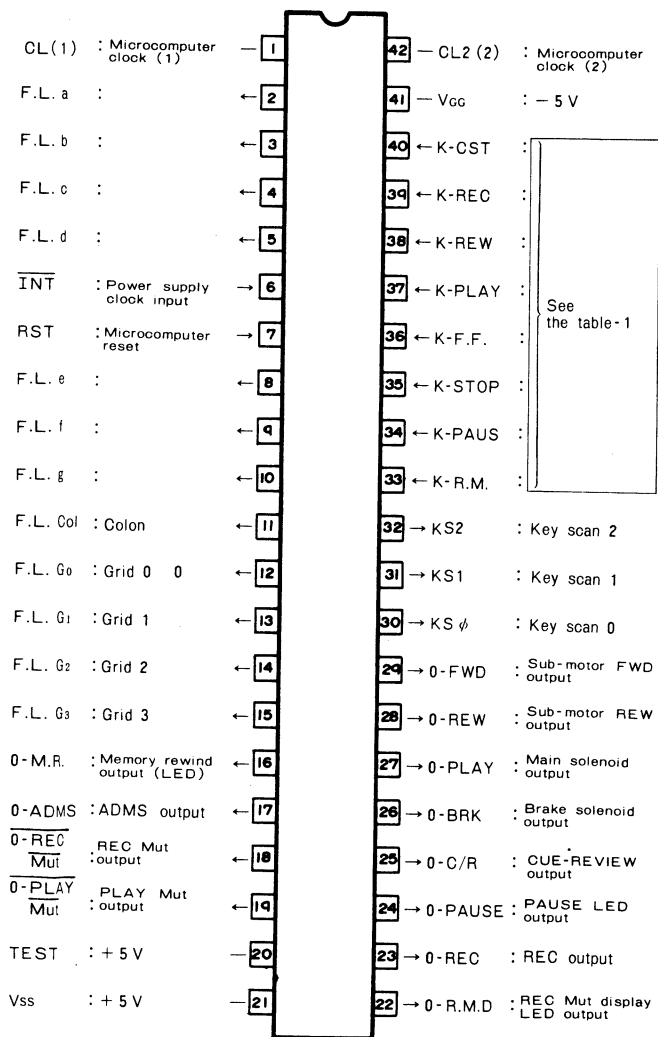

F.L.: (Fluorescent Lamp)
Arrows at terminals show the direction of signal flow.

1st (KSφ)	2nd (KS 1)	3rd (KS 2)
Cassette decoration Switch		Hall IC
REC KEY	Timer Rec Switch	Counter reset Switch
REW KEY	Timer PLAY Switch	Watch Switch
PLAY KEY	Counter repeat Switch	Counter Switch
F.F. KEY	Counter STOP Switch	
STOP KEY	REC prohibit Switch	
PAUSE KEY		Memory Switch
REC MUT KEY	ADMS Switch	

Table-1

5. Description of terminals (μPD 546-286)

Terminal No.	Terminal symbol	Item
1, 42	CL(1), CL(2)	μPD546. Clock oscillation terminal (400 kHz)
2	a	Control terminal for segment a of F.L. plate
3	b	Control terminal for segment b of F.L. plate
4	c	Control terminal for segment c of F.L. plate
5	d	Control terminal for segment d of F.L. plate
6	INT	Input terminal to measure "Watch" time of the digital counter out of power supply frequency clock.
7	RST	Input terminal for microcomputer reset when switching power ON or OFF.
8	e	Control terminal for segment e of F.L. plate
9	f	Control terminal for segment f of F.L. plate
10	g	Control terminal for segment g of F.L. plate
11	Col	Control terminal for colon of F.L. plate
12	G ₀	Control terminal for grid G ₀ of F.L.
13	G ₁	Control terminal for grid G ₁ of F.L.
14	G ₂	Control terminal for grid G ₂ of F.L.
15	G ₃	Control terminal for grid G ₃ of F.L.
16	0-M.R.	The bit is set to "1" during Memory ON
17	0-ADMS	The bit is set to "1" during ADMS ON
18	0-REC MUT	Output terminal for REC MUTING to be set to ON when "0"
19	0-PLAY MUT	Output terminal for PLAY MUTING to be set to ON when "0"

20, 21	Vss	+5V terminal (power source terminal)
22	0-R.M.D.	Output terminal to be set to play of condition of REC MUTE operation
23	0-REC	Output terminal to be set "1" during REC operation
24	0-PAUSE	Output terminal to indicate PAUSE operation
25	0-CUE/REV	Output terminal to be set to "1" during CUE/REV operation. Controls sub-motor torque, MUTING and so on.
26	0-BRK	Output terminal for brake solenoid
27	0-PLAY	Output terminal for main solenoid
28	0-REW	Output terminal to control revolution direction (reverse revolution) of sub-motor
29	0-FWD	Output terminal to control revolution direction (normal revolution) of sub-motor
30	KSφ	Scan output terminal for 8 key inputs of mechanism control
31	KS1	Scan output terminal for 6 key inputs such as Timer switch, Repeat switch, REC prohibit switch, ADMS and so on.
32	KS2	Scan output terminal for 5 key inputs such as Counter switch, Hall IC/ autostop detection and so on.
33~40	K.R.M.~K-CST	Data input terminals for matrix key inputs. Refer to the Table-1 in the details of data. Meanwhile, each operation is performed under the conditions of Table-3.
41	VGG	-5V terminal (power source terminal)

Table-2

KEY Mode	KSφ	KS 1	KS 2
1st (Mechanism control)	"H" to "L" level	"L" level	"L" level
2nd (Timer and etc.)	"L" level	"H" level	"L" level
3rd (Counter and etc.)	"L" level	"L" level	"H" level

"H" level > 3V
"L" level < 0.7V

Table-3

Circuit explanation

6. System controller

6-1. MPU (Microprocessor Unit)

This is a 4-bit MPU which is the heart of the control unit. It works in the following sequence when power is applied.

Step 1:

Simultaneously with the power supply, the internal clock oscillator with a frequency of 400 Hz determined by the ceramic filter connected between CL1 (pin 1) and CL2 (pin 42) starts, and MPU starts operation. [the 400 Hz clock can be observed at pins (1) and (42) using an oscilloscope]

Step 2:

When the RESET terminal (pin 7) is in the RESET mode at "H" level (3 V or more), the output terminals (pins 8~32) are set to "L" level (0.7 V or less) and the MPU is kept at stop at the first step of the internal program.

Step 3:

When the RESET terminal (pin 7) is set to "L" level (0.7V or less) several hundred seconds after power is supplied, and RESET is released, MPU starts operation following the internal program.

Step 4:

MPU discriminates power supply frequency at the first place as soon as RESET is released. That is, MPU distinguishes 50Hz in case a periodic time of clock at the INT terminal is more than 18.3 msec, from 60Hz in case the time is less than it.

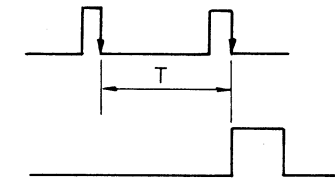

In case T > 18.3 msec, a flag of 50 Hz is formed inside of MPU.

Fig. 3

Step 5:

When the above operation is complete, MPU outputs "H" level for 2 sec to 0-ADMS (pin 17) to perform ADMS. (ADMS LED indicator lights with Q 276 set to ON) When a cassette has been inserted at that time, and when the CST switch is set to ON, the fast that K-CST (pin 40) is set to "L" level is read, and slack in the cassette is removed.

Step 6:

When ADMS is completed, MPU outputs a rectangular wave (period; 3 ~ 4 msec) to K-SCAN terminal to start key input. (See Figure-3). When key input is not present, a rectangular wave the same as that appearing at K-SCAN terminal is output to key terminals (pin 33 ~ pin 40) via the resistor block R612. MPU inputs the "L" level (0.7 V or less) of the key input terminal when K-SCAN terminal is set to "H" level. That is, with the switch set to ON, the 1st key connected to GND terminal is read. When this input condition does not change for all 32 periods of the rectangular wave, the MPU judges that the key input has been performed and operates corresponding to the key input.

The MPU inputs the "H" level of the key input when the K-SCAN terminal is set to "L" level. That is, MPU reads the 2nd key connected to +5V via the resistor, with the switch set to ON.

● 2nd KEY

TIMER REC: Set to REC/PLAY when it is ON after
TIMER PLAY: Set to PLAY when it is ON after
 POWER ON ADMS is complete.
 Set to REWIND when it is ON after
 ATUO-STOP in PLAY mode.
 Set to PLAY when it is ON after auto-
 stop in REWIND mode.

COUNTER

0 PLAY: Set to PLAY when it is set to "H" level
 in REWIND mode.

ADMS: ADMS starts with the switch set to ON
 during STOP mode.

6-4. Mechanism display LEDs driver circuit

Mechanism display LEDs driver circuit is composed of IC402 (4/7) (PLAY ▶), IC402 (7/7) (PAUSE II), Q428 (REC MUT ●), and Q429 (REC ●). The PLAY LED driver IC402 (4/7) out of these is used with PLAY solenoid driver together.

7. F.L. (Fluourescent Lamp)

Terminals 2 to 5 and 8 to 15 of MPU are control outputs for F.L. plate. Out of four figures, figure 100 is controlled by grid G_0 , 10^1 by G_1 , 10^2 by G_2 and 10^3 by G_3 (Fig-6). In the meantime, each figure has seven segments of a ~ g in its plate (Fig-5).

When segments are set to "H" level at the same time as grid, the segments lights up.

For instance, in case the display shows 00.01 each terminal follows flow-chart illustrated as Fig-7.

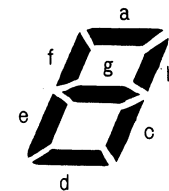

Fig-5

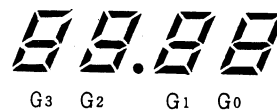

Fig-6

6-2. MPU RESET circuit

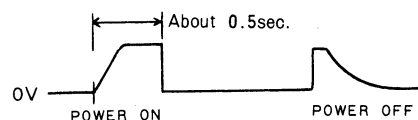

Fig-4

MPU RESET circuit is connected with NAND of IC403 (3/4). When power is turned on, the input of NAND is changed from Low level ("L") to High level ("H") after about 0.5 second by a time constant of R484 and C408. It means that the level at the RESET terminal of MPU (pin-7) maintains "H" level - RESET condition - when switching power on, but it turns to "L" level after about 0.5 second. On the other hand, when power is switched off, the input of NAND is turned to "L" level because Q433 is set to on by a discharge time constant of R505 and C415. So that, the level at the RESET terminal of MPU (pin-7) becomes "H" level and MPU is reset.

6-3. LINE MUTE circuit

MUTING is functioned with IC403 (4/4) for about 3 seconds after switching power on, so as to eliminate unnecessary noise to lead to LINE OUTPUTS, METERS and HEADPHONES. The output of IC403 (4/4) is set to "H" level by a time constant of R486 and C409 for about 3 seconds after power is turned on. Meanwhile, when turning power off, the input of IC403 (4/4) is set to "L" level by Q433 operation. So that, its output is turned to "H" level and LINE MUTING is functioned.

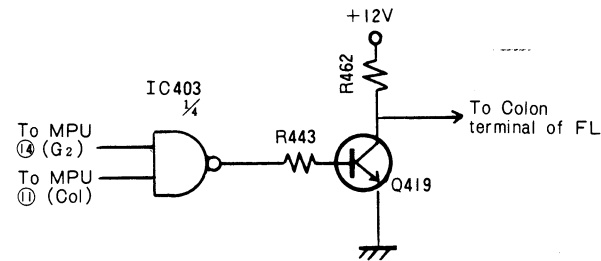

Fig-8

As the F.L. of AD-3700 has colons at each figure, it is necessary to put off colons of G_2 (10^2 figure) and G_3 (10^3 figure) during the F.L. being displayed as Watch.

Therefore, when G_2 (terminal 14) is set to "H" level at the same time as Col (terminal 11) with using of NAND of IC 403 (1/4), designated colon lights up.

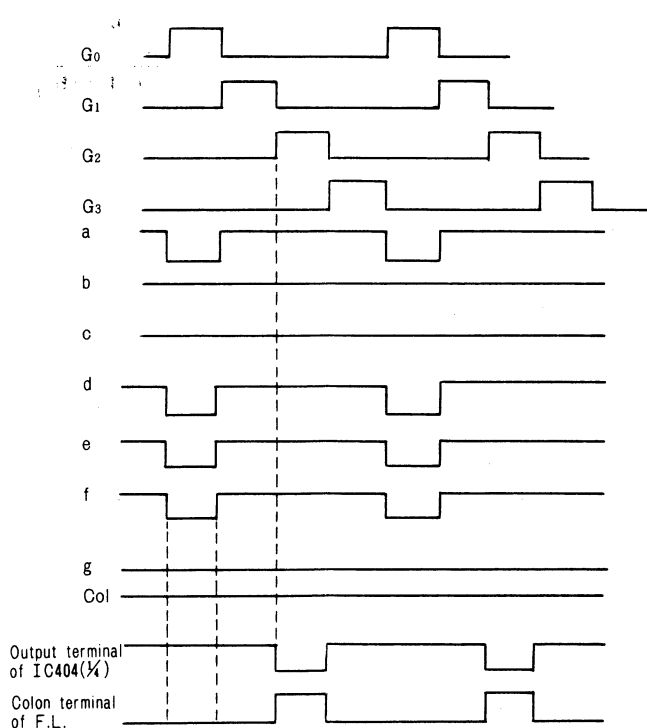
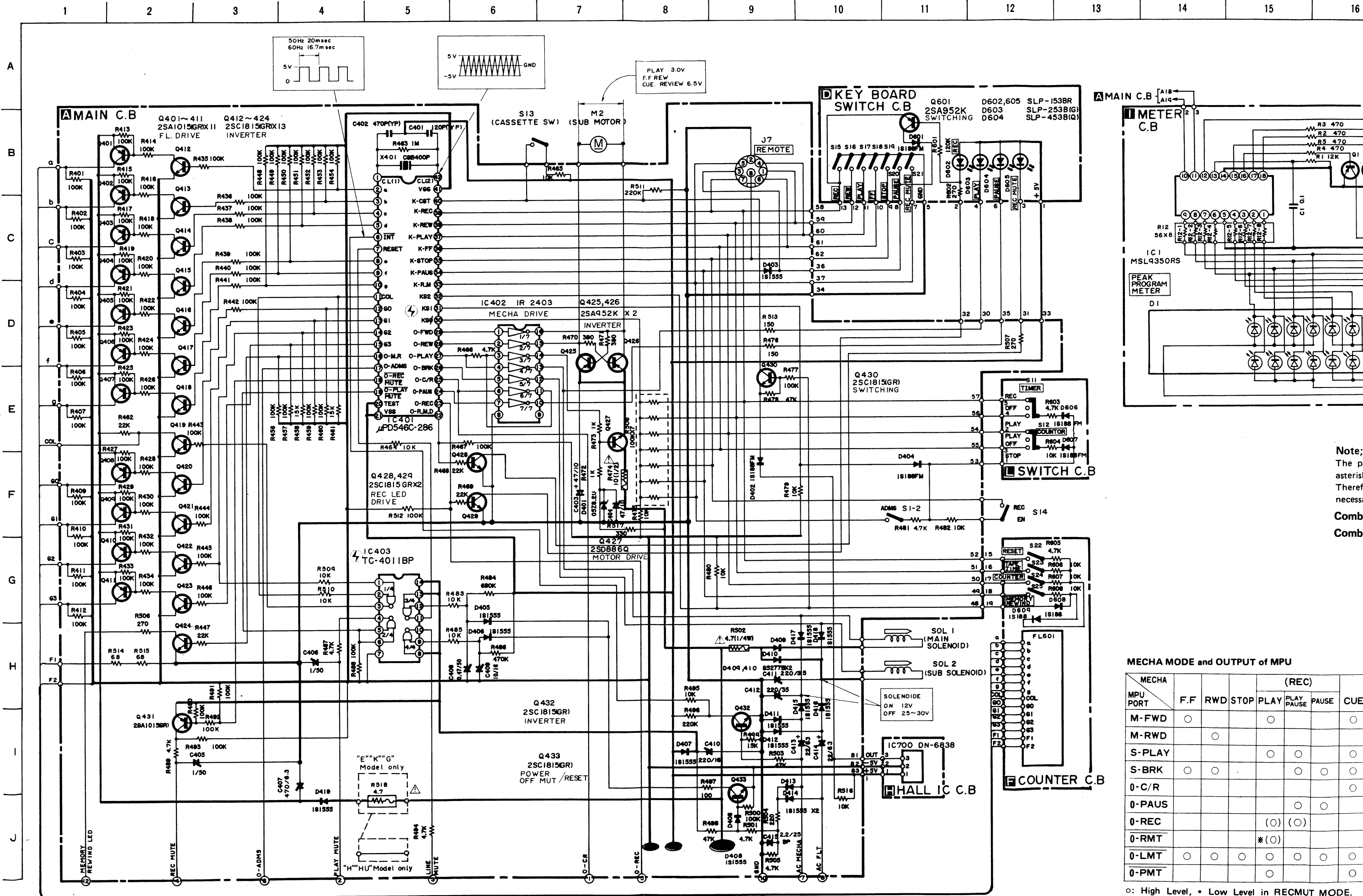

Fig-7

☆☆☆☆☆☆☆☆☆☆☆☆☆☆☆☆☆☆☆☆ MEMO ☆☆☆☆☆

SCHEMATIC DIAGRAM-2



Note: The p asterisk Theref necessi Comb Comb

MECHA MODE and OUTPUT of MPU

MPU PORT	MECHA MODE						
	F.F	RWD	STOP	PLAY	PLAY PAUSE	PAUSE	CUE
M-FWD	○			○			○
M-RWD		○					
S-PLAY				○	○		○
S-BRK				○	○	○	○
0-C/R					○		○
0-PAUS					○		
0-REC				(○)	(○)		
0-RMT				* (○)			
0-LMT	○	○	○	○	○	○	○
0-PMT				○			○

○: High Level, * Low Level in RECMUT MODE.

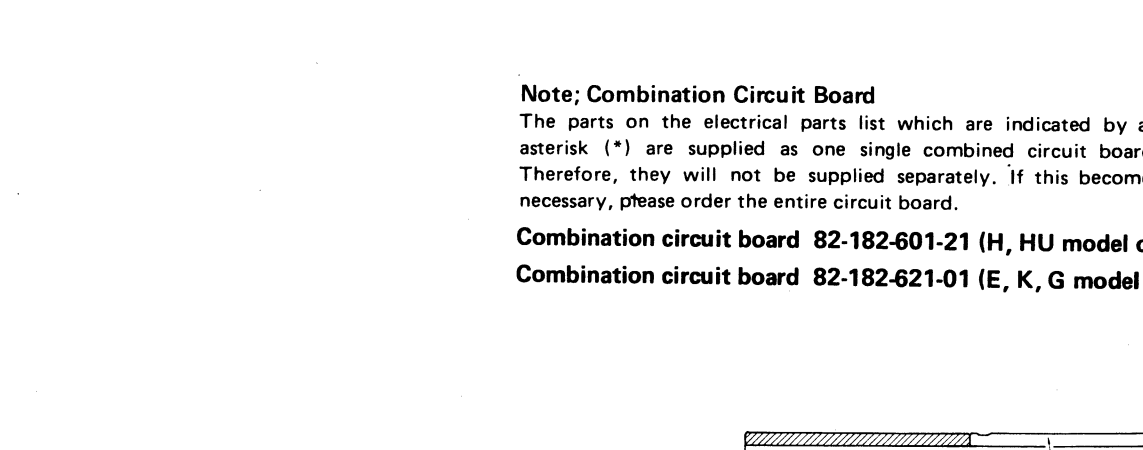
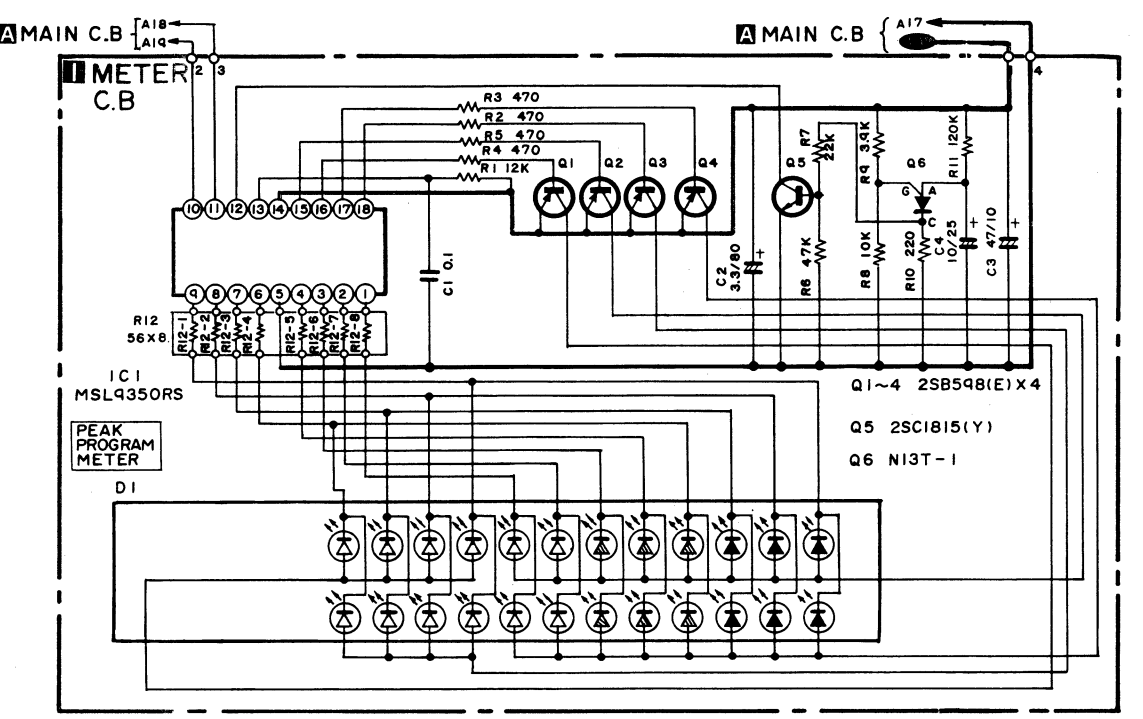
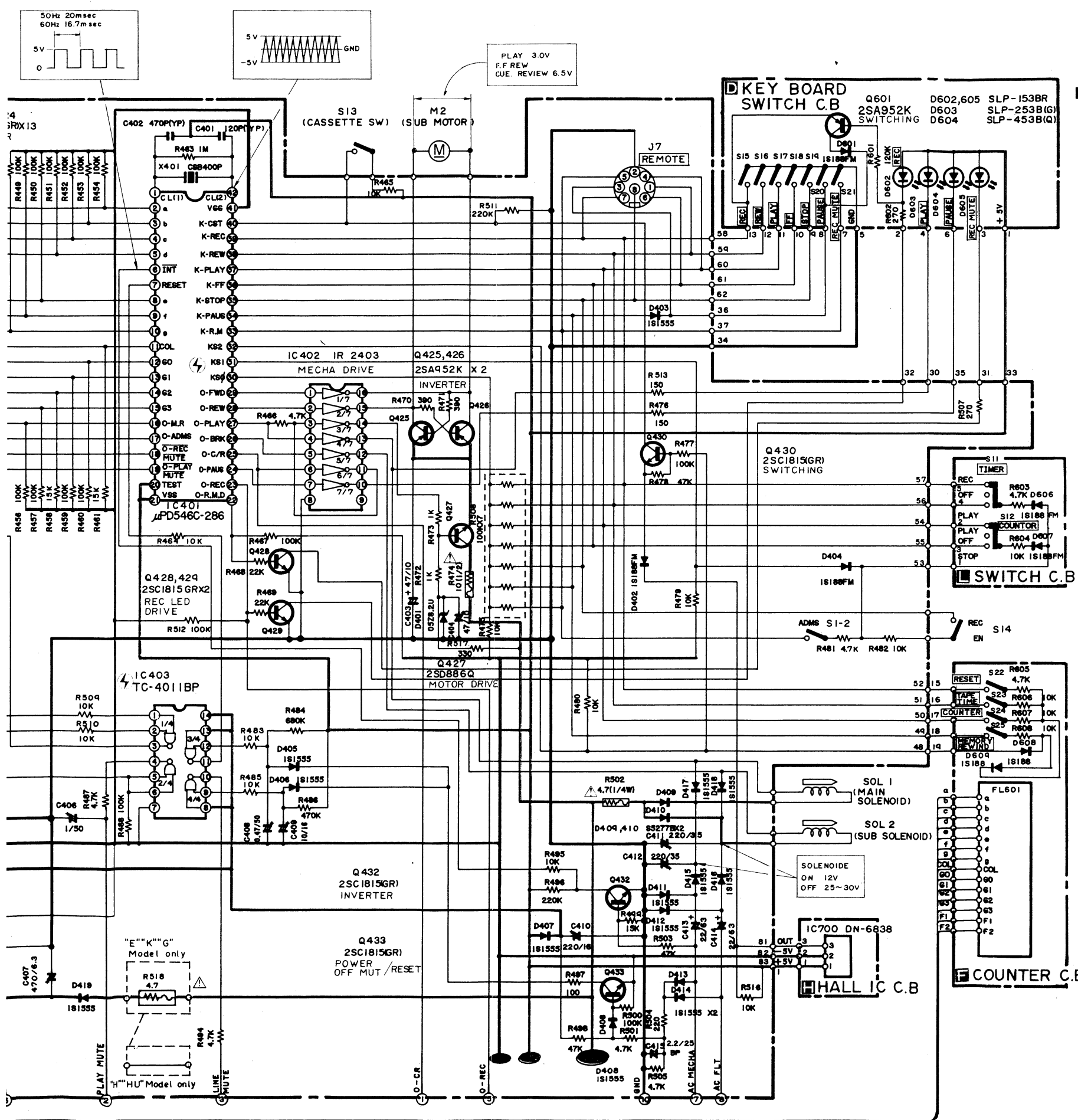
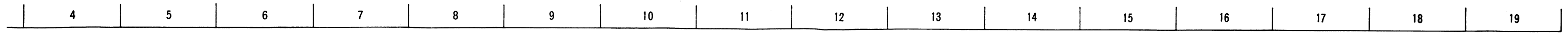

Note; Combination Circuit Board
 The parts on the electrical parts list which are indicated by an asterisk (*) are supplied as one single combined circuit board. Therefore, they will not be supplied separately. If this becomes necessary, please order the entire circuit board.
Combination circuit board 82-182-601-21 (H, HU model only)
Combination circuit board 82-182-621-01 (E, K, G model only)

MECHA MODE and OUTPUT of MPU

MECHA MPU PORT	MECHA			(REC)			RE-VIEW
	F.F	RWD	STOP	PLAY	PLAY PAUSE	PAUSE	
M-FWD	○			○			○
M-RWD		○					○
S-PLAY				○	○	○	○
S-BRK	○						○
0-C/R							○
0-PAUS					○	○	○
0-REC				(○)	(○)		○
0-RMT				*(○)			○
0-LMT	○	○	○	○	○	○	○
0-PMT				○			○

○: High Level, * Low Level in RECMUT MODE.

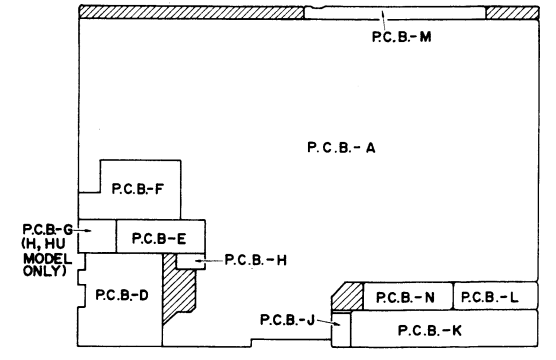

WIRING-1

1 2 3 4 5 6 7 8 9 10 11

A B C D E F G H I J K L M

MAIN C.B

9. REC/PB Frequency Characteristic Adjustment

- METAL tape
- Settings:
 - Test tape: TTA-119MX
 - TAPE SELECTOR switch: METAL
 - Input signal: 1 kHz, 30 mV
 - Output level: MAX
 - Adjustment locations: SFR151 (L-ch), SFR152 (R-ch)
- Method:
 - Make the characteristics identical to the 7. REC/PB frequency characteristic adjustment.
 - Adjust that the LINE output is made 55 ± 2mV, made 55 ± 2mV.
- CrO₂ tape
- Settings:
 - Test tape: TTA-119G
 - TAPE SELECTOR switch: CrO₂
 - Adjustment locations: SFR153 (L-ch), SFR154 (R-ch)
- Rating: 55 ± 2mV
- LH tape
- Settings:
 - Test tape: TTA-119J
 - TAPE SELECTOR switch: LH
 - Adjustment locations: SFR155 (L-ch), SFR156 (R-ch)
- Rating: 55 ± 2mV

6. Level Indicator Adjustment

- Settings:
 - Test tape: TTA-119MX
 - Input signal: 1 kHz, 300mV
 - Monitor switch SOURCE
 - Output level: Max
 - Adjustment locations: SFR101 (L-ch), SFR102 (R-ch)
- Method:
 - Apply a signal (1 kHz, 300 mV) and adjust the recording level so that the output is 520 mV. Adjust so that the 0 dB LED indicator lights at that time.
 - Check that the +2 dB LED lights when the input is resisted by 2 dB.

3. Play back Frequency Characteristic Adjustment

- Settings:
 - Test tape: TTA 117E
 - TAPE SELECTOR switch: CrO₂
 - Adjustment locations: SFR1 (L-ch), SFR2 (R-ch)
- Method:
 - Play back the test tape and adjust SFR 1,2 so that the 1 kHz and 10kHz output deviation are +0.5 dB ± 0.5 dB

4. Play back Level Adjustment

- Settings:
 - Test tape: TTA 161
 - TAPE SELECTOR switch: LH
 - Adjustment locations: SFR3 (L-ch), SFR4 (R-ch)
- Method:
 - Play back the test tape and adjust so that the LINE output is 730 ± 40mV

8. LH REC/PB Frequency Characteristic Adjustment

- Settings:
 - Recording mode
 - Test tape: TTA-119J
 - LH BIAS FINE: Center
 - TAPE SELECTOR switch: LH
 - Input signal: 1 kHz, 30mV
 - Adjustment locations: SFR203
- Method:
 - Make the characteristics identical to the 7. REC/PB frequency characteristic adjustment.
- Rating: 1.0 ± 0.5 dB

7. CrO₂ REC/PB Frequency Characteristic Adjustment

- Settings:
 - Recording mode
 - Test tape: TTA-119G
 - Output level: MAX
 - TAPE SELECTOR switch: CrO₂
 - Input signal: 1 kHz, 30mV
 - Adjustment locations: SFR201 (L-ch), SFR202 (R-ch)
- Method:
 - Supply a 1 kHz, 30 mV signal and adjust the recording level so that the LINE output is made 55mV. Record and playback the 1 kHz and 10 kHz signals and adjust so that the 1 kHz and 10 kHz outputs are set to -1.0 dB.
- Rating: 1.0 ± 0.5 dB
- METAL tape
- Setting:
 - Test tape: TTA-119MX
- Rating: 1.0 ± 1.0 dB

5. Bias Osc. Frequency Adjustment

- Settings:
 - Recording mode
 - Test point: TP13
 - Adjustment locations: L201
- Method:
 - Adjust L201 so that the bias OSC. frequency become 85 kHz ± 0.1 kHz.

10. Erase Head Adjustment

- Settings:
 - Test tape: TTA-119MX
 - Tape selector switch: METAL
 - Input signal: 125 Hz, 300 mV
 - Output level: Max
 - Adjustment location: Erase head adjustment screw
- Method:
 - Record a signal (125 Hz, 300 mV) for approx. 15 sec. and then rewind the tape. Erase the signal with no input and adjust so that the erase ratio is 60 dB or more for both the L and R channels.
 - Check that no overerasing of the opposite tracks occurs.

2. Azimuth Adjustment

- Adjustment location: Azimuth adjusting screw

TP13 BIAS OSC. FREQ. TEST POINT

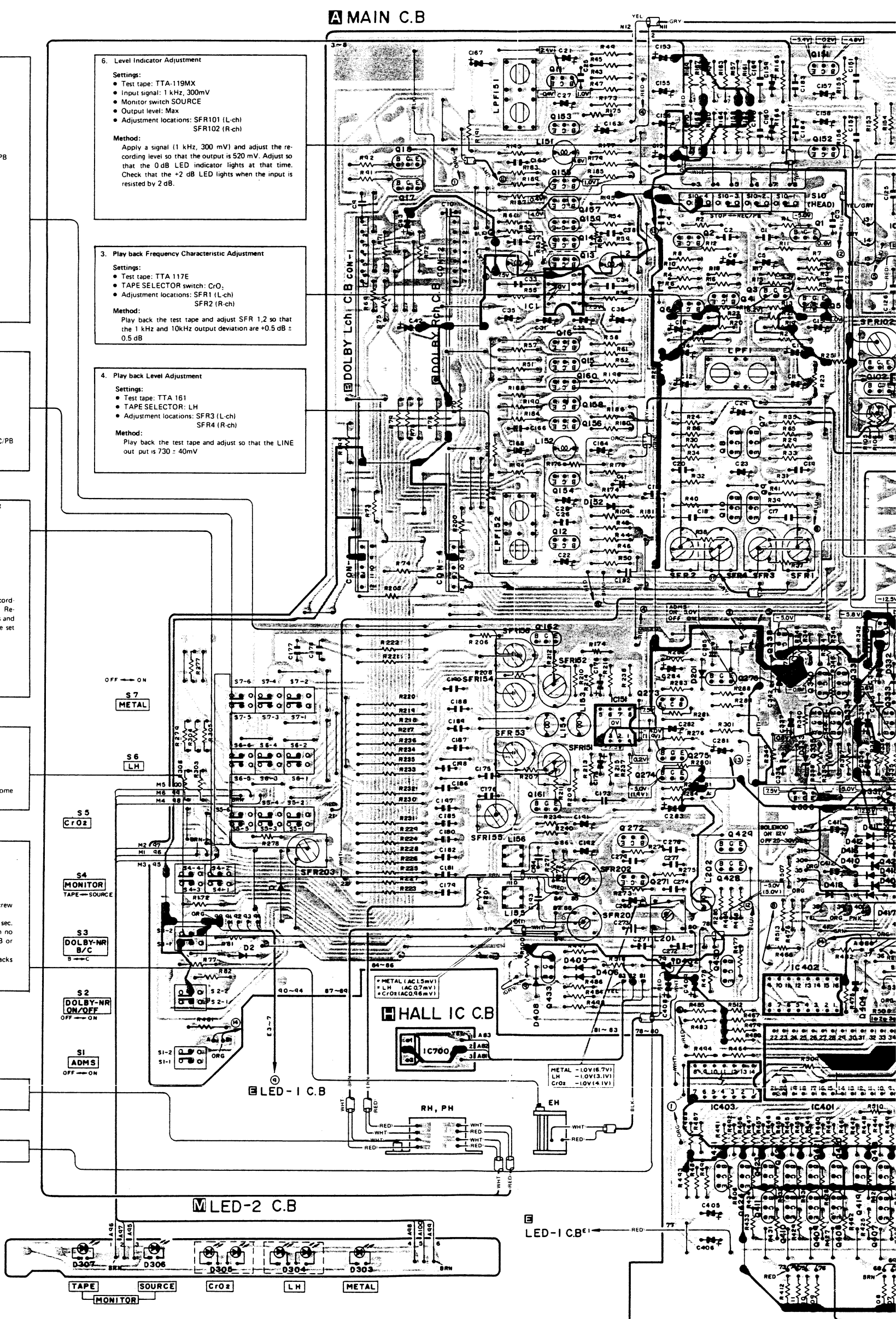

HALL IC C.B

LED-1 C.B

LED-2 C.B

LED-1 C.B

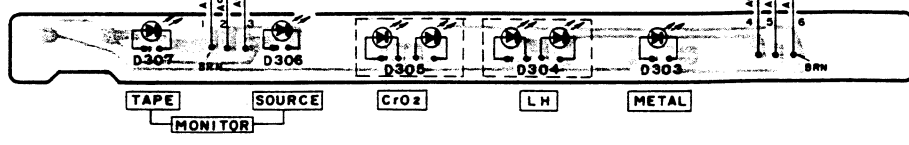

NOTES (1) B(+) Pattern ■ B(-) Pattern ▨ Others pattern
 (2) The voltage is the reference value measured with a tester (20 K ohms/V DC) when there are no signals. An asterisk (*) indicates that the value was measured with a vacuum-tube voltmeter during recording.

8 9 10 11 12 13 14 15 16 17 18 19

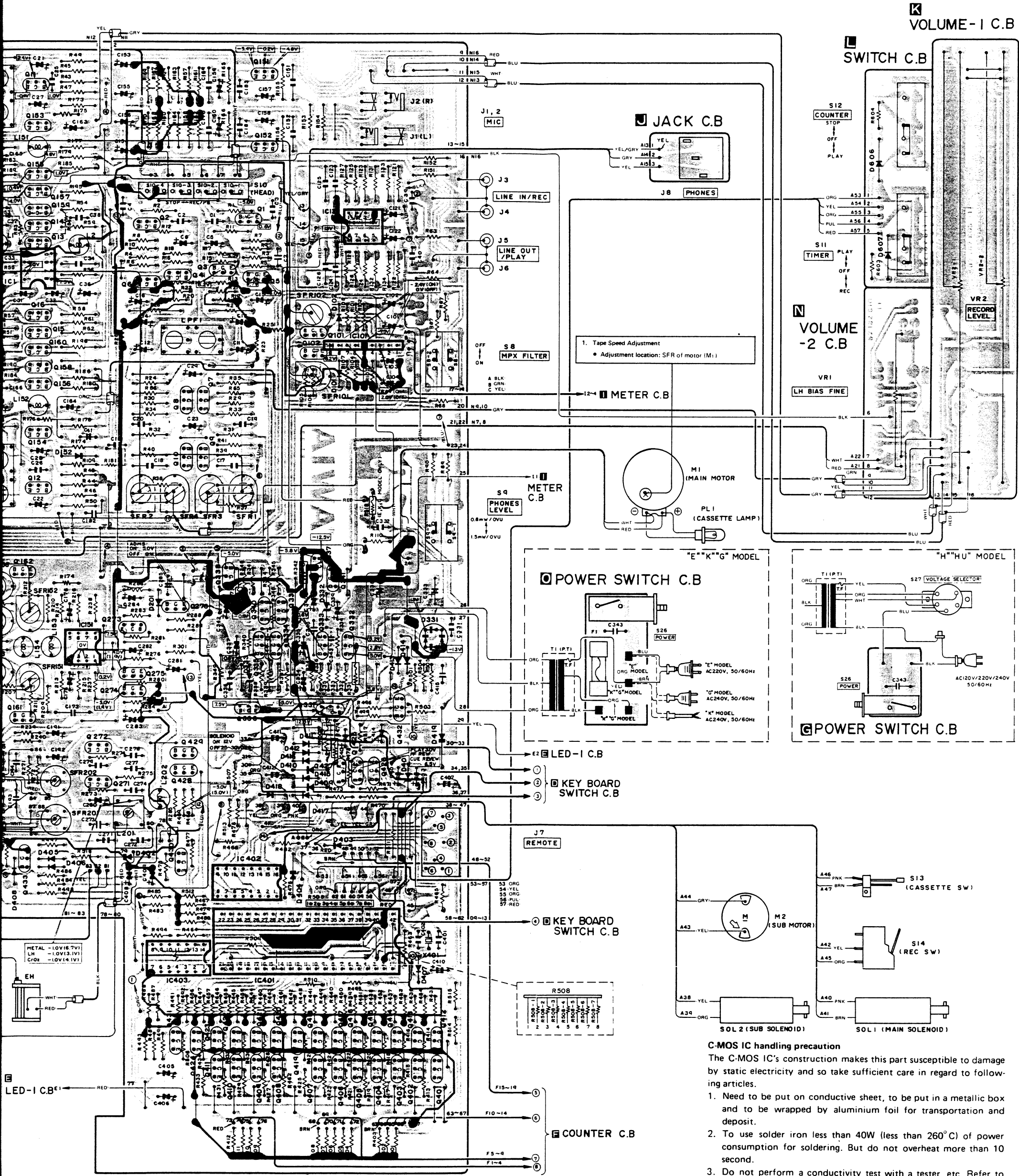

VOLUME-1 C.B

SWITCH C.B

JACK C.B

VOLUME-2 C.B

POWER SWITCH C.B

POWER SWITCH C.B

LED-I C.B

KEY BOARD SWITCH C.B

KEY BOARD SWITCH C.B

COUNTER C.B

C-MOS IC handling precaution

The C-MOS IC's construction makes this part susceptible to damage by static electricity and so take sufficient care in regard to following articles.

1. Need to be put on conductive sheet, to be put in a metallic box and to be wrapped by aluminium foil for transportation and deposit.
2. To use solder iron less than 40W (less than 260°C) of power consumption for soldering. But do not overheat more than 10 second.
3. Do not perform a conductivity test with a tester, etc. Refer to the circuit voltages of each part.
4. The ICs on the electrical parts which are indicated by an C-MOS IC symbol mark (Ⓜ).

NOTES (1) B(+) Pattern B (-) Pattern Others pattern
 (2) The voltage is the reference value measured with a tester (20 K ohms/V DC) when there are no signals. An asterisk (*) indicates that the value was measured with a vacuum-tube voltmeter during recording.

WIRING-2

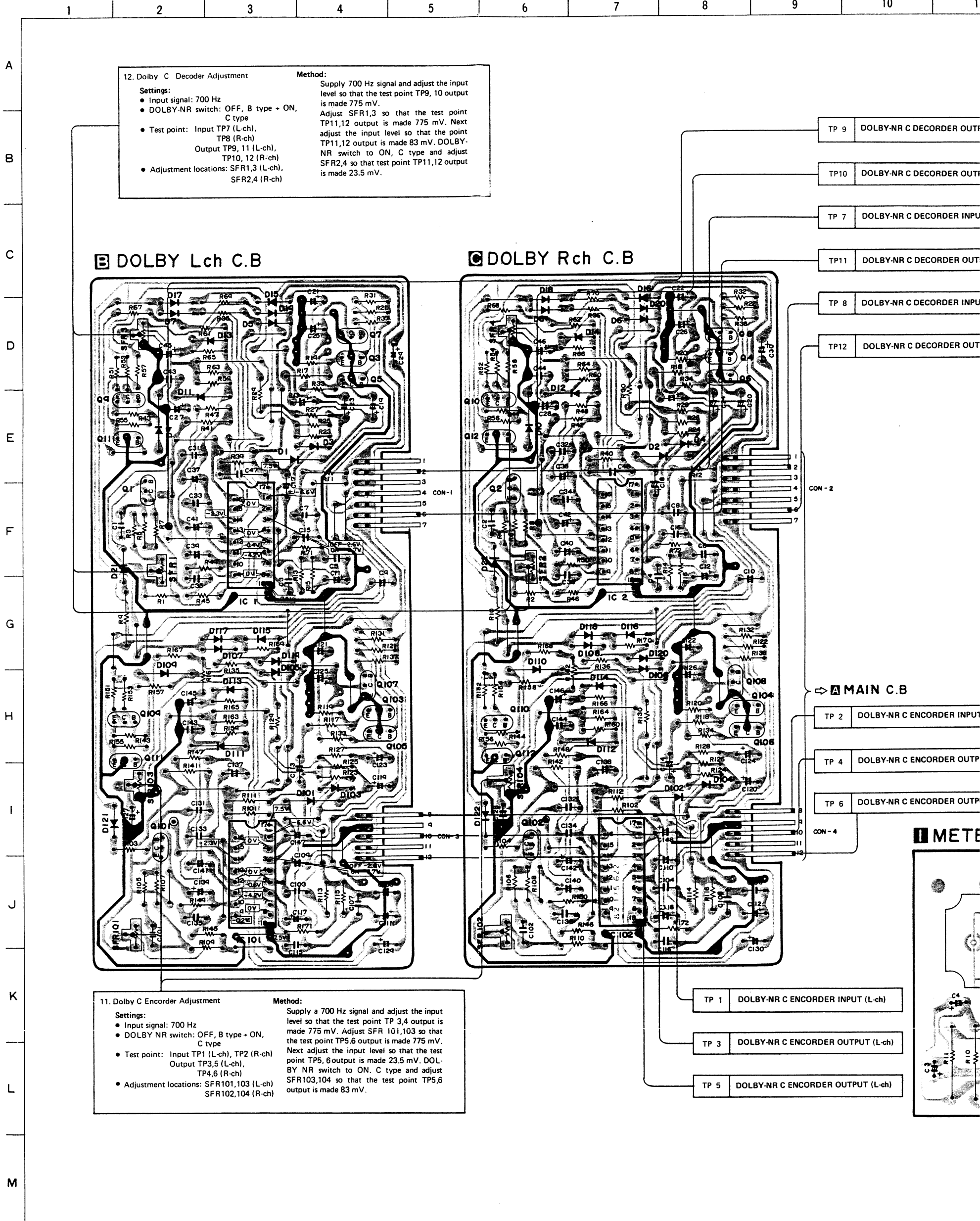

12. Dolby C Decoder Adjustment

Settings:

- Input signal: 700 Hz
- DOLBY-NR switch: OFF, B type - ON, C type
- Test point: Input TP7 (L-ch), TP8 (R-ch)
- Output TP9, 11 (L-ch), TP10, 12 (R-ch)
- Adjustment locations: SFR1,3 (L-ch), SFR2,4 (R-ch)

Method:

Supply 700 Hz signal and adjust the input level so that the test point TP9, 10 output is made 775 mV. Adjust SFR1,3 so that the test point TP11,12 output is made 775 mV. Next adjust the input level so that the test point TP11,12 output is made 83 mV. DOLBY-NR switch to ON, C type and adjust SFR2,4 so that test point TP11,12 output is made 23.5 mV.

DOLBY Lch C.B

DOLBY Rch C.B

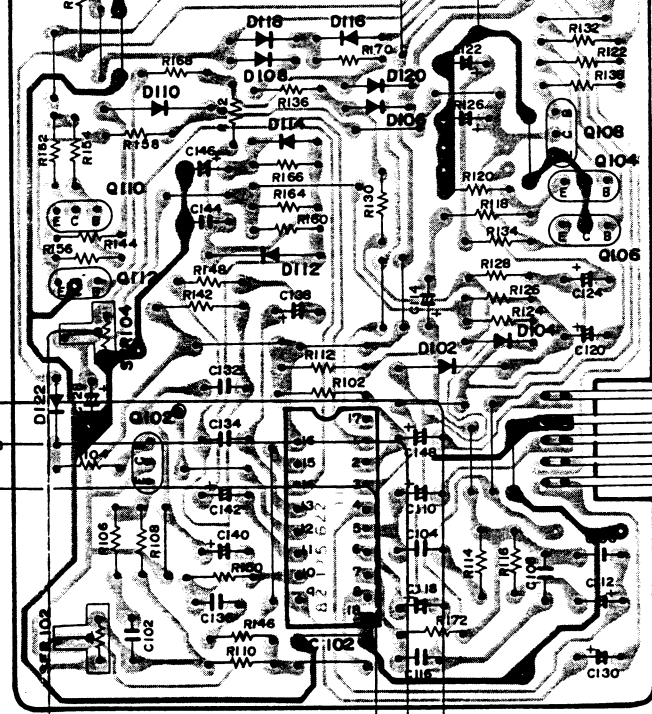
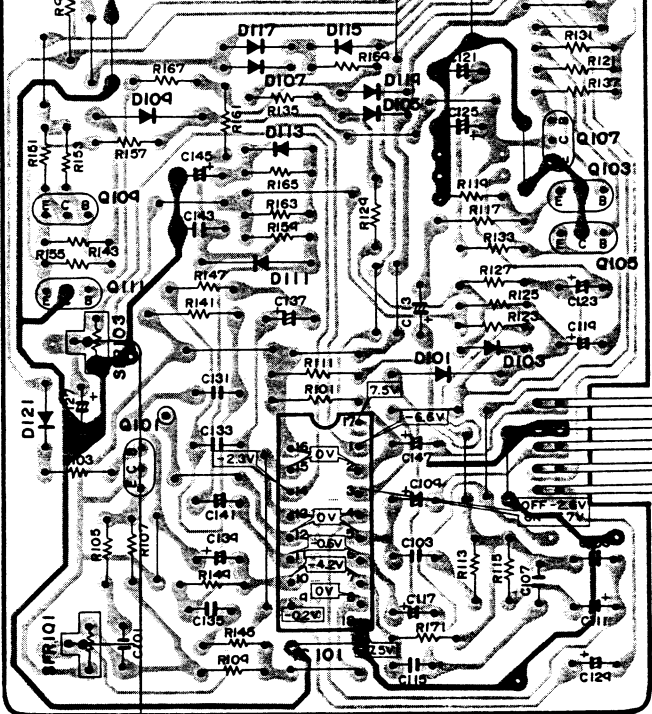
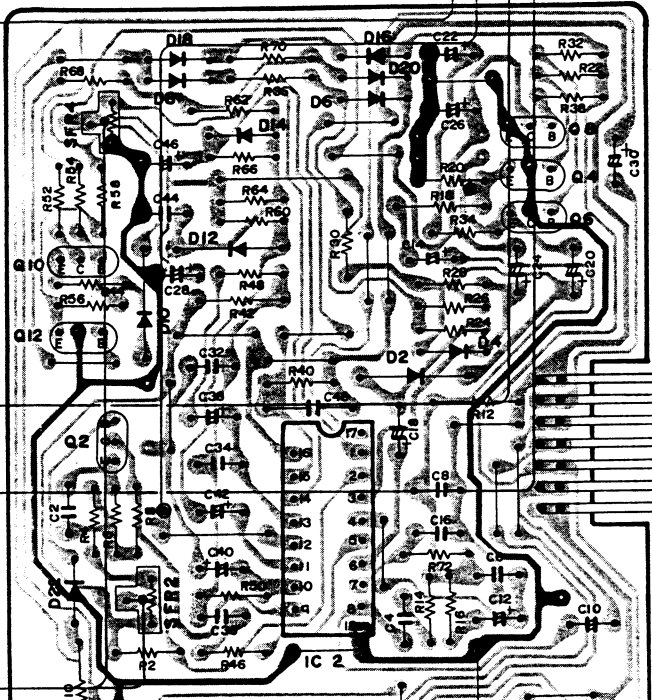
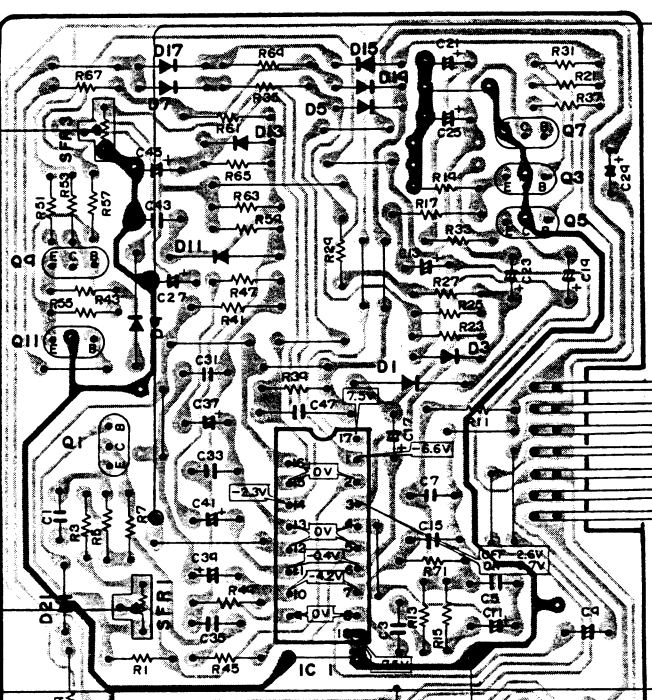

11. Dolby C Encoder Adjustment

Settings:

- Input signal: 700 Hz
- DOLBY NR switch: OFF, B type - ON, C type
- Test point: Input TP1 (L-ch), TP2 (R-ch)
- Output TP3,5 (L-ch), TP4,6 (R-ch)
- Adjustment locations: SFR101,103 (L-ch), SFR102,104 (R-ch)

Method:

Supply a 700 Hz signal and adjust the input level so that the test point TP 3,4 output is made 775 mV. Adjust SFR 101,103 so that the test point TP5,6 output is made 775 mV. Next adjust the input level so that the test point TP5,6 output is made 23.5 mV. DOLBY NR switch to ON, C type and adjust SFR103,104 so that the test point TP5,6 output is made 83 mV.

- TP 9 DOLBY-NR C DECODER OUTPUT (L-ch)
- TP10 DOLBY-NR C DECODER OUTPUT (R-ch)
- TP 7 DOLBY-NR C DECODER INPUT (L-ch)
- TP11 DOLBY-NR C DECODER OUTPUT (L-ch)
- TP 8 DOLBY-NR C DECODER INPUT (R-ch)
- TP12 DOLBY-NR C DECODER OUTPUT (R-ch)

- MAIN C.B**
- TP 2 DOLBY-NR C ENCODER INPUT (L-ch)
 - TP 4 DOLBY-NR C ENCODER OUTPUT (L-ch)
 - TP 6 DOLBY-NR C ENCODER OUTPUT (R-ch)

- TP 1 DOLBY-NR C ENCODER INPUT (L-ch)
- TP 3 DOLBY-NR C ENCODER OUTPUT (L-ch)
- TP 5 DOLBY-NR C ENCODER OUTPUT (L-ch)

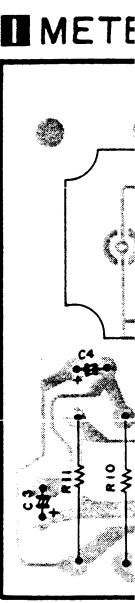

C) when there are no signals.
voltmeter during recording.

8 9 10 11 12 13 14 15 16 17 18 19

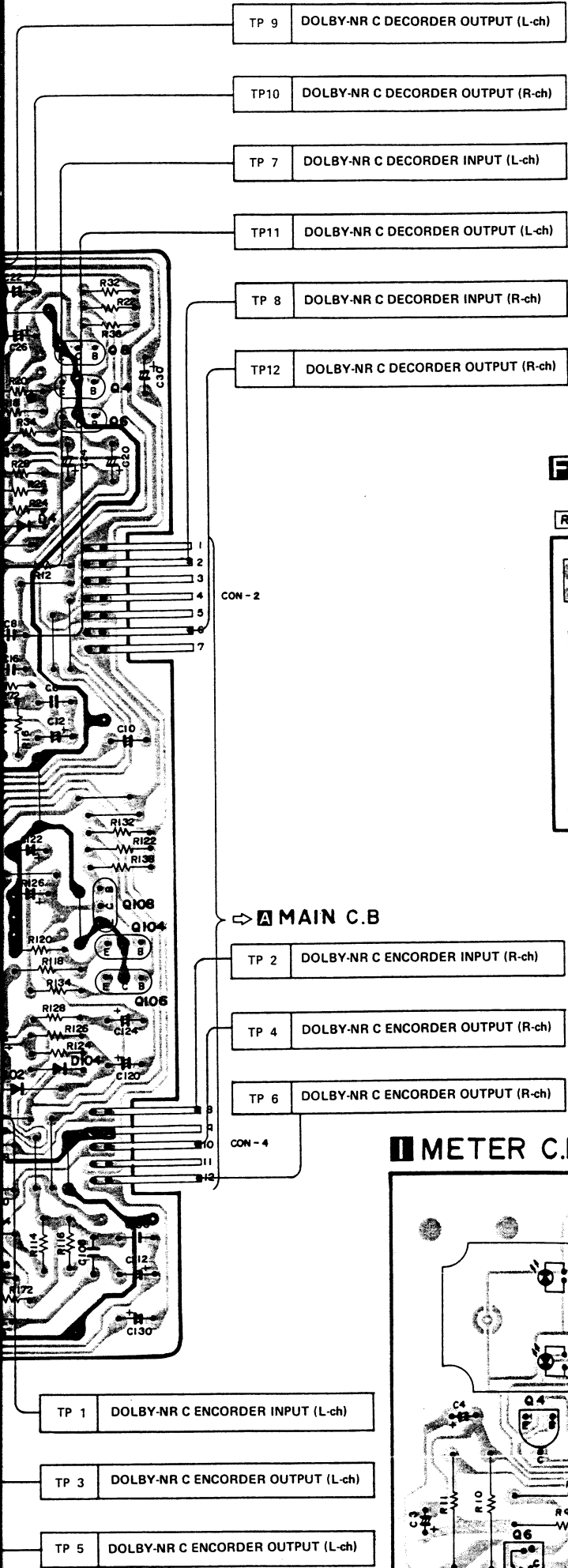

KEY BOARD SWITCH C.B

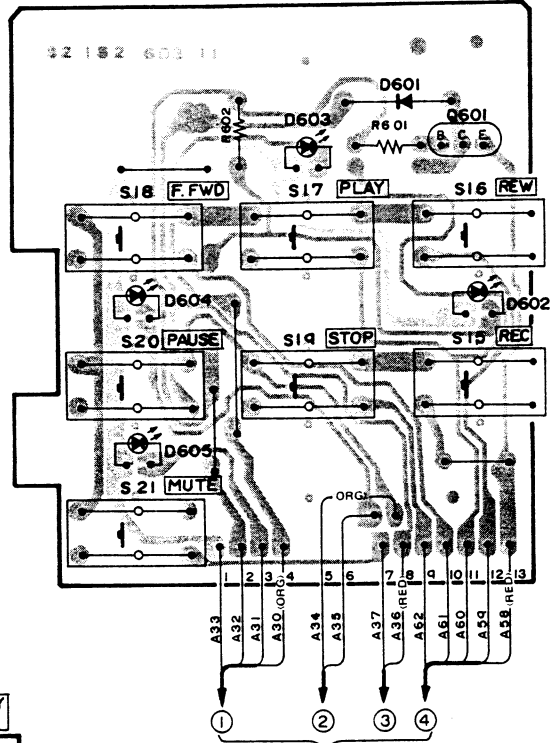

COUNTER C.B

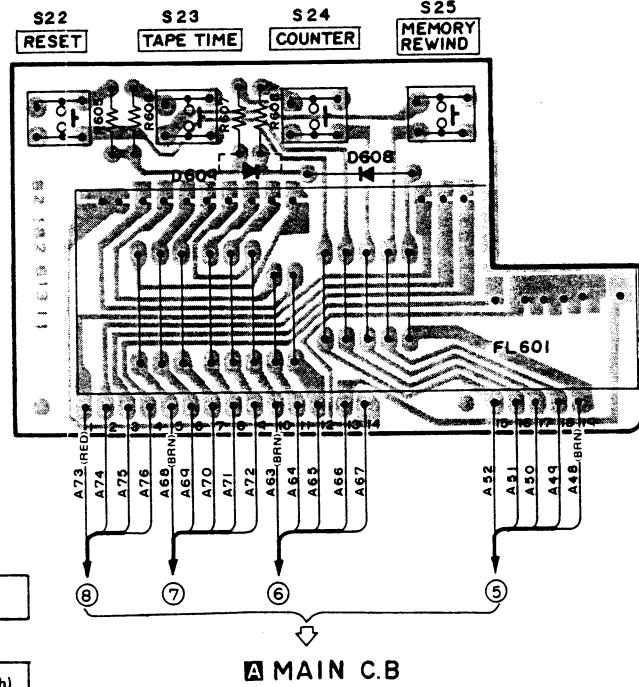

MAIN C.B

LED-1 C.B

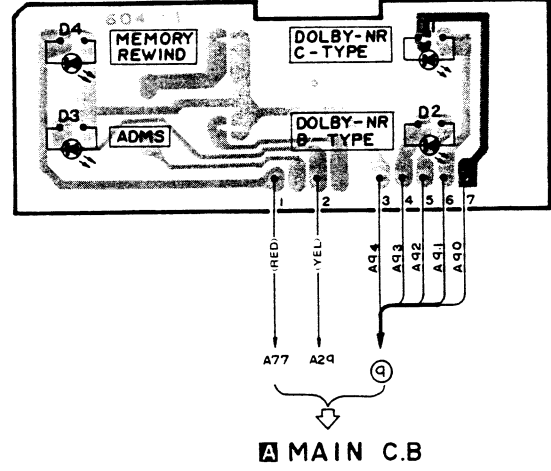

METER C.B

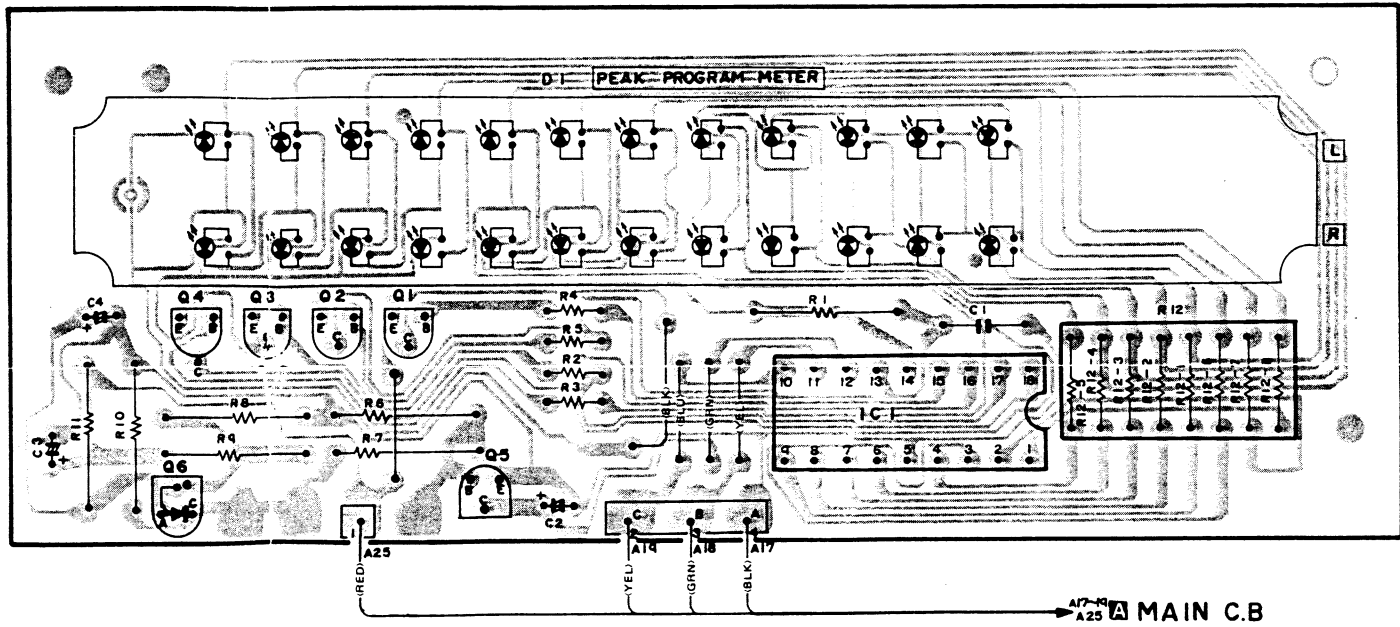

MAIN C.B