

STEREO CASSETTE DECK WITH DOLBY-NR SYSTEM

MODEL NO. AD-6600U, E, K

For Service Manuals Contact
MAURITRON TECHNICAL SERVICES
 8 Cherry Tree Rd, Chinnor
 Oxon OX9 4QY
 Tel: 01844-351694 Fax: 01844-352554
 Email: enquiries@maurtron.co.uk

AIWA®

(SERVICE MANUAL)

Cord No.. 04-660-000-46

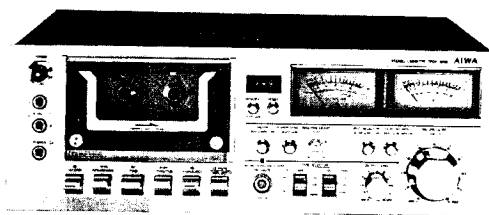

10732

DATE OF ISSUE 11/1978

SPECIFICATIONS

Semiconductors:	10 IC's, 57 transistors, 33 diodes, 2 LED's (U model) 10 IC's 69 transistors, 34 diodes, 2 LED's (E, K model)	Channel separation:	More than 28 dB (1 kHz, 0 VU)
Power source:	AC 120 V 60 Hz (U model) AC 110~120V/220~240V switchable 50/60 Hz (E model) AC 120V/240V switchable 50/60 Hz (K model)	Cross talk:	More than 60 dB (1 kHz, 0 VU)
Power consumption:	10W (U model) 14W (E, K model)	Erasing ratio:	More than 60 dB (400 Hz, 0 VU, +10 dB)
Dimensions:	17-3/4"(W) x 5-15/16"(H) x 13"(D) [450(W) x 150(H) x 330(D)mm] (U model) 420(W) x 150(H) x 330(D) mm (E, K model)	Level drift:	Less than 0.5 dB (10 kHz, 0 VU)
Weight:	18.7 lbs (8.5 kg) (U model) 7.5 kg (E, K model)	VU meter display error:	0 VU ± 0.5 dB (0 VU)
Track type:	4 tracks 2 channel	Peak indicator hold time:	3 sec
Tape speed:	1-7/8 ips ± 1% (4.76 cm/sec ± 1%)	Bias frequency:	100 kHz
Automatic stop system:	Full auto stop	Frequency response:	LH tape 20 ~ 15,000 Hz 30 ~ 13,000 Hz (± 3 dB) Fe-Cr tape 20 ~ 17,000 Hz 30 ~ 15,000 Hz (± 3 dB) CrO ₂ tape 20 ~ 17,000 Hz 30 ~ 15,000 Hz (± 3 dB)
Automatic shut-off action time:	4 ± 1 sec	Rec mute crosstalk:	More than 63 dB (1 kHz, 0 VU, +10 dB)
Pinch roller pressure:	375 ± 30 g	Motor:	38 pulse FG servo motor
Take-up torque:	50 ± 10 g-cm	Head:	Ferrite guard head (FGH)
FF & rewind torque:	125 ± 25 g-cm	Input:	MIC: Max. input sensitivity 0.3 mV (200 Ω ~ 10 kΩ suitable) LINE IN/REC: Max. input sensitivity 50 mV (More than 50 kΩ)
FF & rewind time:	95 ± 1.5 sec	Output:	LINE OUT/PLAY: Standard output level 0.775V (Optimum load impedance more than 50 kΩ) PHONES: 0.175V (Load impedance 8Ω) (U model) 0.110V (Load impedance 8Ω) (E, K model)
Unattended recording action time:	3.2 ± 1.5 sec (at Power switch ON)		
Play back output:	1.05 ± 0.05V (LINE)		
Play back noise:	Less than 3.0/2.0 mV (CrO ₂ , Fe-Cr Dolby NR OFF/ON) Less than 4.0/2.5 mV (LH, Dolby NR OFF/ON)		
Rec./Pb. output:	0 VU ± 1 dB		
Rec./Pb. distortion:	Less than 2.0% (CrO ₂ , LH) Less than 1.5% (Fe-Cr)		
Rec./Pb. SN ratio:	More than 45/48 dB (400 Hz, 0 VU) (U-weighted)		

- Specifications and external appearance are subject to change without due to product improvement.
- Dolby Noise Reduction System is licensed from Dolby Laboratories Incorporated.
- The name "Dolby" and the "Double D" symbol are trade-

DISASSEMBLY INSTRUCTIONS

1. To Remove Cabinet

- 1) Remove 7 screws. (Refer to Fig. 1)

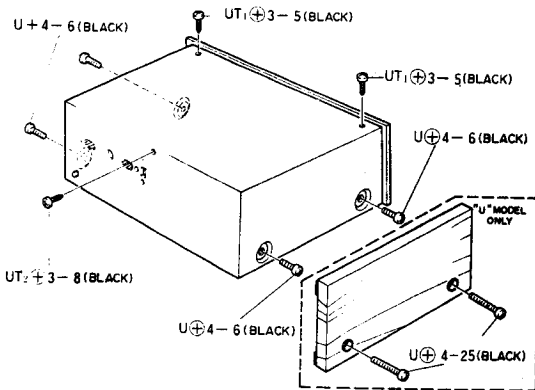

Fig. 1

2. To Remove Front Panel

- 1) Remove 2 screws, securing cassette window in place.
- 2) Pull out the control knobs.
- 3) Remove 7 screws. (Refer to Fig. 2)

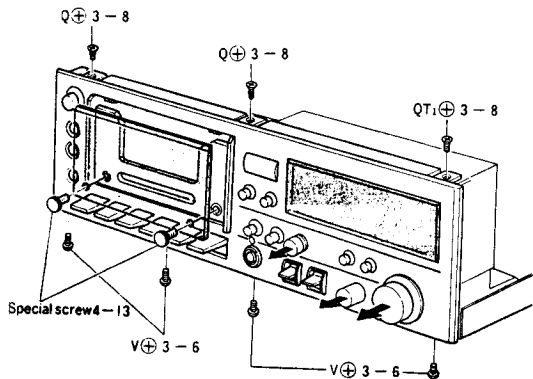

Fig. 2

3. To Remove Mechanism

- 1) Remove the counter belt.
- 2) Remove 7 screws. (Refer to Fig. 3)

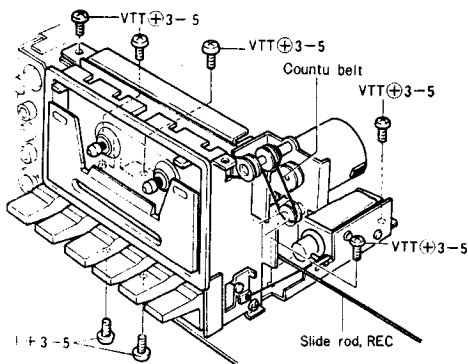

Fig. 3

4. To Remove Main Circuit Board

- 1) Remove the rod stoppers and take out the pus-rods. (Refer to Fig. 4)
- 2) Remove 2 screws. (Refer to Fig. 5)

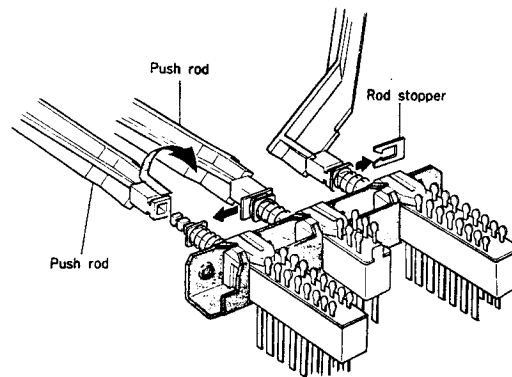

Fig. 4

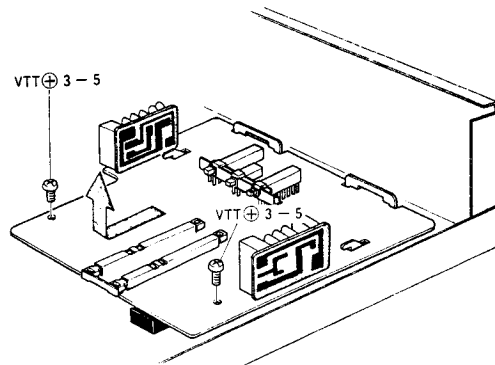

Fig. 5

5. To Remove Front Chassis

- 1) Remove the rod stoppers and take out the push-rods. (Refer to Fig. 4)
- 2) Remove 2 screws. (Refer to Fig. 6)

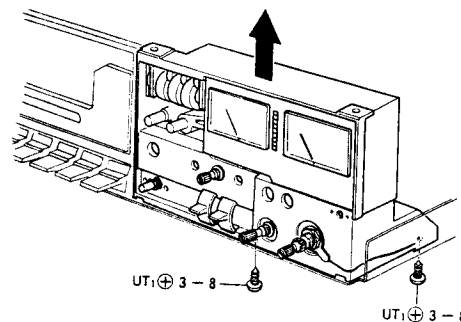

Fig. 6

For Service Manuals Contact
MAURITRON TECHNICAL SERVICES
 8 Cherry Tree Rd, Chinnor
 Oxon OX9 4QY
 Tel: 01844-351694 Fax: 01844-352554
 Email: enquiries@mauritron.co.uk

6. To Remove Switch Circuit Board.

- 1) Remove the rod stoppers and take out the push-rods. (Refer to Fig. 4)
- 2) Remove the levers.
- 3) Remove 4 screws and mounting nut. (Refer to Fig. 7)

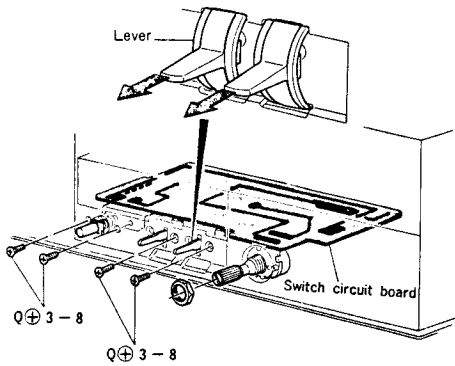

Fig. 7

9. To Remove LED (P) Circuit Board.

- 1) Remove mounting screws, securing meter plate in place.
- 2) Remove 2 screws. (Refer to Fig. 10)

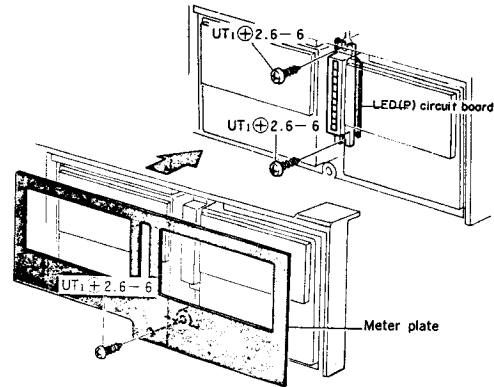

Fig. 10

7. To Remove Power Circuit Board.

- 1) Remove 3 screws. (Refer to Fig. 8)

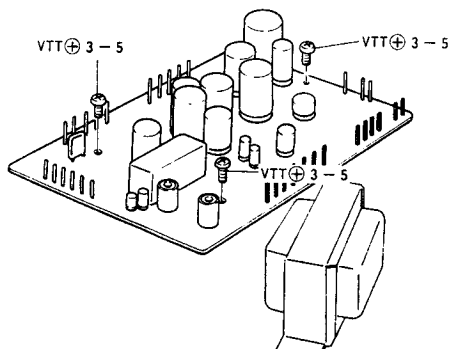

Fig. 8

10. To Remove Equalizer Circuit Board.

- 1) Remove the Circuit Board. (Refer to Fig. 11)

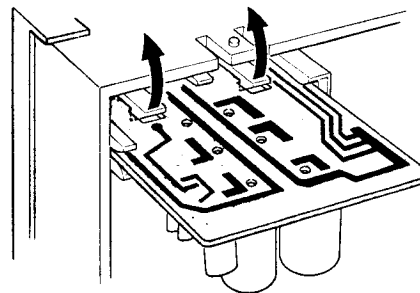
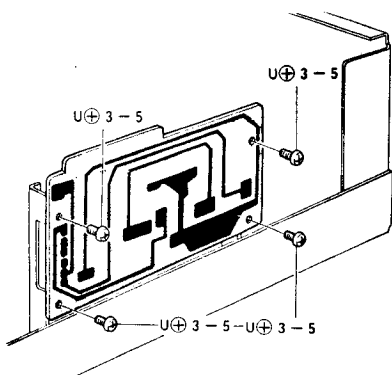

Fig. 11

8. To Remove Meter/Peak Circuit Board.

- 1) Remove 4 screws. (Refer to Fig. 9)



EXPLODED VIEW-1

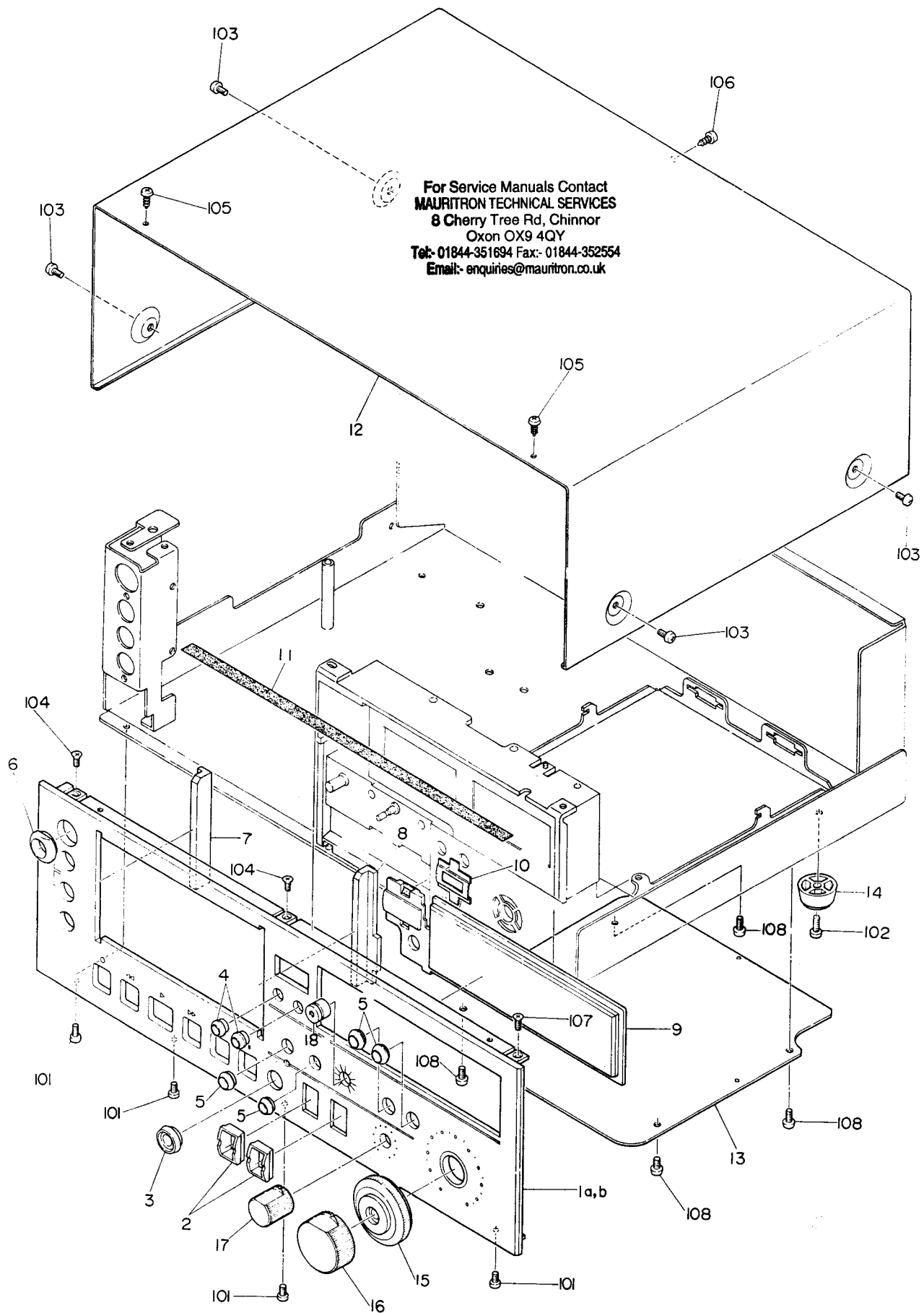

For Service Manuals Contact
MAURITRON TECHNICAL SERVICES
8 Cherry Tree Rd, Chinnor
Oxon OX9 4QY
Tel: 01844-351694 Fax: 01844-352554
Email: enquiries@mauritron.co.uk

MECHANICAL PARTS

PARTS LIST

* mark in this part list shows exclusive part (which is used) for only Model AD-6600.

Ref. No.	Part No.	Part No. Changed to	Description	Common Model	Q'ty
1~11	09-047-125-01		Panel Assembly – "E, K" model		
1~11	09-047-124-01		Panel Assembly – "U" model		
1-1a	82-306-005-01		Panel E, Front (E, K model only)	*	1
1-1b	82-306-026-01		Panel U, Front (U model only)	*	1
1-2	82-305-018-01		Cover, Bias		2
1-3	82-305-014-01		Ring, REC MUTE switch		1
1-4	82-305-012-01		Ring, Counter switch		2
1-5	82-305-016-01		Ring, Selector switch		4
1-6	82-478-012-01		Ring, Power button		1
1-7	82-305-004-01		Guide L, Cassette lid		1
1-8	82-305-005-01		Guide R, Cassette lid		1
1-9	82-305-006-01		Window, Meter		1
1-10	82-305-009-01		Cover, Counter		1
1-11	82-397-245-01		Himeron cloth, Cabinet	AD-6550	1
1-12	82-302-044-01		Steel cabinet B		1
1-13	82-399-029-01		Back cover	AD-6400	1
1-14	87-085-161-01		Foot		4
1-15	82-397-021-01		REC knob B ass'y	AD-6550	1
1-16	82-397-019-01		REC knob A ass'y	AD-6550	1
1-17	82-397-023-01		PB knob ass'y	AD-6550	1
1-18	82-306-012-01		Knob, Bias	*	1
1-19	87-052-090-01		Side panel L ass'y (U model only)		1
1-20	87-052-110-01		Side panel R ass'y (U model only)		1

EXPLODED VIEW-1 AD-6600U

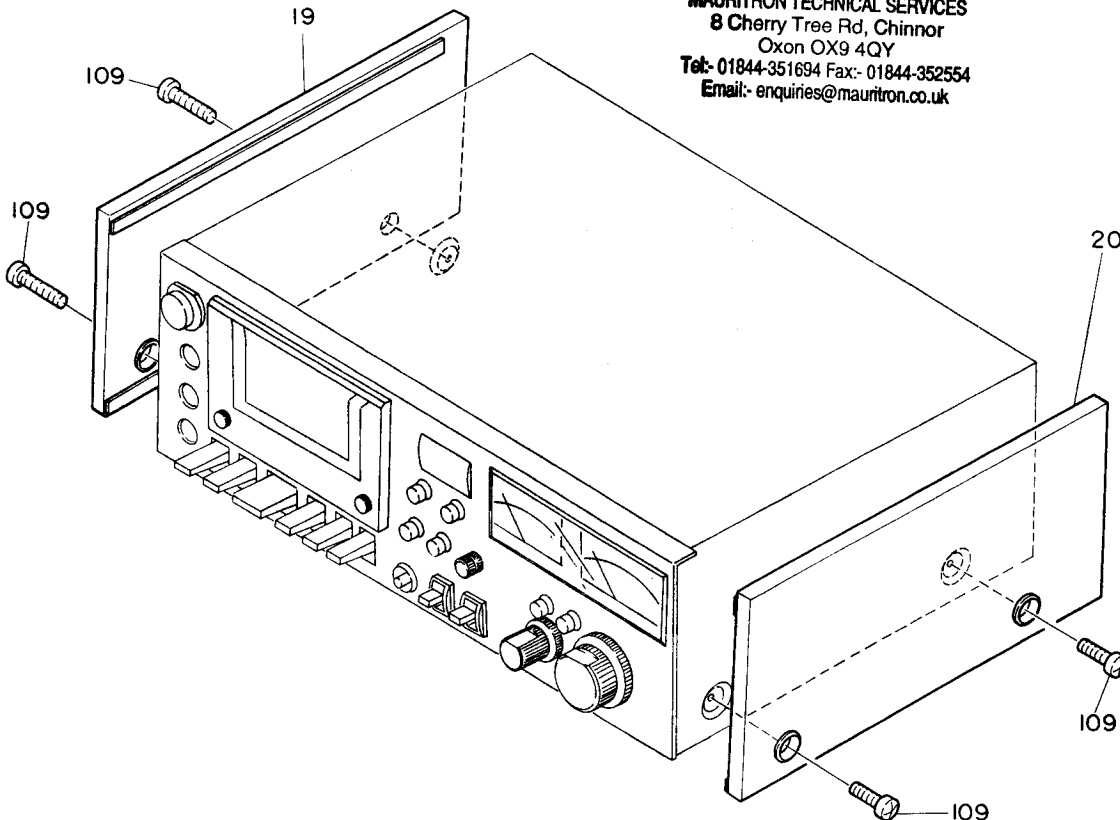

For Service Manuals Contact
MAURITRON TECHNICAL SERVICES
 8 Cherry Tree Rd, Chinnor
 Oxon OX9 4QY
 Tel: 01844-351694 Fax: 01844-352554
 Email: enquiries@mauritron.co.uk

EXPLODED VIEW-2

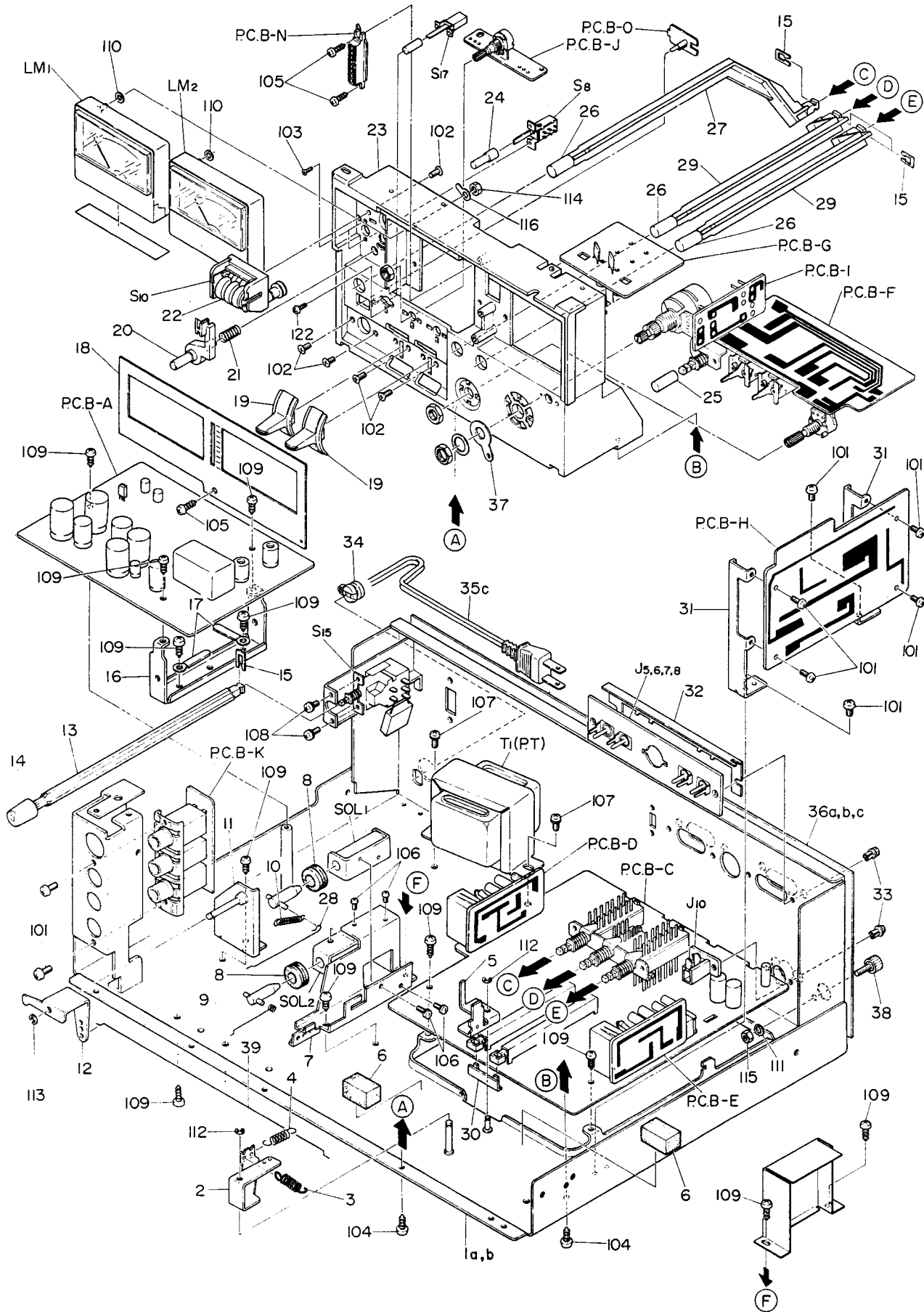

Ref. No.	Part No.	Part No. Changed to	Description	Common Model	Q'ty
2-1a	82-306-207-01		Amp. chassis ass'y (E, K model only)	*	1
2-1b	82-305-220-01		Amp. chassis ass'y (U model only)		1
2-2	82-397-241-01		REC lever B	AD-6550	1
2-3	82-379-335-01		Spring, REC-C		1
2-4	82-397-310-01		Spring, REC	AD-6550	1
2-5	82-397-248-01		REC lever C	AD-6550	1
2-6	81-301-040-01		Cushion, Circuit board		2
2-7	82-397-232-01		Holder, Solenoid	AD-6550	1
2-8	84-184-242-01		Rubber		2
2-9	82-397-318-01		Slide rod, PAUSE	AD-6550	1
2-10	82-272-424-01		Spring, Brake		1
2-11	82-305-202-01		REC holder ass'y		1
2-12	82-397-243-01		REC lever A	AD-6550	1
2-13	82-385-382-01		Rod, P	AD-6300	1
2-14	82-399-025-01		AC switch button ass'y	AD-6400	1
2-15	82-385-383-01		Stopper rod	AD-6300	4
2-16	82-397-324-01		Holder, Circuit board	AD-6550	1
2-17	87-038-039-01		Wire binder		2
2-18	82-306-002-01		Plate, Meter	*	1
2-19	82-305-017-01		Lever, Bias		2
2-20	82-305-011-01		Button, Counter		1
2-21	82-305-222-01		Spring, Counter		1
2-22	82-305-224-01		Counter		1
2-23	82-305-201-01		Front chassis M		1
2-24	82-305-019-01		Button, Memory		1
2-25	82-305-013-01		REC/MUTE button		1
2-26	82-305-015-01		Button, Selector switch		3
2-27	82-305-215-01		Push-rod, Meter		1
2-28	82-397-319-01		Slide rod, Auto A	AD-6550	1
2-29	82-305-216-01		Push-rod, Selector		2
2-30	82-397-334-01		Auxiliary plate	AD-6550	1
2-31	82-305-219-01		Holder, Peak circuit board		2
2-32	82-386-629-01		Shield plate, Jack	AD-1250	1
2-33	87-085-102-01		Nylon rivet		U:6/ E,K:8
2-34	87-085-101-01		Cord bushing (U model only)		1
2-35a	87-034-877-01		AC power cord (E model only)		1
2-35b	87-034-872-01		AC power cord (K model only)		1
2-35c	87-034-874-01		AC power cord (U model only)	*	1
2-36a	82-306-016-01		Jack plate (E model only)	*	1
2-36b	82-306-017-01		Jack plate (K model only)	*	1
2-36c	82-306-018-01		Jack plate (U model only)	*	1
2-37	82-397-649-01		Earth lug	AD-6550	1
2-38	82-033-008-01		Earth terminal		1
2-39	82-397-317-01		Slide rod, REC	AD-6550	1
2-40	87-085-094-01		Holder, AC power cord (E, K model only)		1
2-41	87-085-095-01		Holder B, AC power cord (E, K model only)		1
2-42	82-397-244-01		Holder, AC power cord	AD-6550	1
2-43	82-306-010-01		Name plate, Spec. (U model only)	*	1
2-44	82-306-025-01		Button, Synchro switch	*	1
2-45	87-056-016-01		Tag, Main voltage (K model only)		1
2-46	87-056-008-01		Label, AC power cord (K model only)		1

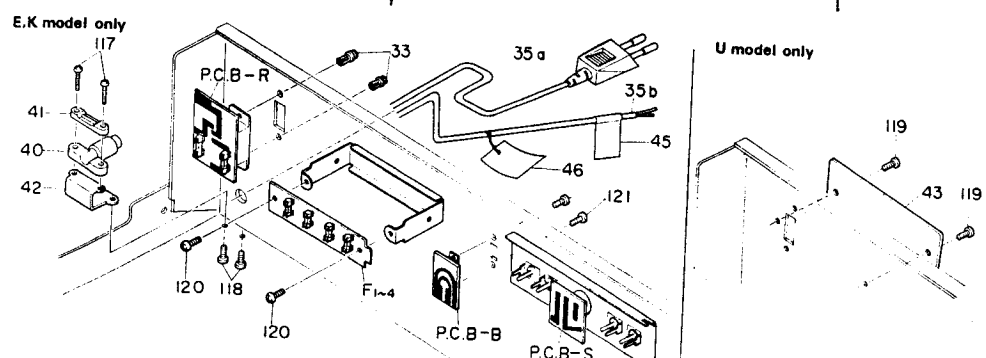

EXPLODED VIEW-3

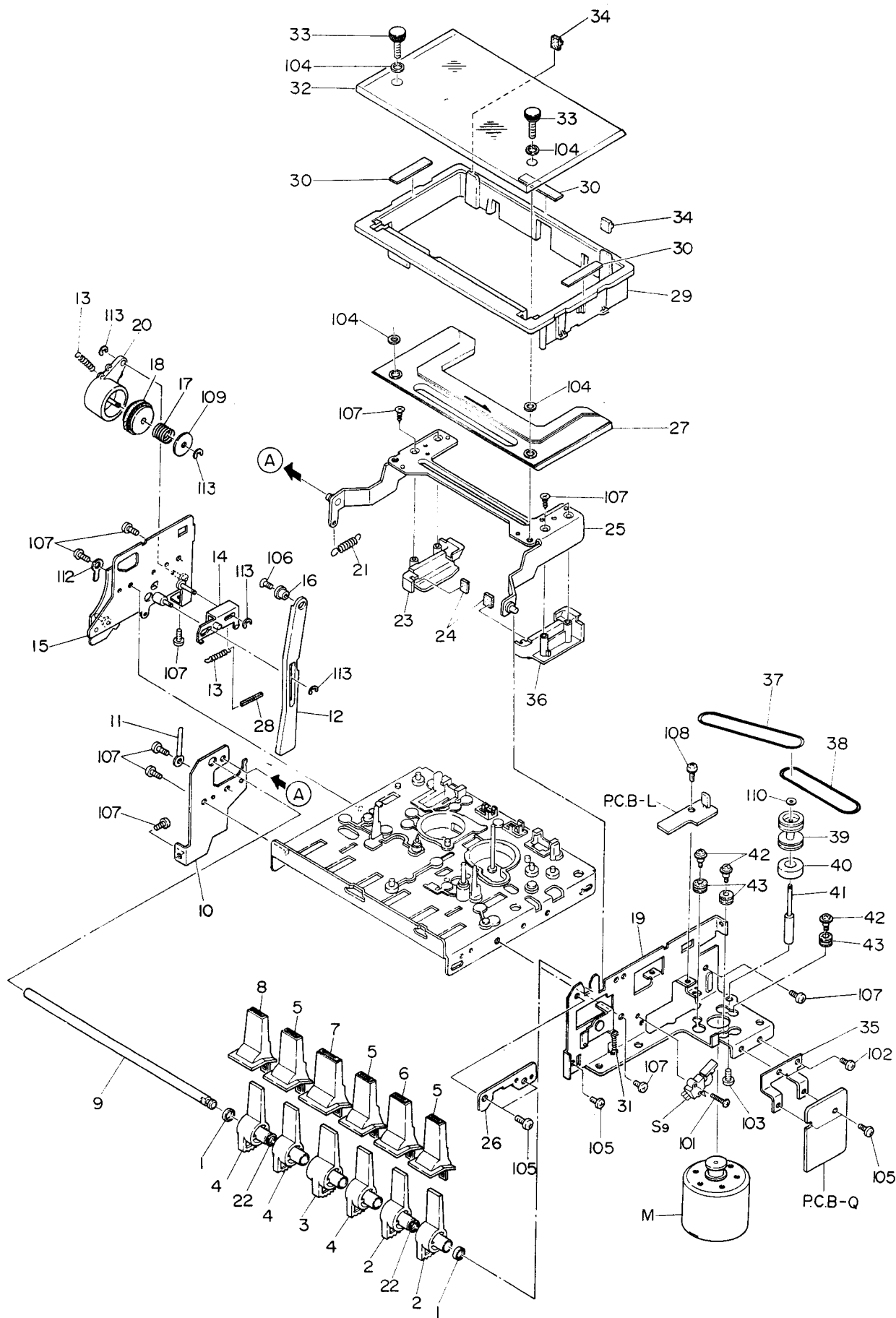

Ref. No.	Part No.	Part No. Changed to	Description	Common Model	Q'ty
3-1	82-397-279-01		Collar, Push-key	AD-6550	2
3-2	82-397-276-01		Push-key lever, REW	AD-6550	2
3-3	82-397-274-01		Push-key lever, PLAY	AD-6550	1
3-4	82-397-275-01		Push-key lever, STOP	AD-6550	3
3-5	82-397-046-01		Push-key, FF	AD-6550	3
3-6	82-397-048-01		Push-key, STOP	AD-6550	1
3-7	82-397-045-01		Push-key, PLAY	AD-6550	1
3-8	82-397-047-01		Push-key, REC	AD-6550	1
3-9	82-397-278-01		Shaft, Push-key	AD-6550	1
3-10	82-397-252-01		Holder, Push-key	AD-6550	1
3-11	87-038-039-01		Wire binder		1
3-12	82-397-280-01		Lock plate, Cassette lid	AD-6550	1
3-13	82-397-301-01		Spring	AD-6550	2
3-14	82-397-261-01		Lock lever ass'y	AD-6550	3
3-15	82-399-203-01		Frame chassis L ass'y,	AD-6550	1
3-16	82-397-281-01		Frang collar, Cassette lid	AD-6550	1
3-17	82-397-302-01		Spring, Oil	AD-6550	1
3-18	82-397-271-01		Idler ass'y, Oil	AD-6550	1
3-19	82-306-202-01		Frame chassis R ass'y		1
3-20	82-397-265-01		Drum Oil ass'y	AD-6550	1
3-21	82-399-215-01		Spring, Cassette lid arm		1
3-22	87-081-574-01		Spacer, Button		1
3-23	82-397-043-01		Cassette case L	AD-6550	1
3-24	82-397-312-01		Cushion, Cassette case	AD-6550	2
3-25	82-305-217-01		Cassette case proper ass'y		1
3-26	82-397-270-01		Shaft, Stopper C	AD-6550	1
3-27	82-305-022-01		Cassette lid ass'y		1
3-28	87-063-109-01		Cushion		1
3-29	82-397-044-01		Blinder	AD-6550	1
3-30	82-397-313-01		Cushion, Blinder	AD-6550	3
3-31	82-272-424-01		Spring, Brake		1
3-32	82-305-003-01		Window, Cassette case		1
3-33	82-397-040-01		Screw 4-13	AD-6550	2
3-34	82-397-055-01		Cushion, Cassette lid	AD-6550	2
3-35	82-397-647-01		Holder, Motor circuit board	AD-6550	1
3-36	82-397-042-01		Cassette case R	AD-6550	1
3-37	82-397-325-01		Rubber belt C	AD-6550	1
3-38	82-397-314-01		Rubber belt A	AD-6550	1
3-39	82-397-228-01		Relay pulley	AD-6550	1
3-40	82-379-617-01		Ring magnet		1
3-41	82-397-247-01		Shaft ass'y, Relay	AD-6550	1
3-42	87-081-483-01		Motor screw		3
3-43	87-087-029-01		Rubber cushion		3

For Service Manuals Contact
MAURITRON TECHNICAL SERVICES
 8 Cherry Tree Rd, Chinnor
 Oxon OX9 4QY
 Tel: 01844-351694 Fax: 01844-352554
 Email: enquiries@mauritron.co.uk

EXPLODED VIEW-4

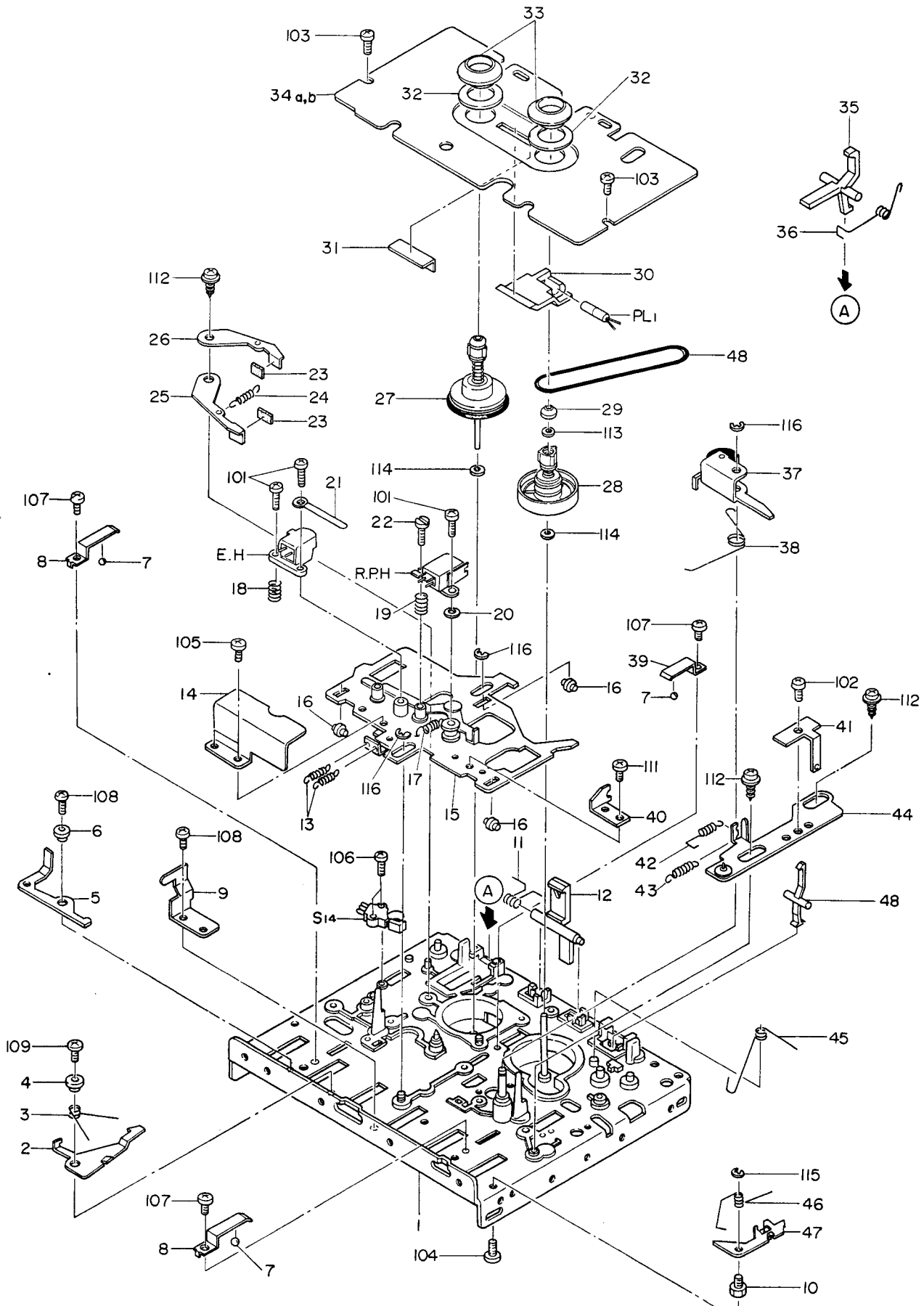

Ref. No.	Part No.	Part No. Changed to	Description	Common Model	Q'ty
4-1	82-392-202-01		Outsert chassis ass'y	AD-6550	1
4-2	82-397-320-01		Stopper, Actuating chassis	AD-6550	1
4-3	82-397-299-01		Spring, Stopper	AD-6550	1
4-4	82-397-323-01		Frange collar B	AD-6550	1
4-5	82-397-321-01		Lever, Actuating chassis	AD-6550	1
4-6	82-397-322-01		Frange collar A	AD-6550	1
4-7	82-215-341-01		Steel ball, 3/32		3
4-8	82-392-317-01		Spring, Actuating chassis B	AD-6550	2
4-9	82-397-289-01		Stopper B, Push-key shaft	AD-6550	1
4-10	82-392-211-01		Shaft, Lock plate	AD-6550	1
4-11	82-397-297-01		T spring, Cassette holder	AD-6550	1
4-12	82-397-286-01		Lever, Cassette holder	AD-6550	1
4-13	82-392-342-01		Return spring	AD-6550	2
4-14	82-397-291-01		Shield plate, Head	AD-6550	1
4-15	82-481-290-01		Actuating chassis ass'y		1
4-16	82-392-318-01		Rollar, Actuating chassis	AD-6550	3
4-17	82-392-343-01		Spring, Actuating	AD-6550	1
4-18	82-392-357-01		Spring, Erase head platform	AD-6550	1
4-19	82-392-347-01		Spring, Head	AD-6550	1
4-20	82-392-354-01		Cushion, Head	AD-6550	1
4-21	82-357-487-01		Lead holder D		1
4-22	82-439-373-01		Shaft, Rec./Pb head adjustment	TPR-300	1
4-23	82-392-350-01		Felt, Back tension	AD-6550	2
4-24	82-392-340-01		Spring, Back tension	AD-6550	1
4-25	82-392-359-01		Lever, Back tension C	AD-6550	1
4-26	82-392-360-01		Lever, Back tension D	AD-6550	1
4-27	82-397-326-01		Supply-reel platform ass'y	AD-6550	1
4-28	82-392-283-01		Take-up reel platform ass'y	AD-6550	1
4-29	82-392-352-01		Cap, Take-up reel platform	AD-6550	1
4-30	82-397-041-01		Guide, Light	AD-6550	1
4-31	82-397-345-01		Blinder, Light	AD-6550	1
4-32	82-397-290-01		Adhesive sheet, Ring	AD-6550	2
4-33	82-397-039-01		Ring, Reel platform	AD-6550	2
4-34a	82-397-030-01		Cassette plate (E, K model only)	AD-6550	1
4-34b	82-397-038-01		Cassette plate (U model only)	AD-6550	1
4-35	82-397-287-01		Rec-blocking lever	AD-6550	1
4-36	82-397-298-01		T spring, Blocking lever	AD-6550	1
4-37	82-392-363-01		Pinch roller ass'y	AD-6550	1
4-38	82-392-334-01		T spring, Pinch lever	AD-6550	1
4-39	82-392-317-01		Spring, Actuating chassis A	AD-6550	1
4-40	82-392-367-01		Plate	AD-6550	1
4-41	82-397-233-01		Auxiliary plate, PAUSE	AD-6550	1
4-42	82-392-375-01		Spring, Pause B	AD-6550	1
4-43	82-392-374-01		Spring, Pause A	AD-6550	1
4-44	82-392-280-01		Slide plate pause ass'y	AD-6550	1
4-45	82-392-333-01		T spring, Take-up	AD-6550	1
4-46	82-392-335-01		T spring, Lock plate	AD-6550	1
4-47	82-392-213-01		Lock plate	AD-6550	1
4-48	82-397-288-01		Lever, CrO ₂ selecting	AD-6550	1

For Service Manuals Contact
MAURITRON TECHNICAL SERVICES
8 Cherry Tree Rd, Chinnor
Oxon OX9 4QY
Tel: 01844-351694 Fax: 01844-352554
Email: enquiries@mauritron.co.uk

Ref. No.	Part No.	Part No. Changed to	Description	Common Model	Q'ty
5-1	82-418-318-01		REV. auxiliary lever ass'y		1
5-2	82-392-331-01		T spring, REV. auxiliary	AD-6550	1
5-3	82-392-235-01		Push-switch proper ass'y	AD-6550	1
5-4	82-392-262-01		Take-up idler ass'y	AD-6550	1
5-5	82-392-361-01		Lever, Main drive B	AD-6550	1
5-6	82-392-346-01		Spring, FF	AD-6550	1
5-7	82-392-313-01		Slide plate, FR	AD-6550	1
5-8	82-392-256-01		Shaft bearing ass'y	AD-6550	1
5-9	82-392-319-01		Belt, Main	AD-6550	1
5-10	82-392-371-01		Flywheel ass'y	AD-6550	1
5-11	82-331-107-01		Screw for thrust		1
5-12	82-392-321-01		Plate, Flywheel	AD-6550	1
5-13	82-397-240-01		Lever, MT switch	AD-6550	1
5-14	82-397-236-01		MT switch holder ass'y	AD-6550	1
5-15	82-374-248-01		Switch holder C		1
5-16	82-397-242-01		Slider, MT switch	AD-6550	1
5-17	82-372-417-01		Spring B, MT switch slider	AD-1500	1
5-18	82-397-308-01		Holder, Memory switch	AD-6550	1
5-19	82-397-269-01		Holder, Hall	AD-6550	1
5-20	82-392-337-01		Spring, Center shifter	AD-6550	1
5-21	82-397-283-01		Eject lever B	AD-6550	1
5-22	82-397-300-01		Spring, Eject lever	AD-6550	1
5-23	82-397-307-01		G cushion, Eject lever	AD-6550	1
5-24	82-397-253-01		Eject lever A ass'y	AD-6550	1
5-25	82-392-332-01		Spring, Brake	AD-6550	1
5-26	82-439-260-01		Brake shoe	TPR-300	2
5-27	82-392-320-01		Slide plate, Brake	AD-6550	1
5-28	82-397-360-01		Ring magnet A ass'y	AD-6550	1
5-29	82-392-353-01		Collar, Rewind shaft	AD-6550	1
5-30	82-392-326-01		Slide plate, REW	AD-6550	1
5-31	82-392-323-01		Slide plate, Brake S	AD-6550	1
5-32	82-397-285-01		Slide plate, Eject	AD-6550	1
5-33	82-392-330-01		T spring, FR lever	AD-6550	1
5-34	82-392-295-01		FR lever ass'y	AD-6550	1
5-35	82-392-315-01		Gear, REW	AD-6550	1
5-36	82-392-305-01		FF pulley ass'y	AD-6550	1
5-37	82-397-282-01		Slide plate, REC	AD-6550	1
5-38	82-392-345-01		Spring, REC lock	AD-6550	1
5-39	82-392-274-01		REC lock lever ass'y	AD-6550	1
5-40	82-397-284-01		Eject lever C	AD-6550	1
5-41	82-392-373-01		G cushion, FR	AD-6550	1
5-42	82-397-303-01		Spring	AD-6550	1
5-43	87-819-200-51		Vinyl tube		1
5-44	87-038-039-01		Wire binder		1
5-45	82-397-346-01		Holder, CrO ₂ switch	AD-6550	1
5-46	82-397-347-01		Lever, CrO ₂	AD-6550	1
5-47	82-397-350-01		T spring, CrO ₂	AD-6550	1

For Service Manuals Contact
MAURITRON TECHNICAL SERVICES
 8 Cherry Tree Rd, Chinnor
 Oxon OX9 4QY
 Tel: 01844-351694 Fax: 01844-352554
 Email: enquiries@maurtron.co.uk

Ref. No.	Part No.	Description	Q'ty
1-101	87-261-094-21	V + 3-6	4
1-102	87-251-170-21	U + 4-8	4
1-103	87-257-169-01	U + 4-6(Black)	4
1-104	87-231-095-21	Q + 3-8	2
1-105	87-347-093-01	UT ₁ + 3-5(Black)	2

Ref. No.	Part No.	Description	Q'ty
1-106	87-481-402-01	UT ₁ + 3-8(Black)	1
1-107	87-321-295-11	QT ₁ + 3-8	1
1-108	87-081-481-01	VTT + 3-5	4
1-109	87-257-178-11	U + 4-25(Black) (U model only)	4

Ref. No.	Part No.	Description	Q'ty
2-101	87-251-093-21	U + 3-5	8
2-102	87-213-095-21	U + 3-8	6
2-103	87-231-034-21	U + 2-5	2
2-104	87-341-095-11	UT ₁ + 3-8	2
2-105	87-341-073-01	UT ₁ + 2.6-6	3
2-106	87-480-072-01	VS + 2.6-5	4
2-107	87-480-169-01	VS + 4-6	2
2-108	87-480-093-01	VS + 3-5	2
2-109	87-081-481-01	VTT + 3-5	13
2-110	87-081-255-01	FW3-8-1	4
2-111	87-433-906-01	WTIE-4	1
2-112	87-441-006-01	STE-2.3	2
2-113	87-441-009-01	STE-3	1

Ref. No.	Part No.	Description	Q'ty
2-114	87-391-717-11	N-3	4
2-115	87-391-724-11	N-4	1
2-116	87-450-414-01	LB-4	1
2-117	87-261-101-01	V + 3-18	2
2-118	87-253-093-01	U + 3-5	2
2-119	87-257-003-01	U + 2-4(Black) (U model only)	2
2-120	87-081-481-01	VTT + 3-5 (E,K model only)	2
2-121	87-257-257-01	U + 2-4(Black) (E,K model only)	2
2-122	87-261-034-21	V + 2-5	2

Ref. No.	Part No.	Description	Q'ty
3-101	87-253-036-01	U + 2-8	2
3-102	87-253-071-01	U + 2.6-4	2
3-103	87-253-072-01	U + 2.6-5	1
3-104	87-081-861-01	PW + 4.6-7.2-0.25	4
3-105	87-253-093-11	U + 3-5	5
3-106	87-233-074-01	Q + 2.6-8	1
3-107	87-326-036-01	UT ₁ + 2-8(Black)	4

Ref. No.	Part No.	Description	Q'ty
3-108	87-081-481-01	VTT + 3-5	8
3-109	87-480-072-01	VS + 2.6-5	1
3-110	87-410-318-01	W3-13-0.8	2
3-111	87-081-489-01	PW1.7-3.5-0.25	1
3-112	87-450-414-01	LB-4	1
3-113	87-441-006-01	STE-2.3	4





















Ref. No.	Part No.	Description	Q'ty
4-101	87-253-035-01	U + 2-6	3
4-102	87-251-071-21	U + 2.6-4	1
4-103	87-253-031-01	U + 2-2	2
4-104	87-253-032-01	U + 2-3	1
4-105	87-480-072-01	VS + 2.6-5	2
4-106	87-341-036-01	UT ₁ + 2-8	2
4-107	87-081-501-01	VTT + 2.6-4	3
4-108	87-081-480-01	VTT + 2.6-5	2

Ref. No.	Part No.	Description	Q'ty
4-109	87-081-503-01	VTT + 2.6-8	1
4-110	87-410-305-01	W2-6-0.4	1
4-111	87-480-071-01	VS + 2.6-4	1
4-112	87-510-074-01	VFT ₂ + 2.6-8	3
4-113	87-081-808-01	PW1.7-3.5-0.25	1
4-114	87-081-319-01	TW2.3-8-0.2	2
4-115	87-441-005-01	STE-2	1
4-116	87-441-006-01	STE-2.3	3

Ref. No.	Part No.	Description	Q'ty
5-101	87-253-072-01	U + 2.6-5	1
5-102	87-253-093-11	U + 3-5	2
5-103	87-253-036-01	U + 2-8	6
5-104	87-351-074-01	VT ₁ + 2.6-8	2
5-105	87-510-074-01	VFT + 2.6-8	2
5-106	87-341-037-01	UT ₁ + 2-10	2
5-107	87-870-095-01	UT ₁ + 3-8	2
5-108	87-480-072-01	VS + 2.6-5	3
5-109	87-081-480-01	VTT + 2.6-5	5
5-110	87-081-523-01	QTT + 2.6-8	1

Ref. No.	Part No.	Description	Q'ty
5-111	87-510-074-01	VFT ₂ + 2.6-8	5
5-112	87-410-312-01	W3-6-0.3	1
5-113	87-410-317-01	W3-10-0.8	5
5-114	87-081-489-01	PW1.7-3.5-0.25	3
5-115	82-416-358-01	PW6-2.5-0.5	1
5-116	87-442-005-01	STP-5	1
5-117	87-081-319-01	TW2.3-8-0.2	2
5-118	87-441-006-01	STE-2.3	5
5-119	87-374-035-01	SS2-6	1
5-120	87-341-034-01	UT ₁ + 2-5	2

HARDWARE NOMENCLATURE

V:	Pan head screw		SS:	Set screw	
U:	Binding head screw		WTIE:	Crown washer	
Q:	Flat countersunk head screw		N:	Nut	
VT1:	Pan head tapping screw		STE:	E ring	
UT1:	Binding head tapping screw		STP:	Powerful stop ring	
QT1:	Flat countersunk head tapping screw		W:	Washer	
VS:	Pan head screw with spring washer		FW:	Fiber washer	
VTT:	Pan head tap-tight screw		PW:	Poly-slider washer	
VTF:	Flange and Pan head tapping screw		TW:	Tefron washer	
VTF2:	Flange and Pan head tapping screw		LB:	Lug terminal plate	

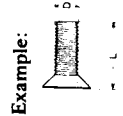
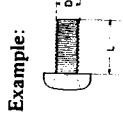

LEVEL DIAGRAM

• **PLAYBACK**

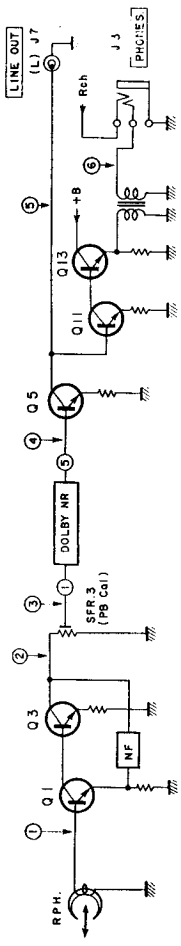
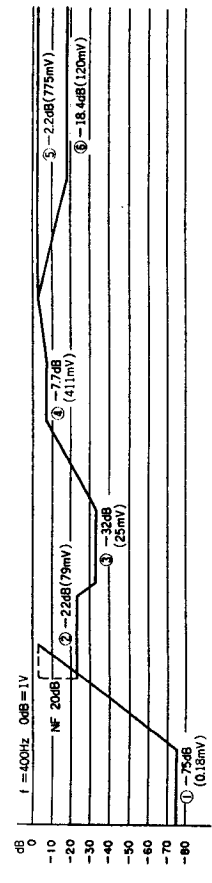

• **RECORD**

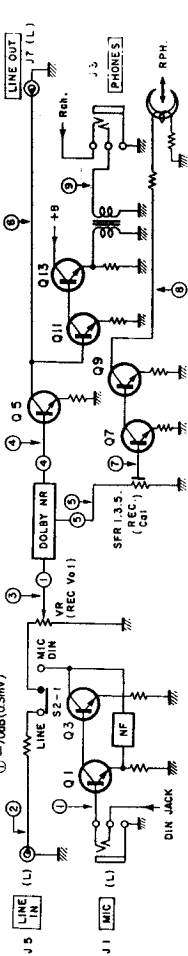
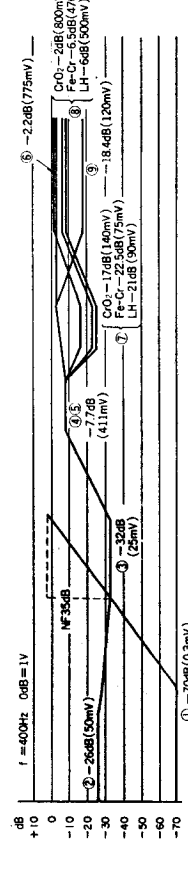

For Service Manuals Contact
MAURITRON TECHNICAL SERVICES
 8 Cherry Tree Rd, Chinnor
 Oxon OX9 4QY
 Tel: 01844-351694 Fax: 01844-352554
 Email: enquiries@mauritron.co.uk

ACCESSORIES/PACKAGE

Ref. No.	Part No.	Part No. Changed to	Description	Common Model	Q'ty
1a	82-306-854-01		Printed indiv., Packing (E, K model only)	*	1
1b	82-306-856-01		Printed indiv., Packing (U model only)	*	1
2a	82-306-859-01		Cushion L, Printed indiv. (E, K model only)	*	1
2b	82-306-861-01		Cushion L, Printed indiv. (U model only)	*	1
3a	82-306-860-01		Cushion R, Printed indiv. (E, K model only)	*	1
3b	82-306-862-01		Cushion R, Printed indiv. (U model only)	*	1
4	82-397-859-01		Pad, Cassette window		1
5	87-051-135-01		Poly-vinyl sack		1
6	87-056-564-01		Curl stopper		2
7	87-056-607-01		Poly-vinyl sack		1
8a	82-306-906-01		Instructions booklet (E model only)	*	1
8b	82-306-907-01		Instructions booklet (K model only)	*	1
8c	82-306-909-01		Instruction booklet (U model only)	*	1
9	87-051-155-01		Poly-vinyl sack (U model only)		1
10	87-051-175-01		Poly-tube A		1
11	87-056-008-01		Label, AC power cord (K model only)		1
12	87-056-009-01		Distributors list (E, K model only)		1
13	82-056-016-01		Tag, Main voltage (K model only)		1
14	87-056-034-01		Service station list (U model only)		1
15	87-056-035-01		Card, Limited warranty (U model only)		1
16	87-056-036-01		Guarantee card (U model only)		1
17	80-291-645-01		Tape cassette, DMC-130A (E, K model only)		1
18	86-925-006-01		Connection cord, CW-115KS (E, K model only)		1
19	86-944-619-01		Connection cord, CW-129KS (U model only)		2
20	87-058-023-01		Cord binder		1
21	87-058-024-01		Head cleaning pole ass'y		1

For Service Manuals Contact
MAURITRON TECHNICAL SERVICES
 8 Cherry Tree Rd, Chinnor
 Oxon OX9 4QY
 Tel: 01844-351694 Fax: 01844-352554
 Email: enquiries@mauritron.co.uk

SCHEMATIC DIAGRAM

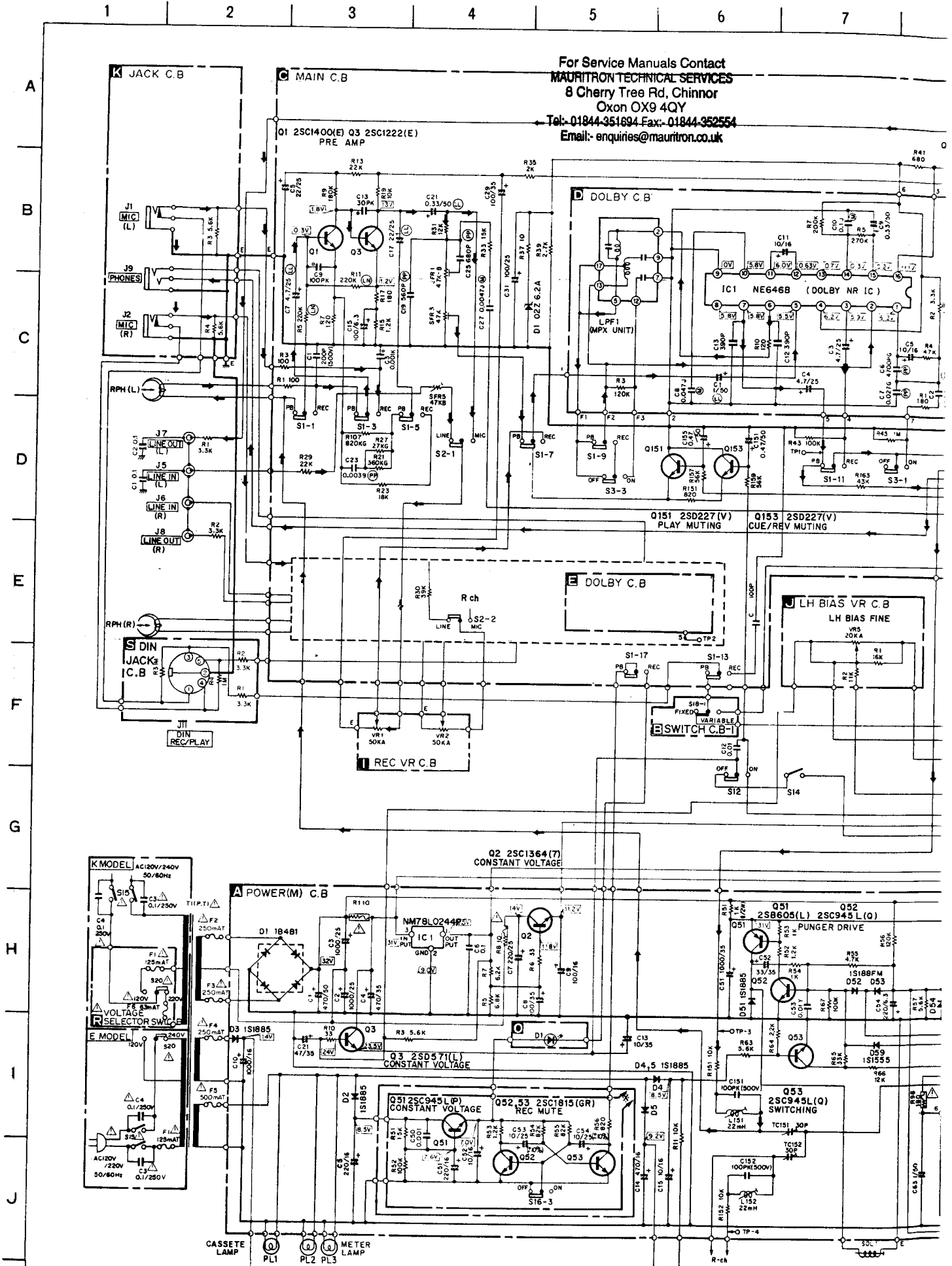

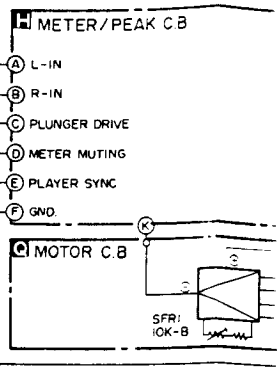
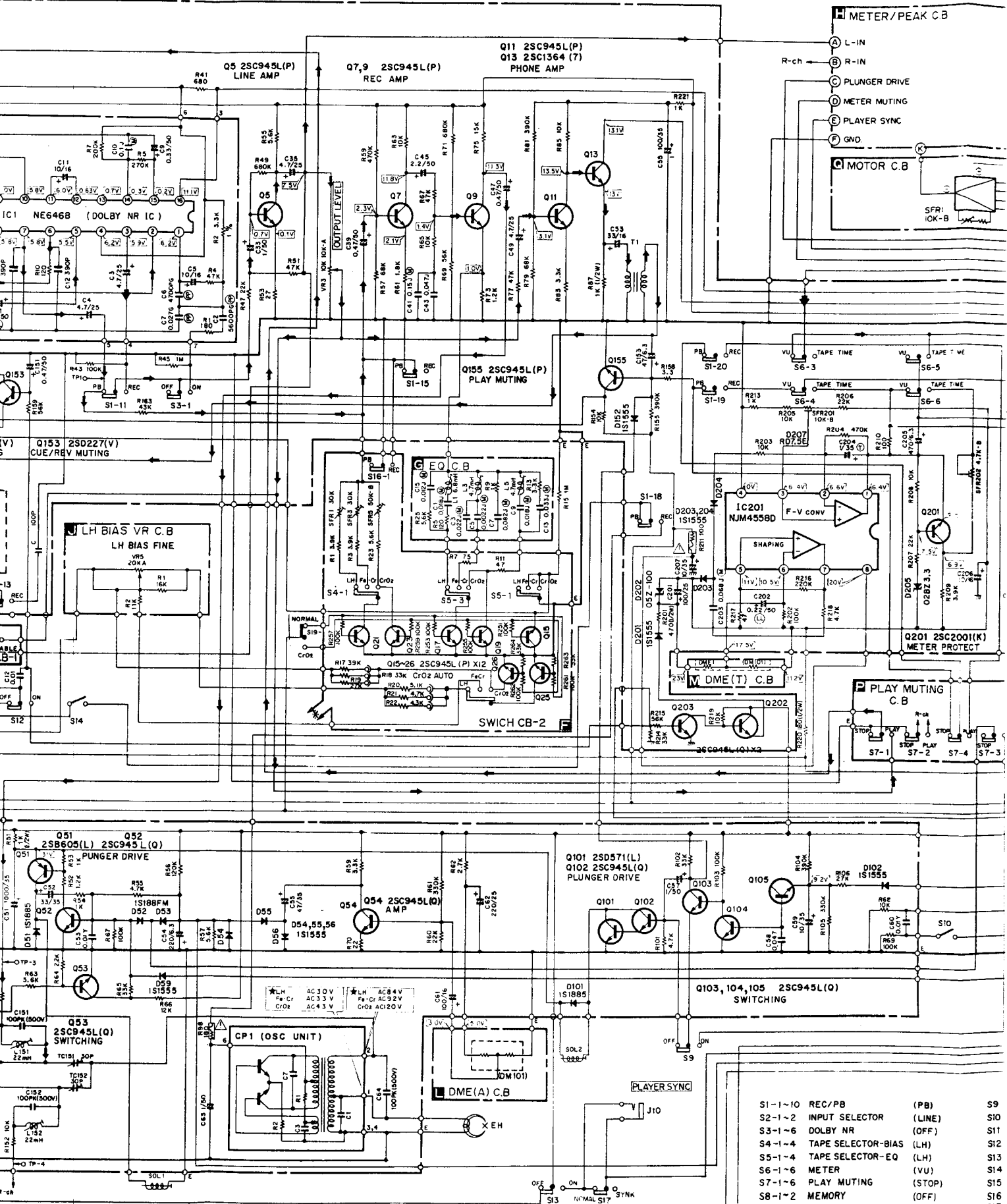

S1-1~10	REC/PB	(PB)	S9
S2-1~2	INPUT SELECTOR	(LINE)	S10
S3-1~6	DOLBY NR	(OFF)	S11
S4-1~4	TAPE SELECTOR-BIAS	(LH)	S12
S5-1~4	TAPE SELECTOR-EQ	(LH)	S13
S6-1~6	METER	(VU)	S14
S7-1~6	PLAY MUTING	(STOP)	S15
S8-1~2	MEMORY	(OFF)	S16
			S17

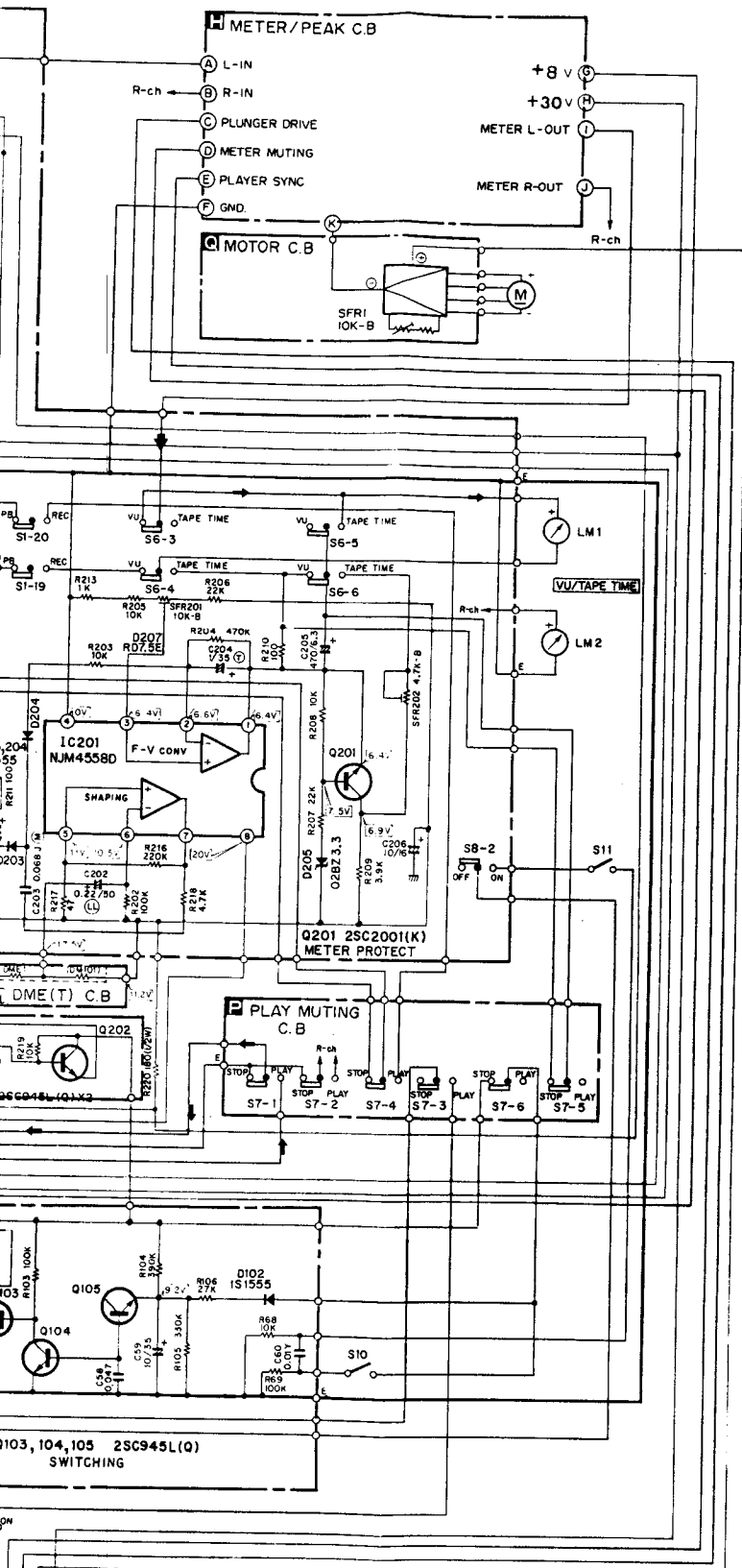

NOTES:

- 1) — B (+) power supply
- 2) ➤ Signal path
➤ Rec path
- 3) The voltage is the reference value measured with a tester (20 k-ohms/V DC) when there are no signals. But () is with recording. An asterisk (*) indicates that the value was measured with a vacuum-tube voltmeter during recording.
- 4) Resistors with no designation have a rated power of 1/4W and a tolerance of ±5%.
- 5) Capacitors with no designation have a dielectric strength of less than 50WV.
- 6) The only capacitor tolerances indicated are ±5% (J) and ±10% (K).
- 7) Ceramic capacitor symbols:
 ○— For temperature compensation (SL)
 —|— High dielectric constant system (YY)
 —|— High dielectric constant system (YW, YP, YZ)
- 8) Explanation of symbols
 (M) Mylar capacitor
 (A) Aluminum solid capacitor
 (PP) Polypropylene film capacitor
 (LL) Low-leakage capacitor
 (T) Tantalum capacitor
 (S) Styrol capacitor
 (LN) Low noise resistor
 —|— Fuse resistor
 ⚠ Safety component symbol
 This symbol is given to important parts which serve to maintain the safety of the product, and which are made to conform to special safety specifications. Therefore, when replacing a component with this symbol, make absolutely sure that you use a designated part.
- This schematic diagram is subject to change without notice in the interests of improved performance.

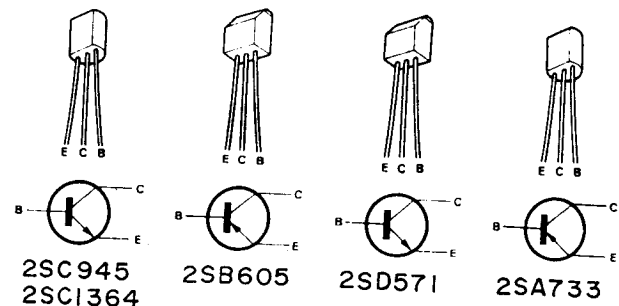

- 25C945
- 25C1364
- 25C1400
- 25D227
- 25C1815
- 25C1222
- 25C2001
- 25B605
- 25D571
- 25A733

For Service Manuals Contact
MAURITRON TECHNICAL SERVICES
 8 Cherry Tree Rd, Chinnor
 Oxon OX9 4QY
 Tel: 01844-351694 Fax: 01844-352554
 Email: enquiries@mauritron.co.uk

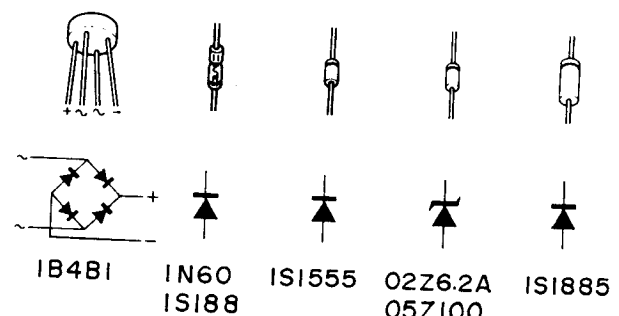

- | | |
|--------------------------------|-----------------------------|
| S1-1-10 REC/PB (PB) | S9 PAUSE (OFF) |
| S2-1-2 INPUT SELECTOR (LINE) | S10 COUNTER (OFF) |
| S3-1-6 DOLBY NR (OFF) | S11 REWIND (OFF) |
| S4-1-4 TAPE SELECTOR-BIAS (LH) | S12 CUE/REVIEW MUTING (OFF) |
| S5-1-4 TAPE SELECTOR-EQ (LH) | S13 MOTOR (OFF) |
| S6-1-6 METER (VU) | S14 METER MUTING (STOP) |
| S7-1-6 PLAY MUTING (STOP) | S15 POWER (OFF) |
| S8-1-2 MEMORY (OFF) | S16 REC MUTE (OFF) |
| | S17 PLAYER SYNC (NORMAL) |

ELECTRICAL MAIN PARTS LIST

Symbol No.	Part No.	Description
------------	----------	-------------

« POWER CIRCUIT BOARD SECTION »

PCB-A	82-306-609-01	Power circuit board
< Power section >		
IC1	87-306-671-01	IC, TA-78L024 AP
Q2,3	89-405-712-01	Transistor, 2SD571 (L)
D1	87-027-163-01	Compound diode, 1B4B1
D2,3,4,5	87-027-083-01	Diode, 1S1885
	87-032-883-01	Pin
< Resistors >		
△R1,8	87-029-017-01	10Ω 1/4W Fuse resistor
△R98	87-029-058-01	180Ω 1/4W Fuse resistor

< Bias OSC section >

L151,152	82-304-701-01	Coil, 22mH
TC151,152	85-708-604-21	Trimmer, 30pF
OSC UNIT	82-305-624-01	OSC unit

< Auto stop section >

Q51	89-206-052-01	Transistor, 2SB605 (L)
Q52,53,54	89-309-455-01	Transistor, 2SC945L (Q)
D51	87-027-083-01	Diode, 1S1885
D52,53	88-052-188-11	Diode, 1S188 (FM)
D54,55,56,59	87-027-097-01	Diode, 1S1555

< Timmer start section >

Q101	89-405-712-01	Transistor, 2SD571 (L)
Q102,103,104,105	89-309-455-01	Transistor, 2SC945L (Q)
Q155	89-309-456-01	Transistor, 2SC945L (P)
D101	87-027-083-01	Diode, 1S1885
D102	87-027-097-01	Diode, 1S1555

« SWITCH CIRCUIT BOARD-1 SECTION »

PCB-B	82-306-677-01	Switch circuit board-1
S18	87-031-460-01	Slide switch (DIN OUTPUT LEVEL)

« MAIN CIRCUIT BOARD SECTION »

PCB-C	82-306-632-31	Main circuit board
-------	---------------	--------------------

< REC/PB section >

Q1,2	89-314-005-01	Transistor, 2SC1400 (E)
Q3,4	89-312-222-01	Transistor, 2SC1222 (E)
Q5,6,7,8,9,10,11,12,15,16,17,18,19,20,21,22,23,24,25,26	89-309-456-01	Transistor, 2SC945L (P)

Q13,14	89-313-647-01	Transistor, 2SC1364 (7)
D1,2	87-027-122-01	Zener diode, 02Z-6.2A
T1,2	82-370-610-01	Matching transformer
S1	87-031-390-01	Slide switch (REC/PB)
S2,3	82-397-641-01	Push switch ass'y B (INPUT SELECTOR, DOLBY NR)
S6	82-306-608-01	Push switch (METER)
SFR1,2,3,4,5	87-021-544-01	Semi-fixed resistor, 47kΩ-B
	87-032-883-01	Pin

< Capacitors >		
C21,22	87-015-329-01	0.33μF 50V Electrolytic LL
C7,8	87-015-246-01	4.7μF 25V Electrolytic LL
C17,18	87-015-248-01	22μF 25V Electrolytic LL
C25,26	87-014-053-01	680pF PP
C19,20	87-014-051-01	560pF PP
C23,24	87-014-071-01	0.0039μF PP

< Muting section >

Q151,152,153,154	89-402-275-01	Transistor, 2SD227(V)
------------------	---------------	-----------------------

Symbol No.	Part No.	Description
------------	----------	-------------

< Remaining tape indicator section >

IC201	87-027-235-01	IC, NJM4558 (D)
Q201	89-320-011-01	Transistor, 2SC2001 (K)
Q202,203	89-309-455-01	Transistor, 2SC945L (Q)
D201,203,204	87-027-097-01	Diode, 1S1555
D202	87-027-213-01	Zener diode, 05Z-100
D205	87-027-159-01	Zener diode, 02BZ3.3
SFR201	87-021-542-01	Semi-fixed resistor, 10kΩ-B
SFR202	87-021-541-01	Semi-fixed resistor, 4.7kΩ-B

△R211	87-029-082-01	100Ω 1/4W Fuse resistor
-------	---------------	-------------------------

< Resistor >		
C202	87-015-328-01	0.22μF 50V Electrolytic LL
C204	87-019-080-01	1μF 35V Tantalum

« DOLBY CIRCUIT BOARD SECTION »

PCB-D,E	87-033-157-01	Dolby circuit board
IC1	87-027-357-01	IC, NE646B
LPF1	87-030-060-01	Low-pass filter
	87-032-640-01	Pin, 10P

< Resistor >		
R2	82-372-652-01	3.3kΩ 1/4W ±1%

< Capacitors >		
C1	87-015-241-01	1μF 50V Electrolytic LL
C6	82-317-643-01	0.0047μF ±2% PP
C2	82-371-642-01	0.0056μF ±2% PP
C7	82-371-641-01	0.027μF ±2% PP

« SWITCH CIRCUIT BOARD-2 SECTION »

PCB-F	82-306-633-31	Switch circuit board-2
Q52,53	89-318-155-01	Transistor, 2SC1815 (GR)
Q51	89-309-456-01	Transistor, 2SC945L (P)
VR3,4	82-302-622-01	Volume, 10kΩ-A (OUTPUT LEVEL)
S4,5	82-304-628-01	Lever switch (BIAS, EQ)
S16	82-302-627-01	Push switch (REC MUTE)
SFR1,2,3,4	87-021-574-01	Semi-fixed resistor, 30kΩ-B
SFR5,6	87-021-569-01	Semi-fixed resistor, 50kΩ-B

< Capacitor >		
C53,54	82-302-616-01	10μF 25V Electrolytic

« EQUALIZER CIRCUIT BOARD SECTION »

PCB-G	82-306-369-11	Equalizer circuit board
L1,2	82-306-642-01	Inductor coil, 6.8mH
L3,4,5,6	82-306-641-01	Inductor coil, 4.7mH

« METER/PEAK CIRCUIT BOARD SECTION »

PCB-H	82-306-679-11	Meter/Peak circuit board
IC1	87-027-380-01	IC, LB-1405 S
IC2	87-027-261-01	IC, LB-1405
IC11,12	87-027-298-01	IC, TC4001 BP (NOR)
IC13	87-027-299-01	IC, C-TC4030P (OR)
IC14	87-027-300-01	IC, LM555 (TIMER)
Q1,2	89-309-456-71	Transistor, 2SC945L (KP)
Q3,4,5,6,7,15,16,17,18	89-107-335-61	Transistor, 2SA733K (P)
Q11,12,13,14,19,21,72	89-309-456-01	Transistor, 2SC945L (P)
Q71	89-405-712-01	Transistor, 2SD571 (L)
D1,2,3,4,5,6	88-051-060-01	Diode, 1N60
D11,12,13,14,71	87-027-097-01	Diode, 1S1555
D15	87-027-159-01	Zener diode, 02BZ3.3
SFR1,2	87-021-533-01	Semi-fixed resistor, 1kΩ-B
SFR3	87-021-478-01	Semi-fixed resistor, 10kΩ-B

Symbc

VR1,2
 « LH B
 PCB-J
 VR5
 « FRO
 PCB-K
 J1,2,3
 « DME
 PCB-L
 DME1
 « DME
 PCB-M
 DME1
 « LED
 PCB-N
 D1
 « LED
 PCB-O
 D1
 « PLA
 PCB-P
 S7
 PIN-3
 « VOL
 CIRC
 △ PCB-R
 △ S20
 « DIN
 PCB-S
 J5,6,7,8,
 « MISC
 △ T1
 △ T1
 RPH
 EH
 LM1
 LM2
 M-PCB-C
 CP1
 PL1
 SOL1,2
 J5,6,7,8
 J10
 S8,17
 S9,11,12
 S10
 S14
 △ S15
 S19
 △ S20

Description

> M4558 (D)
 diode, 2SC2001 (K)
 diode, 2SC945L (Q)
 1S1555

diode, 05Z-100
 diode, 02BZ3.3
 fixed resistor, 10kΩ-B
 fixed resistor, 4.7kΩ-B

> Fuse resistor
 1/4W

capacitors >
 50V Electrolytic LL
 35V Tantalum

SECTION >
 circuit board
 S46B
 ss filter

tor >
 1/4W ±1%

capacitors >
 50V Electrolytic LL
 F ±2% PP
 F ±2% PP
 ±2% PP

SECTION >
 circuit board-2
 or, 2SC1815 (GR)
 or, 2SC945L (P)
 10kΩ-A
 T LEVEL)
 itch (BIAS, EQ)
 itch (REC MUTE)
 d resistor, 30kΩ-B
 d resistor, 50kΩ-B

tor >
 25V Electrolytic

SECTION >
 circuit board
 coil, 6.8mH
 coil, 4.7mH

SECTION >
 k circuit board
 05 S
 05
 1 BP (NOR)
 030P (OR)
 (TIMER)
 2SC945L (KP)
 2SA733K (P)
 2SC945L (P)
 2SD571 (L)
 00
 555
 02BZ3.3
 resistor, 1kΩ-B
 resistor, 10kΩ-B

SECTION >

Symbol No.	Part No.	Description
VR1,2	87-021-523-01	Volume, 50kΩ-A (RECORD LEVEL)
« LH BIAS VOLUME CIRCUIT BOARD SECTION »		
PCB-J	82-306-638-11	LH bias volume circuit board
VR5	82-305-632-01	Volume, 20kΩ-A (LH BIAS FINE)
« FRONT JACK CIRCUIT BOARD SECTION »		
PCB-K	82-306-635-01	Front jack circuit board
J1,2,3	82-397-639-01	Jack ass'y (MIC, PHONES)
« DME (A) CIRCUIT BOARD SECTION »		
PCB-L	82-306-625-01	DME (A) circuit board
DME1	82-397-642-01	DM-101
« DME (T) CIRCUIT BOARD SECTION »		
PCB-M	82-306-626-01	DME (T) circuit board
DME1	82-397-642-01	DM-101
« LED (P) CIRCUIT BOARD SECTION »		
PCB-N	82-306-680-01	LED (P) circuit board
D1	87-027-260-01	Light emitting diode, MULTI (PEAK)
« LED (R) CIRCUIT BOARD SECTION »		
PCB-O	82-306-681-01	LED (R) circuit board
D1	87-027-218-01	Light emitting diode (RED)
« PLAY MUTING CIRCUIT BOARD SECTION »		
PCB-P	82-306-624-01	Play muting circuit board
S7	87-031-239-01	Slide switch (PLAY MUTING)
PIN-3	87-032-764-01	Pin, 14P.
« VOLTAGE SELECTOR CIRCUIT BOARD SECTION » = K MODEL ONLY		
PCB-R	82-397-650-01	Voltage selector circuit board
S20	87-031-364-01	Slide switch (VOLTAGE SELECTOR)
« DIN JACK CIRCUIT BOARD SECTION »		
PCB-S	82-306-676-01	Din jack circuit board
J5,6,7,8,11	82-306-682-01	Jack ass'y (LINE IN/REC. LINE OUT/PLAY. DIN)
« MISCELLANEOUS »		
T1	82-305-629-01	Power transformer (E model only)
T1	82-305-630-01	Power transformer (K model only)
RPH	87-046-157-01	REC/PB head
EH	87-046-156-01	Erase head
LM1	82-306-605-01	Level meter A (LEFT LEVEL)
LM2	82-306-606-01	Level meter B (RIGHT LEVEL)
M-PCB-Q	82-397-643-11	Motor ass'y (DC FG)
CP1	87-027-036-01	Compound capacitor
PL1	82-397-646-01	Pilot lamp, 8V 50mA (CASSETTE)
SOL1,2	82-397-633-01	Solenoid (AUTO STOP, TIMER START)
J5,6,7,8	82-306-670-01	Jack (LINE IN/REC, LINE OUT/PLAY)
J10	87-032-882-01	Jack 2.5φ (PLAYER SYNC)
S8,17	87-031-360-01	Push switch (MEMORY, PLAYER SYNC)
S9,11,12,13	87-031-418-01	Micro switch (PAUSE, REWIND, CUE/REVIEW, MOTOR)
S10	82-305-224-01	Counter (COUNTER)
S14	87-031-419-01	Micro switch (BIAS MITING)
S15	87-031-408-01	Push switch (POWER)
S19	87-031-377-01	Micro switch (CrO ₂ AUTO)
S20	87-031-364-01	Slide switch (VOLTAGE SELECTOR) (E model only)

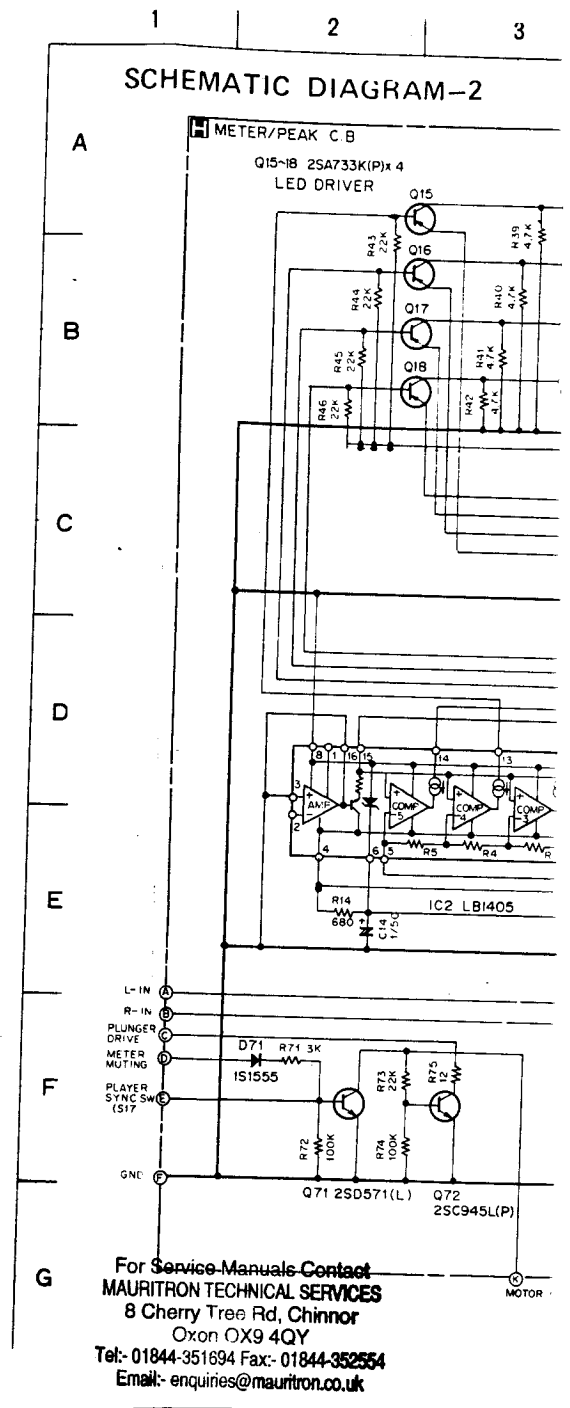

Symbol No.	Part No.	Description
F1	87-035-114-01	Fuse, "T" only)
F1	87-035-186-01	Fuse, "T" only)
F2,3,4	87-098-007-01	Fuse label, Fuse, "T" only)
F2,3,4	87-035-144-01	Fuse, "T" only)
F2,3,4	87-035-145-01	Fuse, "T" only)
F5	87-098-010-01	Fuse label, Fuse, "T" only)
F5	87-035-075-01	Fuse, "T" only)
F5	87-035-134-01	Fuse, "T" only)
F6	87-098-013-01	Fuse label, Fuse, "T" only)
F6	87-035-184-01	Fuse, "T" only)
F6	87-098-004-01	Fuse label, Fuse, "T" only)

SCHEMATIC DIAGRAM-2

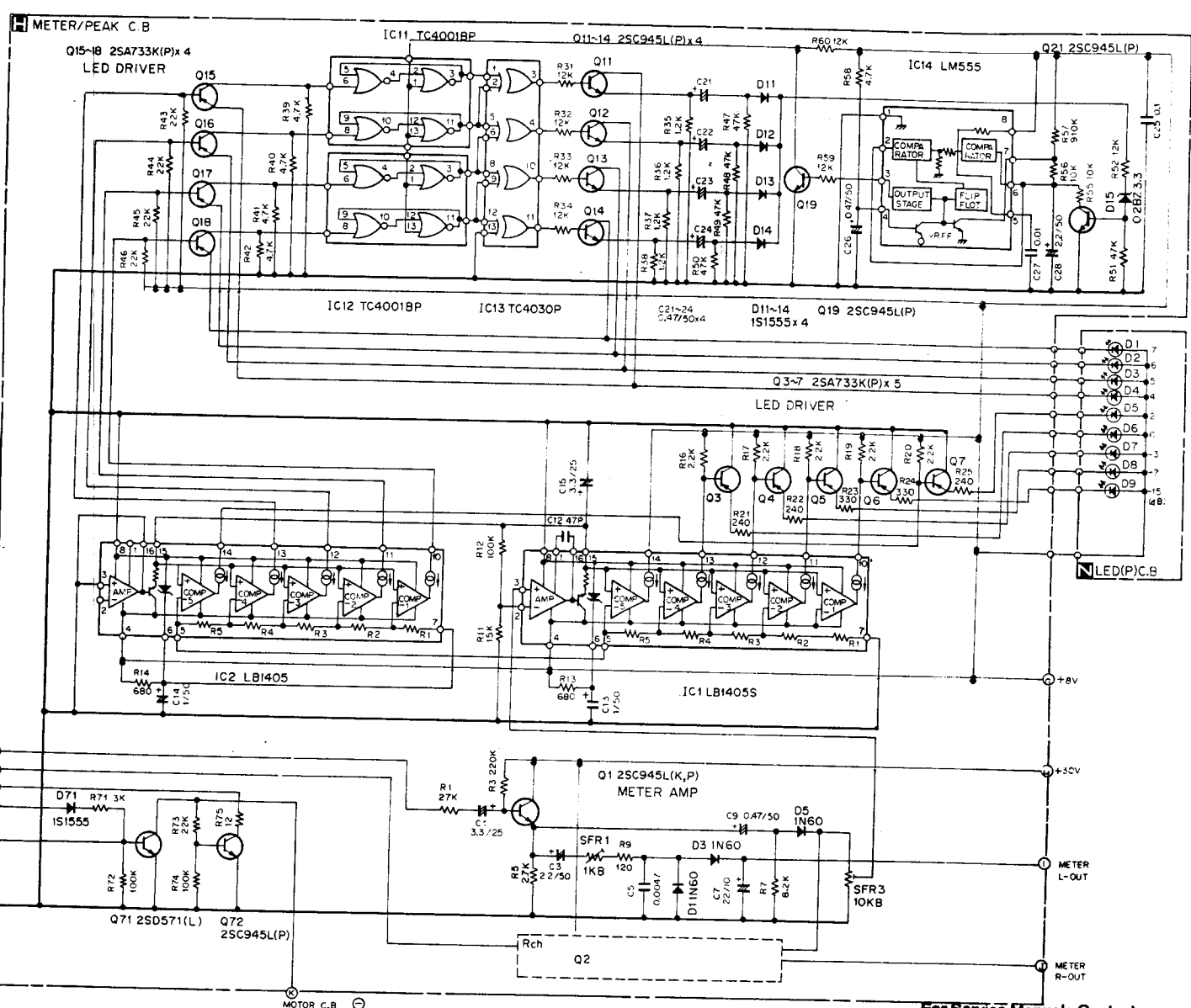

For Service Manuals Contact
MAURITRON TECHNICAL SERVICES
 8 Cherry Tree Rd, Chinnor
 Oxon OX9 4QY
 Tel:-01844-351694 Fax:- 01844-352554
 Email:-enquiries@mauritron.co.uk

Symbol No.	Part No.	Description
3,4	87-035-114-01	Fuse, "T" 125 mA (E model only)
	87-035-186-01	Fuse, "T" 125 mA (K model only)
	87-098-007-01	Fuse label, "T" 125 mA
3,4	87-035-144-01	Fuse, "T" 250 mA (E model only)
	87-035-145-01	Fuse, "T" 250 mA (K model only)
	87-098-010-01	Fuse label, "T" 250 mA
	87-035-075-01	Fuse, "T" 500 mA (E model only)
	87-035-134-01	Fuse, "T" 500 mA (K model only)
	87-098-013-01	Fuse label, "T" 500 mA
	87-035-184-01	Fuse, "T" 63 mA (K model only)
	87-098-004-01	Fuse label, "T" 63 mA

Symbol No.	Part No.	Description
CON-1	82-306-689-01	Connector ass'y, 12P (A)
CON-1'	82-306-690-01	Connector ass'y, 12P (B)
CON-2	82-306-691-01	Connector ass'y, 12P (A)
CON-2'	82-306-692-01	Connector ass'y, 12P (B)
CON-3	82-306-668-11	Connector ass'y, 14P
	87-034-877-01	AC power cord (E model only)
	87-034-872-01	AC power cord (K model only)
	<Capacitors>	
	84-190-622-01	Line capacitor 0.1μF 250V

⚠ Safety component symbol
 This symbol is given to important parts which serve to maintain the safety of the product, and which are made to conform to special safety specifications. Therefore, when replacing a component with this symbol, make absolutely sure that you use a designated part.

WIRING-1

1 | 2 | 3 | 4 | 5 | 6

A
B
C
D
E
F
G
H
I
J

For Service Manuals Contact
MAURITRON TECHNICAL SERVICES
 8 Cherry Tree Rd, Chinnor
 Oxon OX9 4QY
 Tel:- 01844-351694 Fax:- 01844-352554
 Email:- enquiries@mauriton.co.uk

REC VR C.B

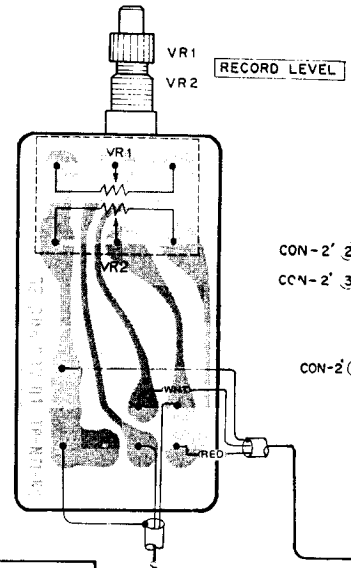

5 Input Sensitivity Adjustment

Settings:

- Recording mode
- Input signal: 1 kHz, -10 dB
- Adjustment location: SFR5

Method:

Adjust SFR5 so that the Line out level is 0.775 V and the same output for both the left and right channel when the RECORD LEVEL variable.

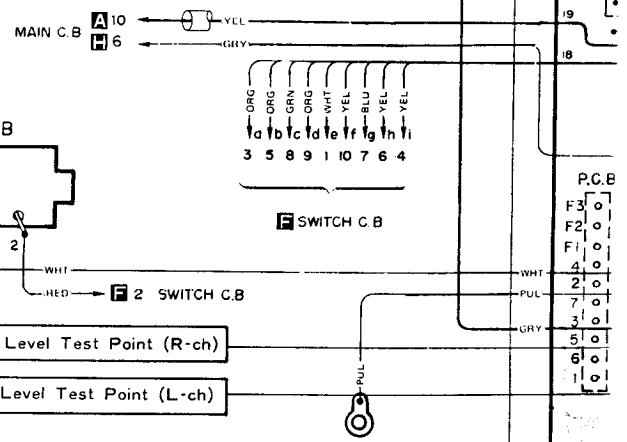

3 Dolby Level Adjustment

Settings:

- Test tape: TTA-161
- TAPE SELECTOR switch: LH
- Test point: TP1 (L-ch), TP2 (R-ch)
- Adjustment locations: SFR3 (L-ch), SFR4 (R-ch)

Method:

Play back the test tape and adjust so that the output is 580 mV.

Rating:

Line output 1.05 V

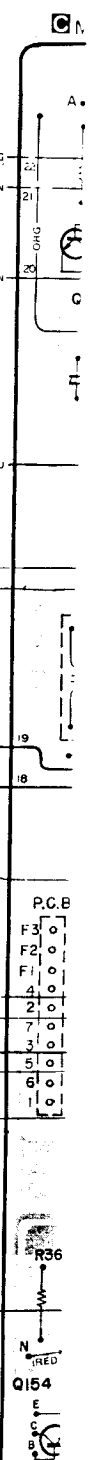

14 Tape Time 0 Point Adjustment

Settings:

- TAPE SELECTOR switch: LH
- METER: TAPE TIME
- Test tape: BASF LH SMC-60
- Adjustment location: SFR201

Method:

Run the test tape for 90 seconds beginning at the magnetic substance of the tape. (from the RPH passing point) Then turn the tape over and adjust the so that the indicator points "0" within 30 ~ 60 seconds from that point.

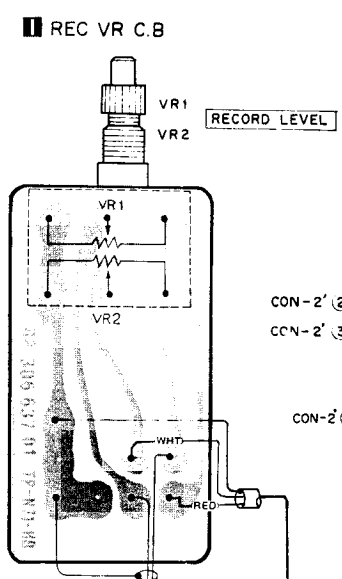

5 Input Sensitivity Adjustment

Settings:

- Recording mode
- Input signal: 1 kHz, -10 dB
- Adjustment location: SFR5

Method:

Adjust SFR5 so that the Line out level is 0.775 V and the same output for both the left and right channel when the RECORD LEVEL variable.

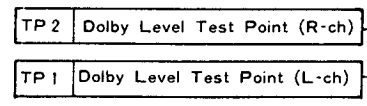
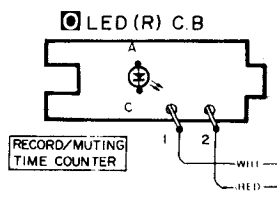

3 Dolby Level Adjustment

Settings:

- Test tape: TTA-161
- TAPE SELECTOR switch: LH
- Test point: TP1 (L-ch), TP2 (R-ch)
- Adjustment locations: SFR3 (L-ch), SFR4 (R-ch)

Method:

Play back the test tape and adjust so that the output is 580 mV.

Rating:

Line output 1.05 V

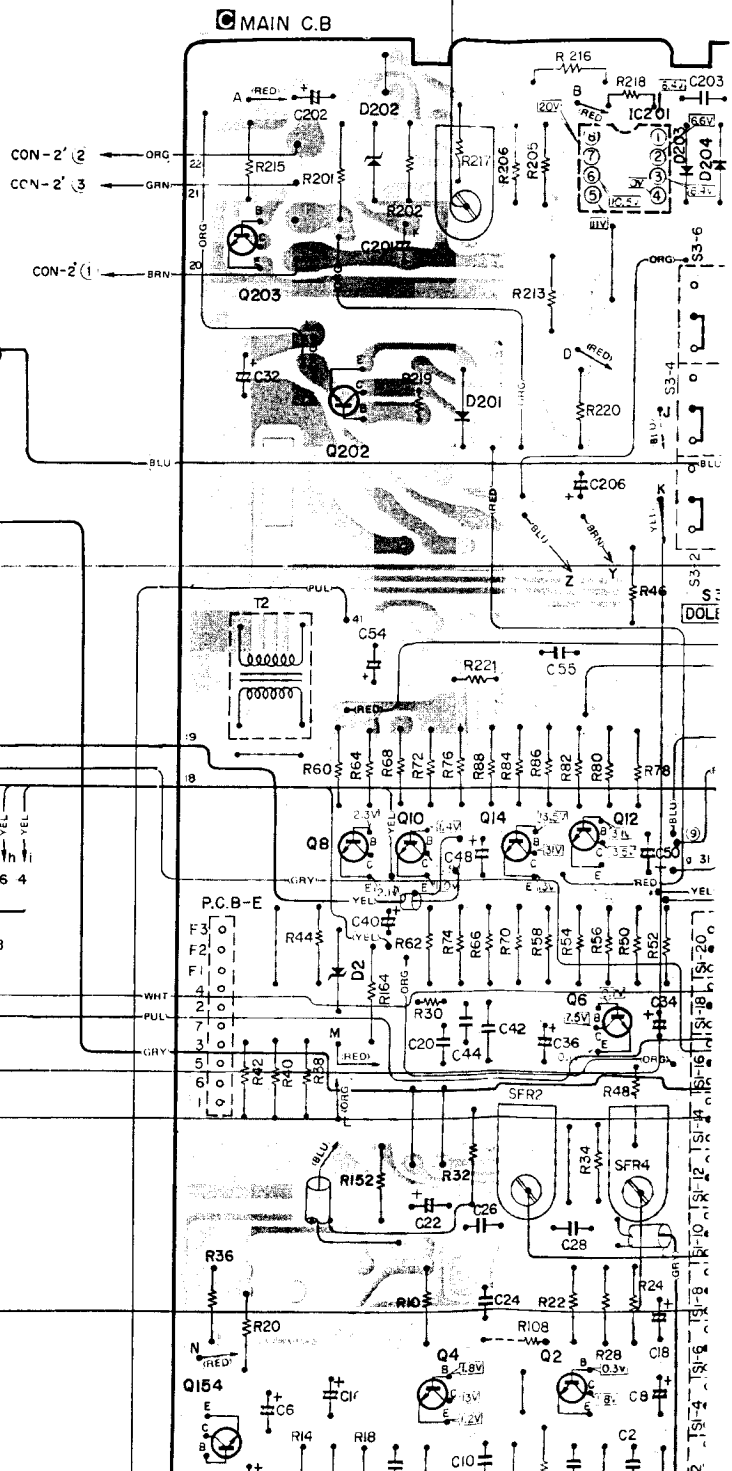

14 Tape Time 0 Point Adjustment

Settings:

- TAPE SELECTOR switch: LH
- METER: TAPE TIME
- Test tape: BASF LH SMC-60
- Adjustment location: SFR201

Method:

Run the test tape for 90 seconds beginning at the magnetic substance of the tape. (from the RPH passing point) Then turn the tape over and adjust the so that the indicator points "0" within 30 ~ 60 seconds from that point.

For Service Manuals Contact
MAURITRON TECHNICAL SERVICES
 8 Cherry Tree Rd, Chinnor
 Oxon OX9 4QY
 Tel: 01844-351694 Fax: 01844-352554
 Email: enquiries@mauritron.co.uk

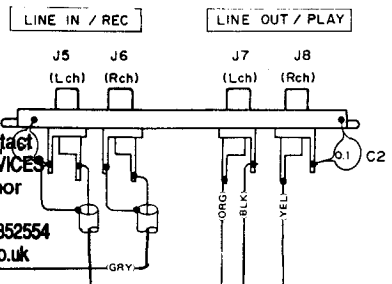

15 Tape Time Full Sc.

Settings:

- TAPE SELECTOR switch: LH
- METER: TAPE TIME
- Test tape: AIWA F.
- Adjustment location: SFR202

Method:

Adjust SFR202 so points to "Full Sc." to wind the test tape.

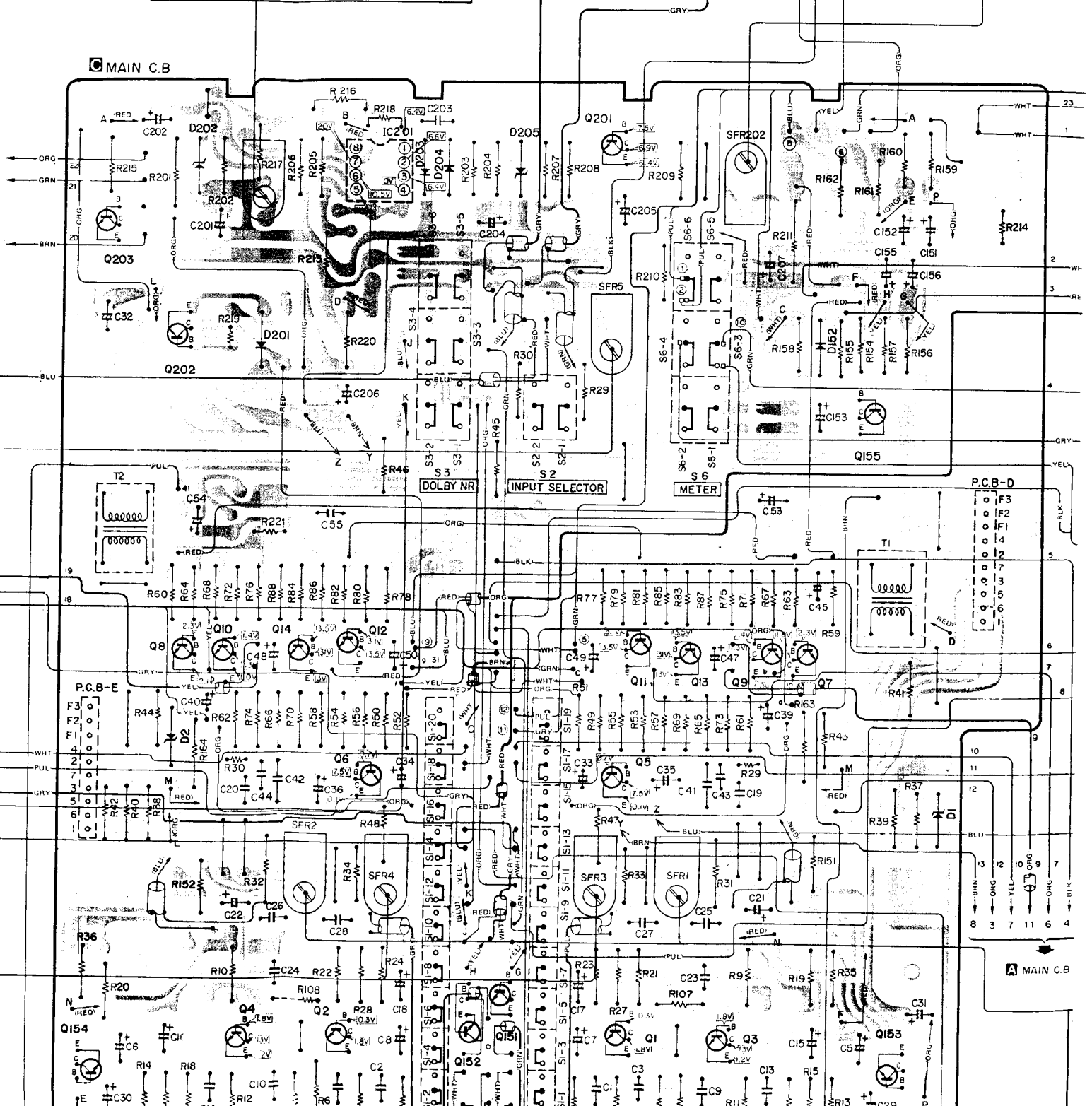

E OUT / PLAY

15 Tape Time Full Scale Adjustment

Settings:

- TAPE SELECTOR switch: Fe-Cr
- METER: TAPE TIME
- Test tape: AIWA Fe-Cr C-60
- Adjustment location: SFR202

Method:

Adjust SFR202 so that the indicator points to "Full Scale" when first starting to wind the test tape.

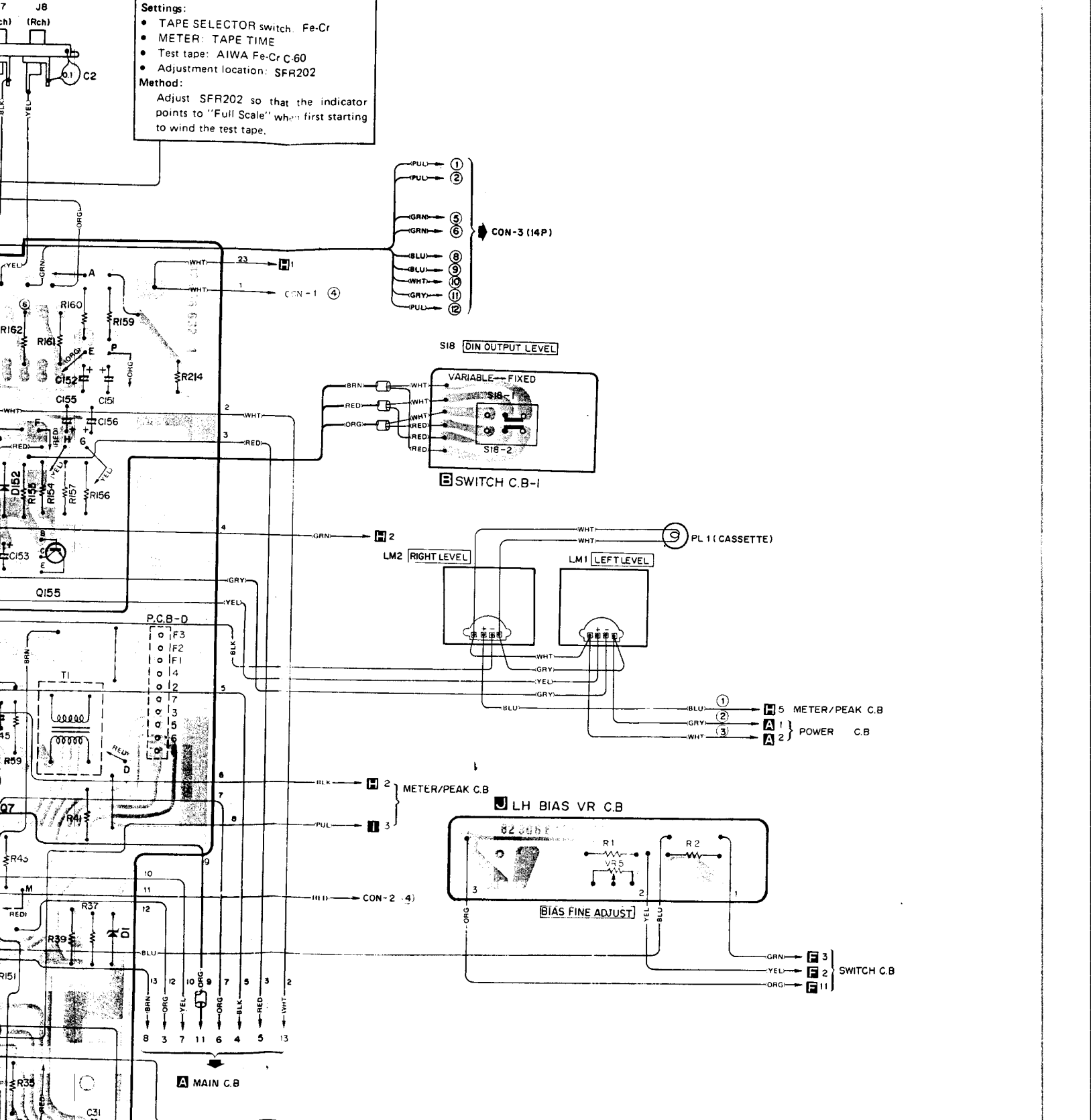

4 Playback Frequency Characteristic Adjustment

Settings:

- Test tape: TTA-117E
- TAPE SELECTOR switch: Fe-Cr
- Adjustment locations: SFR1 (L-ch), SFR2 (R-ch)

Method:

SWITCH C.B

METER/PEAK C.B
POWER C.B

METER/PEAK C.B
LH BIAS VR C.B

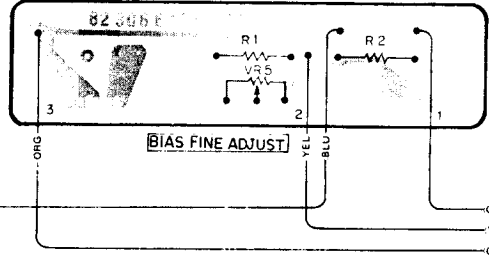

MAIN C.B

For Service Manuals Contact
MAURITRON TECHNICAL SERVICES
 8 Cherry Tree Rd, Chinnor
 Oxon OX9 4QY
 Tel: 01844-351694 Fax: 01844-352554
 Email: enquiries@maurtron.co.uk

5 Input Sensitivity Adjustment

- Settings:**
- Recording mode
 - Input signal: 1 kHz, -10 dB
 - Adjustment location: SFR5
- Method:**
- Adjust SFR5 so that the Line out level is 0.775 V and the same output for both the left and right channel when the RECORD LEVEL variable.

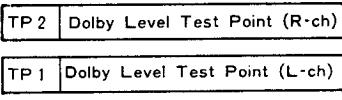
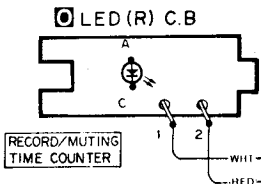
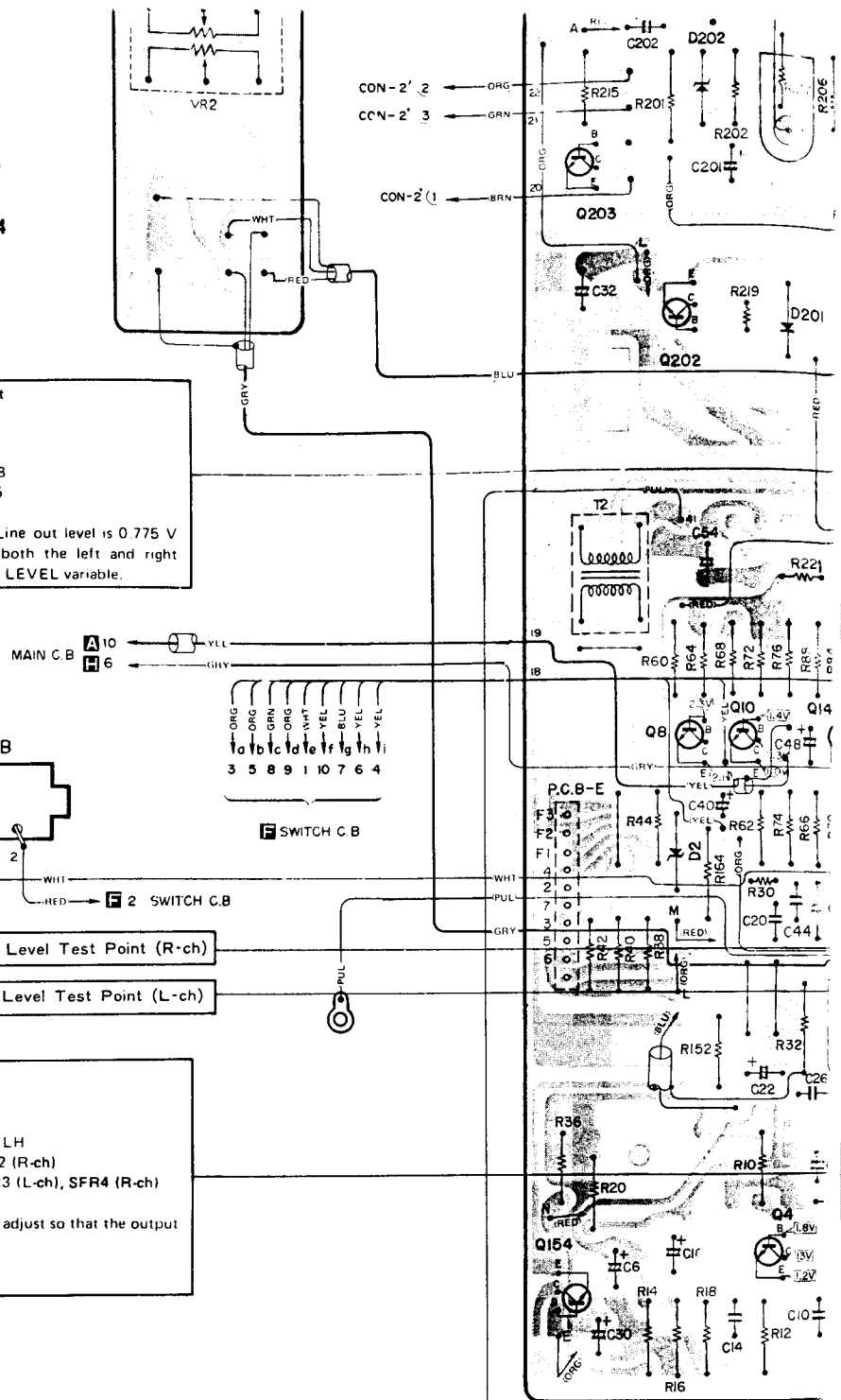

- 3 Dolby Level Adjustment**
- Settings:**
- Test tape: TTA-161
 - TAPE SELECTOR switch: LH
 - Test point: TP1 (L-ch), TP2 (R-ch)
 - Adjustment locations: SFR3 (L-ch), SFR4 (R-ch)
- Method:**
- Play back the test tape and adjust so that the output is 580 mV.
- Rating:**
- Line output 1.05 V

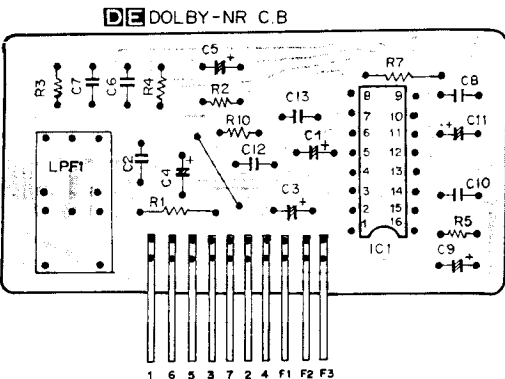

- 2 Azimuth Adjustment**
- Settings:**
- Play back mode
 - Test tape: TTA-117E
 - TAPE SELECTOR switch: Fe-Cr
 - Adjustment location: azimuth adjusting screw
- Method:**
- Play back the test tape and adjust so that the output of the 10 kHz section reaches the maximum and same phase for both the left and right channel.

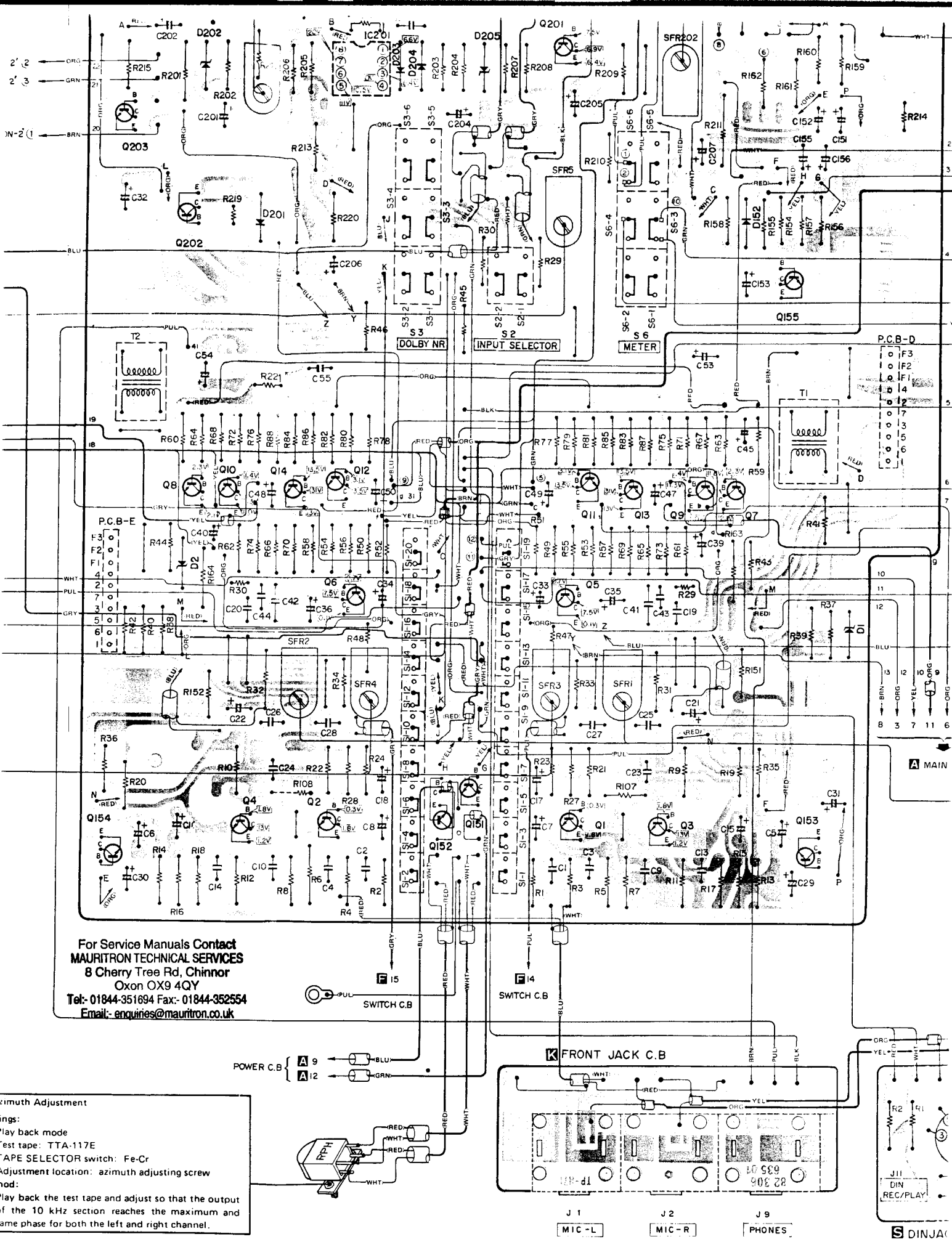

For Service Manuals Contact
MAURITRON TECHNICAL SERVICES
 8 Cherry Tree Rd, Chinnor
 Oxon OX9 4QY
 Tel: 01844-351694 Fax: 01844-352554
 Email: enquiries@mauritron.co.uk

Phonograph Azimuth Adjustment
 Settings:
 - Play back mode
 - Test tape: TTA-117E
 - TAPE SELECTOR switch: Fe-Cr
 - Adjustment location: azimuth adjusting screw
 - Method:
 - Play back the test tape and adjust so that the output of the 10 kHz section reaches the maximum and same phase for both the left and right channel.

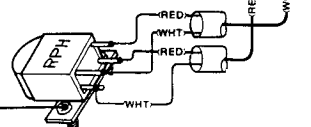

FRONT JACK C.B.

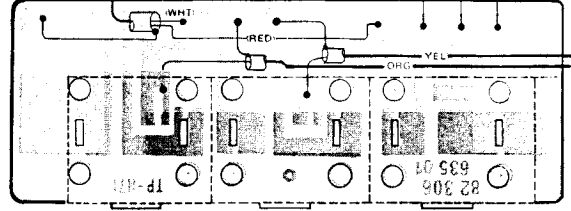

J 1 MIC-L J 2 MIC-R J 9 PHONES

S DIN/JACK

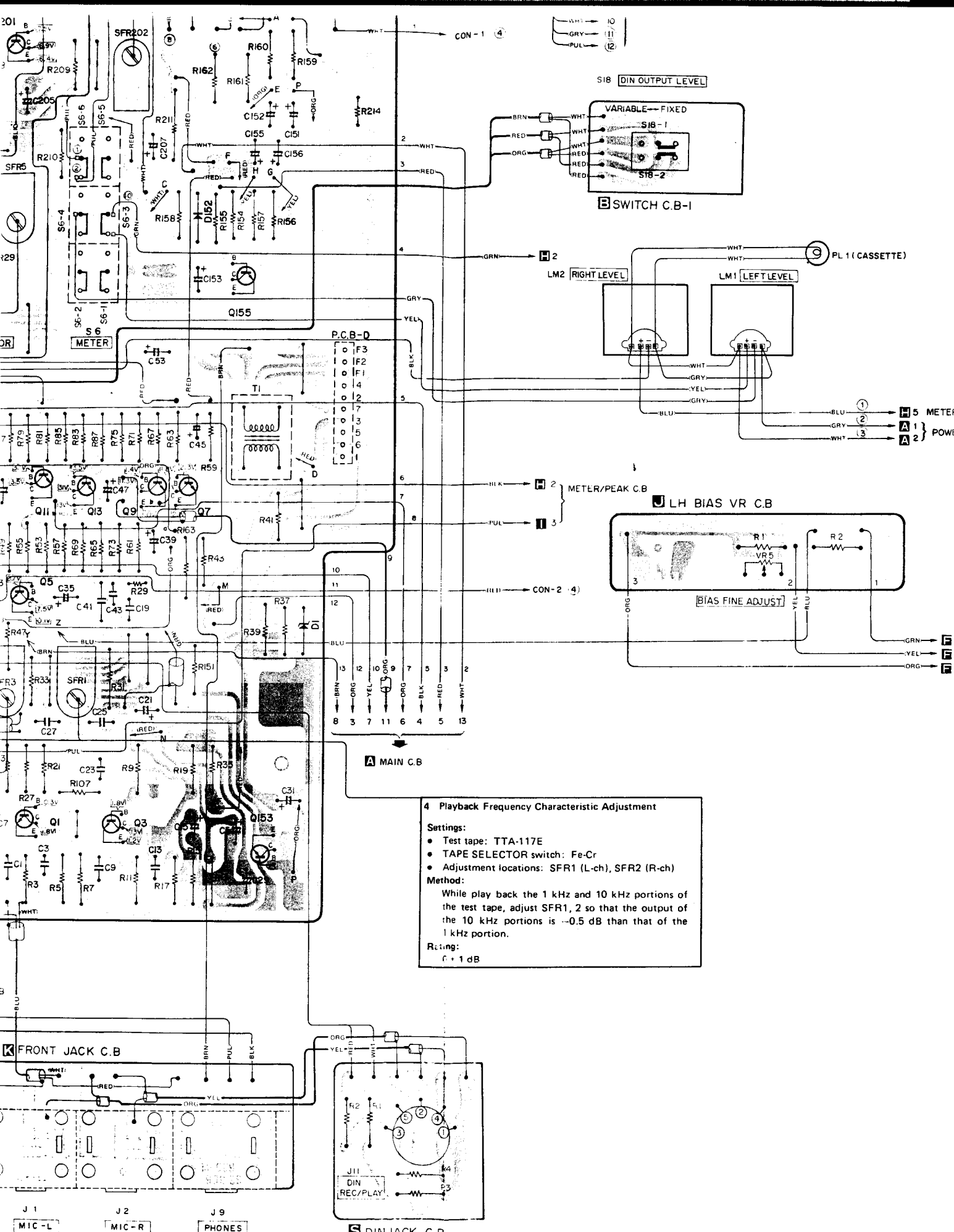

S18 DIN OUTPUT LEVEL

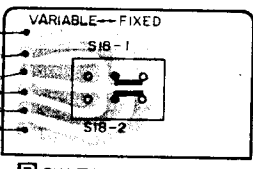

PL 1 (CASSETTE)

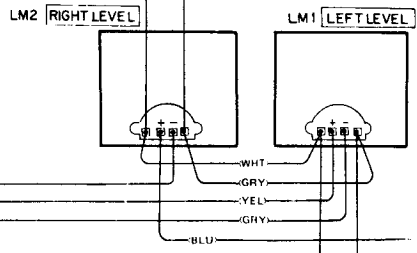

5 METER
1 }
2 } POWI
3 }

LH BIAS VR C.B

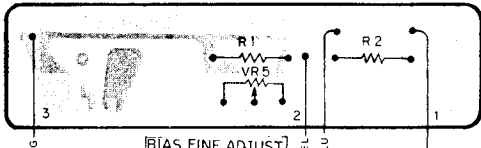

5
6
7

A MAIN C.B

4 Playback Frequency Characteristic Adjustment

Settings:

- Test tape: TTA-117E
- TAPE SELECTOR switch: Fe-Cr
- Adjustment locations: SFR1 (L-ch), SFR2 (R-ch)

Method:

While play back the 1 kHz and 10 kHz portions of the test tape, adjust SFR1, 2 so that the output of the 10 kHz portions is -0.5 dB than that of the 1 kHz portion.

Rating:

c. + 1 dB

FRONT JACK C.B

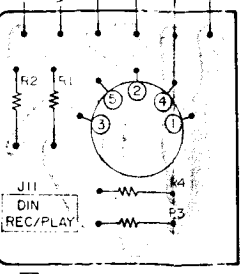
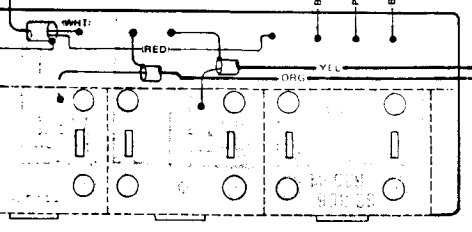

S DINJACK C.B

J 1 MIC-L
J 2 MIC-R
J 9 PHONES

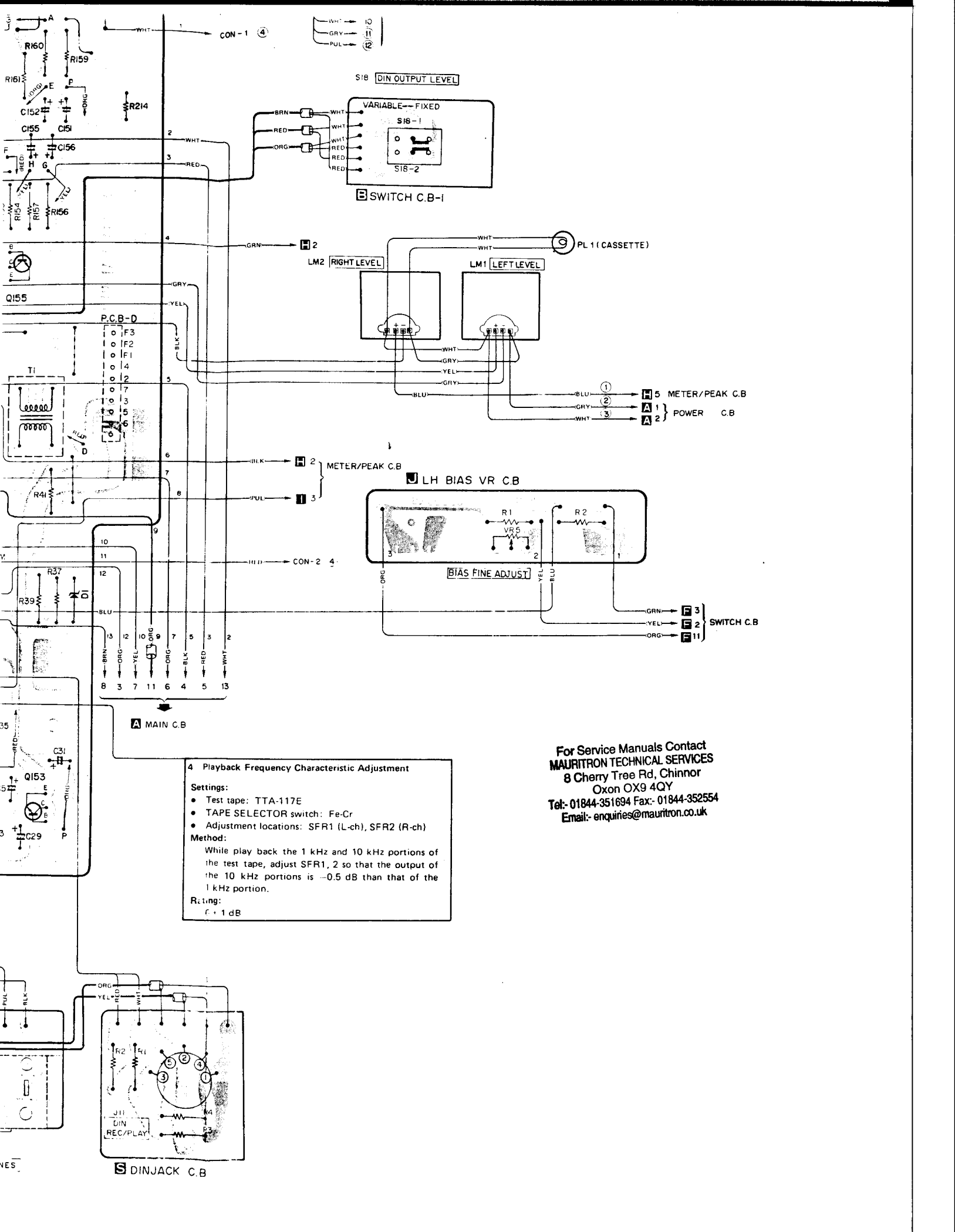

4 Playback Frequency Characteristic Adjustment

Settings:

- Test tape: TTA-117E
- TAPE SELECTOR switch: Fe-Cr
- Adjustment locations: SFR1 (L-ch), SFR2 (R-ch)

Method:

While play back the 1 kHz and 10 kHz portions of the test tape, adjust SFR1, 2 so that the output of the 10 kHz portions is -0.5 dB than that of the 1 kHz portion.

Rating:

c. + 1 dB

For Service Manuals Contact
MAURITRON TECHNICAL SERVICES
 8 Cherry Tree Rd, Chinnor
 Oxon OX9 4QY
 Tel: 01844-351694 Fax: 01844-352554
 Email: enquiries@mauritron.co.uk

WIRING-2

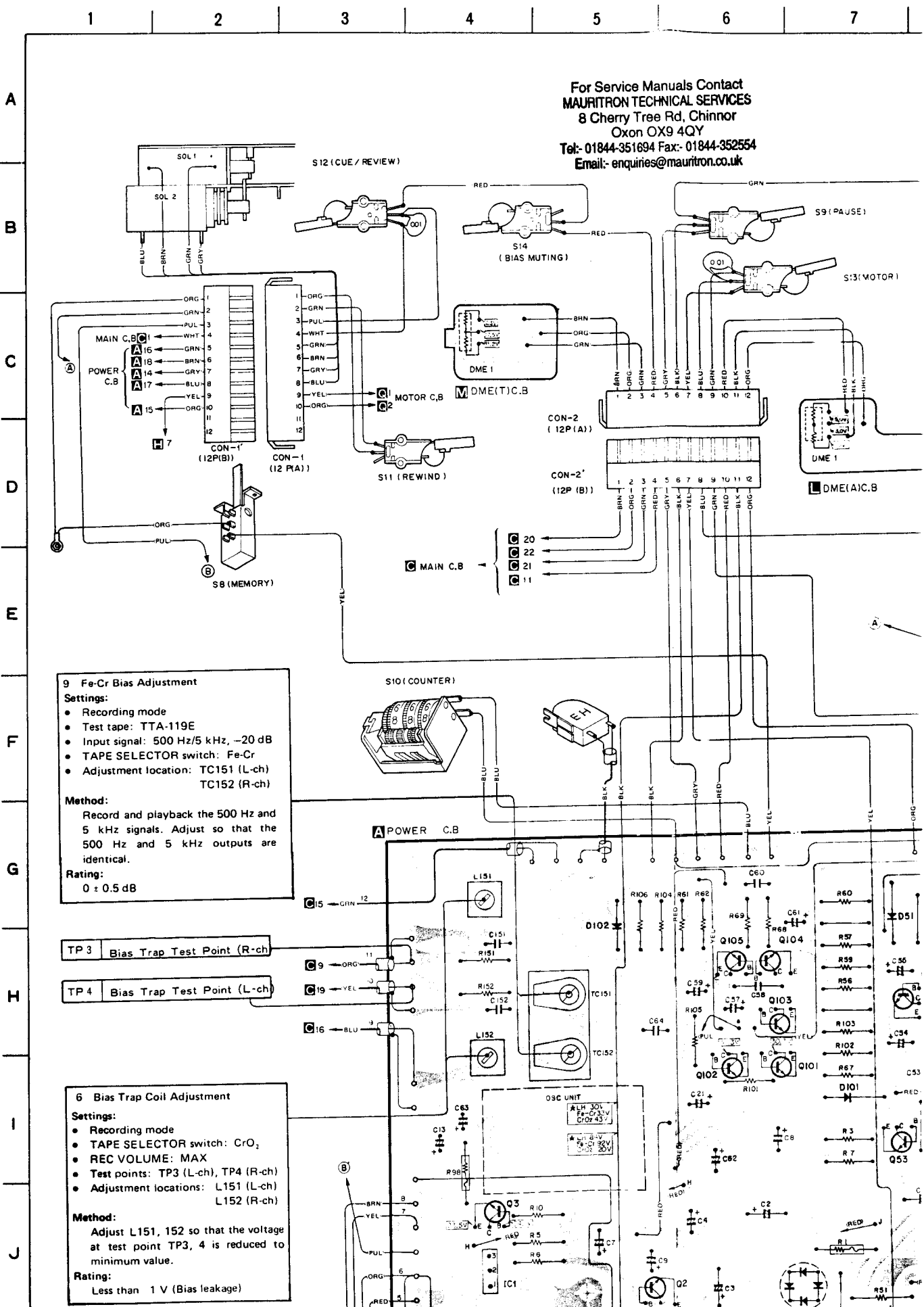

For Service Manuals Contact
MAURITRON TECHNICAL SERVICES
 8 Cherry Tree Rd, Chinnor
 Oxon OX9 4QY
 Tel: 01844-351694 Fax: 01844-352554
 Email: enquiries@mauritron.co.uk

9 Fe-Cr Bias Adjustment
Settings:

- Recording mode
- Test tape: TTA-119E
- Input signal: 500 Hz/5 kHz, -20 dB
- TAPE SELECTOR switch: Fe-Cr
- Adjustment location: TC151 (L-ch)
TC152 (R-ch)

Method:
 Record and playback the 500 Hz and 5 kHz signals. Adjust so that the 500 Hz and 5 kHz outputs are identical.

Rating:
 0 ± 0.5 dB

TP3 Bias Trap Test Point (R-ch)
 TP4 Bias Trap Test Point (L-ch)

6 Bias Trap Coil Adjustment
Settings:

- Recording mode
- TAPE SELECTOR switch: CrO₂
- REC VOLUME: MAX
- Test points: TP3 (L-ch), TP4 (R-ch)
- Adjustment locations: L151 (L-ch)
L152 (R-ch)

Method:
 Adjust L151, 152 so that the voltage at test point TP3, 4 is reduced to minimum value.

Rating:
 Less than 1 V (Bias leakage)

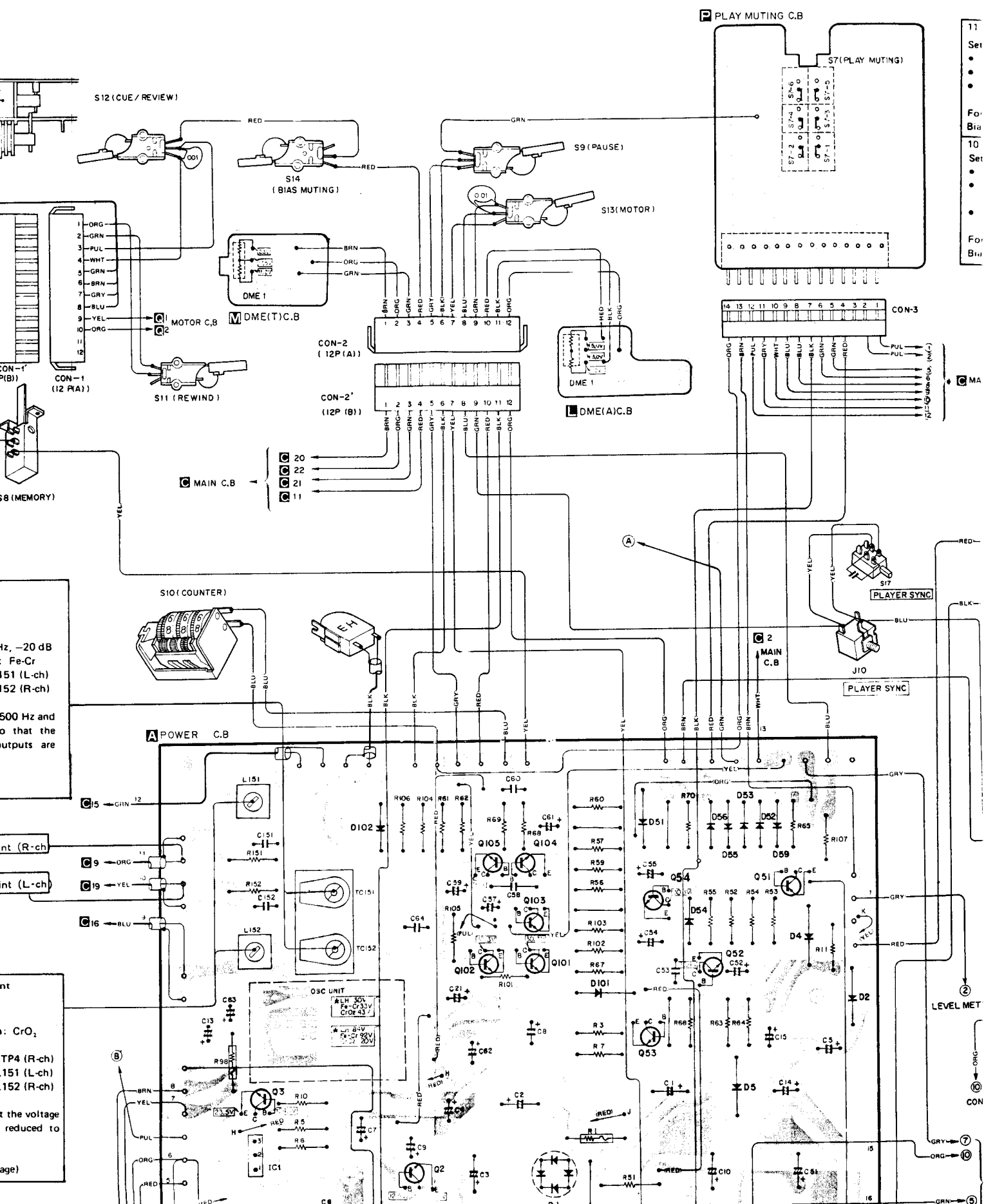

- 11 Set
-
-
-
- For
- Bias
- 10 Set
-
-
- For
- Bias

S12 (CUE / REVIEW)

CON-1 (12 RA)

CON-1 (12 RA)

S11 (REWIND)

S10 (COUNTER)

500 Hz and to that the outputs are

151 (L-ch)

152 (R-ch)

151 (L-ch)

152 (R-ch)

151 (L-ch)

152 (R-ch)

151 (L-ch)

152 (R-ch)

151 (L-ch)

152 (R-ch)

MA

PLAYER SYNC

PLAYER SYNC

LEVEL MET

CON

20

22

21

11

POWER C.B.

OSC UNIT

TC151

TC152

Q1-Q5

D1-D6

R1-R10

C1-C10

S13 (MOTOR)

S14 (BIAS MUTING)

S9 (PAUSE)

S17 (PLAY MUTING)

CON-2 (12P (A))

CON-2 (12P (B))

CON-3

MAIN C.B.

J10

7

8

9

10

11

12

13

14

PLAY MUTING C.B

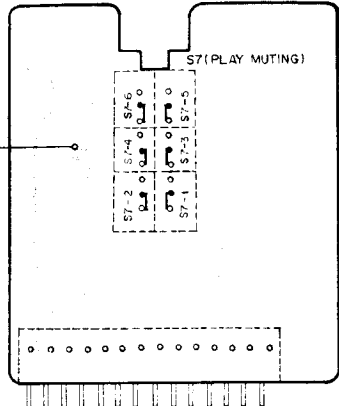

11 LH Bias Adjustment

Settings:
 • Test tape: TTA-119A
 • TAPE SELECTOR switch: LH
 • Adjustment location:
 R20, R21, R22
 For others, proceed as for 9 Fe-Cr Bias Adjustment.

10 CrO₂ Bias Adjustment

Settings:
 • Test tape: TTA-119G
 • TAPE SELECTOR switch: CrO₂
 • Adjustment location:
 R17, R18, R19
 For others, proceed as for 9 Fe-Cr Bias Adjustment.

13 REC./PB. Sensitivity Adjustment

Settings:
 1. Fe-Cr tape
 • Recording mode
 • Test tape: TTA-119E
 • Input signal: 1 kHz, 0VU
 • TAPE SELECTOR switch: Fe-Cr
 • Adjustment locations:
 SFR3 (L-ch), SFR4 (R-ch)
 Method:
 Play back test tape and adjust so that the output becomes 0.755 V.

Rating:
 0.775 V ± 0.3 dB
 Settings differ as below Cr₂O₃ and LH
 2. CrO₂ tape
 Settings:
 • Test tape: TTA-119G
 • TAPE SELECTOR switch: Cr₂O₃
 • Adjustment locations:
 SFR5 (L-ch), SFR6 (R-ch)
 3. LH tape
 Settings:
 • Test tape: TTA-119A
 • TAPE SELECTOR switch: L
 • Adjustment locations:
 SFR1 (L-ch), SFR2 (R-ch)

For Service Manuals Contact
MAURITRON TECHNICAL SERVICES
 8 Cherry Tree Rd, Chinnor
 Oxon OX9 4QY
 Tel: 01844 361694 Fax: 01844 352554
 Email: enquiries@mauritron.co.uk

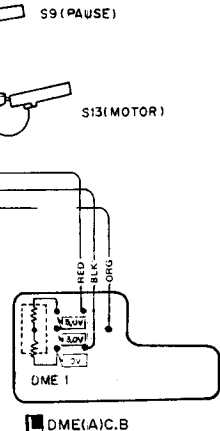

MAIN C.B

LED(R).C.B

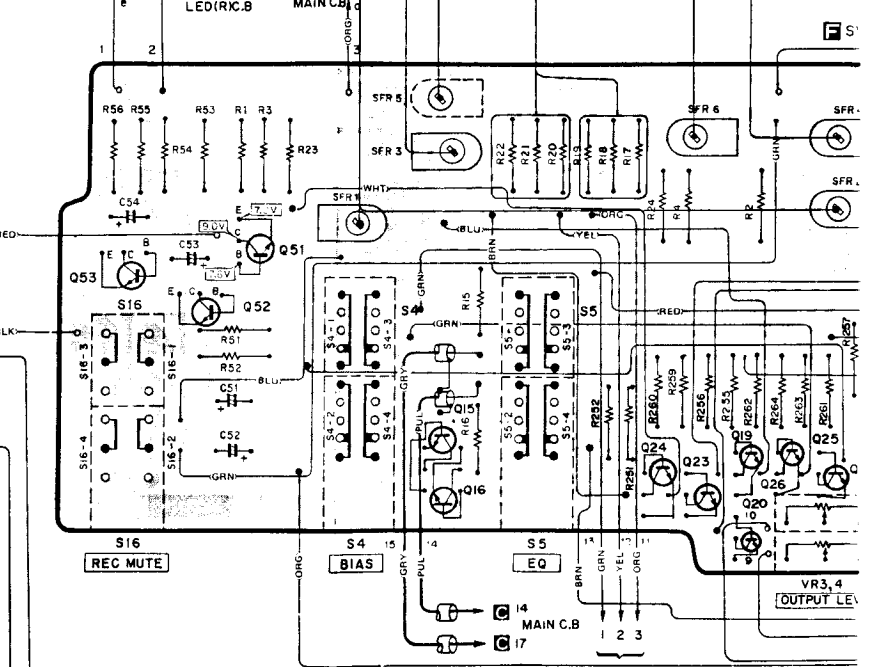

1 Tape Speed Adjustment

Settings:
 • Test tape: TTA-111
 • TAPE SELECTOR switch: LH
 • Adjustment location: SFR1
 Method:
 Play back the test tape and adjust so that the frequency is 3 kHz, both at the start and the end of tape winding.

METER/PEAK C.B

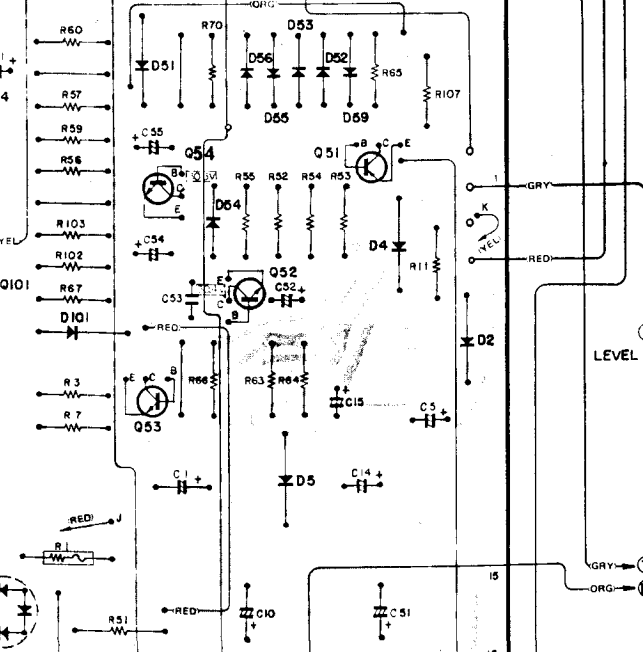
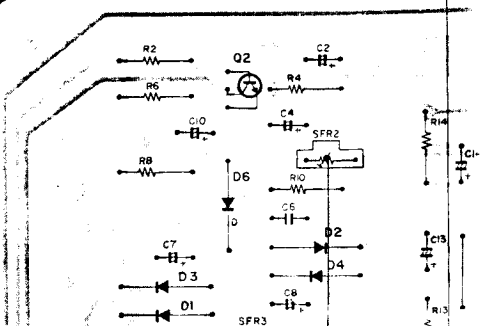

REC/PB. Sensitivity Adjustment

Fe-Cr tape
Settings:
Recording mode
Test tape: TTA-119E
Input signal: 1 kHz, 0VU
TAPE SELECTOR switch:
Fe-Cr
Adjustment locations:
SFR3 (L-ch), SFR4 (R-ch)

Method:
Play back test tape and adjust so that the output becomes 0.755 V.

Rating:
0.775 V ± 0.3 dB
Settings differ as below CrO₂ and LH

2. CrO₂ tape
Settings:
• Test tape: TTA-119G
• TAPE SELECTOR switch: CrO₂
• Adjustment locations: SFR5 (L-ch), SFR6 (R-ch)

3. LH tape
Settings:
• Test tape: TTA-119A
• TAPE SELECTOR switch: LH
• Adjustment locations: SFR1 (L-ch), SFR2 (R-ch)

12 Recording Equalizer Adjustment

1. Fe-Cr tape
Settings:
• Recording mode
• Test tape: TTA-119E
• Input signal: 500 Hz/13 kHz, -20 dB
• TAPE SELECTOR switch: Fe-Cr
• Adjustment locations: L3 (L-ch), L4 (R-ch)

Method:
Record and playback the 500 Hz and 13 kHz signals. Adjust so that the 500 Hz and 13 kHz output deviation are +0.5 dB, -1.5 dB.

Settings differ as below CrO₂ and LH.

2. CrO₂ tape
Settings:
• Test tape: TTA-119G
• TAPE SELECTOR switch: CrO₂
• Adjustment locations: L5 (L-ch), L6 (R-ch)

Rating:
0 +0.5 dB
-1.5

3. LH tape
Settings:
• Test tape: TTA-119A
• TAPE SELECTOR switch: LH
• Adjustment locations: L1 (L-ch), L2 (R-ch)

Rating:
0 +0.5 dB
-2.0

For Service Manuals Contact
MAURITRON TECHNICAL SERVICES
8 Cherry Tree Rd, Chinnor
Oxon OX9 4QY
Tel: 01844-351694 Fax: 01844-352554
Email: enquiries@maurtron.co.uk

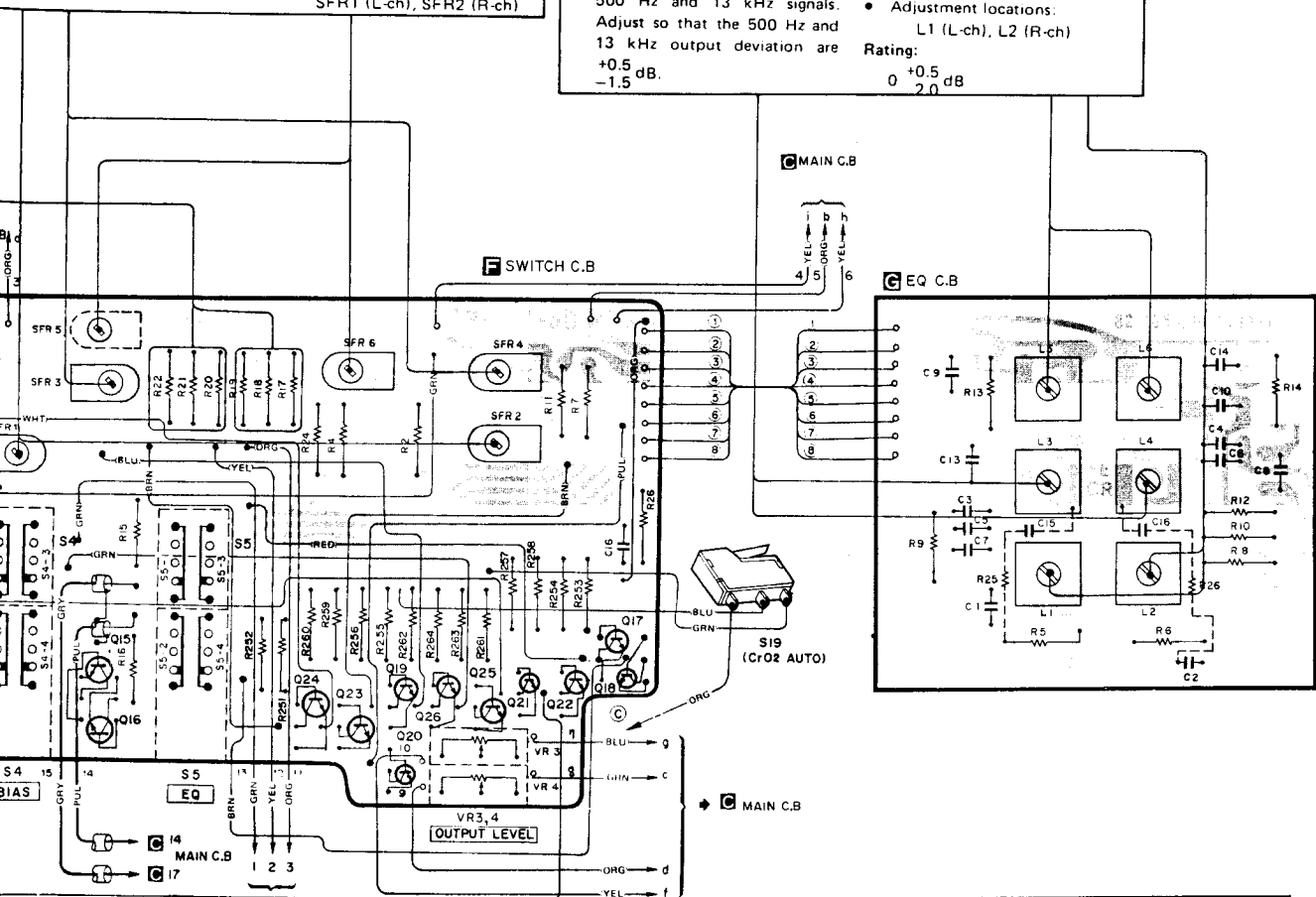

1 Tape Speed Adjustment

Settings:
• Test tape: TTA-111
• TAPE SELECTOR switch: LH
• Adjustment location: SFR1

Method:
Play back the test tape and adjust so that the frequency is 3 kHz, both at the start and the end of tape winding.

7 Level Meter Adjustment

Settings:
• Recording mode
• Input signal: 0VU (Output = 0.775 V)
• Adjustment location: SFR1 (L-ch), SFR2 (R-ch)

Method:
Adjust SFR1, 2 so that the indicator of the level meter points to 0VU.

8 9 Points Peak Indicator Adjustment

Settings:
• Recording mode
• Input signal: 1 kHz, -10 dB
• Adjustment location: SFR3

Method:
All LED lights up when the input signal is increased by 3 dB. Adjust SFR3 so that put out the red LED. (+4 dB)

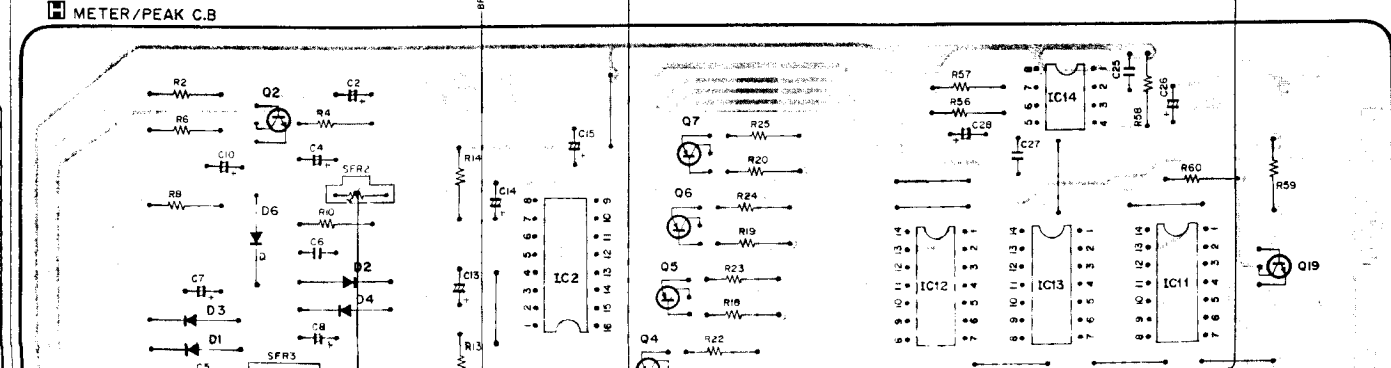

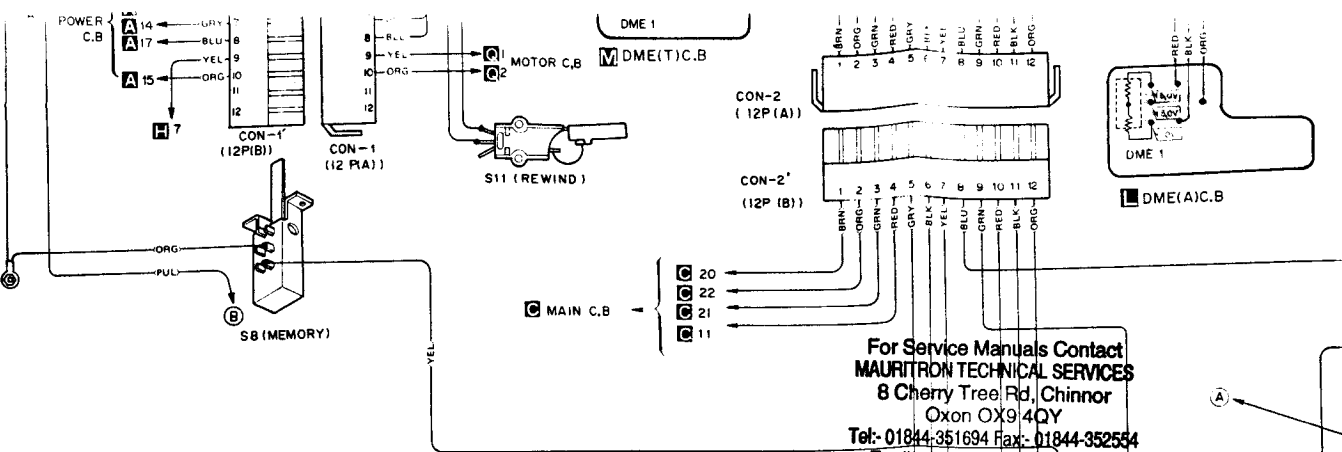

For Service Manuals Contact
MAURITRON TECHNICAL SERVICES
 8 Cherry Tree Rd, Chinnor
 Oxon OX9 4QY
 Tel: 01844-351694 Fax: 01844-352554
 Email: enquiries@mauritron.co.uk

9 Fe-Cr Bias Adjustment
Settings:

- Recording mode
- Test tape: TTA-119E
- Input signal: 500 Hz/5 kHz, -20 dB
- TAPE SELECTOR switch: Fe-Cr
- Adjustment location: TC151 (L-ch)
TC152 (R-ch)

Method:
 Record and playback the 500 Hz and 5 kHz signals. Adjust so that the 500 Hz and 5 kHz outputs are identical.

Rating:
 0 : 0.5 dB

TP 3 Bias Trap Test Point (R-ch)
 TP 4 Bias Trap Test Point (L-ch)

6 Bias Trap Coil Adjustment
Settings:

- Recording mode
- TAPE SELECTOR switch: CrO₂
- REC VOLUME: MAX
- Test points: TP3 (L-ch), TP4 (R-ch)
- Adjustment locations: L151 (L-ch)
L152 (R-ch)

Method:
 Adjust L151, 152 so that the voltage at test point TP3, 4 is reduced to minimum value.

Rating:
 Less than 1 V (Bias leakage)

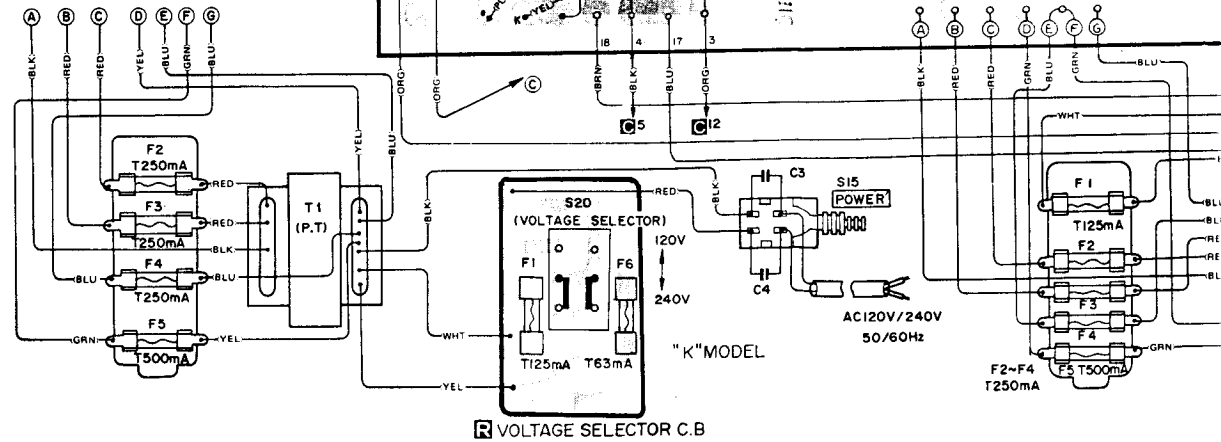
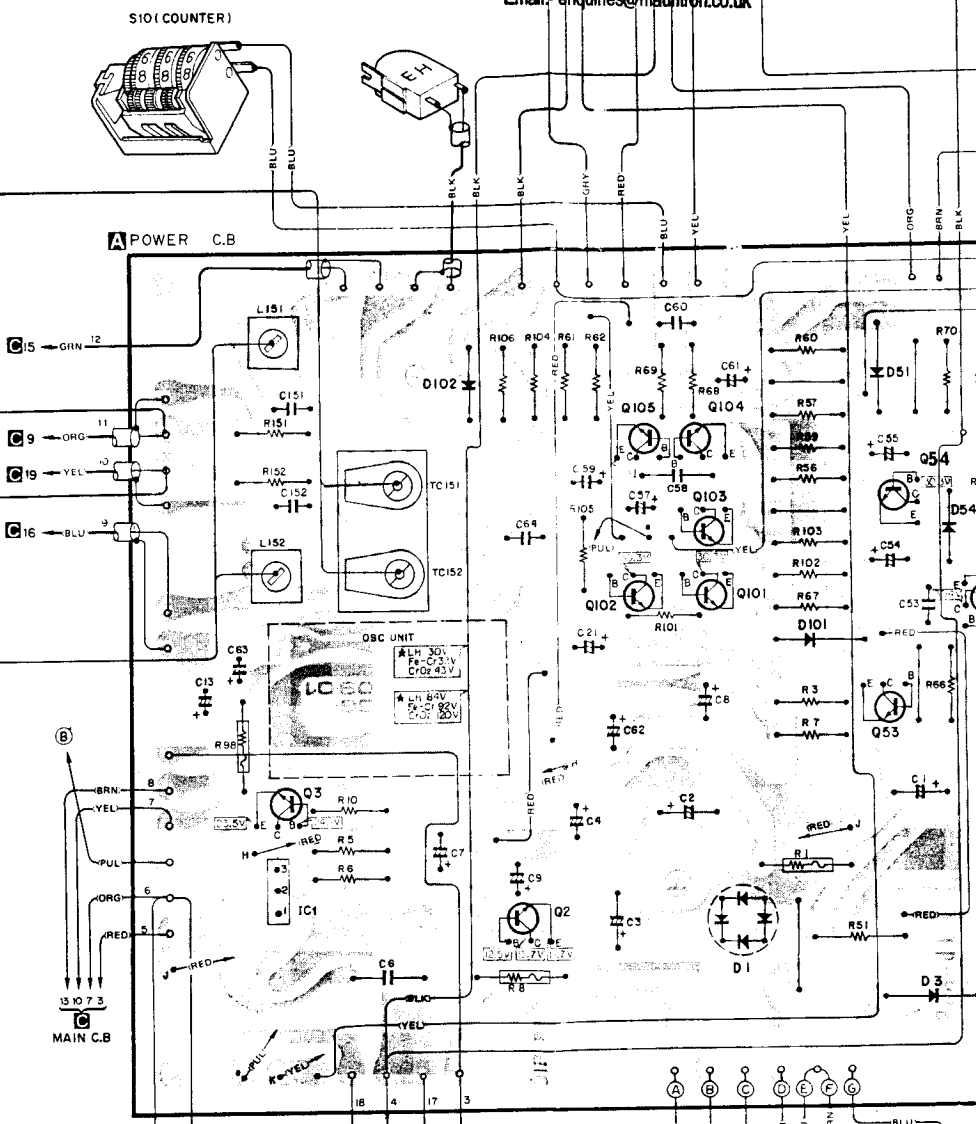

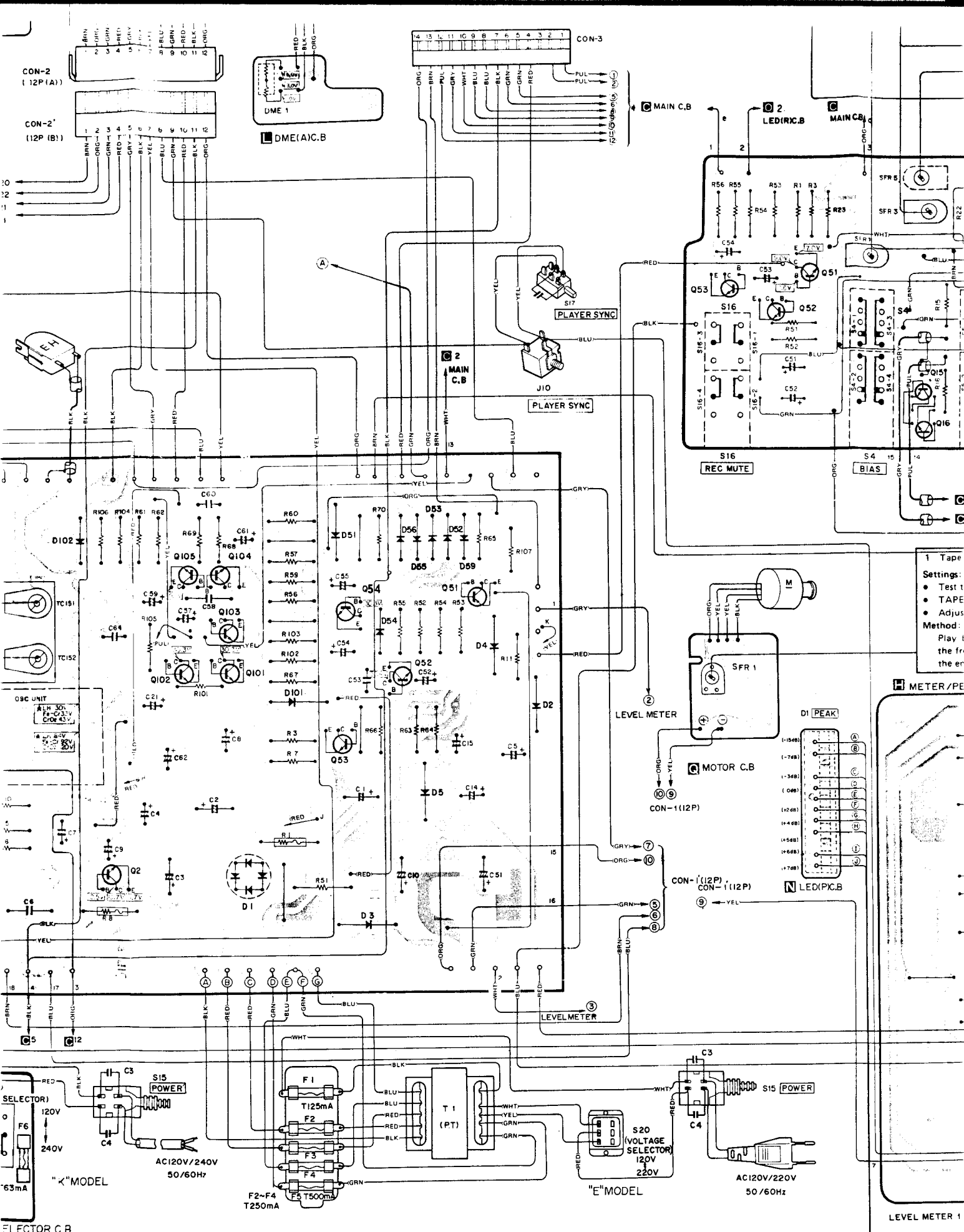

- 1 Tape Settings:
- Test t
 - TAPE
 - Adjus
- Method:
- Play t
 - the fr
 - the en

METER/PE

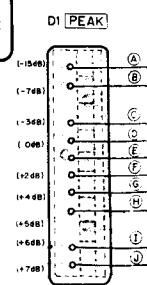

For Service Manuals Contact
MAURITRON TECHNICAL SERVICES
 8 Cherry Tree Rd, Qinor
 Oxon OX9 4QY
 Tel: 01844-351694 Fax: 01844-352554

Others pattern

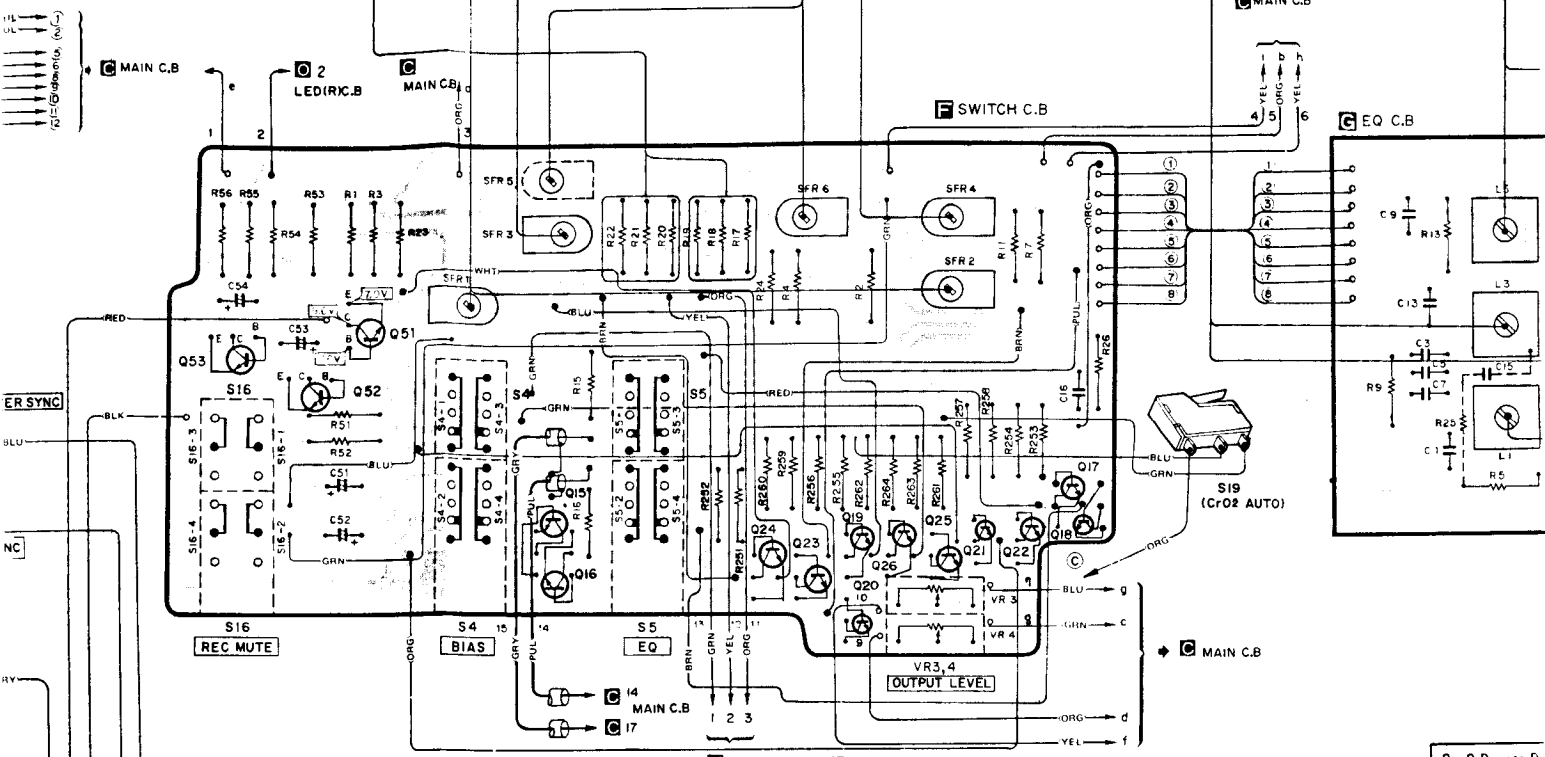

1 Tape Speed Adjustment

Settings:

- Test tape: TTA-111
- TAPE SELECTOR switch: LH
- Adjustment location: SFR1

Method:

Play back the test tape and adjust so that the frequency is 3 kHz, both at the start and the end of tape winding.

7 Level Meter Adjustment

Settings:

- Recording mode
- Input signal: 0VU (Output = 0.775 V)
- Adjustment location: SFR1 (L-ch), SFR2 (R-ch)

Method:

Adjust SFR1, 2 so that the indicator of the level meter points to 0VU.

8 9 Points P

Settings:

- Recording mode
- Input signal
- Adjustment

Method:

All LED in signal is SFR3 so that (-4 dB)

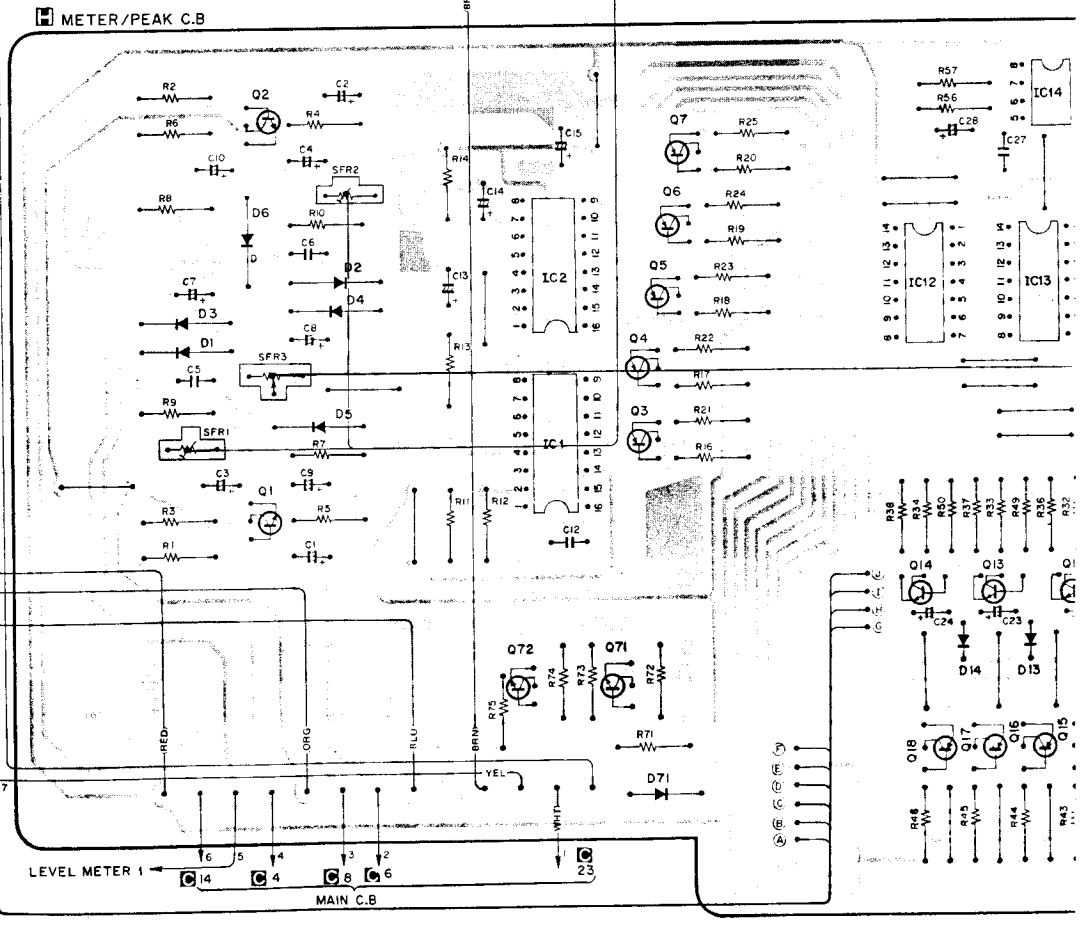
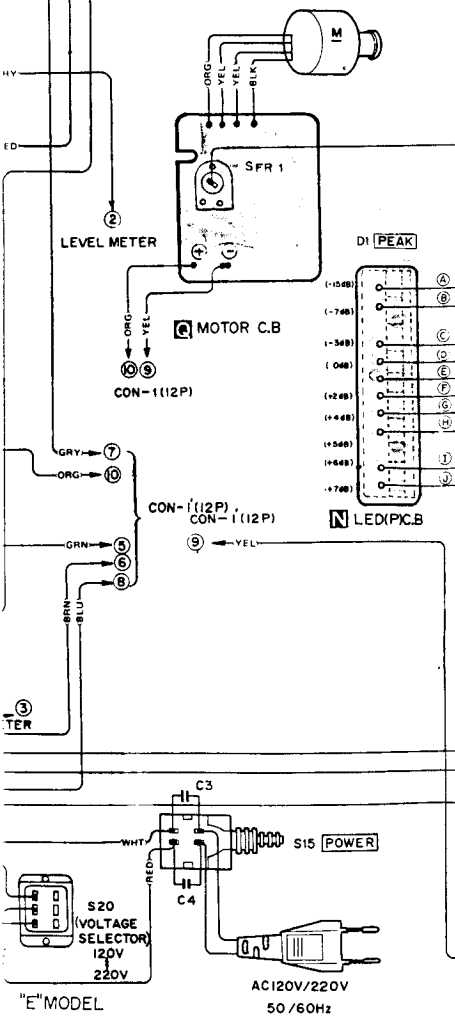

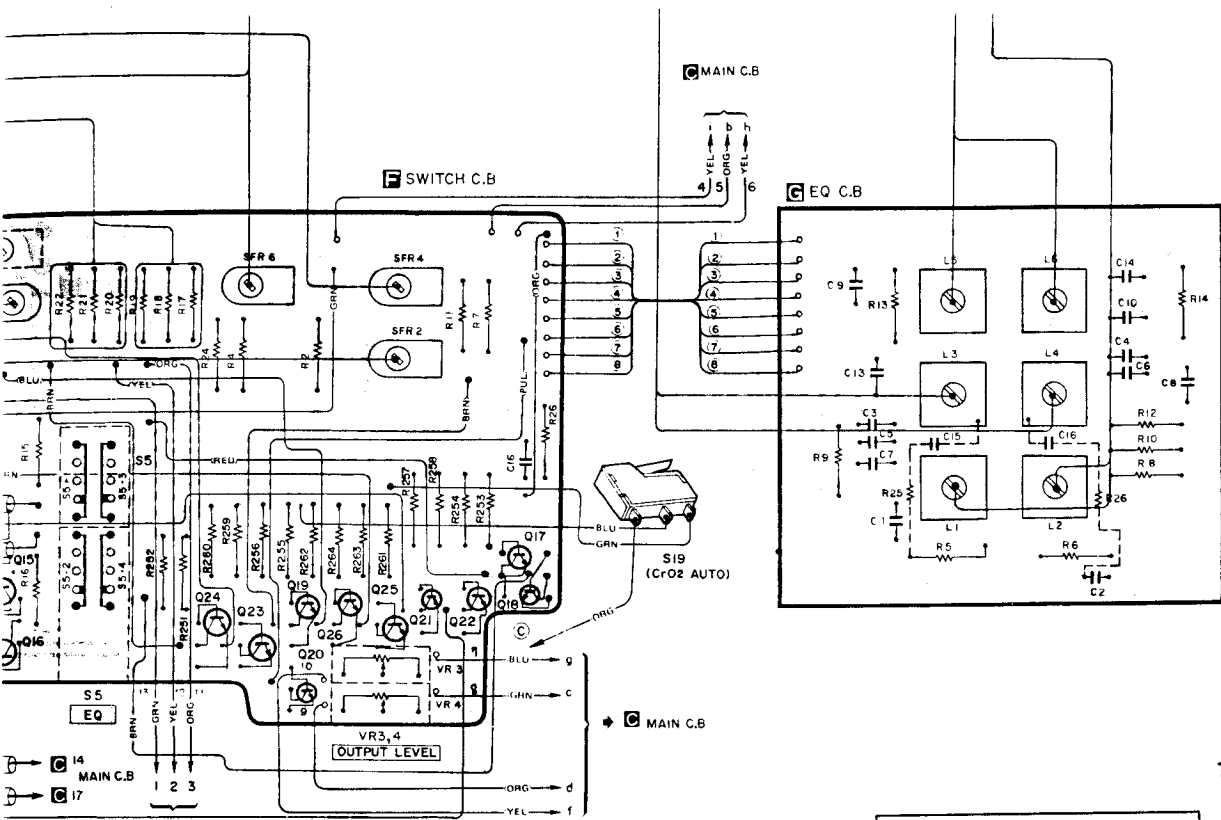

For Service Manuals Contact
MAURITRON TECHNICAL SERVICES
 8 Cherry Tree Rd, Chinnor
 Oxon OX9 4QY
 Tel:- 01844-351694 Fax:- 01844-352554
 Email:- enquiries@mauritron.co.uk

1 Tape Speed Adjustment
Settings:

- Test tape: TTA-111
- TAPE SELECTOR SWITCH LH
- Adjustment location: SFR1

Method:
 Play back the test tape and adjust so that the frequency is 3 kHz, both at the start and the end of tape winding.

7 Level Meter Adjustment
Settings:

- Recording mode
- Input signal: 0VU (Output = 0.775 V)
- Adjustment location: SFR1 (L-ch), SFR2 (R-ch)

Method:
 Adjust SFR1, 2 so that the indicator of the level meter points to 0VU.

8 9 Points Peak Indicator Adjustment
Settings:

- Recording mode
- Input signal: 1 kHz, -10 dB
- Adjustment location: SFR3

Method:
 All LED lights up when the input signal is increased by 3 dB. Adjust SFR3 so that put out the red LED. (+4 dB)

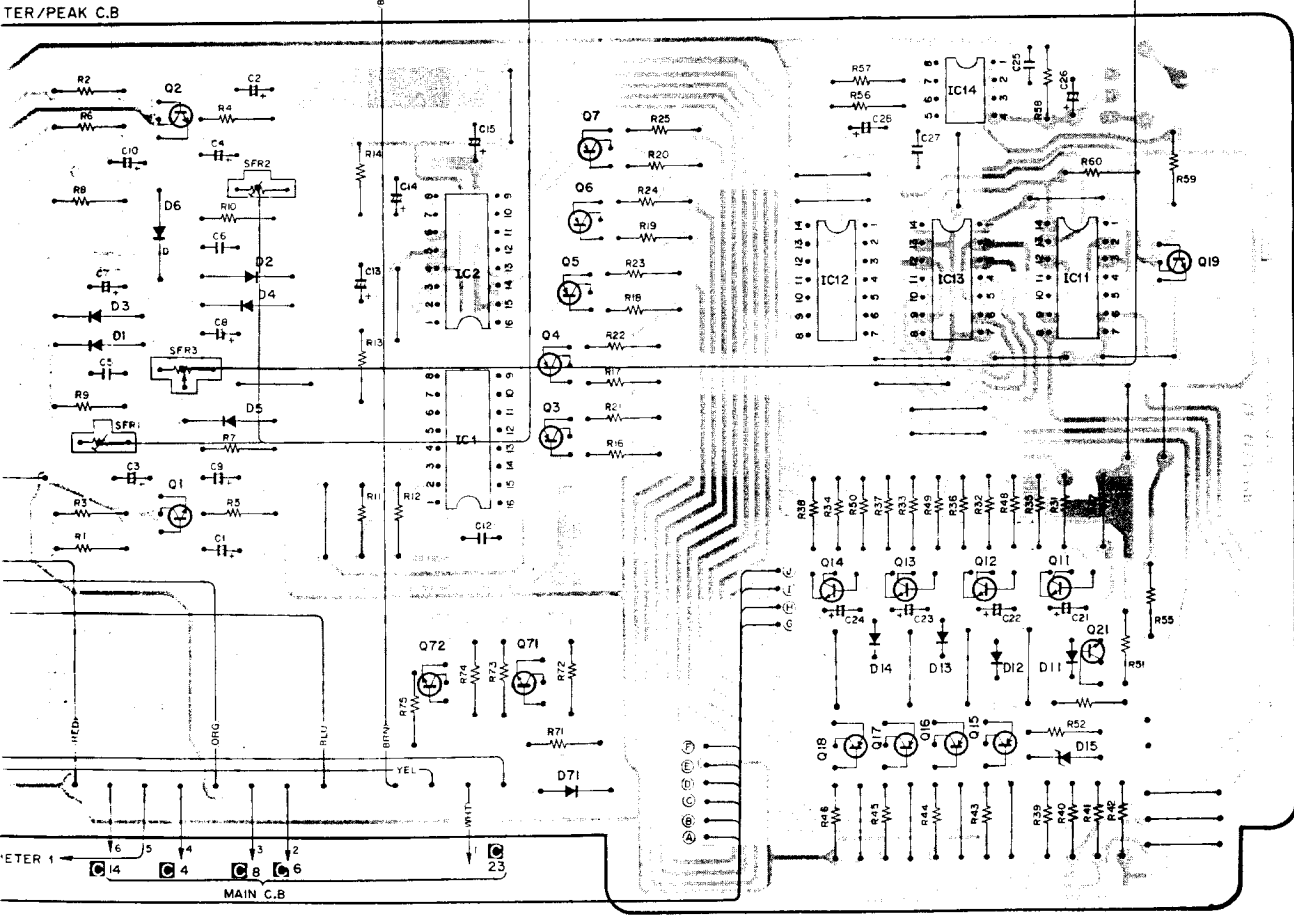

METER 1
 MAIN C.B.