

STEREO CASSETTE DECK WITH DOLBY NR SYSTEM

MODEL NO. AD-6900E, K, G

AIWA® [SERVICE MANUAL]

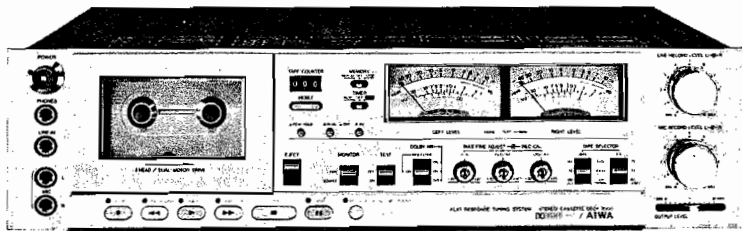

DATE OF ISSUE 9/1978

SPECIFICATIONS

Semiconductors:	13 IC's, 171 transistors, 82 diodes, 12 FET's & 6 LED's	Frequency response:	LH type, 20~16 kHz 25~14 kHz ($+2$ -3 dB)
Power source:	AC 110~120V/220V/240V (E model) AC 120V/240V (K, G model) (switchable) 50/60 Hz, 50Hz		Fe-Cr tape, 20~20 kHz 25~18 kHz ($+2$ -3 dB)
Power consumption:	26W		CrO ₂ tape, 20~19 kHz 25~17 kHz ($+2$ -3 dB)
Dimensions:	450(W) x 120(H) x 327(D) mm	Motor:	38 pulse FG servo motor (for capstan) DC servo motor
Weight:	9.8 kg	Head:	V-cut combination ferrite head (for Rec./Pb) Double cap ferrite head (for Erasure)
Track system:	4-track 2-channel stereo	Input:	MIC; Max. input sensitivity 0.25 mV (200 Ω ~10 k Ω suitable)
Tape speed:	4.76 cm/sec. \pm 0.5%		LINE IN; Max. input sensitivity 75 mV (More than 50 k Ω)
Wow & flutter:	Less than 0.04% (WRMS) at Pb	Output:	DIN; Max. input sensitivity 0.25 mV (50 k Ω)
Automatic stop system:	Full auto-stop		LINE OUT; Standard output level 0.41V (0 VU) Optimum load impedance More than 50 k Ω
Automatic shut-off action time:	2 \pm 0.5 sec.		DIN; Standard output level 0.41 V (0 VU) Optimum load impedance More than 50 k Ω
Pinch roller pressure:	580 $+70$ -40 g		PHONES; 8 Ω ~150 Ω
Take-up torque:	50 \pm 10 g-cm		
FF & rewind torque:	155 \pm 25 g-cm		
FF & rewind time:	65 \pm 5 sec. (w/c-60 cassette)		
Unattended recording acting time:	3 sec.		
Playback output:	0.58 \pm 0.06 V (LINE)		
(TTA-161)			
Playback noise:	Less than 3.5 mV (LH, DOLBY OFF) Less than 1.0 mV (Fe-Cr, CrO ₂ , DOLBY ON)		
(Un-Weighted)			
Rec./Pb output:	0 VU \pm 1.0 dB (LINE)		
(400 Hz 0 VU)			
Rec./Pb distortion:	Less than 1.5% (LH) Less than 1.0% (Fe-Cr) Less than 1.5% (CrO ₂)		
(400 Hz 0 VU)			
Rec./Pb S/N:	More than 40/45 dB (LH, DOLBY OFF/ON)		
(400 Hz 0 VU)			
(Un-Weighted)	More than 43/46 dB (Fe-Cr, CrO ₂ , DOLBY OFF/ON)		
Channel separation:	More than 30 dB		
(1 kHz 0 VU)			
Cross talk:	More than 60 dB		
(1 kHz 0 VU)			
Erasing ratio:	More than 60 dB		
(400 Hz 0 VU +10 dB)			
VU meter display error:	0 VU \pm 0.5 dB		
(0 VU)			
Peak meter display error:	(0 VU +7 dB) +7 dB \pm 1 dB (0 VU -10 dB) -10 dB \pm 1 dB (0 VU -20 dB) -20 dB \pm 2 dB		
Bias frequency:	105 kHz		

- Specifications and external appearance are subject to change without notice due to product improvement.
- Dolby Noise Reduction System is licensed from Dolby Laboratories Incorporated.
- The name "Dolby" and the "Double D" symbol are trademarks of Dolby Laboratories Incorporated.

DISASSEMBLY INSTRUCTIONS

To Remove Top Panel

- 1) Remove 7 screws.

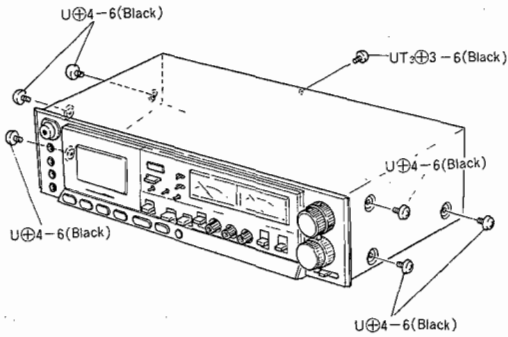

To Remove Front Panel

- 1) Pull out the 13 knobs.
- 2) Remove 6 screws.

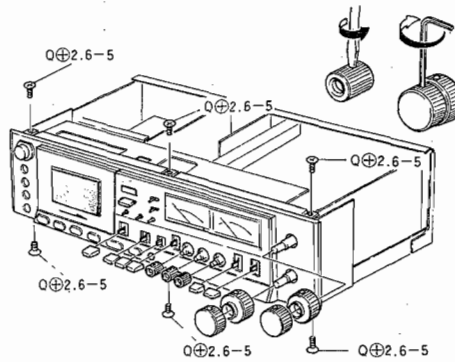

To Remove Cassette Lid, Blinder and Cassette Plate

- 1) Remove the cassette lid.
- 2) Remove the blinder.
- 3) Remove 2 screws, securing the cassette plate in place.

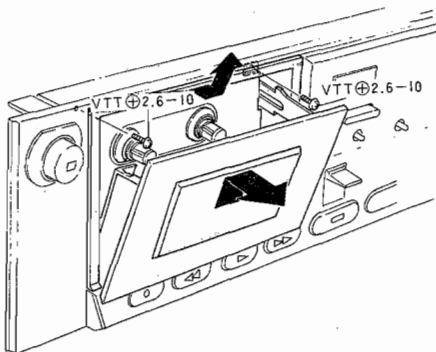

To Remove REC/PB Circuit Board

- 1) Remove 2 circuit board holders.
- 2) Disconnect 2 connectors.
- 3) Remove 8 screws.

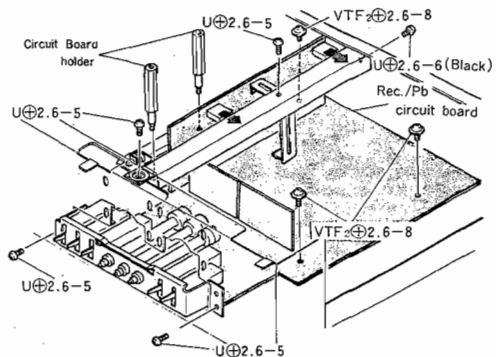

To Remove System Logic Circuit Board
 1) Remove 4 screws.

To Remove Key Logic Circuit Board
 1) Disconnect 2 connectors.
 2) Remove 2 screws.

To Remove Mechanism
 1) Remove 2 screws, securing the player shync circuit board in place.
 2) Remove 4 screws, securing the power transformer in place.
 3) Remove 2 screws, securing the power switch holder in place.
 4) Remove the counter belt and main belt.
 5) Remove the rod stoppers and take out the selector rods.

To Remove Front Panel B Ass'y
 1) Remove 2 nuts.
 2) Remove 2 screws.

To Remove Switch Board Ass'y and Switch Circuit Board
 1) Remove 2 nuts.
 2) Remove 7 screws.

To Remove FRTS Circuit Board
 1) Remove 5 screws.

6) Remove 10 screws.

☆☆☆☆☆☆☆☆☆☆☆☆☆☆☆☆ MEMO ☆☆☆☆☆☆☆☆☆☆☆☆☆☆☆

EXPLODED VIEW-1

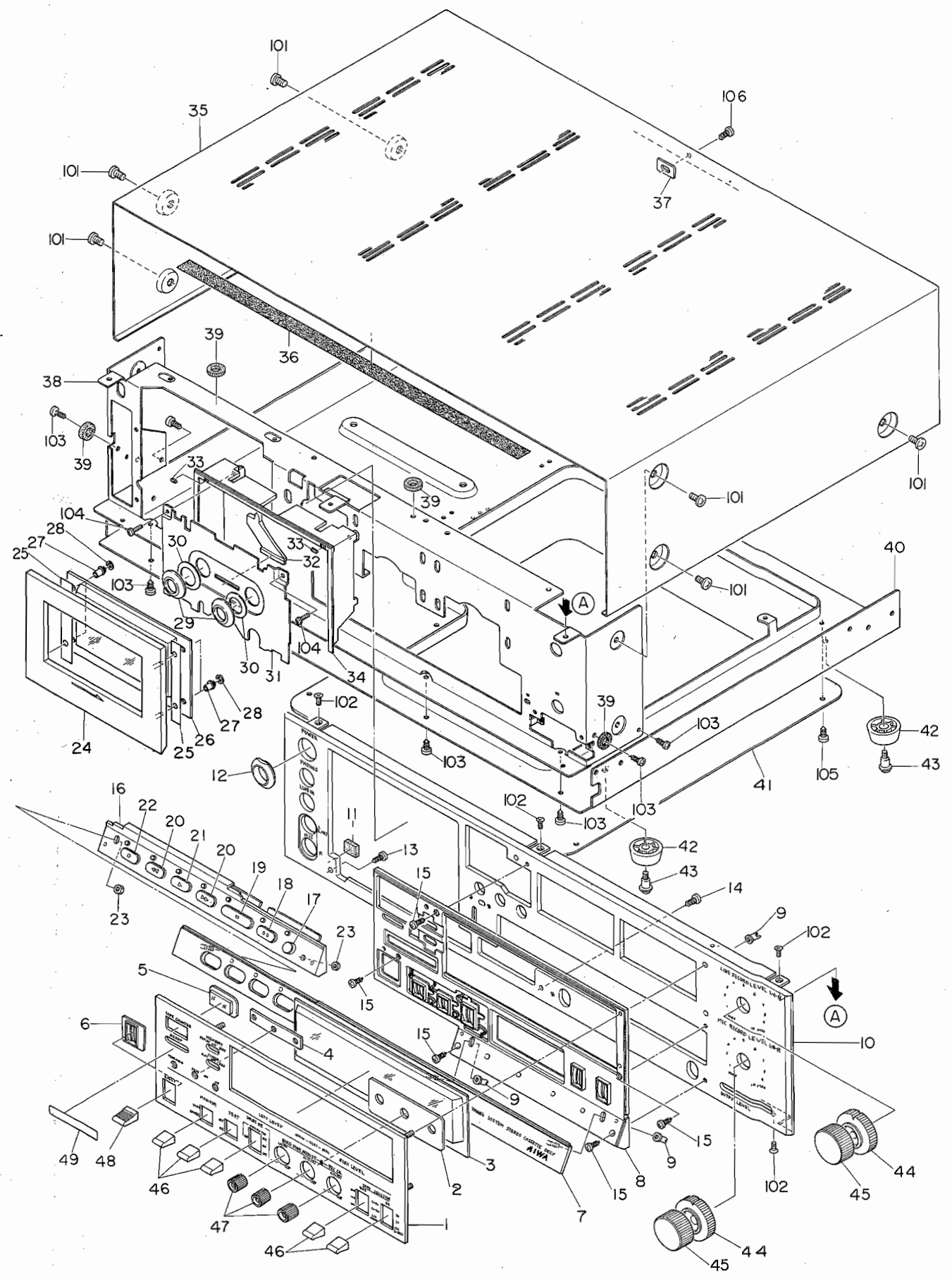

PARTS LIST

MECHANICAL PARTS

■ * mark in this part list shows exclusive part
(which is used) for only Model AD-6900.

Ref. No.	Part No.	Part No. Changed to	Description	Common Model	Q'ty
1-1	82-304-004-11		Front panel A ass'y	*	1
1-2	82-304-053-01		Cover, Bias	*	1
1-3	82-304-026-01		Window, Meter	*	1
1-4	82-304-255-01		Guide, Push button	*	1
1-5	82-304-061-01		Window, Counter	*	1
1-6	82-304-051-01		Cover, Eject	*	1
1-7	82-304-010-01		Front panel B ass'y	*	1
1-8	82-304-008-01		Front panel (M)	*	1
1-9	82-304-245-01		Nut, 3-9	*	6
1-10	82-304-002-01		Front panel, Base	*	1
1-11	82-303-367-01		Cushion, Actuating lock		1
1-12	82-478-012-01		Ring, Power button		1
1-13	87-342-074-01		UT ₁ + 2.6-8		1
1-14	87-342-075-01		UT ₁ + 2.6-10		1
1-15	87-081-765-01		VT ₂ + 2.6-8		5
1-16	82-304-653-01		Switch board ass'y	*	1
1-17	82-304-060-01		Push key, REC MUTE	*	1
1-18	82-304-058-01		Push key, PAUSE	*	1
1-19	82-304-059-01		Push key, STOP	*	1
1-20	82-304-057-01		Push key, F.F	*	2
1-21	82-304-056-01		Push key, PLAY	*	1
1-22	82-304-055-01		Push key, REC	*	1
1-23	87-391-017-01		N-3		2
1-24	82-304-040-01		Cassette lid ass'y	*	1
1-25	82-304-246-01		Adhesive sheet, Cassette lid	*	2
1-26	82-304-043-01		Window, Cassette lid	*	1
1-27	82-304-231-01		Clamp, Cassette lid	*	4
1-28	87-441-003-01		STE 1.5		4
1-29	82-397-039-01		Ring, Reel table	AD-6550	2
1-30	82-397-290-01		Adhesive sheet, Ring	AD-6550	2
1-31	82-304-073-01		Cassette plate	*	1
1-32	82-304-044-01		Guide, Light	*	1
1-33	82-304-066-01		Cushion, Cassette lid	*	2
1-34	82-304-049-01		Blinder	*	1
1-35	82-304-063-01		Steel cabinet ass'y	*	1
1-36	82-397-245-01		Himeron cloth, Cabinet	AD-6550	1
1-37	82-380-439-01		Spacer, Back panel	AD-6500	1
1-38	82-304-202-21		Chassis, Front	*	1
1-39	82-304-302-01		Spacer, Cushion	*	4
1-40	82-304-201-31		Chassis, Amp.	*	1
1-41	82-304-203-01		Bottom lid	*	1
1-42	87-085-161-01		Leg		4
1-43	82-304-276-01		Screw, Leg	*	4
1-44	82-304-034-01		Knob B ass'y	*	2
1-45	82-304-032-01		Knob A ass'y	*	2
1-46	82-304-030-01		Knob, Selector	*	5
1-47	82-304-036-01		Knob C ass'y	*	3
1-48	82-304-062-01		Knob, Eject key	*	1
1-49	82-304-080-01		Caution label, Timer	*	1

EXPLODED VIEW-2

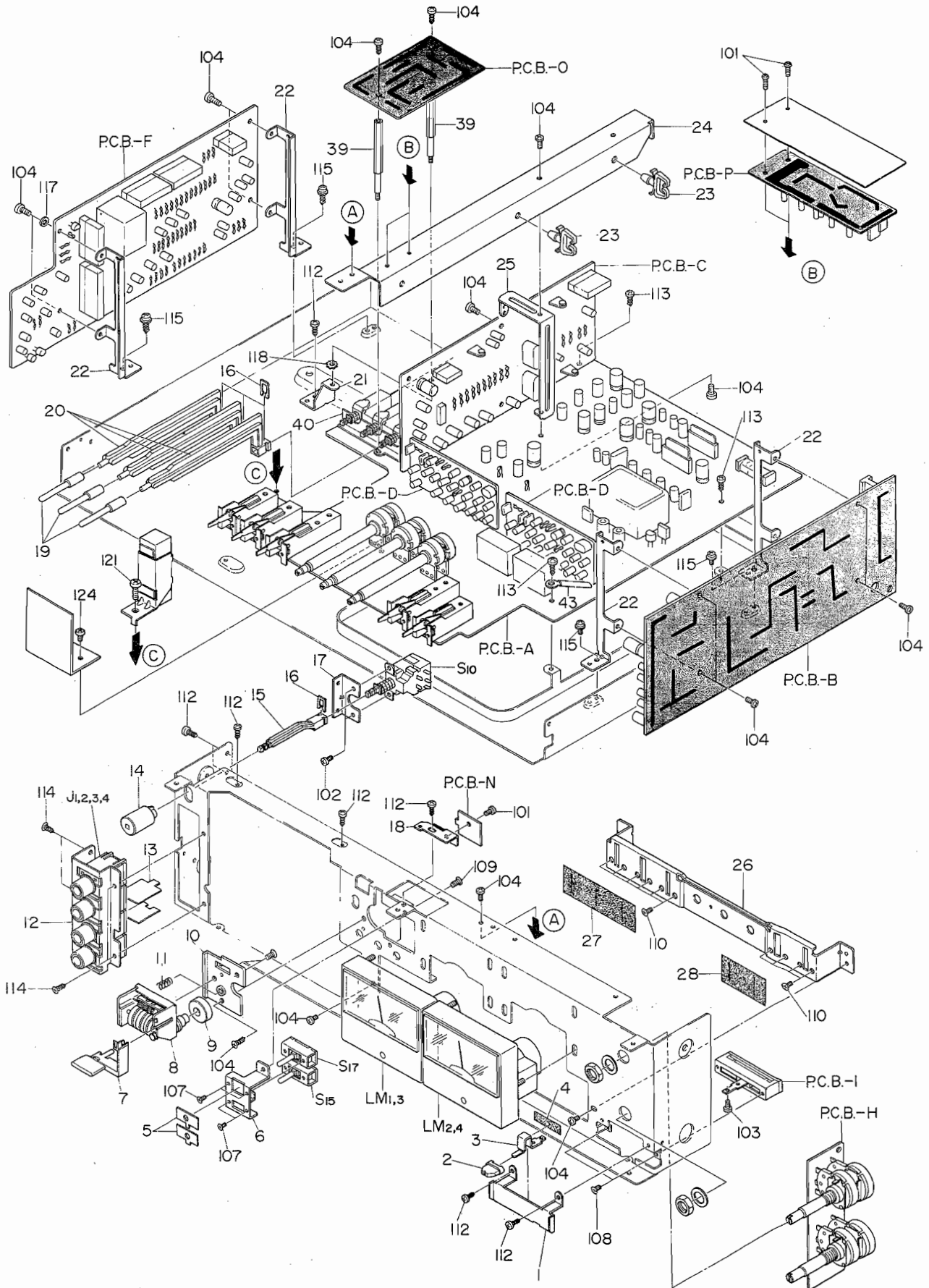

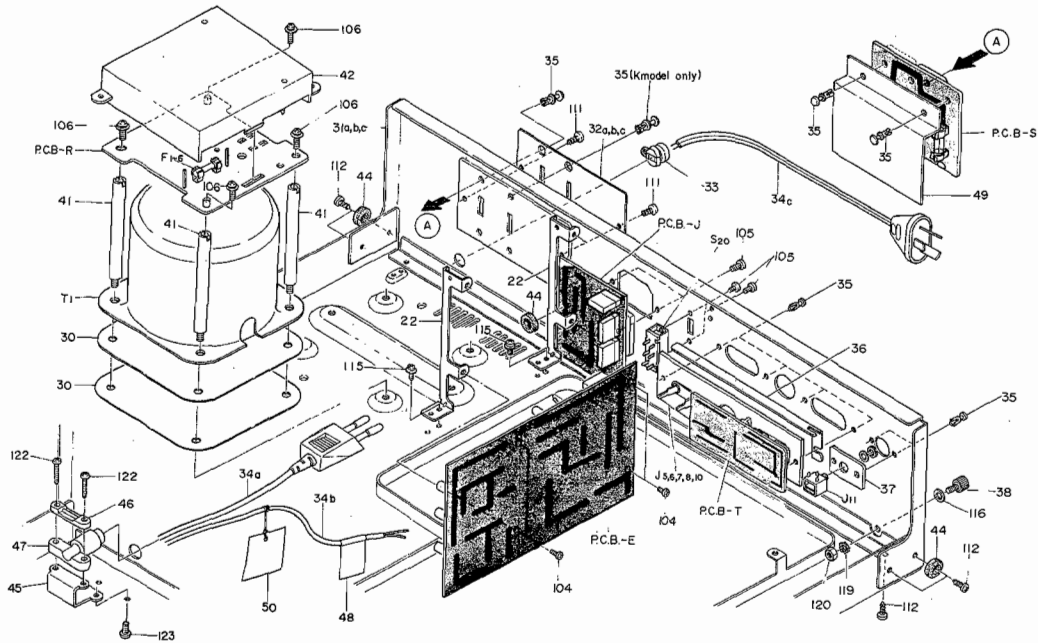

Ref. No.	Part No.	Part No. Changed to	Description	Common Model	Q'ty
2-1	82-304-052-01		Cover, PB volume	*	1
2-2	82-304-054-01		Knob D ass'y	*	1
2-3	82-304-254-01		Holder, Volume	*	1
2-4	82-304-291-01		Himeron cloth, PB volume	*	1
2-5	82-304-048-01		Cover, Selector	*	2
2-6	82-304-205-01		Switch holder B	*	1
2-7	82-304-027-01		Button, RESET	*	1
2-8	87-040-100-01		Counter	*	1
2-9	82-379-617-01		Ring, Magnet	AD-1800	1
2-10	82-304-206-01		Holder, Counter	*	1
2-11	82-304-303-01		Spring, RESET	*	1
2-12	82-304-634-01		Jack ass'y	*	1
2-13	82-304-647-01		Shield plate, Jack	*	1
2-14	82-399-025-01		AC switch button ass'y	*	1
2-15	82-304-210-01		Rod, Power	*	1
2-16	82-385-383-01		Stopper, Rod	*	4
2-17	82-304-258-01		Holder, Power	*	1
2-18	82-397-265-01		Holder, Hall	*	1
2-19	82-304-028-01		Push button	*	3
2-20	82-304-211-01		Rod, Selector	*	3
2-21	82-304-306-01		Holder F, Circuit board	*	1
2-22	82-304-207-01		Holder A, Circuit board	*	6
2-23	87-064-083-01		Wire clip	*	2
2-24	82-304-261-21		Holder C, Circuit board	*	1
2-25	82-304-262-01		Holder D, Circuit board	*	1
2-26	82-304-204-01		Holder A, Switch	*	1
2-27	82-304-273-01		Himeron cloth, Selector A	*	1
2-28	82-304-274-01		Himeron cloth, Selector B	*	1
2-29	82-488-234-01		Holder, Voltage selector	*	1
2-30	82-304-735-01		Shield plate, Power transformer	*	2
2-31a	82-304-014-01		Panel, Back (E model only)	*	1
2-31b	82-304-015-01		Panel, Back (K model only)	*	1
2-31c	82-304-074-01		Panel, Back (G model only)	*	1
2-32a	82-304-020-01		Name plate, Spec. (E model only)	*	1
2-32b	82-304-021-01		Name plate, Spec. (K model only)	*	1
2-32c	82-304-023-01		Name plate, Spec. (G model only)	*	1
2-33	87-085-101-01		Cord bushing (G model only)	*	1
2-34a	87-034-835-01		AC power cord (E model only)	*	1
2-34b	87-034-872-01		AC power cord (K model only)	*	1
2-34c	87-034-846-01		AC power cord (G model only)	*	1
2-35	87-085-102-01		Nylon rivet	E:12 K:10 G:10	1
2-36	82-386-629-01		Shield plate, Jack	AD-1250	1
2-37	82-387-273-01		Holder, Jack	AD-6800	1
2-38	87-033-088-01		Earth terminal	*	1
2-39	82-304-322-01		Holder H, Circuit board	*	2
2-40	82-304-300-01		Holder, Selector switch	*	1
2-41	82-304-325-01		Holder, Circuit board	*	4
2-42	82-304-326-01		Fuse Shield case	*	1
2-43	87-038-039-01		Wire binder	*	1
2-44	82-304-302-01		Cushion, Spacer	*	3
2-45	82-397-244-01		Holder, Pressure AC power cord	AD-6550	1
2-46	87-085-094-01		Pressure AC power cord A	*	1
2-47	87-085-095-01		Pressure AC power cord B	*	1
2-48	87-056-008-01		Label, AC power cord (K model only)	*	1
2-49	82-304-749-01		Insulation plate, Voltage selector	*	1
2-50	87-056-014-01		Tag, Main voltage	*	1

EXPLODED VIEW-3

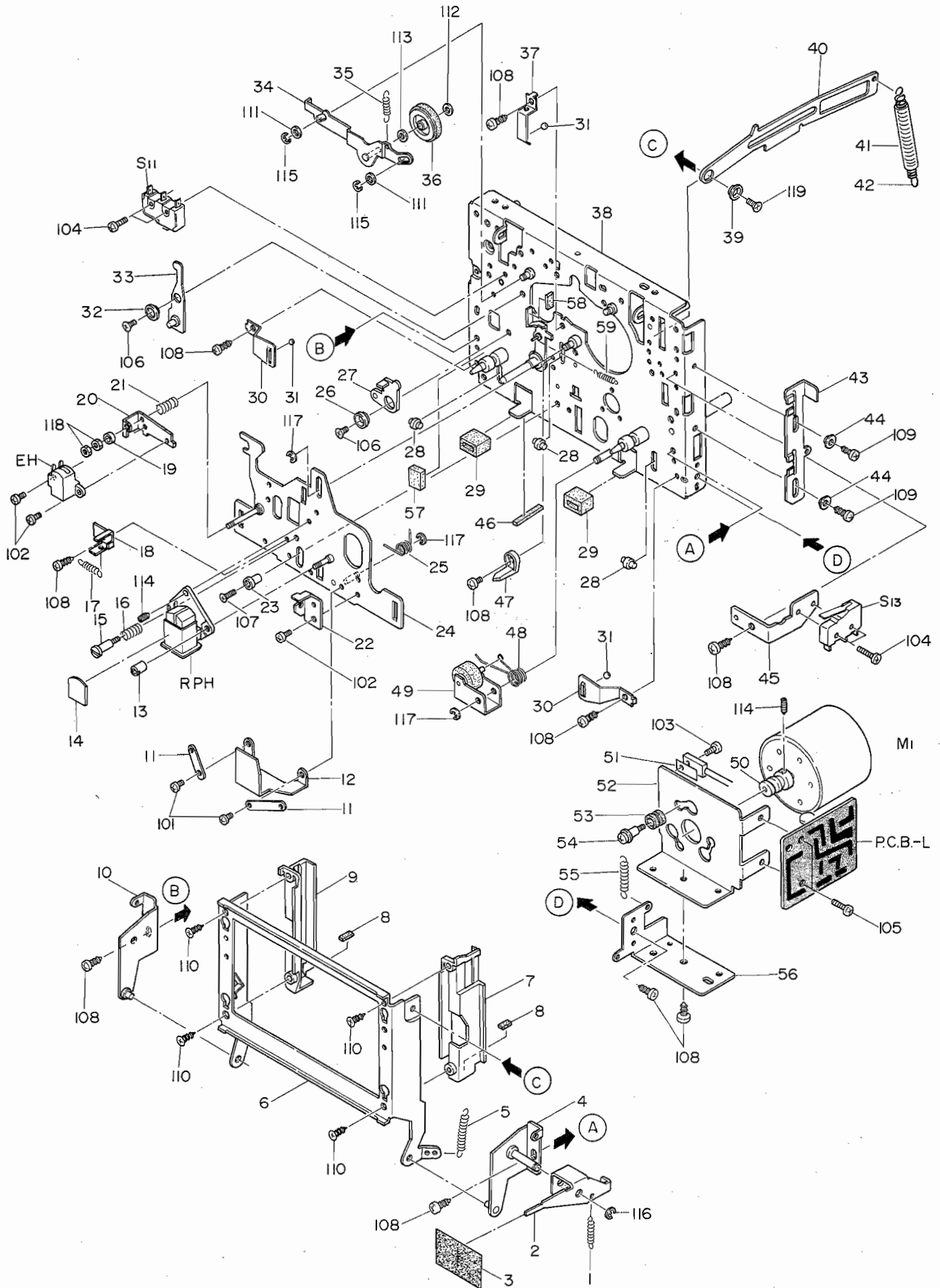

Ref. No.	Part No.	Part No. Changed to	Description	Common Model	Q'ty
3-1	82-304-264-01		Spring, Eject lever	*	1
3-2	82-304-236-01		Lever, Eject key	*	1
3-3	82-304-275-01		Himeron cloth, Eject	*	1
3-4	82-304-215-01		Holder, Cassette box R ass'y	*	1
3-5	82-304-252-01		Spring, Cassette lid	*	1
3-6	82-304-212-01		Cassette box ass'y	*	1
3-7	82-304-046-01		Cassette holder R	*	1
3-8	82-304-284-01		Cushion, Cassette	*	2
3-9	82-304-047-01		Cassette holder L	*	1
3-10	82-304-219-01		Holder, Cassette box L ass'y	*	1
3-11	82-365-280-01		Holder, Wire	*	2
3-12	82-304-308-01		Shield plate,	*	1
3-13	82-304-317-01		Nut, Azimuth	*	1
3-14	82-304-069-01		Label, Head	*	1
3-15	82-304-289-01		Screw, Rec./Pb. head	*	1
3-16	82-304-290-01		Spring, Rec./Pb. head	*	1
3-17	82-303-377-01		Spring A, Erase head		1
3-18	82-303-375-01		Stopper, Erase head		1
3-19	82-303-371-01		Collar, Erase head		1
3-20	82-303-374-01		Holder, Erase head		1
3-21	82-303-376-01		Spring, Erase head		1
3-22	82-303-294-01		Holder, Spring		1
3-23	82-303-306-01		Flange collar, Actuating		1
3-24	82-303-236-01		Actuating chassis ass'y		1
3-25	82-303-315-01		Spring, Actuating		1
3-26	82-303-295-01		Flange collar, Actuating lock		1
3-27	82-303-288-01		Lever, Actuating lock		1
3-28	82-303-302-01		Roller, Actuating		3
3-29	82-303-312-01		Cushion, Actuating		2
3-30	82-303-299-01		Spring, Actuating B		2
3-31	82-215-341-01		Steel ball		3
3-32	82-303-303-01		Flange collar idler lever		1
3-33	82-303-337-01		Lever, Play idler B ass'y		1
3-34	82-303-342-01		Lever, Play idler ass'y		1
3-35	82-303-325-01		Spring, Play idler		1
3-36	82-303-272-01		Play idler ass'y		1
3-37	82-303-298-01		Spring, Actuating A		1
3-38	82-304-201-31		Mechanism chassis ass'y		1
3-39	82-304-287-01		Flange collar, Cassette lid	*	1
3-40	82-304-239-01		Lock plate, Cassette lid	*	1
3-41	87-830-504-01		UL tube 5φ x 40		1
3-42	82-304-318-01		Spring, Lock plate	*	1
3-43	82-304-237-01		Slide plate, Eject	*	1
3-44	82-304-241-01		Flange collar, Eject	*	1
3-45	82-304-235-01		Holder, Lead switch	*	1
3-46	82-303-372-01		Felt, Erase head		1
3-47	82-303-290-01		Guide, Cassette lid		1
3-48	82-303-316-01		Spring, Pinch lever		1
3-49	82-303-260-01		Pinch roller ass'y		1
3-50	82-303-301-01		Motor pulley, Flywheel		1
3-51	82-304-701-01		Spacer, Insulation	*	1
3-52	82-304-256-01		Holder, Motor A	*	1
3-53	87-087-029-01		Rubber cushion		3
3-54	87-081-483-01		Motor screw, M2.6		3
3-55	82-304-265-01		Spring, Eject	*	1
3-56	82-304-257-01		Holder, Motor B	*	1
3-57	82-303-367-01		Cushion, Actuating		1
3-58	82-303-382-01		Felt, Brake		1
3-59	82-303-326-01		Spring, Back tension		1

EXPLODED VIEW-4

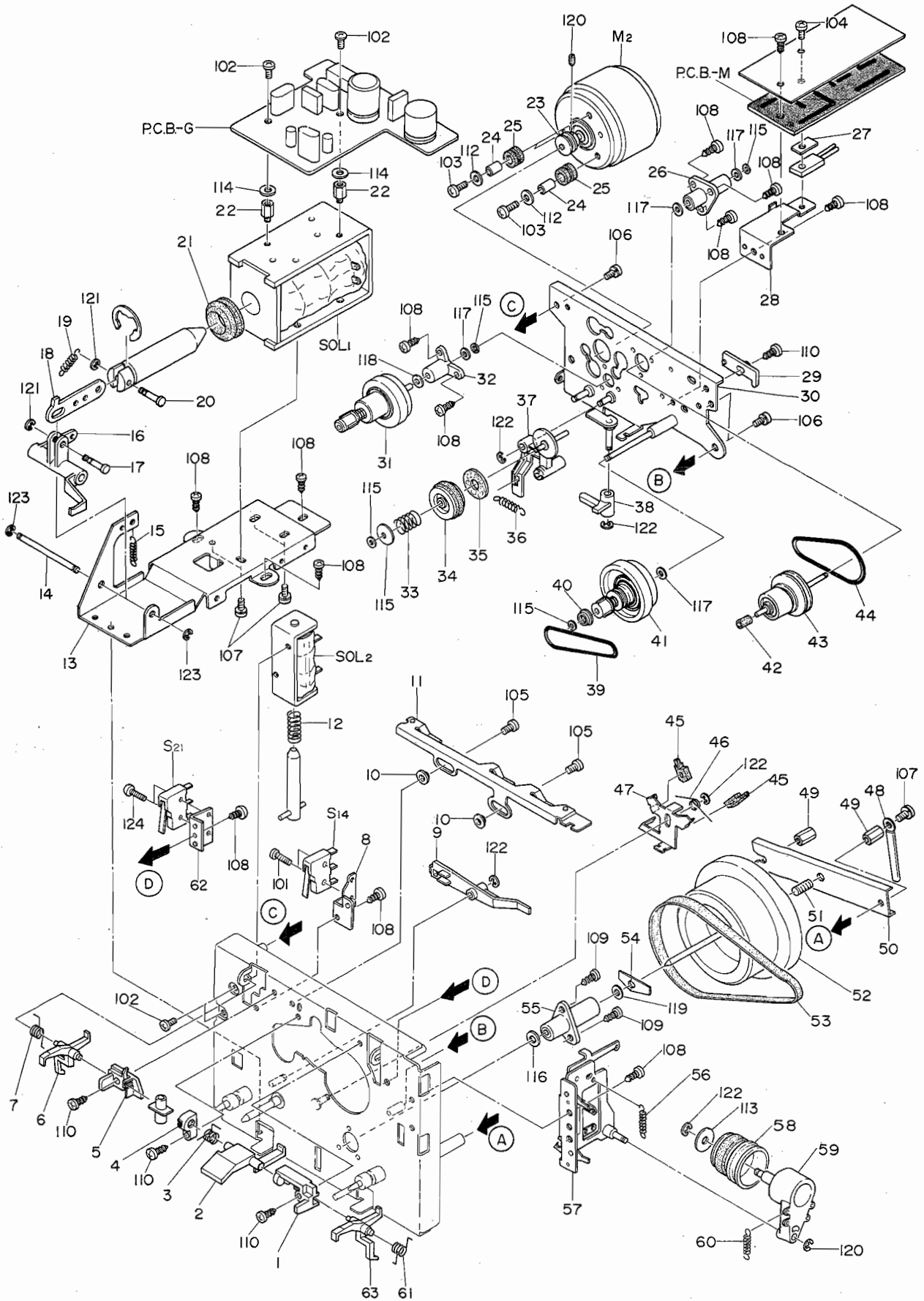

ELECTRICAL MAIN PARTS LIST

Table with columns: Symbol No., Part No., Description. Section: << REC/PB CIRCUIT BOARD SECTION >>. Includes parts like PCB-A, IC1,2, Q1,2, Q3,4, Q5,6,7,8, Q103,104, Q105,106, Q301,303, Q305,306, Q201,202, Q203,251, Q204, Q205, Q206, Q302, Q307,308, Q309,310, Q311,312, Q401-414, D201,203, D202, D204,205, D206,207, D208, D209, D210, D301,302, D304,305, D306,308, D310,401, D402,403, D303, D309, L1,2,3,4, L107,108, L101,102, L103,104, L105,106, LPF101,102, TC251,252, OSC UNIT, RY1, S9, VR7,8,9,10, VR11,12,15, S1,2, S3,4, S5, S6,7,8, SFR1,2,3,4, SFR101,102, SFR251, SFR252, Th1,2, Th3,4, R217, R218, R209, R210, R202, C21,22, C115,116, C35,36, C25,26, C37,38, C17,18, PCB-B, IC1,2, IC3, Q1,2, Q3,4,5,6, Q7,8,12, Q9,10,11,13, D1,2, D3,4,5,6, SFR1,2, SFR3, SFR4, SFR5, SFR6, PIN-1, R92, C49,50, C57,58, C33,34, C53,54.

Table with columns: Symbol No., Part No., Description. Section: << PEAK METER CIRCUIT BOARD SECTION >>. Includes parts like PCB-C, IC1,3,101, IC2, Q1,2, Q3,4, Q5,6,7,8, Q9,10,12, Q11,13,101, D1~8, D9,10,11,12, D41, D101,102, D103,104, D105,106, SFR1,2, SFR3,4, SFR5,6, SFR101,102, Th1,2, PIN-3, PIN, PIN-2, PIN, C5,6, C1,2, C7,8, PCB-D, IC1,2, D1, D2,3, PIN, R9,10, C1,2, C9,10, C11,12, C3,4, C13,14, PCB-E, Q1,2,3,4,5,6,7,8,9,10,11,12,13,14,15,16,17,18,19,20,21,22,23,24,25,26,29,30,31,32,33, D1,2,3,5,6, D4,7,10, PIN-4, PIN-5, PCB-F, Q1,6,9,10,11,12,25,26,27,28,29,30,33,34,35,36,37,38,39,40,41,44,45,46,47,50,51,52,53,54,55,56,57,58,59,60,64,65,66, Q5, Q7,8, Q31,32,42,43,48,49,61,62,63, D1,4,7,8,9,10,11,13,17,20,21,25,26,27, RY1, S18, PIN-6, PIN-7, PIN-8,9, PIN-10.

Table with columns: Symbol No., Part No., Description. Section: << CL CIRCUIT BOARD SECTION >>. Includes parts like PCB-G, Q13,14,15, Q17,19,22, Q16,18,20, D6, D23, R35, PCB-H, VR1,2, VR3,4, PCB-I, VR5,6, PCB-J, J9, PCB-K, D1,6, D2,3,4,5, PCB-N, DME, PCB-O, Q1,2,3, D1, PCB-P, Q1,2,3,4,5,6, PCB-Q, Th1, Th2, PCB-R, F1,3,4, F2, F5, F6, PCB-S, S22,23, S22, F7, F7, F8, C1,2, PCB-T, RY1, S19, J5,6,7,8,10, Q1, D1, T1, T1.

DESCRIPTION

ION >

circuit board

transistor, 2SC945L (Q)

transistor, 2SD234 (Y)

diode, 1S1555

diode, 1S1885

Resistor >

10W Cement resistor

SECTION 2 >

Volume circuit board-2

Volume, 20kΩ-A (MIC CORD LEVEL)

Volume, 50kΩ-A (LINE CORD LEVEL)

SECTION 1 >

Volume circuit board-1

Volume, 10kΩ-A (PUT LEVEL)

Symbol No.	Part No.	Description
RH,PH	82-304-635-11	REC/PB combination head
EH	82-304-636-01	Erase head
D24	87-027-083-01	Diode, 1S1885
M1,PCB-L	82-304-637-11	Main motor, DC-EG
M2,PCB-M	82-304-638-01	Sub motor, DC-EG
LM1,2,3,4	82-387-603-51	Meter (PEAK/VU)
PL3	82-304-718-01	Pilot lamp (CASSETTE WINDOW)
SOL1	82-304-639-01	Plunger (FWD)
SOL2	82-304-640-11	Plunger (FR)
J1,2,3,4	82-304-634-01	Jack ass'y (PHONES, LINE IN, MIC)
J11	87-032-882-01	Jack 2.5φ (PLAYER SYNC)
S10	87-031-408-01	Push switch (POWER)
S11	82-304-723-01	Micro switch (PLAY DETECTION)
S13,14,21	82-304-724-01	Micro switch (CASSETTE DETECTION, ERASE PREVENTION DETECTION, CrO ₂ AUTO)
S15,17	82-304-630-01	Slide switch (TIMER, MEMORY)
S16	87-040-100-01	Counter (MEMORY COUNTER)
S20	82-375-623-01	Slide switch (DIN OUTPUT LEVEL)

Symbol No.	Part No.	Description
CON-1	82-304-703-01	Connector ass'y, 3P
CON-3	82-304-657-11	Connector ass'y, 4P
CON-6	82-304-664-11	Connector ass'y, 4P
CON-13	82-304-668-01	Connector ass'y, 4P
CON-4	82-304-661-11	Connector ass'y, 5P
CON-12	82-304-669-01	Connector ass'y, 5P
CON-2	82-304-659-11	Connector ass'y, 6P
CON-11	82-304-670-01	Connector ass'y, 6P
CON-5,9	82-304-663-11	Connector ass'y, 8P, 10P
CON-7	82-304-666-11	Connector ass'y, 9P
CON-8	82-304-665-11	Connector ass'y, 10P
CON-10	82-304-667-01	Connector ass'y, 14P

⚠ Symbol is used to indicate that a specific component must be replaced only by the component for safety reasons.

CIRCUIT BOARD

Port control jack circuit board

Selector (REMORT CONTROL)

SECTION >

Light emitting diode, 1033 (RED)

Light emitting diode, 303E (GRN)

SECTION >

Circuit board

BOARD SECTION >

Sync circuit board

Resistor, 2SC1815 (Y)

Diode, 1S1555

BOARD SECTION >

Resistor circuit board

Resistor, 1.7kΩ

Resistor, 5kΩ

SECTION >

Circuit board

Transformer, "T" 315mA

Transformer, "T" 315mA

Transformer, "T" 630mA

Transformer, "T" 630mA

Transformer, "T" 1.25A

Transformer, "T" 1.25A

Transformer, "T" 1A

Transformer, "T" 1A

Transformer, "T" 1A

BOARD SECTION >

Selector circuit board

Switch (VOLTAGE CONTROL) (E model only)

Switch (VOLTAGE CONTROL) (K, G model only)

Transformer, "T" 500mA (E model only)

Transformer, "T" 500mA (model only)

Transformer, "T" 315mA (model only)

Transformer, "T" 315mA (model only)

Transformer, "T" 500mA (model only)

Transformer, "T" 500mA (model only)

SECTION >

Circuit board

Resistor, A212N

4P, DIN JACK

4P, LINE IN/PLAY

Resistor, 2SC1634 (7)

Diode, 1S1555

Transformer (model only)

Transformer (model only)

Transformer (model only)

LEVEL DIAGRAM

• **PLAYBACK**

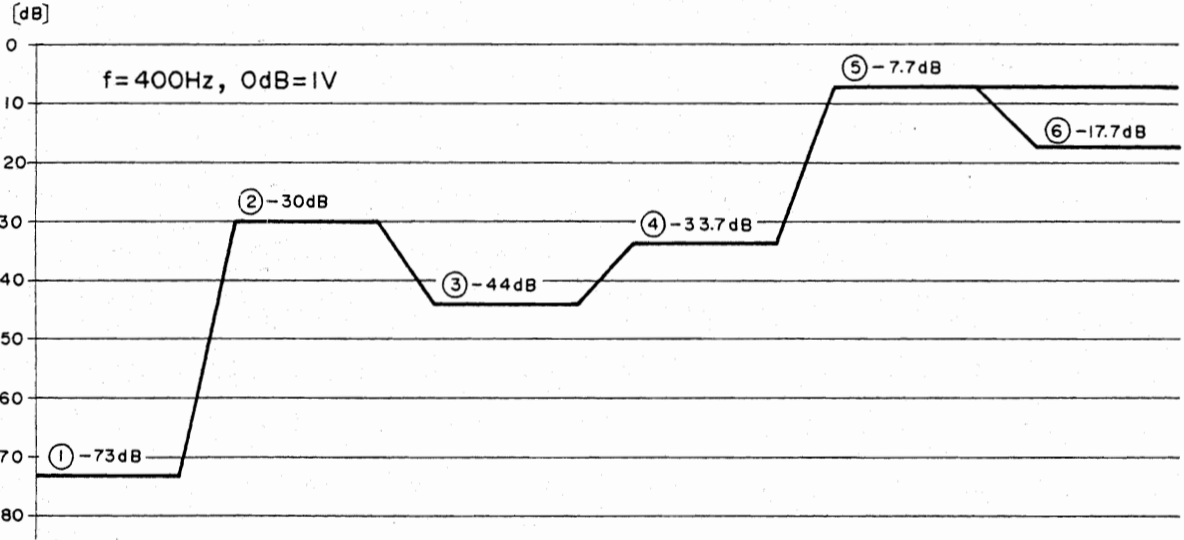
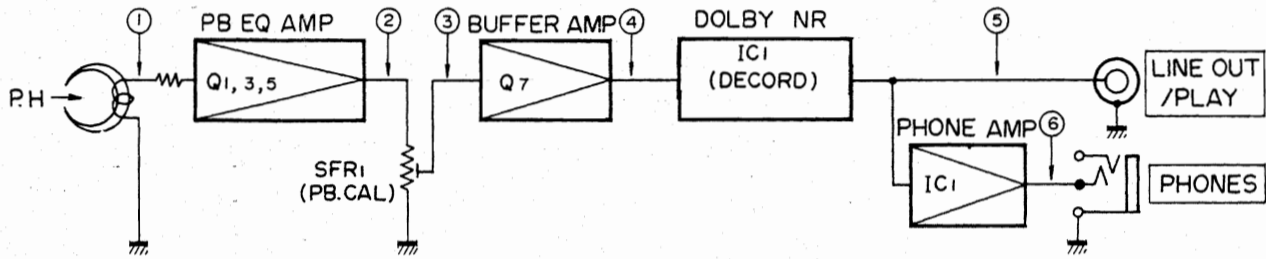

• **RECORD**

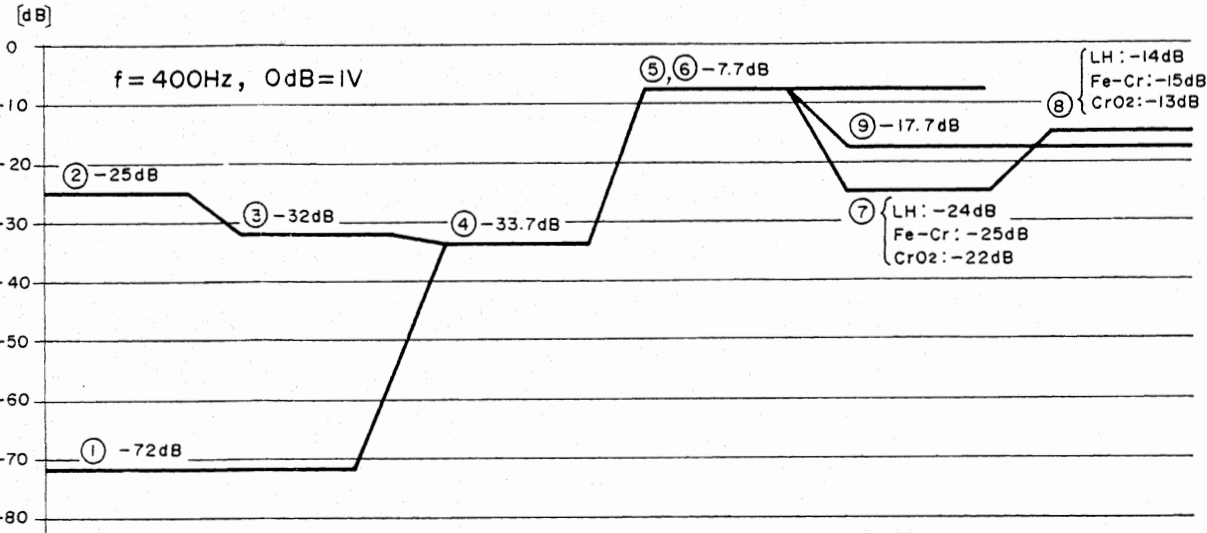
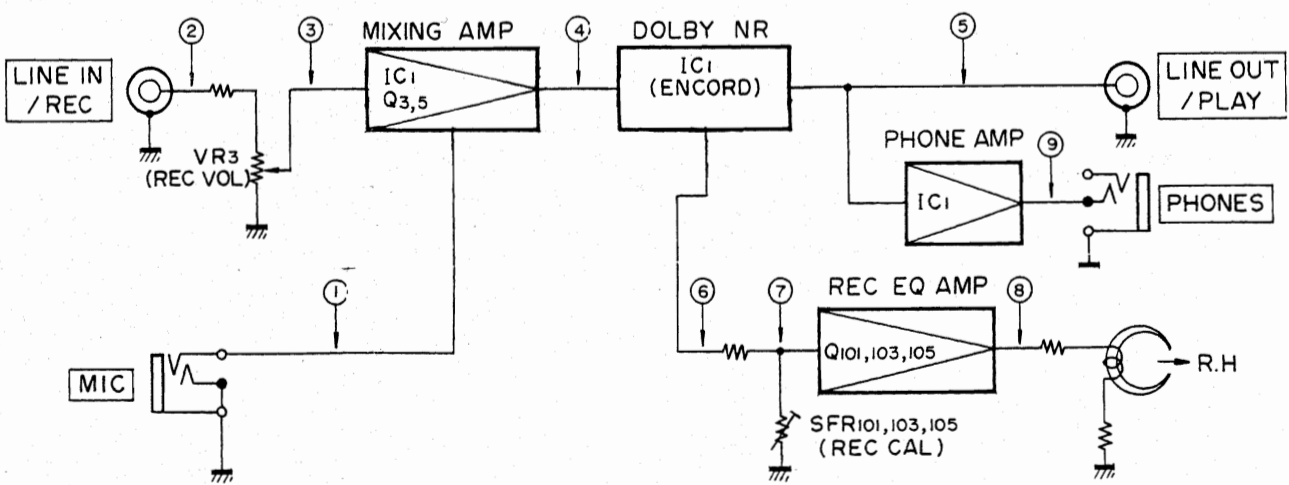

SCHEMATIC DIAGRAM - 1

A B C D E F G H I J K L M N

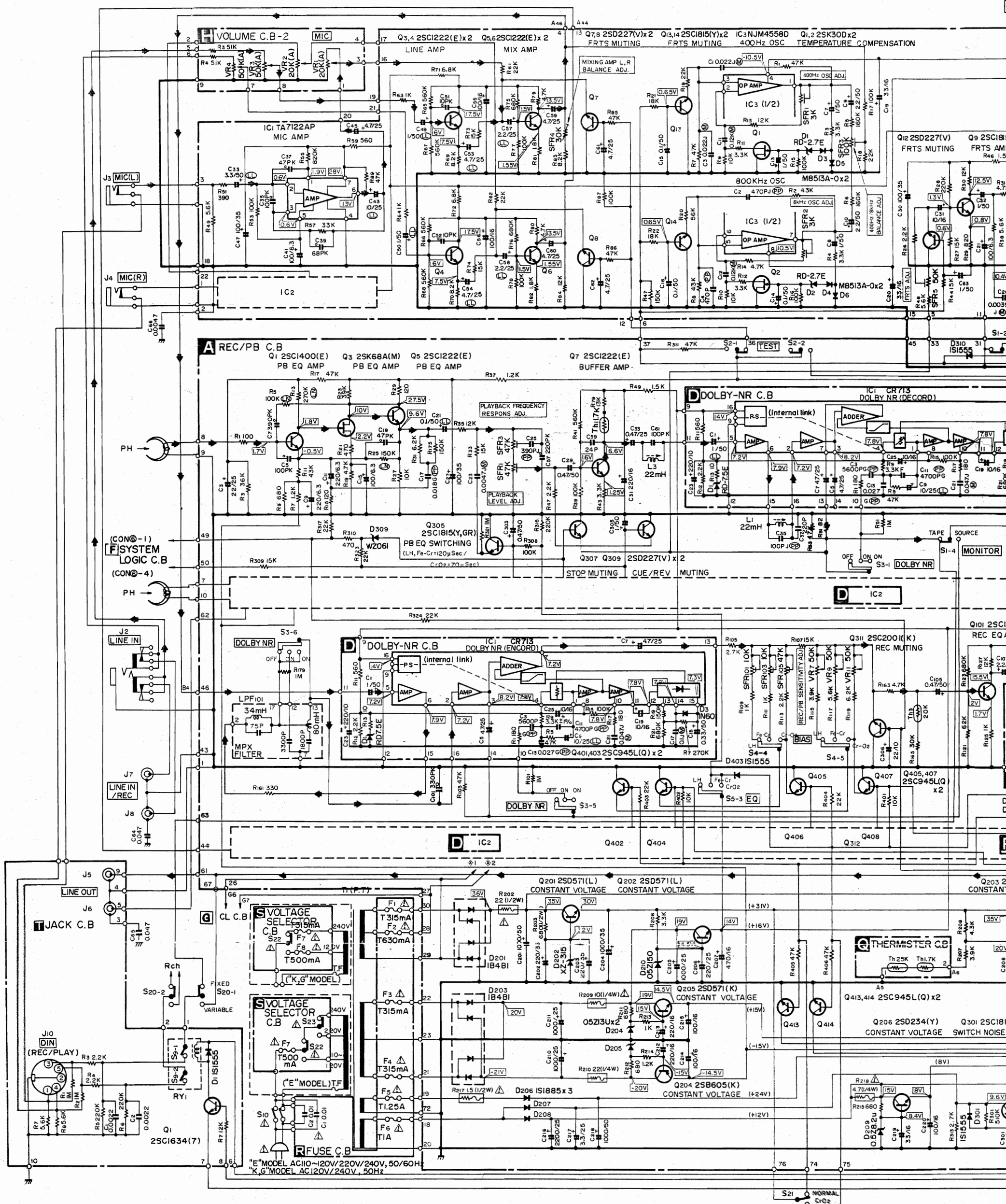

158

12 13 14 15 16 17 18 19 20 21

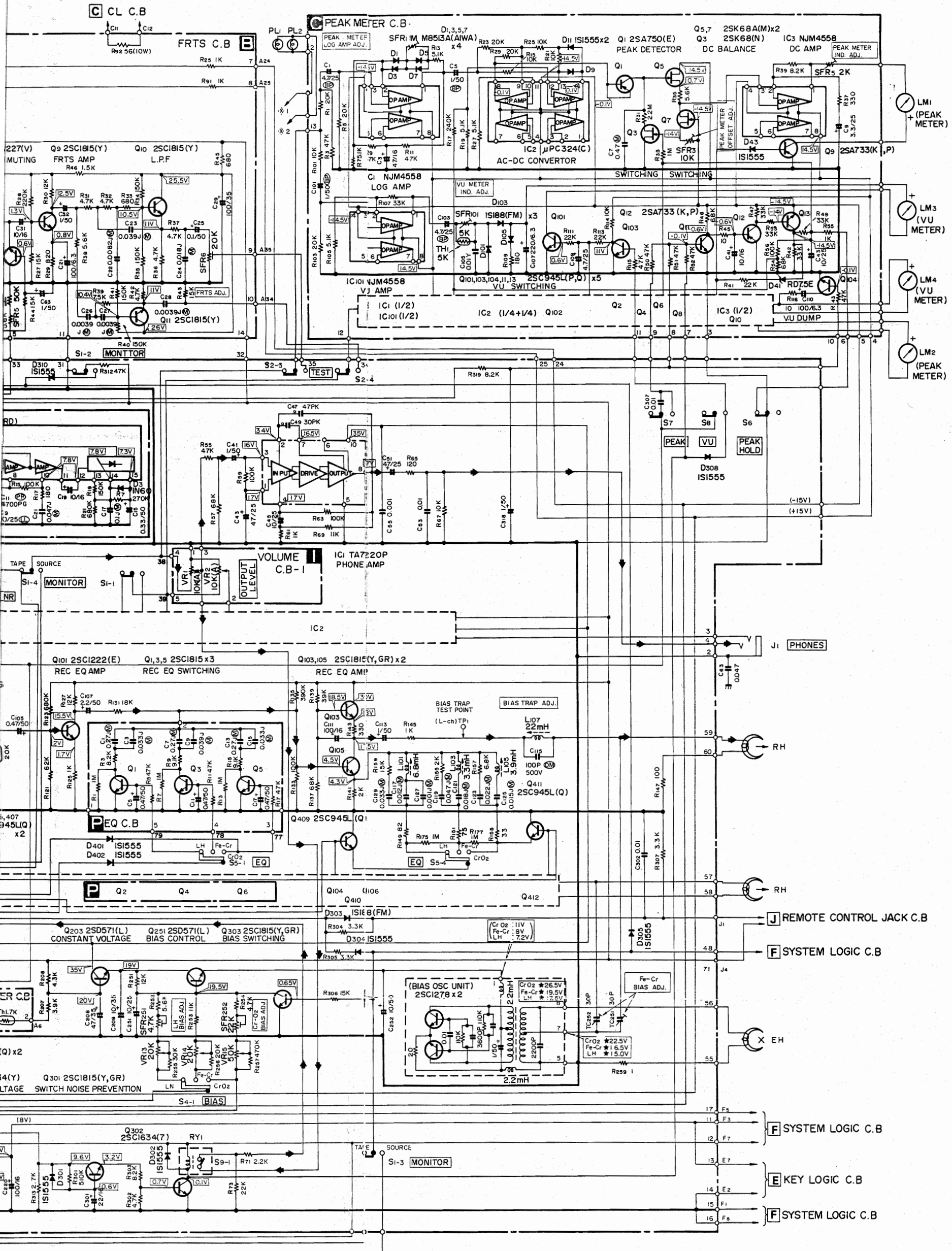

SCHEMATIC DIAGRAM-2

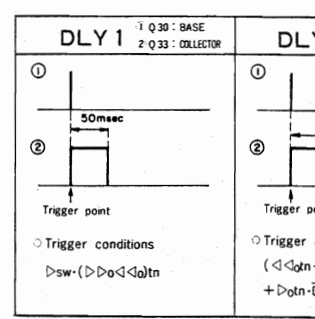
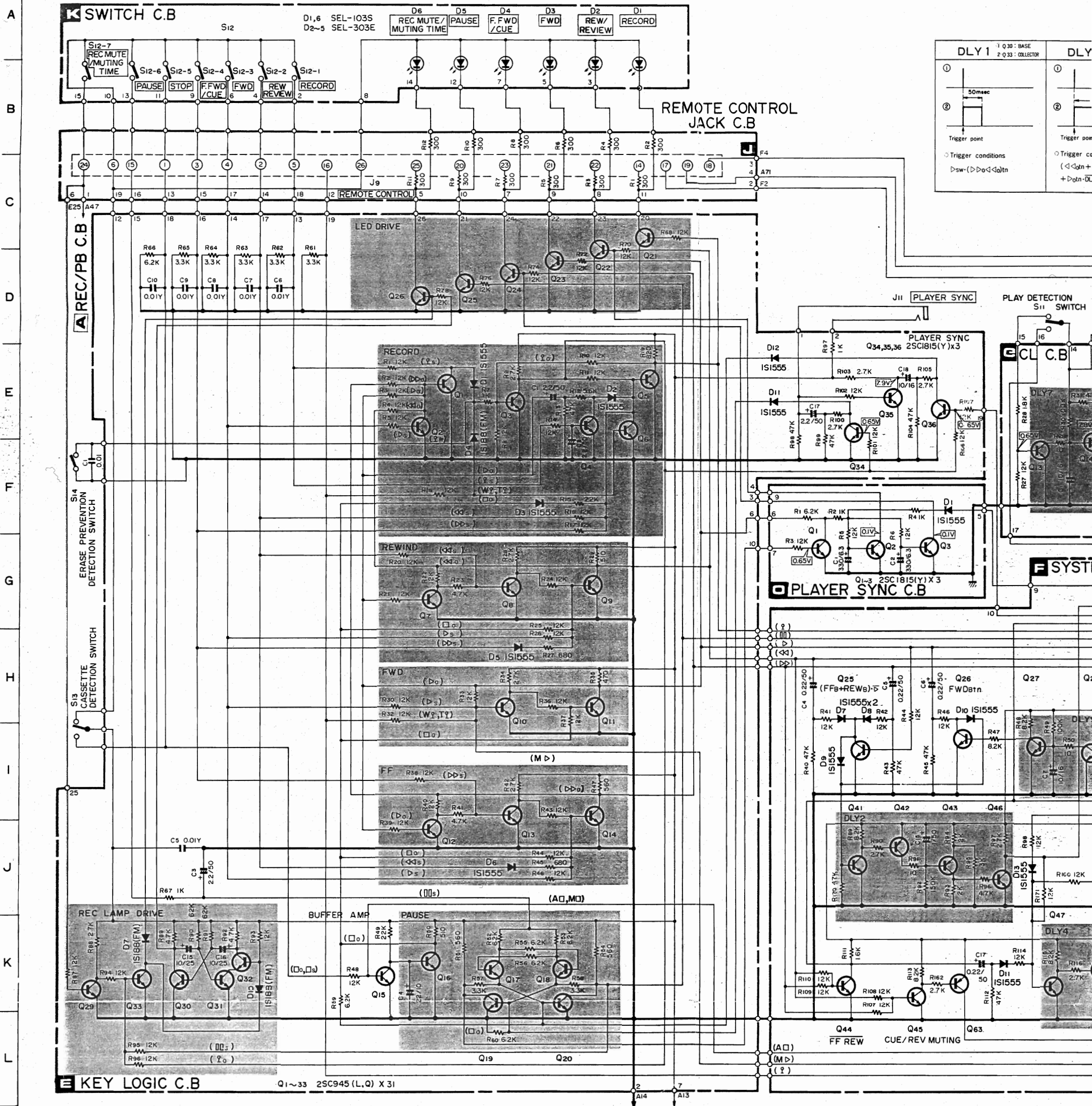

- NOTES:**
- 1) B (+) power supply, — B (-) power supply
 - 2) Signal path
 - 3) The voltage is the reference value measured with a tester (20 k-ohms/V DC) when there are no signals. An asterisk (*) indicates that the value was measured with a vacuum-tube voltmeter during recording.
 - 4) Resistors with no designation have a rated power of 1/4W and a tolerance of ±5%.
 - 5) Capacitors with no designation have a dielectric strength of less than 50WV.
 - 6) Ceramic capacitor symbols:
 - SL For temperature compensation (SL)
 - YY High dielectric constant system (YY)
 - YP, YZ High dielectric constant system (YP, YZ)
 - 7) The only capacitor tolerances indicated are ±2% (G), ±5% (J) and ±10% (K).

- 8) Explanation of symbols:
 - (M) Mylar capacitor
 - (S) Styrol capacitor
 - (BP) Bi-Polar Electrolytic capacitor
 - (LL) Low-leakage capacitor
 - (PP) Polypropylene film capacitor
 - (LN) Low-noise resistor
 - ⚠ Symbol is used to indicate that a specific component must be replaced only by the component for safety reasons.
- 9) Switches are set to the following positions

S1-1~4	MONITOR	(SOURCE)
S2-1~4	TEST	(ON)
S3-1~6	DOLBY-NR	(OFF)
S4-1~6	TAPE SELECTOR-BIAS	(LH)
S5-1~4	TAPE SELECTOR-EQ	(LH)
S6	PEAK HOLD	(OFF)
S7	PEAK	(ON)
S8	VU	(ON)

- | | | |
|---------|----------------------------|---------|
| S9 | STOP MUTING | (STOP) |
| S10 | POWER | (OFF) |
| S11 | PLAY DETECTION | |
| S12-1~7 | LOGICAL CONTROL | |
| S13 | CASSETTE DETECTION | |
| S14 | ERASE PREVENTION DETECTION | |
| S15 | TIMER | (PLAY) |
| S16 | TAPE COUNTER | |
| S17 | MEMORY | (STOP) |
| S18 | SUB MOTOR SELECTOR | |
| S19 | DIN MUTING | |
| S20 | DIN OUTPUT LEVEL | (FIXED) |
| S21 | CrO ₂ AUTO | (OFF) |
| S22 | VOLTAGE SELECTOR-1 | (240V) |
| S23 | VOLTAGE SELECTOR-2 | (240V) |
| | (E MODEL) | |

* This schematic diagram is subject to change without notice in the interests of improved performance.

12 13 14 15 16 17 18 19 20 21

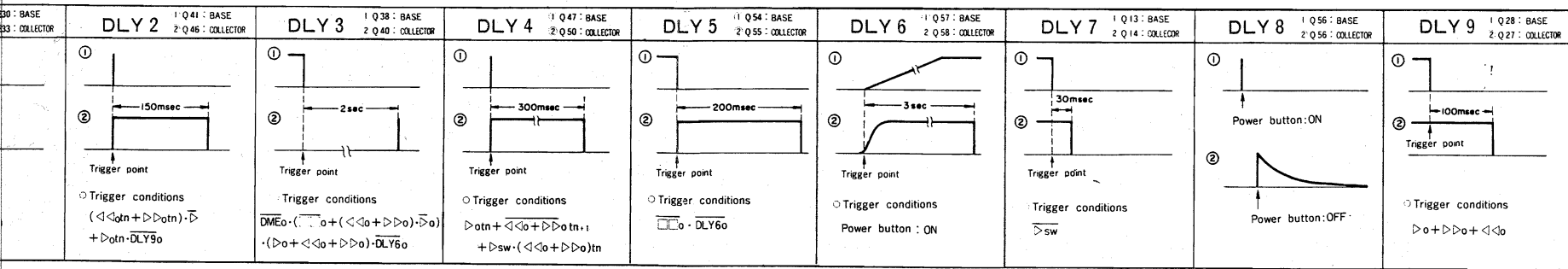

(Symbols: o = output, tn = instant)

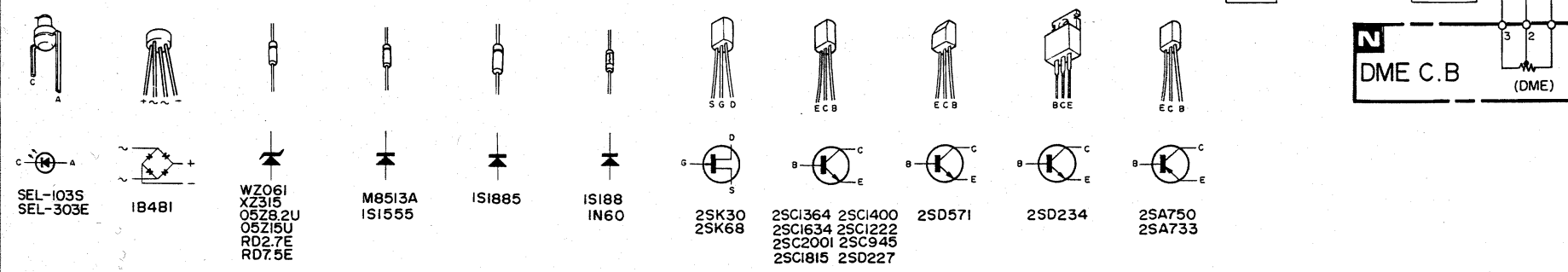
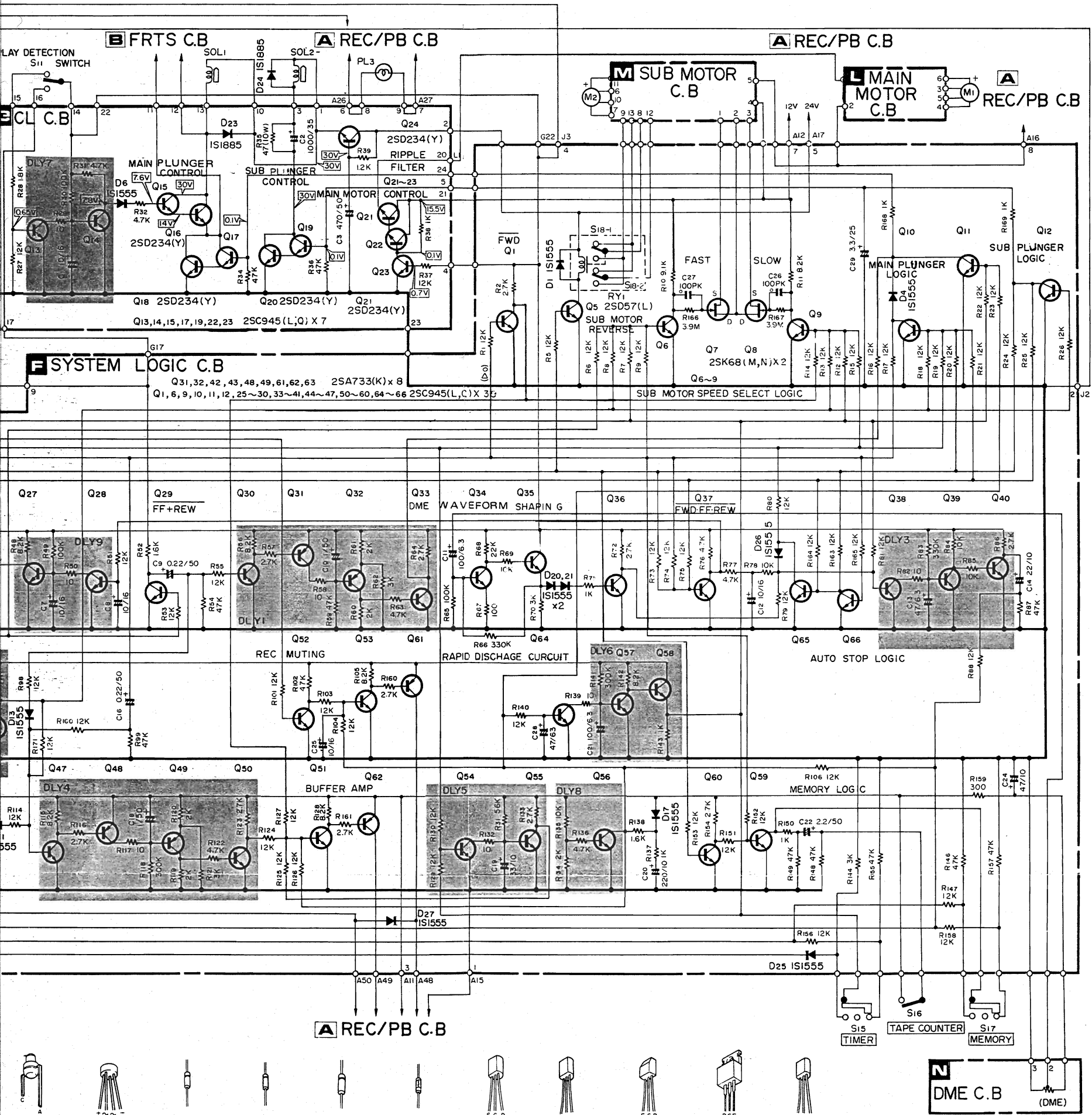

WIRING-1

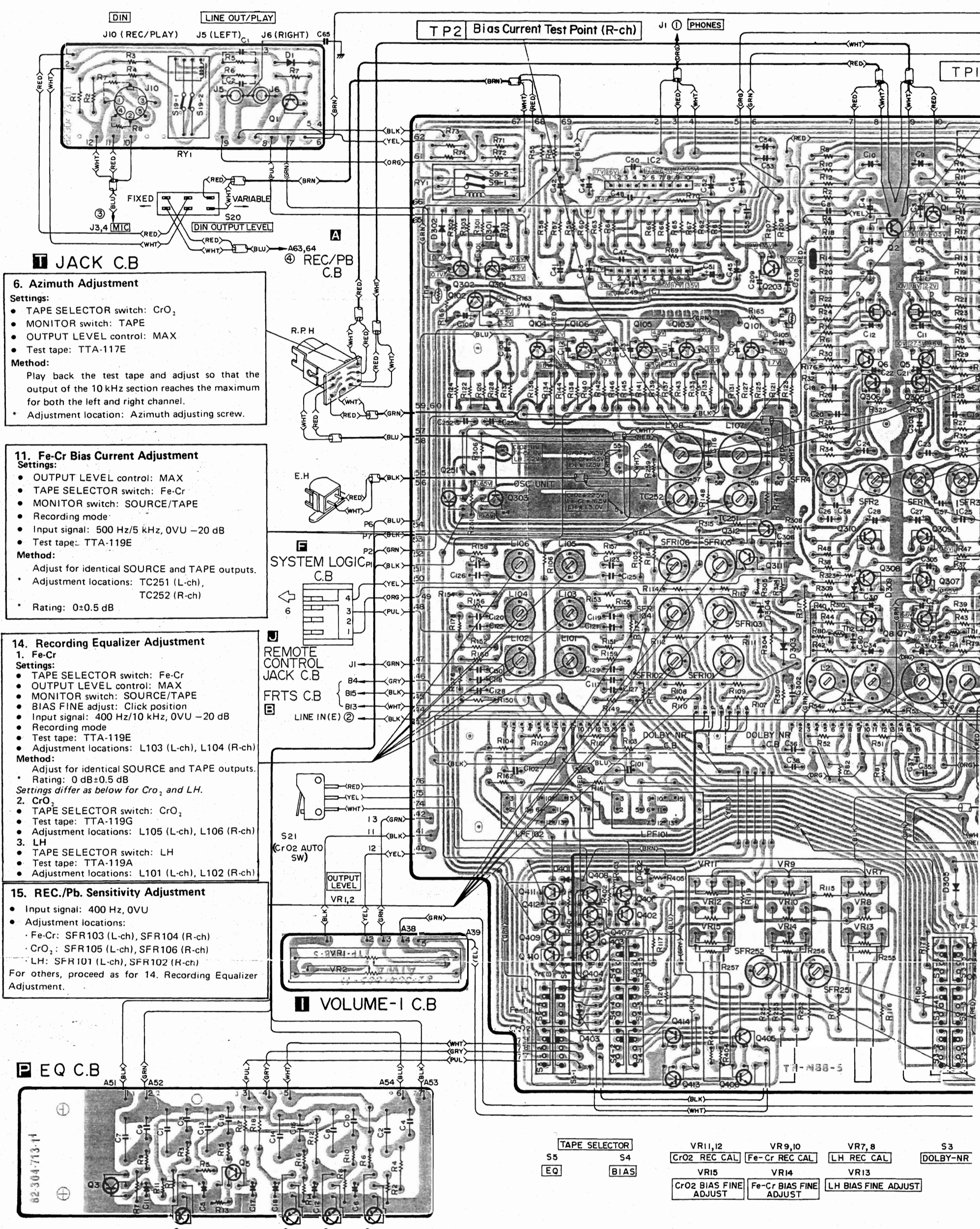

JACK C.B

6. Azimuth Adjustment

Settings:

- TAPE SELECTOR switch: CrO₂
- MONITOR switch: TAPE
- OUTPUT LEVEL control: MAX
- Test tape: TTA-117E

Method:

Play back the test tape and adjust so that the output of the 10 kHz section reaches the maximum for both the left and right channel.

- Adjustment location: Azimuth adjusting screw.

11. Fe-Cr Bias Current Adjustment

Settings:

- OUTPUT LEVEL control: MAX
- TAPE SELECTOR switch: Fe-Cr
- MONITOR switch: SOURCE/TAPE
- Recording mode
- Input signal: 500 Hz/5 kHz, 0VU -20 dB
- Test tape: TTA-119E

Method:

Adjust for identical SOURCE and TAPE outputs.

- Adjustment locations: TC251 (L-ch), TC252 (R-ch)
- Rating: 0±0.5 dB

14. Recording Equalizer Adjustment

1. Fe-Cr

Settings:

- TAPE SELECTOR switch: Fe-Cr
- OUTPUT LEVEL control: MAX
- MONITOR switch: SOURCE/TAPE
- BIAS FINE adjust: Click position
- Input signal: 400 Hz/10 kHz, 0VU -20 dB
- Recording mode
- Test tape: TTA-119E
- Adjustment locations: L103 (L-ch), L104 (R-ch)

Method:

Adjust for identical SOURCE and TAPE outputs.

- Rating: 0 dB±0.5 dB

Settings differ as below for CrO₂ and LH.

2. CrO₂

- TAPE SELECTOR switch: CrO₂
- Test tape: TTA-119G
- Adjustment locations: L105 (L-ch), L106 (R-ch)

3. LH

- TAPE SELECTOR switch: LH
- Test tape: TTA-119A
- Adjustment locations: L101 (L-ch), L102 (R-ch)

15. REC./Pb. Sensitivity Adjustment

- Input signal: 400 Hz, 0VU
- Adjustment locations:
 - Fe-Cr: SFR103 (L-ch), SFR104 (R-ch)
 - CrO₂: SFR105 (L-ch), SFR106 (R-ch)
 - LH: SFR101 (L-ch), SFR102 (R-ch)

For others, proceed as for 14. Recording Equalizer Adjustment.

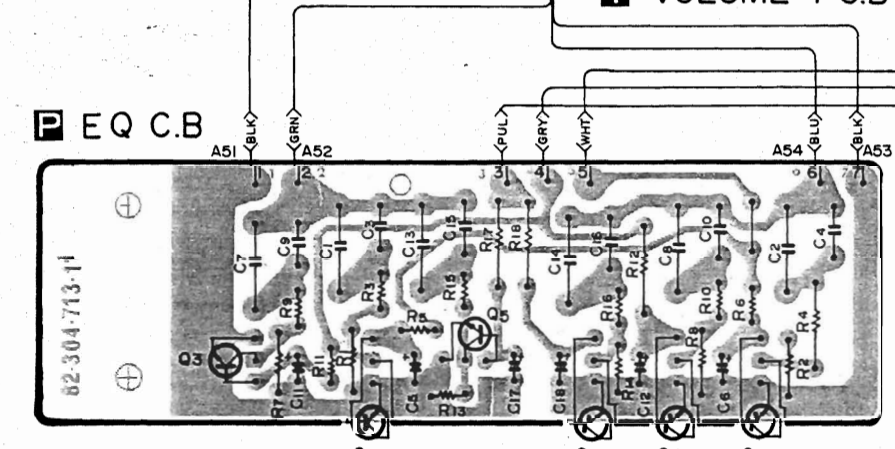

NOTES (1) B(+) Pattern Component side pattern Others pattern (2) The voltage is the reference value measured with a tester (20

12 13 14 15 16 17 18 19 20 21

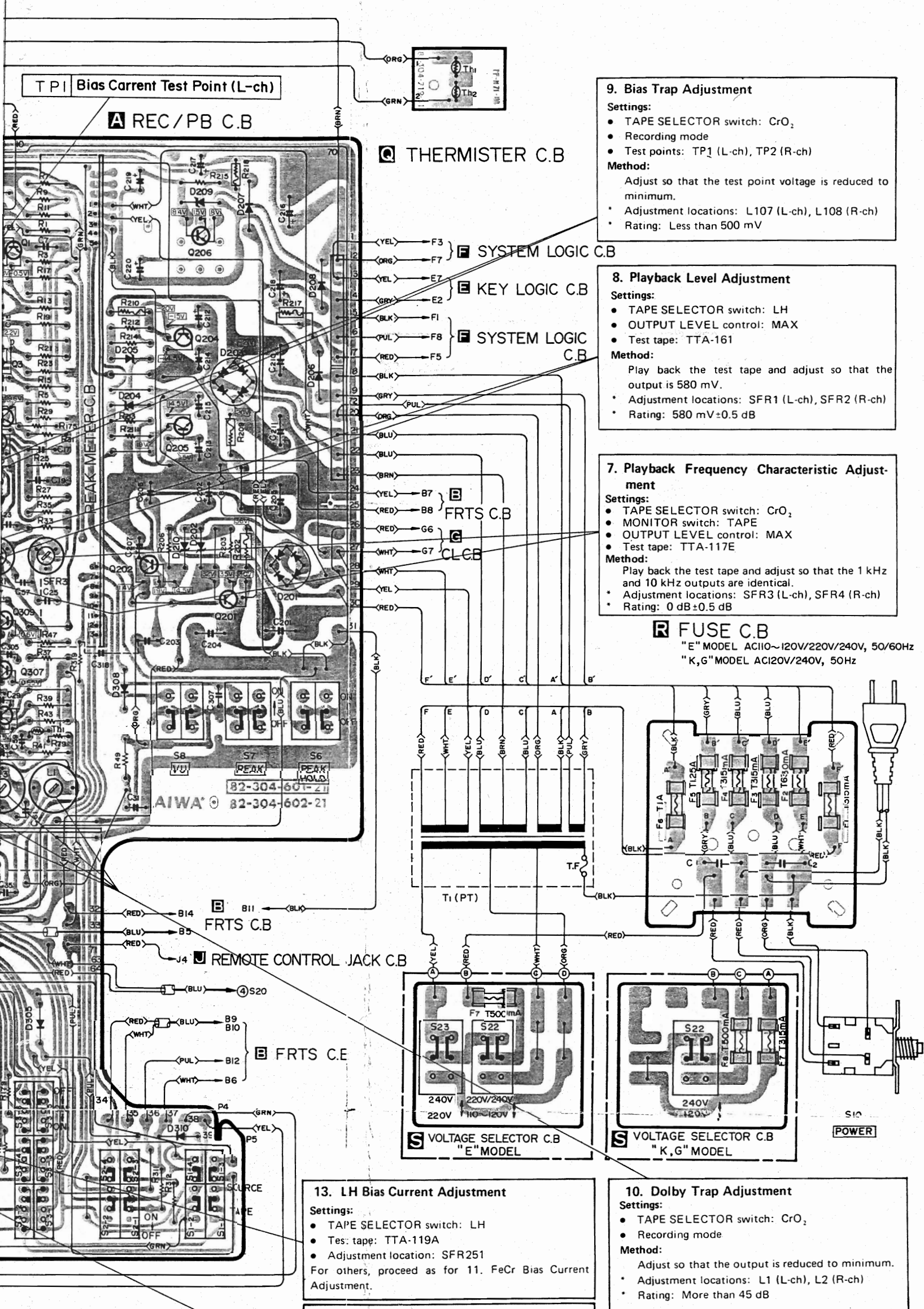

TP1 Bias Current Test Point (L-ch)

A REC/PB C.B

Q THERMISTER C.B

F SYSTEM LOGIC C.B

E KEY LOGIC C.B

F SYSTEM LOGIC C.B

B FRTS C.B

C CLCB

R FUSE C.B

"E" MODEL AC110~120V/220V/240V, 50/60Hz
"K,G" MODEL AC120V/240V, 50Hz

E B11

FRTS C.B

J4 REMOTE CONTROL JACK C.B

B FRTS C.E

S VOLTAGE SELECTOR C.B "E" MODEL

S VOLTAGE SELECTOR C.B "K,G" MODEL

13. LH Bias Current Adjustment

Settings:

- TAPE SELECTOR switch: LH
- Test tape: TTA-119A
- Adjustment location: SFR251

For others, proceed as for 11. FeCr Bias Current Adjustment.

12. CrO₂ Bias Current Adjustment

Settings:

- TAPE SELECTOR switch: CrO₂
- Test tape: TTA-119G
- Adjustment location: SFR252

For others, proceed as for 11. FeCr Bias Current Adjustment.

9. Bias Trap Adjustment

Settings:

- TAPE SELECTOR switch: CrO₂
- Recording mode
- Test points: TP1 (L-ch), TP2 (R-ch)

Method:

Adjust so that the test point voltage is reduced to minimum.

- Adjustment locations: L107 (L-ch), L108 (R-ch)
- Rating: Less than 500 mV

8. Playback Level Adjustment

Settings:

- TAPE SELECTOR switch: LH
- OUTPUT LEVEL control: MAX
- Test tape: TTA-161

Method:

Play back the test tape and adjust so that the output is 580 mV.

- Adjustment locations: SFR1 (L-ch), SFR2 (R-ch)
- Rating: 580 mV ± 0.5 dB

7. Playback Frequency Characteristic Adjustment

Settings:

- TAPE SELECTOR switch: CrO₂
- MONITOR switch: TAPE
- OUTPUT LEVEL control: MAX
- Test tape: TTA-117E

Method:

Play back the test tape and adjust so that the 1 kHz and 10 kHz outputs are identical.

- Adjustment locations: SFR3 (L-ch), SFR4 (R-ch)
- Rating: 0 dB ± 0.5 dB

10. Dolby Trap Adjustment

Settings:

- TAPE SELECTOR switch: CrO₂
- Recording mode

Method:

Adjust so that the output is reduced to minimum.

- Adjustment locations: L1 (L-ch), L2 (R-ch)
- Rating: More than 45 dB

tester (20K ohms/VDC) when there are no signals.

1 2 3 4 5 6 7 8 9 10 11 12

WIRING-3

A B C D E F G H I J K L N

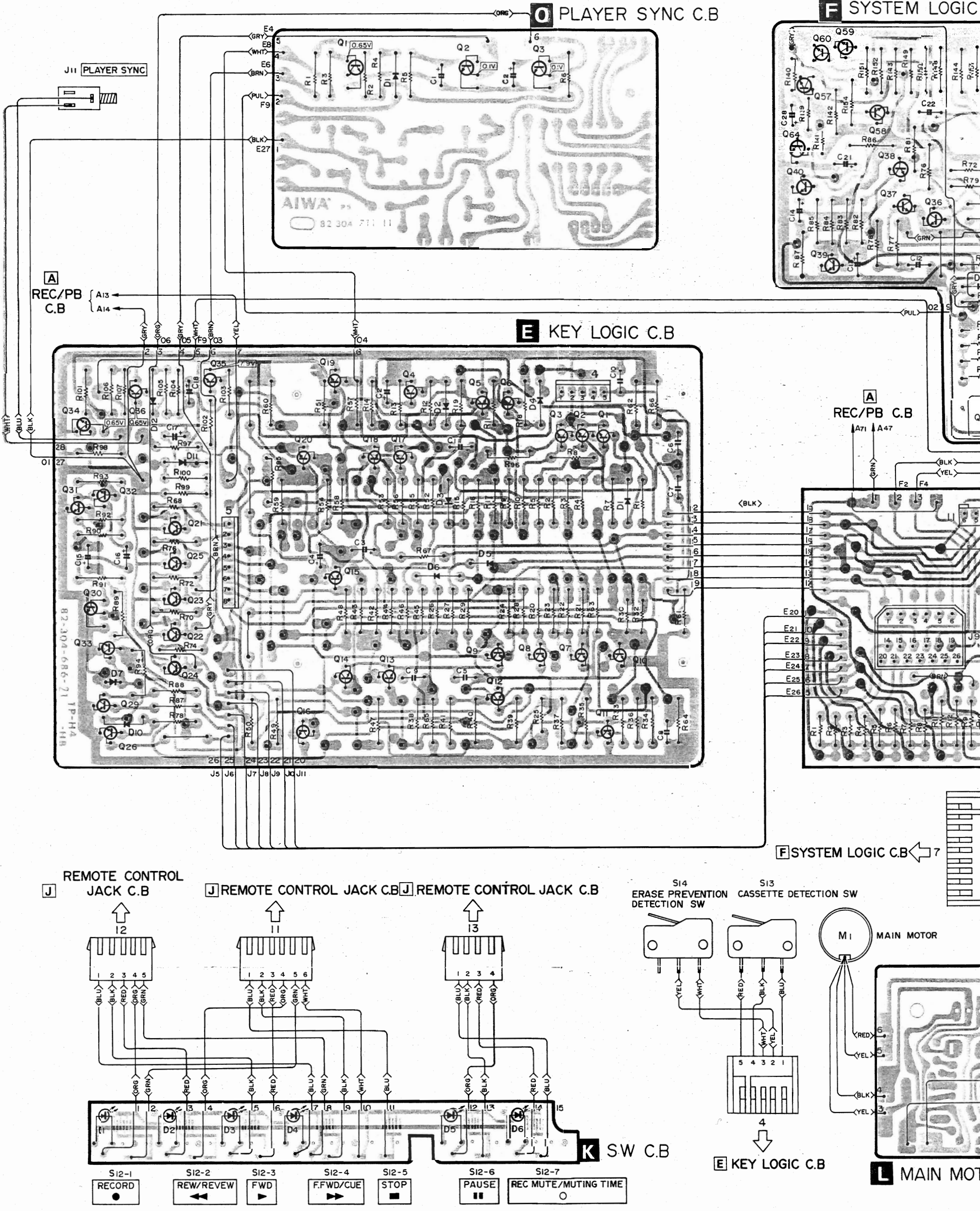

NOTES (1) B(+) Pattern Component side pattern Others pattern (2) The voltage is the reference value measured with a tester

SYSTEM LOGIC C.B

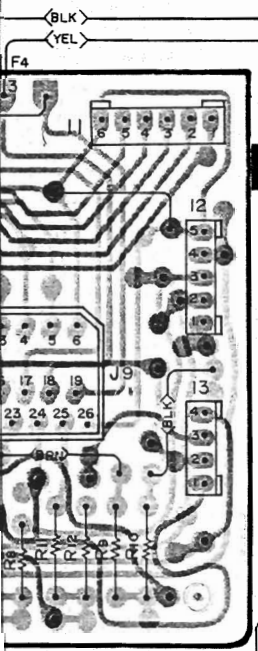
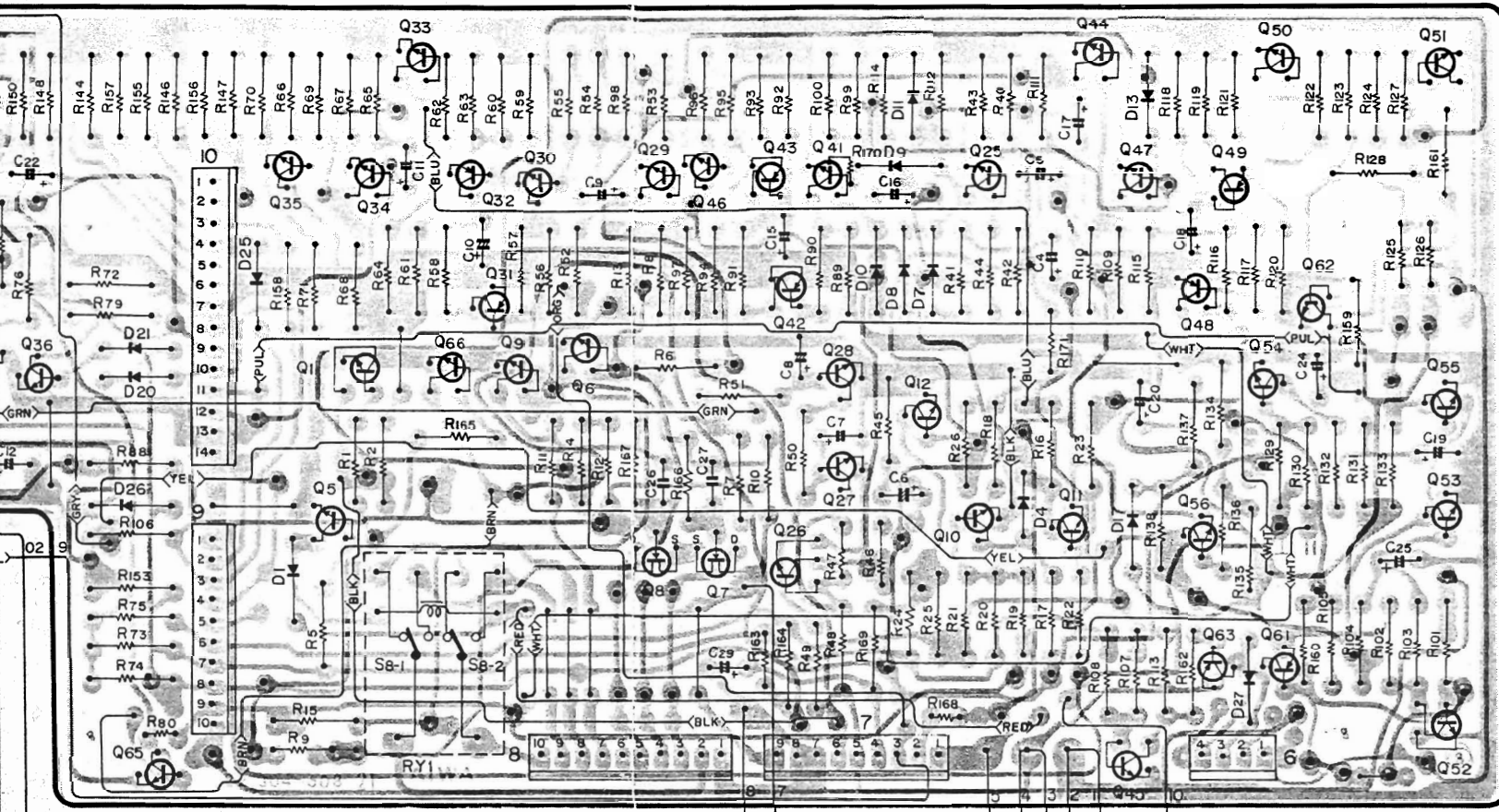

J REMOTE CONTROL JACK C.B

E KEY LOGIC C.B

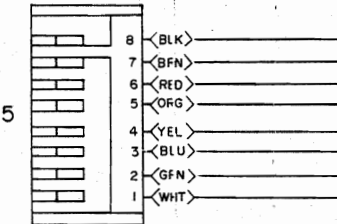

SOL2 SUB PLUNGER

A REC/PB C.B

F SYSTEM LOGIC C.B

A REC/PB C.B

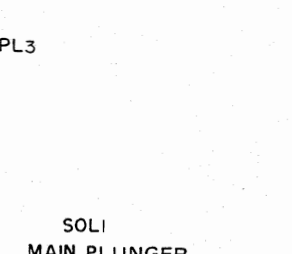

SOL1 MAIN PLUNGER

B FRTS C.B

S11 PLAY DETECTION SW

G CL C.B

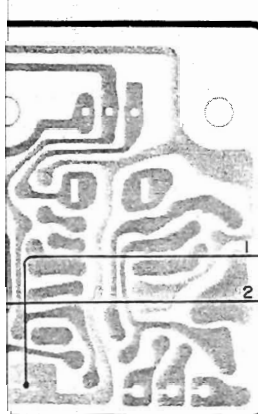
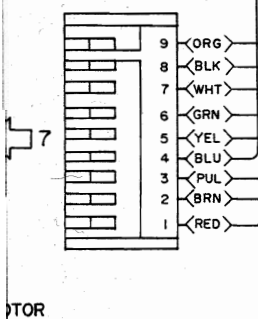

MAIN MOTOR C.B

with a tester (20K ohms/VDC) when there are no signals.

198

1 2 3 4 5 6 7 8 9 10 11

WIRING-2

4. Peak Meter Indication Adjustment

Settings:

- MONITOR switch: SOURCE
- OUTPUT LEVEL control: MAX
- Input signal: 400 Hz, 0VU
- Recording mode

Method:

- Adjust so that peak meter indication is 0 dB.
- Adjustment locations: SFR5 (L-ch), SFR6 (R-ch)
- Rating: 0 dB±0.5 dB

3. Peak Meter Offset Adjustment

Settings:

- PEAK HOLD switch: OFF
- OUTPUT LEVEL control: MIN

Method:

- Adjust so that peak meter pointer does not deflect with PEAK switch ON/OFF.
- Adjustment locations: SFR3 (L-ch), SFR4 (R-ch)

2. VU Meter Indication Adjustment

Settings:

- MONITOR switch: SOURCE
- OUTPUT LEVEL control: MAX
- Input signal: 400 Hz -16 dB (1V = 0 dB)
- Recording mode

Method:

- Rotate LINE RECORD LEVEL for an output of 410mV.
- Adjust so that VU meter indication is 0VU.
- Adjustment locations: SFR101 (L-ch), SFR102 (R-ch)
- Rating: 0VU±0.5 dB

1. Mixing Amp. Balance Adjustment

Settings:

- MONITOR switch: SOURCE
- OUTPUT LEVEL control: MAX
- Input signal: 400 Hz, 0VU
- Recording mode

Method:

- Adjust so that output is same for left and right channels.
- Adjustment location: SFR4
- Rating: Within 0.5 dB

C PEAK METER C.B

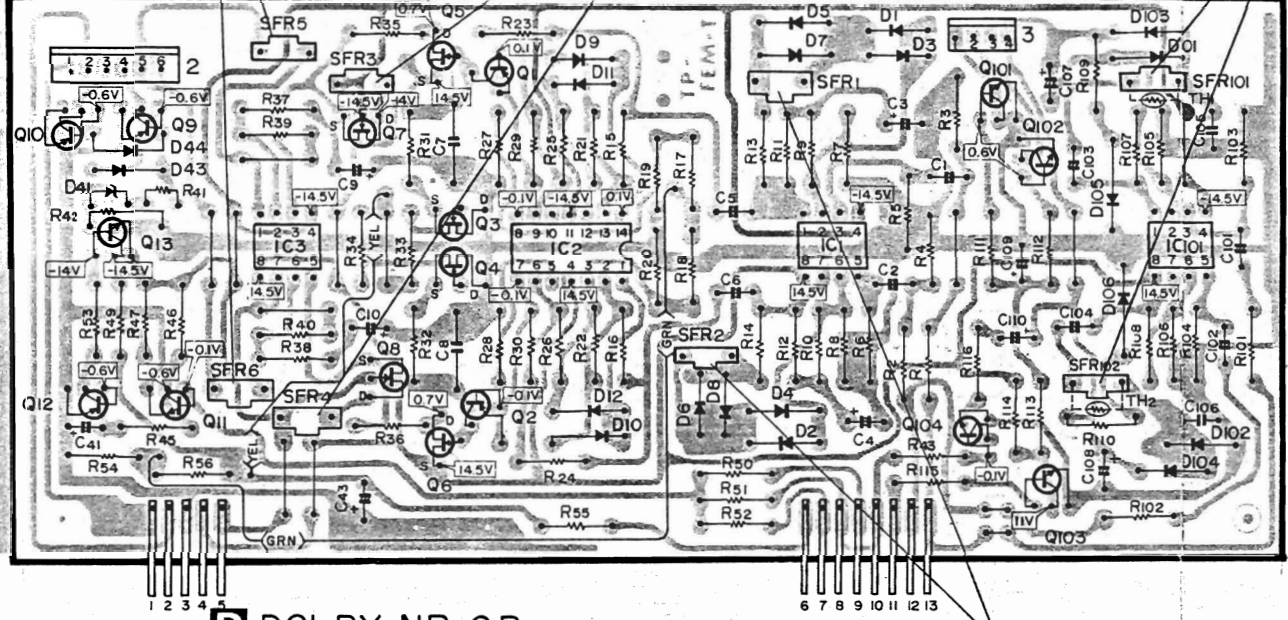

D DOLBY-NR C.B

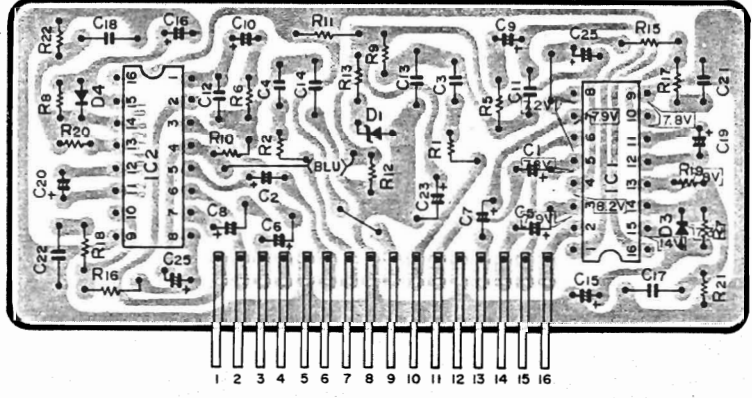

5. Peak Meter Log. Amp. Adjustment

Settings:

- MONITOR switch: SOURCE
- OUTPUT LEVEL control: MAX
- Input signal: 400 Hz, 0VU
- Recording mode

Method:

- Adjust for a peak meter indication of -30 dB when the input is reduced by 17 dB.
- Adjustment locations: SFR1 (L-ch), SFR2 (R-ch)
- Rating: -30 dB±1 dB

B FRTS C.B

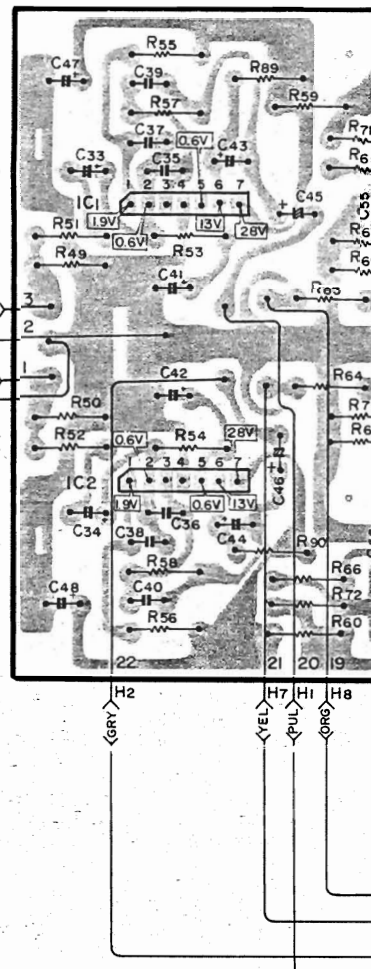

M SUB MOTOR C.B

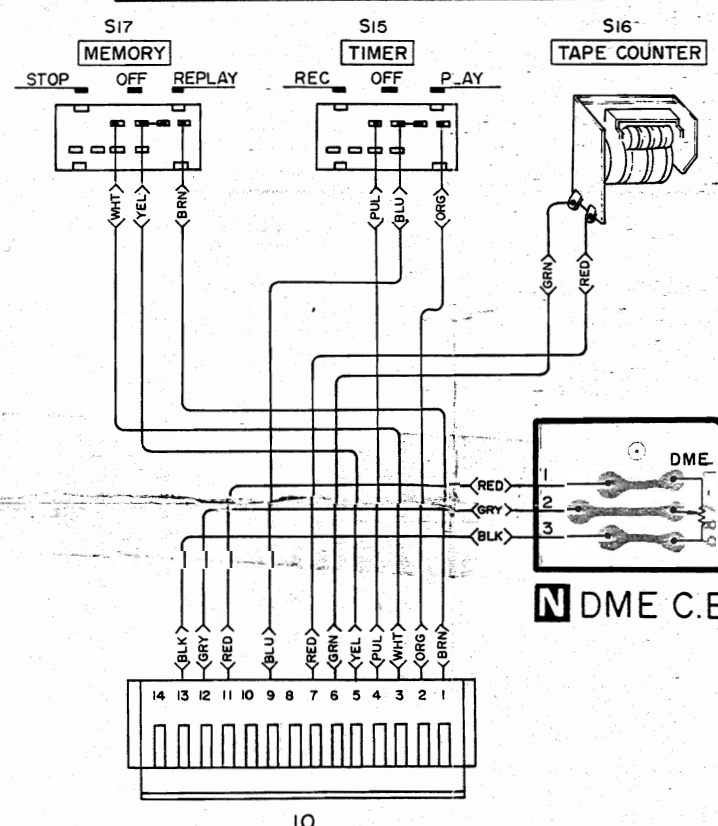
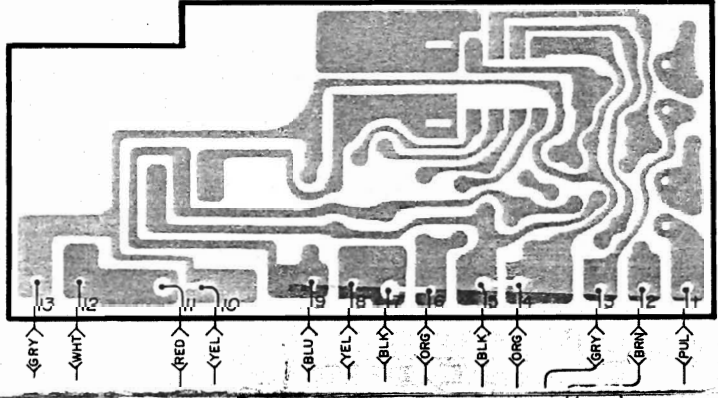

F SYSTEM LOGIC C.B

F SYSTEM LOGIC C.B

A REC/PB C.B

Balance Adjustment
 SOURCE
 control: MAX
 Hz, 0VU
 output is same for both left
 s.
 on: SFR4
 5 dB

19. FRTS Adjustment
Settings:
 • Recording mode
 • OUTPUT LEVEL control: MAX
 • Input signal: 400 Hz/8 kHz, 0VU -20 dB
 • Test tape: TTA-119E
Method:
 Using the test tape, check the frequency response of the 400 Hz and 8 kHz input signals, and adjust so that right channel meter indication is 0VU when the TEST switch is set to ON.
 Now adjust as follows for the left channel meter.
 0 dB : 0VU
 -1 dB : +1VU
 +1 dB : -1VU
 Adjustment locations: SFR5 (L-ch), SFR6 (R-ch)

16. 400 Hz Osc Adjustment
Settings:
 • Recording mode
 • OUTPUT LEVEL control: MAX
 • TEST switch: ON
Method:
 Adjust so that waveforms appear on the oscilloscope.
 Connect the oscilloscope to the right channel.
 Adjustment location: SFR1

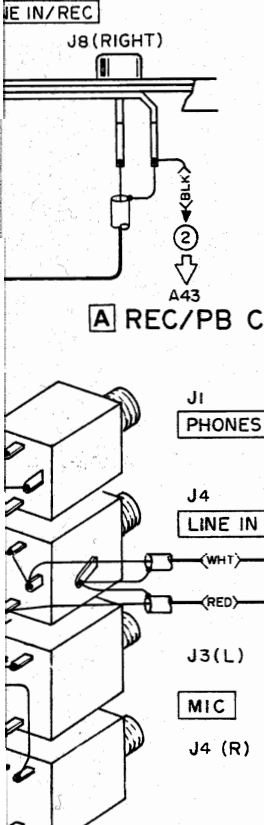
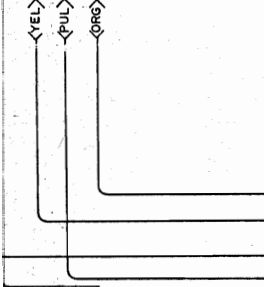
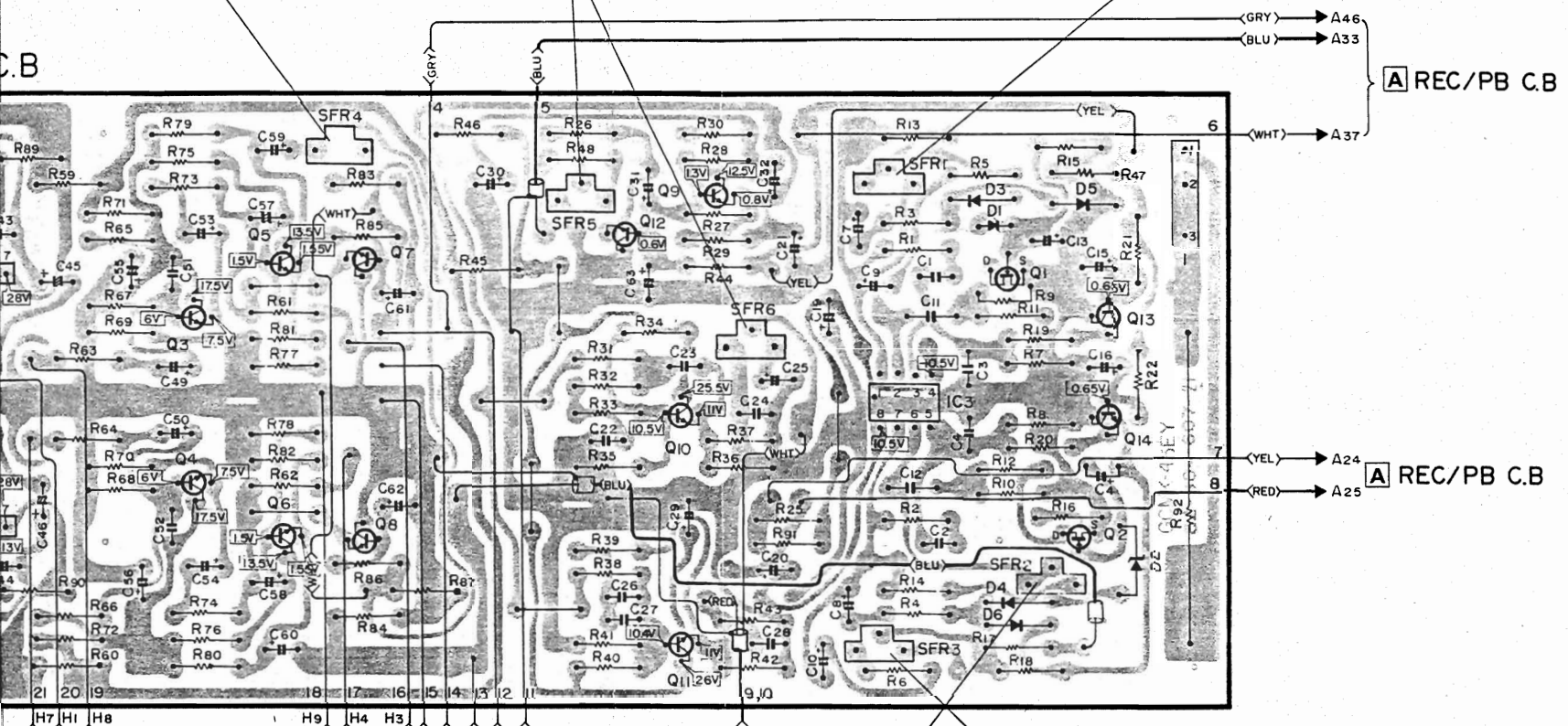

17. 8 kHz Osc Adjustment
 Adjustment location: SFR2
 For others, proceed as for 16. 400 Hz Osc Adjustment.

18. 400 Hz/8 kHz Balance Adjustment
Settings:
 • Recording mode
 • OUTPUT LEVEL control: MAX
 • TEST switch: ON
Method:
 Adjust so that the arrows of the oscillation waveforms appear on the same lines.
 Adjustment location: SFR3

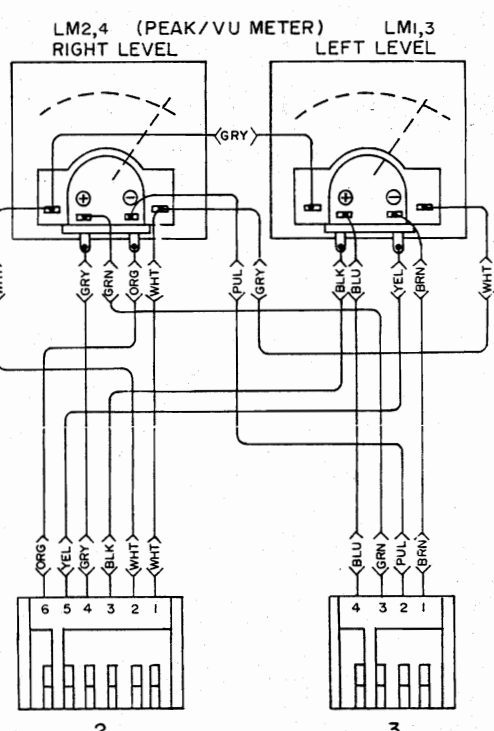
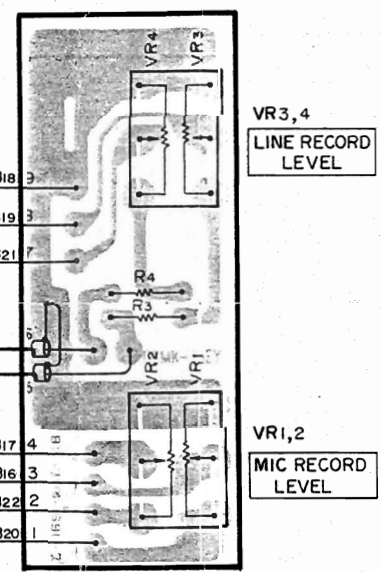
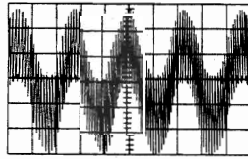

H VOLUME-2 C.B

C PEAK METER C.B C

red with a tester (20K ohms/DVC) when there are no signals.

Ref. No.	Part No.	Part No. Changed to	Description	Common Model	Q'ty
4-1	82-303-285-01		Guide, Cassette R		1
4-2	82-303-347-01		Lever, Cassette pressure		1
4-3	82-303-355-01		Spring, Cassette pressure		1
4-4	82-303-348-01		Holder, Cassette pressure		1
4-5	82-303-289-01		Guide, Cassette L		1
4-6	82-303-346-01		Lever, Rec.-blocking		1
4-7	82-303-354-01		Spring, Rec.-blocking		1
4-8	82-303-350-01		Holder, Rec.-blocking		1
4-9	82-303-286-01		Lever, Brake		1
4-10	82-304-286-01		Flange collar B		2
4-11	82-304-238-01		Slide lever, Cassette pressure	*	1
4-12	82-481-311-01		Spring, Plunger		1
4-13	82-304-233-01		Holder, Plunger	*	1
4-14	82-304-244-01		Shaft, Play lever	*	1
4-15	82-304-248-01		Spring, Plunger	*	1
4-16	82-304-232-01		Lever, PLAY	*	1
4-17	82-304-243-01		Shaft B, Plunger	*	1
4-18	82-304-234-01		Slide plate, PLAY	*	1
4-19	82-304-249-01		Spring, Actuating	*	1
4-20	82-304-242-01		Shaft A, Plunger	*	1
4-21	82-304-283-01		Cushion, Plunger	*	1
4-22	82-304-307-01		Screw, Plunger	*	2
4-23	82-303-300-01		FR motor pulley		1
4-24	87-085-135-01		Bushing 3-4-5		3
4-25	87-087-029-01		Rubber cushion		3
4-26	82-303-340-01		Shaft bearing ass'y		1
4-27	82-304-701-01		Spacer, Insulation	*	1
4-28	82-303-259-01		Holder, Motor circuit board		1
4-29	82-304-260-01		Guide, Lock plate	*	1
4-30	82-303-233-01		Mechanism chassis sub ass'y		1
4-31	82-303-360-01		Supply reel platform ass'y		1
4-32	82-303-358-01		Shaft bearing ass'y		1
4-33	82-303-322-01		Spring, FR idler		1
4-34	82-303-271-01		FR idler pulley ass'y		1
4-35	82-303-335-01		Felt 6.4-14		1
4-36	82-303-352-01		Spring, FR lever		1
4-37	82-303-277-01		FR lever ass'y		1
4-38	82-303-292-01		FR eject lever		1
4-39	82-304-247-01		Rubber belt, Counter	*	1
4-40	82-392-352-01		Cap, Take-up reel platform	AD-6550	1
4-41	82-303-249-01		Take-up reel platform ass'y		1
4-42	82-303-309-01		Rubber, Main drive		1
4-43	82-303-330-01		Slip pulley ass'y		1
4-44	82-303-385-01		Rubber belt B, FR		1
4-45	82-439-426-01		Brake shoe A		2
4-46	82-303-318-01		Spring, Brake		1
4-47	82-303-297-01		Slide plate, Brake		1
4-48	87-038-039-01		Wire binder		1
4-49	82-303-314-01		Nut 2.6		2
4-50	82-303-291-01		Plate, Flywheel		1
4-51	82-385-311-01		Screw for thrust	AD-6300	1
4-52	82-303-246-01		Flywheel ass'y		1
4-53	82-303-310-01		Rubber belt, Flywheel		1
4-54	82-303-224-01		Spring, Flywheel		1
4-55	82-392-256-01		Shaft bearing ass'y	AD-6550	1
4-56	82-304-251-01		Spring, Lock lever	*	1
4-57	82-304-221-01		Lock lever ass'y	*	1
4-58	82-397-354-01		Drum wheel C ass'y	AD-6550	1
4-59	82-304-312-01		Idler oil E ass'y	*	1
4-60	82-304-250-01		Spring, Oil	*	1
4-61	82-303-356-01		Spring, CrO ₂		1
4-62	82-303-351-01		Holder, CrO ₂		1
4-63	82-303-349-01		Lever, CrO ₂		1

Ref. No.	Part No.	Description	Q'ty
1-101	87-257-169-11	U + 4-6(Black)	6
1-102	87-233-072-01	Q + 2.6-5	6
1-103	87-081-480-01	VTT + 2.6-5	8

Ref. No.	Part No.	Description	Q'ty
1-104	87-081-504-01	VTT + 2.6-10	2
1-105	87-081-481-01	VTT + 3-5	4
1-106	87-347-094-01	UT ₂ + 3-6(Black)	1

Ref. No.	Part No.	Description	Q'ty
2-101	87-261-072-21	V + 2.6-5	3
2-102	87-261-093-21	V + 3-5	2
2-103	87-253-034-01	U + 2-5	1
2-104	87-251-072-21	U + 2.6-5	21
2-105	87-257-073-01	U + 2.6-6(Black)	3
2-106	87-491-074-01	VWS + 2.6-8	4
2-107	87-233-033-01	Q + 2-4	4
2-108	87-233-034-01	Q + 2-5	2
2-109	87-081-480-01	Q + 2.6-5	2
2-110	87-231-094-21	Q + 3-6	10
2-111	87-342-033-01	UT ₂ + 2-4(Black)	2
2-112	87-081-480-01	VTT + 2.6-5	15

Ref. No.	Part No.	Description	Q'ty
2-113	87-510-074-01	VTT ₂ + 2.6-8	5
2-114	87-081-522-01	QTT + 2.6-6	4
2-115	87-540-073-01	Special screw + 2.6-6	6
2-116	87-410-326-01	W4-10-1	1
2-117	87-081-015-01	FW3-8-0.5	1
2-118	87-432-907-01	WTE4.5	1
2-119	87-433-906-01	WTE4-9	1
2-120	87-391-034-01	N-4	1
2-121	87-081-481-01	VTT + 3-5	1
2-122	87-261-101-01	V + 3-18	2
2-123	87-251-094-21	U + 3-6	2

Ref. No.	Part No.	Description	Q'ty
3-101	87-253-035-01	V + 2-6	2
3-102	87-253-033-01	U + 2-4	3
3-103	87-253-035-01	U + 2-6	1
3-104	87-251-036-21	U + 2-8	4
3-105	87-251-072-21	U + 2.6-5	2
3-106	87-233-072-01	Q + 2.6-5	2
3-107	87-231-075-21	Q + 2.6-10	1
3-108	87-081-480-01	VTT + 2.6-5	10
3-109	87-081-501-01	VTT + 2.6-6	2
3-110	87-322-035-21	QT ₂ + 2-6	4

Ref. No.	Part No.	Description	Q'ty
3-111	87-410-304-01	W2-6-0.3	2
3-112	87-081-808-01	PW1.7-3.5-0.25	1
3-113	87-081-036-01	TW2-5-0.2	1
3-114	87-371-033-01	SS2-4	2
3-115	87-441-003-01	STE1.5	2
3-116	87-441-009-01	STE3	1
3-117	87-441-006-01	STE2.3	3
3-118	87-391-006-01	N-2	2
3-119	87-237-072-01	Q + 2.6-5(Black)	1

Ref. No.	Part No.	Description	Q'ty
4-101	87-251-036-21	V + 2-8	2
4-102	87-261-072-21	V + 2.6-5	4
4-103	87-171-074-21	V + 2.6-8	3
4-104	87-251-037-21	U + 2-10	1
4-105	87-251-071-21	U + 2.6-4	2
4-106	87-480-072-01	VS + 2.6-5	3
4-107	87-480-094-01	VS + 3-6	5
4-108	87-081-480-01	VTT + 2.6-5	15
4-109	87-081-501-01	VTT + 2.6-6	3
4-110	87-081-502-01	VTT + 2.6-8	4
4-111	82-303-328-01	W2-9.8-0.3	1
4-112	87-410-216-01	W3-8-0.8	3

Ref. No.	Part No.	Description	Q'ty
4-113	87-410-318-01	W3-13-0.8	1
4-114	87-081-031-01	FW3-8-0.5	2
4-115	87-081-808-01	PW1.7-3.5-0.25	4
4-116	82-416-358-01	PW6-2.5-0.5	1
4-117	87-081-036-01	TW2-5-0.2	4
4-118	87-081-319-01	TW2.3-8-0.2	1
4-119	87-081-031-01	TW3-8-0.3	1
4-120	87-371-033-01	SS2-4	1
4-121	87-441-005-01	STE2	2
4-122	87-441-006-01	STE2.3	6
4-123	87-441-009-01	STE3	2
4-124	87-251-036-21	U + 2-8	2

ACCESSORIES/PACKAGE

Ref. No.	Part No.	Part No. Changed to	Description	Common Model	Q'ty
1	82-304-854-01		Printed indiv., Packing	*	1
2	82-304-852-01		Cushion L, Printed indiv.	*	1
3	82-304-853-01		Cushion R, Printed indiv.	*	1
4	87-051-135-01		Poly-vinyl sack (for AC power cord)		1
5	87-056-564-01		Curly stopper		2
6	87-056-607-01		Poly-vinyl sack (for case)		1
7	82-304-905-01		Instructions booklet (E model only)	*	1
8	82-304-906-01		Instructions booklet (K model only)	*	1
9	82-304-907-01		Instructions booklet (G model only)	*	1
10	87-051-175-01		Poly-tube A		1
11	87-056-008-01		Label AC power cord (K model only)		1
12	87-056-009-01		Distributors list		1
13	87-056-014-01		Tag, Main voltage (K model only)		1
14	87-056-032-01		Guarantee card (G model only)		1
15	80-291-645-01		Tape cassette, DMC-130A		1
16	82-304-951-01		Driver	*	1
17	86-925-006-01		Connection cord CW-115KS (E, K model only)		1
18	86-944-619-01		Connection cord CW-129KS (G model only)		2
19	87-058-023-01		Cord binder		1
20	87-058-024-01		Head cleaning pole ass'y		1