

SERVICE MANUAL

STEREO CASSETTE DECK

MODEL NO.

AD-F660

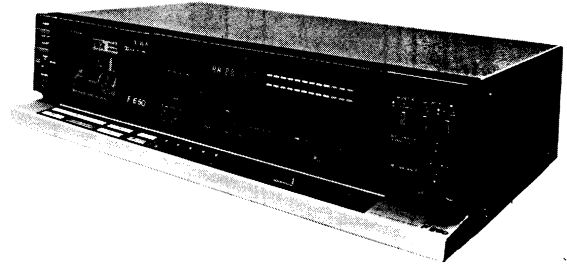

TYPE.

H, HU, U, C, E, K, G, Z

SPECIFICATIONS

Semiconductors:	17 ICs, 78 transistors, 29 diodes, 46 LED's	(WTD-A)	More than 62/68 dB (METAL, DOLBY NR B-type/C-type)
Power supply:	H, HU models AC 120V/220V/240V switchable 50/60 Hz U, C models AC 120V, 60 Hz E, Z models AC 220V, 50/60 Hz K, G models AC 240V, 50/60 Hz		H, HU, U, C, E, K, G models More than 62/68 dB (CrO ₂ , DOLBY NR B-type/C-type) Z model More than 56/52 dB (CrO ₂ , DOLBY NR B-type/C-type) More than 60/66 dB (LH, DOLBY NR B-type/C-type) More than 30 dB
Power consumption:	26W	Channel separation:	(1 kHz, 0VU)
Dimensions:	420(W) x 110(H) x 280(D) mm [16-1/2" x 4-3/8" x 11-1/4"]	Cross talk:	More than 60 dB (1 kHz, 0VU)
Weight:	5.5 kg (12.11 lbs.)	Erasing ratio:	More than 60 dB (125 Hz, 0VU + 10dB, METAL)
Track type:	4 tracks 2 channel	Level drift:	± 0.5 dB (10kHz)
Tape speed:	4.8 cm/s (1-7/8 ips)	Level indication error:	± 1.5 dB (400 Hz, 0 dB)
Wow an flutter:	Less than 0.028% (WRMS) According to DIN 45500 0.09%	ADMS time:	2.0 ± 0.5s. (POWER ON) (ADMS LED light up time)
Automatic stop system:	Full auto stop	Bias frequency:	85 kHz
Automatic shut-off action time:	3 ± 1s.	Frequency response:	METAL 20 ~ 20,000 Hz CrO ₂ 20 ~ 19,000 Hz LH 20 ~ 18,000 Hz
Pinch roller pressure:	T side: 350 ± 30 g (3.43 ± 0.29N) S side: 165 ± 15 g (1.61 ± 0.15N)	DOLBY-NR Effect:	More than 8 dB (10kHz, CCIR FILTER) (DOLBY NR B-type) More than 16 dB (DOLBY NR C-type)
Take-up torque:	38 ± 10 g-cm (0.37 ± 0.11 mN·m)	Motor:	DC Servomotor for capstan DC motor for reels
FF & rewind torque:	150 ⁺⁴⁰ ₋₃₀ g-cm (1.47 ^{+0.39} _{-0.29} mN·m)	Head:	DX Combination head (for Rec/Pb)
FF & rewind time:	60 ± 10s. (C-60)	Inputs:	MIC maximum input sensitivity: 0.3mV (200Ω - 10kΩ matched) LINE IN maximum input sensitivity: 50mV (more than 50kΩ)
Counter indication error:	0 ± 3(C-60)	Outputs:	LINE OUT standard output level: 0.41 V (0VU); suitable load impedance: more than 50kΩ; Headphones: 8Ω
Cassette lid action time:	0.8 ± 0.4s. (at normal temperature)	Test tape:	METAL TTA-119MX LH TTA-119J H, HU, U, C, E, K, G models CrO ₂ TTA-119G Z model CrO ₂ TTA-119D Co TTA-119G
Playback output:	540 ± 30mV (TTA-161)		
Playback noise:	Less than 1.3mV (CrO ₂ DOLBY NR B ON) Less than 2.0mV (METAL DOLBY NR OFF) Less than 2.7mV (LH DOLBY NR OFF)		
Rec./Pb output:	380 ± 30mV (1 kHz, 0VU)		
Rec./Pb distortion:	H, HU, U, C, E, K, G models Less than 1.5% (METAL) Less than 1.5% (CrO ₂) Less than 1.5% (LH) Z model Less than 2.5% (CrO ₂) More than 51/54 dB (METAL, DOLBY NR B-type OFF/ON)		
Rec./Pb SN ratio:	H, HU, U, C, E, K, G models More than 51/54 dB (CrO ₂ , DOLBY NR B-type OFF/ON) Z model More than 44/48 dB (CrO ₂ , DOLBY NR OFF/ON) More than 49/52 (LH, DOLBY NR B-type OFF/ON)		

- Specifications and external appearance are subject to change without due to product improvement.
- Noise reduction system manufactured under license from Dolby Laboratories Licensing Corporation.
- Dolby and the  symbol are trademarks of Dolby laboratories Licensing Corporation.
- HX professional originated by BANG & OLFSEN.

DESCRIPTION

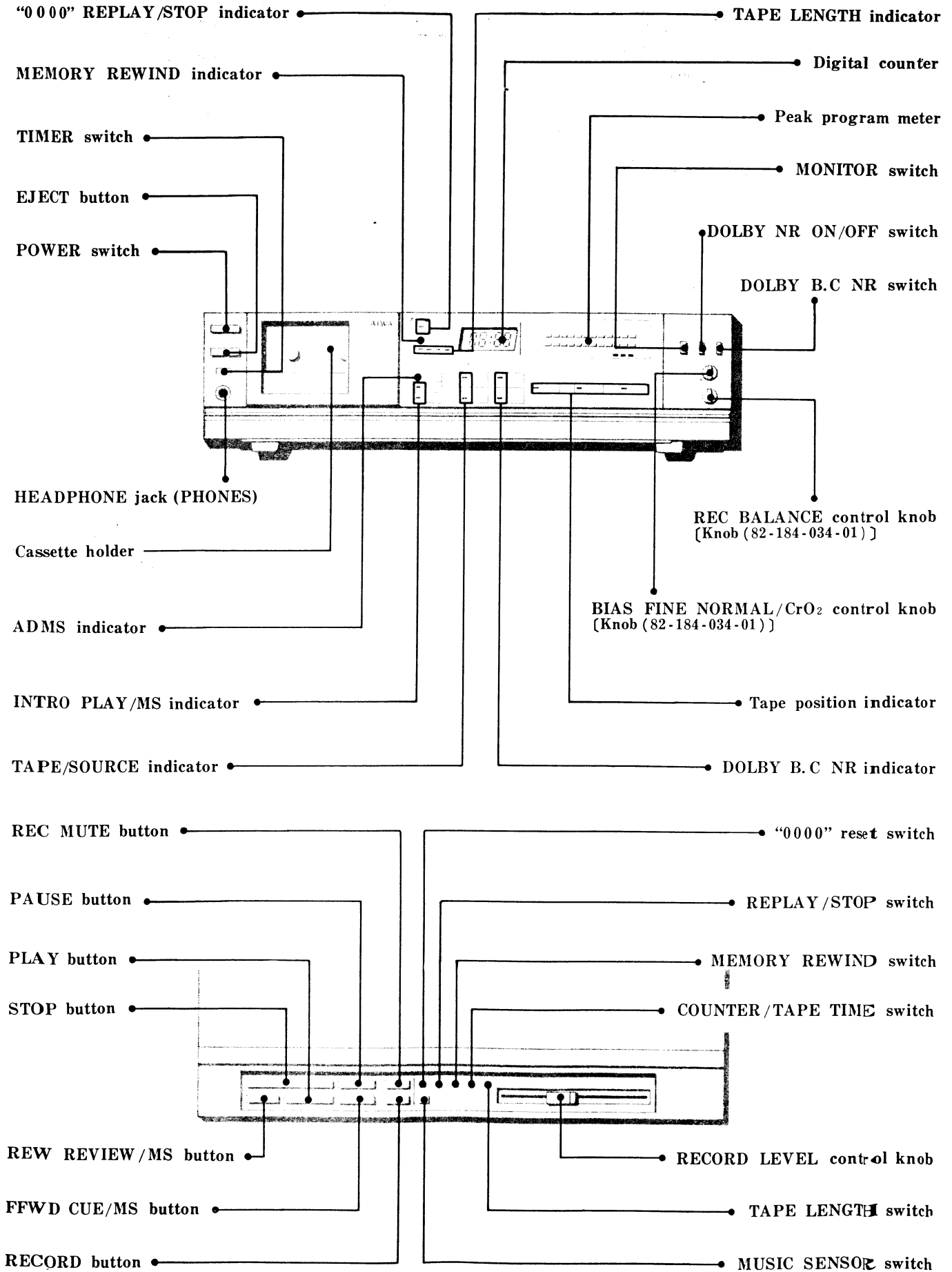

DISASSEMBLING INSTRUCTIONS

1. Removing Cassette Lid

- 1) Open the cassette lid, pull it up in the direction of the arrow. (See Figure-1)

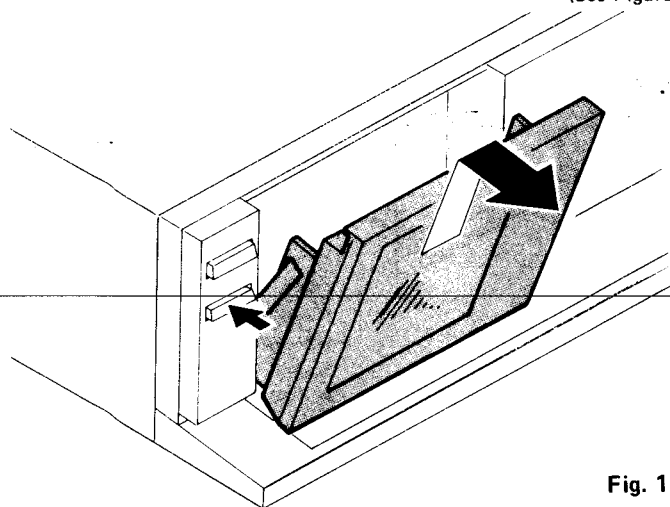

Fig. 1

2. Removing Front Panel

- 1) Remove the 6 screws. (See Figure-2)

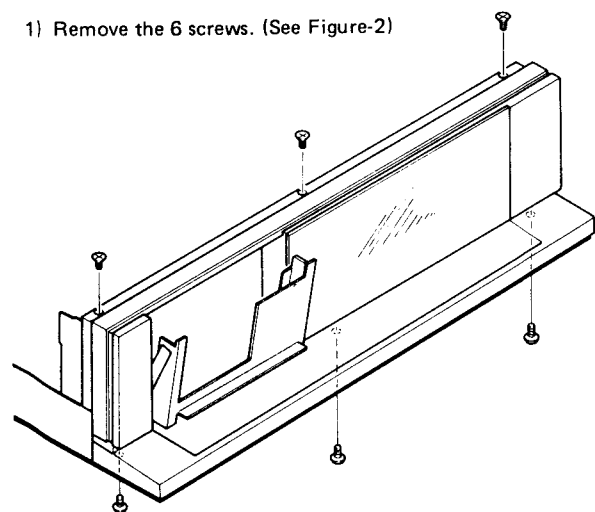

Fig. 2

- 2) Disconnect the 4 connectors (A to D) and draw out the front panel in the direction of the arrow. (See Figure-3)

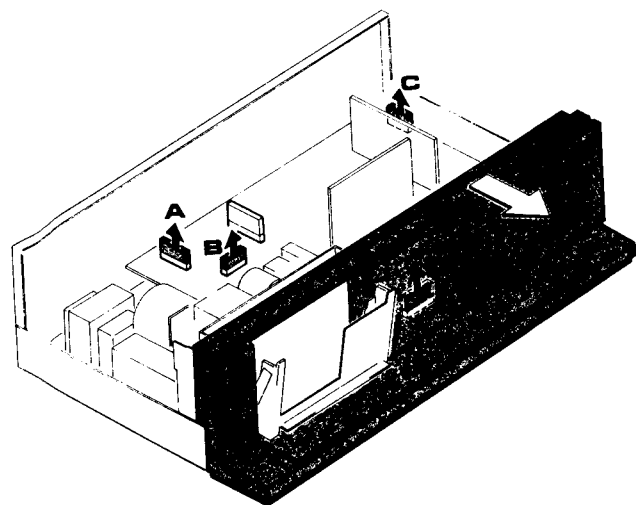

Fig. 3

3. Removing Mechanism

- 1) Remove the 4 screws. (See Figure-4)

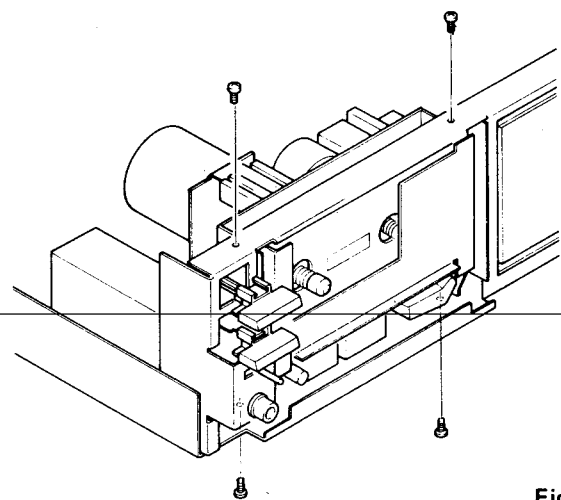

Fig. 4

- 2) Remove the power button and screw to take out the circuit board. (See Figure-5)

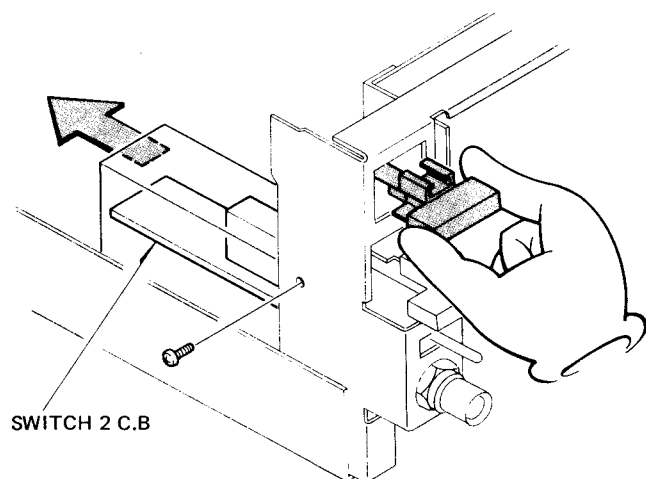

Fig. 5

- 3) Draw out the mechanism backwards while holding the Eject button by fingers. In this case, make confirm that the cassette holder is in a lock condition.
- 4) Disconnect the 5 connectors (E to I). (See Figure-6)

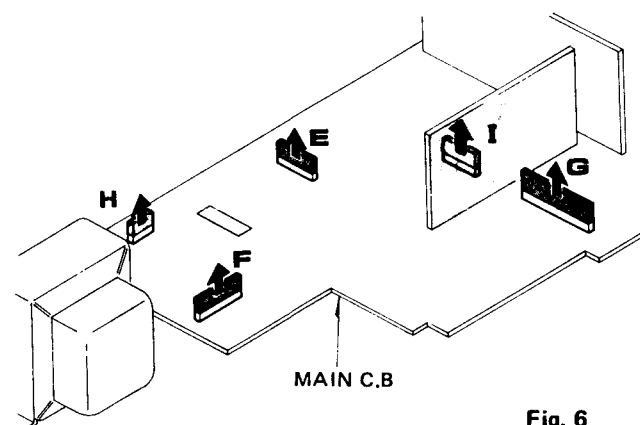

Fig. 6

4. Removing Reel Motor

- 1) Remove the 2 screws to dismount the cassette holder. (See Figure-7)
- 2) Remove the 2 screws pushing the lever for brace release in the direction of the arrow. (See Figure-8)

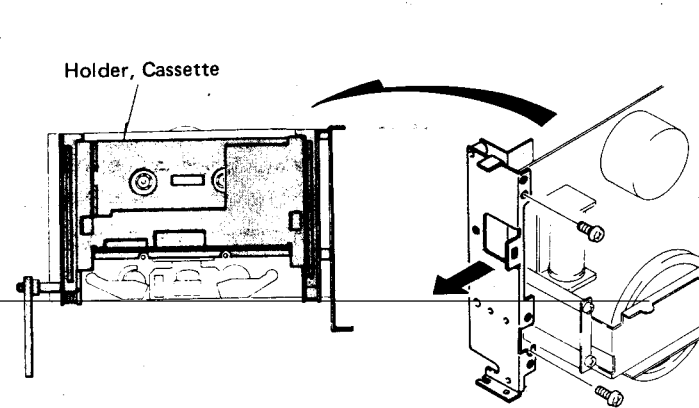

Fig. 7

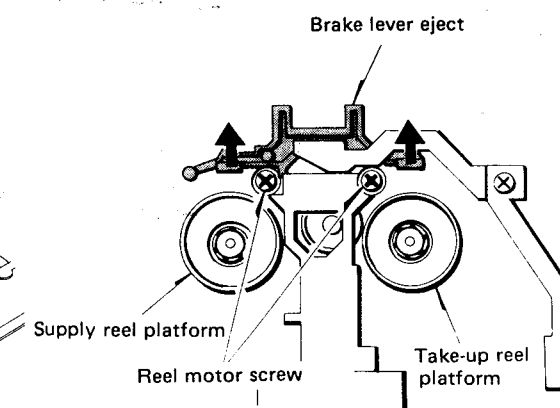

Fig. 8

REPCACEMENT OF ERASE HEAD

- When replacing the EH, fix the new EH temporarily as illustrated and perform the EH adjustment. After that, seal the nut. (Refer to the Wiring-1, No. 9, as to the EH adjustment.)

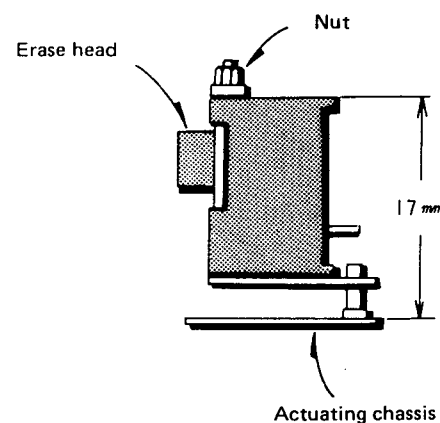

Fig. 9

Follow the instructions carefully, which will allow the user to optimise the products' performance and give many years of service.

1. No scratch and melting shall be made to covered lead-wires of an a.c. primary circuit including mains leads.
2. No illegibility shall be given to the specification plate, the caution labels, the fuse labels and others.
3. When, on pattern sides of circuit boards, additional repair-parts have been made up, the parts shall be firmly glued to circuit boards or other components, unless the parts can be attached firmly.
4. The following matters shall be maintained as they are, when repairing.
 - 1) Soldering of lead-wire ends
 - * Care should be taken of the space distance in an a.c. primary circuit as well as soldering.
 - 2) Wiring and holding of lead-wires with wire-clips and binders
 - 3) Materials of lead-wires
 - * e.g.; For UL models, lead-wires to be used shall be approved or accepted by the UL.
 - 4) Location of all kinds of insulators
5. After repaired, the insulation resistance or leakage current shall be measured with $500 \pm 5V$ D.C and shall be not less than $1M\Omega$.

6. General instructions for mechanism repair

- 1) The heads, capstan and pinch roller shall be cleaned of good quality alcohol after repaired, because dirty heads shall cause distorted sounds while dirty capstan and pinch roller shall occur wow/flutter and take-up fault.
- 2) Lubricants been stained the surfaces of transmitting portion of the belts, idlers, capstan and pinch roller shall be removed, because slippery and faulty tape travel shall be caused.
- 3) When oiling, only one or two drops shall be applied so as not to run over and be dispersed. Note should be taken of the metal fitting for the capstan and rotating portions of the idlers and pinch roller, especially.
- 4) E-rings and poly slider washers shall be replaced with new ones, if once those have been removed. — No re-utilization due to unreliability.
- 5) Regular spare-parts shall always be used for repair, because using irregular parts and tampering with the products shall cause deterioration, malfunction and damage.

Measuring points:

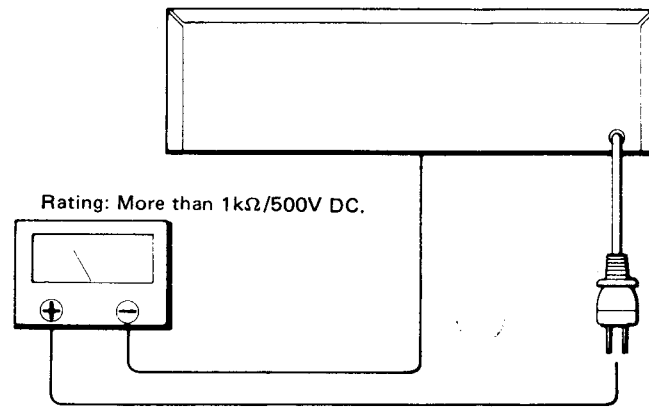

EXPLODED VIEW-1

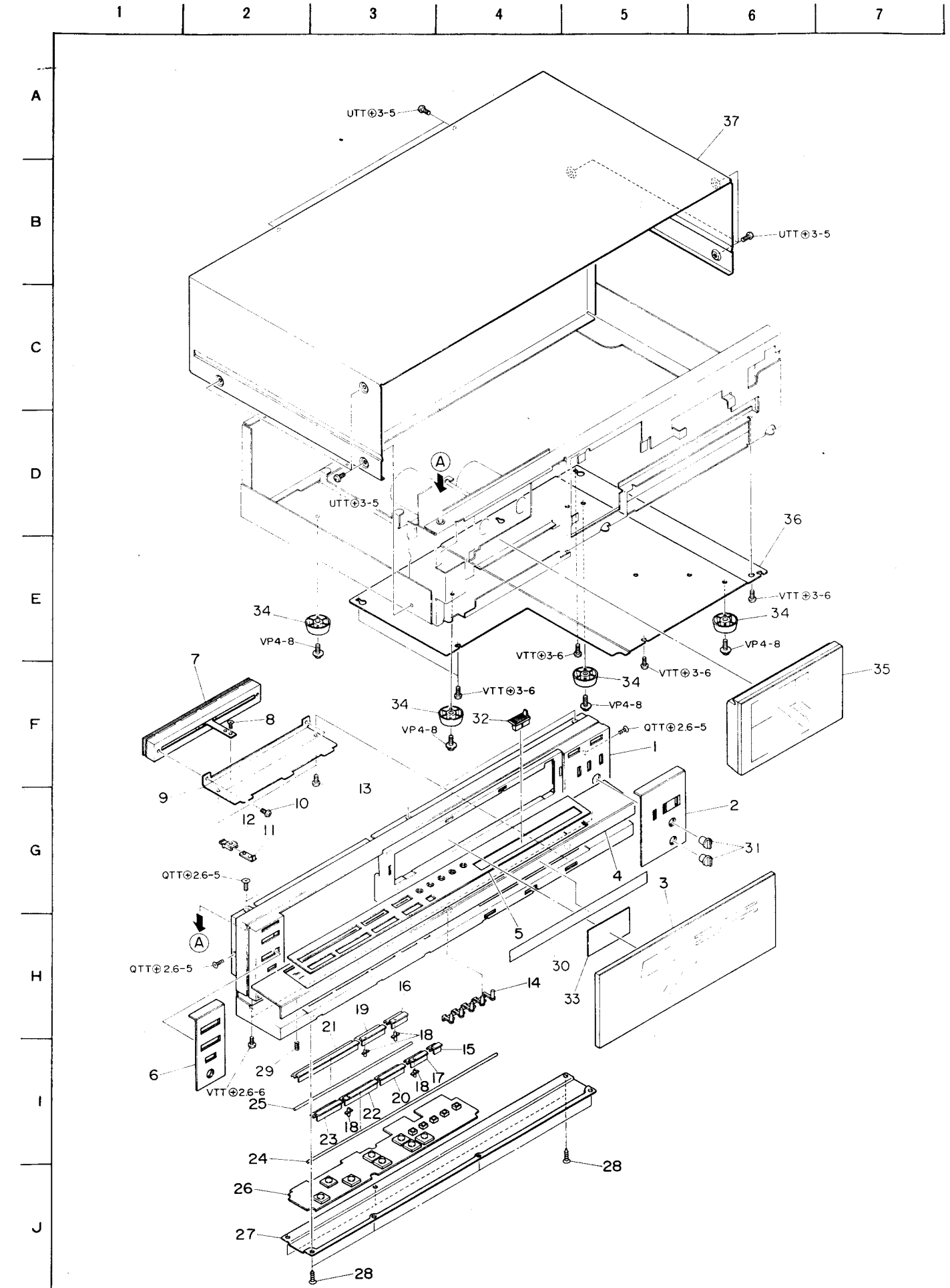

PARTS LIST

MECHANICAL PARTS

■ * mark in this part list shows exclusive part

Ref. No.	Part No.	Parts No. Changed to	Description	Common Model	Q'ty
1~29	82-190-020-01		Front cabinet ass'y	*	1
1-1	82-191-007-11		Cabinet, Front		1
1-2	82-190-014-01		Panel, Front	*	1
1-3	82-190-004-01		Window, Meter	*	1
1-4	82-190-016-11		Panel, Control	*	1
1-5	82-190-001-11		Panel, Control	*	1
1-6	82-188-003-01		Panel L, Front		1
1-7	82-190-670-11		Volume SL ass'y	*	1
1-8	87-231-033-21		Q+2-4		1
1-9	82-191-006-11		Holder, REC volume		1
1-10	87-261-092-21		V+3-4		2
1-11	82-191-201-01		Slide lever		1
1-12	82-190-203-01		Slider, Volume	*	1
1-13	87-321-074-21		QT ₁ +2.6-8		2
1-14	82-188-034-11		Touch-key, Counter		1
1-15	82-188-045-11		Touch-key, MS		1
1-16	82-188-020-01		Touch-key, REC MUTE		1
1-17	82-188-019-01		Touch-key, REC		1
1-18	82-188-037-01		Guide, Light		4
1-19	82-188-022-01		Touch-key, PAUSE		1
1-20	82-188-017-01		Touch-key, FF		1
1-21	82-188-021-01		Touch-key, STOP		1
1-22	82-188-016-01		Touch-key, PLAY		1
1-23	82-188-018-01		Touch-key, REW		1
1-24	82-188-223-01		Shaft A, Touch-key		1
1-25	82-188-224-01		Shaft B, Touch-key		1
1-26	- - - -		Control key A ass'y		1
1-27	82-188-033-01		Cabinet A, Bottom		1
1-28	87-326-073-01		QT ₁ +2.6-6		7
1-29	82-190-215-01		C-spring, Earth	*	1
1-30	82-190-021-11		Sheet, BIAS instruction	*	1
1-31	82-184-034-01		Knob		2
1-32	82-191-003-01		Knob, REC volume		1
1-33	82-190-205-11		Sheet, Poly-Collar	*	1
1-34	87-085-161-01		Foot		4
1-35	82-190-017-01		Cassette window ass'y	*	1
1-36	82-168-018-31		Cabinet, Bottom		1
1-37	82-188-035-01		Cabinet, Steel		1

EXPLODED VIEW-2

1 2 3 4 5 6 7

A
B
C
D
E
F
G
H
I
J

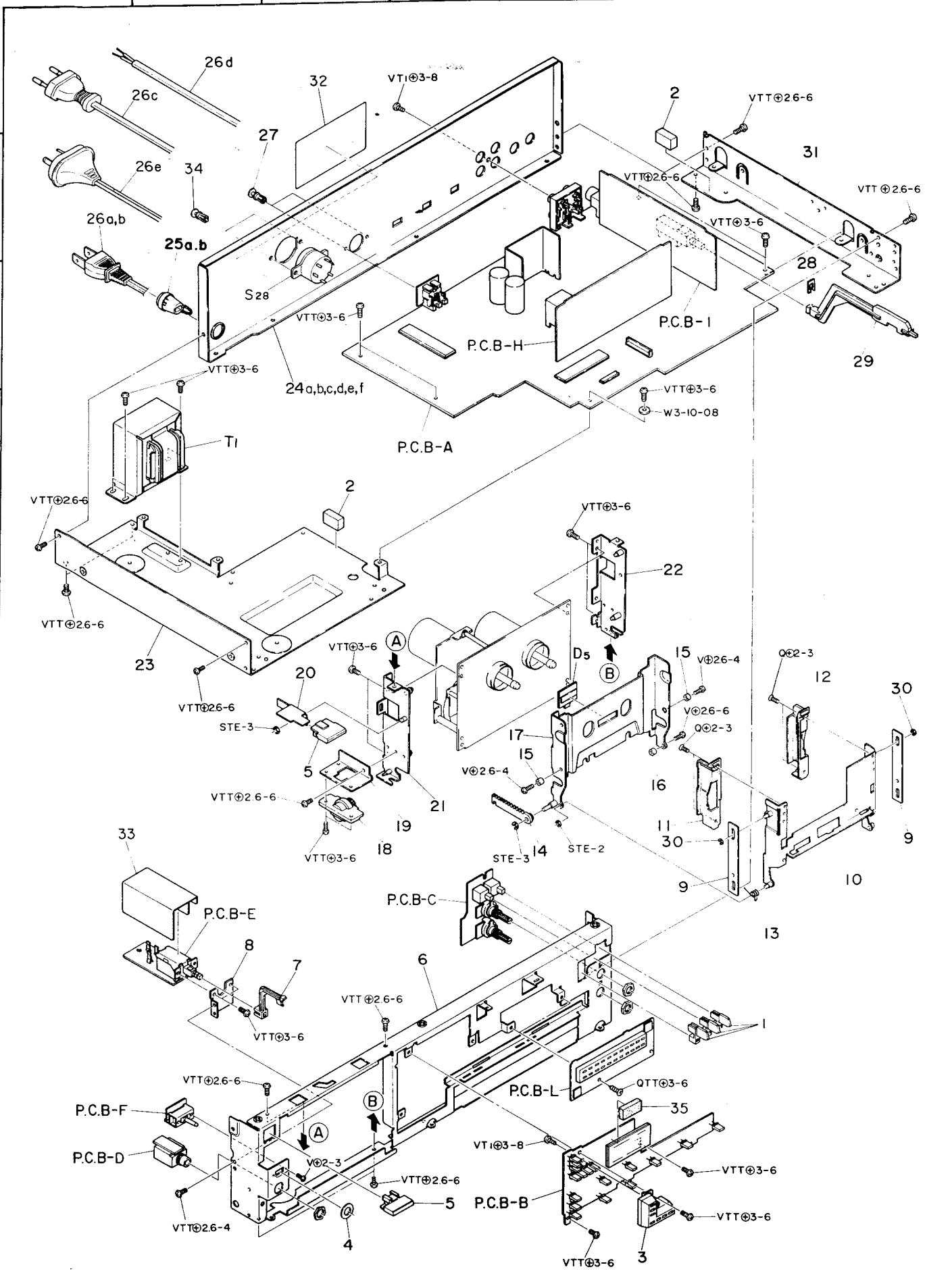

Ref. No.	Part No.	Parts No. changed to	Description	Common Model	Q'ty
2-1	82-191-001-01		Knob, TAPE/SOURCE		3
2-2	82-190-213-01		Rubber cushion	*	2
2-3	82-190-202-01		Guide, LED	*	1
2-4	82-422-073-11		Himeron cloth, Blind		1
2-5	82-188-012-01		Push-button, POWER		2
2-6	82-190-201-01		Front chassis	*	1
2-7	82-757-210-01		Rod	ST-R10	1
2-8	82-162-215-01		Holder, POWER	AD-R500	1
2-9	82-188-210-21		Lever C, Box		2
2-10	82-188-205-21		Cassette box ass'y		1
2-11	82-188-219-01		Holder L, Cassette		1
2-12	82-188-220-01		Holder R, Cassette		1
2-13	82-188-233-11		T-spring, OPEN		1
2-14	82-541-240-11		Lever, Oil-damp	TPR-950	1
2-15	82-188-229-01		Collar, Cassette box lever L		2
2-16	82-188-232-01		Collar, Cassette box lever R		1
2-17	82-188-039-11		Cassette plate ass'y		1
2-18	82-179-228-01		Oil-damper		1
2-19	82-188-211-01		Holder, Oil-damp		1
2-20	82-188-212-11		Plate, EJECT slide		1
2-21	82-188-213-41		Mechanism holder L ass'y		1
2-22	82-188-214-21		Mechanism holder R ass'y		1
2-23	82-188-204-01		Chassis L, Amp.		1
2-24a	82-190-008-01		Panel, Rear (H, HU models only)	*	1
b	82-190-009-01		Panel, Rear (U, C models only)	*	1
c	82-190-010-01		Panel, Rear (E model only)	*	1
d	82-190-011-01		Panel, Rear (K model only)	*	1
e	82-190-012-01		Panel, Rear (G model only)	*	1
f	82-190-013-01		Panel, Rear (Z model only)	*	1
2-25a	87-085-184-01		Cord bushing (H, HU, U, C models only)		1
b	87-085-185-01		Cord bushing (E, K, G, Z models only)		1
2-26a	87-034-826-01		AC power cord (H, HU models only)		1
b	87-034-951-01		AC power cord (U, C models only)		1
c	87-034-877-01		AC power cord (E, Z models only)		1
d	87-034-975-01		AC power cord (K model only)		1
e	87-034-892-01		AC power cord (G model only)		1
2-27	87-084-078-01		Nylon rivet 3-4.5		2
2-28	82-385-383-11		Stopper, Rod		1
2-29	82-309-208-21		Rod, Selector		1
2-30	82-190-206-01		STE-2 (Black)	*	2
2-31	82-188-209-01		Chassis R, Amp.		1
2-32	82-190-015-01		Name plate, Spec. (U model only)	*	1
2-33	82-190-217-01		Cover, POWER (E, K, G, Z models only)	*	1
2-34	87-084-063-01		Nylon rivet 3-5.5 (H, HU models only)		2
2-35	82-190-216-01		G cushion	*	1

EXPLODED VIEW-3

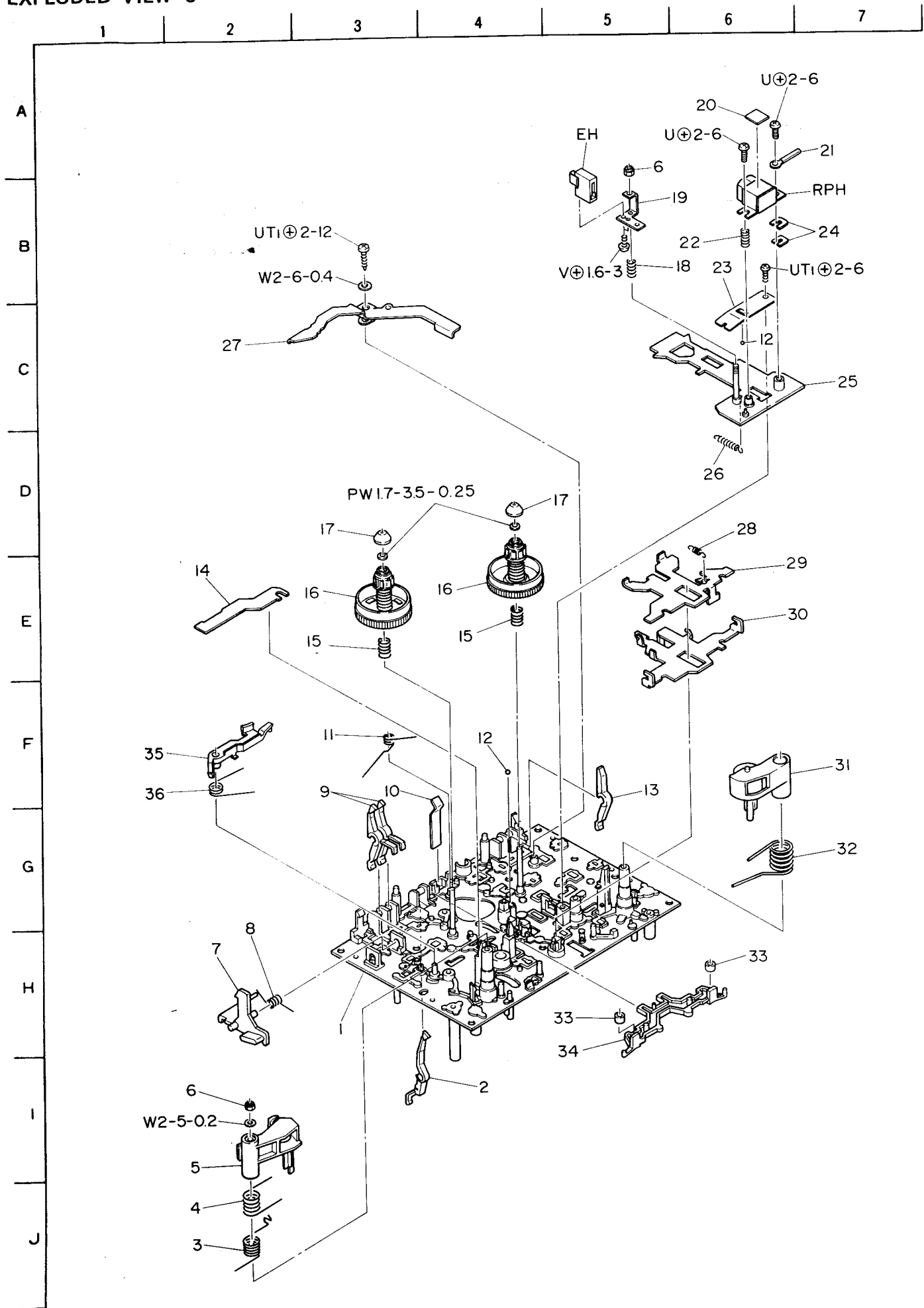

Ref. No.	Part No.	Parts No. Changed to	Description	Common Model	Q'ty
3-1	81-507-201-11		Outsert chassis ass'y		1
3-2	81-505-242-11		Lever, Metal		1
3-3	81-507-228-01		C-spring, Pinch lever S		1
3-4	81-507-217-11		T-spring, Pinch lever S		1
3-5	81-507-207-11		Pinch lever S ass'y		1
3-6	87-081-963-01		Nylon nut M2-3.5		2
3-7	81-505-239-01		Lever, Eject		1
3-8	81-505-273-01		T-spring, Lid lock		1
3-9	81-505-241-21		REC blocking lever		2
3-10	81-505-260-01		P-spring, Pressure cassette		1
3-11	81-505-268-01		T-spring, Slide brake		1
3-12	87-073-005-01		Steel ball 2φ		2
3-13	81-505-240-21		Lever, Cassette sensor		1
3-14	81-505-238-01		Blocking plate, EJECT		1
3-15	81-507-219-01		C-spring, Supply reel platform		2
3-16	81-505-226-11		Take-up reel platform ass'y		2
3-17	82-303-298-01		Cap, Take-up reel platform		2
3-18	82-565-360-01		C-spring, EH		1
3-19	81-507-215-01		Holder, EH		1
3-20	87-057-620-01		Label, Head		1
3-21	87-038-056-01		Wire binder		1
3-22	82-307-212-01		C-spring, EH		1
3-23	81-507-224-01		P-spring, Actuating chassis		1
3-24	81-507-227-01		Spacer		2
3-25	81-507-214-21		Actuating chassis ass'y		1
3-26	81-505-265-11		E-spring, Actuating chassis		1
3-27	81-505-307-01		Lever, Brake eject		1
3-28	81-505-266-01		E-spring, PAUSE plate		1
3-29	81-505-207-01		Plate, PAUSE		1
3-30	81-507-220-01		Plate, Pinch lever		1
3-31	81-505-210-11		Pinch lever F ass'y		1
3-32	81-505-267-01		T-spring, Pinch F		1
3-33	81-507-229-01		G brake		2
3-34	81-505-236-11		Lever, Slide brake		1
3-35	81-507-222-01		Lever, Back tension		1
3-36	81-507-223-01		T-spring, B.T		1

EXPLODED VIEW-4

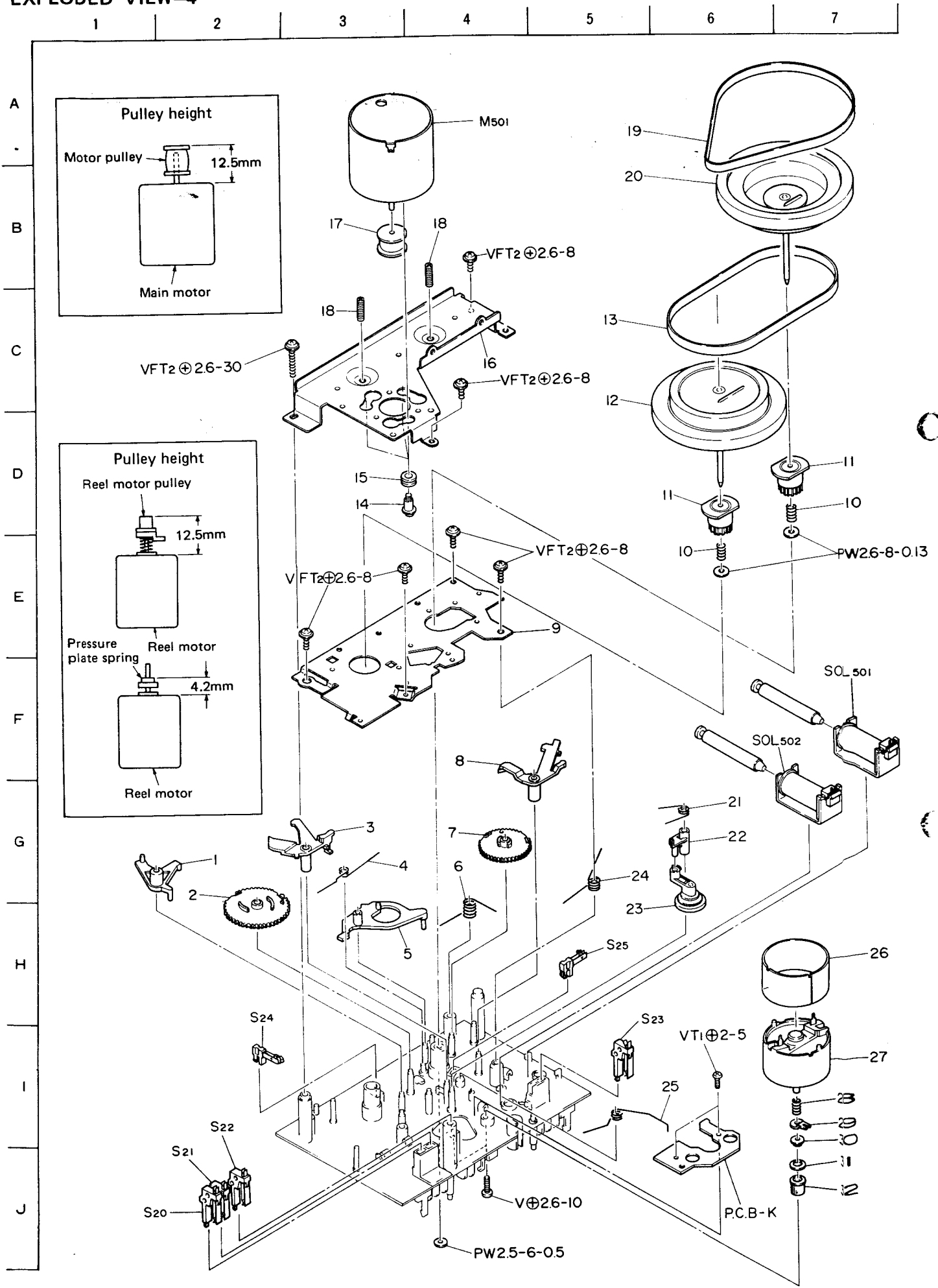

Ref. No.	Part No.	Parts No. Changed to	Description	Common Model	Q'ty
4-1	81-505-230-01		Lever, PLAY		1
4-2	81-505-234-01		Gear, PLAY cam		1
4-3	81-505-231-01		Trigger lever, PLAY		1
4-4	81-505-272-01		T-spring, Cam		1
4-5	81-505-308-01		Lever B, PAUSE		1
4-6	81-505-283-01		T-spring, PAUSE lever		1
4-7	81-505-235-01		Gear, PAUSE cam		1
4-8	81-505-233-01		Trigger lever, PAUSE		1
4-9	81-505-204-01		Chassis B, Mechanism		1
4-10	81-505-261-01		C-spring, Flywheel F		2
4-11	81-505-225-01		Gear, Flywheel		2
4-12	81-507-205-01		Flywheel S ass'y		1
4-13	81-507-225-01		Rubber belt B		1
4-14	87-081-483-01		Motor screw, M2.6		3
4-15	87-087-029-01		Rubber cushion		3
4-16	81-507-221-01		Holder, Motor		1
4-17	81-505-245-01		Motor pulley 2-10-6.8		1
4-18	82-565-373-01		Screw, Thrust		2
4-19	81-507-216-01		Rubber belt A		1
4-20	81-507-203-31		Flywheel T ass'y		1
4-21	81-505-282-01		T-spring, FR idler		1
4-22	81-505-254-01		Lever A, FR idler		1
4-23	81-505-250-21		FR idler ass'y		1
4-24	81-505-271-01		T-spring, Trigger lever		1
4-25	81-505-269-01		T-spring, Pinch plate		1
26~32	09-047-198-01		Reel motor ass'y		1
4-26	81-505-606-01		Shield plate		1
4-27	81-505-604-11		Motor, Reel		1
4-28	81-505-290-01		C-spring, FR idler C		1
4-29	81-505-287-11		Lever C, FR idler		1
4-30	81-505-289-01		Pressure plate spring		1
4-31	81-505-292-11		Felt 4.5-7.2-0.8		1
4-32	81-505-257-01		Pulley, Reel motor		1

SPRING APPLICATION POSITION

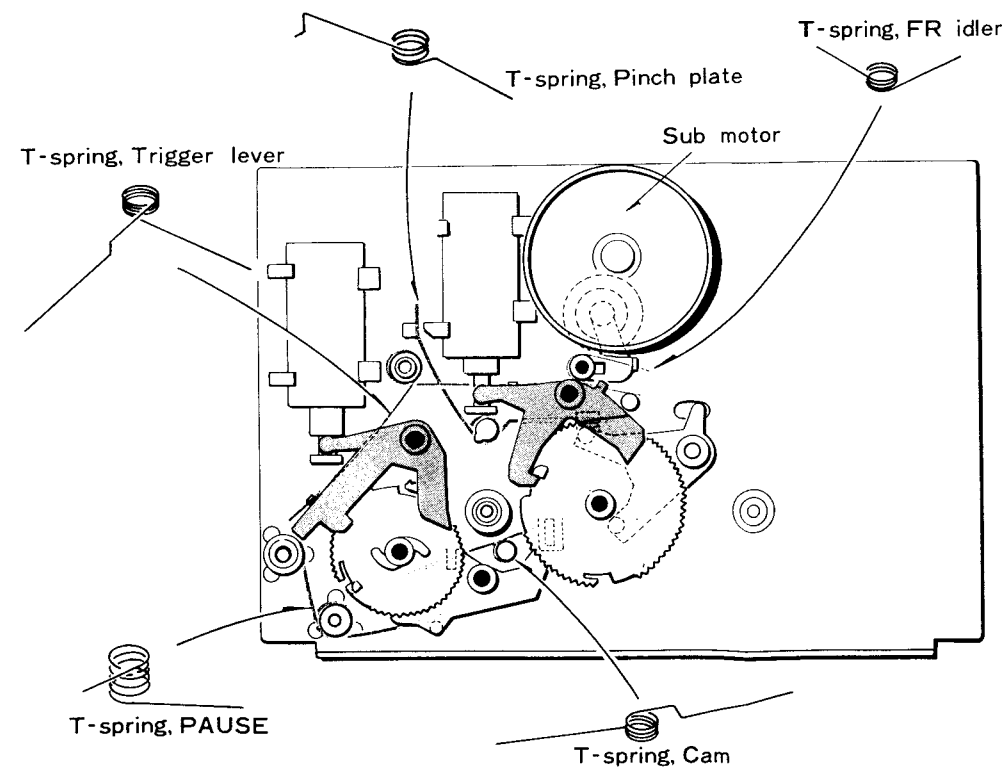
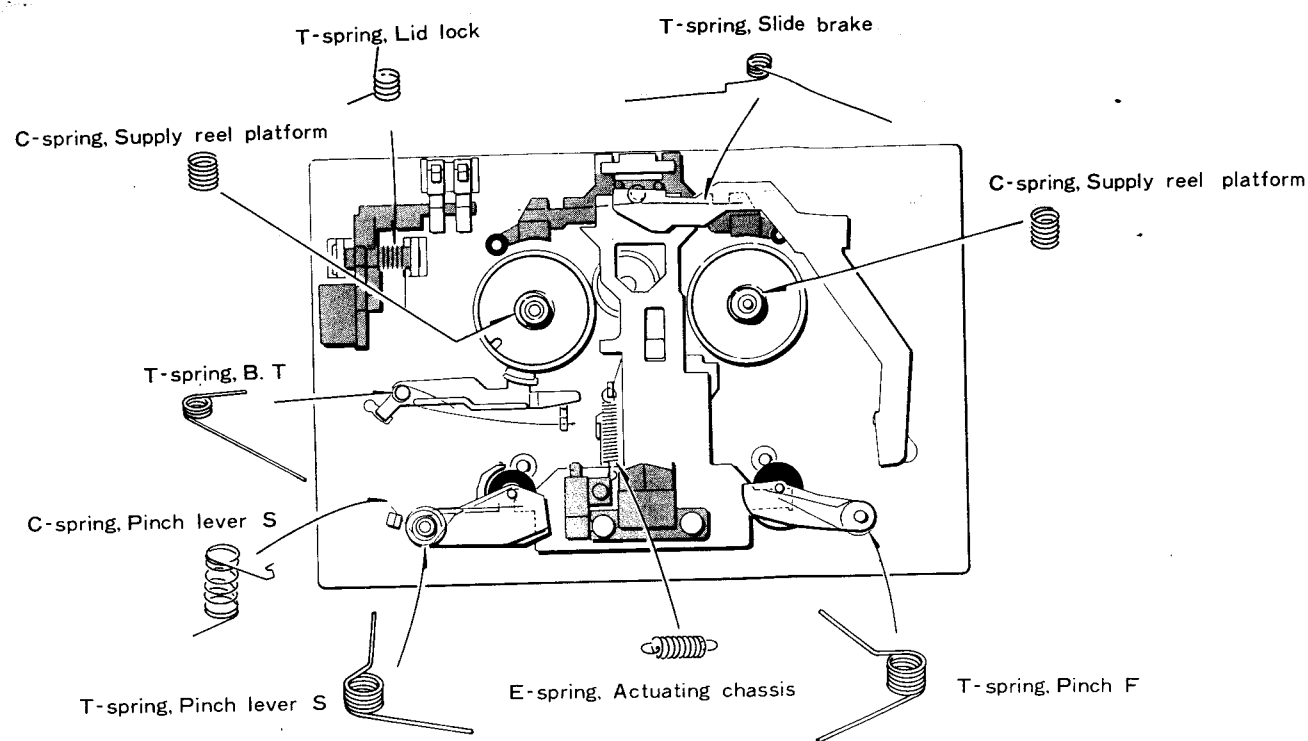

ACCESSORIES/PACKAGE

Ref. No.	Part No.	Part No. Changed to	Description	Common Model	Q'ty
1	82-190-852-01		Printed indiv., Packing	*	1
2	82-188-852-01		Cushion L, Printed indiv.		1
3	82-188-853-01		Cushion R, Printed indiv.		1
4	82-190-853-01		Outer carton (H, HU, C, E, K, G, Z models only)	*	1/3
5	82-190-854-01		Outer carton (U model only)	*	1/3
6	87-051-131-11		Poly-vinyl sack (H, HU, U, C, Z models only)		1
7	87-051-135-11		Poly-vinyl sack (E, K, G models only)		1
8	87-056-627-01		Poly-vinyl sack		1
9	82-190-855-01		Pad, Auxiliary	*	1
10	82-190-904-01		Instructions booklet	*	1
11	87-051-171-11		Poly-vinyl sack		1
12	87-056-008-11		Label, AC power cord (K model only)		1
13	87-056-009-51		Distributors list (H, C, E, K, G, Z models only)		1
14	87-056-045-01		Guarantee card (HU, U models only)		1
15	87-056-057-01		Service station list (HU, U models only)		1
16	87-056-059-01		Guarantee card (G model only)		1
17	87-056-013-01		Guarantee card (C model only)		1
18	87-056-050-01		Safety instruction (U model only)		1
19	87-032-845-01		Siemens plug (H, HU models only)		1
20	87-034-978-01		Connection cord CW-254 BSK		2

AIWA Co., Ltd. Tokyo Japan

ELECTRICAL MAIN PARTS LIST

Symbol No.	Part No.	Description
< MAIN CIRCUIT BOARD SECTION >		
PCB-A	*	Main circuit board
IC1	87-027-919-01	IC, M5230L
IC101, 102, 103, 104, 105	87-027-895-01	IC, M5218L
IC201	87-027-949-01	IC, NJM2043S-A
IC202	87-027-739-01	IC, NJM4556D
IC401, 501	87-027-538-01	IC, μ PD 4069
④IC502	82-191-644-01	IC, HD38755A62
④IC503	82-191-645-01	IC, μ PD546C-357
IC504	87-027-510-01	IC, μ PD4001
Q1	89-108-854-51	Transistor, 2SA885R, S
Q4	89-108-854-51	Transistor, 2SA885R, S (H, HU models only)
Q4	89-210-154-01	Transistor, 2SB1015Y, GR (U, C, E, K, Z, G, models only)
Q3	89-412-653-41	Transistor, 2SD1265 (OP)
Q5, 51, 105, 106, 205, 206, 207, 208, 307, 308, 524, 525, 526, 528, 529	89-320-011-01	Transistor, 2SC2001 (K)
Q6	89-406-555-01	Transistor, 2SD655E
Q52, 54	89-110-155-01	Transistor, 2SA1015 (GR)
503, 504, 505, 516, 518, 519, 522		
Q53, 103, 104, 107, 108~115, 116, 201, 202, 203, 204, 301, 303, 304, 305, 309, 310, 311, 501, 502, 506~515, 517, 527	89-318-155-01	Transistor, 2SC1815 (GR)
Q101, 102	89-309-455-61	Transistor, 2SC945L (PQ)
Q117, 118	89-321-204-01	Transistor, 2SC2120 (Y)
Q303, 306, 512, 520, 521	89-109-521-01	Transistor, 2SA952K
D1	87-027-815-01	Diode, 1B4B1
D2, 3, 302, 513	87-027-475-01	Zener diode, HZ-6B1
D4, 502	87-027-686-01	Zener diode, HZ-12A1
D51, 52, 53, 54, 55, 101, 102, 103, 104, 303, 304, 305, 307, 308, 402, 403, 405, 501, 503~512, 520	87-027-097-01	Diode, IS1555
D514	87-027-584-01	Zener diode, HZ9LC1
L101, 102	87-030-061-01	Low-pass filter, 85K
L103, 104	87-005-093-01	Micro inductor coil, 4,7mH
L105, 106	87-005-148-01	Coil, 23mH
L107, 108	82-190-627-01	Coil, F10
L201, 202	82-190-629-01	Low-pass filter, 85K-2
L302	87-003-051-01	Choke coil, 470 μ H
L303	82-190-666-01	OSC coil, EH
X501	87-008-236-01	Ceramic resonator CSB 400P
RY301	87-031-751-01	SW solenoid
J1, 2	82-191-648-01	Jack, 6,3 ϕ w/switch (MIC)
J3, 4, 5, 6	87-049-055-01	4P pin jack (LINE IN, LINE OUT)
J8	87-032-985-01	DIN socket 8p (REMOTE)
S2	82-191-655-01	Push-switch (MONITOR)
S18, 19	87-031-752-01	Slide switch (MPX FILTER PHONES LEVEL)
S27	87-031-752-01	Slide switch (Z model only)
SFR101, 102, 203, 204	87-021-687-01	Semi-fixed resistor, 30k Ω -B
SFR103, 104	87-021-613-01	Semi-fixed resistor, 10k Ω -B
SFR201, 202	87-021-569-01	Semi-fixed resistor, 50k Ω -B
PIN1	82-189-649-01	Pin, 9P

Symbol No.	Port No.	Description
PIN2	82-190-668-01	Pin, 6P
PIN3	87-049-150-01	Pin, 10P
PIN4	87-049-152-01	Pin, 12P
PIN5	87-049-038-01	Pin, 3P
PIN7	87-049-065-01	Pin, 5P
PIN8	87-049-044-01	Pin, 7P
PIN9	87-049-143-01	Pin, 3P
PIN10	87-049-050-01	Pin, 6P
CON11	82-190-648-01	Connector ass'y, 4P
< Resistors >		
R1, 3	87-029-023-01	47 Ω $\frac{1}{4}$ W Fuse resistor
R11	87-029-367-01	15 Ω $\frac{1}{4}$ W Fuse resistor
R189, 190	87-029-102-01	47 Ω $\frac{1}{4}$ W Fuse resistor
R13, 17, 332	87-029-094-01	15 Ω $\frac{1}{4}$ W Fuse resistor
R650	87-029-094-01	15 Ω $\frac{1}{4}$ W Fuse resistor (U, C, E, K, G, Z models only)
R522	87-025-150-01	180 Ω 1W Metal film
< Capacitors >		
C1, 2	87-015-987-01	2200 μ F 16V Electrolytic
C105, 106, 207, 208	87-015-425-01	1 μ F 25V Aluminum solid
C131	87-014-118-01	0.015 μ F PP
C137, 138	87-014-037-01	150pF PP
C139, 140	87-014-033-01	100pF PP
C153, 154	87-014-061-01	1500pF PP
C155, 156	87-014-055-01	820pF PP
C203, 204	87-014-119-01	0.027 μ F PP
C306	87-015-379-01	1 μ F 50V Electrolytic BP
C502, 503	87-014-041-01	220pF PP
< LED CIRCUIT BOARD SECTION >		
PCB-B	*	LED circuit board
Q601 ~ 604	89-318-155-01	Transistor, 2SC1815 (GR)
D601, 602, 603, 607, 612, 617	87-027-542-01	LED, LN217RP (STOP, MEMO REWIND, REPLAY, C, MT, INTRO)
D605, 613, 615	87-027-671-01	LED, LN417YP (SOURCE, CrO ₂ , ADMS)
D604, 606, 608	87-027-543-01	LED, LN317GP (TAPE B, 46L, 120, 90, 60, 46, NORMAL, MS)
609, 610, 611, 614, 616		
FL601	82-190-625-01	Electronics counter 4
< SWITCH-1 CIRCUIT BOARD SECTION >		
PCB-C	*	Switch-1 circuit board
D306	87-027-097-01	Diode, IS1555
VR1	82-190-628-01	Volume, 1k Ω -B (BIAS)
VR2	82-191-647-01	Volume, 250k Ω -W (BALANCE)
S3, 4	87-031-692-01	Push-switch (DOLBY ON/OFF, B/C)
< JACK CIRCUIT BOARD SECTION >		
PCB-D	*	Jack circuit board
J7	82-191-649-01	Jack, 6,3 ϕ (HEADPHONES)
< SWITCH-2 CIRCUIT BOARD SECTION >		
PCB-E	*	Switch-2 circuit board
F1	87-035-217-01	Fuse, "T" 315mA (H, HU models only)
F1	87-035-293-01	Fuse, 400mA (U, C models only)
F1	87-035-132-01	Fuse, 160mA (T) (E, K, Z, G models only)
F1	87-033-147-01	Fuse clamp
S26	82-304-743-01	1P terminal
S26	87-031-735-01	Push-switch (POWER)
C1	87-019-112-01	< Capacitor > 0,01 μ F Spark killer

Symbol No.	Port No.	Description
< SWITCH-3 CIRCUIT BOARD SECTION >		
PCB-F	*	Switch-3 circuit board section
S1	82-191-657-01	Slide switch (TIMER)
< VOLUME CIRCUIT BOARD SECTION >		
PCB-G	82-190-642-01	Volume circuit board
VR3	82-191-641-01	Slide volume, 100k Ω -A (RECORD LEVEL)
CON10	82-190-646-01	Connector ass'y, 6P
< DOLBY-NR1, 2 CIRCUIT BOARD SECTION >		
IC1, 2	82-191-630-01	Dolby-unit (W/PCB-H, I)
L1, 2	87-027-918-01	IC, HA12038-01
PIN	87-005-155-01	Coil, 36mH
PIN	87-049-117-01	Pin, 7P
PIN	87-049-119-01	Pin, 9P
< Resistors >		
R9, 10	87-025-271-01	5,1k Ω $\frac{1}{4}$ W Metal film
R11, 12	87-025-295-01	15k Ω $\frac{1}{4}$ W Metal film
R35, 36	87-025-296-01	56k Ω $\frac{1}{4}$ W Metal film
< Capacitors >		
C15, 16	87-015-617-01	10 μ F 16V Electrolytic LL
C21, 22, 23, 24, 45, 46	87-015-366-01	0,15 μ F 10V Aluminum solide
< KEY BOARD CIRCUIT BOARD SECTION >		
PCB-J	82-190-641-01	Key board circuit board
D515, 516	87-027-921-01	LED, SR506 (REC, REC MUTE)
D517	87-027-922-01	LED, SR206D (PAUSE)
D518	87-027-923-01	LED, SY406D (PLAY)
S5, 6, 7, 11, 12, 13, 14, 15	87-031-498-01	Tact switch (STOP, PAUSE, REC MUTE, REW, PLAY, FF, REC, MS)
S8, 9, 10, 16, 17	87-031-642-01	Tact switch (RESET, MEMO REWIND, LENGTH, REPLAY/ STOP, TAPE TIME)
CON6	82-190-643-01	Connector ass'y, 8P
CON7	82-190-645-01	Connector ass'y, 5P
CON8	82-190-644-01	Connector ass'y, 7P
< AUTO STOP CIRCUIT BOARD SECTION >		
PCB-K	81-505-605-01	Auto stop circuit board
CP501, 502	87-027-644-01	Photo sensor, NJL-5141 EA
< INDICATOR CIRCUIT BOARD SECTION >		
	82-190-624-01	LED indicator ass'y (W/PCB-L)
< MISCELLANEOUS >		
T1	82-190-631-01	Power transformer (H, HU models only)
T1	82-190-632-01	Power transformer (U, C models only)
T1	82-190-633-01	Power transformer (E, Z models only)
T1	82-190-634-01	Power transformer (K, G models only)
RPH	87-046-194-11	REC/PB head
EH	87-046-192-01	Erase head
M501	87-045-175-01	DC motor, System servo
M502	09-047-198-01	Reel motor
D5	87-027-944-01	LED, SLF301C
SOL501	81-507-603-01	Solenoid 9ME-B (PAUSE)
SOL502	81-505-603-01	Solenoid 9ME-A (PLAY)
S20, 21, 22, 23	81-505-607-01	Leaf switch (REC, CrO ₂ , METAL, CASSETTE)
S24, 25	81-505-601-01	Leaf switch (PLAY, PAUSE)
S28	87-031-586-01	Rotary switch (VOLTAGE SELECTOR) (H, HU models only)
	87-038-060-01	Heatsink
	82-598-637-01	Heat sink

Symbol No.	Port No.	Description
	87-034-826-01	AC power cord (H, HU models only)
	87-034-951-01	AC power cord (U, C models only)
	87-034-877-01	AC power cord (E, Z model only)
	87-034-975-01	AC power cord (K model only)
	87-034-892-01	AC power cord (G model only)
	87-085-184-01	Cord bushing (H, HU, U, C models only)
	87-085-185-01	Cord bushing (E, K, G, Z models only)
CON1	81-505-631-11	Connector ass'y, 9P
CON2	81-597-602-01	Connector ass'y, 6P
CON3	81-505-632-01	Connector ass'y, 10P
CON4	81-507-601-01	Connector ass'y, 12P
CON5	89-051-003-01	Connector ass'y, 3P

⚠ Safety component symbol
 This symbol is given to important parts which serve to maintain the safety of the product, and which are made to conform to special safety specifications. Therefore, when replacing a component with this symbol, make absolutely sure that you use a designated part.

C-MOS IC handling precaution
 The C-MOS IC's construction makes this part susceptible to damage by static electricity and so take sufficient care in regard to following articles.
 1. Need to be put on conductive sheet, to be put in a metallic box and to be wrapped by aluminium foil for transportation and deposit.
 2. To use solder iron less than 40W (less than 260°C) of power consumption for soldering. But do not overheat more than 10 second.
 3. Do not perform a conductivity test with a tester, etc. Refer to the circuit voltages of each part.
 4. The ICs on the electrical parts which are indicated by an C-MOS IC symbol mark (Ⓢ).

Note; Combination Circuit Board
 The parts on the electrical parts list which are indicated by an asterisk (*) are supplied as one single combined circuit board. Therefore, they will not be supplied separately. If this becomes necessary, please order the entire circuit board.

Combination circuit board A 82-190-601-21

PCB-A	82-190-602-21
PCB-B	82-190-603-21
PCB-C	82-190-604-21
PCB-D	82-190-607-21
PCB-E	82-190-605-21
PCB-F	82-190-606-21

• Ceramic capacitor
 87-018-□□□-01

Capacitor	Parts code
150pF	034
220pF	036
1,000pF	044
0,01 μ F	047

A
B
C
D
E
F
G
NO
1)
2)
3)
4)
5)
6)
7)

- NOTES:
 1) B (+) power supply B (-) power supply
 2) Signal path
 Rec path,

SCHEMATIC DIAGRAM-2

1 2 3 4 5 6 7 8 9 10 11 12 13 14 15 16

A
B
C
D
E
F
G
H
I
J

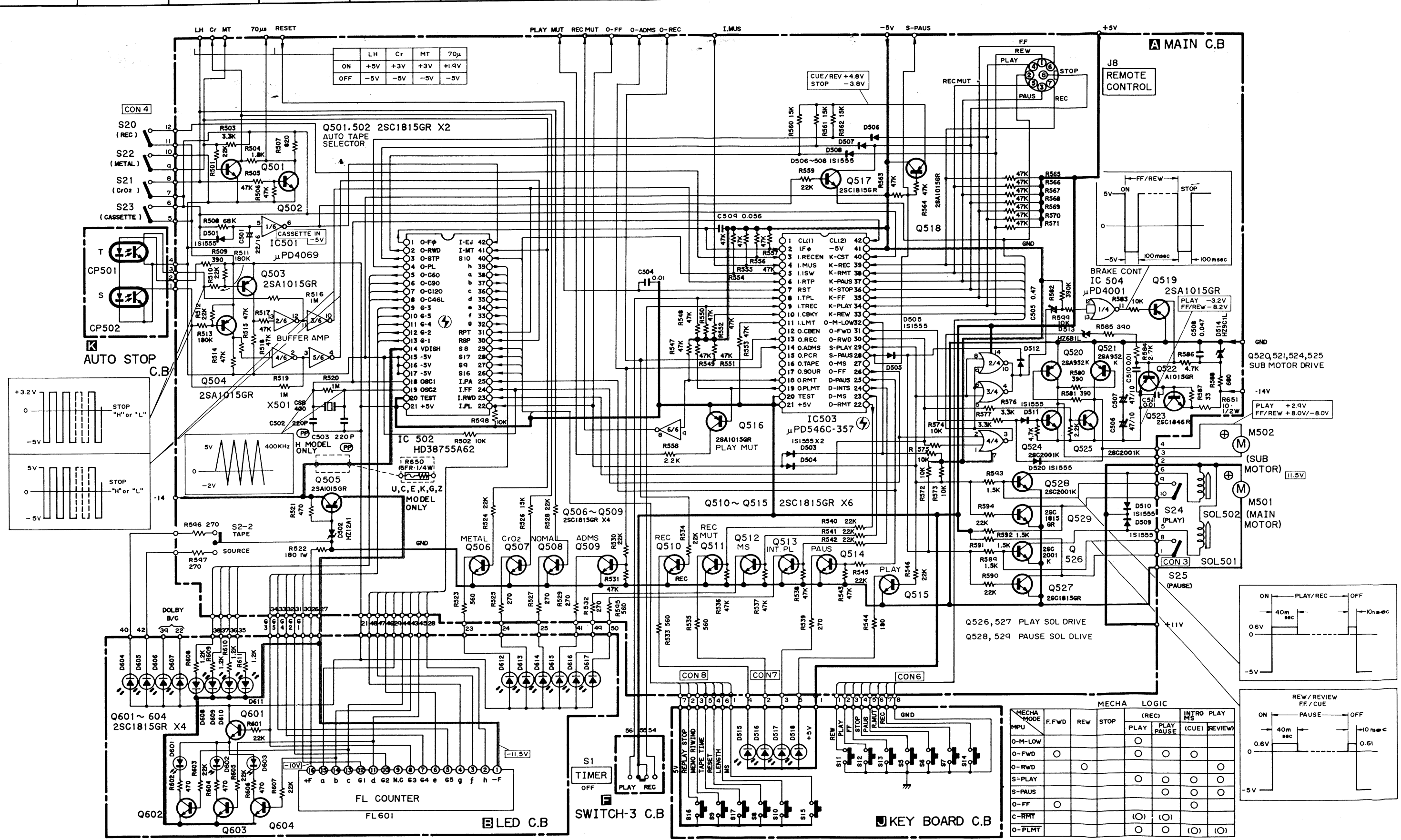

	LH	Cr	MT	70µ
ON	+5V	+3V	+3V	+1.9V
OFF	-5V	-5V	-5V	-5V

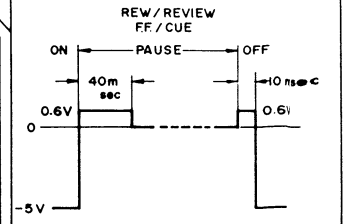
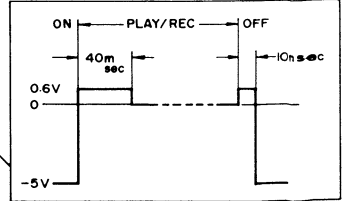
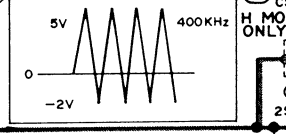
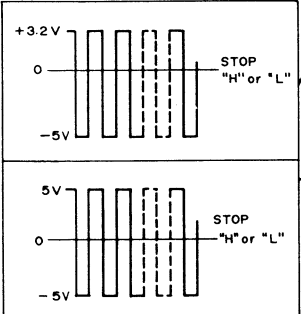
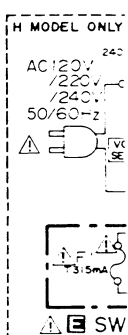
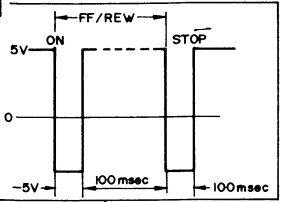
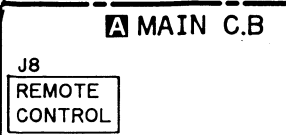

MECHA MODE	MECHA LOGIC				INTRO MS	PLAY (CUE)	REVIEW
	F.FWD	REW	STOP	(REC) PLAY PAUSE			
O-M-LOW							
O-FWD							
O-RWD							
S-PLAY							
S-PAUS							
O-FF							
C-RMT							
O-PLMT							

○: HIGH LEVEL

U, C
E, Z
K, G
AC1
AC2
AC3
U,
E,

7. CrO₂ REC/P.B Frequency Characteristic Adjustment
Settings:
 • Test tape : TTA-119G
 • Input signals : LINE IN 1kHz/10kHz (30mV)
 • Test point : LINE OUT
 • Adjustment locations : SFR103(Lch)
 SFR104(Rch)
Method: Supply a 1kHz, 30mV signal and adjust the recording level so that the LINE output is made 38mV.
 Recording and playback the 1kHz and 10kHz signals and adjust so that the output of 10kHz is 0~+0.5dB based on the 1kHz output.

6. DOLBY-HX Adjustment
Settings:
 • Test point : TP1(Lch)
 TP2(Rch)
 • Adjustment locations : L107(Lch)
 L108(Rch)
Method: Adjust so that the voltage at test point become reduced to maximum value.
 (Reference value : -1~-2V)

5. Bias OSC Frequency Adjustment
Settings:
 • Test point : TP3
 • Adjustment location : L303
Method: Adjust so that the frequency at test point become 85kHz ± 1kHz.

3. Playback Frequency Characteristic Adjustment
Settings:
 • Test tape : TTA-117E
 • DOLBY-NR : OFF
 • Test point : LINE OUT
 • Adjustment locations : SFR201(Lch)
 SFR202(Rch)
Method: Playback the test tape and adjust so that the output of 10kHz is 0 ± 0.5dB based on the 1kHz output.

4. Playback Sensitivity Adjustment
Settings:
 • Test tape : TTA-161
 • DOLBY-NR SW : OFF
 • Test point : LINE OUT
 • Adjustment locations : SFR203(Lch)
 SFR204(Rch)
Method: Playback the test tape and adjust so that the output is set to 540mV.

8. CrO₂ REC/P.B Sensitivity Adjustment
Settings:
 • Test tape : TTA-119G
 • Adjustment locations : SFR101(Lch)
 SFR102(Rch)
 • DOLBY-NR SW : OFF
 • MONITOR SW : SOURCE-TAPE
 • Input signal : 1kHz
Method: Supply a 1kHz signal and adjust the recording level so that the LINE output is 38mV.
 Next, set the MONITOR switch to the TAPE position.
 Record and playback the 1kHz signal and adjust so that the output is 38mV ± 0.5dB.

A MAIN C.B

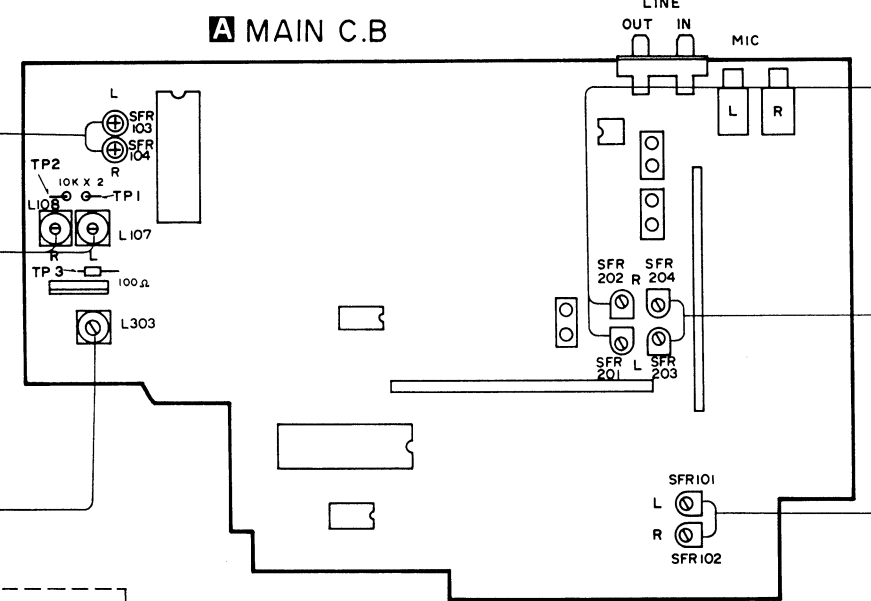

INDICATOR C.B

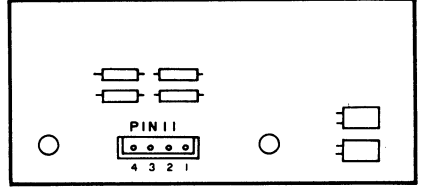

H, HU, MODEL ONLY

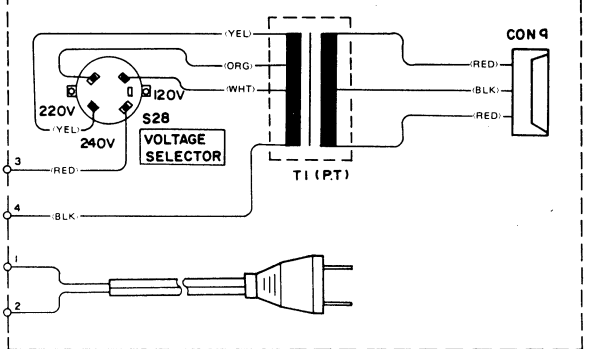

G VOLUME C.B

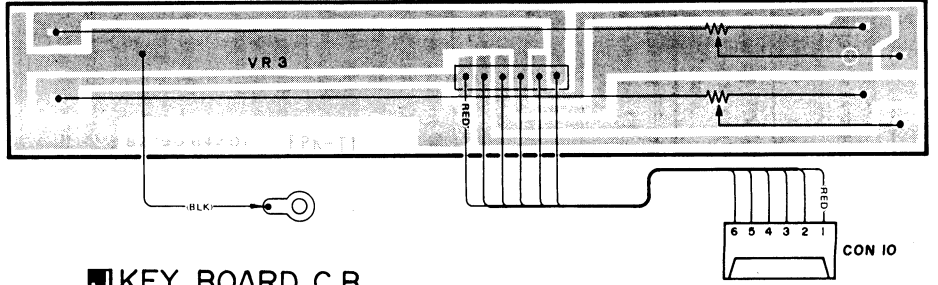

KEY BOARD C.B

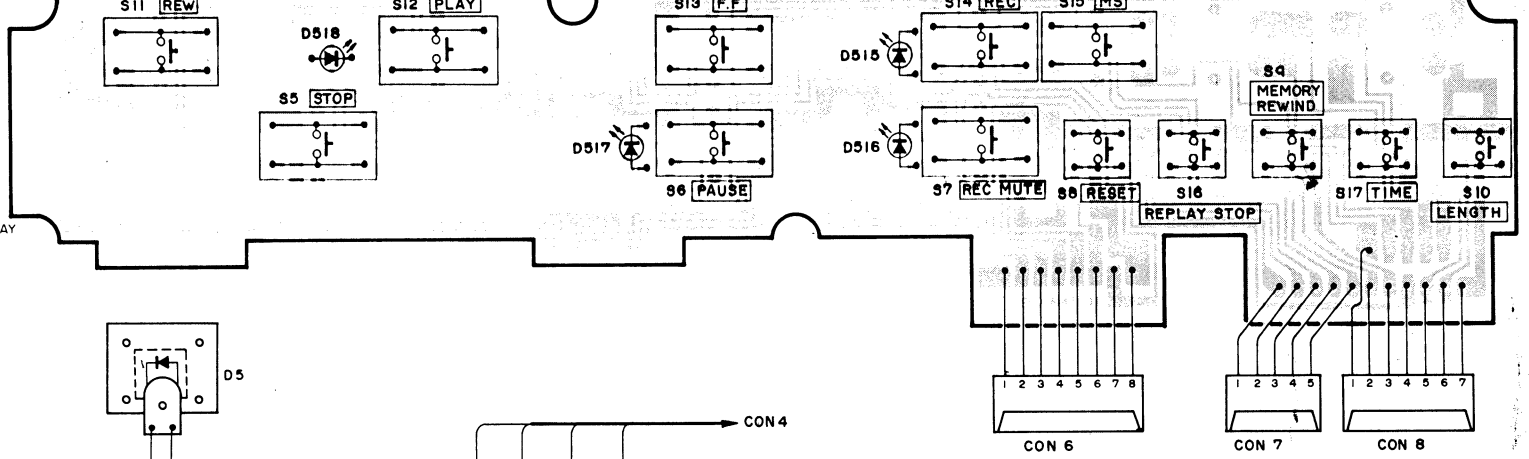

SWITCH-2 C.B

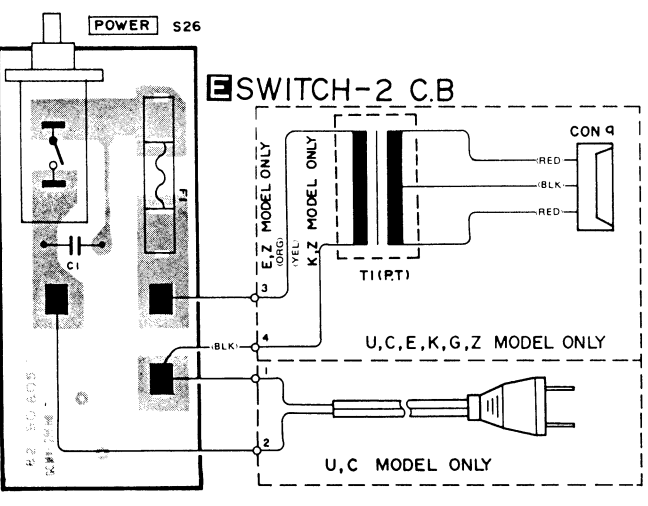

SWITCH-3 C.B

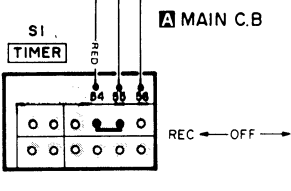

JACK C.B

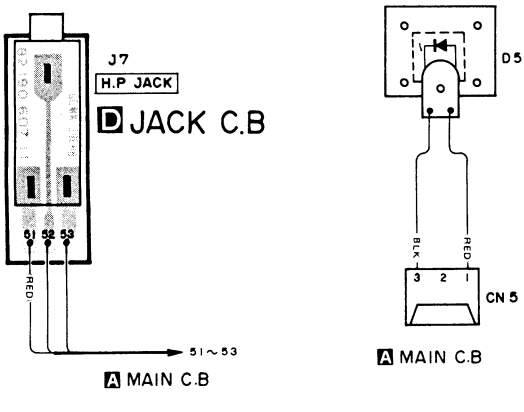

AUTO STOP C.B

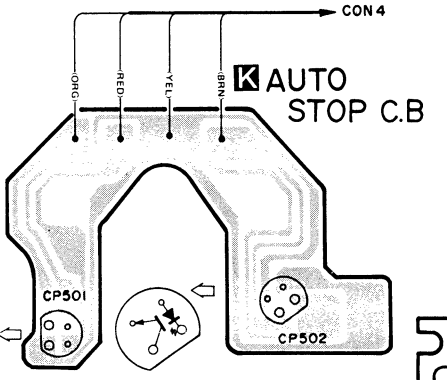

LED C.B

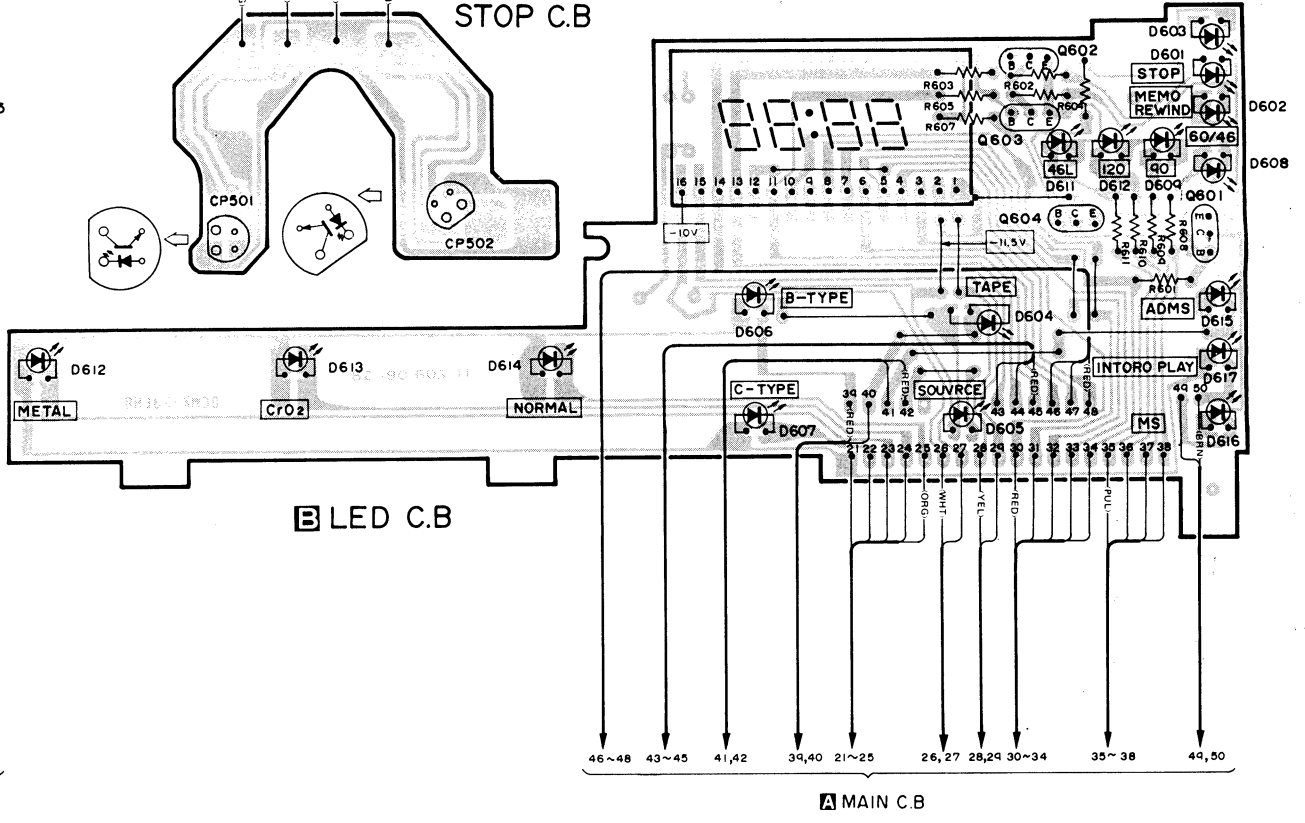

SWITCH-1 C.B

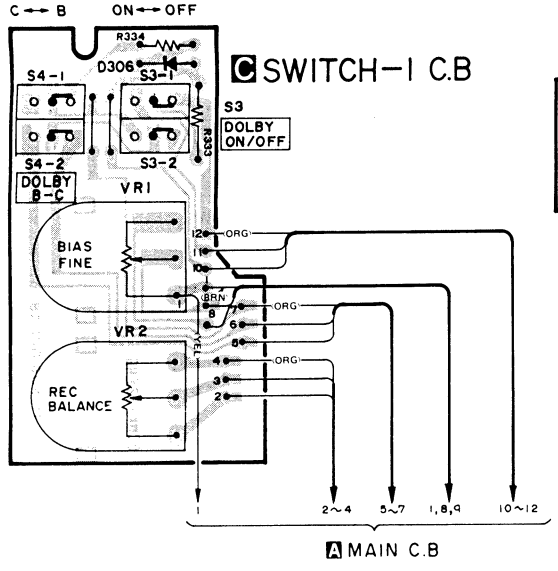

NOTES (1) Earth Pattern (2) The voltage is the reference value measured with a tester (20 K ohms/V DC) when there are no signals. An asterisk (*) indicates that the value was measured with a vacuum-tube voltmeter during recording. The CMOS IC's construction makes this part susceptible to damage by static electricity and so take sufficient care in regard to following articles. 1. Need to be and to be deposit.

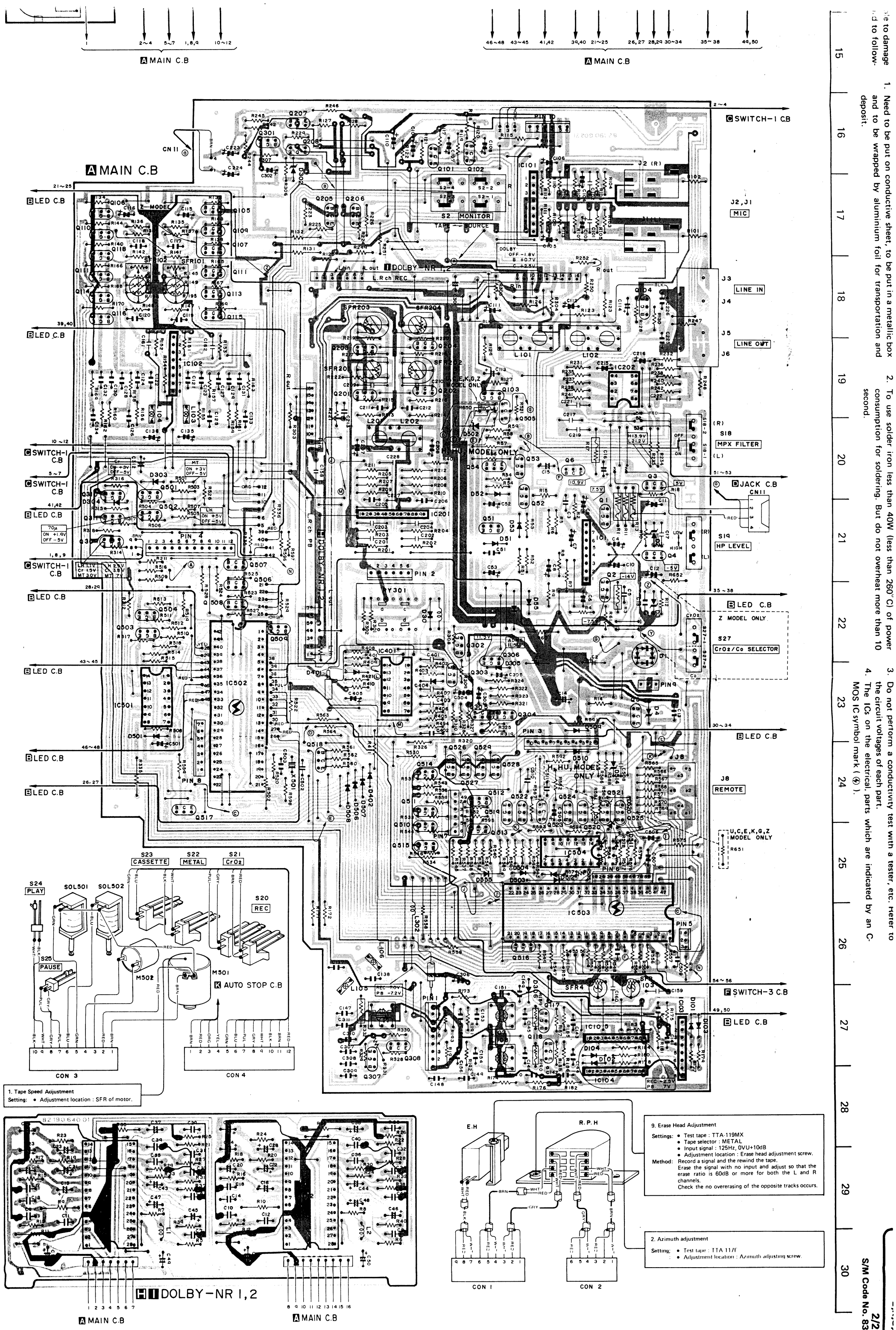

1. Need to be put on conductive sheet, to be put in a metallic box and to be wrapped by aluminum foil for transportation and deposit.
2. To use solder iron less than 40W (less than 260°C) of power consumption for soldering. But do not overheat more than 10 second.
3. Do not perform a conductivity test with a tester, etc. Refer to the circuit voltages of each part.
4. The ICs on the electrical parts which are indicated by an C-MOS IC symbol mark (Ⓢ).

1. Tape Speed Adjustment
 Setting: ● Adjustment location: SFR of motor.

9. Erase Head Adjustment
 Settings: ● Test tape: TTA-119MX
 ● Tape selector: METAL
 ● Input signal: 125Hz, 0VU+10dB
 Adjustment location: Erase head adjustment screw.
 Method: Record a signal and the rewind the tape. Erase the signal with no input and adjust so that the erase ratio is 60dB or more for both the L and R channels. Check the no overdriving of the opposite tracks occurs.

2. Azimuth adjustment
 Setting: ● Test tape: TTA 11/F
 ● Adjustment location: Azimuth adjusting screw.

Circuit description

1. Outline
 This controller is the combination of the deck mechanical controller with the dual capstan CUE and REVIEW and the electronic counter controller which incorporates a remaining tape indicator.

2. Controller and peripheral circuit diagram

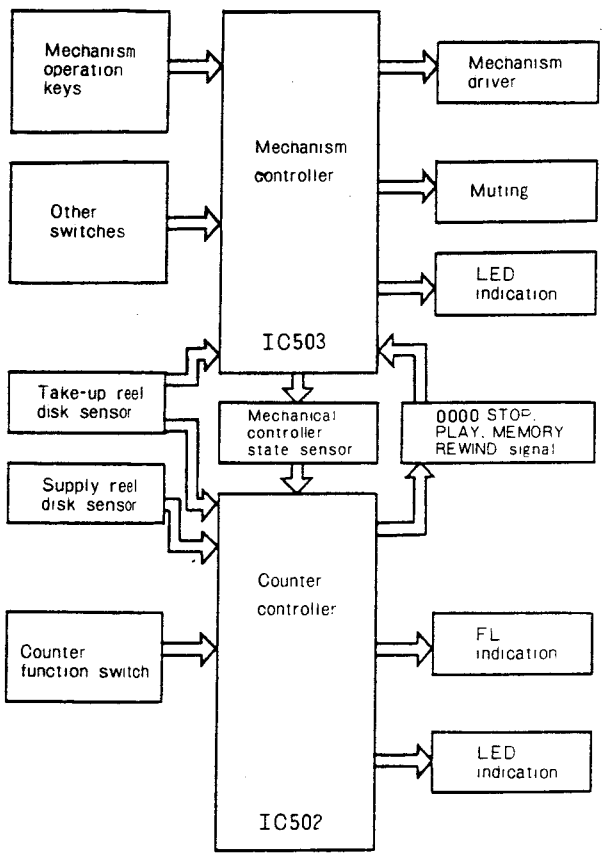

Fig-1

3. Mechanism controller specifications

- 3-1. General specifications**
 - 3-1-1. **STOP, PLAY, RWD, FF, REC, PLAY/PAUSE:** Same as the general controller
 - 3-1-2. **CUE, REVIEW:** Possible by pressing the PLAY key and FF (or RWD) key together.
 - 3-1-3. **ONE TOUCH REC:** It is set to the REC/PLAY-PAUSE mode by pressing only the REC key in the PAUSE mode.
 - 3-1-4. **TIMER-REC/PLAY:** Same as the general specifications
 - 3-1-5. **Counter 0000 STOP/PLAY, MEMORY-REWIND:** This cannot be operated when the remaining tape is displayed. This does not operate during the REC, MS, INTRO-PLAY operations.
 - 3-1-6. **AUTO-REC MUTE:** Same as the general specifications

3-2. Additional functions

- 3-2-1. **MS:** Same as general specifications
- 3-2-2. **INTRO PLAY:** By setting to CUE or REV with INTRO PLAY ON, it plays the first 8 seconds of each tune.
- 3-2-3. **ADMS:** ADMS is performed when the power is set to ON.

3-3. Description of microcomputer terminal

3-3-1. Terminal name (IC-503)

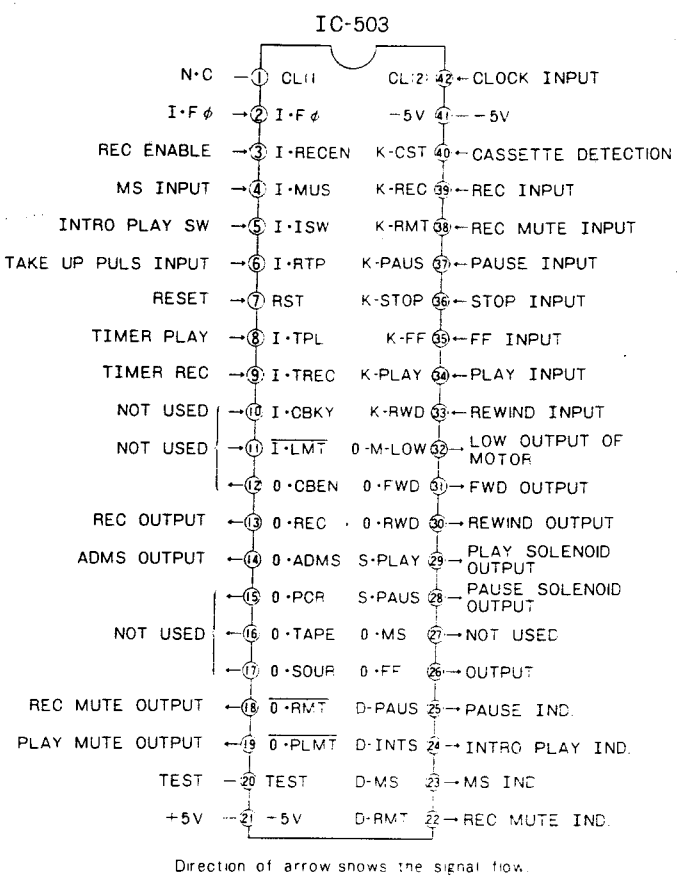

Fig-2

3-3-2. Terminal functions

"H": High level, 5V
 "L": Low level, 0 or -5V

Pin No.	Terminal symbol	Function
①	CL (1)	The clock receives only 400Hz from the counter microcomputer, so CL (1) is not used. Input: CL (2) only
④②	CL (2)	
②	I · Fφ	Terminal to inhibit ME.RWD during REC. Set to "L" from "H" when the RWD command is input from the microcomputer.
③	I · RECEN	The terminal is set to "L" and recording is not done when the safety tab is broken off.
④	I · MUS	Signal input during INTRO PLAY and MS. Set to "H" for tunes and to "L" between tunes.
⑤	I · ISW	Switch to select the INTRO PLAY and MS. Repeats OFF → INTRO PLAY → MS → OFF.
⑥	I · RTP	Inputs the pulse from the take-up reel disk sensor. For AUTO-STOP.

Pin No.	Terminal symbol	Function
⑦	RST	RESET terminal. Set to "H" instantaneously when power is switched ON; also set to "H" instantaneously when power is switched OFF. Set to "L" in general.
⑧	T · PL	Set to "H" during timer play and recording. Set to "L" during OFF.
⑨	T · REC	
⑩	I · CBKY	Not used in F660. Set terminal 10 to "L" and terminal 11 to "H".
⑪	I · LMT	
⑫	0 · CBEN	
⑬	0 · REC	Set to "H" during recording. For erase, bias oscillator.
⑭	0 · ADMS	Set to "H" for approx. 1.5sec during power ON. For ADMS.
⑮	0 · RCR	Not used in F660. OPEN terminal
⑯	0 · TAPE	
⑰	0 · SOUR	
⑱	0 · RMT	Set to "H" during recording, and "L" during REC-MUTE in recording.
⑲	0 · PLMT	Set to "H" during REC/PLAY, CUE/REV to release muting. Set to "L" during INTRO PLAY, MS.
⑳	TEST	Connect to +5V.
㉓ ~ ㉕	D- ...	Indication output. Set to "H" during operation.
㉖	0-FF	Set to "H" during FF, CUE.
㉘	S-PAUS	Set to "H" during PAUSE and CUE/REV.
㉙	S-PLAY	Set to "H" during PLAY/REC, CUE/REV.
㉚	0-RWD	Set to "H" during RWD/REV.
㉛	0-FWD	Set to "H" during REC/PLAY/FF/CUE.
㉜	0-M-LOW	Set to "H" during REC/PLAY.
㉞ ~ ㉟	K- ...	Key input. Set to "H" in general. Accepts key input when changed to "L" from "H".

Table-1

3-4. Description of solenoid circuit

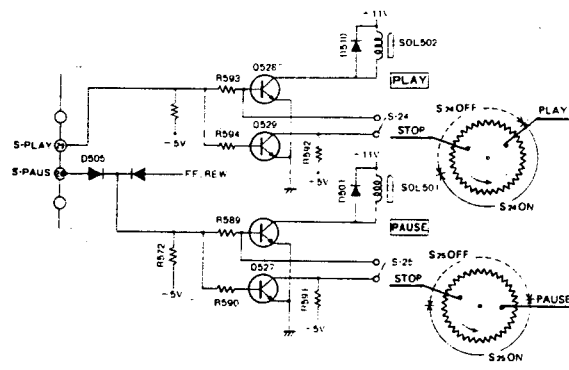

Fig-3

3-4-1. Description of PLAY solenoid: S-24 is set to OFF during the stop mode, and when the S-PLAY pin of the microcomputer is set to "H", Q528 is set to ON and SOL502 is pulled in. When SOL502 is pulled in, the gear PLAY cam turns and S-24 enters the ON region.

Q529 has been set to ON, so Q528 is set to ON simultaneously when S-24 is set to OFF and SOL502 is set to OFF. The gear PLAY cam continues turning when SOL502 is set to OFF and stops at the PLAY position. When the S-PLAY terminal is set to "L" from "H", Q529 is set to OFF, and the current flows to the Q528 base and SOL502 is set to ON again. The gear PLAY cam turns again and SOL502 is set to OFF when S-24 enters the OFF region but the gear PLAY cam turns to the STOP position.

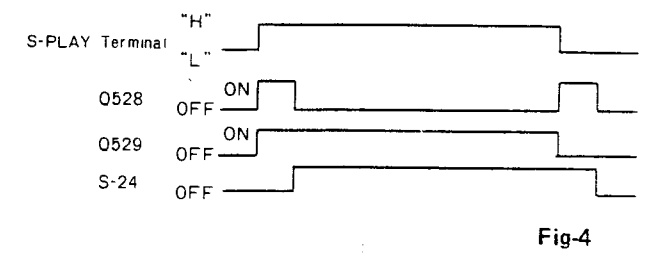

Fig-4

3-4-2. Description of PAUSE solenoid: The operation is same as that of the PLAY solenoid mechanism. The PAUSE operation also works to release braking applied to the reel disk, so SOL501 is set to ON during FF.RWD other than during PAUSE.

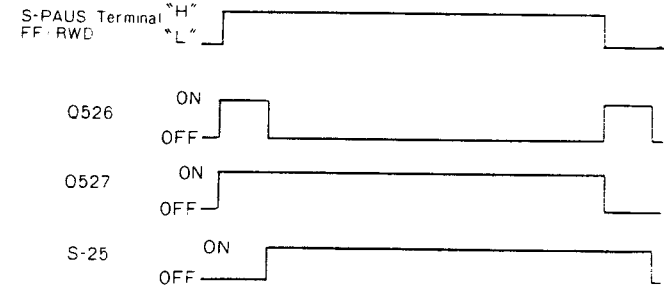

Fig-5

4. Counter controller specifications

4-1. Counter function

- 4-1-1. Addition and subtraction are same as with a general counter. However, when the eject operation is done, it is reset.
- 4-1-2. **MEMORY-RWD function:** 0000-STOP, REPLAY function is processed via this microcomputer and commands are transmitted to the controller.

4-2. Remaining tape function

- 4-2-1. The remaining tape is indicated in minute/second units during play/recording. When the unit enters the STOP and PAUSE modes while the remaining tape is displayed, the display is held.
- 4-2-2. When the unit enters the FF/RWD modes during minute/second indication, the residual amount time is indicated in minute units.

4-3. FL indication functions

- 4-3-1. The counter controller can be connected directly to the FL grid and plate and all the indication terminals are pulled down to -V-DIFP inside the micro-computer.

4-4. Desc

Pin No.	Function
①	C
②	0
③	0
④	0
⑤-⑧	C
⑨-⑬	G
⑭	V
⑮	R

4-4. Description of microcomputer terminal

4-4-1. Terminal name

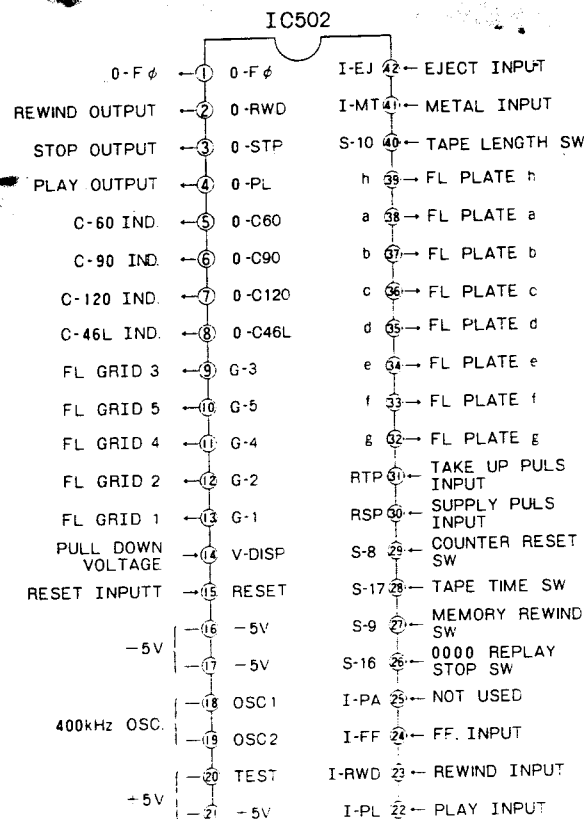

Direction of arrow shows the signal flow.

Fig-6

4-4-2. Terminal functions

"H": High level, +5V
"L": Low level, 0 or -5V

Pin No.	Terminal symbol	Function
①	0-Fφ	This is set to "L" in general and to "H" when 0-RWD, 0-STOP or 0-PL is output. This is used to discriminate between the key inputs of the mechanism controller.
②	0-RWD	"L" is output to perform memory-RWD in the counter mode. Set to "H" in general.
③	0-STP	"L" is output to perform 0000 STOP in the counter mode. Set to "H" in general.
④	0-PL	"L" is output to perform 0000 REPLAY in the counter mode. Set to "H" in general.
⑤-⑧	0-C...	This is used for TAPE LENGTH indication.
⑨-⑬	G...	Connected to the FL grid.
⑭	V-DISP	This terminal determines the internal pull-down potential.
⑮	RESET	Internal reset is possible. Reset is applied when this is connected to -5V.

Pin No.	Terminal symbol	Function
⑮, ⑰	-5V	-5V
⑱, ⑲	OSC	This is 400Hz ceramic oscillator.
⑳, ㉑	+5V	+5V
㉒	I-PL	"H" is input during play, record/play and the remaining minutes and seconds are calculated.
㉓	I-RWD	"H" is input during RWD, and the remaining tape in the RWD direction is calculated.
㉔	I-FF	"H" is input during FF and the remaining tape in the FF direction is calculated.
㉖-㉙	S...	Counter function input switch. Set to "L" in general, and "H" is input when the key is set to ON.
㉚	RSP	Inputs the pulse output from the supply reel disk. This is used to measure the time it takes the supply reel disk to complete 1 revolution during play.
㉛	RTP	Inputs the pulse output from the take-up reel. This is used for the counter.
㉜-㉞	a ~ h	Connected to the FL plate.
㉟	I-MT	Set to "L" in general and to "H" when METAL TAPE is used. The remaining tape is corrected for the thickness of METAL TAPE.
㊱	I-EJ	This is used to reset the counter to "0000" when the cassette is not inserted during the counter mode. The remaining amount is erased during EJECT in the remaining tape mode.

Table-2

4-5. Description of FL (Fluorescent lamp) counter

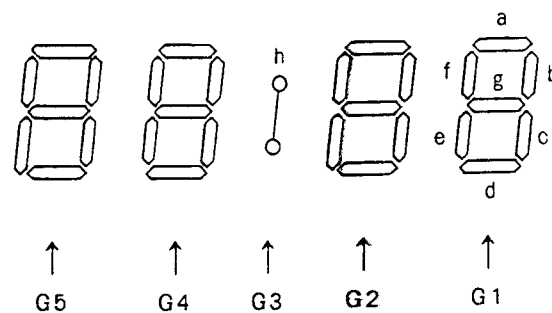

Fig-7

The filament voltage is approx. 1.5V.

4-6. Description of indication

4-6-1. Tape length indication

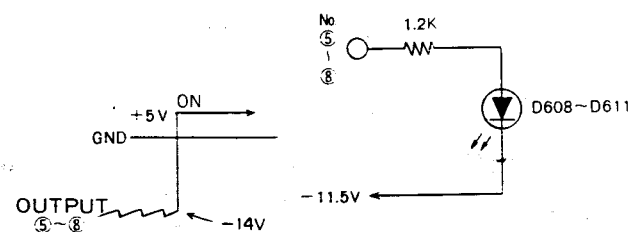

Fig-8

4-6-2. "0000" STOP, REPLAY, MEMORY REWIND indications:

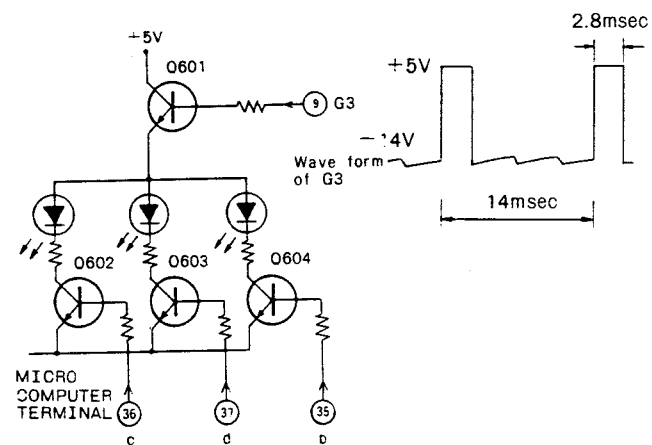

Fig-9

When terminal c is set to "H" while G-3 is set to "H", Q601 and Q602 are set to ON, and the 0000 REPLAY indicator LED lights.
When terminal b is set to "H" while G-3 is set to "H", Q601 and Q604 are set to ON, and the 0000 STOP indicator LED lights.
When terminal d is set to "H" while G-3 is set to "H", Q601 and Q603 are set to ON and the MEMORY REWIND indicator LED lights.
The current flowing to the LED is not DC at this time but the pulse frequency divided by 5.

5. Description of other functions

5-1. 0000 STOP, REPLAY, MEMORY REWIND functions during CUE/REW/MS operations:

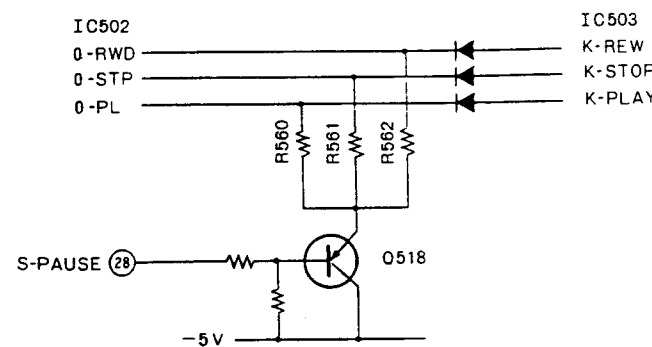

Fig-10

3 outputs of IC502 are not pulled-down when S-PAUSE is set to "H", so IC503 key input is not accepted.
When S-PAUSE is set to "L", the IC502 output is pulled down via R560 ~ 562 during operation and IC503 accepts the operation.

IC502 terminal 22 circuit description

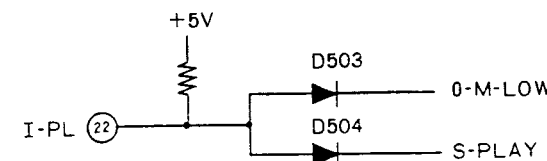

Fig-11

When S-PLAY is set to "H" and OM-LOW is also set to "H", "H" is input to I-PL.

set to OFF
LAY pin of
is set to ON
is pulled in,
ers the ON

o ON simul-
OL502 is set
rning when
AY position.
' from "H",
to the Q528

502 is set to
but the gear

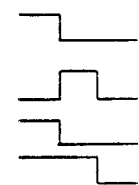

Fig-4

ation is same

lease braking
to ON during

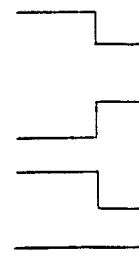

Fig-5

with a general
on is done, it

REPLAY
ter and com-

second units
ers the STOP
g tape is dis-

modes during
mount time is

ad directly to
tion terminals
e the micro-