

AIWA®

S/M Code No. 86-026
DATE OF ISSUE 6/1986-Z 340

SERVICE MANUAL

STEREO CASSETTE DECK

MODEL NO.

AD-F360, S15

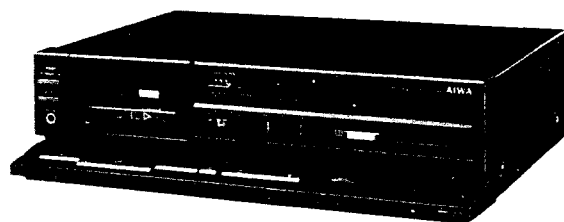

STEREO CASSETTE DECK

MODEL NO.

AD-R460, R30

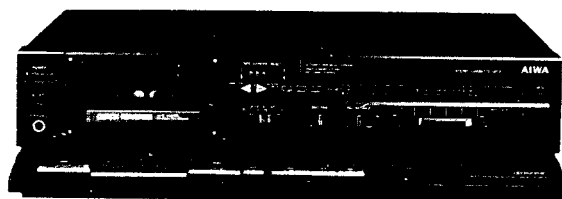

Basic mechanism 2ME-1 (AD-R460/R30), 2ME-4 (AD-F360/S15)

TYPE. HB, HJB, CB, EB, KB, GB, ZB (AD-F360)
UB (AD-S15)
HB, HJB, CB, EB, KB, GB, ZB (AD-R460)
UB (AD-R30)

Follow the instructions carefully, which will allow the user to optimise the products' performance and give many years of service.

- No scratch and melting shall be made to covered lead-wires of an a.c. primary circuit including mains leads.
- No illegibility shall be given to the specification plate, the caution labels, the fuse labels and others.
- When, on pattern sides of circuit boards, additional repair-parts have been made up, the parts shall be firmly glued to circuit boards or other components, unless the parts can be attached firmly.
- The following matters shall be maintained as they are, when repairing.
 - Soldering of lead-wire ends
 - * Care should be taken of the space distance in an a.c. primary circuit as well as soldering.
 - Wiring and holding of lead-wires with wire-clips and binders
 - Materials of lead-wires
 - * e.g.; For UL models, lead-wires to be used shall be approved or accepted by the UL.
 - Location of all kinds of insulators
 - Setting of voltage selector switch
 - * Set the Voltage Selector Switch to 240V, 220V, or 120V, According to your Local Voltage.
- After repaired, the insulation resistance or leakage current shall be measured with $500 \pm 5V$ D.C and shall be not less than $1M\Omega$.
- General instructions for mechanism repair
 - The heads, capstan and pinch roller shall be cleaned of good quality alcohol after repaired, because dirty heads shall cause distorted sounds while dirty capstan and pinch roller shall occur wow/flutter and take-up fault.
 - Lubricants been stained the surfaces of transmitting portion of the belts, idlers, capstan and pinch roller shall be removed, because slippery and faulty tape travel shall be caused.
 - When oiling, only one or two drops shall be applied so as not to run over and be dispersed. Note should be taken of the metal fitting for the capstan and rotating portions of the idlers and pinch roller, especially.
 - E-rings and poly slider washers shall be replaced with new ones, if once those have been removed. — No re-utilization due to unreliability.
 - Regular spare-parts shall always be used for repair, because using irregular parts and tampering with the products shall cause deterioration, malfunction and damage.

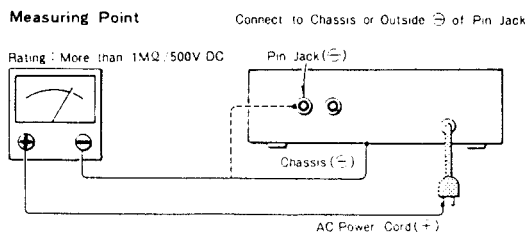

SPECIFICATIONS

AD-F360, S15

Type	Stereo cassette tape deck	Inputs	LINE IN maximum input sensitivity: 50 mV (over 50 k Ω)
Track format	4 tracks 2 channels		DIN max sensitivity (Z model only): 0.1 mV/k Ω (3.3 k Ω)
Power supply	AD-F360 E, Z AC 220 V, 50/60 Hz AD-F360 K, G AC 240 V, 50/60 Hz AD-S15 U, AD-F360 C AC 120 V, 60 Hz AD-F360 H AC 120 V/220 V—240 V switchable, 50/60 Hz	Outputs	LINE OUT standard output level: 0.41 V (0 VU); suitable load impedance: over 50 k Ω ; DIN standard level (Z model only): 0.41 V (0 VU) Headphones: 8~1 k Ω
Power consumption	17 W	Dimensions	420(W) \times 110(H) \times 295(D) mm
Frequency response	METAL tape: 20~17,000 Hz CrO ₂ position tape: 20~16,000 Hz NORMAL tape: 20~15,000 Hz	Weight	4.0 kg
Signal-to-noise ratio	73 dB (METAL tape DOLBY C NR ON)	Accessories	Stereo pin cord (2)
Wow and flutter	According to DIN 45 500 0.18% 0.065% (WRMS)		
Tape speed	4.8 cm/sec. (1-7/8 ips)		
Rewind time	90 sec. (C-60)		
Fast forward time	90 sec. (C-60)		
Recording system	AC bias (frequency 85 kHz)		
Erase system	AC erase		
Motor	DC Servomotor		
Head	Record/playback head \times 1 Erase head \times 1		

AD-R460, R30

Type	Stereo cassette tape deck	Inputs	LINE IN maximum input sensitivity: 50 mV (over 50 k Ω)
Track format	4 tracks 2 channels		DIN max sensitivity (Z model only): 0.1 mV/k Ω (3.3 k Ω)
Power supply	AD-R460 E, Z AC 220 V, 50/60 Hz AD-R460 K, G AC 240 V, 50/60 Hz AD-R460 C, AD-R30 U AC 120 V, 60 Hz AD-R460 H AC 120 V/220 V—240 V switchable, 50/60 Hz	Outputs	LINE OUT standard output level: 0.4 V (0 VU); suitable load impedance: over 50 k Ω ; DIN standard level (Z model only): 0.4 V (0 VU) Headphones: 8 Ω —1 k Ω
Power consumption	17 W	Dimensions	420(W) \times 110(H) \times 295(D) mm
Frequency response	METAL tape: 20—17,000 Hz CrO ₂ position tape: 20—16,000 Hz NORMAL tape: 20—15,000 Hz	Weight	4.0 kg
Signal-to-noise ratio	73 dB (METAL tape DOLBY C NR ON)	Accessories	Stereo pin cord \times 2
Wow and flutter	According to DIN 45 500 0.18% 0.065% (WRMS)		
Tape speed	4.8 cm/sec. (1-7/8 ips)		
Rewind time	90 sec. (C-60)		
Fast forward time	90 sec. (C-60)		
Recording system	AC bias (frequency 85 kHz)		
Erase system	AC erase		
Motor	DC Servomotor \times 1		
Head	Record/playback head \times 1 Erase head \times 1		

- Design and specifications are subject to change without notice.
- Noise reduction system manufactured under license from Dolby Laboratories Licensing Corporation.
- Dolby and the  symbol are trademarks of Dolby Laboratories Licensing Corporation.

CAPACITORS COILS FUSE
 No mark, U, UF: μ F MMH: mH MMA: mA
 P, PF : pF UH : μ H

ELECTRICAL MAIN PARTS LIST (AD-R460, R30U)

- +++ mark denotes a component of assembled part which part code is represented by a previously stated component.
- *mark means less required items and availabilities may be limited.

Ref. No.	Part No.	Description	Ref.No.	Part No.	Description
=== IC ===					
	87-020-454	IC,DM6851	C652	* 87-010-374	CAP,ELECT 47/10
	87-020-489	iC, 1R2E19	C653	* 87-010-374	CAP,ELECT 47/10
	87-020-080	IC,L78N12	D201	* 87-027-376	DIODE 1N4B41
	87-020-261	IC,LA6358S	D301	87-020-110	DIODE 1SS177
	82-146-642	IC,LM6402G-572	D302	87-020-110	DIODE 1SS177
	87-027-895	IC,M5218L	D401	87-020-110	DIODE 1SS177
	87-027-554	IC,UPD4066	D402	87-020-110	DIODE 1SS177
			D406	87-020-110	DIODE 1SS177
=== TRANSISTOR ===					
	89-109-521	TRANSISTOR,2SA952 K	D602	87-020-123	DIODE DS446
	89-109-705	TRANSISTOR,2SA970 GR,BL	D603	87-020-123	DIODE DS446
	89-110-154	TRANSISTOR,2SA1015 Y,GR	D604	87-020-123	DIODE DS446
	89-309-457	TRANSISTOR,2SC945 L,K	△ FR201	* 87-029-066	RES,FUSIBLE 1.5 1/2W
	89-309-455	TRANSISTOR,2SC945 PQ	L351	* 82-135-631	COIL FILTER TRAP 85K
	89-309-452	TRANSISTOR,2SC945 Q,R	L352	* 82-135-631	COIL FILTER TRAP 85K
	89-318-155	TRANSISTOR,2SC1815 GR	L353	* 87-003-128	COIL MICRO INDUCTOR 5.6MMH
	89-318-154	TRANSISTOR,2SC1815 Y,GR	L354	* 87-003-128	COIL MICRO INDUCTOR 5.6MMH
	89-320-011	TRANSISTOR,2SC2001 K	L401	* 82-194-632	COIL OSC BIAS 85K
	89-322-405	TRANSISTOR,2SC2240 GR,BL	L402	* 87-005-214	COIL MICRO INDUCTOR 330UH
	89-408-805	TRANSISTOR,2SD880 GR	L601	* 82-189-642	COIL OSC LM6400
	89-413-023	TRANSISTOR,2SD1302 S,T	R303	* 87-025-402	RES,MFO 100K 1/8W
			R304	* 87-025-402	RES,MFO 100K 1/8W
			RY401	87-045-237	RELAY GSA-237P
			SFR301*	87-021-739	SFR 2.2K
			SFR302*	87-021-739	SFR 2.2K
			SFR303*	87-021-738	SFR 1K
			SFR304*	87-021-738	SFR 1K
			SFR351*	87-021-741	SFR 4.7K
			SFR352*	87-021-741	SFR 4.7K
			SFR401*	87-021-746	SFR 100K
			SFR402*	87-021-746	SFR 100K
=== MAIN CIRCUIT BOARD SECTION ===					
PCB-A	82-148-609	MAIN CIRCUIT BOARD			
C202	* 89-663-815	CAP,CERA-SOL 0.01 (EXCEPT Z)			
C203	* 89-663-815	CAP,CERA-SOL 0.01 (EXCEPT Z)			
C205	* 87-010-232	CAP,ELECT 220/16			
C206	* 87-010-049	CAP,ELECT 330/25 (105)			
C207	* 87-010-263	CAP,ELECT 100/10			
C208	* 87-010-379	CAP,ELECT 22/16 SME			
C209	* 87-010-379	CAP,ELECT 22/16 SME			
C301	* 87-018-039	CAP,CERA-SOL 390P			
C302	* 87-018-039	CAP,CERA-SOL 390P			
C303	* 87-018-040	CAP,CERA-SOL 470P			
C304	* 87-018-040	CAP,CERA-SOL 470P			
C307	* 87-010-374	CAP,ELECT 47/10			
C308	* 87-010-374	CAP,ELECT 47/10			
C309	* 87-018-039	CAP,CERA-SOL 390P			
C310	* 87-018-039	CAP,CERA-SOL 390P			
C313	* 87-010-404	CAP,ELECT 4.7/50 SME			
C314	* 87-010-404	CAP,ELECT 4.7/50 SME			
C331	* 87-010-112	CAP,ELECT 100/16			
C351	* 87-010-263	CAP,ELECT 100/10			
C353	* 87-010-374	CAP,ELECT 47/10			
C354	* 87-010-374	CAP,ELECT 47/10			
C365	* 87-010-404	CAP,ELECT 4.7/50 SME			
C366	* 87-010-404	CAP,ELECT 4.7/50 SME			
C401	* 87-018-034	CAP,CERA-SOL 150P			
C402	* 87-018-034	CAP,CERA-SOL 150P			
C403	* 87-014-071	CAP,PP 3900P			
C404	* 87-010-379	CAP,ELECT 22/16 SME			
C407	* 87-010-404	CAP,ELECT 4.7/50 SME			
C408	* 87-010-404	CAP,ELECT 4.7/50 SME			
C501	* 87-010-231	CAP,ELECT 220/10 KS			
C502	* 87-010-231	CAP,ELECT 220/10 KS			
C505	* 87-010-379	CAP,ELECT 22/16 SME			
C506	* 87-010-379	CAP,ELECT 22/16 SME			
C531	* 87-010-379	CAP,ELECT 22/16 SME			
C601	* 87-018-044	CAP,CERA-SOL 1000P			
C602	* 87-010-429	CAP,ELECT 680/16 SME			
C603	* 87-010-429	CAP,ELECT 680/16 SME			
C651	* 87-010-400	CAP,ELECT 0.47/50 SME			
=== DISPLAY CIRCUIT BOARD SECTION ===					
PCB-B	*	DISPLAY CIRCUIT BOARD			
C805	* 87-010-401	CAP,ELECT 1/50			
C806	* 87-010-401	CAP,ELECT 1/50			
C807	* 87-010-379	CAP,ELECT 22-16 SME			
C808	* 87-010-379	CAP,ELECT 22-16 SME			
C809	* 87-010-403	CAP,ELECT 3.3/50 SME			
D801	* 87-027-542	LED LN217RP (PEAK METER,+10)			
D802	* 87-027-542	LED LN217RP (PEAK METER,+10)			
D803	* 87-027-542	LED LN217RP (PEAK METER,+6)			
D804	* 87-027-542	LED LN217RP (PEAK METER,+6)			
D805	* 87-027-542	LED LN217RP (PEAK METER,+3)			
D806	* 87-027-542	LED LN217RP (PEAK METER,+3)			
D807	* 87-027-543	LED LN317GP (PEAK METER,0)			
D808	* 87-027-543	LED LN317GP (PEAK METER,0)			
D809	* 87-027-543	LED LN317GP (PEAK METER,-3)			
D810	* 87-027-543	LED LN317GP (PEAK METER,-3)			
D811	* 87-027-543	LED LN317GP (PEAK METER,-7)			
D812	* 87-027-543	LED LN317GP (PEAK METER,-7)			
D813	* 87-027-543	LED LN317GP (PEAK METER,-20)			
D814	* 87-027-543	LED LN317GP (PEAK METER,-20)			
D815	* 87-027-543	LED LN317GP (PEAK METER,∞)			
D816	* 87-027-543	LED LN317GP (PEAK METER,∞)			
D817	* 87-020-686	LED SG232D (DOLBY B-TYPE)			
D818	* 87-020-684	LED SR632D (DOLBY C-TYPE)			
D819	* 87-020-684	LED SR632D (TAPE TYPE-METAL)			
D820	* 87-020-685	LED SY432D (TAPE TYPE-CO)			
D821	* 87-020-686	LED SG232D (TAPE TYPE-NORMAL)			
D822	* 87-020-142	LED SLP984A-51 (REVERSE MODE ⇐)			
D823	* 87-020-142	LED SLP984A-51 (REVERSE MODE ⇐)			
D824	* 87-020-142	LED SLP984A-51 (REVERSE MODE ⇐)			
D825	87-020-110	DIODE 1SS177			
D826	* 87-020-744	LED 350GP-LS (DIRECTION ⇐)			

Ref. No.	Part No.	Description	Ref. No.	Part No.	Description
D827	★ 87-020-744	LED 350GP-LS (DIRECTION ►)	C959	★ 87-010-401	CAP,ELECT 1/50 (Z ONLY)
D830	87-020-110	DIODE 1SS177	C960	★ 87-010-401	CAP,ELECT 1/50 (Z ONLY)
D831	87-020-110	DIODE 1SS177	D901	87-020-110	DIODE 1SS177
D832	87-020-110	DIODE 1SS177	D902	87-020-110	DIODE 1SS177
L801	★ 87-008-318	COIL MPX FILTER	D951	87-020-123	DIODE DS446 (Z ONLY)
S801	87-031-807	SLIDE SW 2-2-3 (DOLBY B-C NR)	J901-1	87-049-355	JACK PIN 4P-17 (LINE IN/REC)
VR801	82-148-620	VOLUME SR 50KA X2 L5 (REC LEVEL)	J901-2	+++	JACK PIN 4P-17 (LINE IN/REC)
VR802	82-199-632	VOLUME 250KW (BALANCE)	J901-3	+++	JACK PIN 4P-17 (LINE OUT/PLAY)
VR803	82-197-632	VOLUME H0 50KB CC (BIAS FINE)	J901-4	+++	JACK PIN 4P-17 (LINE OUT/PLAY)
=== POWER CIRCUIT BOARD SECTION ===			J951	87-049-079	JACK DIN 5P (REC/PLAY) (Z ONLY)
PCB-C	*	POWER CIRCUIT BOARD	RY951	87-045-202	RELAY LEAD (Z ONLY)
C551	★ 87-010-381	CAP,ELECT 330/16 SME	S951	87-031-752	SLIDE SW (INPUT SELECT.)(Z ONLY)
C552	★ 87-018-134	CAP,CERA-SOL SS 0,01	=== TERMINAL CIRCUIT BOARD SECTION ===		
C553	★ 87-012-105	CAP,CERA-SOL 0,022	PCB-F	*	TERMINAL CIRCUIT BOARD (E,K,Z,G ONLY)
C554	★ 87-012-105	CAP,CERA-SOL 0,022	=== DECK CIRCUIT BOARD SECTION ===		
C555	★ 87-010-374	CAP,ELECT 47/10	PCB-G	*	DECK CIRCUIT BOARD
C556	★ 87-010-374	CAP,ELECT 47/10	S101	86-517-621	LEAF SW (CAST)
C557	★ 87-010-400	CAP,ELECT 0.47/50 SME	S102	86-517-621	LEAF SW (ENA A)
C558	★ 87-010-400	CAP,ELECT 0.47/50 SME	S103	86-517-612	LEAF SW (ENA B)
J551	87-049-394	JACK 6,3 (PHONES)	S104	87-031-374	LEAF SW (DIRECT)
S551	82-148-621	PUSH SW 2-2-2 (POWER)	S105	86-517-621	LEAF SW (MT)
=== KEY SWITCH CIRCUIT BOARD SECTION ===			S106	86-517-621	LEAF SW (CO)
PCB-D	*	KEY SWITCH CIRCUIT BOARD	SCL101	86-517-611	SOLENOID 2ME-1A
D851	87-020-110	DIODE 1SS177	SOL102	86-517-612	SOLENOID 2ME-1B
D852	87-020-110	DIODE 1SS177	=== SENSOR CIRCUIT BOARD SECTION ===		
D853	87-020-110	DIODE 1SS177	PCB-H	*	SENSOR CIRCUIT BOARD
D854	87-020-110	DIODE 1SS177	CP101	87-020-457	PHOTO SENSOR NJL-5144L-B
D855	87-020-110	DIODE 1SS177	=== DOLBY-NR CIRCUIT BOARD SECTION ===		
D856	87-020-110	DIODE 1SS177	87-020-132 DOLBY UNIT HA-12058J (W/PCB-1)		
D857	87-020-110	DIODE 1SS177	=== MISCELLANEOUS ===		
D858	87-020-110	DIODE 1SS177	▲	★ 87-085-184	AC CORD BUSHING D (H,U,C ONLY)
D859	87-020-110	DIODE 1SS177	▲	★ 87-085-185	AC CORD BUSHING E (E,K,Z G ONLY)
D860	87-020-110	DIODE 1SS177	▲	★ 87-034-732	AC CORD H (H ONLY)
D861	87-020-110	DIODE 1SS177	▲	★ 87-034-578	AC CORD U (U,C ONLY)
D862	87-020-110	DIODE 1SS177	▲	★ 82-187-797	AC CORD EE (E,Z ONLY)
D863	87-020-110	DIODE 1SS177	▲	★ 82-187-796	AC CORD K (K ONLY)
D864	★ 87-020-169	LED SLP277B (REVERSE PLAY)	▲	★ 82-187-795	AC CORD AS (G ONLY)
D865	★ 87-020-169	LED SLP277B (PLAY)	▲	87-033-140	SPLICE CONNECTOR (H,U,C ONLY)
D866	★ 87-020-170	LED SLP477B (PAUSE)	82-148-633 CONNECTOR ASSY RVS HEAD		
D867	★ 87-020-168	LED SLP177B (REC MUTE)	M101	87-045-238	MOTOR DC MMA-6BZLA
D868	★ 87-020-168	LED SLP177B (RECORD)	▲PT1	82-143-611	POWER TRANSFORMER H (H ONLY)
S851	87-031-771	TACT SW (◀▶)	▲PT1	82-143-612	POWER TRANSFORMER (U,C ONLY)
S852	87-031-771	TACT SW (REVERSE PLAY)	▲PT1	82-143-613	POWER TRANSFORMER E (E,Z ONLY)
S853	87-031-771	TACT SW (PLAY)	▲PT1	82-143-614	POWER TRANSFORMER K (K,G ONLY)
S854	87-031-771	TACT SW (▶▶)	RPEH	87-046-259	RP/E HEAD HD425820
S855	87-031-771	TACT SW (STOP)	S1	87-031-353	ROTARY SW (AC VOLTAGE) (H ONLY)
S856	87-031-771	TACT SW (PAUSE)			
S857	87-031-771	TACT SW (REC MUTE)			
S858	87-031-771	TACT SW (RECORD)			
S859	87-031-807	SLIDE SW 2-2-3 (REVERSE MODE)			
S860	87-031-807	SLIDE SW 2-2-3 (TIMER)			
=== DIN PIN CIRCUIT BOARD SECTION ===					
PCB-E	*	DIN PIN CIRCUIT BOARD			
C951	★ 87-010-260	CAP,ELECT 47/25 (Z ONLY)			
C953	★ 87-010-400	CAP,ELECT 0.47/50 SME (Z ONLY)			
C954	★ 87-010-400	CAP,ELECT 0.47/50 SME (Z ONLY)			
C955	★ 87-018-012	CAP,CERA-SOL 15P J (Z ONLY)			
C956	★ 87-018-012	CAP,CERA-SOL 15P J (Z ONLY)			
C957	★ 87-018-089	CAP,CERA-SOL 470P (Z ONLY)			
C958	★ 87-018-089	CAP,CERA-SOL 470P (Z ONLY)			

CAPACITORS COILS FUSE
 No mark, U, UF: μ F MMH: mH MMA: mA
 P, PF : pF UH : μ H

- +++ mark denotes a component of assembled part which part code is represented by a previously stated component.
- * -mark means less required items and availabilities may be limited.

ELECTRICAL MAIN PARTS LIST (AD-F360, F15U)

Ref. No.	Part No.	Description	Ref. No.	Part No.	Description
=== IC ===			D302	87-020-110	DIODE 1SS177
	87-020-454	IC, DM6851	D401	87-020-110	DIODE 1SS177
	87-020-489	IC, IR2E19	D402	87-020-110	DIODE 1SS177
	87-020-080	IC, L78N12	D406	87-020-110	DIODE 1SS177
	82-146-642	IC, LM6402G-572	D602	87-020-123	DIODE DS446
	87-027-895	IC, M5218L	D603	87-020-123	DIODE DS446
	87-027-554	IC, UPD4066	D604	87-020-123	DIODE DS446
			ΔFR201	* 87-029-066	RES, FUSIBLE 1.5 1/2W
=== TRANSISTOR ===			L351	* 82-135-631	COIL FILTER TRAP 85K
	89-109-521	TRANSISTOR, 2SA952 K	L352	* 82-135-631	COIL FILTER TRAP 85K
	89-109-705	TRANSISTOR, 2SA970 GR, BL	L353	* 87-003-128	COIL MICRO INDUCTOR 5.6MMH
	89-110-154	TRANSISTOR, 2SA1015 Y, GR	L354	* 87-003-128	COIL MICRO INDUCTOR 5.6MMH
	89-309-457	TRANSISTOR, 2SC945 L, K	L401	* 82-194-632	COIL OSC BIAS 85K
	89-309-455	TRANSISTOR, 2SC945 PQ	L402	* 87-005-214	COIL MICRO INDUCTOR 330UH
	89-309-452	TRANSISTOR, 2SC945 Q, R	L601	* 82-189-642	COIL OSC LM6400
	89-318-155	TRANSISTOR, 2SC1815 GR	R303	* 87-025-402	RES, MFO 100K 1/8W
	89-318-154	TRANSISTOR, 2SC1815 Y, GR	R304	87-025-402	RES, MFO 100K 1/8W
	89-320-011	TRANSISTOR, 2SC2001 K	RY401	87-045-237	RELAY GSA-237P
	89-322-405	TRANSISTOR, 2SC2240 GR, BL	SFR301*	87-021-739	SFR 2.2K
	89-408-805	TRANSISTOR, 2SD880 GR	SFR302*	87-021-739	SFR 2.2K
	89-413-023	TRANSISTOR, 2SD1302 S, T	SFR303*	87-021-738	SFR 1K
			SFR304*	87-021-738	SFR 1K
			SFR351*	87-021-741	SFR 4.7K
			SFR352*	87-021-741	SFR 4.7K
=== MAIN CIRCUIT BOARD SECTION ===			SFR401*	87-021-746	SFR 100K
PCB-A	82-148-609	MAIN CIRCUIT BOARD	SFR402*	87-021-746	SFR 100K
C202	* 89-663-815	CAP, CERA-SOL 0.01	=== DISPLAY CIRCUIT BOARD SECTION ===		
C203	* 89-663-815	CAP, CERA-SOL 0.01	PCB-B	*	DISPLAY CIRCUIT BOARD
C205	* 87-010-232	CAP, ELECT 220/16	C805	* 87-010-401	CAP, ELECT 1/50
C206	* 87-010-049	CAP, ELECT 330/25 (105)	C806	* 87-010-401	CAP, ELECT 1/50
C207	* 87-010-263	CAP, ELECT 100/10	C807	* 87-010-379	CAP, ELECT 22-16 SME
C208	* 87-010-379	CAP, ELECT 22/16 SME	C808	* 87-010-379	CAP, ELECT 22-16 SME
C209	* 87-010-379	CAP, ELECT 22/16 SME	C809	* 87-010-403	CAP, ELECT 3.3/50 SME
C301	* 87-018-039	CAP, CERA-SOL 390P	D801	* 87-027-542	LED LN217RP (PEAK METER, +10)
C302	* 87-018-039	CAP, CERA-SOL 390P	D802	* 87-027-542	LED LN217RP (PEAK METER, +10)
C303	* 87-018-040	CAP, CERA-SOL 470P	D803	* 87-027-542	LED LN217RP (PEAK METER, +5)
C304	* 87-018-040	CAP, CERA-SOL 470P	D804	* 87-027-542	LED LN217RP (PEAK METER, +5)
C307	* 87-010-374	CAP, ELECT 47/10	D805	* 87-027-542	LED LN217RP (PEAK METER, +3)
C308	* 87-010-374	CAP, ELECT 47/10	D806	* 87-027-542	LED LN217RP (PEAK METER, +3)
C309	* 87-018-039	CAP, CERA-SOL 390P	D807	* 87-027-543	LED LN317GP (PEAK METER, 0)
C310	* 87-018-039	CAP, CERA-SOL 390P	D808	* 87-027-543	LED LN317GP (PEAK METER, 0)
C313	* 87-010-404	CAP, ELECT 4.7/50 SME	D809	* 87-027-543	LED LN317GP (PEAK METER, -3)
C314	* 87-010-404	CAP, ELECT 4.7/50 SME	D810	* 87-027-543	LED LN317GP (PEAK METER, -3)
C331	* 87-010-112	CAP, ELECT 100/16	D811	* 87-027-543	LED LN317GP (PEAK METER, -7)
C351	* 87-010-263	CAP, ELECT 100/10	D812	* 87-027-543	LED LN317GP (PEAK METER, -7)
C353	* 87-010-374	CAP, ELECT 47/10	D813	* 87-027-543	LED LN317GP (PEAK METER, -20)
C354	* 87-010-374	CAP, ELECT 47/10	D814	* 87-027-543	LED LN317GP (PEAK METER, -20)
C365	* 87-010-404	CAP, ELECT 4.7/50 SME	D815	* 87-027-543	LED LN317GP (PEAK METER, ∞)
C366	* 87-010-404	CAP, ELECT 4.7/50 SME	D816	* 87-027-543	LED LN317GP (PEAK METER, ∞)
C401	* 87-018-034	CAP, CERA-SOL 150P	D817	* 87-029-686	LED SG232D (DOLBY B-TYPE)
C402	* 87-018-034	CAP, CERA-SOL 150P	D818	* 87-020-684	LED SR632D (DOLBY C-TYPE)
C403	* 87-014-071	CAP, PP 3900P	D819	* 87-020-684	LED SR632D (TAPE TYPE-MET, L)
C404	* 87-010-379	CAP, ELECT 22/16 SME	D820	* 87-020-685	LED SY432D (TAPE TYPE-CO)
C407	* 87-010-404	CAP, ELECT 4.7/50 SME	D821	* 87-020-686	LED SG232D (TAPE TYPE-NORMAL)
C408	* 87-010-404	CAP, ELECT 4.7/50 SME	D830	87-020-110	DIODE 1SS177
C501	* 87-010-231	CAP, ELECT 220/10 KS	D831	87-020-110	DIODE 1SS177
C502	* 87-010-231	CAP, ELECT 220/10 KS	D832	87-020-110	DIODE 1SS177
C505	* 87-010-379	CAP, ELECT 22/16 SME	L801	* 87-008-318	COIL MPX FILTER
C506	* 87-010-379	CAP, ELECT 22/16 SME	S801	87-031-807	SLIDE SW 2-2-3 (DOLBY B-C NR)
C531	* 87-010-379	CAP, ELECT 22/16 SME	VR801	82-148-620	VOLUME SR 50KA X2 L5 (REC LEVEL)
C601	* 87-018-044	CAP, CERA-SOL 1000P	VR802	82-199-632	VOLUME 250KW (BALANCE)
C602	* 87-010-429	CAP, ELECT 680/16 SME	VR803	82-197-632	VOLUME HO 50KB CC (BIAS FINE)
C603	* 87-010-429	CAP, ELECT 680/16 SME			
D201	* 87-027-376	DIODE 1N4B41			
D301	87-020-110	DIODE 1SS177			

Ref. No.	Part No.	Description	Ref. No.	Part No.	Description
----------	----------	-------------	----------	----------	-------------

=== POWER CIRCUIT BOARD SECTION ===

PCB-C	*	POWER CIRCUIT BOARD
C551	★ 87-010-381	CAP,ELECT 330/16 SME
C552	★ 87-018-134	CAP,CERA-SOL SS 0.01
C553	★ 87-012-105	CAP,CERA-SOL 0.022
C554	★ 87-012-105	CAP,CERA-SOL 0.022
C555	★ 87-010-374	CAP,ELECT 47/10
C556	★ 87-010-374	CAP,ELECT 47/10
C557	★ 87-010-400	CAP,ELECT 0.47/50 SME

C558	★ 87-010-400	CAP,ELECT 0.47/50 SME
J551	87-049-394	JACK 6.3 (PHONES)
S551	82-148-621	PUSH SW 2-2-2 (POWER)

=== KEY SWITCH CIRCUIT BOARD SECTION ===

PCB-D	*	KEY SWITCH CIRCUIT BOARD
D806	★ 87-020-170	LED SLP477B (PAUSE)
D851	87-020-110	DIODE 1SS177
D853	87-020-110	DIODE 1SS177
D854	87-020-110	DIODE 1SS177
D855	87-020-110	DIODE 1SS177
D856	87-020-110	DIODE 1SS177
D857	87-020-110	DIODE 1SS177
D858	87-020-110	DIODE 1SS177
D861	87-020-110	DIODE 1SS177
D862	87-020-110	DIODE 1SS177
D863	87-020-110	DIODE 1SS177

D865	★ 87-020-169	LED SLP277B (PLAY)
D867	★ 87-020-168	LED SLP177B (REC MUTE)
D868	★ 87-020-168	LED SLP177B (RECORD)
S851	87-031-771	TACT SW (◀▶)

S853	87-031-771	TACT SW (PLAY)
S854	87-031-771	TACT SW (▶▶)
S855	87-031-771	TACT SW (STOP)
S856	87-031-771	TACT SW (PAUSE)

S857	87-031-771	TACT SW (REC MUTE)
S858	87-031-771	TACT SW (RECORD)
S860	87-031-807	SLIDE SW 2-2-3 (TIMER)

=== DIN PIN CIRCUIT BOARD SECTION ===

PCB-E	*	DIN PIN CIRCUIT BOARD
C951	★ 87-010-260	CAP,ELECT 47/25 (Z ONLY)
C953	★ 87-010-400	CAP,ELECT 0.47/50 SME (Z ONLY)
C954	★ 87-010-400	CAP,ELECT 0.47/50 SME (Z ONLY)

C955	★ 87-018-012	CAP,CERA-SOL 15P J (Z ONLY)
C956	★ 87-018-012	CAP,CERA-SOL 15P J (Z ONLY)
C957	★ 87-018-089	CAP,CERA-SOL 470P (Z ONLY)
C958	★ 87-018-089	CAP,CERA-SOL 470P (Z ONLY)

C959	★ 87-010-401	CAP,ELECT 1/50 (Z ONLY)
C960	★ 87-010-401	CAP,ELECT 1/50 (Z ONLY)
D901	87-020-110	DIODE 1SS177
D902	87-020-110	DIODE 1SS177

D951	87-020-123	DIODE DS446 (Z ONLY)
J901-1	87-049-055	JACK PIN 4P-17 (LINE IN/REC)
J901-2	+++	JACK PIN 4P-17 (LINE IN/REC)
J901-3	+++	JACK PIN 4P-17 (LINE OUT/PLAY)
J901-4	+++	JACK PIN 4P-17 (LINE OUT/PLAY)
J951	87-049-079	JACK DIN 5P (REC/PLAY) (Z ONLY)
RY951	87-045-202	RELAY LEAD (Z ONLY)
S951	87-031-752	SLIDE SW (INPUT SELECT.)(Z ONLY)

=== TERMINAL CIRCUIT BOARD SECTION ===

PCB-F	*	TERMINAL CIRCUIT BOARD (E,K,Z,G ONLY)
-------	---	---------------------------------------

=== DOLBY-NR CIRCUIT BOARD SECTION ===

87-020-132	DOLBY UNIT HA-12058J (W/PCB-I)
------------	--------------------------------

=== DECK CIRCUIT BOARD SECTION ===

PCB-G	*	DECK CIRCUIT BOARD
S101	86-517-621	LEAF SW (CAST)
S102	86-517-621	LEAF SW (ENA A)
S105	86-517-621	LEAF SW (MT)
S106	86-517-621	LEAF SW (CO)
SOL101	86-517-611	SOLENOID 2ME-1A
SOL102	86-517-612	SOLENOID 2ME-1B

=== MISCELLANEOUS ===

△	★ 87-085-184	AC CORD BUSHING D (H,U,C ONLY)
△	★ 87-085-185	AC CORD BUSHING E (E,K,Z,G ONLY)
△	★ 87-034-732	AC CORD H (H ONLY)
△	★ 87-034-578	AC CORD U (U,C ONLY)
△	★ 82-187-797	AC CORD EE (E,Z ONLY)
△	★ 82-187-796	AC CORD K (K ONLY)
△	★ 82-187-795	AC CORD AS (G ONLY)
△	82-149-641	CONNECTOR ASSY HEAD 9P
M101	87-045-238	MOTOR DC MMA-6BZLA
△ PT1	82-143-611	POWER TRANSFORMER H (H ONLY)
△ PT1	82-143-612	POWER TRANSFORMER UC (U,C ONLY)
△ PT1	82-143-613	POWER TRANSFORMER E (E,Z ONLY)
△ PT1	82-143-614	POWER TRANSFORMER K (K,G ONLY)
RPH	87-046-243	RP HEAD
EH	87-046-196	E HEAD
△ S1	87-031-853	ROTARY SW (AC VOLTAGE) (H ONLY)

Note; Combination Circuit Board

The parts on the electrical parts list which are indicated by an asterisk (*) are supplied as one single combined circuit board. Therefore, they will not be supplied separately. If this becomes necessary, please order the entire circuit board.

Combination circuit board 82-148-610

PCB-B	82-148-613
PCB-C	82-148-612
PCB-D	82-148-611
PCB-E	82-148-614
PCB-F	82-148-615 (E, K, Z ONLY)

Combination circuit board 86-517-601

PCB-G	86-517-602
PCB-H	86-517-603 (AD-R460/R30U ONLY)

IC handling precaution

IC's construction makes this part susceptible to damage by static electricity and so take sufficient care in regard to following articles.

1. Need to be put on conductive sheet, to be put in a metallic box and to be wrapped by aluminium foil for transportation and deposit.
2. To use solder iron less than 40W (less than 260°C) of power consumption for soldering. But do not overheat more than 10 second.
3. Do not perform a conductivity test with a tester, etc. Refer to the circuit voltages of each part.

△ Safety component symbol

This symbol is given to important parts which serve to maintain the safety of the product, and which are made to conform to special safety specifications.

Therefore, when replacing a component with this symbol, make absolutely sure that you use a designated part.

• ADJUSTMENT (AD-F360/S15U, AD-R460/R30U)

A MAIN C.B

2. Playback Sensitivity Adjustment

- Settings:
- Test tape: TTA-161
 - Test point: J 901-3 (Lch)
J 901-4 (Rch)
 - Dolby NR SW: OFF
 - Adjustment location:

SFR 301 (Lch)
SFR 302 (Rch)

Method: Playback the test tape, then adjust so that the output is $490\text{mV} \pm 10\text{mV}$.

5. REC/PB Frequency Response Adjustment

- Settings:
- Test tape: TTA-119 J
 - Test point: J 901-3 (Lch)
J 901-4 (Rch)
 - Dolby NR SW: OFF
 - Input level: -20dB
 - Adjustment location:

SFR 401 (Lch)
SFR 402 (Rch)

Method: Record and Playback the 1kHz and 10kHz signals, and adjust so the output difference becomes $-0.5 \pm 0.5\text{dB}$.

AD-F360

AD-R460

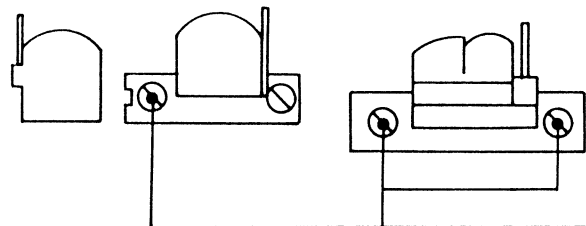

1. Head Azimuth Adjustment

- Settings:
- Test tape: TTA-317 E
 - Test point: LINE OUT
(EXCEPT Z)
DIN OUT (Z ONLY)
 - Adjustment location:

REC, PB, E head
azimuth adjustment screw
(AD-R460/R30U)
azimuth adjustment screw
(AD-F360/S15U)

3. Playback Frequency Response Adjustment

- Settings:
- Test tape: TTA-317 E
 - Test point: J 901-3 (Lch)
J 901-4 (Rch)
 - Dolby NR SW: OFF
 - Adjustment location:

SFR 303 (Lch)
SFR 304 (Rch)

Method: Playback the test tape, then adjust so that the output difference of 1kHz and 10kHz becomes $+0.5 \pm 0.5\text{dB}$

4. Bias Trap Coil Adjustment

- Settings: Adjustment location:
- L 351 (Lch)
 - L 352 (Rch)

Method: Adjust L 351, 352 for minimum leakage.

6. REC/PB Sensitivity Adjustment

- Settings:
- Test tape: TTA-119 J
 - Test point: J 901-3 (Lch)
J 901-4 (Rch)
 - Dolby NR SW: OFF
 - Adjustment location:

SFR 351 (Lch)
SFR 352 (Rch)

Method: Record and Playback a 1kHz signal and adjust so that the play output difference becomes $0 \sim 0.5\text{dB}$.

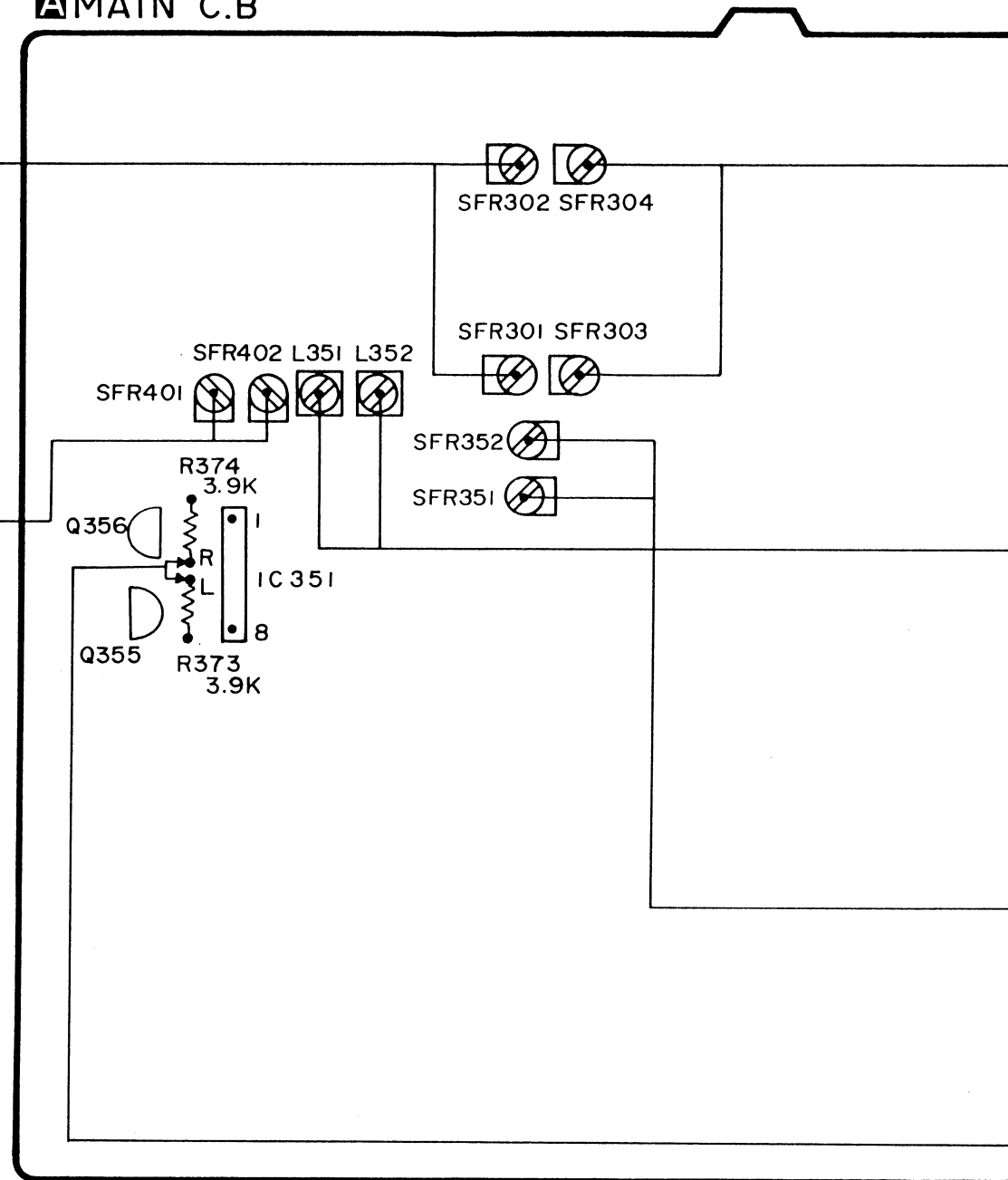

Bias Trap Coil Test Point

* J901-3(L) } on the **DIN PIN C.B**
J901-4(R) }

SCHEMATIC DIAGRAM-1 (AD-F360/S15U, AD-R460/R30U)

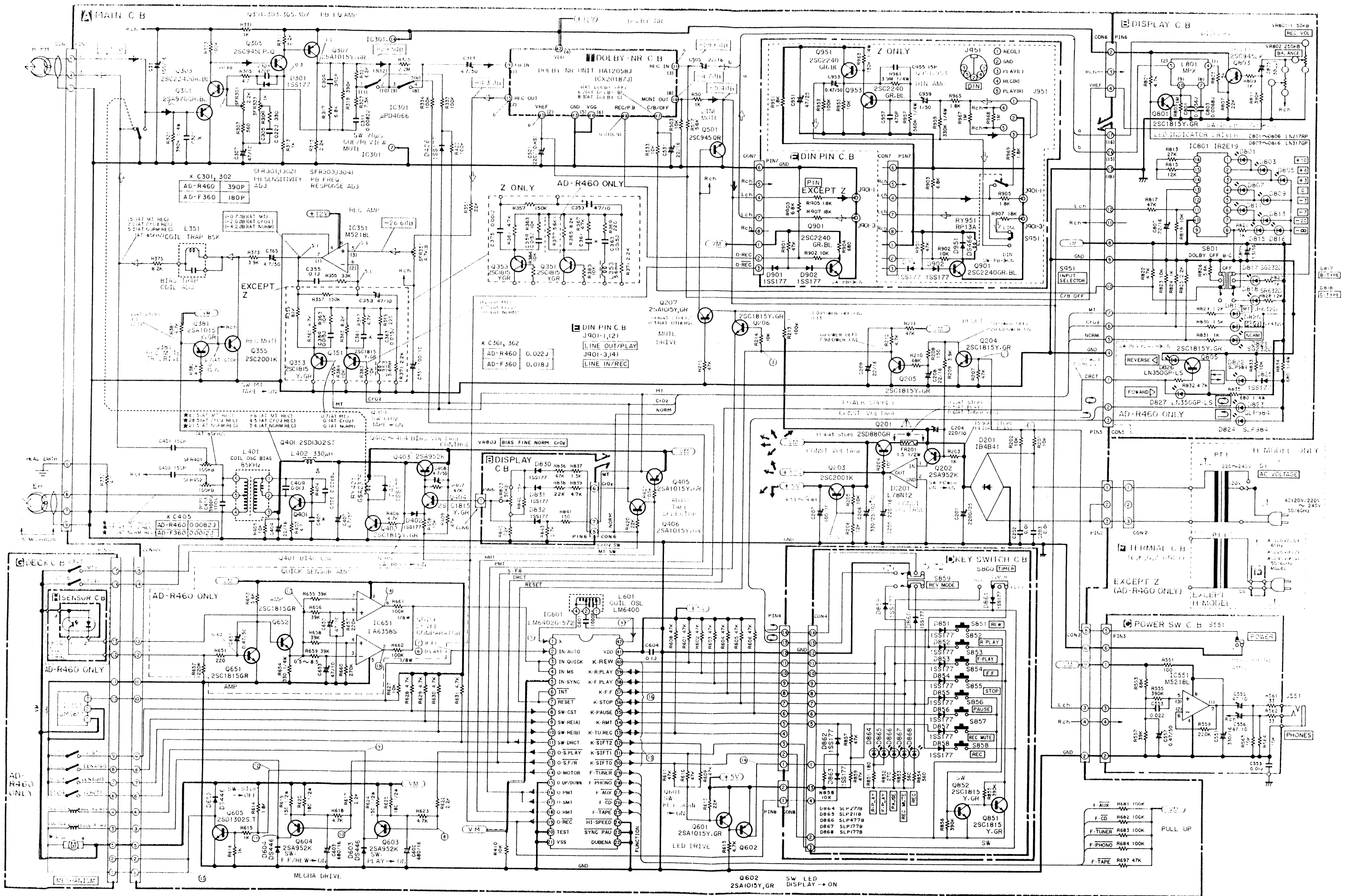

- B (+) power supply
- Signal path
- Rec path

Safety component symbol
 This symbol is given to important parts which serve to maintain the safety of the product, and which are made to conform to special safety specifications. Therefore, when replacing a component with this symbol, make absolutely sure that you use a designated part.

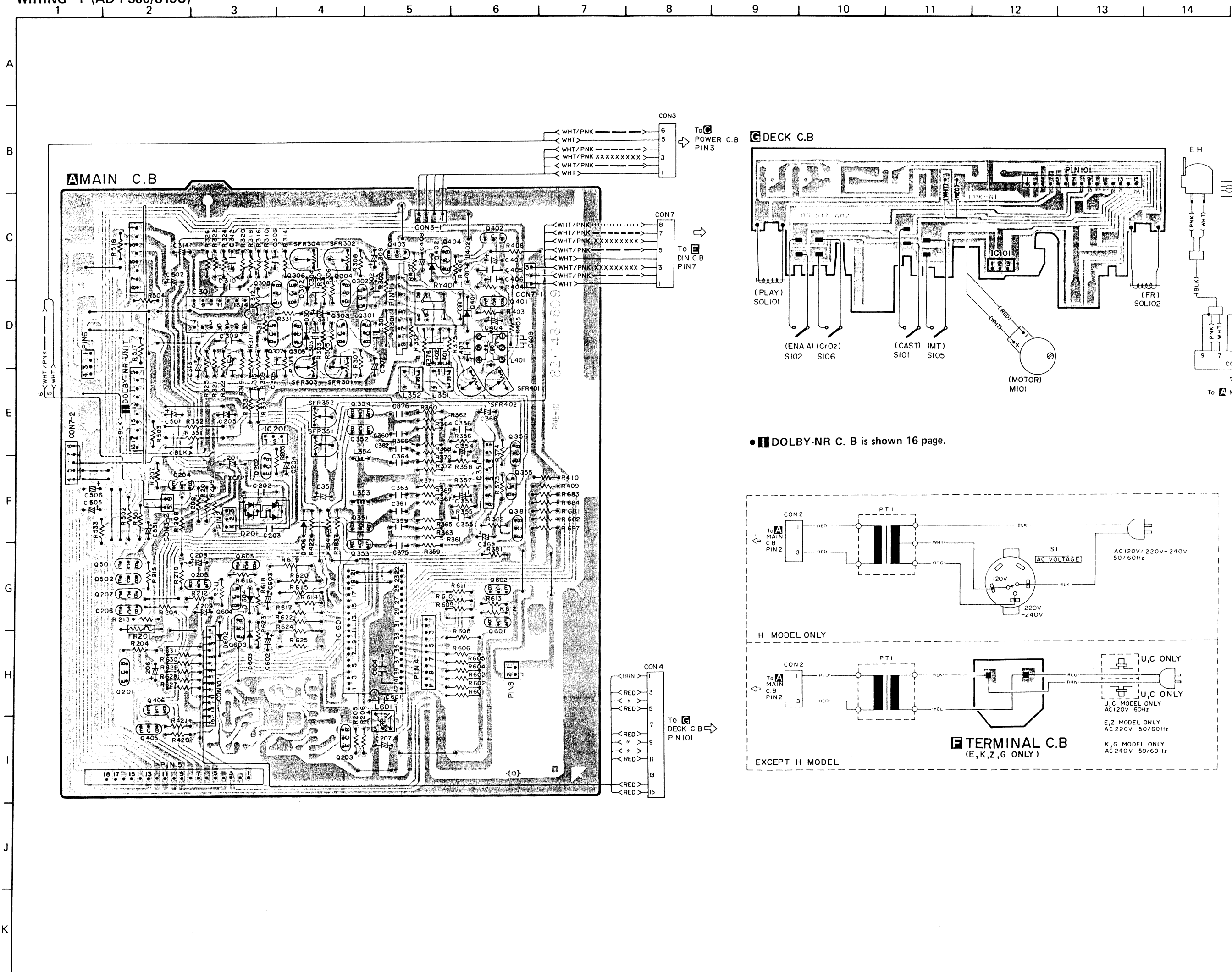

MAIN C.B

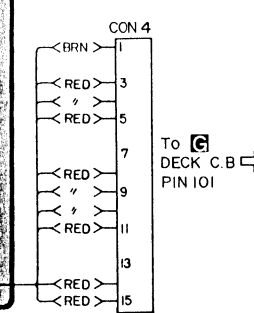
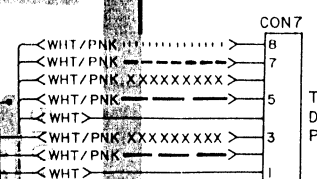
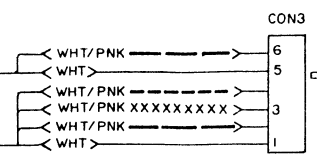

DECK C.B

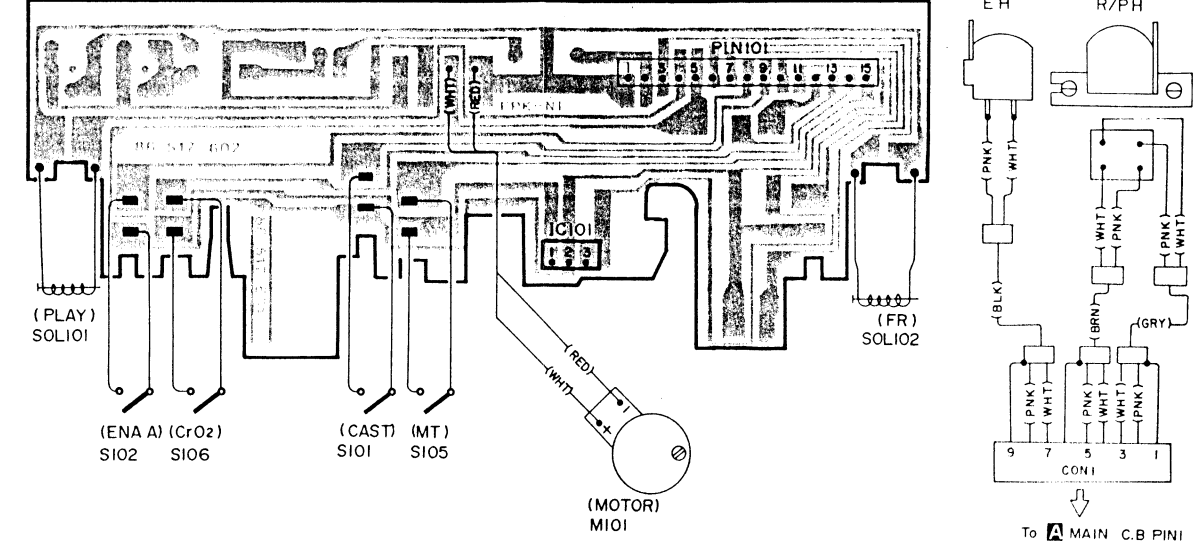

• DOLBY-NR C. B is shown 16 page.

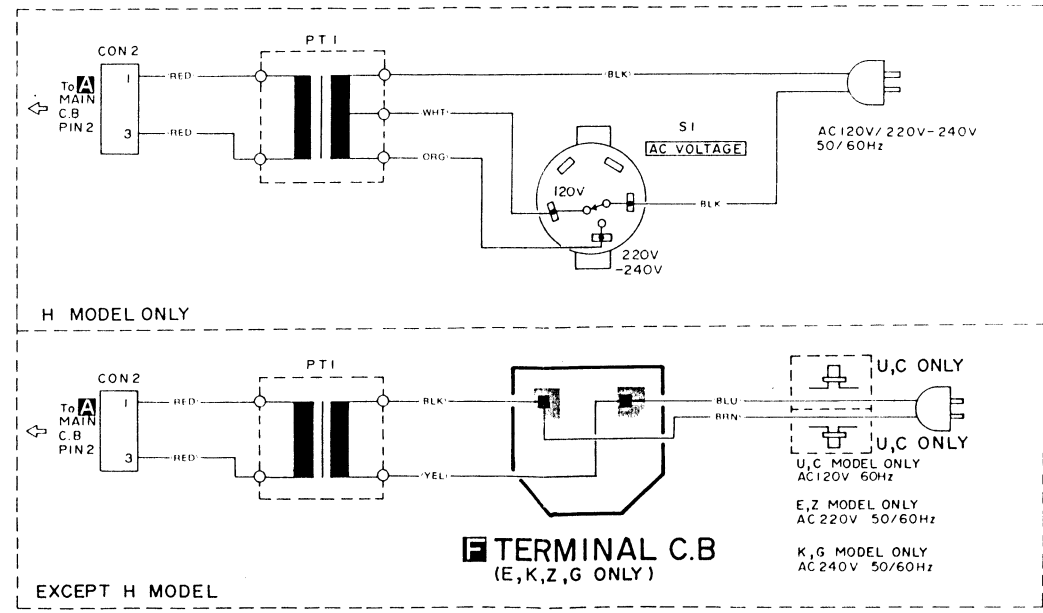

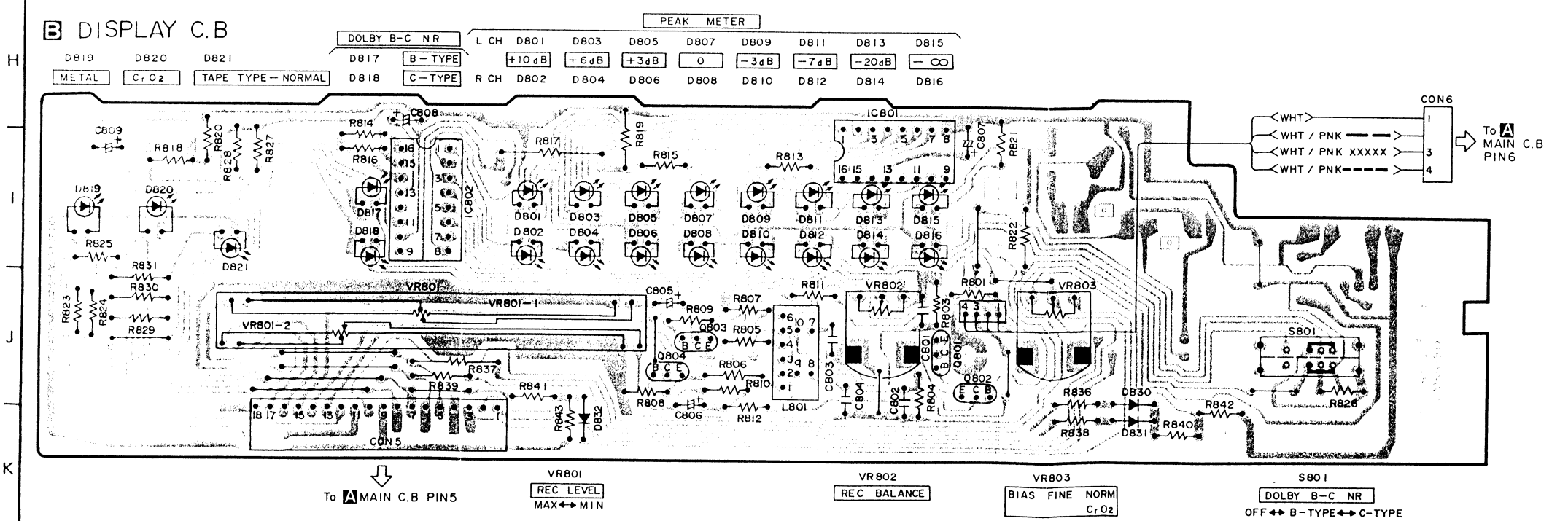
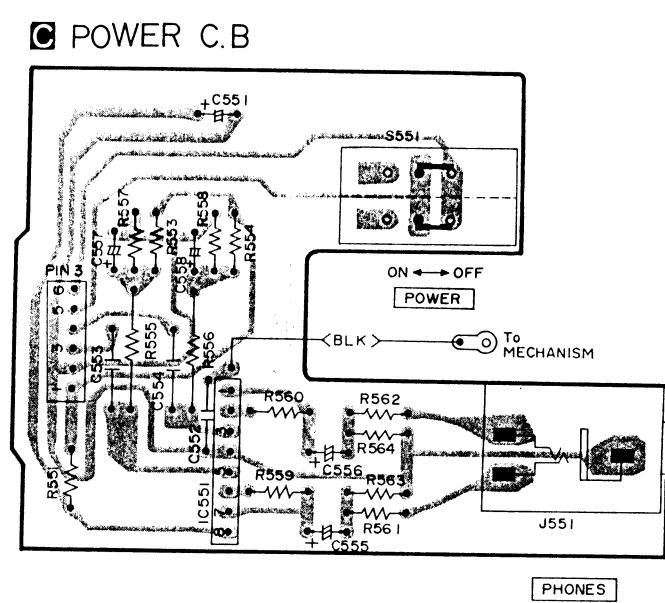
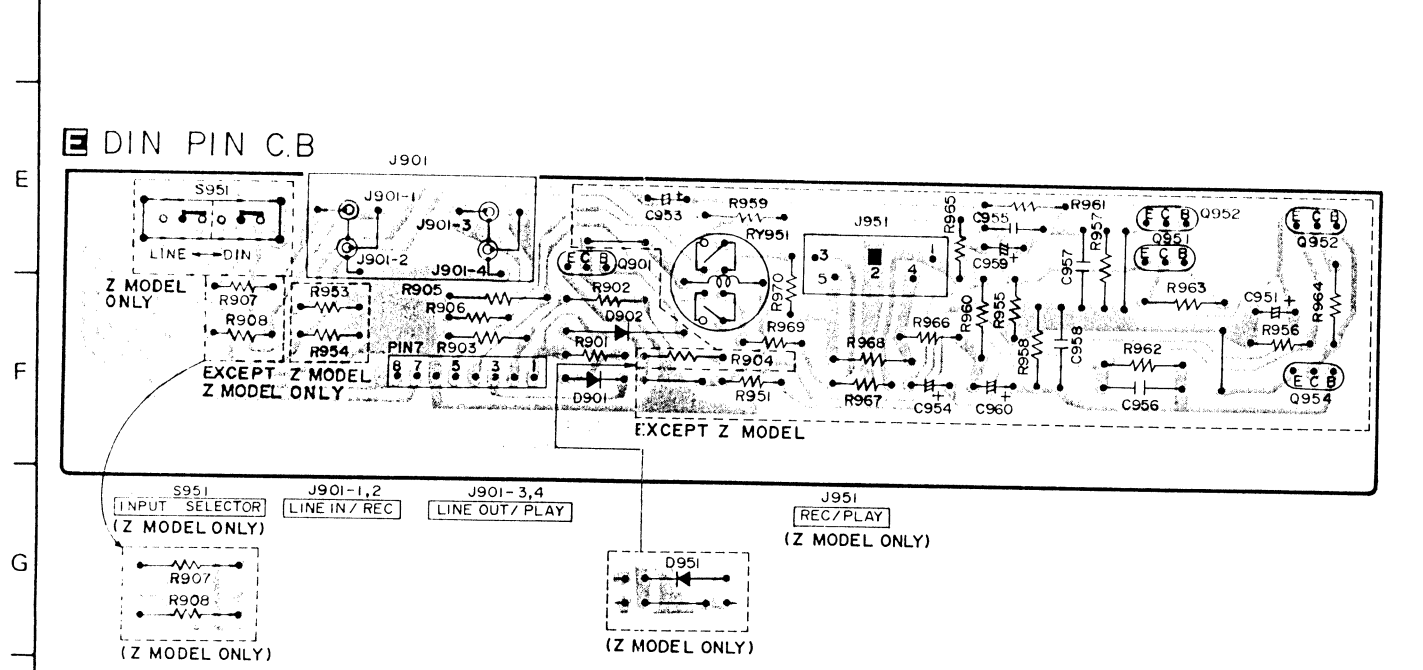
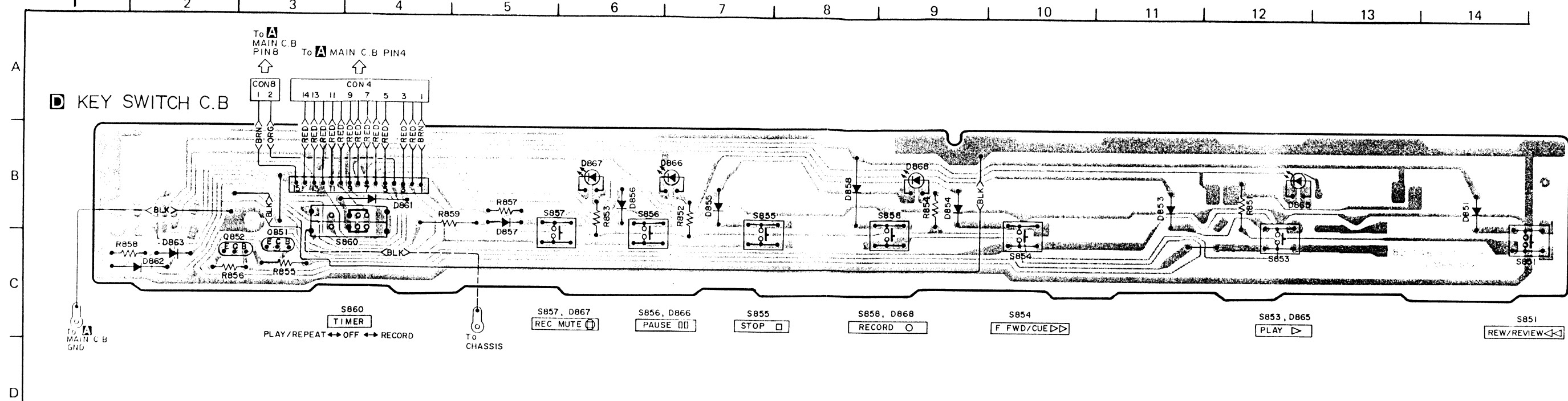

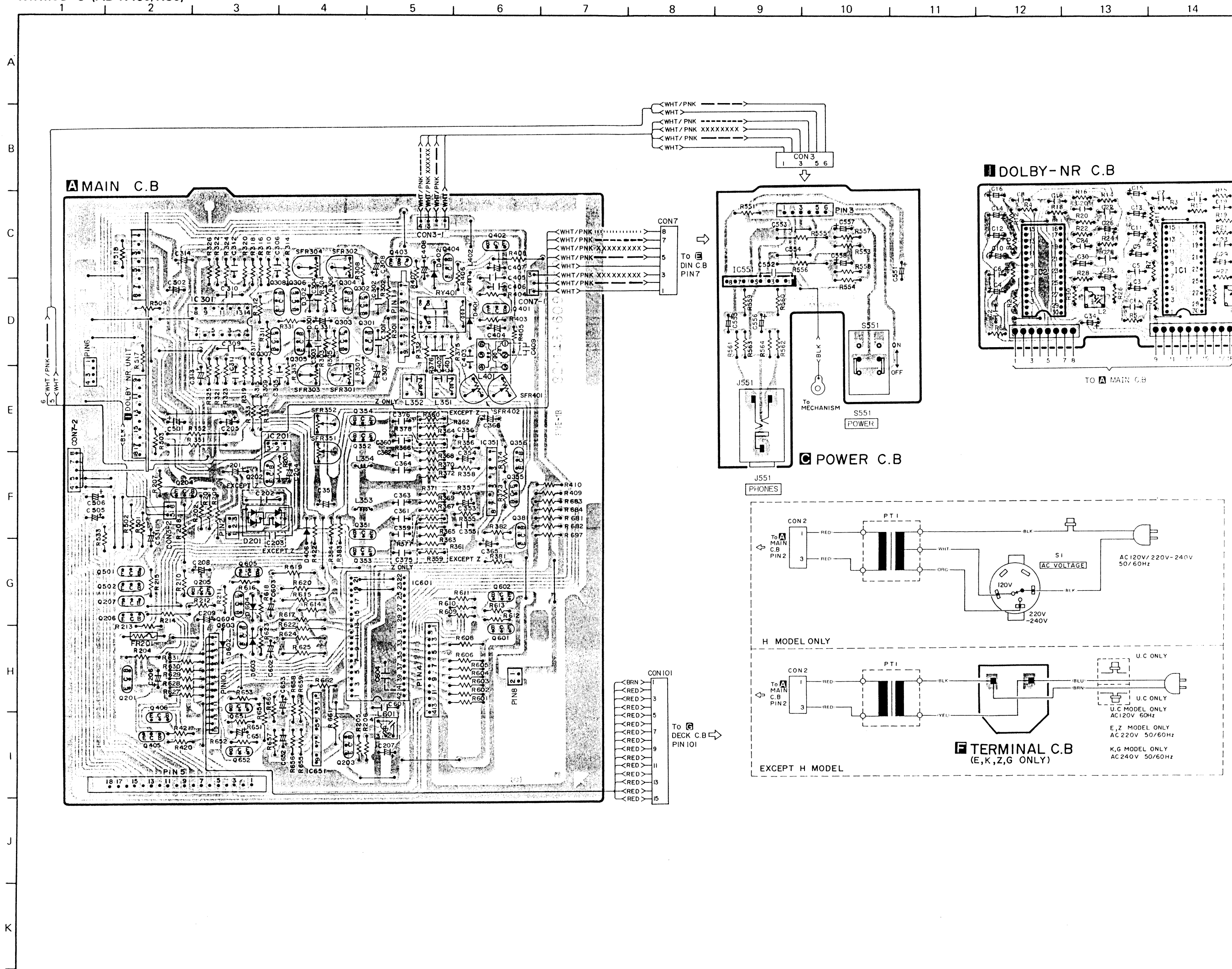

A MAIN C.B

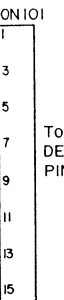
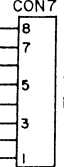
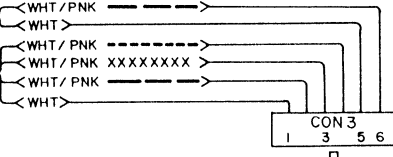

DOLBY-NR C.B

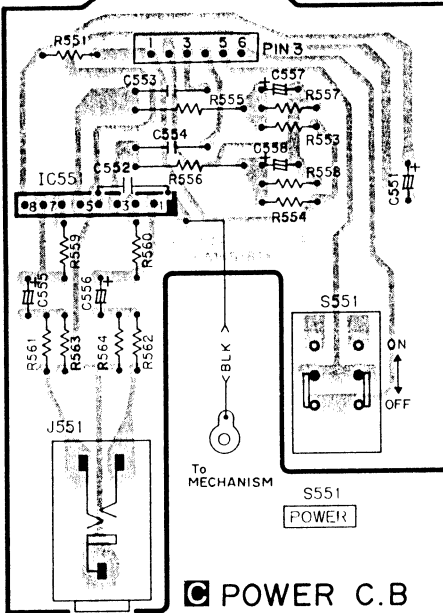
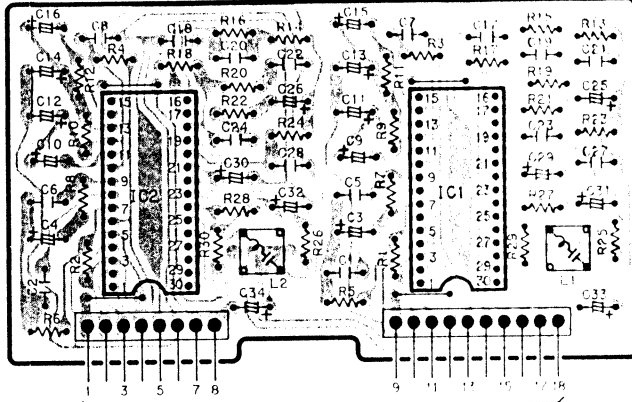

C POWER C.B

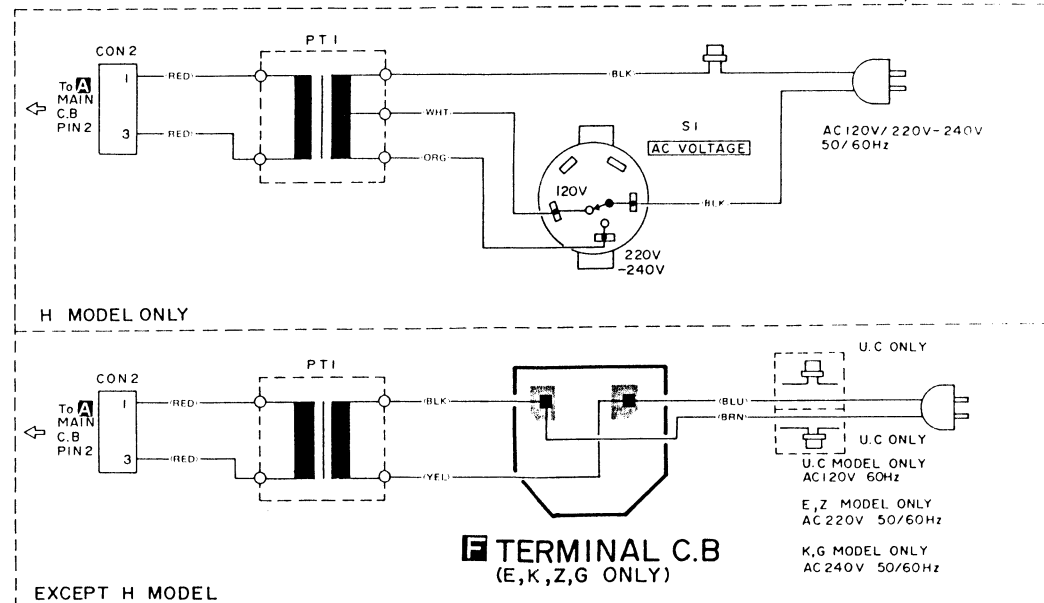

F TERMINAL C.B (E,K,Z,G ONLY)

A
B
C
D
E
F
G
H
I
J
K

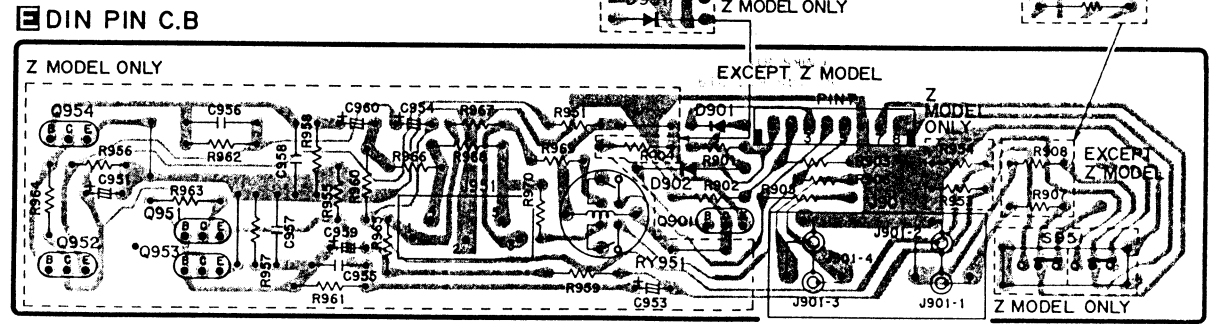
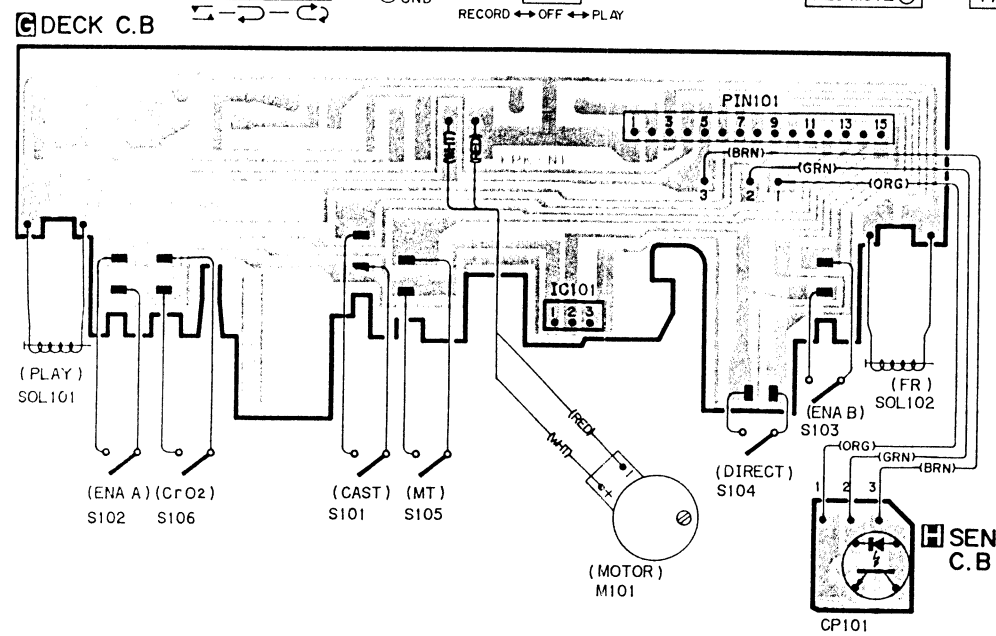
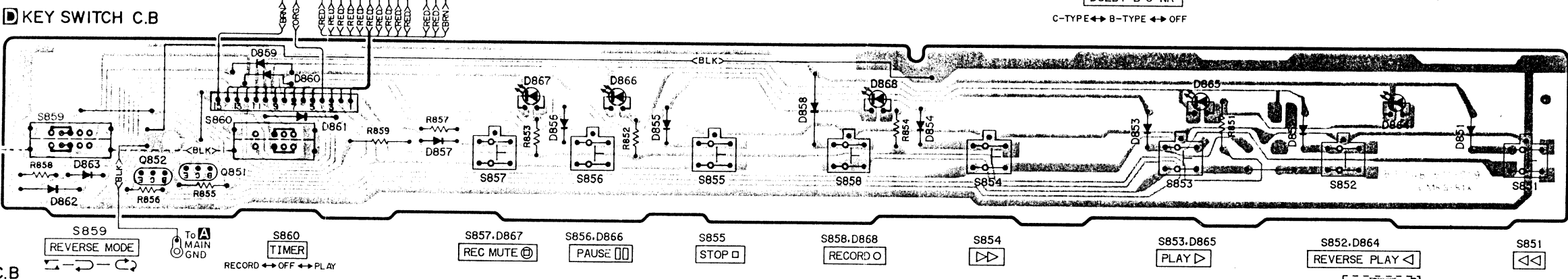
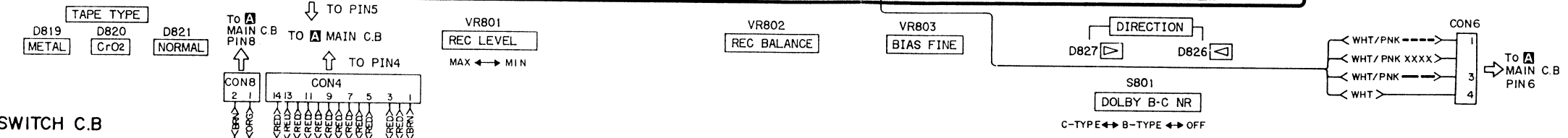
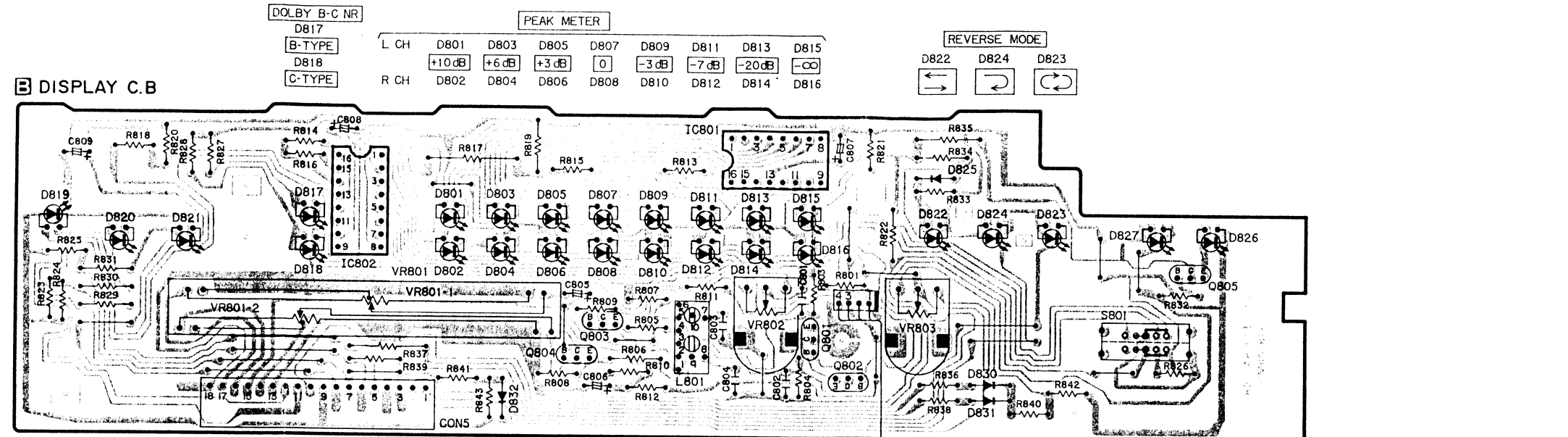

● WAVEFORMS (AD-F360/S15U, R460/R30U)

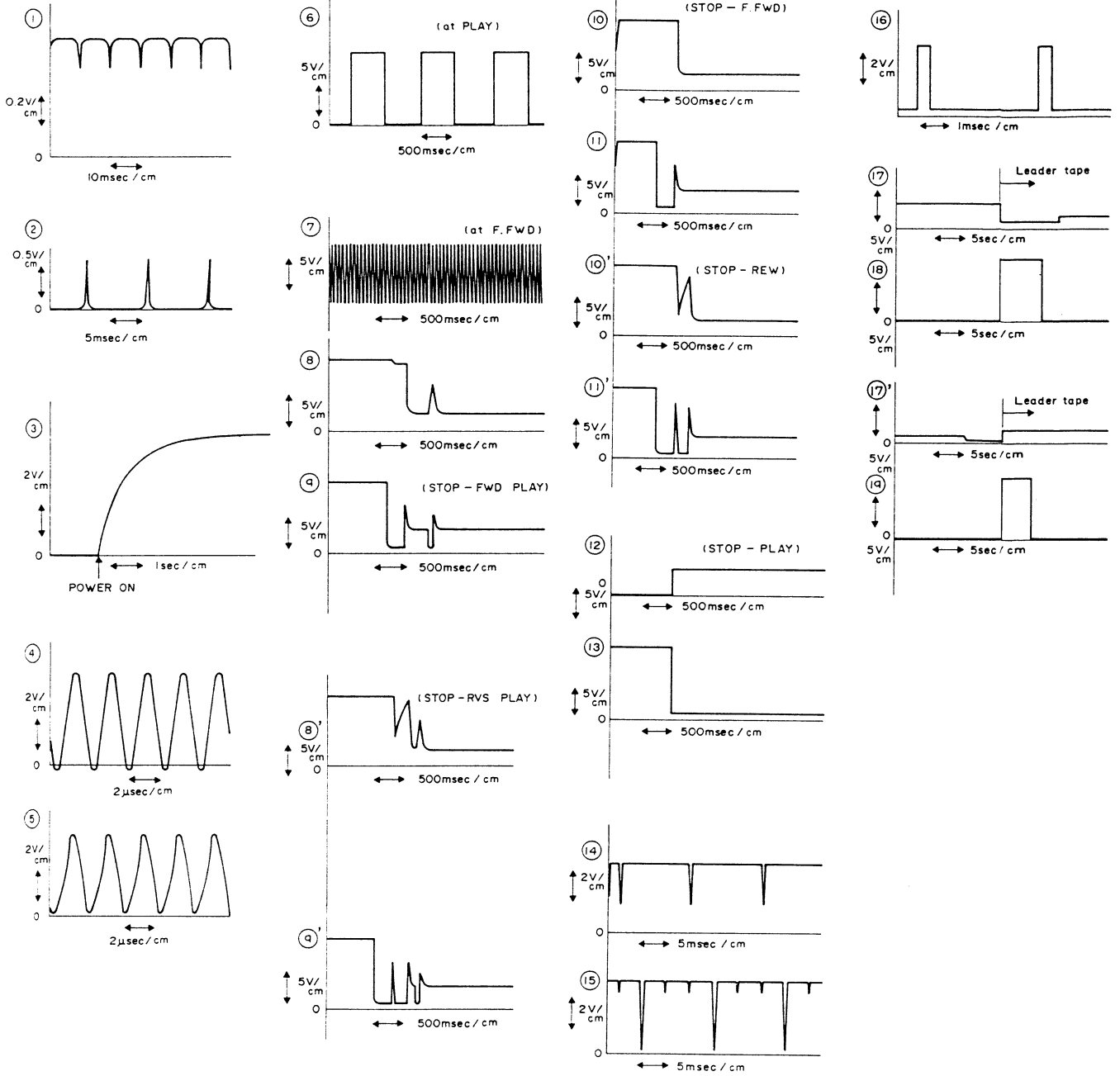

SCHEMATIC DIAGRAM-2 (AD-F360/S15U, AD-R460/R30U)

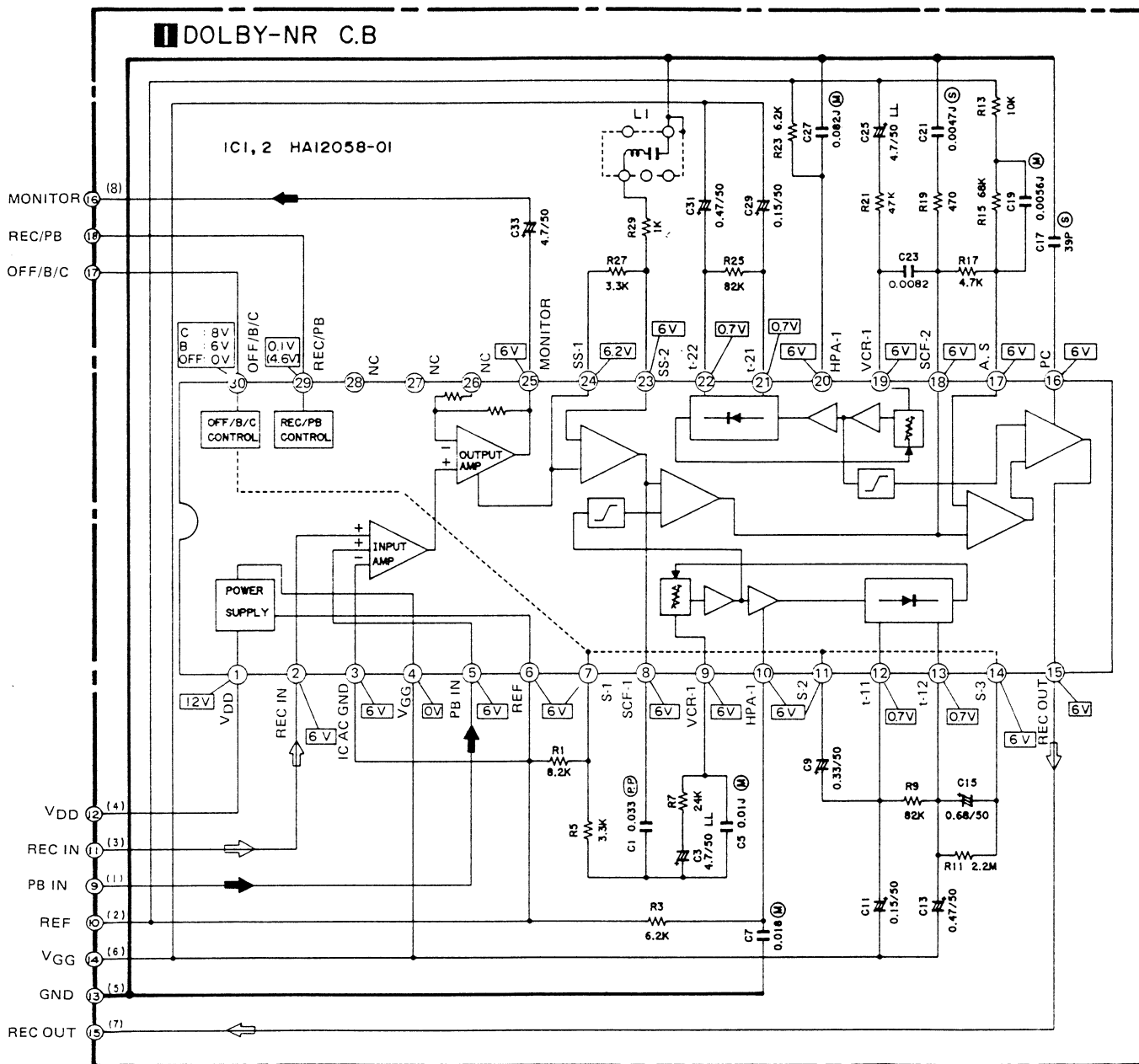

- NOTES:
- 1) → Signal path
 - ⇐ Rec path

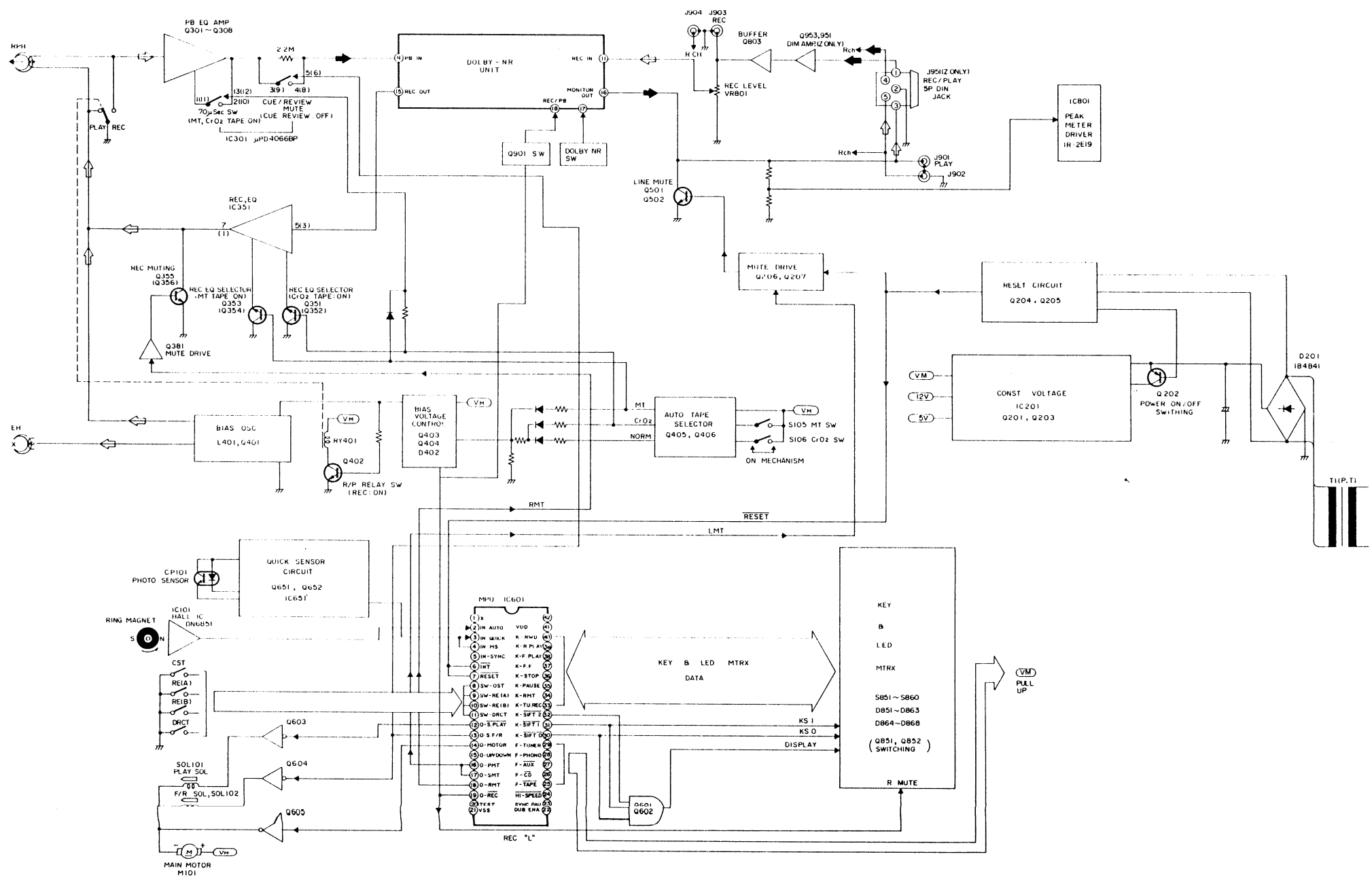

IC LM6402G-572

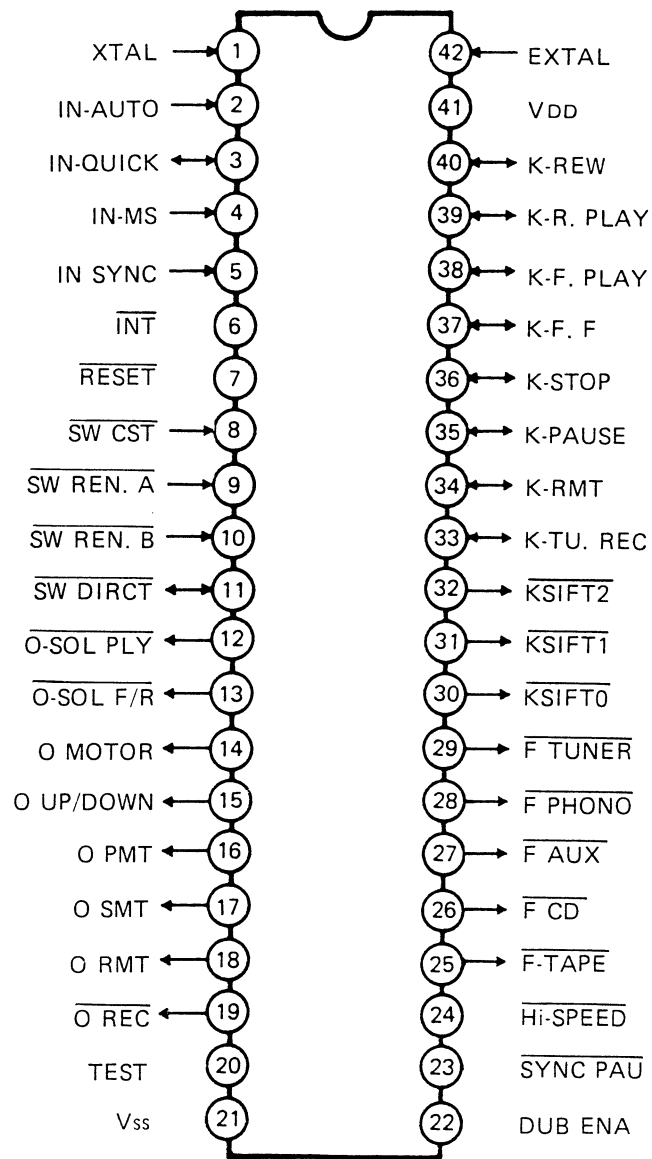

Signal flow in the direction indicated by the arrow.

IC LM6402G-572 PIN DESCRIPTION

Pin No.	Symbol	Function
1	XTAL	Input for MPU clock.
2	IN-AUTO	Input for auto-stop detection.
3	IN-QUICK	Input for tape-end sensor. (Not used AD-F360/S15)
4	IN-MS	Not used.
5	IN-SYNC	Not used.
6	$\overline{\text{INT}}$	Not used.
7	$\overline{\text{RESET}}$	Input for MPU reset. Turning the level to "L" causes the MPU to reset.
8	$\overline{\text{SW CST}}$	Input for cassette tape detection. Installing a cassette tape turns the level to "L".
9	$\overline{\text{SW REN.(A)}}$	Input for erasing protection of forward side. Turning the level to "L" enables to set up REC mode.
10	$\overline{\text{SW REN.(B)}}$	Input for erasing protection of reverse side. Turning the level to "L" enables to set up REC mode.
11	$\overline{\text{SW-DIRECT}}$	Input and output for direction detection of head. Turning the level to "L" sets the head to direction of forward side.
12	O-SOL PLY	Output for PLAY solenoid. Turning the level to "L" causes the solenoid to energize. (Refer to timing chart)
13	O-SOL F/R	Output for FF/RWD solenoid. Turning the level to "L" causes the solenoid to energize. (Refer to timing chart)
14	O-MOTOR	Output for motor on/off. Turning the level to "L" causes the motor to stop.
15	O-UP/DOWN	Not used.
16	O-PMT	Output for PLAY mute. PLAY mode only turns the level to "L".
17	O-SMT	Not used.
18	O-RMT	Output for REC mute. REC-PLAY mode only turns the level to "L".
19	O-REC	Output for REC. REC-PLAY and REC-PLAY + PAUSE modes turns the level to "L".
20	TEST	} Not used.
21	Vss	
22	DUB ENA	} Not used.
23	SYNC PAUSE	
24	HI-SPEED	
25	$\overline{\text{F-TAPE}}$	Not used.

Pin No.	Symbol	Function			
26	$\overline{\text{FCD}}$	} Not used.			
27	$\overline{\text{FAUX}}$				
28	$\overline{\text{FPHONO}}$				
29	$\overline{\text{FTUNER}}$				
30	$\overline{\text{KSIFT0}}$	Input for matrix key. Output for display assortment.			Waveform at pins
31	$\overline{\text{KSIFT1}}$				
32	$\overline{\text{KSIFT2}}$				
		Matrix key input			LED display output (Turns on by "L")
		$\overline{\text{KSIFT0}} : "L"$	$\overline{\text{KSIFT1}} : "L"$	$\overline{\text{KSIFT2}} : "L"$	$\overline{\text{KSIFT0, 1, 2}} : "H"$
33	K-TU.REC	N.C.	N.C.	One Way switch input	N.C.
34	K-RMT	REC MUTE key input	N.C.	N.C.	N.C.
35	K-PAUSE	PAUSE key input	N.C.	N.C.	N.C.
36	K-STOP	STOP key input	REV. Mode * switch input	N.C.	REC display
37	K-F.F	FF key input	REV. Mode * switch input	N.C.	REC MUTE display
38	K-F.PLAY	FWD PLAY key input	Timer REC switch input	N.C.	PAUSE display
39	K-R.PLAY	REV. PLAY * key input	Timer PLAY switch input	N.C.	FWD PLAY display
40	K-REW	REW key input	REC key input	N.C.	REV. PLAY display *
41	V_{CC}	+ 5 [V] connection pins.			
42	EXTAL	Input for MPU clock.			

※: AD-R460/R30 ONLY

NOTES:

- The voltage is the reference value measured with a tester (20 k-ohms/V DC) when there are no signals. But () is with AM reception or recording. An asterisk (*) indicates that the value was measured with a vacuum-tube voltmeter during recording.
- Resistors with no designation have a rated power of 1/8W and a tolerance of $\pm 5\%$.
- Capacitors with no designation have a dielectric strength of less than 50WV.
- The only capacitor tolerance indicated are $\pm 5\%$ (J) and $\pm 10\%$ (K).
- Ceramic capacitor symbols:
 - For temperature compensation (SL)
 - High dielectric constant system (YY)
 - High dielectric constant system (YW, YP, YZ)
 - Semiconductor ceramic
 - For temperature compensation (SH)

6) Explanation of symbols

- Mylar capacitor
- Polypropylene film capacitor
- Bi-polarized capacitor
- Low-leakage capacitor
- Fuse resistor



Safety component symbol

This symbol is given to important parts which serve to maintain the safety of the product, and which are made to conform to special safety specifications. Therefore, when replacing a component with this symbol, make absolutely sure that you use a designated part.

- This schematic diagram is subject to change without notice in the interests of improved performance.

Practical Service Figure

AD-R460/R30U

Wow & Flutter: Less than 0.075% (FWD.)
 Less than 0.085% (REV.)

Take-up torque: 30 ~ 50 g·cm
 (0.29 ~ 0.49 mN·m)

FF & rewind torque: 100 ~ 160 g·cm
 (0.98 ~ 1.57 mN·m)

Back tension: 3 ~ 5 g·cm (0.03 ~ 0.05 mN·m)
 (FWD./REV.)

PB output: EXCEPT Z
 520 ± 20 mV
 (TTA-161, LINE OUT)
 Z MODEL
 520 ± 20 mV
 (TTA-161, DIN OUT)

REC/PB output: EXCEPT Z
 0 ± 1 dB (LINE OUT)
 Z MODEL
 0 ± 1 dB (DIN OUT)

REC/PB distortion: Less than 2.5% (METAL)
 Less than 2.5% (CrO₂)
 Less than 2% (NORMAL)

Playback noise: Less than 3.0 mV
 (Unweighted) (NORMAL, DOLBY-NR OFF)
 Less than 2.5 mV
 (CrO₂, DOLBY-NR OFF)
 Less than 2.0 mV
 (METAL, DOLBY-NR C)

REC/PB SN ratio: More than 47 dB
 (Unweighted) (METAL, DOLBY-NR OFF)
 More than 45 dB
 (CrO₂, NORMAL, DOLBY-NR OFF)

Erasing ratio(125Hz): More than 55 dB

Bias frequency: 8.5 kHz

Test tape: METAL TTA-119MX
 NORMAL TTA-119J
 CrO₂ TTA-119G
 (EXCEPT Z)
 TTA-119D
 (Z MODEL)

AD-F360/S15U

Take-up torque: 40 \pm 20 g·cm
 \pm 10

FF & rewind torque: 130 ± 30 g·cm

Back tension: 4 ± 1 g·cm

PB output: EXCEPT Z
 490 ± 10 mV
 (TTA-161, LINE OUT)
 Z MODEL
 490 ± 10 mV
 (TTA-161, DIN OUT)

REC/PB output: EXCEPT Z
 0 ± 1 dB (LINE OUT)
 Z MODEL
 0 ± 1 dB (DIN OUT)

REC/PB distortion: Less than 2.5% (METAL)
 Less than 2.5% (CrO₂)
 Less than 2% (NORMAL)

Playback noise: Less than 2.5 mV
 (Unweighted) (NORMAL, DOLBY-NR OFF)
 Less than 2.5 mV
 (CrO₂, DOLBY-NR OFF)
 Less than 2.0 mV
 (METAL, DOLBY-NR C)

REC/PB SN ratio: More than 47 dB
 (Unweighted) (METAL, DOLBY-NR OFF)
 More than 45 dB
 (CrO₂, NORMAL, DOLBY-NR OFF)

Erasing ratio(125Hz): More than 55 dB

Bias frequency: 8.5 kHz

Test tape: METAL TTA-119MX
 NORMAL TTA-119J
 CrO₂ TTA-119G
 (EXCEPT Z)
 TTA-119D
 (Z MODEL)

IR2E19

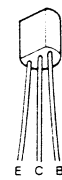
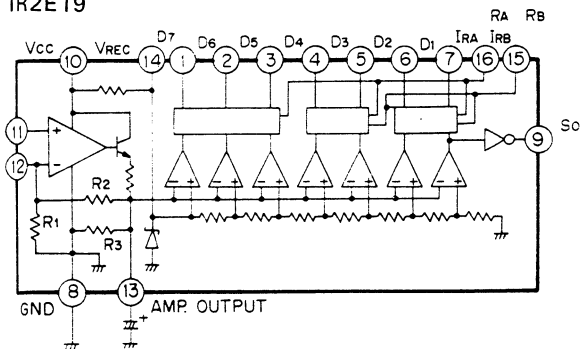

2SA952
 2SA970
 2SA1015
 2SC945
 2SC1815
 2SC2001
 2SC2240
 2SD1302

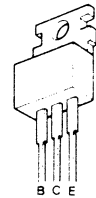

2SD880

	STOP	PLAY	F.F/ RWD	CUE/ REVIEW	PLAY PAUSE	REC	REC PAUSE
O-S-PLAY		○		○	○	○	○
O-S-F/R			○	○			
O-MOTOR	○						
O-PMT.SMT		○		○		○	○
O-RMT						○	
O-REC						○	○

○: LOW ACTIVE

EXPLODED VIEW - I (AD-F360/S15U, R460/R30U)

Ref. No.	Part No.	Description
A	87-351-096-21	VT, + 3 - 1 0
B	87-511-096-21	VFT, + 3 - 1 0
C	87-356-095-01	VT, + 3 - 8
D	87-081-511-01	VTT + 3 - 6
E	87-261-168-21	V + 4 - 5
F	87-258-169-11	U + 4 - 6
G	87-347-095-11	UT, + 3 - 8
H	87-517-094-21	VFT, + 3 - 6
I	87-081-531-01	QTT + 3 - 6
J	87-356-074-21	VT, + 2.6 - 8
K	87-067-051-01	PW1. 7 - 3.5 - 0.2 5

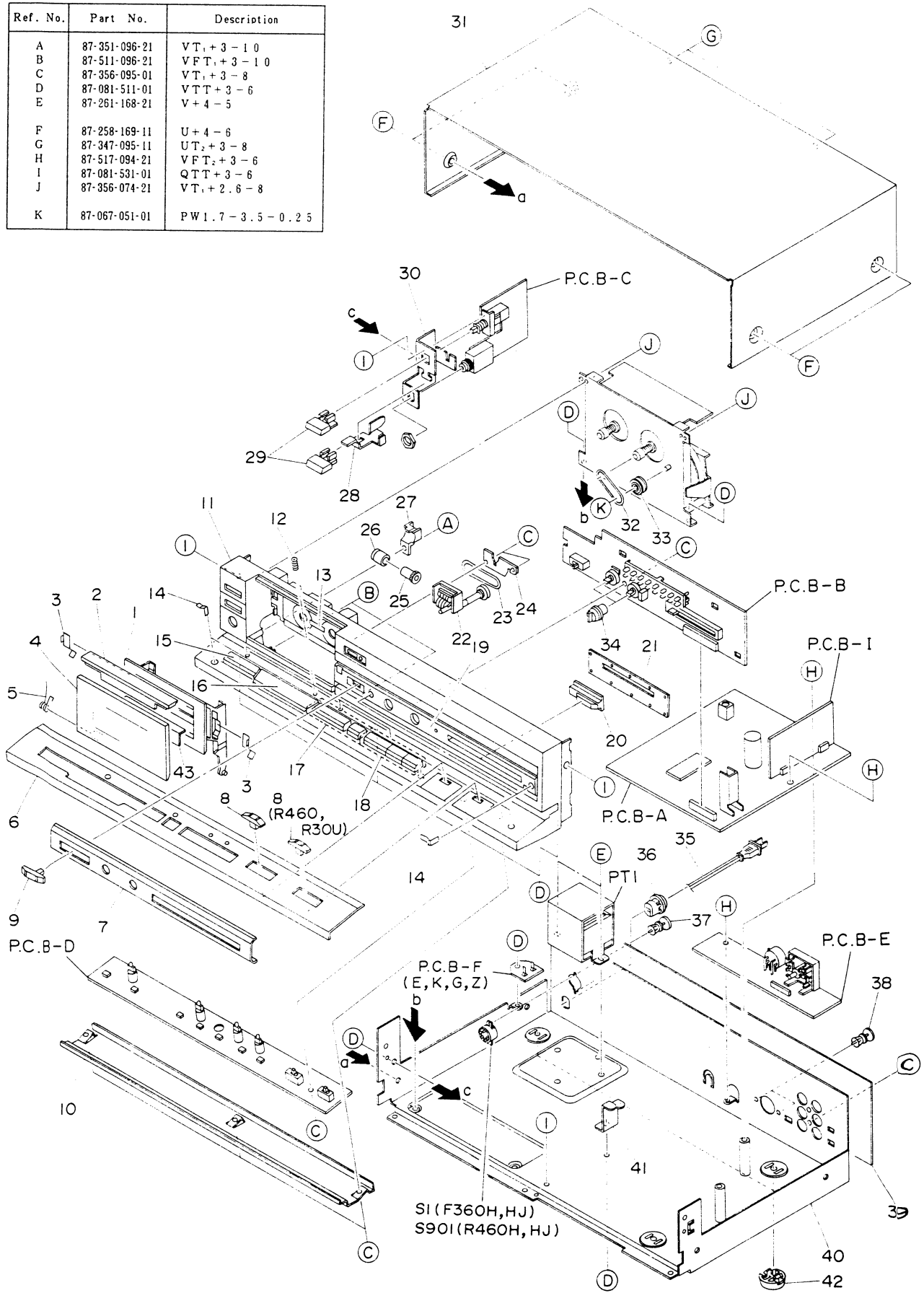

MECHANICAL PARTS LIST
(AD-F360/S15U, R460/R30U)

- ※-mark in this part list shows exclusive part.
- ★-mark means less required items availabilities may be limited.
- No availability part is marked with --- in Part No. list.

Part No. changed to	Ref. No.	Part No.	Description	Common Model	Q'ty	
	1-1	82-197-079	CASSETTE BOX	FX-90	1	
	1-2	★82-148-016	TOP PANEL, CASSETTE	※	1	
	1-3	★82-192-218	P-SPRING, CASSETTE SUPPORT	FX-30	2	
	1-4	★82-148-014	WINDOW, CASSETTE	※	1	
	1-5	★82-100-209	T-SPRING, EJECT	AD-640	1	
	1-6	★82-149-003	PANEL, CONTROL (AD-F360)	※	1	
		★82-149-015	PANEL, CONTROL (AD-S15U)	※	1	
		★82-148-003	PANEL, CONTROL (AD-R460)	※	1	
		★82-148-028	PANEL, CONTROL (AD-R30U)	※	1	
	1-7	★82-148-005	PANEL, FRONT	※	1	
	1-8	★82-148-010	SLIDE KNOB, TIMER BM	※	1	AD-F360:1
	1-9	★82-148-011	SLIDE KNOB, DOLBY BM	※	1	AD-R460:2
	1-10	---	CABINET, BOTTOM		1	
	1-11	★82-149-002	CABINET, FRONT (AD-F360)	※	1	
		★82-149-014	CABINET, FRONT (AD-S15U)	※	1	
		★82-148-002	CABINET, FRONT (AD-R460)	※	1	
		★82-148-026	CABINET, FRONT (AD-R30U)	※	1	
	1-12	★82-148-211	C-SPRING, PUSH-KEY	※	4	
	1-13	---	LABEL TAPE INDICATOR		1	
	1-14	---	TERMINAL, EARTH		5	
	1-15	★82-148-019	TOUCH-KEY, REW	※	1	
	1-16	★82-149-005	TOUCH-KEY, PLAY (AD-F360, S15U)	※	1	
		★82-148-006	TOUCH-KEY, PLAY (AD-R460, R30U)	※	1	
	1-17	★82-148-007	TOUCH-KEY, REC	※	1	
	1-18	★82-148-008	TOUCH-KEY, STOP	※	1	
	1-19	★82-149-004	WINDOW, METER (AD-F360, S15U)	※	1	
		★82-148-004	WINDOW, METER (AD-R460, R30U)	※	1	
	1-20	★82-148-009	KNOB, REC BM	※	1	
	1-21	★82-148-027	PLATE, REC VR	※	1	
	1-22	★87-040-185	COUNTER		1	
	1-23	82-446-205	RUBBER BELT, COUNTER		1	
	1-24	---	HOLDER, COUNTER		1	
	1-25	★82-534-264	GEAR, OIL-DAMP		1	
	1-26	★82-148-208	BEARING, OIL-DAMP	※	1	
	1-27	★82-683-212	HOLDER, OIL-DAMP		1	
	1-28	★82-100-206	LEVER, EJECT	AD-640	1	
	1-29	★82-188-012	KNOB, POWER	AD-F990	2	
	1-30	★82-100-205	HOLDER, POWER	AD-640	1	
	1-31	★82-148-020	STEEL CABINET	※	1	
	1-32	82-142-203	BELT, COUNTER		1	
	1-33	82-146-202	PULLEY COUNTER	FX-W60	1	
	1-34	82-148-012	KNOB, BIAS	※	2	
	1-35	★87-034-732	AC CORD (H, HJ only)		1	
		★87-034-578	AC CORD (AD-S15U, R30U) (C only)		1	
		★82-187-797	AC CORD (E, Z only)		1	
		★82-187-796	AC CORD (K only)		1	
		★82-187-795	AC CORD (G only)		1	
	1-36	★87-085-184	CORD BUSHING (H, HJ, C only) (AD-S15U, R30U)		1	
		★87-085-185	CORD BUSHING (E, K, G, Z only)		1	
	1-37	★87-085-090	NYLON RIVET #3-6.5 (H, HJ only)		2	
	1-38	★87-084-063	NYLON RIVET #3-5.5 (Z only)		2	
	1-39	---	NAME PLATE, JACK		1	
	1-40	---	AMP. CHASSIS Ass'y		1	
	1-41	---	HOLDER, PCB		1	
	1-42	★87-055-055	FOOT		1	
	1-43	★82-148-015	PLATE, CASSETTE	※	1	

EXPLODED VIEW-2

Ref. No.	Part No.	Description
A	87-251-036-21	U+2-8
B	87-351-033-21	VT,+2-4
C	87-067-218-01	VTT+2-10
D	87-081-504-01	VTT+2.6-10
E	87-067-217-01	VFT,+2-6
F	87-067-177-01	V+1.6-5.5
G	87-067-105-01	PW3.4-8-0.5

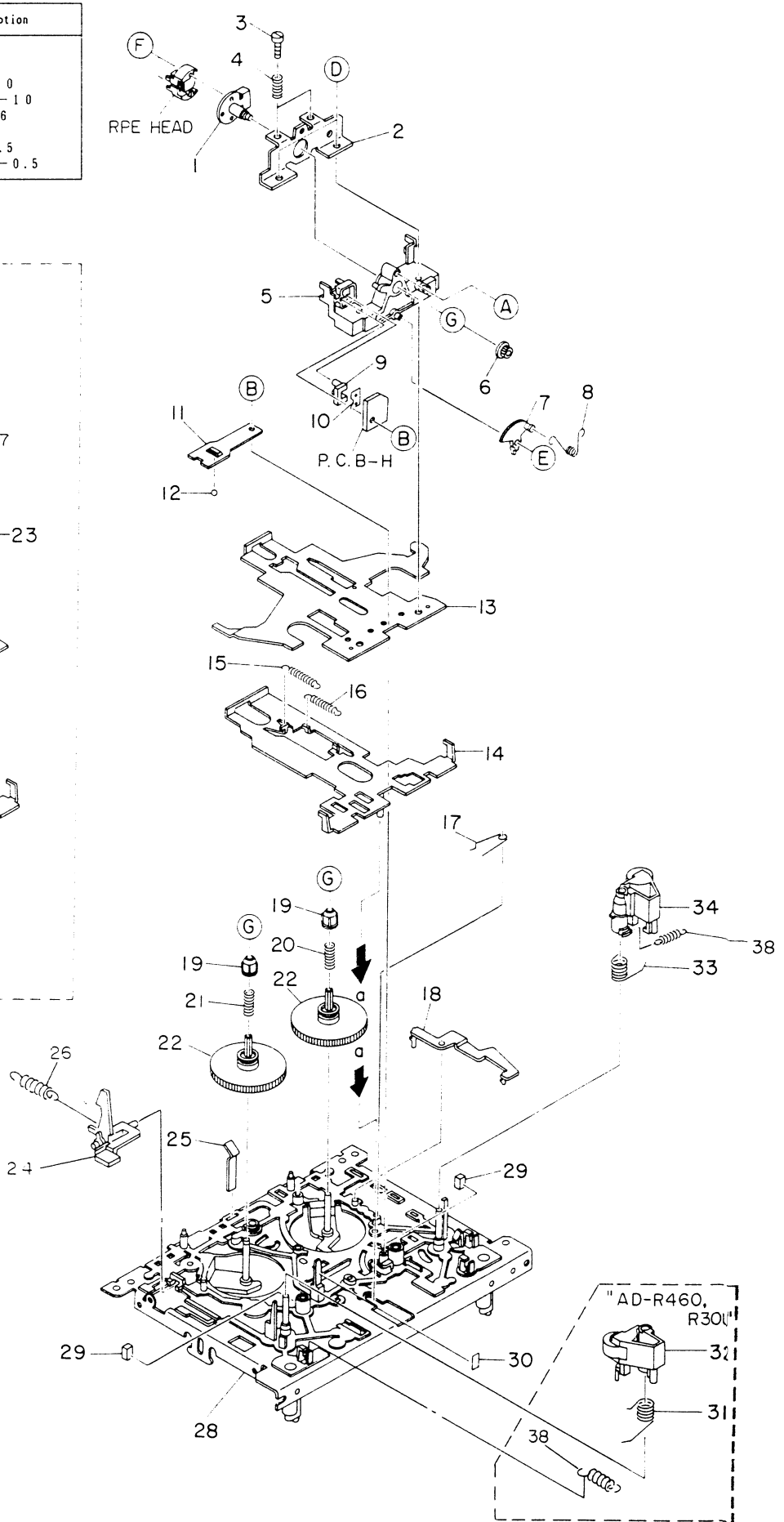
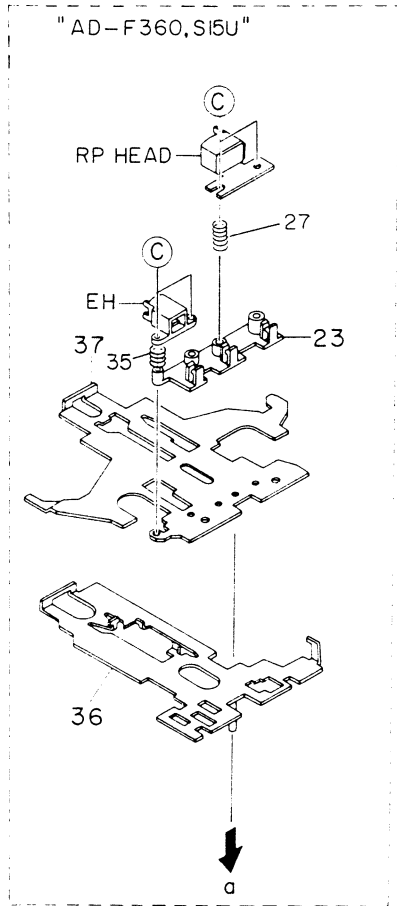

Part No. changed to	Ref. No.	Part No.	Description	Common Model	Q'ty
	2-1	86-513-267	HEAD HOUSING Ass'y (AD-R460)		1
	2-2	★86-517-268	HOLDER, AZIMUTH SCREW(AD-R460)		1
	2-3	86-517-296	AZIMUTH SCREW (AD-R460)		2
	2-4	★86-517-291	C-SPRING, AZIMUTH (AD-R460)		2
	2-5	★86-517-269	HEAD BASE Ass'y (AD-R460)		1
	2-6	86-513-299	GEAR, HEAD HOUSING (AD-R460)		1
	2-7	86-517-273	GEAR, HEAD ROLLING A (AD-R460)		1
	2-8	★86-517-282	T-SPRING, ROLLING (AD-R460)		1
	2-9	★86-517-297	SENSOR LENS (AD-R460)		1
	2-10	---	SHEET, SENSOR LENS (AD-R460)		1
	2-11	★86-517-275	P-SPRING, ACTUATING CHASSIS		1
	2-12	★87-073-008	STEEL BALL 2.5ø		1
	2-13	★86-517-305	ACTUATING CHASSIS R (AD-R460)		1
	2-14	★86-517-308	MOVEMENT REVERSE LEVER Ass'y (AD-R460)		1
	2-15	★86-517-283	E-SPRING, LEVER MOVEMENT S (AD-F360)		1
		★86-517-312	E-SPRING, LEVER MOVEMENT (AD-R460)		1
	2-16	★86-519-230	E-SPRING, ACTUATING CHASSIS (AD-F360)		1
		★86-519-370	E-SPRING, ACTUATING CHASSIS R (AD-R460)		1
	2-17	★86-517-310	T-SPRING, QUICK LEVER (AD-R460)		1
	2-18	★86-517-258	LEVER, DIRECTION (AD-R460)		1
	2-19	86-517-236	STOPPER, REEL PLATFORM		2
	2-20	★86-517-349	C-SPRING, REEL PLATFORM B (AD-R460)		1
		★86-519-234	C-SPRING, REEL PLATFORM S (AD-F360)		1
	2-21	★86-519-234	C-SPRING, REEL PLATFORM S		1
	2-22	86-517-235	REEL PLATFORM		2
	2-23	★86-519-209	HEAD BASE S (AD-F360)		1
	2-24	★86-517-256	LEVER, EJECT		1
	2-25	★86-517-276	P-SPRING, CASSETTE		1
	2-26	★86-519-241	E-SPRING, EJECT LEVER		1
	2-27	★86-519-211	C-SPRING, AZIMUTH (AD-F360)		1
	2-28	---	OUTSERT Ass'y		1
	2-29	---	CUSHION, ACTUATING CHASSIS		2
	2-30	---	SHEET, QUICK (AD-R460)		1
	2-31	★86-517-289	T-SPRING, PINCH LEVER R (AD-R460)		1
	2-32	86-517-250	PINCH LEVER R Ass'y (AD-R460)		1
	2-33	★86-517-210	T-SPRING, PINCH LEVER F (AD-F360)		1
		★86-517-277	T-SPRING, PINCH LEVER F (AD-R460)		1
	2-34	86-517-248	PINCH LEVER F Ass'y		1
	2-35	★81-505-285	C-SPRING, EH (AD-F360)		1
	2-36	★86-519-215	LEVER MOVEMENT SIGNAL Ass'y (AD-F360)		1
	2-37	★86-519-217	ACTUATING CHASSIS S (AD-F360)		1
	2-38	★86-513-340	E-SPRING, AUTO BLOCKING		3

EXPLODED VIEW-3

Ref. No.	Part No.	Description
A	87-251-072-21	U+2.6-5
B	87-353-095-21	VT ₂ +3-8
C	87-081-489-01	PW1.7-3.5-0.25
D	87-081-469-01	PW1.8-5-0.5
E	87-067-226-01	PW2.5-4.7-0.25

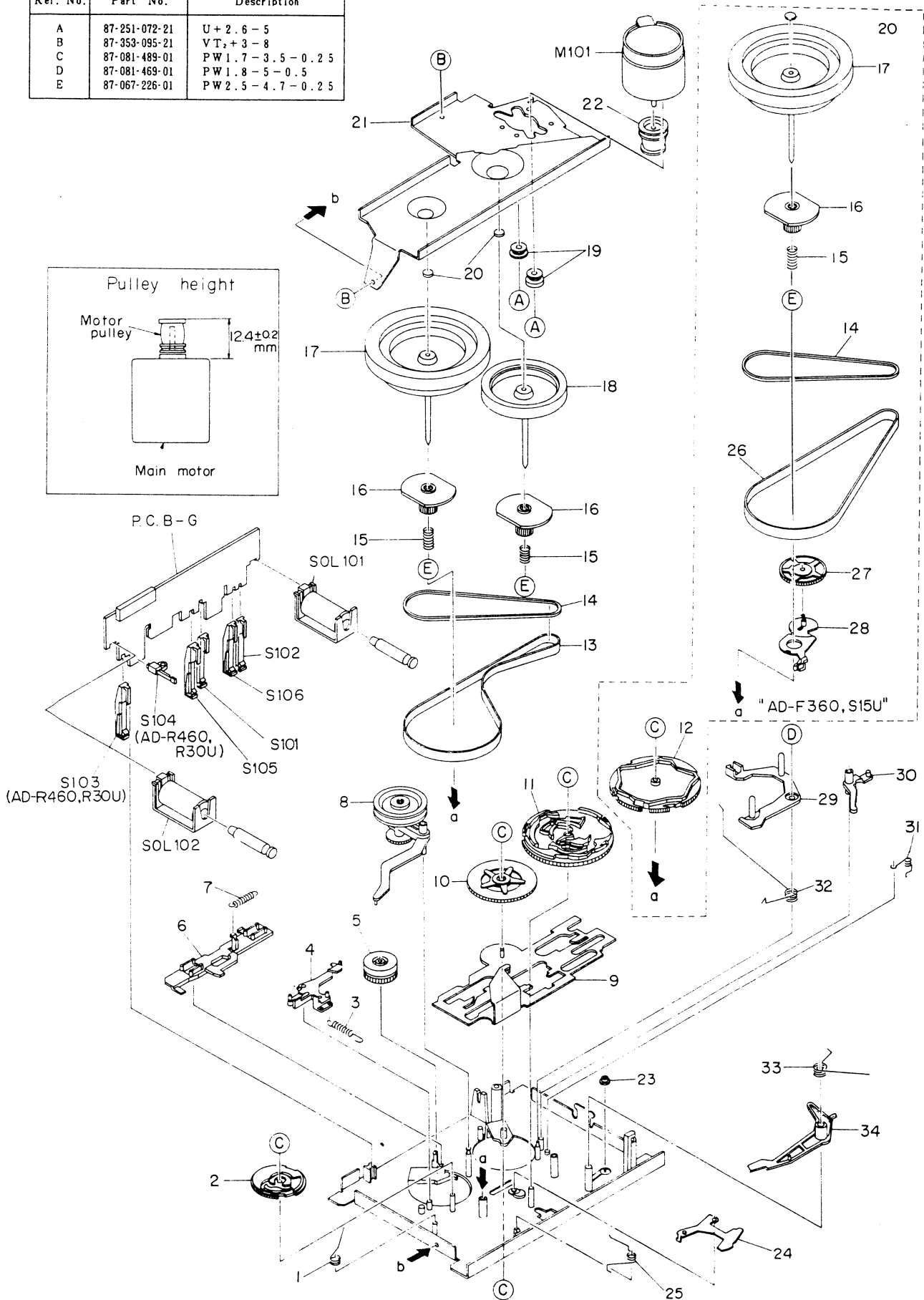

Part No. changed to	Ref. No.	Part No.	Description	Common Model	Q'ty
	3-1	★86-517-278	T-SPRING, FR CAM		1
	3-2	86-517-215	GEAR, FR CAM C		1
	3-3	★86-517-346	E-SPRING, TRIGGER LEVER FR		1
	3-4	★86-517-257	TRIGGER LEVER FR		1
	3-5	86-517-238	GEAR, FF		1
	3-6	★86-517-254	LEVER, SLIDE BRAKE		1
	3-7	★86-517-284	E-SPRING, SLIDE BRAKE		1
	3-8	86-517-239	FR PULLEY A Ass'y		1
	3-9	★86-517-263	SLIDE PLATE R Ass'y (AD-R460)		1
	3-10	86-517-225	GEAR PLAY R Ass'y (AD-R460)		1
	3-11	86-517-336	GEAR MAIN CAM R Ass'y (AD-R460)		1
	3-12	86-519-202	GEAR MAIN CAM S (AD-F360)		1
	3-13	86-517-355	MAIN BELT R-A (AD-R460)		1
	3-14	86-517-295	BELT FR		1
	3-15	★86-517-323	C-SPRING, FLYWHEEL		3
	3-16	86-517-317	GEAR, FLYWHEEL		3
	3-17	86-517-314	FLYWHEEL DC, F Ass'y		2
	3-18	86-517-318	FLYWHEEL DC, R Ass'y (AD-R460)		1
	3-19	★86-513-441	COLLAR		2
	3-20	★86-517-348	FLYWHEEL BEARING		3
	3-21	---	MOTOR HOLDER DC		1
	3-22	86-517-292	MOTOR PULLEY (AD-F360)		1
		86-517-351	MOTOR PULLEY (AD-R460)		1
	3-23	86-517-345	COLLAR SLIDE PLATE R (AD-R460)		1
	3-24	86-517-306	LEVER QUICK Ass'y (AD-R460)		1
	3-25	★86-519-222	T-SPRING, MAIN LEVER (AD-F360)		1
	3-26	86-519-232	MAIN BELT S-A (AD-F360)		1
	3-27	86-519-203	GEAR PLAY S Ass'y (AD-F360)		1
	3-28	★86-519-208	LEVER, MAIN GEAR (AD-F360)		1
	3-29	★86-517-255	LEVER, SWITCH		1
	3-30	★86-517-253	TRIGGER LEVER, PLAY-B		1
	3-31	★86-517-281	T-SPRING, SLIDE LEVER R (AD-R460)		1
	3-32	★86-517-332	T-SPRING, LEVER SWITCH		1
	3-33	★86-517-280	T-SPRING, TRIGGER LEVER PLAY		1
	3-34	★86-517-252	TRIGGER LEVER, PLAY-A		1

■ ACCESSORIES/PACKAGE LIST

AD-F360/S15

Part No. changed to	Ref. No.	Part No.	Description	Common Model	Q'ty	
	1	★82-149-907	INSTRUCTION BOOKLET	※	1	

AD-R460/R30

Part No. changed to	Ref. No.	Part No.	Description	Common Model	Q'ty	
	1	★82-148-904	INSTRUCTION BOOKLET	※	1	

AIWA Co., Ltd. Tokyo Japan