

# AIWA®

# AD-R507 AD-F410

# SERVICE MANUAL

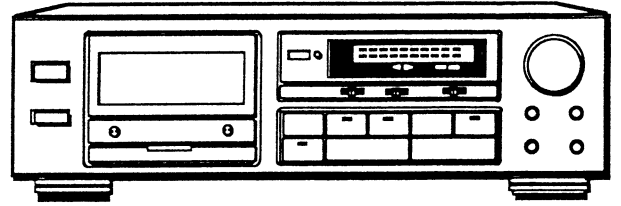

STEREO CASSETTE DECK

• BASIC TAPE MECHANISM :  $\alpha$  - 14

• TYPE. U (R507)  
H,E,K,Z (F410)

## SPECIFICATIONS

### AD-R507

<b>Type</b>	Stereo cassette tape deck
<b>Track format</b>	4 tracks, 2 channels
<b>Power supply</b>	AC 120 V, 60 Hz
<b>Power consumption</b>	12 W
<b>Frequency response</b>	METAL tape: 20–18,000 Hz CrO <sub>2</sub> tape: 20–17,000 Hz NORMAL tape: 20–16,000 Hz
<b>Signal-to-noise ratio</b>	73 dB (METAL tape DOLBY C NR ON above 5 kHz)
<b>Wow and flutter</b>	0.065% (WRMS) 0.18% (according to DIN 45500)
<b>Tape speed</b>	4.8 cm/sec. (1 <sup>7</sup> / <sub>8</sub> ips)
<b>Recording system</b>	AC bias (frequency 85 kHz)
<b>Erase system</b>	AC erase
<b>Motor</b>	DC servomotor (1)
<b>Heads</b>	Record/playback head (1) Erase head (1) (Double-gap ferite head)
<b>Inputs</b>	REC/LINE IN maximum input sensitivity: 50 mV (47 kΩ)
<b>Outputs</b>	PLAY/LINE OUT standard output level: 350 mV (0 VU); suitable load impedance: over 47 kΩ PHONES: 0.14 mW (32Ω)
<b>Dimensions</b>	430(W) × 133(H) × 269(D) mm 17 (W) × 5 <sup>1</sup> / <sub>4</sub> (H) × 10 <sup>5</sup> / <sub>8</sub> (D) inches
<b>Weight</b>	3.9 kg 8.58 lbs.

### AD-F410

<b>Type</b>	Stereo cassette tape deck
<b>Track format</b>	4 tracks, 2 channels
<b>Power supply</b>	AD-F410E, Z AC 220 V, 50 Hz AD-F410K AC 240V, 50 Hz AD-F410H AC 110–120 V/220–240 V switchable, 50/60 Hz
<b>Power consumption</b>	12 W
<b>Frequency response</b>	METAL tape: 20–20,000 Hz CrO <sub>2</sub> tape: 20–18,000 Hz NORMAL tape: 20–17,000 Hz
<b>Signal-to-noise ratio</b>	73 dB (METAL tape DOLBY C NR ON above 5 kHz)
<b>Wow and flutter</b>	0.065% (WRMS) 0.18% (according to DIN 45500)
<b>Tape speed</b>	4.8 cm/sec. (1 <sup>7</sup> / <sub>8</sub> ips)
<b>Recording system</b>	AC bias (frequency 85 kHz)
<b>Erase system</b>	AC erase
<b>Motor</b>	DC servomotor (1)
<b>Heads</b>	Record/playback head (1) (PC-OCC super DX head) Erase head (1) (Double-gap ferite head)
<b>Inputs</b>	REC/LINE IN maximum input sensitivity: 50 mV (47 kΩ) DIN max sensitivity (Z model only): 0.1 mV/kΩ (3.3 kΩ)
<b>Outputs</b>	PLAY/LINE OUT standard output level: 350 mV (0 VU); suitable load impedance: over 47 kΩ DIN standard level (Z model only): 0.3 V (0 VU) PHONES: 0.14 mW (32Ω)
<b>Dimensions</b>	430(W) × 133(H) × 269(D) mm 17 (W) × 5 <sup>1</sup> / <sub>4</sub> (H) × 10 <sup>5</sup> / <sub>8</sub> (D) inches
<b>Weight</b>	3.9 kg 8.6 lbs

• Design and specifications are subject to change without notice.

- Dolby noise reduction and HX Pro headroom extension manufactured under license from Dolby Laboratories Licensing Corporation. HX Pro originated by Bang & Olufsen.
- "DOLBY", the double-D symbol , and "HX PRO" are trademarks of Dolby Laboratories Licensing Corporation.

# ELECTRICAL MAIN PARTS LIST

REF. NO.	PART NO.	DESCRIPTION
===IC===		
	87-001-440-019	IC, BA15218N
	87-001-983-010	IC, CXA1331S
	87-001-533-010	IC, GP1U501 (REMOTE SENSOR) (R507)
	87-020-312-019	IC, HD14069UBP (R507)
	80-DS4-619-010	IC, LC6554H-4489
	87-020-758-019	IC, NJM2068SD
	87-020-680-019	IC, NJM2068S
	87-027-656-019	IC, TC4066BP
	87-027-827-019	IC, TC4069UBP (F410)

REF. NO.	PART NO.	DESCRIPTION
===TRANSISTOR===		
	89-503-735-019	FET, 2SK373GR
	89-110-155-019	TRANSISTOR, 2SA1015GR
	89-112-965-019	TRANSISTOR, 2SA1296GR
	87-026-463-019	TRANSISTOR, 2SA933S RS
	89-109-521-019	TRANSISTOR, 2SA952K
	89-213-292-019	TRANSISTOR, 2SB1329Q
	89-213-702-019	TRANSISTOR, 2SB1370E
	87-026-462-019	TRANSISTOR, 2SC1740S RS
	89-318-156-019	TRANSISTOR, 2SC1815BL
	89-318-155-019	TRANSISTOR, 2SC1815GR
	89-320-011-019	TRANSISTOR, 2SC2001K
	89-331-130-019	TRANSISTOR, 2SC3113
	87-026-214-019	TRANSISTOR, DTA114YS
	87-026-219-019	TRANSISTOR, DTA144ES
	87-026-245-019	TRANSISTOR, DTC114ES
	87-026-218-019	TRANSISTOR, DTC144ES

REF. NO.	PART NO.	DESCRIPTION
===DIODE===		
	87-001-783-019	DIODE, 1N4002-T
	87-001-559-019	DIODE, 1SS131
	87-020-465-019	DIODE, 1SS133
	87-020-123-019	DIODE, DS446-AT
	87-027-301-019	DIODE, ZENER HZ3A1
	87-002-219-010	DIODE, ZENER UTZJ11B
	87-001-912-019	DIODE, ZENER UTZJ5.1B
	87-001-913-019	DIODE, ZENER UTZJ5.6B

REF. NO.	PART NO.	DESCRIPTION
===MAIN CIRCUIT BOARD SECTION===		
C101	★87-018-122-019	CAP, CERA-SOL U 180P-50 B
C102	★87-018-122-019	CAP, CERA-SOL U 180P-50 B
C107	★87-010-404-019	CAP, ELECT 4.7-50 SME (R507)
C108	★87-010-404-019	CAP, ELECT 4.7-50 SME (R507)
C109	★87-010-404-019	CAP, ELECT 4.7-50 SME (R507)
C110	★87-010-404-019	CAP, ELECT 4.7-50 SME (R507)
C111	★87-010-979-010	CAP, ELECT 2.2-50 BP-ES (F410)
C112	★87-010-979-010	CAP, ELECT 2.2-50 BP-ES (F410)
C113	★87-018-134-019	CAP, CERA-SOL U 0.01-16 Y
C114	★87-018-134-019	CAP, CERA-SOL U 0.01-16 Y
C201	★87-018-121-019	CAP, CERA-SOL U 150P-50 B
C202	★87-018-121-019	CAP, CERA-SOL U 150P-50 B
C203	★87-018-132-019	CAP, CERA-SOL U 2200P-16 X
C204	★87-018-132-019	CAP, CERA-SOL U 2200P-16 X
C205	★87-010-404-019	CAP, ELECT 4.7-50 SME
C206	★87-010-404-019	CAP, ELECT 4.7-50 SME
C209	★87-010-544-019	CAP, ELECT 0.1-50V (F410)
C209	★87-010-545-019	CAP, ELECT 0.22-50 SME (R507)
C210	★87-010-544-019	CAP, ELECT 0.1-50V (F410)
C210	★87-010-545-019	CAP, ELECT 0.22-50 SME (R507)
C211	★87-018-134-019	CAP, CERA-SOL U 0.01-16 Y (R507)
C211	★87-018-201-019	CAP, CERA-SOL U 5600P-16 X (F410)
C212	★87-018-134-019	CAP, CERA-SOL U 0.01-16 Y (R507)
C212	★87-018-201-019	CAP, CERA-SOL U 5600P-16 X (F410)
C301	★87-018-121-019	CAP, CERA-SOL U 150P-50 B
C302	★87-018-121-019	CAP, CERA-SOL U 150P-50 B
C303	★87-018-123-019	CAP, CERA-SOL U 220P-50 B
C304	★87-018-123-019	CAP, CERA-SOL U 220P-50 B

REF. NO.	PART NO.	DESCRIPTION
C307	★87-018-126-019	CAP, CERA-SOL U 390P-50 B
C308	★87-018-126-019	CAP, CERA-SOL U 390P-50 B
C315	★87-018-131-019	CAP, CERA-SOL U 1000P-50 B
C316	★87-018-131-019	CAP, CERA-SOL U 1000P-50 B
C317	★87-010-401-019	CAP, ELECT 1-50 SME
C318	★87-010-263-019	CAP, ELECT 100-10
C319	★87-010-382-019	CAP, ELECT 22-25 SME
C320	★87-018-131-019	CAP, CERA-SOL U 1000P-50 B
C321	★87-014-081-019	CAP, PP 0.01 (R507)
C321	★87-014-212-019	CAP, PP 0.015 (F410)
C324	★87-018-201-019	CAP, CERA-SOL U 5600P-16 X
C326	★87-010-382-019	CAP, ELECT 22-25 SME
C327	★87-010-403-019	CAP, ELECT 3.3-50 SME
C401	★87-018-133-019	CAP, CERA-SOL U 4700P-16 X
C402	★87-018-133-019	CAP, CERA-SOL U 4700P-16 X
C403	★87-018-119-019	CAP, CERA-SOL U 100P-50 B
C404	★87-018-119-019	CAP, CERA-SOL U 100P-50 B
C405	★87-010-404-019	CAP, ELECT 4.7-50 SME
C406	★87-010-404-019	CAP, ELECT 4.7-50 SME
C411	★87-010-826-019	CAP, ELECT 0.56-50 VX
C412	★87-010-826-019	CAP, ELECT 0.56-50 VX
C413	★87-010-546-019	CAP, ELECT 0.33-50 SME
C414	★87-010-546-019	CAP, ELECT 0.33-50 SME
C415	★87-010-401-019	CAP, ELECT 1-50 SME
C416	★87-010-401-019	CAP, ELECT 1-50 SME
C417	★87-010-263-019	CAP, ELECT 100-10
C418	★87-010-382-019	CAP, ELECT 22-25 SME (R507)
C501	★87-010-401-019	CAP, ELECT 1-50 SME
C502	★87-010-401-019	CAP, ELECT 1-50 SME
C503	★87-010-263-019	CAP, ELECT 100-10
C504	★87-010-263-019	CAP, ELECT 100-10
C505	★87-010-263-019	CAP, ELECT 100-10
C506	★87-010-235-019	CAP, ELECT 470-16 SME (F410, Z)
C507	★87-018-149-019	CAP, CERA-SOL U 15P-50 CH (F410, Z)
C508	★87-018-149-019	CAP, CERA-SOL U 15P-50 CH (F410, Z)
C509	★87-018-127-019	CAP, CERA-SOL U 470P-50 B (F410, Z)
C510	★87-018-127-019	CAP, CERA-SOL U 470P-50 B (F410, Z)
C511	★87-010-401-019	CAP, ELECT 1-50 SME (F410, Z)
C512	★87-010-401-019	CAP, ELECT 1-50 SME (F410, Z)
C513	★87-018-127-019	CAP, CERA-SOL U 470P-50 B (F410, Z)
C514	★87-018-127-019	CAP, CERA-SOL U 470P-50 B (F410, Z)
C515	★87-010-546-019	CAP, ELECT 0.33-50 SME (F410, Z)
C516	★87-010-546-019	CAP, ELECT 0.33-50 SME (F410, Z)
C517	★87-010-546-019	CAP, ELECT 0.33-50 SME
C518	★87-010-546-019	CAP, ELECT 0.33-50 SME
C519	★87-018-134-019	CAP, CERA-SOL U 0.01-16 Y
C701	★87-010-388-019	CAP, ELECT 1000-25 SME
C702	★87-010-389-019	CAP, ELECT 2200-25V SME
C703	★87-010-382-019	CAP, ELECT 22-25 SME
C704	★87-010-235-019	CAP, ELECT 470-16 SME (R507)
C704	★87-010-381-019	CAP, ELECT 330-16 SME (F410)
C705	★87-010-221-019	CAP, ELECT 470-10
C706	★87-010-221-019	CAP, ELECT 470-10
C707	★87-010-382-019	CAP, ELECT 22-25 SME
C708	★87-010-546-019	CAP, ELECT 0.33-50 SME
C709	★87-010-404-019	CAP, ELECT 4.7-50 SME
C710	★87-018-134-019	CAP, CERA-SOL U 0.01-16 Y
C711	★87-018-100-019	CAP, CERA-SOL U 4.7P-50 SL
C712	★87-018-131-019	CAP, CERA-SOL U 1000P-50 B
C713	★87-018-205-019	CAP, CERA-SOL U 0.022-25 F (R507)
C714	★87-018-119-019	CAP, CERA-SOL U 100P-50 B
C715	★87-010-401-019	CAP, ELECT 1-50 SME
C716	★87-010-382-019	CAP, ELECT 22-25 SME
C717	★87-010-546-019	CAP, ELECT 0.33-50 SME (R507)
C718	★87-010-546-019	CAP, ELECT 0.33-50 SME (R507)
C719	★87-010-404-019	CAP, ELECT 4.7-50 SME
C720	★87-010-404-019	CAP, ELECT 4.7-50 SME
C721	★87-010-263-019	CAP, ELECT 100-10

REF. NO.	PART NO.	DESCRIPTION	REF. NO.	PART NO.	DESCRIPTION
C722	★87-010-382-019	CAP, ELECT 22-25 SME	S804	87-036-170-019	TACT SW(▶▶)
J501	87-049-868-019	JACK, PIN 4P(REC/LINE IN) (PLAY/LINE OUT)	S805	87-036-170-019	TACT SW(▶▶PAUSE)
J502	87-009-026-019	JACK, DIN 5P(DIN REC←→PLAY) (F410, Z)	S806	87-036-170-019	TACT SW(●REC/●REC MUTE)
J503	87-009-043-019	JACK, 6. 3(PHONES)	S807	87-036-170-019	TACT SW(▶STOP)
L201	★82-231-622-010	COIL, 22MH-J	S808	87-036-208-019	SLIDE SW(TIMER)
L202	★82-231-622-010	COIL, 22MH-J	S809	87-036-208-019	SLIDE SW(REVERSE MODE) (R507)
L203	★82-194-634-010	COIL, 10MMH	S810	87-036-135-019	SLIDE SW(DOLBY NR)
L204	★82-194-634-010	COIL, 10MMH	VR801	84-794-621-019	VR, 50KA(REC LEVEL)
L301	★80-DS6-618-010	COIL, HX 85K-6(F410)	VR802	84-794-622-019	VR, 200KW(REC BALANCE)
L301	★80-DS4-618-010	COIL, HX85K-4(R507)	VR803	80-DS4-616-019	VR, 10KB(BIAS FINE)
L302	★80-DS6-618-010	COIL, HX 85K-6(F410)	X801	★87-030-167-019	RESONATER, CERAMIC CST 4. 0MHZ
L302	★80-DS4-618-010	COIL, HX85K-4(R507)	===POWER CIRCUIT BOARD SECTION===		
L303	★80-DS6-617-010	COIL, OSC 85K-6(F410)	△PT901	80-DS4-613-019	POWER TRANSFORMER E (F410, E, Z)
L303	★80-DS4-617-010	COIL, OSC 84K-4(R507)	△PT901	80-DS4-611-019	POWER TRANSFORMER H (F410, H)
L401	★80-DS4-620-010	FILTER, DOLBY 85K	△PT901	80-DS4-614-019	POWER TRANSFORMER K (F410, K)
L402	★80-DS4-620-010	FILTER, DOLBY 85K	△PT901	80-DS4-612-019	POWER TRANSFORMER U, C(R507, U)
S501	87-031-752-019	SLIDE SW(INPUT SELECTOR) (F410, Z)	△S901	87-031-780-019	SLIDE SW(AC VOLTAGE) (F410, H)
SFR101	★87-024-168-019	SFR, 1K	===POWER SW CIRCUIT BOARD SECTION===		
SFR102	★87-024-168-019	SFR, 1K	△C901	87-019-113-019	CAP, FILM 0. 0022E
SFR201	★87-024-172-019	SFR, 10K	△S902	87-036-184-019	PUSH SW(POWER)
SFR202	★87-024-172-019	SFR, 10K	===DECK CIRCUIT BOARD SECTION===		
SFR301	★87-024-176-019	SFR, 100K(R507)	M1	87-045-296-019	MOTOR, EG-530 AD, 2B(R507)
SFR301	★87-024-177-019	SFR, 220K(F410)	M1	87-045-312-019	MOTOR, MM1652LK(F410)
SFR302	★87-024-176-019	SFR, 100K(R507)	S1	87-036-109-010	PUSH SW(CST)
SFR302	★87-024-177-019	SFR, 220K(F410)	S2	87-036-110-010	PUSH SW(CrO2)
===FRONT CIRCUIT BOARD SECTION===			S3	87-036-110-010	PUSH SW(RE-A)
C801	★87-010-235-019	CAP, ELECT 470-16 SME	S4	87-036-109-010	PUSH SW(RE-B) (R507)
C802	★87-018-205-019	CAP, CERA-SOL U 0. 022-25 F	S5	87-036-109-010	PUSH SW(MT)
C803	★87-010-235-019	CAP, ELECT 470-16 SME	S6	87-036-109-010	PUSH SW(DIR) (R507)
C804	★87-018-205-019	CAP, CERA-SOL U 0. 022-25 F	SOL1	86-535-611-210	SOLENOID, X-3 PL(PLAY)
C805	★87-015-682-019	CAP, ELECT 22-16 7L(R507)	SOL2	86-535-612-210	SOLENOID, X-3 FR(F/R)
C806	★87-015-696-019	CAP, ELECT 2. 2-50 7L(R507)	===SENSOR CIRCUIT BOARD SECTION(R507 ONLY)===		
C807	★87-010-382-019	CAP, ELECT 22-25 SME	CP1	87-001-367-019	PHOTO SENSOR SP1-315-CD
C808	★87-018-131-019	CAP, CERA-SOL U 1000P-50 B	===RELAY CIRCUIT BOARD SECTION(R507 ONLY)===		
LED801	82-238-621-019	LED, SLB-25MG 70F120(- ∞)	===MISCELLANEOUS===		
LED802	82-238-621-019	LED, SLB-25MG 70F120(- ∞)	△	87-034-749-019	AC CORD ⟨H⟩ W/PLUG(F410, H)
LED803	82-238-621-019	LED, SLB-25MG 70F120(-20)	△	82-187-797-019	AC CORD ⟨E⟩ (F410, E, Z)
LED804	82-238-621-019	LED, SLB-25MG 70F120(-20)	△	87-034-583-019	AC CORD ASSY U (R507, U)
LED805	82-238-621-019	LED, SLB-25MG 70F120(-10)	△	82-187-796-019	AC CORD ⟨BS⟩ (F410, K)
LED806	82-238-621-019	LED, SLB-25MG 70F120(-10)	△	87-085-185-010	BUSHING, AC CORD E (F410, E, Z)
LED807	82-238-621-019	LED, SLB-25MG 70F120(-5)	△	87-085-184-010	BUSHING, AC CORD D (F410, H, R507, U)
LED808	82-238-621-019	LED, SLB-25MG 70F120(-5)	△	87-085-189-010	BUSHING, CORD U (F410, K)
LED809	82-238-621-019	LED, SLB-25MG 70F120(0)	C1	★87-010-381-019	CAP, ELECT 330-16V SME
LED810	82-238-621-019	LED, SLB-25MG 70F120(0)	EH	★87-046-196-019	E HEAD(F410)
LED811	82-238-622-019	LED, SLB-25VR 70F120(□□ 3)	RPEH	87-046-350-019	R. P. E HEAD(R507)
LED812	82-238-622-019	LED, SLB-25VR 70F120(□□ 3)	PH	87-046-343-019	R. P HEAD(F410)
LED813	82-238-622-019	LED, SLB-25VR 70F120(6)			
LED814	82-238-622-019	LED, SLB-25VR 70F120(6)			
LED815	82-238-622-019	LED, SLB-25VR 70F120(10)			
LED816	82-238-622-019	LED, SLB-25VR 70F120(10)			
LED817	80-DW1-631-019	LED, SLB55 MG70F120(DOLBY NR B)			
LED818	80-DW1-632-019	LED, SLB55 VR70F120(DOLBY NR C)			
LED819	80-DW1-631-019	LED, SLB55 MG70F120(◀) (R507)			
LED820	80-DW1-631-019	LED, SLB55 MG70F120(▶) (R507)			
LED821	82-234-606-019	LED, SLZ381C50 G L105(◀REV) (R507)			
LED822	82-234-606-019	LED, SLZ381C50 G L105(FWD▶) (R507) (▶PLAY) (F410)			
LED823	82-234-620-019	LED, SLZ981C50 R L105 (●REC/●REC MUTE)			
LED824	82-234-607-019	LED, SLZ481C50 Y L105(▶▶PAUSE)			
R877	87-025-468-019	RES, NF 1. 5 1/4W			
S801	87-036-170-019	TACT SW(◀MS)			
S802	87-036-170-019	TACT SW(◀REV) (R507)			
S803	87-036-170-019	TACT SW(FWD▶) (R507) (▶PLAY) (F410)			

BLOCK DIAGRAM

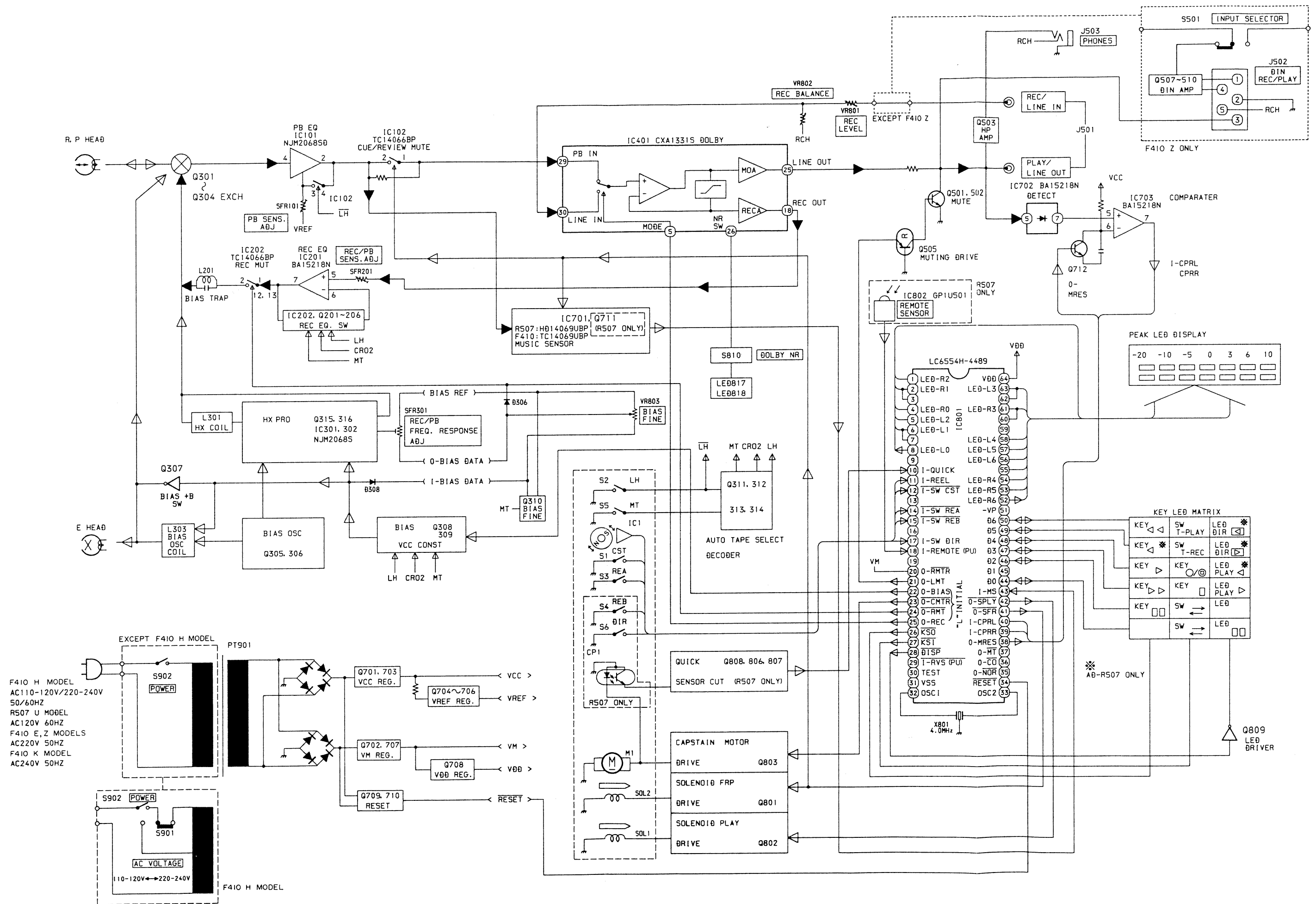

IC BLOCK DIAGRAM

IC,CXA1331S

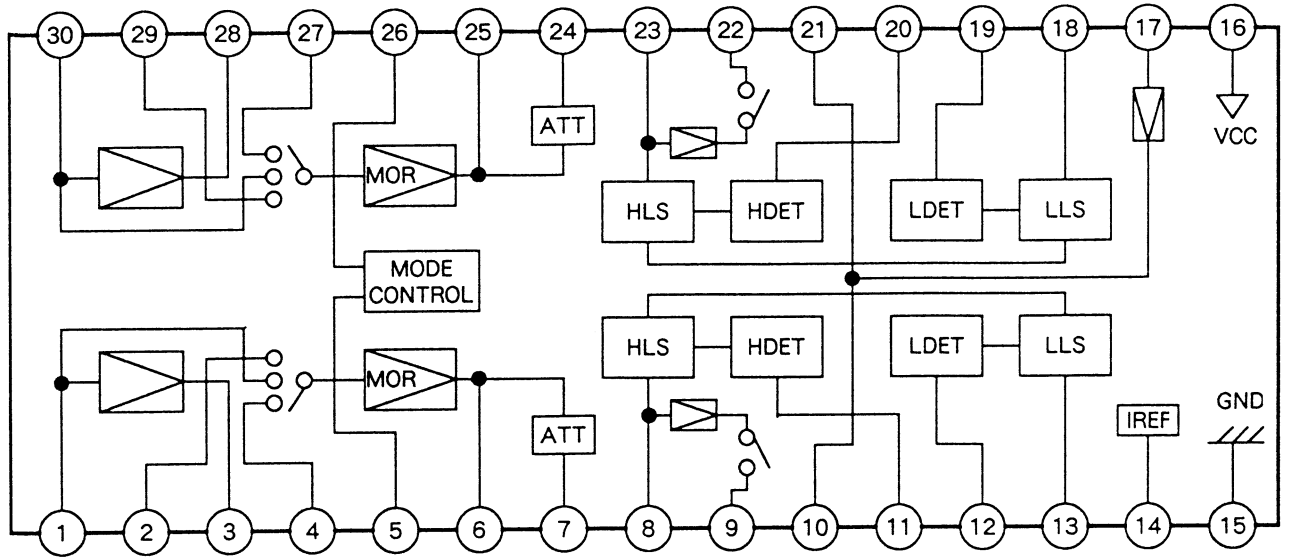

E C B

- 2SA1015
- 2SA1296
- 2SA952
- 2SC1815
- 2SC2001

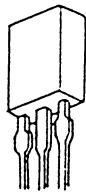

B C E

- 2SB1329

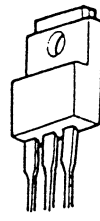

B C E

- 2SB1370
- 2SC3113



B C E

- 2SA933
- 2SC1740
- DTA114
- DTA144
- DTC114
- DTC144



S G D

- 2SK373

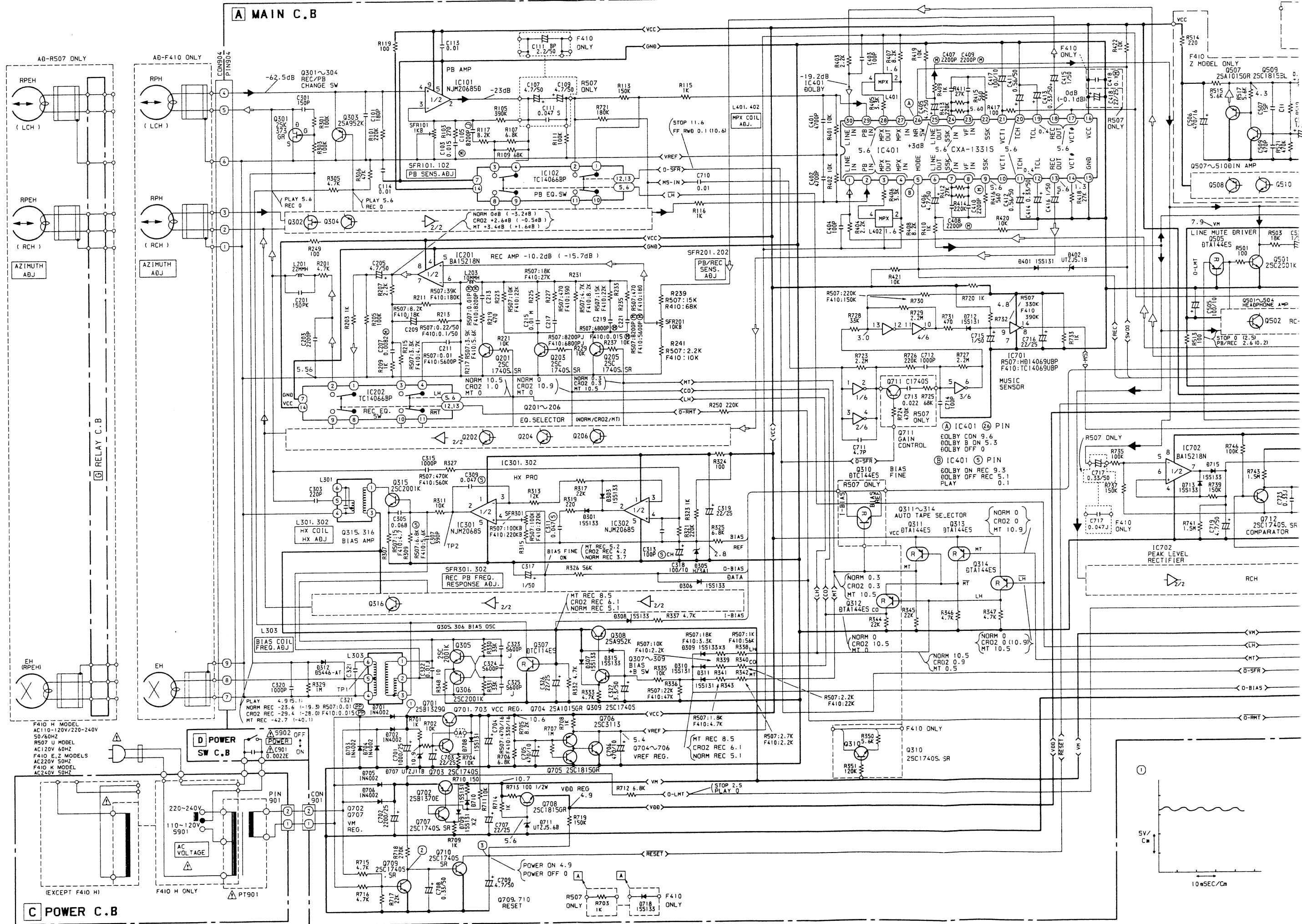

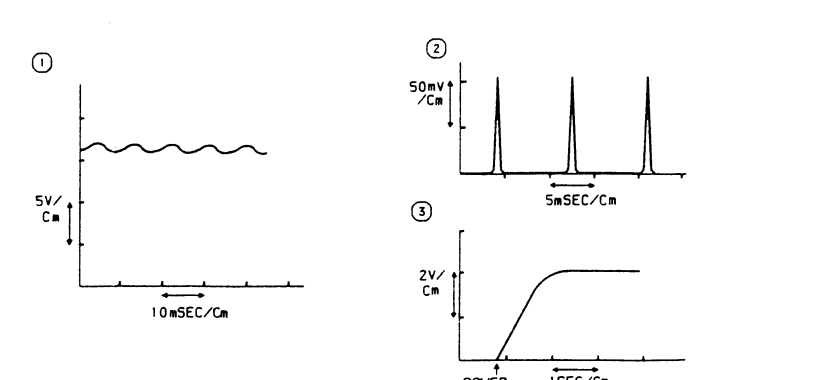
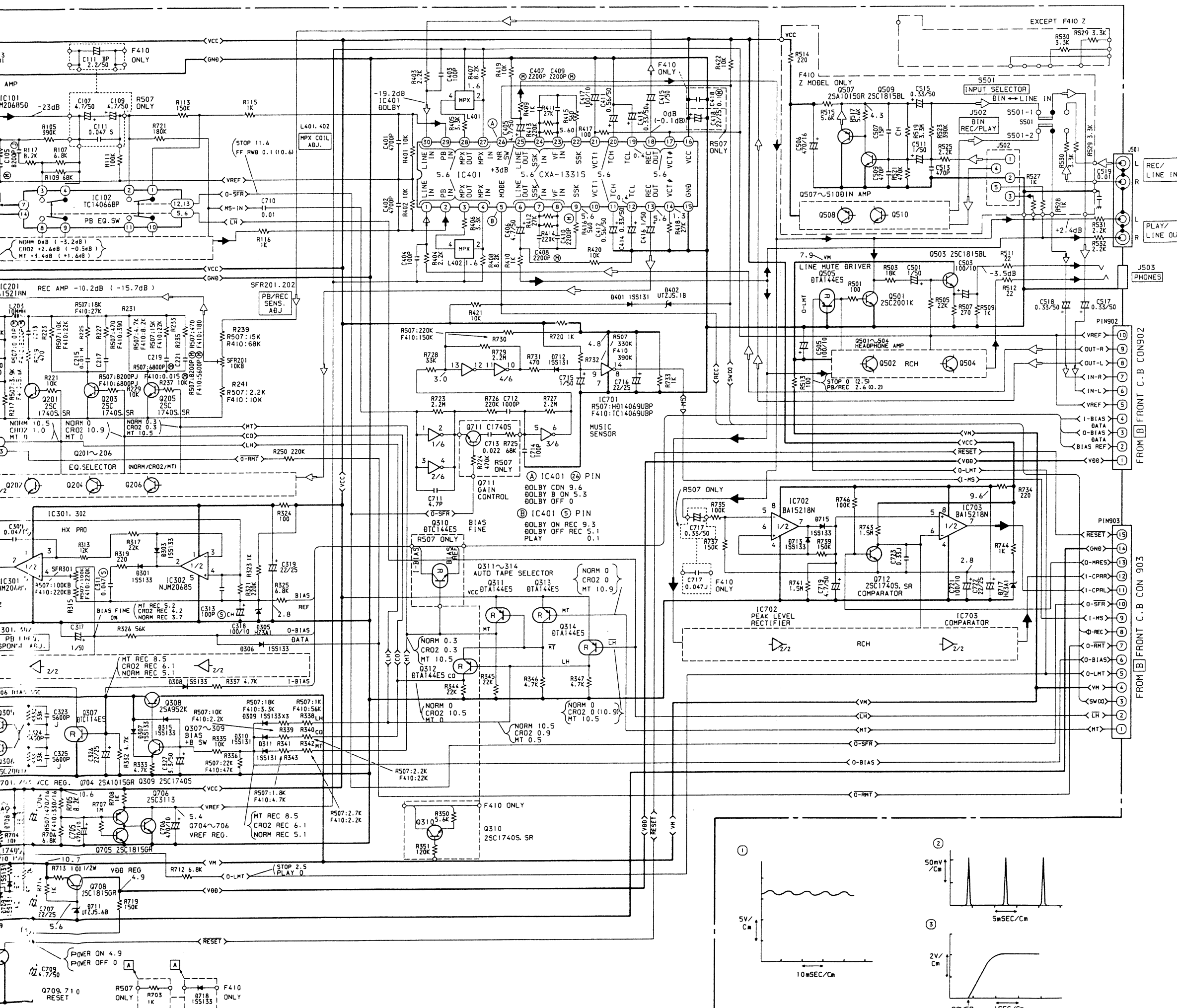



A B C D E F G H I J K

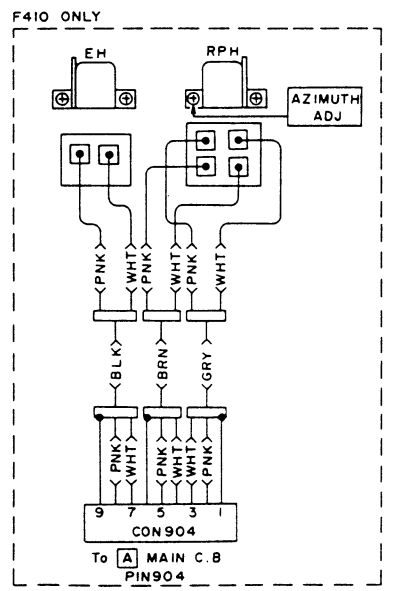
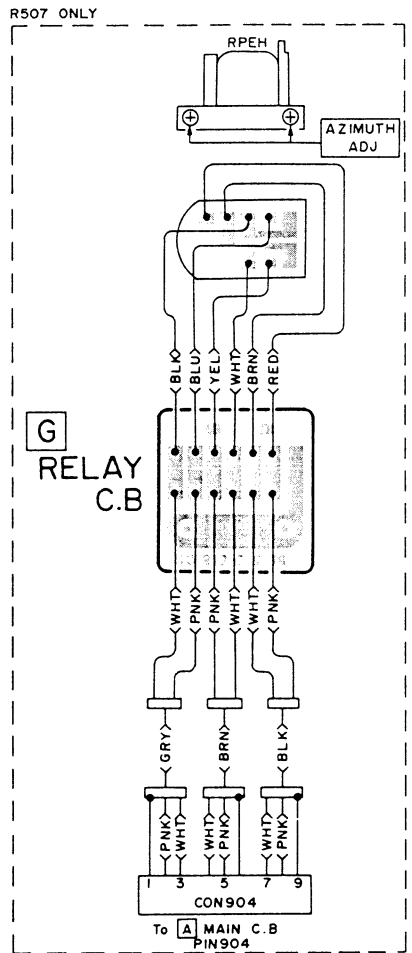
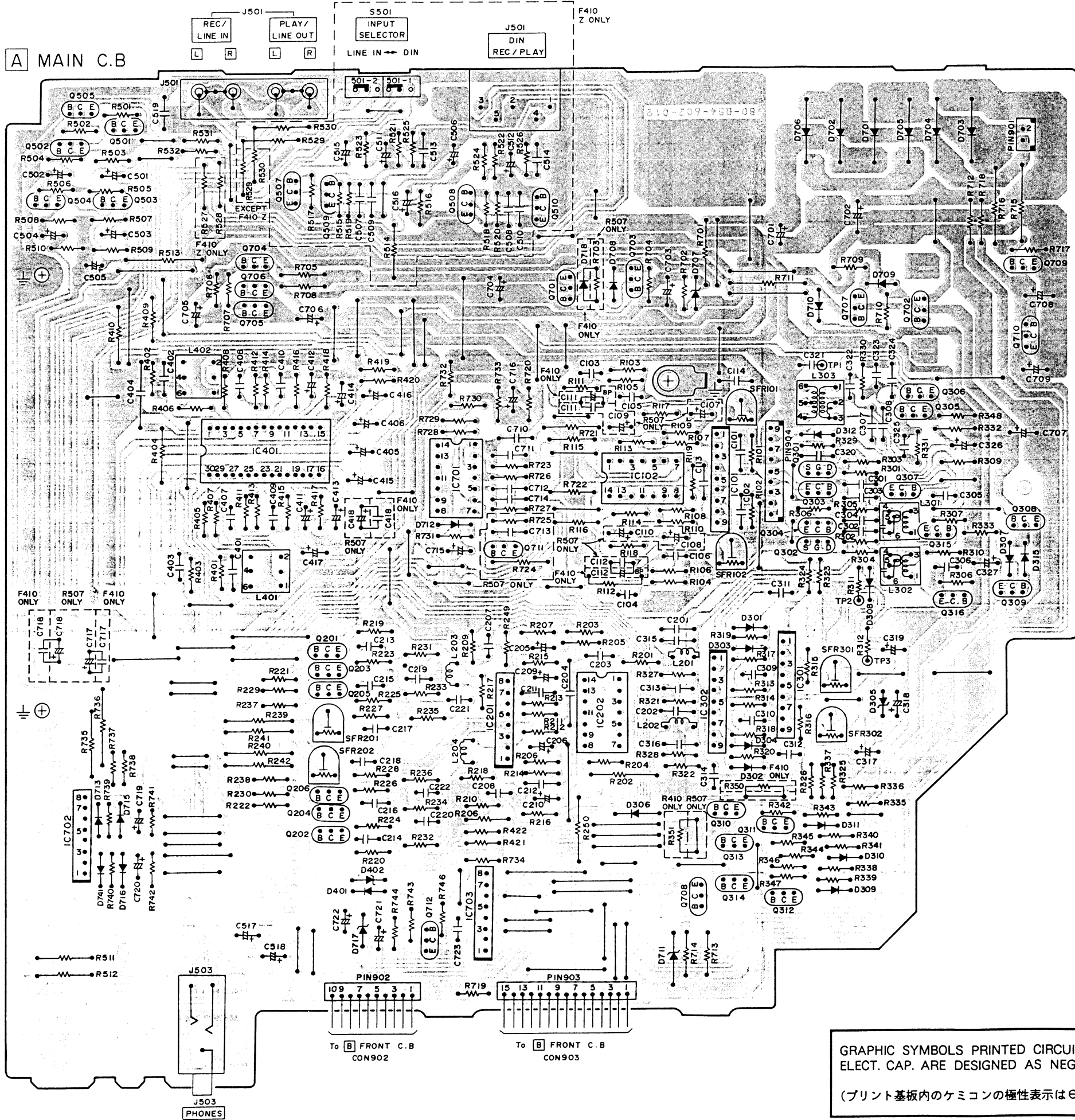

GRAPHIC SYMBOLS PRINTED CIRCUIT BOARD OF ELECT. CAP. ARE DESIGNED AS NEGATIVE POLE.  
 (プリント基板内のケミコンの極性表示は⊖表示です。)



A  
B  
C  
D  
E  
F  
G  
H  
I  
J  
K

**B FRONT C.B.**

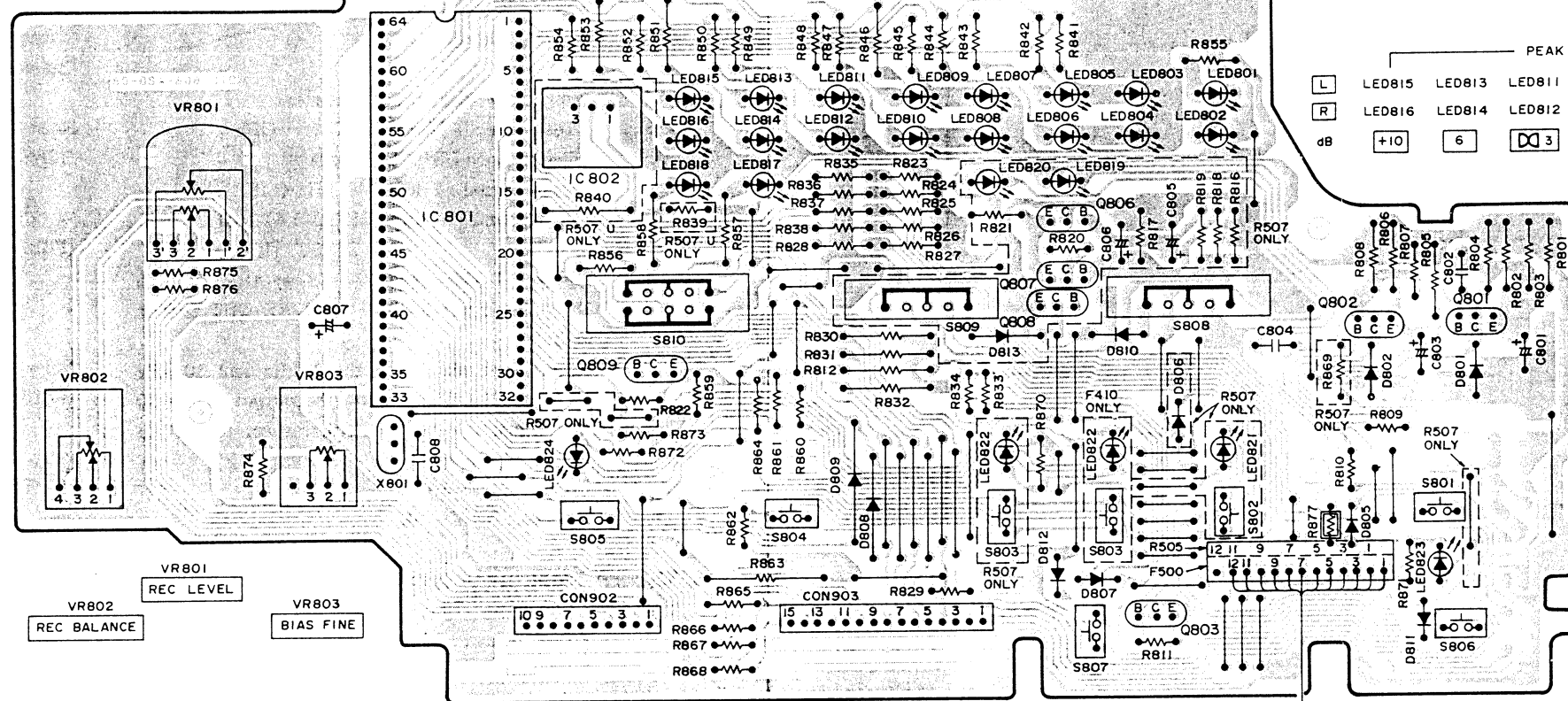

PEAK HOLD METER

L	LED815	LED813	LED811	LED809	LED807	LED805	LED803	LED801
R	LED816	LED814	LED812	LED810	LED808	LED806	LED804	LED802
dB	+10	6	3	0	5	10	20	-∞

**D POWER SW C.B.**

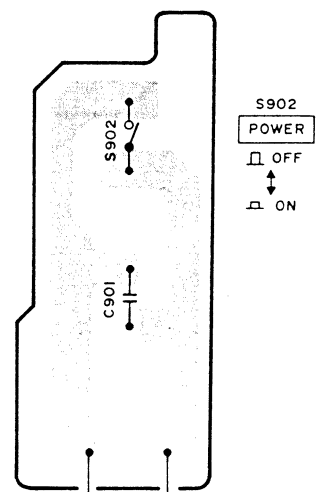

**E DECK C.B.**

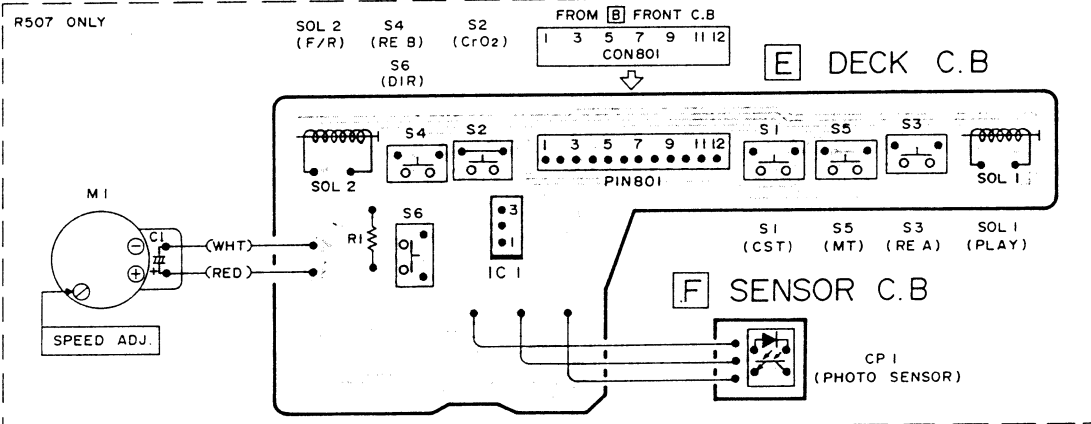

**F SENSOR C.B.**

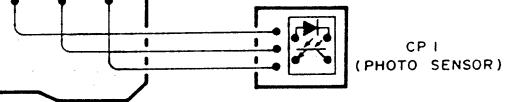

**E DECK C.B.**

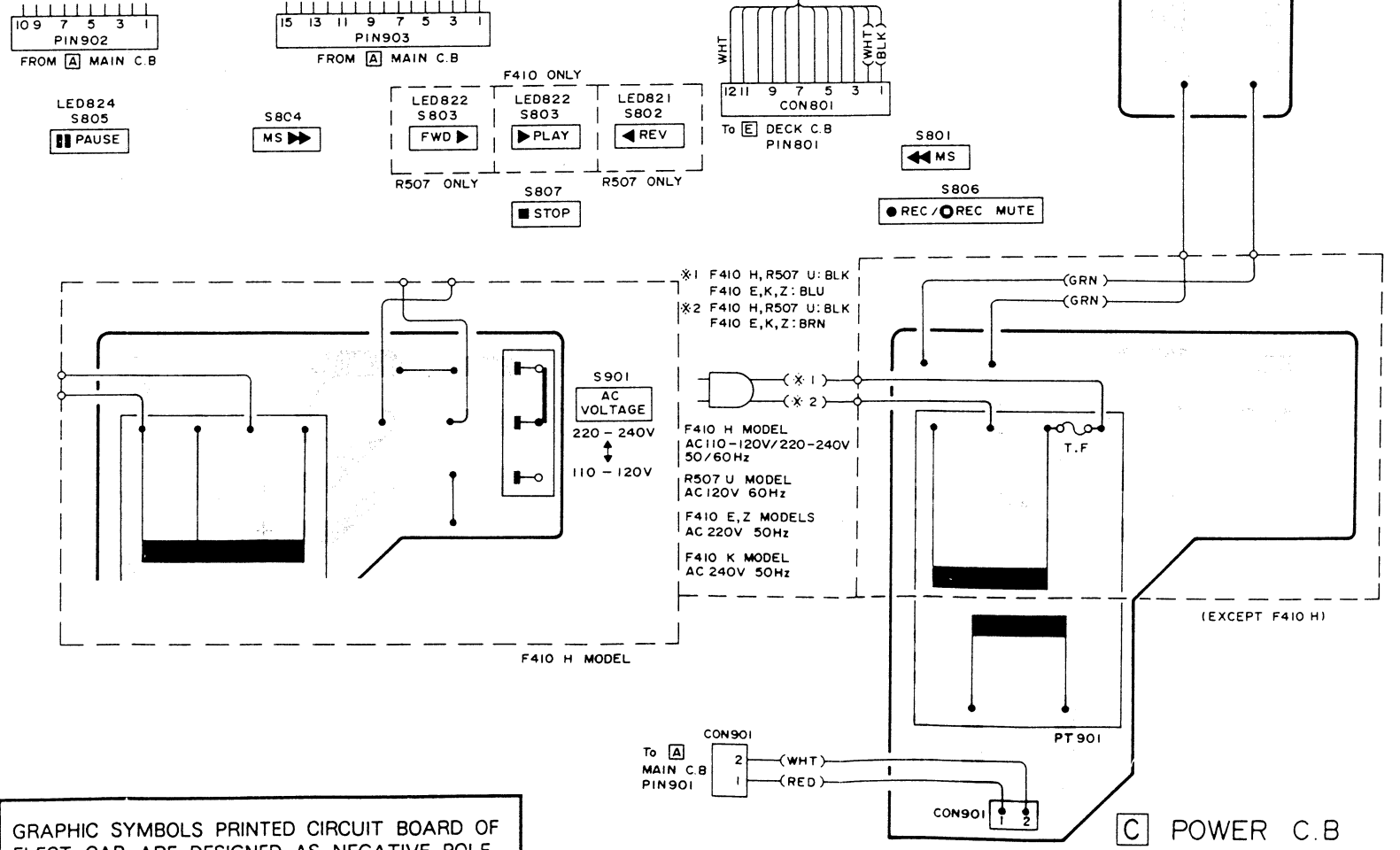
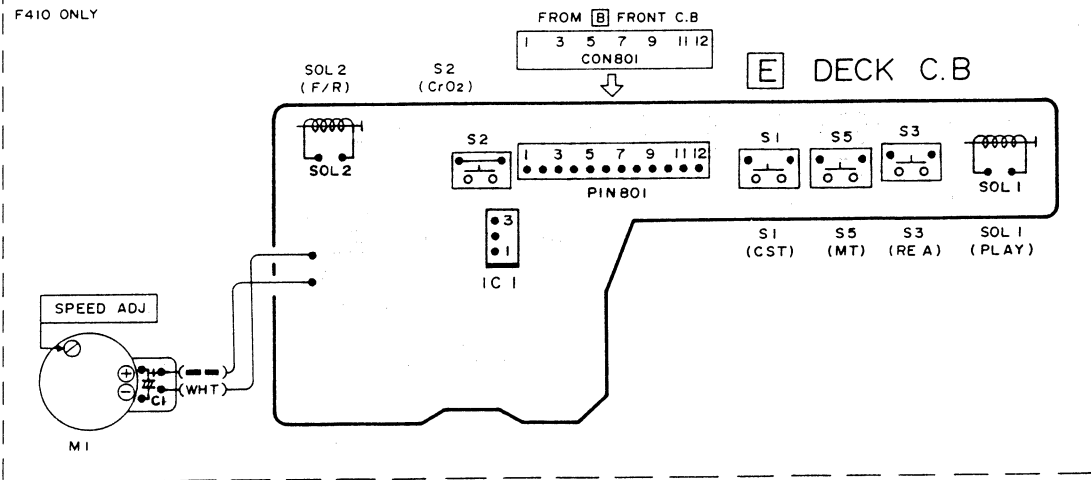

**C POWER C.B.**

GRAPHIC SYMBOLS PRINTED CIRCUIT BOARD OF ELECT. CAP. ARE DESIGNED AS NEGATIVE POLE.

(プリント基板内のケミコンの極性表示は⊖表示です。)

# ADJUSTMENT

## A MAIN C.B

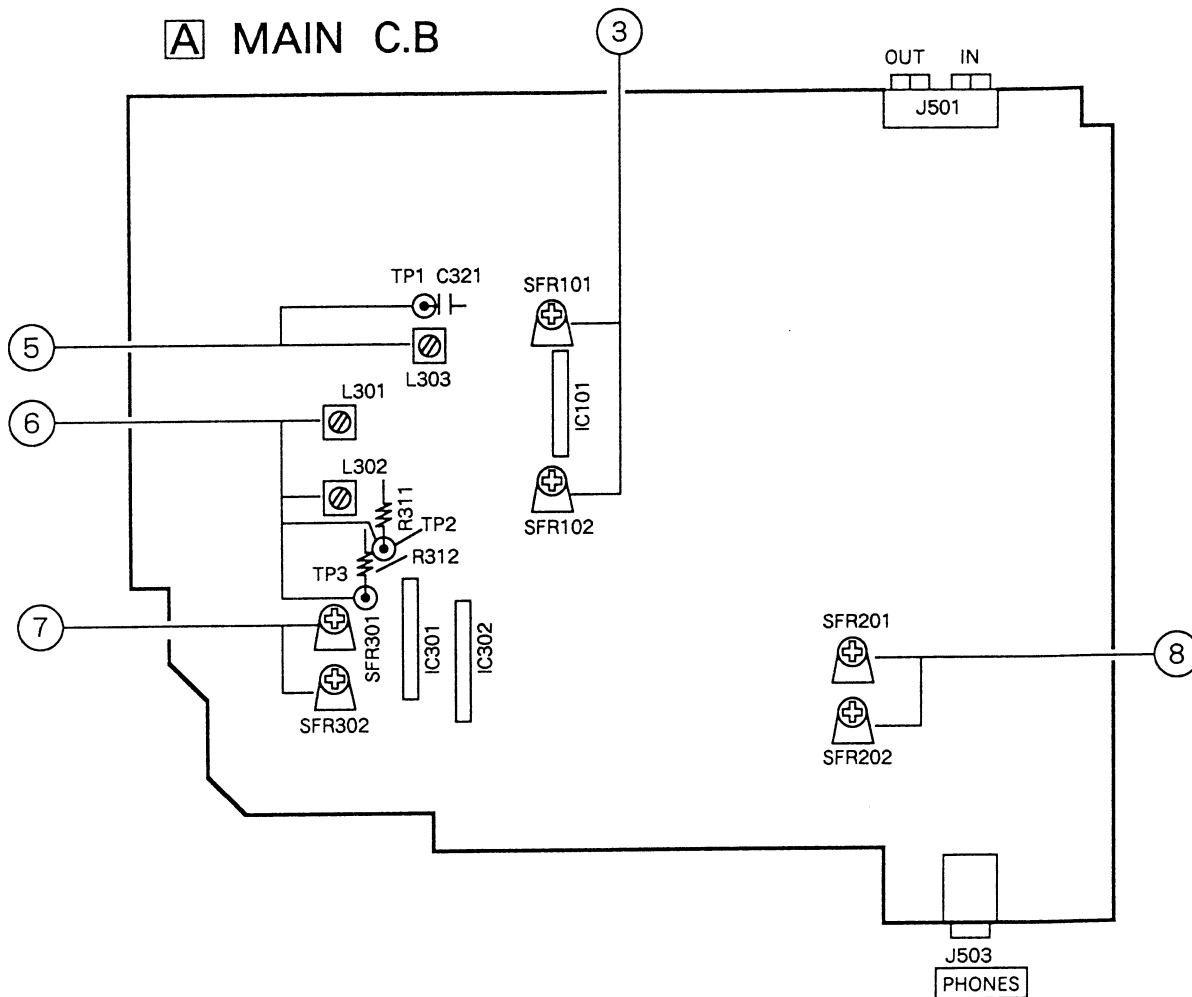

### Initial Settings

1. REC LEVEL : MAX
2. BIAS FINE : Center click position
3. REC BALANCE : Center click position
4. REC CALIBRATION : Center click position
5. DOLBY NR SW : OFF
6. TIMER SW : OFF

### 1. Tape Speed Adjustment

- Settings : • Test tape : TTA - 100 (TTA - 111S)  
 • Test point : LINE OUT jack  
 • Adjustment Location : SFR inside motor
- Method : Play back the test tape, adjust for 3000 Hz.

### 2. Head Azimuth Adjustment

- Settings : • Test tape : TTS - 310 (TTA - 317E, SCC - 1429)  
 • Test point : LINE OUT jack  
 • Adjustment Location : Head azimuth adjustment screw
- Method : Play back the 10 kHz signal of the test tape and adjust so that the output becomes maximum.

### 3. PB Sensitivity Adjustment

- Settings : • Test tape : TTS - 200 (TTA - 161, TCC - 130)  
 • Test point : LINE OUT jack  
 • Adjustment Location : SFR101 (L ch)  
 SFR102 (R ch)
- Method : Play back the test tape and adjust so that the output level is 500 mV.

### 4. PB Frequency Response Check

- Settings : • Test tape : TTS - 310 (TTA - 317E, SCC - 1429)  
 • Test point : LINE OUT jack
- Method : Play back the 315 Hz and 10 kHz signals of the test tape and check the output of the 10 kHz signal is 0 dB ± 2.5 dB with respect to that of the 315 Hz signal.

### 5. Bias Frequency Adjustment

- Settings : • Test tape : TTA - 620 (TTA - 119MP)  
 • Test point : TP1  
 • Adjustment Location : L303
- Method : Set to the record mode and adjust so that the frequency counter reads 85 kHz.



IC DESCRIPTION

IC,LC6554H-4489

Pin No.	Pin Name	I/O	Description
1	LED-R2	O	Level meter LED display output (Rch -5 dB). active "H"
2, 3	LED-R1	O	Level meter LED display output (Rch -10 dB). active "H"
4	LED-R0	O	Level meter LED display output (Rch -20 dB). active "H"
5	LED-L2	O	Level meter LED display output (Lch -5 dB). active "H"
6, 7	LED-L1	O	Level meter LED display output (Lch -10 dB). active "H"
8	LED-L0	O	Level meter LED display output (Lch -20 dB). active "H"
9	NC	-	Not used.
10	I-QUICK	I	QUICK reverse detection input. "H" input during quick reverse. (AD-R505 only).
11	I-REEL	I	Reel path detection input.
12	I-SW CST	I	Cassette detection switch. "L" when a cassette is loaded.
13	I-SW CO	I	CrO <sub>2</sub> hole detection switch. "H" when cassette uses CrO <sub>2</sub> tape. (Connected to GND)
14	I-SW REA	I	Erase prevention detection switch for side A. "L" when side A is recordable.
15	I-SW REB	I	Erase prevention detection switch for side B. "L" when side B is recordable.
16	I-SW MT	I	Metal hole detection switch. "H" when cassette used metal tape. (Connected to GND)
17	I-SW DIR	I	Direction detection switch. "L" for side A.
18	I-REMOTE	I	Remote control input.
19	I-KRES	I	Counter reset input. (Connected to GND)
20	O-RMTR	O	Reel motor control output. "L" when reel motor is rotating.
21	O-LMT	O	Line mute output. "H" during muting. "L" in REV mode during recording.
22	O-BIAS	O	Bias oscillator control output. "L" in REV mode.
23	O-CMTR	O	Capstan motor control output. "L" when capstan motor is rotating and the power is on for AUTO SENSOR/QUICK SENSOR.
24	O-RMT	O	REC mute control output. "L" during muting. All "L" in other than REC PLAY mode.
25	O-REC	O	DOLBY IC record switch. "H" when recording.
26	KS0	O	DATA0 - DATA6 KEY SCAN Output.
27	KS1	O	
28	DISP	O	DATA0 - DATA6 LED scan output.
29	I-RVS	I	REVERSE mode input. "L" during REVERSE mode.
30	TEST	-	CPU test terminal. Connected to GND.
31	VSS	-	Connected to GND.
32	OSC1	-	4 MHz clock oscillator terminal.
33	OSC2	-	
34	RESET	-	CPU reset terminal.
35	O-NOR	O	Output for display indicating normal tapes. (Connected to GND)
36	O-CO	O	Output for display indicating CrO <sub>2</sub> tapes. (Connected to GND)

Pin No.	Pin Name	I/O	Description		
37	O-MT	O	Output for display indicating metal tapes. (Connected to GND)		
38	O-MRES	O	Output for 8-point peak meter.		
39	I-CPRR	I	Right channel peak meter input.		
40	I-CPRL	I	Left channel peak meter input.		
41	O-SFRP	O	F/R solenoid control output. "L" when solenoid bar is drawn into coil.		
42	O-SPLY	O	PLAY solenoid control output. "L" when solenoid bar is drawn into coil.		
43	I-MS	I	Music sensor detect input. "L" when music sensor is on.		
44	D0	O	KSO	KSI	DISP
			—	SW ↔ (AD-R507 only)	LED PAUSE
45	D1	O	—	—	—
46	D2	O	KEY PAUSE	SW ↻ (AD-R507 only)	LED REC/RMT
47	D3	O	KEY ▷▷	KEY STOP	LED PLAY-FWD
48	D4	O	KEY ▷	KEY REC/RMT	LED PLAY-REV (AD-R507 only)
49	D5	O	KEY ◁ (AD-R507 only)	SW TIMER REC	LED ▷▷ (AD-R507 only)
50	D6	O	KEY ◁◁	SW TIMER PLAY	LED ◁◁ (AD-R507 only)
51	-VP	-	Makes plate voltage connection for flourescent .		
52	LED-R6	O	Level meter LED display output (Rch +10 dB). active "H"		
53	LED-R5	O	Level meter LED display output (Rch +6 dB). active "H"		
54	LED-R4	O	Level meter LED display output (Rch +3 dB). active "H"		
55	NC	-	Not used.		
56	LED-L6	O	Level meter LED display output (Lch +10 dB). active "H"		
57	LED-L5	O	Level meter LED display output (Lch +6 dB). active "H"		
58	LED-L4	O	Level meter LED display output (Lch +3 dB). active "H"		
59	NC	-	Not used.		
60, 61	LED-R3	O	Level meter LED display output (Rch 0 dB). active "H"		
62, 63	LED-L3	O	Level meter LED display output (Lch 0 dB). active "H"		
64	VDD	-	CPU power supply terminal. (+5 V)		

# EXPLODED VIEW - 1

REF. NO.	PART NO.	DESCRIPTION
A	87-067-660-019	BVT2+3-8 W/O SLOT (B)
B	87-067-703-019	BVT2+3-10 W/O SLOT
C	87-067-688-019	BVTT+3-6
D	87-661-096-419	VFT1+3-10
E	87-591-094-419	QIT+3-6
F	87-067-585-019	BVTT+4-6
G	87-067-776-019	BVT2+3-12 W CONVEX
H	87-067-758-019	BVT2+3-12 W/O SLOT
I	87-067-579-019	BVT2+3-8 W/O SLOT
J	87-571-092-419	VIT+3-4
K	81-653-215-019	SPECIAL SCREW VT2

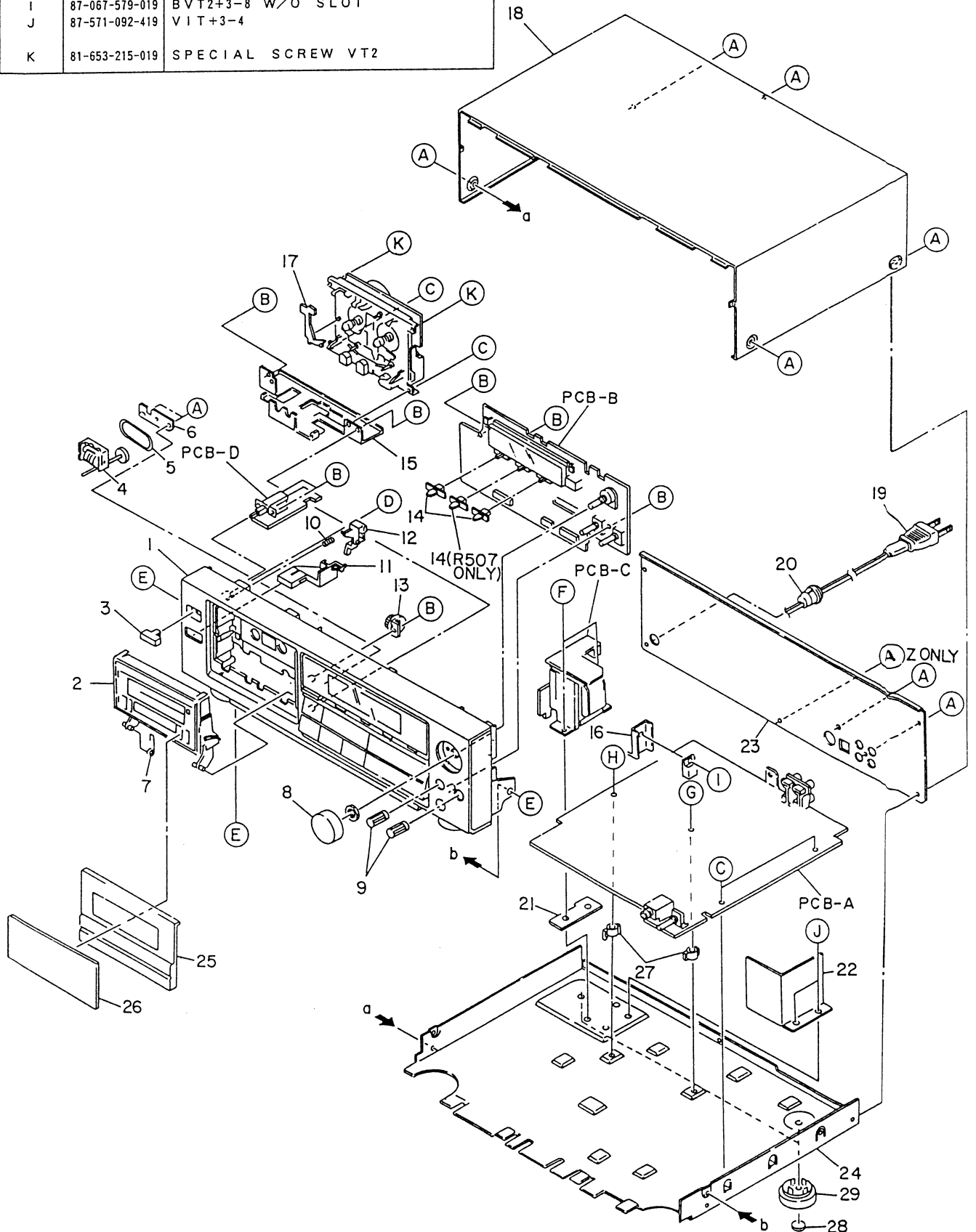



# MECHANICAL PARTS LIST

PART NO. CHANGED TO	REF. NO.	PART NO.	DESCRIPTION	COMMON MODEL	Q' TY
	1-1	★09-047-665-010	FRONT CABINET ASSY (R507)	※	1
	1-1	★09-047-657-010	FRONT CABINET ASSY (F410)	※	1
	1-2	★09-047-509-010	CASSETTE BOX ASSY (R507)	※	1
	1-2	★09-047-508-010	CASSETTE BOX ASSY (F410)	※	1
	1-3	★84-721-023-010	BUTTON, POWER		1
	1-4	★87-040-199-010	COUNTER		1
	1-5	★80-DS4-202-010	BELT, SQ 0.8-199.6	※	1
	1-6	★82-205-208-010	HOLDER, COUNTER		1
	1-7	★80-DS3-202-019	T-SPRING, EJECT 1		1
	1-8	★82-235-014-119	KNOB, REC (R507)		1
	1-8	★81-DS2-021-010	KNOB, REC (F410)		1
	1-9	★80-DS3-007-019	KNOB, BIAS		2
	1-10	★80-DS3-209-019	C-SPRING, EJECT		1
	1-11	★84-793-011-010	BUTTON, EJECT		1
	1-12	★80-DS3-203-019	LEVER, EJECT		1
	1-13	★87-063-143-010	DAMPER, OIL 75		1
	1-14	★80-DW1-012-019	KNOB, SLIDE		3(R507) 2(F410)
	1-15	★80-DS3-204-019	PLATE, SHIELD		1
	1-16	---	HEAT SINK		1
	1-17	★82-235-204-010	LEVER, PROTECT		1
	1-18	★80-DS3-002-019	CABINET, STEEL		1
	1-19	★87-034-583-019	CORD, AC (R507)		1
	1-19	★87-034-749-019	CORD, AC (F410 H)		1
	1-19	★82-187-797-019	CORD, AC (F410 E, Z)		1
	1-19	★82-187-796-019	CORD, AC (F410 K)		1
	1-20	★87-085-184-010	BUSHING, AC (R507, F410 H)		1
	1-20	★87-085-185-010	BUSHING, AC (F410 E, Z)		1
	1-20	★87-085-189-010	BUSHING, AC (F410 K)		1
	1-21	★80-DW1-209-019	PLATE, PT		1
	1-22	★80-DS4-599-019	PLATE, SHIELD	※	1
	1-23	★80-DS4-017-019	PANEL, REAR (R507)	※	1
	1-23	★81-DS3-008-019	PANEL, REAR (F410 H)	※	1
	1-23	★81-DS3-010-019	PANEL, REAR (F410 E)	※	1
	1-23	★81-DS3-011-019	PANEL, REAR (F410 K)	※	1
	1-23	★81-DS3-013-019	PANEL, REAR (F410 Z)	※	1
	1-24	---	CHASSIS, MAIN		1
	1-25	★80-DS3-003-019	PANEL, CASSETTE		1
	1-26	★80-DS3-008-010	WINDOW, CASSETTE (R507)		1
	1-26	★81-DS3-003-010	WINDOW, CASSETTE (F410)	※	1
	1-27	★80-DS3-205-010	HOLDER, P. C. B 5.6		2
	1-28	★80-DS3-206-019	CUSHION, G DIA 15-1		2
	1-29	★80-DS3-014-119	FOOT, REAR ST (R507)		2
	1-29	★81-669-018-019	FOOT, REAR (F410)		2

# EXPLODED VIEW - 2

REF. NO.	PART NO.	DESCRIPTION
A	87-067-470-010	PW4, 1-6.9-0.13
B	86-524-418-019	VFT2+1.4-5
C	87-067-177-019	V+1.6-5.5
D	87-081-489-019	PW1, 7-3.5-0.25
E	87-067-174-019	VTT+2-4
F	87-067-362-019	V+2-6.6
G	87-353-034-219	VT2+2-5
H	87-267-033-019	V+2-4 [B]
I	86-575-236-010	S-SCREW, TAPE ADJ

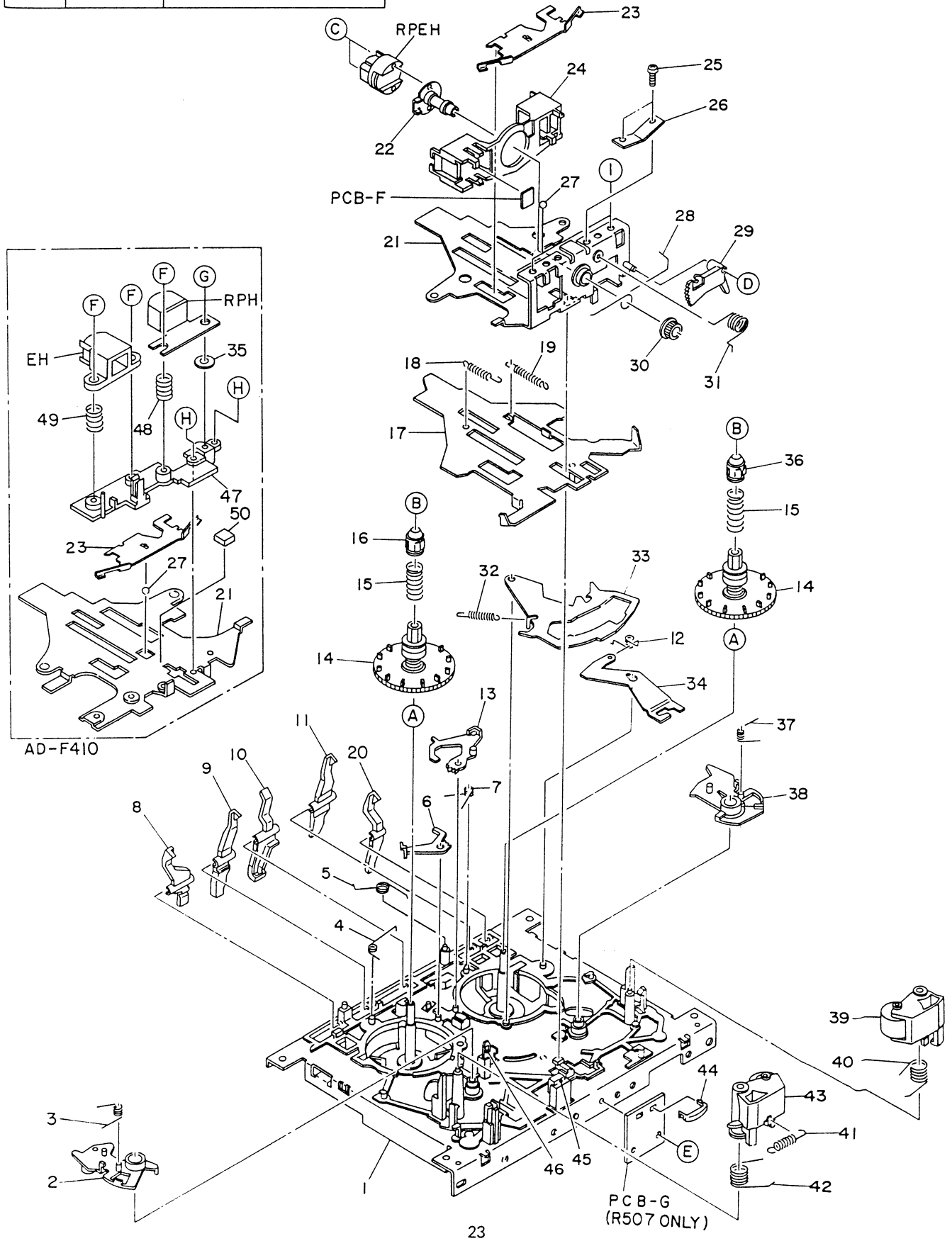

PART NO. CHANGED TO	REF. NO.	PART NO.	DESCRIPTION	COMMON MODEL	Q' TY
	2-1	★86-575-217-710	MECHANISM CHASSIS ASSY (R507)	※	1
	2-1	★86-575-239-610	MECHANISM S CHASSIS ASSY (F410)	※	1
	2-2	★86-535-239-110	LEVER, PLAY R (R507)		1
	2-3	★86-535-283-019	T-SPRING, PLAY GEAR R (R507)		1
	2-4	★86-575-351-010	T-SPRING, BRAKE RS	※	1
	2-5	★86-575-225-019	T-SPRING, CASSETTE	※	1
	2-6	★86-535-252-210	LEVER, BRAKE R		1
	2-7	★86-535-370-019	T-SPRING, BRAKE F		1
	2-8	★86-535-247-210	LEVER, REC GUARD A		1
	2-9	★86-535-250-110	LEVER, METAL		1
	2-10	★86-535-249-210	LEVER, CASSETTE SENSOR		1
	2-11	★86-535-254-110	LEVER, CR		1
	2-12	★86-535-277-010	T-SPRING, D SW (R507)		1
	2-13	★86-535-251-110	LEVER, BRAKE F		1
	2-14	★86-535-240-610	REEL TABLE R ASSY		2
	2-15	★86-535-293-019	C-SPRING, REEL TABLE		2
	2-16	★86-524-218-219	STOPPER, REEL TABLE S		1
	2-17	★86-535-215-310	SLIDE PLATE ASSY (R507)		1
	2-17	★86-535-385-210	SLIDE S PLATE ASSY (F410)		1
	2-18	★86-575-227-010	E-SPRING, LEVER SLIDE (R507)	※	1
	2-18	★86-535-285-119	E-SPRING, SLIDE (F410)		1
	2-19	★86-575-226-019	E-SPRING, CHASSIS HEAD (R507)	※	1
	2-19	★86-535-286-019	E-SPRING, OPERATION (F410)		1
	2-20	★86-535-248-310	LEVER, REC GUARD B (R507)		1
	2-21	★86-575-209-210	CHASSIS, HEAD S (R507)	※	1
	2-21	★86-535-311-410	CHASSIS, HEAD S (F410)		1
	2-22	★86-575-207-110	HOUSING HEAD ASSY (R507)	※	1
	2-23	★86-535-289-110	P-SPRING, HEAD CHASSIS		1
	2-24	★86-575-214-110	GUIDE, TAPE (R507)	※	1
	2-25	★86-575-235-019	SCREW, S AZIMUTH (R507)	※	2
	2-26	★86-524-300-119	P-SPRING, AZIMUTH (R507)		1
	2-27	★87-073-018-019	BALL, STEEL 1.588		1
	2-28	★86-575-240-010	T-SPRING, GUIDE (R507)	※	1
	2-29	★86-535-246-210	GEAR, SEGMENT (R507)		1
	2-30	★86-575-206-010	GEAR, HEAD FR (R507)	※	1
	2-31	★86-535-290-010	T-SPRING, SEGMENT GEAR (R507)		1
	2-32	★86-535-284-010	E-SPRING, DIRECTION LEVER (R507)		1
	2-33	★86-535-218-210	LEVER DIRECTION ASSY (R507)		1
	2-34	★86-575-219-010	LEVER, D SW (R507)	※	1
	2-35	★86-535-387-010	MYLAR, W 2.3-5-0.188 (F410)		1
	2-35	★86-535-363-019	SHEET, MYLAR 2.3-5-0.1 (F410)		1
	2-36	★86-524-233-219	STOPPER, REEL TABLE T		1
	2-37	★86-535-282-019	T-SPRING, PLAY GEAR F		1
	2-38	★86-535-238-210	LEVER, PLAY F		1
	2-39	86-535-226-210	PINCH LEVER F ASSY		1
	2-40	★86-575-222-110	T-SPRING, PINCH F (R507)	※	1
	2-40	★86-535-312-010	T-SPRING, PINCH S (F410)		1
	2-41	★86-535-287-119	E-SPRING, PINCH (R507)		1
	2-42	★86-575-223-110	T-SPRING, PINCH R (R507)	※	1
	2-43	86-535-228-310	PINCH LEVER R ASSY (R507)		1
	2-44	---	HOLDER, WIRE (R507)		1
	2-45	★86-535-353-019	FELT, SQ 5-4-2		1
	2-46	★86-517-353-019	SHEET, QUICK (R507)		1
	2-47	★86-535-314-210	BASE, HEAD (F410)		1
	2-48	★86-535-359-010	C-SPRING, AZIMUTH S (F410)		1
	2-49	★86-575-321-010	C-SPRING, AZIMUTH S 2 (F410)	※	1
	2-50	★86-575-360-019	CUSHION, G 3.8-3.8-2 (F410)	※	1

# EXPLODED VIEW - 3

REF. NO.	PART NO.	DESCRIPTION
A	87-081-501-019	VTT+2.6-4
B	86-575-243-019	MOTOR SCREW
C	87-067-332-019	PW2.8-4.7-0.13
D	87-081-489-019	PW1.7-3.5-0.25
E	87-067-380-019	PW1.7-7-0.5

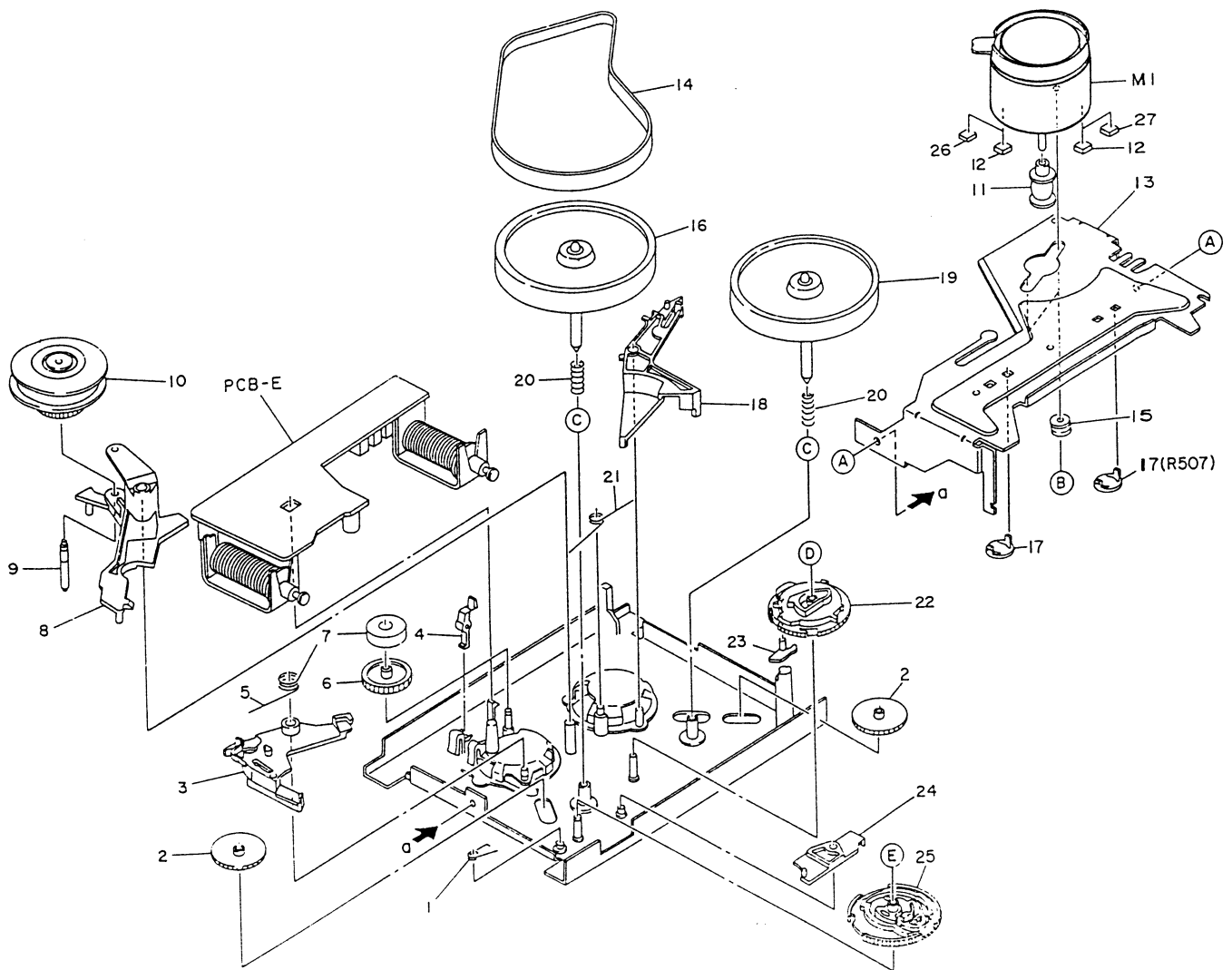

PART NO. CHANGED TO	REF. NO.	PART NO.	DESCRIPTION	COMMON MODEL	Q' TY
	3-1	★86-535-291-210	T-SPRING, FR CAM		1
	3-2	★86-535-259-310	GEAR, PLAY (R507)		2
	3-2	★86-575-221-210	GEAR, PLAY (F410)	※	1
	3-3	★86-535-230-510	LEVER, TRIGGER FR		1
	3-4	★86-535-253-210	LEVER, RINK (R507)		1
	3-5	★86-535-278-019	T-SPRING, FR		1
	3-6	★86-575-220-010	GEAR, IDLER	※	1
	3-7	★86-535-614-010	RING, MAGNET		1
	3-8	★86-535-233-210	LEVER, FR		1
	3-9	★86-535-235-010	SHAFT, FR		1
	3-10	★86-575-314-010	SLIP DISK ASSY	※	1
	3-11	★86-535-389-110	PULLEY, MOTOR C		1
	3-12	★86-575-261-110	CUSHION, G 5.5-1.5 (R507)	※	2
	3-13	★86-575-218-210	HOLDER, MOTOR	※	1
	3-14	★86-575-224-010	BELT, 2 (R507)	※	1
	3-14	★86-575-238-010	BELT, 3 (F410)	※	1
	3-15	★86-575-242-010	CUSHION, G DIAL 3.7-9-3.2	※	2
	3-16	★86-535-395-010	FLYWHEEL FD ASSY (F410)		1
	3-16	★86-575-203-110	FLYWHEEL F ASSY (R507)	※	1
	3-17	★86-535-255-010	RETAINER, FLYWHEEL		2(R507) 1(F410)
	3-18	★86-535-231-410	LEVER, TRIGGER PLAY		1
	3-19	★86-575-201-110	FLYWHEEL R ASSY (R507)	※	1
	3-20	★86-535-288-019	C-SPRING, FLYWHEEL		2(R507) 1(F410)
	3-21	★86-535-279-010	T-SPRING, MAIN		1
	3-22	★86-535-260-310	CAM, MAIN		1
	3-23	★86-535-308-110	LEVER, CHANGE (R507)		1
	3-24	★86-575-229-210	LEVER, PAUSE B (R507)	※	1
	3-24	★86-535-223-310	LEVER, PAUSE (F410)		1
	3-25	★86-535-261-410	CAM, FRP		1
	3-26	★86-575-597-010	CUSHION, G 6-6-2 (F410)		1
	3-27	★86-575-261-110	CUSHION, G 5.5-1.5 (F410)		1

# SPRING APPLICATION POSITION

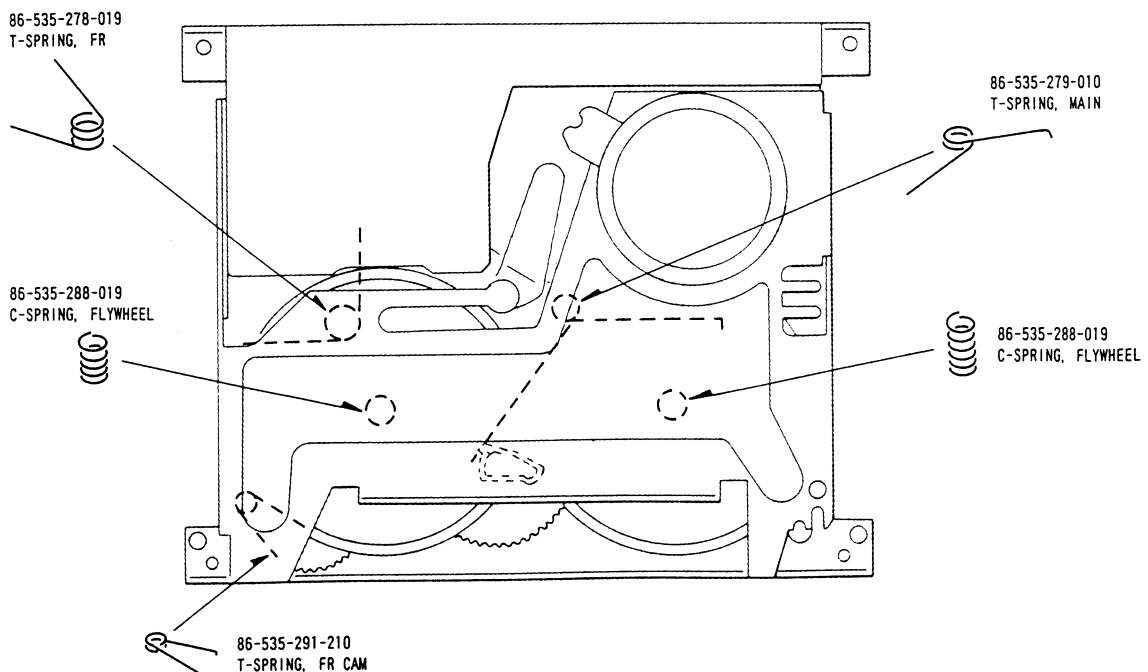
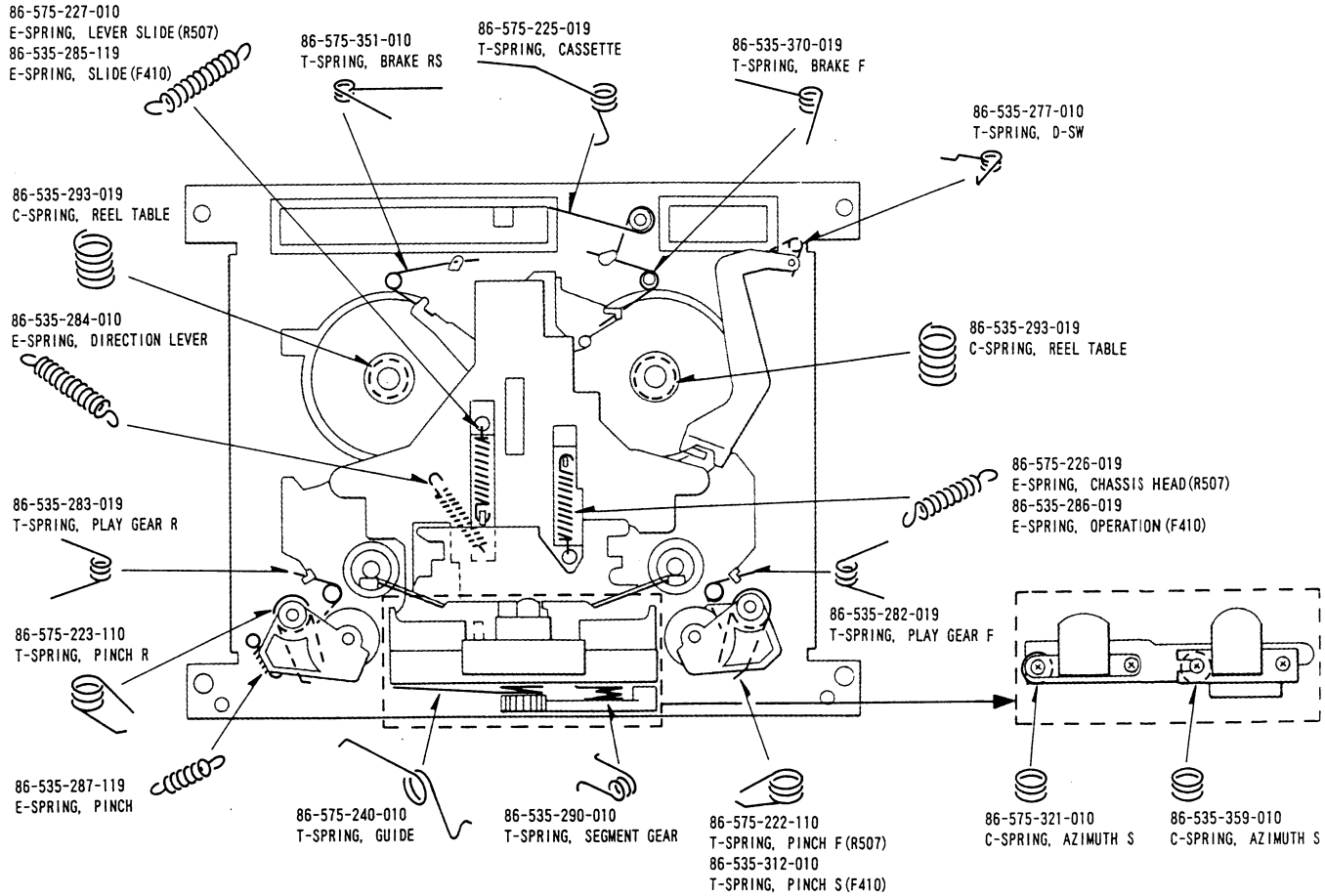

## ■ ACCESSORIES/PACKAGE LIST

PART NO. CHANGED TO	REF. NO.	PART NO.	DESCRIPTION	COMMON MODEL	Q,TY
	1	★80-DS4-906-019	INSTRUCTION BOOKLET,U (R507)	※	1
	2	★81-DS3-901-019	INSTRUCTION BOOKLET,EX (F410)	※	1
	3	★87-034-786-019	CORD PIN,189 - 0760		1
	4	★87-032-845-019	PLUG,CONVERSION (F410 HJ)		1
	5	★80-DS4-621-019	REMOTE UNIT,C - ASSY RC - R102 (R507)	※	1