

# SERVICE MANUAL

---

MINIDISC PLAYER

BASIC MD MECHANISM : ZZG-5 B

---

- This Service Manual is the "Revision Publishing" and replaces "Simple Manual" (S/M Code No. 09-003-430-9T1).

# SPECIFICATIONS

## Main unit

<b>Playback system</b>	MiniDisc digital audio system
<b>Laser pickup</b>	Semiconductor laser
<b>Sampling Frequency</b>	44.1 kHz
<b>Number of channels</b>	Stereo: 2 channels
<b>D/A converter</b>	1-bit
<b>Frequency response</b>	40 to 20,000 Hz $\pm$ 4 dB 20 to 20,000 Hz $\pm$ 1 dB (10 k $\Omega$ )
<b>Wow and Flutter</b>	Below measurable limit ( $\pm$ 0.00 1% W.PEAK)
<b>Output</b>	Phone jack
<b>Maximum output level</b>	8 mW + 8 mW (16 $\Omega$ )
<b>Power requirements</b>	DC 1.2 V using the supplied NI-MH rechargeable battery MHB-901 DC 1.5 V using an LR6 (size AA) dry cell battery AC house current using an optional AC adaptor
<b>Battery life</b>	Using the supplied rechargeable battery Approx. 20 hours (with power save on: approx. 26 hours) Using an LR6 (size AA) dry cell battery Approx. 35 hours (with power save on: approx. 43 hours) Using the supplied rechargeable battery and an LR6 (size AA) dry cell battery Approx. 60 hours (with power save on: approx. 70 hours)
<b>Maximum outside dimensions</b>	Approx. 80 (W) X 20.4 (H) X 82.8 (D) mm (3 $\frac{1}{4}$ X 1 $\frac{3}{16}$ X 3 $\frac{3}{16}$ inches) (excluding projected parts and controls)
<b>Weight</b>	Approx. 110 g (3.9 oz) including the rechargeable battery.

## <Battery charger RB-M02 K>

<b>Rated voltage</b>	AC 240 V, 50 Hz
----------------------	-----------------

- Design and specifications are subject to change without notice.

## PROTECTION OF EYES FROM LASER BEAM DURING SERVICING

This set employs laser. Therefore, be sure to follow carefully the instructions below when servicing.

### WARNING!!

WHEN SERVICING, DO NOT APPROACH THE LASER EXIT WITH THE EYE TOO CLOSELY. IN CASE IT IS NECESSARY TO CONFIRM LASER BEAM EMISSION. BE SURE TO OBSERVE FROM A DISTANCE OF MORE THAN 30cm FROM THE SURFACE OF THE OBJECTIVE LENS ON THE OPTICAL PICK-UP BLOCK.

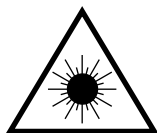

- Caution: Invisible laser radiation when open and interlocks defeated avoid exposure to beam.
- Advarsel: Usynlig laserstråling ved åbning, når sikkerhedsafbrydere er ude af funktion. Undgå udsættelse for stråling.

### VAROITUS!

Laitteen Käyttäminen muulla kuin tässä käyttöohjeessa mainitulla tavalla saattaa altistaa käyttäjän turvallisuusluokan 1 ylittävälle näkymättömälle lasersäteilylle.

### WARNING!

Om apparaten används på annat sätt än vad som specificeras i denna bruksanvisning, kan användaren utsättas för osynlig laserstrålning, som överskrider gränsen för laserklass 1.

### CAUTION

Use of controls or adjustments or performance of procedures other than those specified herein may result in hazardous radiation exposure.

### ATTENTION

L'utilisation de commandes, réglages ou procédures autres que ceux spécifiés peut entraîner une dangereuse exposition aux radiations.

### ADVARSEL

Usynlig laserstråling ved åbning, når sikkerhedsafbrydere er ude af funktion. Undgå udsættelse for stråling.

This Compact Disc player is classified as a CLASS 1 LASER product.

The CLASS 1 LASER PRODUCT label is located on the rear exterior.

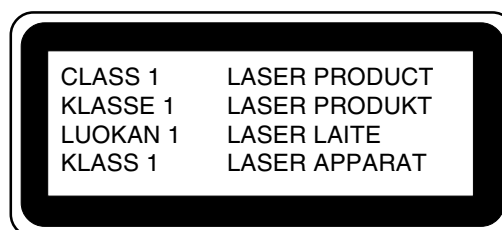

## Precaution to replace Optical block

### (KMS-330A)

Body or clothes electrostatic potential could ruin laser diode in the optical block. Be sure ground body and workbench, and use care the clothes do not touch the diode.

- 1) After the connection, remove solder shown in right figure.

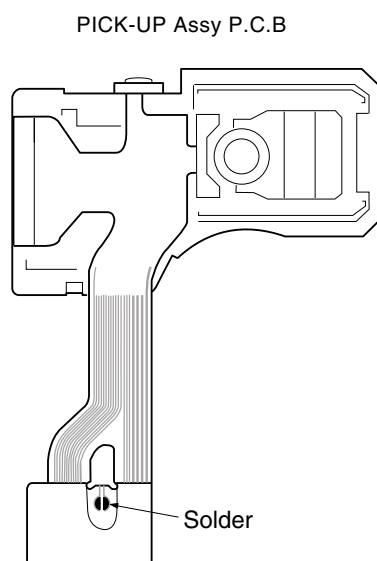

## DISASSEMBLY INSTRUCTIONS

### About Disassembling and Reassembling

Service position can be established only by removing the PANEL, BOT.

#### 1. Removing the PANEL, TOP

(1) Remove the five screws "a".

(2) Remove the PANEL, TOP.

\*1 When re-attaching the PANEL, TOP, the arm should be engaged with the HLDR, CTRG.

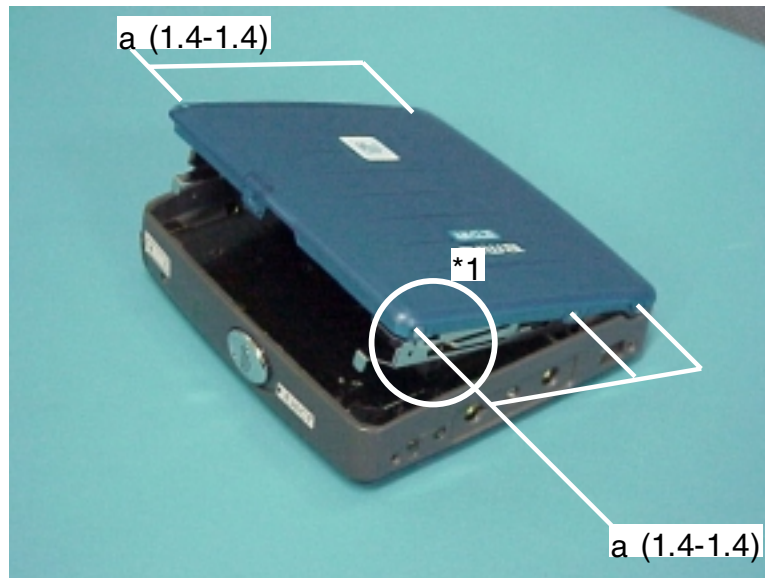

#### 2. Removing the PANEL, BOT

(1) Remove the screw "a" and the screw "b" and remove the two screws "c".

(2) While being careful not to bend the screw of the screw hole, remove the PANEL, BOT.

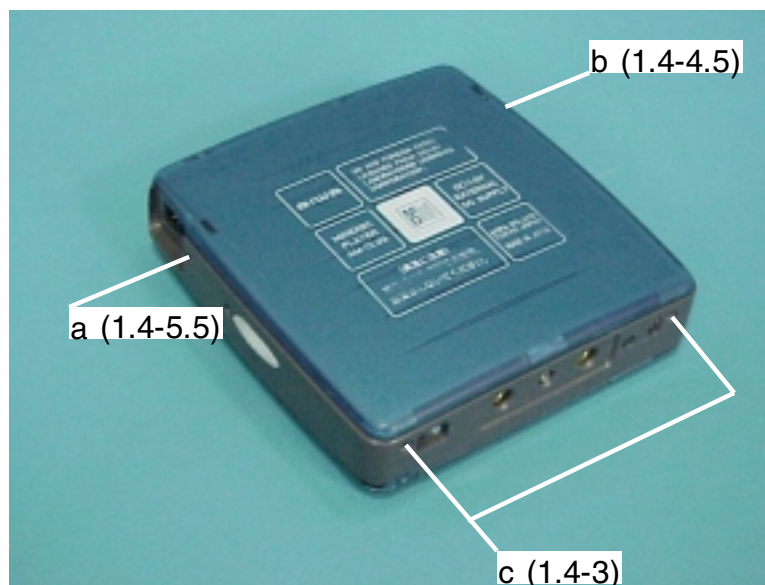

### 3. Removing the HLDR, BATT and PWB, MAIN

- (1) Remove the screw "a" and remove the HLDR, BATT.
- (2) Short the PICK-UP short land and remove the three connectors b.

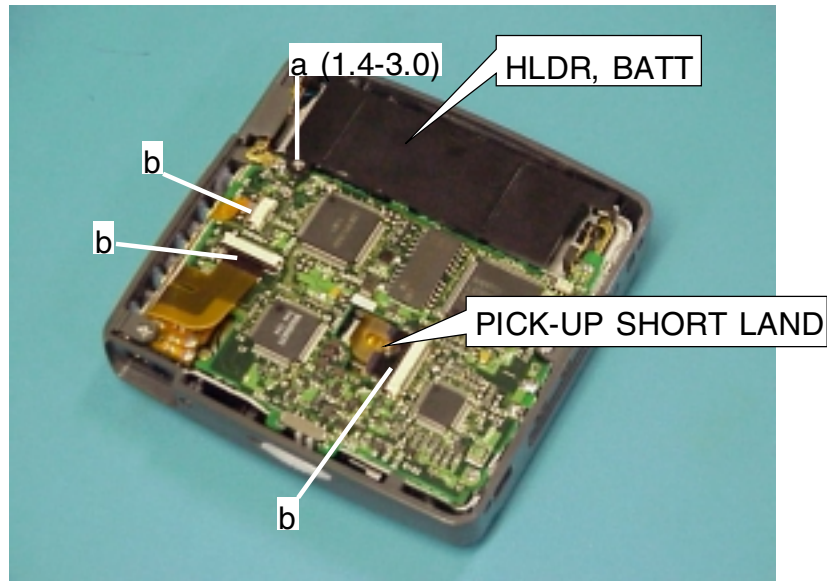

- (3) Remove the screw "c" and the three screws "d", then remove the PWB, MAIN.

\*1: Take extra caution when attaching the HOLD SW.

\*2: Take extra caution when attaching the BAT-CONTACT. In addition, take extra caution when attaching the OPEN SW that is located on the rear of the PWB, MAIN.

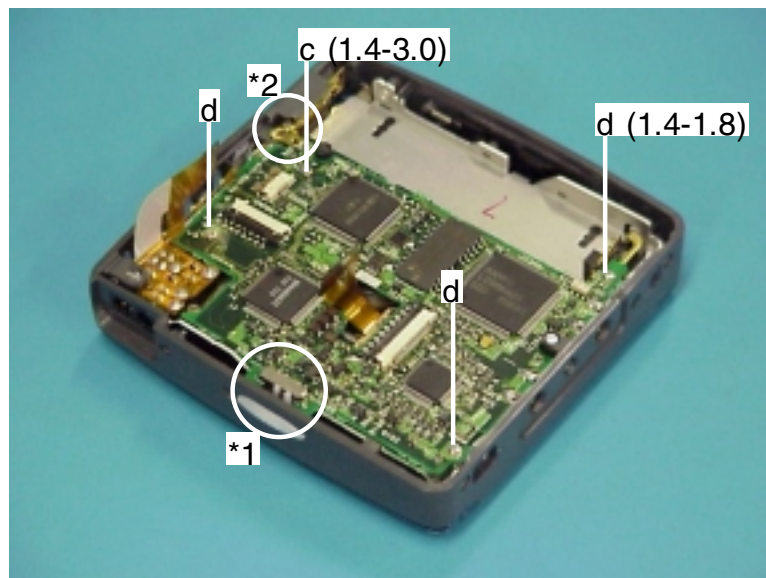

#### 4. Removing the HLDR, CTRG

(1) Bend the HLDR, CTRG in the direction of the arrow shown in the figure and remove the HLDR, CTRG.

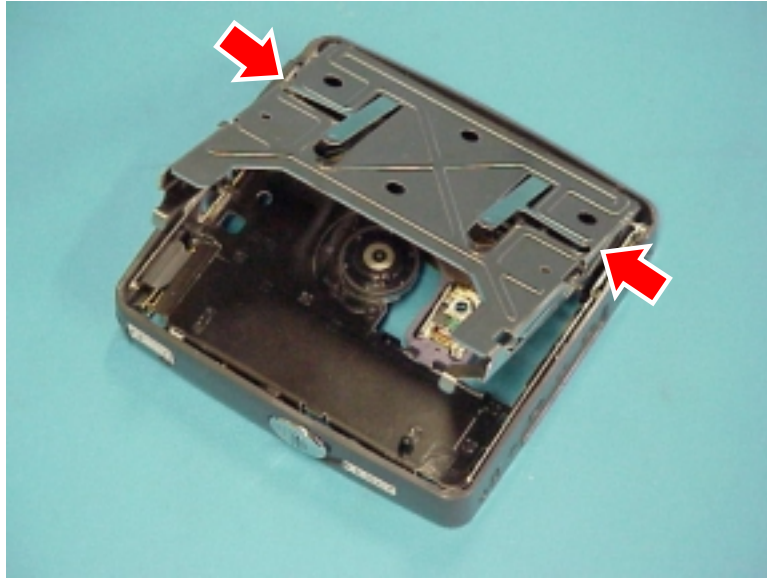

#### 5. Removing the mechanism and the FRAME , CENTER

(1) Remove the two screws "a" and remove the screw "b".

(2) To remove the positioning hole "c" of the mechanism from the FRAME, CENTER, loosen the FRAME, CENTER in the direction of the arrow and remove the mechanism.

\* When attaching them, adjust the position of the HP JACK.

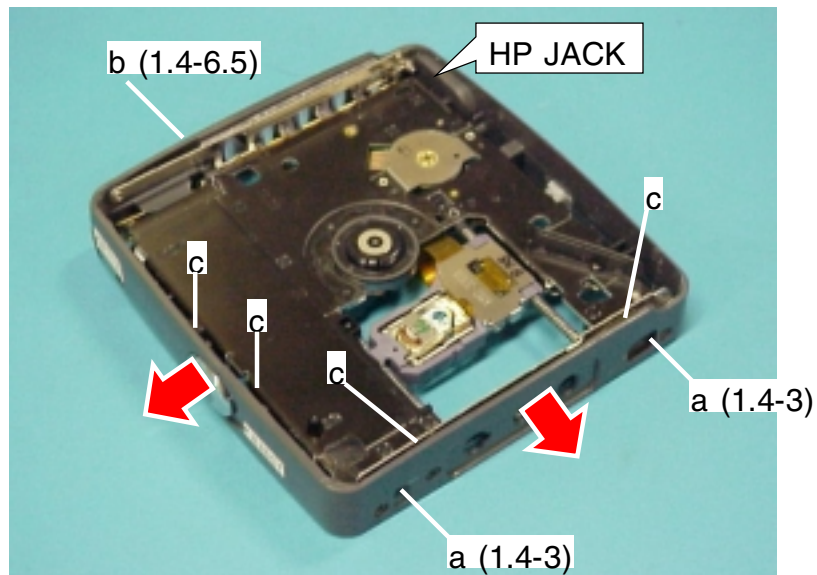

## 6. Removing the PICK-UP

- (1) Remove the poly washer and remove the GEAR, A.
- (2) Remove the screw "a" and remove the SPR-P, LEAD.
- (3) Remove the shaft and the PICK-UP.

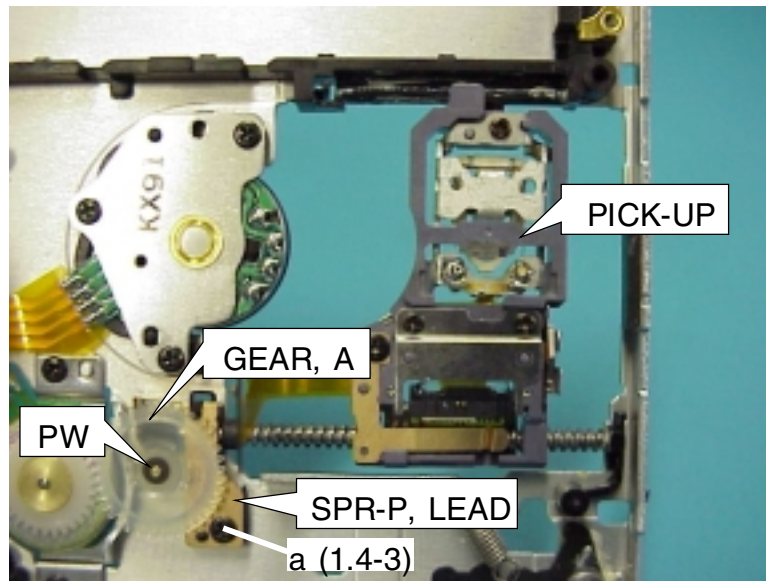

## 7. Removing the SLD, MOTOR

- (1) Remove the poly washer and remove the GEAR, A.
- (2) Remove soldering "a"
- (3) Remove the two screws and remove the SLED MOTOR.

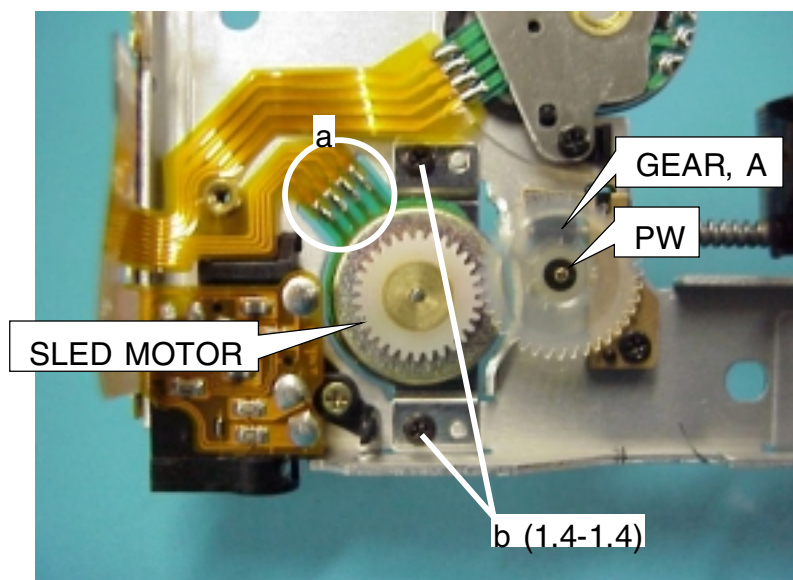

## 8. Removing the SLED MOTOR.

(1) Remove soldering “a”.

(2) Remove the screws “b1”, “b2” and “b3” and remove the SPINDLE MOTOR.

\* To attach the SPINDLE MOTOR, slide it in the direction of the arrow and tighten the screws in order of “b1”, “b2” and “b3”.

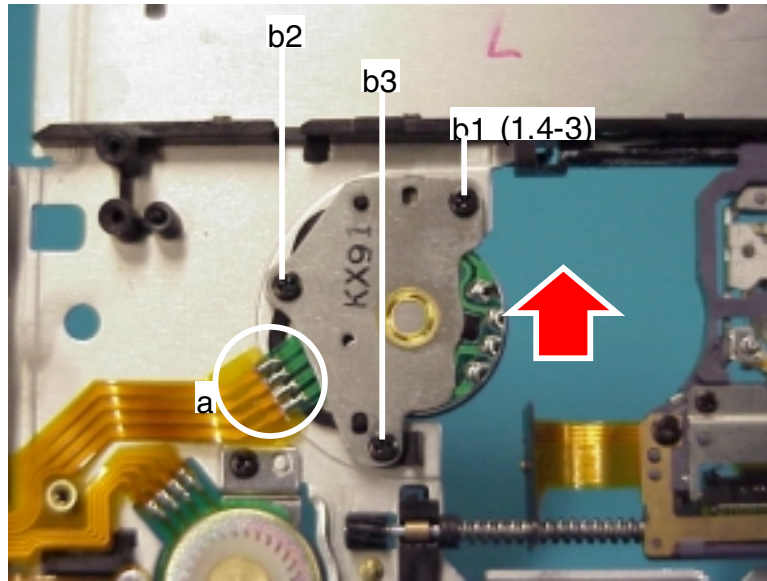



# ELECTRICAL MAIN PARTS LIST

REF. NO.	PART NO.	KANRI NO.	DESCRIPTION	REF. NO.	PART NO.	KANRI NO.	DESCRIPTION
<b>IC</b>				C215	87-A10-535-080	0E	C-CAP,V 22P-50 J CH
	87-A21-294-010	1H	C-IC,LA9606	C216	87-A10-770-080	0E	C-CAP,V 0.1-10 K B
	87-A20-718-040	--	C-IC,TC7S66FU	C217	87-A11-049-080	0E	C-CAP,U 1-6.3 K B
	87-A21-574-010	2Y	C-IC,LC89642	C300	87-A11-049-080	0E	C-CAP,U 1-6.3 K B
	87-A21-526-010	2P	C-IC,GM71VLS17403CTL-1	C301	87-A10-561-080	0E	C-CAP,V 0.01-16 K B
	87-017-861-040	1B	C-IC,TC7W74FU	C302	87-A10-561-080	0E	C-CAP,V 0.01-16 K B
	87-A21-618-040	2P	C-IC,TK70006S	C303	87-A10-561-080	0E	C-CAP,V 0.01-16 K B
	8A-HM6-602-010	1B	C-IC,LC87F5164 (A)	C304	87-A10-561-080	0E	C-CAP,V 0.01-16 K B
	87-A21-030-040	1B	C-IC,S-93C46AMFN	C305	87-A11-050-080	0E	C-CAP,TN 47U-4 M F95 A
	87-A21-038-040	2P	C-IC,NJU7014R-TE2	C307	87-A10-770-080	0E	C-CAP,V 0.1-10 K B
	87-A21-575-010	1B	C-IC,BD6606KVT	C308	87-A10-770-080	0E	C-CAP,V 0.1-10 K B
	87-A21-316-080	1B	C-IC,S-8328B24MC	C309	87-A10-770-080	0E	C-CAP,V 0.1-10 K B
	87-A20-861-040	1A	C-IC,S-80808ANNP	C310	87-012-274-080	0E	C-CAP,U 1000P-50 K B
	87-A20-982-040	1A	C-IC,S-80822ANNP	C400	87-A11-049-080	0E	C-CAP,U 1-6.3 K B
	87-A21-627-040	1B	C-IC,XC6367B102MR	C401	87-A11-049-080	0E	C-CAP,U 1-6.3 K B
	87-A21-341-040	1D	C-IC,TA2131FL	C402	87-A10-556-080	0E	C-CAP,V 2200P-50 K B
<b>TRANSISTOR</b>				C403	87-A10-556-080	0E	C-CAP,V 2200P-50 K B
	87-A30-033-080	0E	C-FET,2SK2035	C404	87-A10-556-080	0E	C-CAP,V 2200P-50 K B
	87-A30-149-080	0E	C-FET,2SJ347	C405	87-A10-556-080	0E	C-CAP,V 2200P-50 K B
	89-115-884-080	0E	C-TR,2SA1588Y	C406	87-A10-556-080	0E	C-CAP,V 2200P-50 K B
	87-A30-181-040	0E	C-TR,DTA114TEA	C407	87-A10-556-080	0E	C-CAP,V 2200P-50 K B
	87-A30-180-040	0E	C-TR,DTC114TEA	C408	87-A11-049-080	0E	C-CAP,U 1-6.3 K B
	87-A30-261-080	1B	C-FET,FDC633N	C409	87-A10-765-080	0E	C-CAP,U 0.033-10 K B
	87-A30-262-080	1B	C-FET,FDC634P	C410	87-A10-765-080	0E	C-CAP,V 0.033-10 K B
	89-332-654-080	0E	C-TR,2SC3265Y	C411	87-A10-770-080	0E	C-CAP,V 0.1-10 K B
	87-A30-147-080	0E	C-TR,2SA1832GR	C412	87-A10-770-080	0E	C-CAP,V 0.1-10 K B
	87-A30-499-040	--	C-FET,2SK2009	C413	87-A10-770-080	0E	C-CAP,V 0.1-10 K B
<b>DIODE</b>				C414	87-A11-050-080	--	C-CAP,TN 47U-4 M F95 A
	87-017-850-080	0E	C-DIODE,DAP222	C415	87-A11-046-080	1B	C-CAP,TN 100U-4 M F95 B
	87-A40-687-080	0E	C-DIODE,M1FH3	C416	87-A11-751-080	0E	C-CAP,TN 22U-4 M P
<b>MAIN C.B</b>				C417	87-A11-807-080	0E	C-CAP,TN 4.7U-6.3 M P
C101	87-A10-770-080	0E	C-CAP,V 0.1-10 K B	C600	87-A11-806-080	0E	C-CAP,TN 47U-6.3 M PSLB
C102	87-A10-765-080	0E	C-CAP,V 0.033-10 K B	C601	87-A10-557-080	0E	C-CAP,V 3300P-25 K B
C103	87-A10-766-080	0E	C-CAP,V 0.047-10 K B	C602	87-A11-806-080	1B	C-CAP,TN 47U-6.3 M PSLB
C104	87-A10-765-080	0E	C-CAP,V 0.033-10 K B	C603	87-A10-770-080	0E	C-CAP,V 0.1-10 K B
C105	87-A10-765-080	0E	C-CAP,V 0.033-10 K B	C604	87-A10-770-080	0E	C-CAP,V 0.1-10 K B
C106	87-A10-765-080	0E	C-CAP,V 0.033-10 K B	C606	87-A11-807-080	0E	C-CAP,TN 4.7U-6.3 M P
C107	87-A10-765-080	0E	C-CAP,V 0.033-10 K B	C607	87-A11-049-080	0E	C-CAP,U 1-6.3 K B
C108	87-A10-531-080	0E	C-CAP,V 10P-50 D CH	C608	87-A11-751-080	1A	C-CAP,TN 22U-4 M P
C109	87-A10-523-080	0E	C-CAP,V 2.0P-50 C CK	C609	87-A10-561-080	0E	C-CAP,V 0.01-16 K B
C110	87-A11-058-080	0E	C-CAP,U 0.22-10 K B	C610	87-A10-550-080	0E	C-CAP,V 470P-50 K B
C111	87-A10-561-080	0E	C-CAP,V 0.01-16 K B	C611	87-A11-049-080	0E	C-CAP,U 1-6.3 K B
C112	87-A10-561-080	0E	C-CAP,V 0.01-16 K B	C612	87-A10-561-080	0E	C-CAP,V 0.01-16 K B
C114	87-A10-770-080	0E	C-CAP,V 0.1-10 K B	C613	87-A11-049-080	0E	C-CAP,U 1-6.3 K B
C115	87-A10-556-080	0E	C-CAP,V 2200P-50 K B	C700	87-A11-751-080	1A	C-CAP,TN 22U-4 M P
C116	87-A11-049-080	0E	C-CAP,U 1-6.3 K B	C701	87-A10-770-080	0E	C-CAP,V 0.1-10 K B
C117	87-A11-751-080	1A	C-CAP,TN 22U-4 M P	C702	87-A10-543-080	0E	C-CAP,V 100P-50 J CH
C118	87-A11-050-080	1A	C-CAP,TN 47U-4 M F95 A	C703	87-A10-543-080	0E	C-CAP,V 100P-50 J CH
C119	87-A10-826-080	1A	C-CAP,S 1-10 K B	C704	87-A10-543-080	0E	C-CAP,V 100P-50 J CH
C120	87-A10-770-080	0E	C-CAP,V 0.1-10 K B	C705	87-A10-543-080	0E	C-CAP,V 100P-50 J CH
C121	87-A11-751-080	1A	C-CAP,TN 22U-4 M P	C706	87-A11-049-080	0E	C-CAP,U 1-6.3 K B
C122	87-A10-561-080	0E	C-CAP,V 0.01-16 K B	C707	87-016-449-080	1A	C-CAP,TN 10-4 M S
C123	87-A10-554-080	0E	C-CAP,V 1000P-50 K B	C708	87-016-449-080	1A	C-CAP,TN 10-4 M S
C124	87-A10-554-080	0E	C-CAP,V 1000P-50 K B	C709	87-A11-058-080	0E	C-CAP,U 0.22-10 K B
C200	87-016-669-080	0E	C-CAP,S 0.1-25 K B	C710	87-A11-058-080	0E	C-CAP,U 0.22-10 K B
C201	87-A11-050-080	1A	C-CAP,TN 47U-4 M F95 A	C711	87-A11-049-080	0E	C-CAP,U 1-6.3 K B
C202	87-A10-770-080	0E	C-CAP,V 0.1-10 K B	C712	87-A11-049-080	0E	C-CAP,U 1-6.3 K B
C203	87-A10-556-080	0E	C-CAP,V 2200P-50 K B	C713	87-A11-751-080	1A	C-CAP,TN 22U-4 M P
C204	87-A10-671-080	0E	C-CAP,V 0.022-16 K B	C715	87-A11-318-080	1B	C-CAP,TN 220U-2.5 SVB2
C206	87-A10-770-080	0E	C-CAP,V 0.1-10 K B	C716	87-A11-318-080	1B	C-CAP,TN 220U-2.5 SVB2
C208	87-A10-770-080	0E	C-CAP,V 0.1-10 K B	C717	87-A11-049-080	0E	C-CAP,U 1-6.3 K B
C209	87-A10-770-080	0E	C-CAP,V 0.1-10 K B	C719	87-A11-049-080	0E	C-CAP,U 1-6.3 K B
C212	87-A11-751-080	1A	C-CAP,TN 22U-4 M P	C720	87-A11-058-080	0E	C-CAP,U 0.22-10 K B
C214	87-A10-535-080	0E	C-CAP,V 22P-50 J CH	C800	87-012-274-080	0E	C-CAP,U 1000P-50 K B
				CN100	87-A61-276-080	1B	C-CONN,20P H 545482090
				CN300	87-A61-020-080	1A	C-CONN,4P H 54550-0417
				CN700	87-A60-954-080	1B	C-CONN,16P H 54548-1611
				D300	87-A40-556-080	0E	C-LED,CL-270HR RED
				L100	87-A50-360-080	0E	C-COIL, 47UH K NLFPC252018
				L101	87-003-245-080	0E	C-COIL,2125 22UH K MLF2012

REF. NO.	PART NO.	KANRI NO.	DESCRIPTION	REF. NO.	PART NO.	KANRI NO.	DESCRIPTION
L200	87-003-245-080	0E	C-COIL,2125 22UH K MLF2012	R702	87-A50-208-080	0E	C-COIL,BLM11A601SPT
L300	87-005-769-080	0E	C-COIL,2125 100UH K MLF2012	S300	87-A91-436-080	1A	C-SW,PUSH 2-1-1 SPVE3.8
L400	87-A50-475-080	0E	C-COIL, 10UH K NLFC201614	S301	87-A90-703-080	0E	C-SW,SL 1-1-3 SSSS813-B-2B
L401	87-A50-475-080	0E	C-COIL, 10UH K NLFC201614	X200	87-A70-207-080	1B	C-VIB,16.9344MHZ SSR-B
L402	87-A50-475-080	0E	C-COIL, 10UH K NLFC201614	X300	87-A70-212-080	1B	C-VIB,3.00MHZ PBRC-B
L403	87-A50-475-080	0E	C-COIL, 10UH K NLFC201614				
L404	87-A50-537-080	0E	C-COIL, 100UH C4-K3L				
L405	87-A50-011-080	0E	C-COIL, 47UH LQH3C				
L406	87-003-245-080	0E	C-COIL,2125 22UH K MLF2012				
L600	87-A50-537-080	1A	C-COIL, 100UH C4-K3L				
L601	87-A50-012-080	0E	C-COIL, 100UH LQH3C				
L701	87-005-769-080	1A	C-COIL,2125 100UH K MLF2012				
L702	87-A50-233-080	1A	C-COIL,ACM4532-102-3P				
PR600	87-A91-769-080	1A	C-PROTECTOR,0.75A ERY32SB075				
PR601	87-A91-769-080	1A	C-PROTECTOR,0.75A ERY32SB075				
R305	87-022-239-080	0E	C-RES,U 10K-1/16W F				
R306	87-022-249-080	0E	C-RES,U 27K-1/16W F				
R615	87-A00-722-080	0E	C-RES,V 33K-1/16W F				
R616	87-A00-723-080	0E	C-RES,V 56K-1/16W F				
R701	87-A50-208-080	0E	C-COIL,BLM11A601SPT				



○チップ抵抗部品コード／CHIP RESISTOR PART CODE

チップ抵抗部品コードの成り立ち

Chip Resistor Part Coding

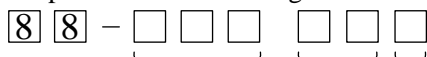

A  
抵抗部品コード  
Resistor Code

桁表示  
Figure

抵抗値  
Value of resistor

チップ抵抗  
Chip resistor

容量 Wattage	種類 Type	許容誤差 Tolerance	記号 Symbol	寸法/Dimensions (mm)			抵抗コード : A Resistor Code : A	
				外形/Form	L	W		t
1/16W	1005	± 5%	CJ		1.0	0.5	0.35	104
1/16W	1608	± 5%	CJ		1.6	0.8	0.45	108
1/10W	2125	± 5%	CJ		2	1.25	0.45	118
1/8W	3216	± 5%	CJ		3.2	1.6	0.55	128

# TRANSISTOR ILLUSTRATION

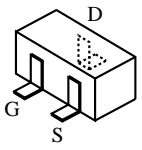

2SJ347  
2SK2009  
2SK2035

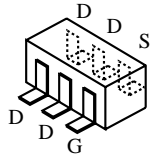

FDC633N  
FDC634P

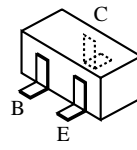

2SA1588  
2SA1832  
2SC3265  
DTA114TEA  
DTC114TEA

32 31 30 29 28 27 26 25 24 23 22 21 20 19 18 17 16 15 14 13 12 11 10 9 8 7 6 5 4 3 2 1

# A MAIN C.B (COMPONENT SIDE)

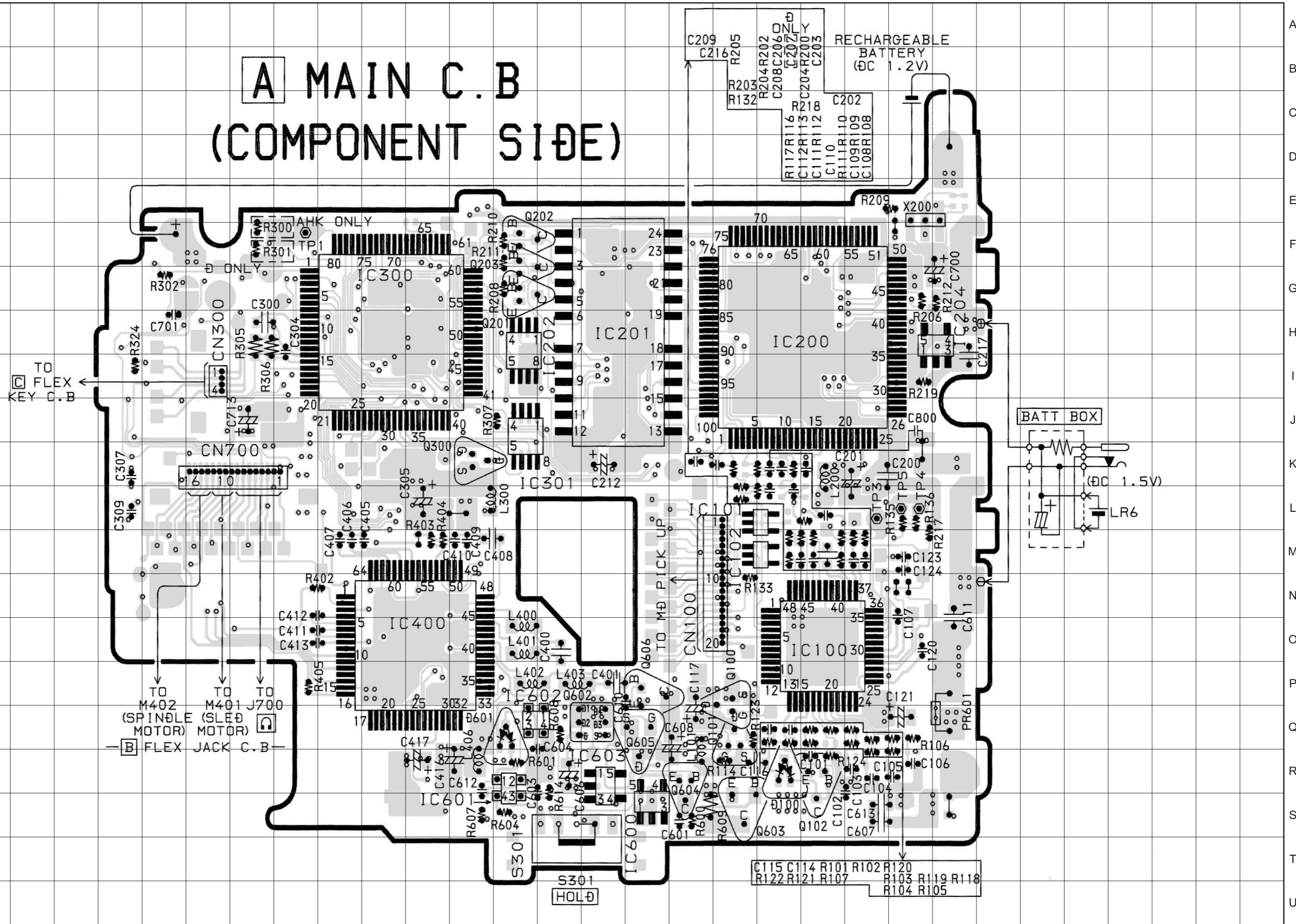

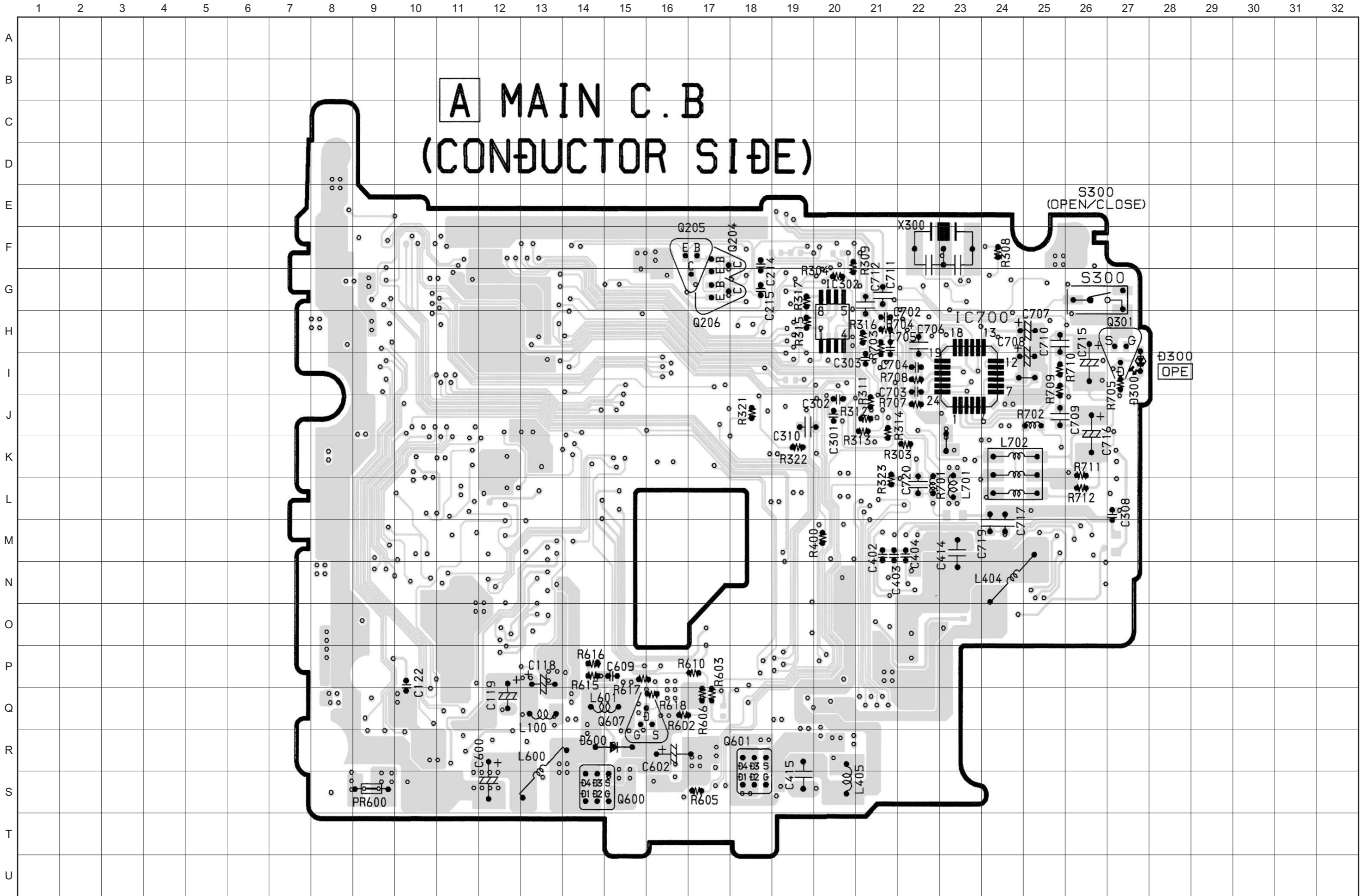

SCHEMATIC DIAGRAM -1 (MAIN)

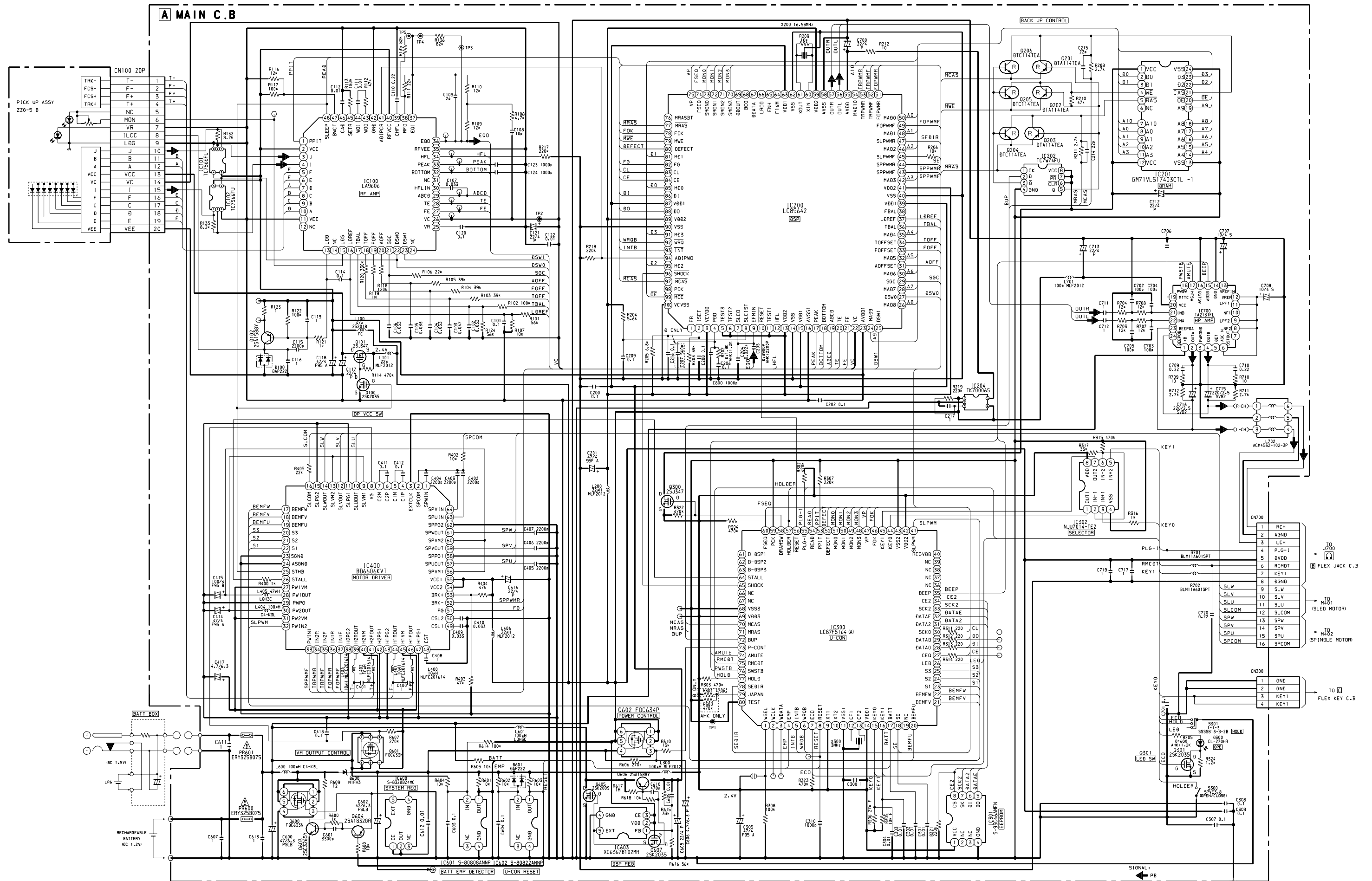

WIRING - 2 (FLEX JACK / FLEX KEY)

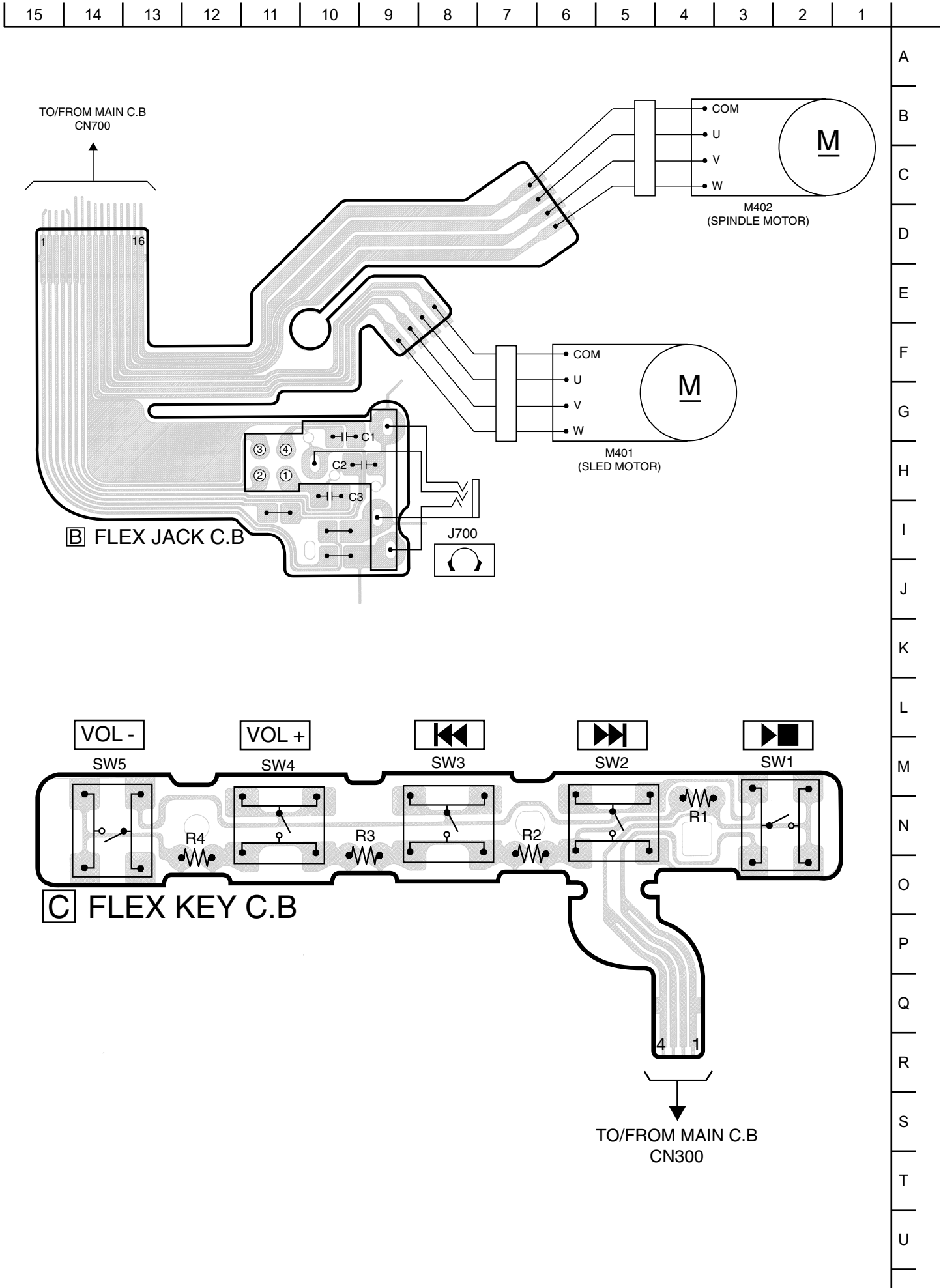

# IC BLOCK DIAGRAM

IC, NJU7014R-TE2

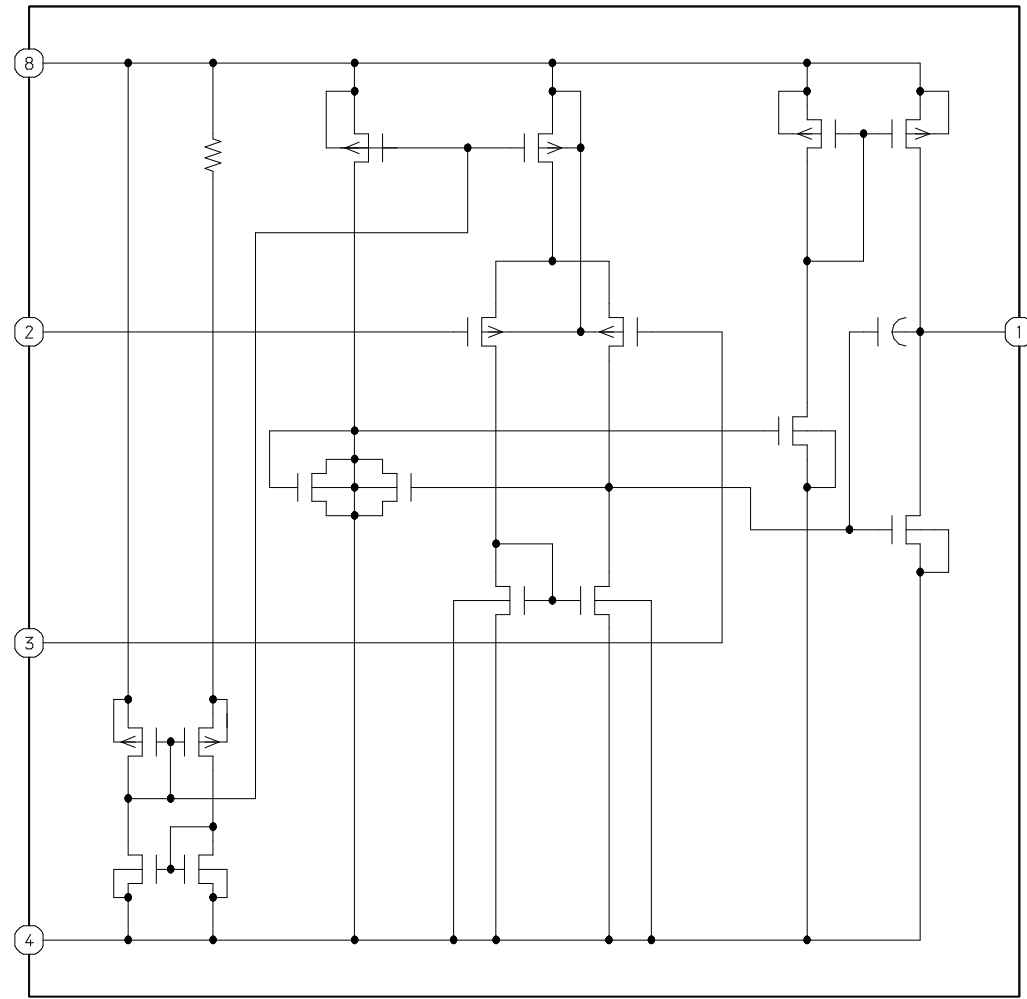

IC, TA2131FL

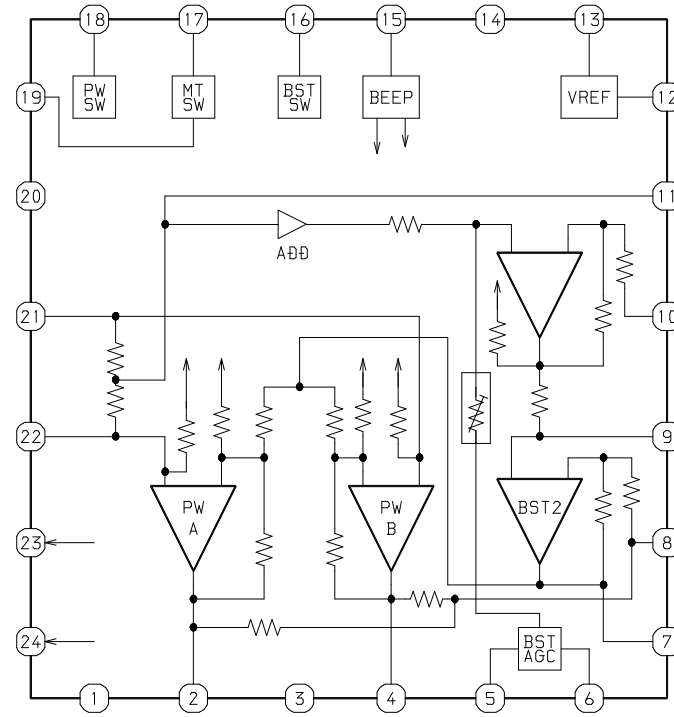

IC, TC7S66FU

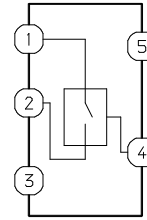

TRUTH TABLE

CONTROL	SWITCH FUNCTION
H	ON
L	OFF

IC, TC7W74FU

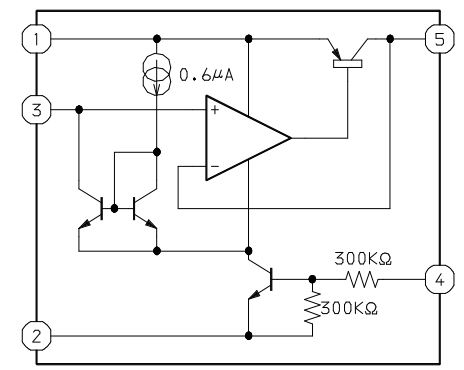

IC, S-8080ANNP

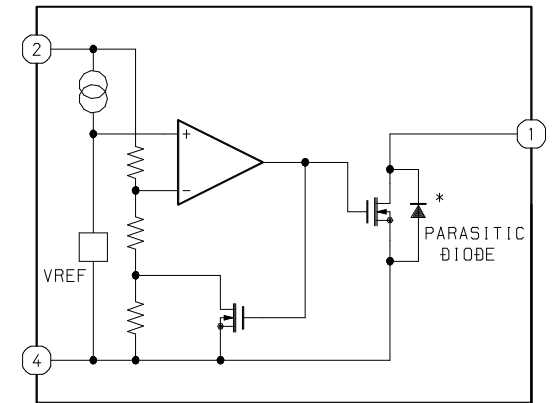

IC, XC6367B102MR

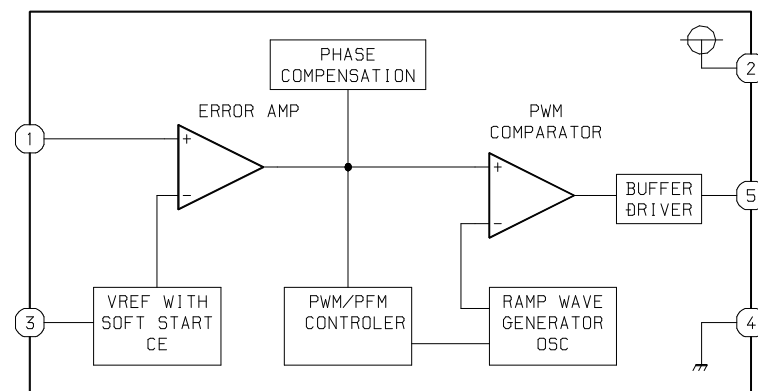

IC, S-80822ANNP

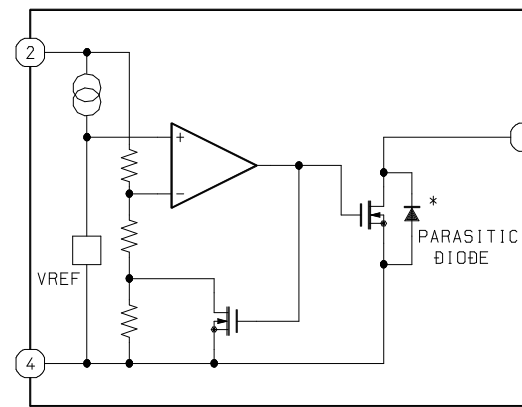

IC, TC7W74FU

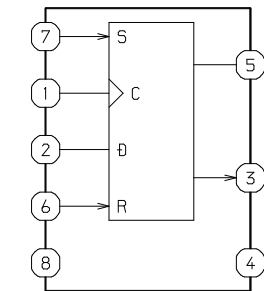



# IC DESCRIPTION

IC, LC875164A

Pin No.	Pin Name	I/O	Description
1	WSEL	O	Select signal terminal for writing flash memory (Normally L output).
2	WCLK	O	CLOCK terminal for writing flash memory (Normally L output).
3	WDATA	O	DATA I/O terminal for writing flash memory (Normally L output).
4	EMP	I	Electricity reduction interrupt input.
5	INTB	I	Interrupt request input from L89642.
6	WRQB	I	Interrupt request input from L89642.
7	ECO	I	ECO input terminal.
8	RESET	I	Micom reset.
9	XT1	–	Connect to VDD.
10	XT2	–	Not used (L Output).
11	VSS1	–	Connect to GND.
12, 13	CF1, CF2	–	3[MHz] clock.
14	VDD1	–	Connect to VDD.
15	KEY0	I	Main unit KEY A/D input.
16	KEY1	I	Remote control KEY input.
17	BATT	I	Battery voltage A/D input.
18	SE	I	Sledding drive voltage A/D input.
19	NC	O	Not used (L Output).
20	BEMFU	I	Motor driver's comparator output.
21	BEMFV	I	
22	BEMFW	I	
23~25	S1~S3	O	Sledding control output.
26	LED	O	Operation LED control signal output (LED ON with H).
27	CE0	O	Chip select signal of LC89642.
28	DATA0	O	Serial data output to LC89642.
29	DATAD	I	Serial data input from LC89642.
30	SCLK0	O	Serial clock output to LC89642.
31	DATA2	O	Serial data output to EEPROM.
32	DATAE	I	Serial data input from EEPROM.
33	SCLK2	O	Serial clock output to EEPROM.
34	CE2	O	Chip select signal output of EEPROM.
35	BEEP	O	BEEP signal output.
36~40	NC	O	Not used (L Output).
41	SLPWM	O	PWM output for VM control of motor driver.
42	VDD2	–	Connect to VDD.
43	VSS2	–	Connect to GND.
44	KEY0	I	Standby cancel signal input by the main unit KEY.
45	KEY1	I	Standby cancel signal input by remote control KEY.
46	FOK	I	FOK signal input
47	VP	I	VP (CLV servo lock check) signal input.
48	MON3	I	Monitor 3 signal input from LC89642.
49	MON2	I	Monitor 2 signal input from LC89642.

Pin No.	Pin Name	I/O	Description
50	MON1	I	Monitor 1 signal input from LC89642.
51	MON0	I	Monitor 0 signal input from LC89642.
52	DEFECT	I	DEFECT signal input.
53	PPIT	I	PPIT signal input.
54	READ	O	Output H when reading data.
55	PLG-1	I	Insertion detection signal input of head phone jack (L: Inserted).
56	RESET	O	LC89642 reset signal output.
57	HOLDER	I	Holder OPEN(H)/CLOSE (L) signal input & standby release.
58	DRAMSW	O	Power supply control output of DRAM L: (Turn on the power supply of DRAM).
59	PCK	I	PCK signal input of LC89642.
60	FSEQ	I	FSEQ signal input of LC89642.
61~63	NC	O	Not used (L Output).
64	STALL	O	Power supply control output of BD6606 (H: ON).
65	SHOCK	I	SHOCK input of LC89642
66,67	NC	O	Not used (L Output).
68	VSS3	–	Connect to GND.
69	VDD3	–	Connect to VDD.
70	MCAS	O	CAS signal output to DRAM.
71	MRAS	O	RAS signal output to DRAM.
72	BUP	O	Micom control of DRAM/DSP control switch signal output (H: Micom control).
73	P-CON	O	System power supply control (L: Turn on the power supply).
74	AMUTE	O	AUDIO MUTE signal output (H: Turn ON MUTE).
75	RMCDT	O	Serial data output to liquid crystal remote controller.
76	PWSTB	O	Standby signal output of headphone driver (L: standby).
77	HOLD	I	HOLD signal input (L: HOLD ON)
78	SEDIR	I	Direction input of sledding move (H: inside → outside, L: outside → inside).
79	JAPAN	I	Domestic / Overseas version switch input (H: Domestic).
80	TEST	I	Test mode / Main mode switch input (L: Test mode).

Pin No.	Pin Name	I/O	Description
1	FR	I	Bias resistance terminal of VCEC oscillation frequency.
2	ISET	I	Bias resistance terminal of VCEC electric current charging pump.
3	VCVDD	–	Power supply terminal for VCEC.
4	PDO	O	Electric current charging pump output terminal of VCEC.
5	TEST3	I	Test input terminal.
6	TEST2	I	Test input terminal.
7	SLCO	O	Slice level output terminal of HF signal.
8	SLCIST	I	Bias resistance terminal of slice level adjustment amplifier.
9	EFMIN	I	HF signal input terminal.
10	$\overline{\text{RESET}}$	I	System Reset.
11	TEST1	I	Test input terminal.
12	HFL	I	Track detection signal input terminal.
13	VDD2	–	Power supply terminal.
14	VSS	–	Ground terminal.
15	VDD1	–	Internal power supply terminal.
16	AVSS1	–	Ground terminal for digital servo.
17	PEAK	I	PEAK signal input terminal.
18	BOTTOM	I	BOTTOM signal input terminal.
19	ABCD	I	Main beam light amount signal input terminal.
20	TE	I	Tracking error signal input.
21	FE	I	Focus error signal input terminal.
22	VC	I	Intermediate electric potential input terminal.
23	AVDD1	–	Power supply terminal for digital servo.
24	MAD9	O	Address output terminal to DRAM (Not connected).
25	DSW1	O	Disc mode switch output.
26	MAD8	O	Address output terminal to DRAM (Not connected).
27	DSW0	O	Disc mode switch output.
28	MAD7	O	Address output terminal to DRAM (Not connected).
29	SGC	O	AGC control signal output terminal.
30	MAD6	O	Address output terminal to DRAM (Not connected).
31	AOFFSET	O	ABCD offset control signal output terminal.
32	MAD5	O	Address output terminal to DRAM (Not connected).
33	FOFFSET	O	Focus offset control signal output terminal.
34	TOFFSET	O	Tracking offset control signal output terminal.
35	MAD4	O	Address output signal to DRAM (Not connected).
36	TBAL	O	Tracking balance control signal output terminal.
37	LDREF	O	Laser control signal output.
38	FBAL	O	Focus balance control signal output.
39	VDD1	–	Internal power supply.
40	VSS	–	GND.
41	VDD2	–	Power supply.
42	MAD3	–	DRAM address output.

Pin No.	Pin Name	I/O	Description
43	SPPWMF	O	Spindle PWM output.
44	SPPWMR	O	Spindle PWM output.
45	SLPWMF	O	Sled PWM output.
46	MAD2	O	DRAM address output.
47	SLPWMR	O	Sled PWM output.
48	MAD1	O	DRAM address output.
49	FOPWMF	O	Focus PWM output.
50	MAD0	O	DRAM address output.
51	FOPWMR	O	Focus PWM output.
52	TRPWMF	O	Tracking PWM output.
53	TRPWMR	O	Tracking PWM output.
54	MAD10	O	DRAM address output.
55	AVDD	-	1bit D/C converter power supply.
56	OUTL	O	1bit D/C converter left channel output.
57	OUTR	O	1bit D/C converter Right channel output.
58	AVSS	O	1bit D/C converter ground.
59	VDD2	-	Power supply.
60	XIN	I	16.9344MHz oscillator circuit input.
61	XOUT	O	16.9344MHz oscillator circuit input.
62	VSS	-	GND.
63	VDD1	-	Power supply.
64	F16M	I	16.9344MHz circuit input.
65	ENH	O	De-emphasis indicator output.
66	LRCO	O	LR clock output.
67	DDATA	O	Expanded audio data output.
68	BCO	O	Bit clock output.
69	DDOUT	O	Digital audio output.
70	SMON3	O	Monitor signal output.
71	SMON2	O	Monitor signal output.
72	SMON1	O	Monitor signal output.
73	SMON0	O	Monitor signal output.
74	FSEQ	O	Frame period detection signal output.
75	VP	O	CLV servo lock recognition output.
76	MRASBT	O	Test output terminal.
77	$\overline{\text{MRAS}}$	O	$\overline{\text{RAS}}$ signal output terminal to DRAM (Not connected).
78	FOK	O	Focus OK signal output terminal.
79	$\overline{\text{MWE}}$	O	$\overline{\text{WE}}$ signal output terminal to DRAM (Not connected).
80	DEFECT	O	Defect signal input and output terminal.
81	MD1	I/O	Data input and output terminal to DRAM (Not connected).
82	FG	I	Speed pulse input terminal.
83	CL	I	Data transfer clock input terminal for CPU interface.
84	CE	I	Chip enable signal input terminal for CPU interface.

Pin No.	Pin Name	I/O	Description
85	MD0	I/O	Data input and output signal output terminal to DRAM (Not connected).
86	DI	I	Data input terminal for CPU interface.
87	VDD1	–	Internal power supply terminal.
88	DO	O	Data output terminal for CPU interface.
89	VDD2	–	Power supply terminal.
90	VSS	–	Ground terminal.
91	MD3	I/O	Data input and output signal output terminal to DRAM (Not connected).
92	$\overline{\text{WRQ}}$	O	Interrupt signal output terminal for CPU interface.
93	$\overline{\text{INT}}$	O	Interrupt signal output terminal for CPU interface.
94	ADIPWO	I	Wobble signal input terminal.
95	MD2	I/O	Data input and output signal output terminal to DRAM (Not connected).
96	SHOCK	O	SHOCK / RFNG output terminal.
97	$\overline{\text{MCAS}}$	O	$\overline{\text{CAS}}$ signal output terminal to DRAM (Not connected).
98	PCK	O	VCEC system clock signal output terminal.
99	$\overline{\text{MOE}}$	O	$\overline{\text{OE}}$ signal output terminal to DRAM (Not connected).
100	VCVSS	–	Ground terminal for VCEC.

## IC, BD6606KVT

Pin No.	Pin Name	I/O	Description
1	SPWIN	I	SPIN detection comparator input (Phase W).
2	SPCOM	I	SPIN motor coil mid-point input terminal.
3	EXTCLK	I	Synchronized clock input terminal.
4	C1P	-	CHARGE PUMP capacitor 1 connect terminal +.
5	C1M	-	CHARGE PUMP capacitor 1 connect terminal -.
6	C2P	-	CHARGE PUMP capacitor 2 connect terminal +.
7	C2M	-	CHARGE PUMP capacitor 2 connect terminal -.
8	VG	O	CHARGE PUMP output.
9	SLVM1	-	Stepping power part power supply 1.
10	SLUOUT	O	Stepping motor output (Phase U).
11	SLPG1	-	Stepping power part GND 1.
12	SLVOUT	O	Stepping motor output (Phase V).
13	SLVM2	-	Stepping power part power supply 2.
14	SLWOUT	O	Stepping motor output (Phase W).
15	SLPG2	-	Stepping power part GND 2.
16	SLCOM	I	STEP motor coil mid-point input terminal.
17	BEMFW	O	STEP detection comparator output (Phase W).
18	BEMFV	O	STEP detection comparator output (Phase V).
19	BEMFU	O	STEP detection comparator output (Phase U).
20	S3	I	Stepping decoder input 3.
21	S2	I	Stepping decoder input 2.
22	S1	I	Stepping decoder input 1.
23	SGND	-	Small signal part GND (MOS).
24	ASGND	-	Small signal part GND (Bip.).
25	STHB	O	H1 and H2 bridge mute terminal.
26	STALL	I	Standby terminal.
27	PW1VM	-	Half bridge 1 power part power supply.
28	PW1OUT	O	Half bridge 1 output.
29	PWPG	-	Half bridge power part GND.
30	PW2VOUT	-	Half bridge 2 output.
31	PW2VM	-	Half bridge 2 power part power supply.
32	PWIN2	I	Half bridge 2 input.
33	PWIN1	I	Half bridge 1 input.
34	IN2R	I	H bridge 2 reverse input.
35	IN2F	I	H bridge 2 forward input.
36	IN1R	I	H bridge 1 reverse input.
37	IN1F	I	H bridge 1 forward input.
38	H2PG2	-	H bridge 2 power part GND2.
39	H2ROUT	O	H bridge 2 reverse output.
40	H2VM	-	H bridge 2 power part power supply.
41	H2FOUT	O	H bridge 2 forward output.
42	H2PG1	-	H bridge 2 power part GND1.

Pin No.	Pin Name	I/O	Description
43	H1PG2	–	H bridge 1 power part GND2.
44	H1ROUT	O	H bridge 1 reverse output.
45	H1VM	–	H bridge 1 power part power supply.
46	H1FOUT	O	H bridge 1 forward output.
47	H1PG1	–	H bridge 1 power part GND1.
48	CST	–	Start oscillation capacitor connection terminal.
49	CSL1	–	Slope capacitor connection terminal 1.
50	CSL2	–	Slope capacitor connection terminal 2.
51	FG	O	FG output.
52	BRK-	I	Break comparator input (-).
53	BRK+	I	Break comparator input (+).
54	VCC2	–	Small signal part power supply terminal 2(Bip.).
55	VCC1	–	Small signal part power supply terminal 1(MOS).
56	SPVM1	–	Spindle power part power supply 1.
57	SPUOUT	O	Spindle motor output (Phase U).
58	SPPG1	–	Spindle power part GND 1.
59	SPVOUT	O	Spindle motor output (Phase V).
60	SPVM2	–	Spindle power part power supply 2.
61	SPWOUT	O	Spindle motor output (Phase W).
62	SPPG2	–	Spindle power part GND 2.
63	SPUIN	I	SPIN detection comparator input (Phase U).
64	SPVIN	I	SPIN detection comparator input (Phase V).

Pin No.	Pin Name	I/O	Description
1	PPIT	O	Pit / Group identification signal output. Hi=pit, Lo=group
2	VCC	--	Power supply pin of Matrix system.
3	J	I	Photo diode connection pin of pickup. Form RF signal with I pin.
4	I	I	Photo diode connection pin of pickup. Form RF signal with J pin.
5	F	I	Photo diode connection pin of pickup. Form TE signal with E pin.
6	E	I	Photo diode connection pin of pickup. Form TE signal with F pin.
7	D	I	Photo diode connection pin of pickup. It forms FE signal, ABCD signal, and WOO signal
8	C	I	
9	B	I	
10	A	I	
11	VEE	-	Ground pin of Matrix system.
12	NC	-	Not used.
13	LDD	O	APC circuit output pin.
14	NC	-	Not used.
15	LDS	I	APC circuit input pin.
16	LDREF	I	Input pin for laser power setting.
17	TBAL	I	EF balance adjustment pin.
18	TOFF	I	Offset adjustment pin of TE signal.
19	FOFF	I	Offset adjustment pin of FE signal.
20	AOFF	I	Offset adjustment pin of ABCD signal.
21	SGC	I	VCA gain control pin.
22	DSW0	I	Disc mode setting pin. Hi = Disc with low reflectance, Lo = Disc with high reflectance. Laser OFF when DSW0 and DSW1 are in Lo.
23	DSW1	I	Disc mode setting pin. Hi = Track in pin line, Lo = Track in group. Laser OFF when DSW0 and DSW1 are in Lo.
24	NC	-	Not used.
25	VR	-	Pass-con connection pin for 1/2VCC.
26	VC	O	1/2VCC output pin.
27	FE	O	Focus error signal output pin.
28	TE	O	Tracking error signal output pin.
29	ABCD	O	Main beam light amount signal output pin.
30	HFLIN	I	HEL signal forming pin in group mode.
31	NC	-	Not used.
32	BOTTOM	O	Bottom signal output pin of RF signal.
33	PEAK	O	Peak signal output pin of RF signal.
34	HFL	O	HFL signal (Track ON/OFF) output pin
35	RFVEE	-	Ground pin of RF system
36	EQO	O	RF equalizer output pin.
37	EQI	I	RF equalizer input pin.
38	RFO	O	RF signal output pin.
39	CHFL	-	Capacitor connection pin for bottom hold.
40	RFVCC	-	Power supply pin of RF system.



Pin No.	Pin Name	I/O	Description
41	ADIPCR	O	ADIP carrier signal output pin.
42	NC	–	Not used.
43	WOO	O	Wobble signal output pin.
44	WOI	I	Wobble signal input pin.
45	SETR	I	Band pass filter setting pin.
46	CAD	–	Capacitor connection pin of wobble signal for DC cut.
47	BWCT	I	Band pass filter switch pin of wobble signal.
48	SLEEP	I	Sleep mode. SLEEP=Hi: Power ON, SLEEP=Lo: Power OFF.

## TEST MODE

The operations are displayed by LCD of the remote controller.

The keys of the main unit and remote controller can control shifts between operations.

- \* TEST MODE will ignore any abnormalities during operations. Plug off the power supply once any abnormalities are detected.
- \* HOLD switch of the remote controller will function in TEST MODE.

## TEST MODE

### 1. How to activate and cancel Test Mode

#### (1) How to activate

Turn ON the power supply (set batteries) while pressing "VOL-" keys of the both main unit and remote controller.

Once Test Mode is activated, LCD will all light up and EL backlight will be turned ON.

Then it displays "Engineer MODE".

#### (2) How to cancel

Turn OFF the power supply to cancel Test Mode.



LCD Display when Test Mode is activated.

### 2. TEST MODE operations

There are 0~13 Test Modes, which are in the order of playback operations. These modes may be selected using VOL+/- keys, while they can be started or stopped by pressing PLAY key. If a Test Mode is selected, a data will be displayed in "\$XXXX".

- \* The values displayed in "\$XXXX" are just IC internal data and their numerical values are of no significance (except for that of No.0, 13)
- If any abnormalities were detected during the operation, it displays "Failed".



No.	LCD Display		Contents
0	00	050c Xe	ALL SV ON (EEPROM Data)
1	01	VC \$XXXX	VC offset
2	02	ABCD \$XXXX	ABCD input offset
3	03	FE \$XXXX	Focus Error offset
4	04	TE \$XXXX	Tracking Error offset
5	05	FOCUS CHK	Focus search(Focus servo OFF) Spindle Rough Servo
6	06	FOCUS SRCH FOCUS ON!	Focus search, Spindle rough servo Focus servo ON during DISC IN
7	07	Laser \$XX	Laser power adjustment value
8	08	ABCD G \$XX	ABCD AGC
9	09	EF \$XXXX	Traverse adjustment value
10	0A	FG \$XXXX	Focus Gain adjustment value
11	0B	TG \$XXXX	Tracking Gain adjustment value
12	0C	FB \$XXXX	Focus Bias adjustment value
13	0D	050c Xe	ALL SERVO ON(Operate all of 1-12)

(1) Checking Laser Power

The display will repeat the string of OFF-> PIT Laser Power -> GRV Laser Power -> OFF every time DISP/SEARCH key of the remote controller is pressed.

- \* Laser will not be luminescent.
- LCD Display
  - PIT Laser Power "LDPP \$XX"
  - GRV Laser Power "LDPG \$XX"

(2) Checking Sled Operation

Sled operation can be checked between Mode No. 0, 5~12.

Press F-SKIP to shift the pick-up towards the external circumference.

Press B-SKIP to shift the pick-up towards the internal circumference.



(3) Checking Switch Operation

OPEN/CLOSE SW and HOLD SW on a disc holder can be checked on LCD of the remote controller.

- Light up when the disc holder is closed.
- Alarm mark will light up when HOLD SW on the main unit is turned ON. While POWER SAVE is on, "-" will light up. It does not display HOLD SW of the remote controller.

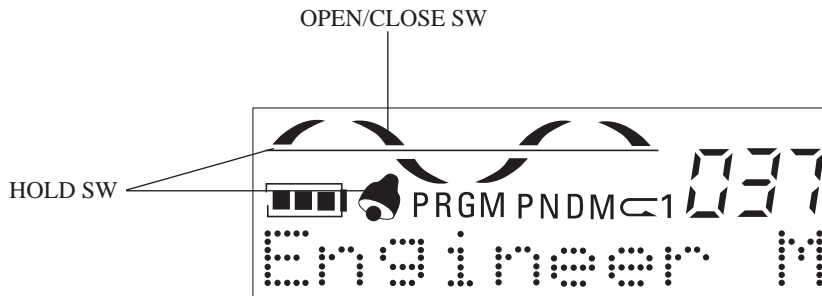

## ADJUSTMENT MODE

### 1. How to activate and cancel Adjustment Mode

Operations in Adjustment Mode can be checked on the LCD of the remote controller.

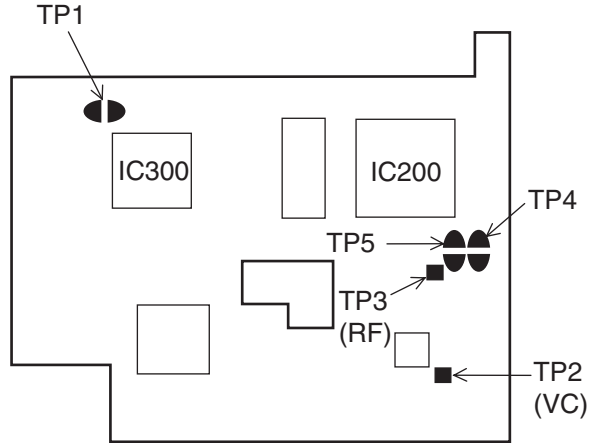

MAIN circuit board Test Points

#### (1) How to activate

Turn ON the power (set batteries) while shorting TP1 of the main circuit board. Once Adjustment Mode is activated, LCD will all light up and EL backlight will be turned ON. Then it displays "Manufacture MODE".



Press "PLAY/STOP" key twice to display "IDLE".

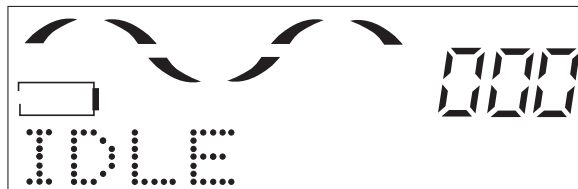

#### (2) How to cancel

Turn OFF the power supply to cancel Adjustment Mode.

#### (3) Disc to be used

PIT disc (pre-mastered disc): TEST DISC (TGYS1)

GRV disc (MO disc): SONY MDW-74 (fully recorded)

(4) Note

- If a disc had any stains or scars on, the adjustment may not be completed.
- Always place the main unit with its cassette cover upward for adjustment.
- Do not make any manual adjustments.
- If the adjustment is incomplete, it displays "NO ADJ" during normal operation.

(5) Prohibitions

Do not press DSL key of the remote controller. If it was pressed, the mode will change to factory shipment mode.

If any data is changed in this mode, the unit will not be able to function normally.

If accidentally change into this mode, initialize EEPROM and re-do all the adjustments.

2. Adjustment Procedures

(1) PIT Disc (TEST DISC: TGYS1)

Insert the disc and press "PLAY" key (make sure to place main unit with its cassette cover upward).

LCD of the remote controller will be displayed "AUTO ADJ H" first, then "COMPLEAT"

(2) GRV DISC (SONY MDW-74)

Insert the disc and press "PLAY" key (make sure to place main unit with its cassette cover upward).

LCD of the remote controller will be displayed "AUTO ADJ L" first, then "COMPLEAT"

- \* If it displayed "Failed" during adjustment, it means that some abnormalities are detected and the operation is terminated.

(3) Checking RF Level and Error Rate

a) Press "-" key of the remote controller. Display "032c 00e" and playback.

Check the RF waveform (TP3) with an oscilloscope and it is within the  $1.0 \pm 0.2V_{p-p}$ . If it is not, follow the instruction below to make an adjustment.

- If the value is higher than  $1.2V_{p-p}$ , short TP4.
- If the value is lower than  $0.8V_{p-p}$ , short TP5.

b) Press "+" of the remote controller. Display "600c 00e" and playback.

Make sure if the error note is below "60e".

3. Others

(1) EEPROM Initialization

Press "DISPLAY" key, while it displays "IDLE", to start initialization of EEPROM.

Once the initialization is completed, LCD displays "EP INIT OK".

- Re-adjustments are required after every initialization. Otherwise it displays "NO ADJUST!" during the normal operation.

(2) Checking Sled Operation

Press "F-SKIP" key, while it displays "IDLE", to shift puck-up towards the external circumference.

Press "B-SKIP" key, while it displays "IDLE", to shift puck-up towards the internal circumference.

MECHANICAL EXPLODED VIEW 1 / 1

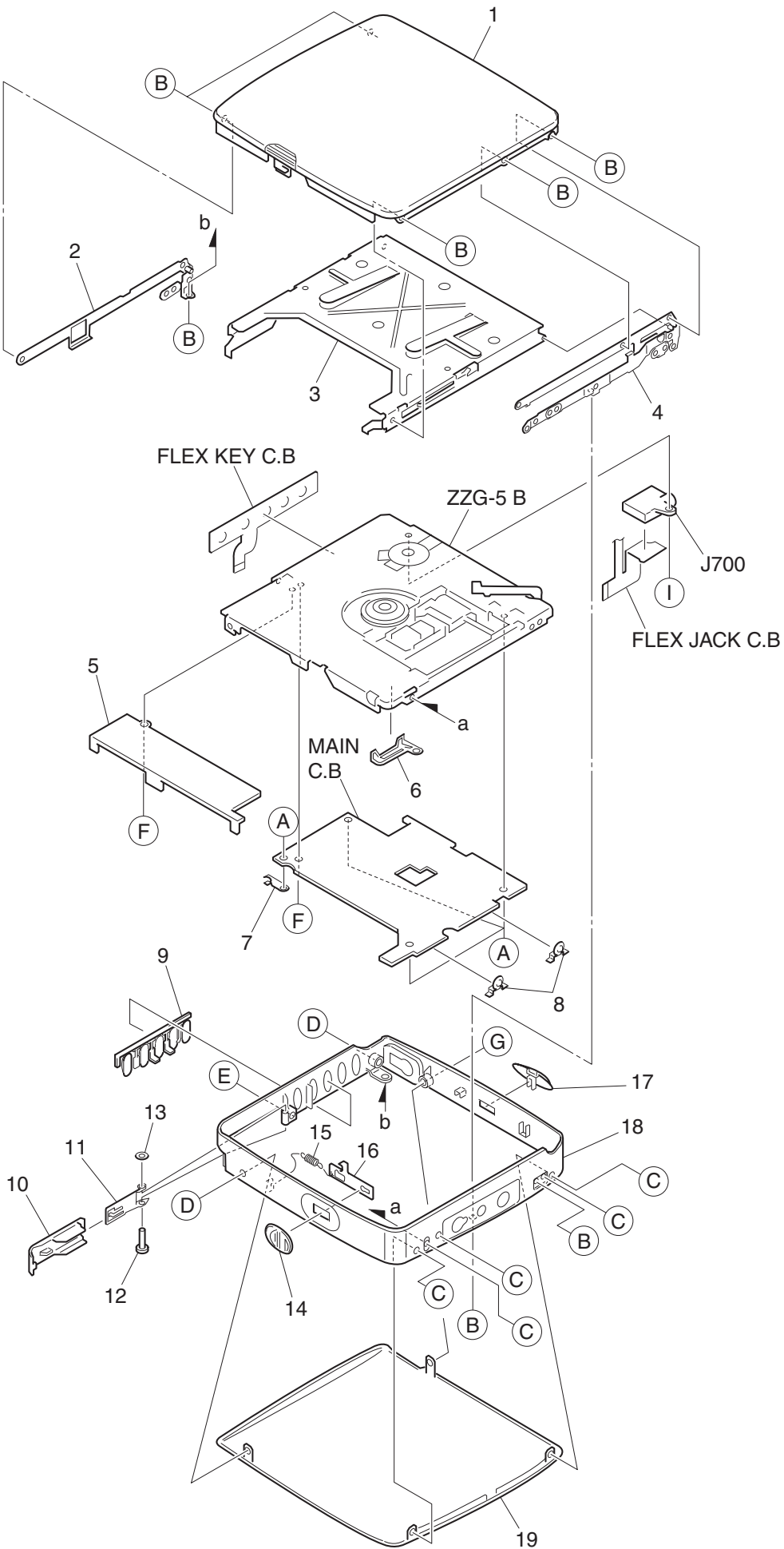

# MECHANICAL PARTS LIST 1 / 1

REF. NO.	PART NO.	KANRI NO.	DESCRIPTION
1	8A-HM6-001-010	1D	PANEL, TOP<L, AHK1L>
1	8A-HM6-010-010	--	PANEL, TOP LM<LM>
1	8A-HM6-009-010	1C	PANEL, TOP P<P, AHK1P>
1	8A-HM6-011-010	1E	PANEL, TOP Y<Y>
2	8A-HM3-205-110	1B	FRAME ASSY, L
3	8Z-ZG5-213-110	1C	HLLDR, CTRG
4	8A-HM3-201-210	1C	FRAME ASSY, R
5	8A-HM6-205-010	0E	HLLDR, BATT
6	8A-HM3-215-110	0E	BAT-CONTACT, -
7	8A-HM3-214-010	0E	BAT-CONTACT, +
8	8A-HM3-216-010	0E	BAT-CONTACT, EX
9	8A-HM6-004-010	0E	KEY, CONT MAIN
10	8A-HM6-005-010	0E	LID, BATT
11	8A-HM3-210-010	1A	HINGE ASSY, BATT
12	8A-HM3-213-010	0E	SHAFT, HINGE BATT
13	87-078-053-010	0E	W-P 0.7-2.5-0.28 SLIT
14	8A-HM6-006-010	1B	KNOB, SL SL EJECT
15	8Z-HM4-230-010	0E	SPR-E, EJECT
16	8A-HM6-201-010	0E	HLLDR, EJECT
17	8A-HM6-007-010	0E	KNOB, SL HOLD
18	8A-HM6-003-010	1A	FRAME, CENTER
19	8A-HM6-002-010	1C	PANEL, BOT<L>
19	8A-HM6-008-010	--	PANEL, BOT HK L<AHK1L>
19	8A-HM6-015-010	--	PANEL, BOT HK P<AHK1P>
19	8A-HM6-013-010	1B	PANEL, BOT LM<LM>
19	8A-HM6-012-010	--	PANEL, BOT P<P>
19	8A-HM6-014-010	--	PANEL, BOT Y<Y>
A	87-078-186-010	0E	SCRW-SR, 1.4-1.8 CR L
B	87-HM1-243-010	0E	S-SCREW, 1.4-1.4CRNL
C	87-067-596-010	0E	SCREW, V+1.4-3
D	87-078-187-010	0E	SCRW-SR, 1.4-4.5 CR L
E	8A-HM6-204-010	0E	S-SCREW, +1.4-6.5 CR
F	8A-HM3-222-010	0E	S-SCREW, +1.4-3.0 CR
G	8A-HM6-208-010	0E	S-SCREW, +1.4-5.5 CR
H	8A-HM3-233-010	0E	S-SCREW, +1.4-3.5

## COLOR NAME TABLE

Basic color symbol	Color	Basic color symbol	Color	Basic color symbol	Color
B	Black	C	Cream	D	Orange
G	Green	H	Gray	L	Blue
LT	Transparent Blue	N	Gold	P	Pink
R	Red	S	Silver	ST	Titan Silver
T	Brown	V	Violet	W	White
WT	Transparent White	Y	Yellow	YT	Transparent Yellow
LM	Metallic Blue	LL	Light Blue	GT	Transparent Green
LD	Dark Blue	DT	Transparent Orange	GM	Metallic Green
YM	Metallic Yellow	DM	Metallic Orange	PT	Transparent Pink

# MD MECHANISM EXPLODED VIEW 1 / 1

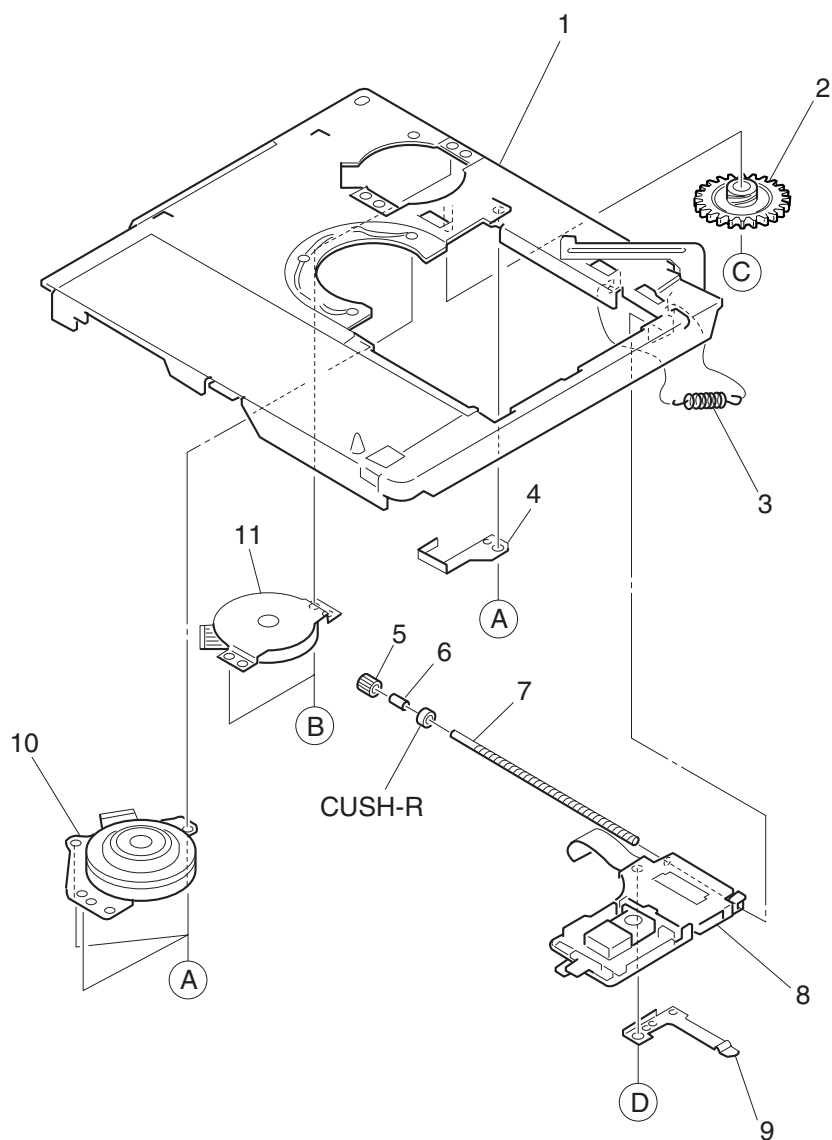

# MD MECHANISM PARTS LIST 1 / 1

REF. NO.	PART NO.	KANRI NO.	DESCRIPTION
1	8Z-ZG5-201-610	1E	CHAS ASSY, MECHA
2	8Z-ZG5-208-010	0E	GEAR, A
3	8Z-ZG5-207-010	0E	SPR-E, EJECT
4	8Z-ZG5-212-010	0E	SPR-P, LEAD
5	8Z-ZG5-209-110	0E	GEAR, B
6	8Z-ZG5-217-010	0E	BRG, 1.1-2-2
7	8Z-ZG5-210-110	1B	SHAFT, LEAD
8	87-A91-718-010	2E	PICKUP, KMS-330A
9	8Z-ZG5-219-010	0E	SPR-P, RACK 2
10	87-A91-488-010	2P	MOT, MX-2263
11	M8-ZZS-290-000	2A	ZZS-2 A
A	88-ZG6-224-010	0E	S-SCREW, VBT+1.4-3
B	87-067-393-010	0E	SCREW +1.4-1.4
C	87-067-569-010	0E	POLY WASHER 0.83-2.5-0.25
D	8Z-ZG5-223-010	0E	S-SCREW, VBT+1.4-2



## ACCESSORIES / PACKAGE LIST

REF. NO.	PART NO.	KANRI NO.	DESCRIPTION
1	8A-HM6-902-010	1B	IB, HK (ECA) S<AHK1L, AHK1P>
1	8A-HM6-908-010	1A	IB, D<Y, LM, L, P>
2	87-B30-066-210	2B	CHARGER, RB-M01<Y, LM, L, P>
2	87-B30-244-010	2P	CHARGER, RB-M02K<AHK1L, AHK1P>
3	87-B30-221-010	1B	CASE, BATTERY
4	87-B30-295-010	--	HEADPHONE, HP-M031 S<Y, LM, P, AHK1P>
4	87-B30-372-010	2M	HEADPHONE, HP-M030 L1<L, AHK1L>
5	87-B30-303-010	2P	BAT, MHB-901 (S)
6	8A-HM3-951-010	1F	BOX, BAT ASSY AHM-3<Y, LM>
6	8A-HM3-953-010	1F	BOX, BAT ASSY AHM-3 P<P, AHK1P>
6	8A-HM3-952-010	1F	BOX, BAT ASSY AHM-6 L<L, AHK1L>
7	8A-HM6-951-010	2Y	BAG CARRYING
8	8A-HM6-953-010	2B	RC UNIT, RC-CL33 L<L, AHK1L>
8	8A-HM6-955-010	2B	RC UNIT, RC-CL33 P<P, AHK1P>
8	8A-HM6-956-010	2B	RC UNIT, RC-CL33 LM<LM>
8	8A-HM6-957-010	2B	RC UNIT, RC-CL33 Y<Y>
9	8A-HM6-954-010	--	CLIP, RC-CL33

**アイワ株式会社** 〒110-8710 東京都台東区池之端1-2-11 ☎03(3827)3111 (代表)  
**AIWA CO.,LTD.** 2-11, IKENOHATA 1-CHOME, TAITO-KU, TOKYO 110, JAPAN TEL:03 (3827) 3111



**AM-CL33**

D,AHK

# SERVICE MANUAL

---

MINIDISC PLAYER

BASIC MD MECHANISM : ZZG-5 B

---

- Replace this Service manual with "Revision Publishing" when it is issued.

**aiwa**

S/M Code No. 09-003-430-9T1

SIMPLE

DATA

# ELECTRICAL MAIN PARTS LIST - 1/2

NOTE: The characters in the suffix column indicate the part usage.

Y	.....	OO	.....	A	.....
LM	.....	OO	.....	B	.....
L	.....	OO	.....	C	.....
P	.....	OO	.....	D	.....
AHK1L	.....	XX	.....	E	.....
AHK1P	.....	XX	.....	F	.....

REF.NO	PARTS NO.	KANRI NO.	DESCRIPTION	SUFFIX
*	8A-HM3-601-010	1E	PWB, FLEX JACK	ABCDEF
*	8A-HM3-602-010	1E	PWB, FLEX KEY	ABCDEF
J	700 87-A60-682-010	1B	JACK, 3.5 ST 7P	ABCDEF
C	109 87-A10-523-080	0E	C-CAP, V 2.0P-50 C CH	ABCDEF
C	108 87-A10-531-080	0E	C-CAP, V 10P-50 D CH	ABCDEF
C	107 87-A10-765-080	0E	C-CAP, V 0.033-10 K B	ABCDEF
C	106 87-A10-765-080	0E	C-CAP, V 0.033-10 K B	ABCDEF
C	105 87-A10-765-080	0E	C-CAP, V 0.033-10 K B	ABCDEF
C	104 87-A10-765-080	0E	C-CAP, V 0.033-10 K B	ABCDEF
C	102 87-A10-765-080	0E	C-CAP, V 0.033-10 K B	ABCDEF
C	103 87-A10-766-080	0E	C-CAP, V 0.047-10 K B	ABCDEF
C	101 87-A10-770-080	0E	C-CAP, V 0.1-10 K B	ABCDEF
C	115 87-A10-556-080	0E	C-CAP, V 2200P-50 K B	ABCDEF
C	111 87-A10-561-080	0E	C-CAP, V 0.01U-16 K B	ABCDEF
C	112 87-A10-561-080	0E	C-CAP, V 0.01U-16 K B	ABCDEF
C	114 87-A10-770-080	0E	C-CAP, V 0.1-10 K B	ABCDEF
C	116 87-A11-049-080	0E	C-CAP, U 1-6.3 K B	ABCDEF
C	118 87-A11-050-080	1A	C-CAP, TN 47U-4 M F95 A	ABCDEF
C	119 87-A11-050-080	1A	C-CAP, TN 47U-4 M F95 A	ABCDEF
C	117 87-A11-751-080	1A	C-CAP, TN 22U-4 M P	ABCDEF
C	110 87-A11-969-080	0E	C-CAP, U 0.082U-16 K B	ABCDEF
C	123 87-A10-554-080	0E	C-CAP, V 1000P-50 K B	ABCDEF
C	124 87-A10-554-080	0E	C-CAP, V 1000P-50 K B	ABCDEF
C	122 87-A10-561-080	0E	C-CAP, V 0.01U-16 K B	ABCDEF
C	120 87-A10-770-080	0E	C-CAP, V 0.1-10 K B	ABCDEF
C	121 87-A11-751-080	1A	C-CAP, TN 22U-4 M P	ABCDEF
CN	100 87-A61-276-080	1B	C-CONN, 20P H 545482090	ABCDEF
D	100 87-017-850-080	0E	C-DIODE, DAP222	ABCDEF
IC	100 87-A21-294-010	1H	C-IC, LA9606	ABCDEF
L	101 87-003-245-080	0E	C-COIL, 22UH	ABCDEF
L	100 87-A50-360-080	0E	C-COIL, 47UH K NLFC252018	ABCDEF
Q	100 87-A30-033-080	0E	C-FET, 2SK2035	ABCDEF
Q	101 87-A30-149-080	0E	C-FET, 2SJ347	ABCDEF
Q	102 89-115-884-080	0E	CHIP -TRANSISTER 2SA1588Y	ABCDEF
C	203 87-A10-556-080	0E	C-CAP, V 2200P-50 K B	ABCDEF
C	204 87-A10-671-080	0E	C-CAP, V 0.022-16 K B	ABCDEF
C	206 87-A10-770-080	0E	C-CAP, V 0.1-10 K B	ABCDEF
C	209 87-A10-770-080	0E	C-CAP, V 0.1-10 K B	ABCDEF
C	202 87-A10-770-080	0E	C-CAP, V 0.1-10 K B	ABCDEF
C	200 87-A10-770-080	0E	C-CAP, V 0.1-10 K B	ABCDEF
C	208 87-A10-770-080	0E	C-CAP, V 0.1-10 K B	ABCDEF
C	201 87-A11-050-080	1A	C-CAP, TN 47U-4 M F95 A	ABCDEF
C	215 87-A10-535-080	0E	C-CAP, V 22P-50 J CH	ABCDEF
C	214 87-A10-535-080	0E	C-CAP, V 22P-50 J CH	ABCDEF
C	213 87-A10-559-080	0E	C-CAP, V 6800P-25 K B	ABCDEF
C	216 87-A10-770-080	0E	C-CAP, V 0.1-10 K B	ABCDEF
C	217 87-A11-049-080	0E	C-CAP, U 1-6.3 K B	ABCDEF
C	212 87-A11-751-080	1A	C-CAP, TN 22U-4 M P	ABCDEF
C	700 87-A11-751-080	1A	C-CAP, TN 22U-4 M P	ABCDEF
IC	202 87-017-861-040	1B	IC, TC7W74FU	ABCDEF
IC	201 87-A21-526-010	2P	C-IC, GM71VLS17403CTL-1	ABCDEF
IC	200 87-A21-574-010	2Y	C-IC, LC89642	ABCDEF
IC	204 87-A21-618-040	1B	C-IC, TK70006S	ABCDEF
L	200 87-003-245-080	0E	C-COIL, 22UH	ABCDEF
Q	205 87-A30-180-040	0E	C-TR, DTC114TEA	ABCDEF
Q	204 87-A30-180-040	0E	C-TR, DTC114TEA	ABCDEF
Q	206 87-A30-180-040	0E	C-TR, DTC114TEA	ABCDEF
Q	201 87-A30-181-040	0E	C-TR, DTA114TEA	ABCDEF
Q	202 87-A30-181-040	0E	C-TR, DTA114TEA	ABCDEF
Q	203 87-A30-181-040	0E	C-TR, DTA114TEA	ABCDEF
X	200 87-A70-207-080	1B	C-VIB, 16.9344MHZ SSR-B	ABCDEF
C	406 87-A10-556-080	0E	C-CAP, V 2200P-50 K B	ABCDEF
C	404 87-A10-556-080	0E	C-CAP, V 2200P-50 K B	ABCDEF
C	407 87-A10-556-080	0E	C-CAP, V 2200P-50 K B	ABCDEF
C	403 87-A10-556-080	0E	C-CAP, V 2200P-50 K B	ABCDEF
C	402 87-A10-556-080	0E	C-CAP, V 2200P-50 K B	ABCDEF
C	405 87-A10-556-080	0E	C-CAP, V 2200P-50 K B	ABCDEF
C	409 87-A10-765-080	0E	C-CAP, V 0.033-10 K B	ABCDEF
C	401 87-A11-049-080	0E	C-CAP, U 1-6.3 K B	ABCDEF
C	408 87-A11-049-080	0E	C-CAP, U 1-6.3 K B	ABCDEF
C	400 87-A11-049-080	0E	C-CAP, U 1-6.3 K B	ABCDEF
C	410 87-A10-765-080	0E	C-CAP, V 0.033-10 K B	ABCDEF
C	412 87-A10-770-080	0E	C-CAP, V 0.1-10 K B	ABCDEF
C	411 87-A10-770-080	0E	C-CAP, V 0.1-10 K B	ABCDEF
C	413 87-A10-770-080	0E	C-CAP, V 0.1-10 K B	ABCDEF
C	415 87-A11-046-080	1B	C-CAP, TN 100U-4 M F95 B	ABCDEF

ELECTRICAL MAIN PARTS LIST - 2/2

C	416	87-A11-751-080	1A	C-CAP,TN 22U-4 M P	ABCDEF
C	417	87-A11-807-080	0E	C-CAP,TN 4.7U-6.3 M P	ABCDEF
IC	400	87-A21-575-010	2P	C-IC,BD6606KVT	ABCDEF
L	406	87-003-245-080	0E	C-COIL,22UH	ABCDEF
L	405	87-A50-011-080	0E	C-COIL,47UH LQH3C	ABCDEF
L	403	87-A50-475-080	0E	C-COIL, 10UH K NLFC201614	ABCDEF
L	400	87-A50-475-080	0E	C-COIL, 10UH K NLFC201614	ABCDEF
L	402	87-A50-475-080	0E	C-COIL, 10UH K NLFC201614	ABCDEF
L	401	87-A50-475-080	0E	C-COIL, 10UH K NLFC201614	ABCDEF
C	707	87-016-449-080	1A	C-CAP,TN 10-4 F95 P	ABCDEF
C	708	87-016-449-080	1A	C-CAP,TN 10-4 F95 P	ABCDEF
C	702	87-A10-543-080	0E	C-CAP,V 100P-50 J CH	ABCDEF
C	704	87-A10-543-080	0E	C-CAP,V 100P-50 J CH	ABCDEF
C	703	87-A10-543-080	0E	C-CAP,V 100P-50 J CH	ABCDEF
C	705	87-A10-543-080	0E	C-CAP,V 100P-50 J CH	ABCDEF
C	706	87-A11-049-080	0E	C-CAP,U 1-6.3 K B	ABCDEF
C	709	87-A11-058-080	0E	C-CAP,U 0.22-10 K B	ABCDEF
C	717	87-A11-049-080	0E	C-CAP,U 1-6.3 K B	ABCDEF
C	711	87-A11-049-080	0E	C-CAP,U 1-6.3 K B	ABCDEF
C	712	87-A11-049-080	0E	C-CAP,U 1-6.3 K B	ABCDEF
C	710	87-A11-058-080	0E	C-CAP,U 0.22-10 K B	ABCDEF
C	715	87-A11-318-080	1B	C-CAP,TN 220U-2.5 SVB2	ABCDEF
C	716	87-A11-318-080	1B	C-CAP,TN 220U-2.5 SVB2	ABCDEF
C	713	87-A11-751-080	1A	C-CAP,TN 22U-4 M P	ABCDEF
C	720	87-A11-058-080	0E	C-CAP,U 0.22-10 K B	ABCDEF
CN	700	87-A60-954-080	1B	C-CONN,16P H 54548-1611	ABCDEF
IC	700	87-A21-341-040	1D	C-IC,TA2131FL	ABCDEF
L	701	87-005-769-080	1A	C-COIL,S 100UH K	ABCDEF
L	702	87-A50-233-080	1A	C-COIL,ACM4532-102-3P	ABCDEF
R	701	87-A50-208-080	0E	C-COIL,BLM11A601SPT	ABCDEF
R	702	87-A50-208-080	0E	C-COIL,BLM11A601SPT	ABCDEF
C	304	87-A10-561-080	0E	C-CAP,V 0.01U-16 K B	ABCDEF
C	301	87-A10-561-080	0E	C-CAP,V 0.01U-16 K B	ABCDEF
C	302	87-A10-561-080	0E	C-CAP,V 0.01U-16 K B	ABCDEF
C	303	87-A10-561-080	0E	C-CAP,V 0.01U-16 K B	ABCDEF
C	309	87-A10-770-080	0E	C-CAP,V 0.1-10 K B	ABCDEF
C	300	87-A10-770-080	0E	C-CAP,V 0.1-10 K B	ABCDEF
C	308	87-A10-770-080	0E	C-CAP,V 0.1-10 K B	ABCDEF
C	305	87-A11-050-080	1A	C-CAP,TN 47U-4 M F95 A	ABCDEF
C	701	87-A10-770-080	0E	C-CAP,V 0.1-10 K B	ABCDEF
CN	300	87-A61-020-080	1A	C-CONN,4P H 54550-0417	ABCDEF
D	300	87-A40-556-080	0E	C-LED,CL-270HR RED	ABCDEF
IC	301	87-A21-030-040	1B	C-IC,S-93C46AMFN	ABCDEF
IC	302	87-A21-038-040	1B	C-IC,NJU7014R-TE2	ABCDEF
IC	300	8A-HM6-600-010	2P	C-IC,LC87F5164A	ABCDEF
L	300	87-003-245-080	0E	C-COIL,22UH	ABCDEF
Q	301	87-A30-033-080	0E	C-FET,2SK2035	ABCDEF
Q	300	87-A30-149-080	0E	C-FET,2SJ347	ABCDEF
R	305	87-022-239-080	0E	C-RES U 10K-1/16WF	ABCDEF
R	306	87-022-249-080	0E	C-RES U27K 1/16WF	ABCDEF
S	301	87-A90-703-080	0E	C-SW,SL 1-1-3 SSSS813-B-2B	ABCDEF
S	300	87-A91-436-080	1A	C-SW,PUSH 2-1-1 SPVE3.8	ABCDEF
X	300	87-A70-212-080	1B	C-VIB,3.00MHZ PBRC-B	ABCDEF
C	605	87-A10-554-080	0E	C-CAP,V 1000P-50 K B	ABCDEF
C	601	87-A10-557-080	0E	C-CAP,V 3300P-25 K B	ABCDEF
C	609	87-A10-561-080	0E	C-CAP,V 0.01U-16 K B	ABCDEF
C	604	87-A10-770-080	0E	C-CAP,V 0.1-10 K B	ABCDEF
C	603	87-A10-770-080	0E	C-CAP,V 0.1-10 K B	ABCDEF
C	607	87-A11-049-080	0E	C-CAP,U 1-6.3 K B	ABCDEF
C	608	87-A11-751-080	1A	C-CAP,TN 22U-4 M P	ABCDEF
C	602	87-A11-806-080	1B	C-CAP,TN 47U-6.3 M PSLB	ABCDEF
C	600	87-A11-806-080	1B	C-CAP,TN 47U-6.3 M PSLB	ABCDEF
C	606	87-A11-807-080	0E	C-CAP,TN 4.7U-6.3 M P	ABCDEF
C	610	87-A10-770-080	0E	C-CAP,V 0.1-10 K B	ABCDEF
D	601	87-017-850-080	0E	C-DIODE,DAP222	ABCDEF
D	602	87-A40-124-080	0E	C-DIODE,RB501V-40	ABCDEF
D	600	87-A40-687-080	0E	C-DIODE,M1FH3	ABCDEF
IC	601	87-A20-861-040	1A	C-IC,S-80808ANNP	ABCDEF
IC	602	87-A20-982-040	1A	C-IC,S-80822ANNP	ABCDEF
IC	600	87-A21-316-080	1B	C-IC,S-8328B24MC	ABCDEF
IC	603	87-A21-627-040	1B	C-IC,XC6367B103MR	ABCDEF
L	601	87-A50-012-080	0E	C-COIL,100UH LQH3C	ABCDEF
L	600	87-A50-537-080	1A	C-COIL, 100UH C4-K3L	ABCDEF
PR	600	87-A91-769-080	1A	C-PROTECTOR,0.75A ERY32SB075	ABCDEF
PR	601	87-A91-769-080	1A	C-PROTECTOR,0.75A ERY32SB075	ABCDEF
Q	604	87-A30-147-080	0E	C-TR,2SA1832GR	ABCDEF
Q	606	87-A30-181-040	0E	C-TR,DTA114TEA	ABCDEF
Q	601	87-A30-261-080	1B	C-FET,FDC633N	ABCDEF
Q	600	87-A30-261-080	1B	C-FET,FDC633N	ABCDEF
Q	605	87-A30-261-080	1B	C-FET,FDC633N	ABCDEF
Q	602	87-A30-262-080	1B	C-FET,FDC634P	ABCDEF
Q	603	89-332-654-080	0E	CHIP TRANSISTOR, 2SC3265Y	ABCDEF

# MECHANICAL PARTS LIST - 1/1

NOTE: The characters in the suffix column indicate the part usage.

```

Y .....OO.....A.....
LM .....OO.....B.....
L .....OO.....C.....
P .....OO.....D.....
AHK1L .....XX.....E.....
AHK1P .....XX.....F.....

```

REF.NO	PARTS NO.	KANRI NO.	DESCRIPTION	SUFFIX
	8A-HM6-001-010		PANEL, TOP	..C.E.....
	8A-HM6-003-010		FRAME, CENTER	ABCDEF.....
	8A-HM6-005-010		LID, BATT	ABCDEF.....
	8A-HM6-009-010		PANEL, TOP P	...D.F.....
	8A-HM6-010-010		PANEL, TOP LM	.B.....
	8A-HM6-011-010		PANEL, TOP Y	A.....
	8A-HM6-004-010		KEY, CONT MAIN	ABCDEF.....
	8A-HM6-006-010	1B	KNOB, SL SL EJECT	ABCDEF.....
	8A-HM6-007-010		KNOB, SL HOLD	ABCDEF.....
	8A-HM6-002-010		PANEL, BOT	..C.....
	8A-HM6-008-010	1B	PANEL, BOT HK L	...E.....
	8A-HM6-012-010		PANEL, BOT P	...D.....
	8A-HM6-013-010		PANEL, BOT LM	.B.....
	8A-HM6-014-010		PANEL, BOT Y	A.....
	8A-HM6-015-010		PANEL, BOT HK P	...F.....
	8A-HM6-016-010		PANEL, BOT HK Y	.....
	87-078-053-010	0E	PW 2.5-0.7-0.25 SLT	ABCDEF.....
	8A-HM3-201-210	1C	FRAME ASSY, R	ABCDEF.....
	8A-HM3-205-110	1B	FRAME ASSY, L	ABCDEF.....
	8A-HM3-210-010	1A	HINGE ASSY, BATT	ABCDEF.....
	8A-HM3-213-010	0E	SHAFT, HINGE BATT	ABCDEF.....
	8A-HM3-214-010	0E	BAT-CONTACT, +	ABCDEF.....
	8A-HM3-215-110	0E	BAT-CONTACT, -	ABCDEF.....
	8A-HM3-216-010	0E	BAT-CONTACT, EX	ABCDEF.....
	8A-HM6-201-010		HLDR, EJECT	ABCDEF.....
	8A-HM6-205-010	0E	HLDR, BATT	ABCDEF.....
	8Z-HM4-230-010	0E	SPR-E, EJECT	ABCDEF.....
	8Z-ZG5-213-110	1C	HLDR, CTRG	ABCDEF.....
	87-078-186-010	0E	SCRW-SR, 1.4-1.8 CR L	ABCDEF.....
	87-078-187-010	0E	SCRW-SR, 1.4-4.5 CR L	ABCDEF.....
	87-B10-178-010	0E	VT2+1.4-4.5 W/O SLOT BLK HL	ABCDEF.....
	87-HM1-242-010	0E	S-SCREW, 1.4-2.0CR	ABCDEF.....
	87-HM1-243-010	0E	S-SCREW, 1.4-1.4CRNL	ABCDEF.....
	88-ZG2-256-010	0E	S-SCREW, +1.4-3.5	ABCDEF.....
	8A-HM3-222-010	0E	S-SCREW, +1.4-3.0 CR	ABCDEF.....
*	87-067-596-010	0E	SCREW, V+1.4-3	ABCDEF.....
*	8A-HM6-204-010		S-SCREW, +1.4-6.5 CR	ABCDEF.....

# ACCESSORIES / PACKAGE LIST - 1/1

NOTE: The characters in the suffix column indicate the part usage.

Y	.....OO	.....A
LM	.....OO	.....B
L	.....OO	.....C
P	.....OO	.....D
AHK1L	.....XX	.....E
AHK1P	.....XX	.....F

REF.NO	PARTS NO.	KANRI NO.	DESCRIPTION	SUFFIX
	8A-HM6-902-010	1B	IB, HK (ECA) S	.....EF
	8A-HM6-908-010	1A	IB, D	ABCD
	87-B30-066-210	2B	CHARGER, RB-M01	ABCD
	87-B30-221-010	1B	CASE, BATTERY	ABCDEF
	87-B30-244-010	2P	CHARGER, RB-M02K	.....EF
	87-B30-295-010		HEADPHONE, HP-M031 S	AB.D.F
	87-B30-303-010	2P	BAT, MHB-901 (S)	ABCDEF
	87-B30-372-010	2M	HEADPHONE, HP-M031 L1	..C.E
	8A-HM3-951-010	1F	BOX, BAT ASSY AHM-3	AB
	8A-HM3-953-010	1F	BOX, BAT ASSY AHM-3 P	..D.F
	8A-HM6-951-010	2Y	BAG, CARRING	ABCDEF
	8A-HM6-952-010	1F	BOX, BAT ASSY AHM-6 L	..C.E
	8A-HM6-953-010	2B	RC UNIT, RC-CL33 L	..C.E
	8A-HM6-954-010		CLIP, RC-CL33	ABCDEF
	8A-HM6-955-010	2B	RC UNIT, RC-CL33 P	..D.F
	8A-HM6-956-010	2B	RC UNIT, RC-CL33 LM	.B
	8A-HM6-957-010	2B	RC UNIT, RC-CL33 Y	A

SCHEMATIC DIAGRAM (MAIN)

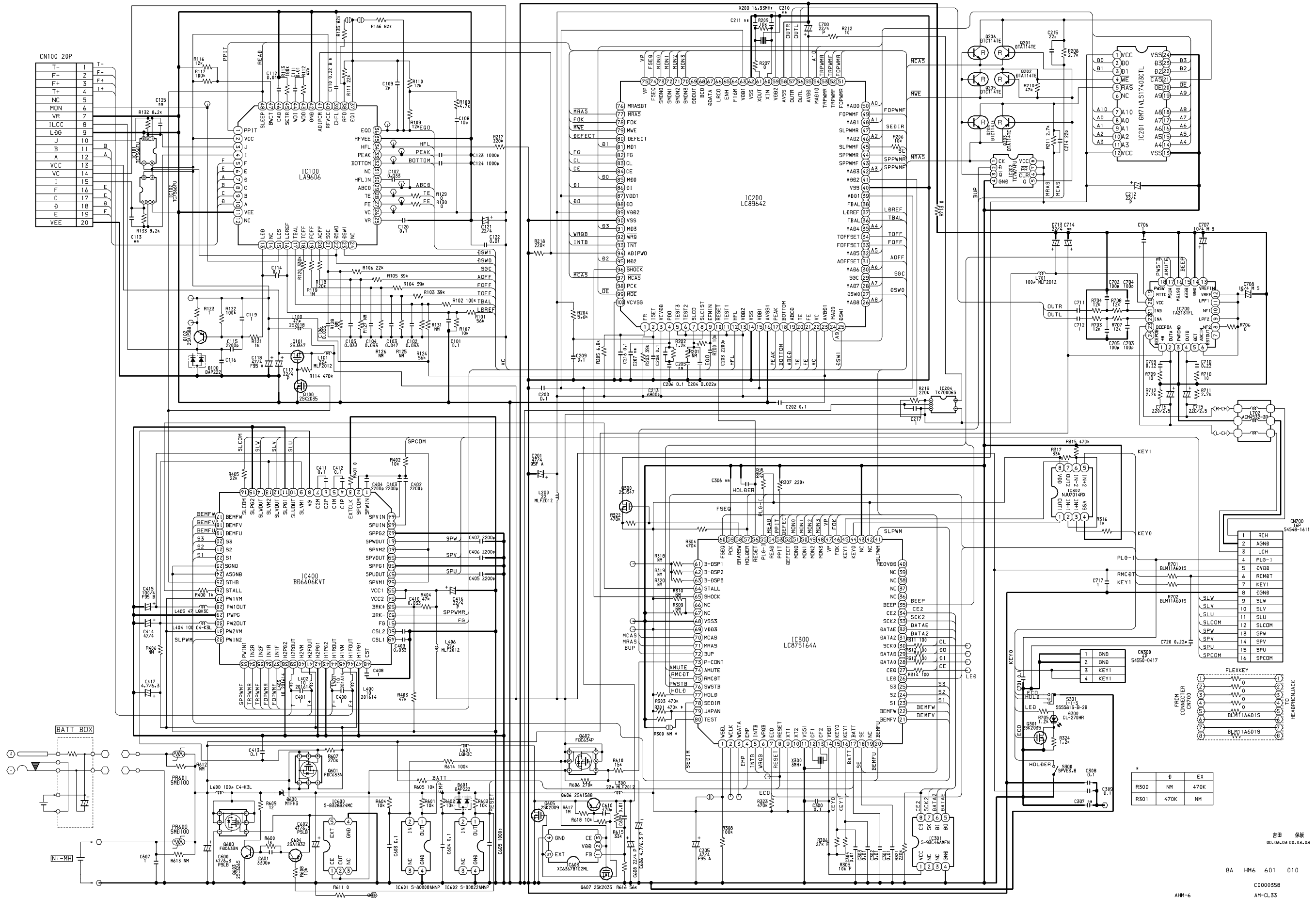



**アイワ株式会社** 〒110-8710 東京都台東区池之端1-2-11 ☎03(3827)3111 (代表)  
**AIWA CO.,LTD.** 2-11, IKENOHATA 1-CHOME, TAITO-KU, TOKYO 110, JAPAN TEL:03 (3827) 3111



**AM-CL33**

AHK

**AM-HX50**

AHK,AK,AEZ

**AM-HX55**

AHK,AEZ

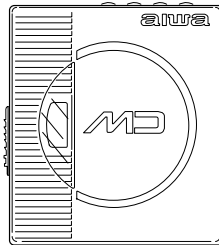

<AM-HX50>  
<AM-HX55>

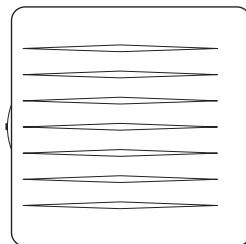

<AM-CL33>

# SERVICE MANUAL

MINIDISC PLAYER

BASIC MD MECHANISM : ZZG-5 A, ZZG-5 B

MODELS	MD MECHANISM
AM-CL33	ZZG-5 B
AM-HX50/55	ZZG-5 A

- This Supplement Manual is issued because of some changes in MD mechanism for models AM-CL33(AHK),(S/M Code No. 09-007-430-9R2), AM-HX50/55(AHK),(S/M Code No. 09-999-335-5R2) and AM-HX50/55(AK,AEZ),(S/M Code No. 09-999-335-5R3).

**aiwa**

S/M Code No. 09-00B-430-9S2

SUPPLEMENT  
DATA

# MD MECHANISM EXPLODED VIEW 1 / 1 (ZZG-5 A)

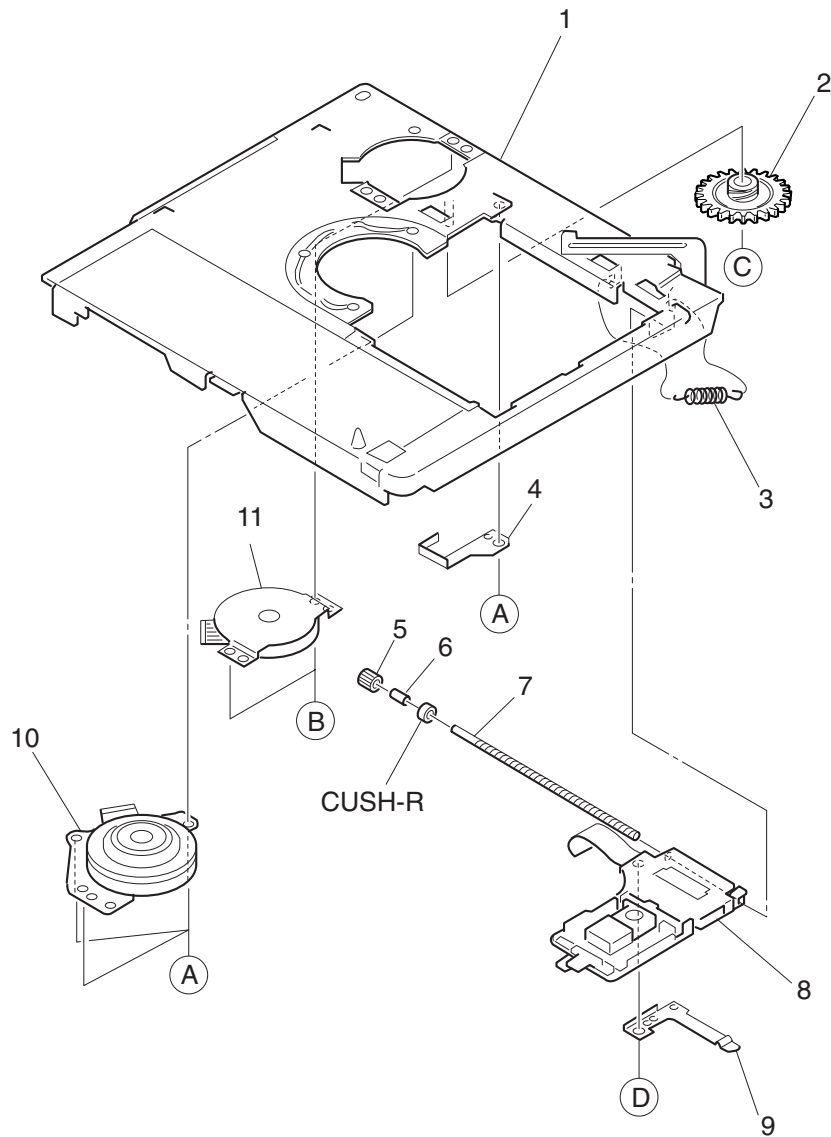

# MD MECHANISM PARTS LIST 1 / 1 (ZZG-5 A)

REF. NO.	PART NO.	KANRI NO.	DESCRIPTION
1	8Z-ZG5-201-010		CHAS ASSY, MECHA
2	8Z-ZG5-208-010		GEAR, A
3	8Z-ZG5-207-010		SPR-E, EJECT
4	8Z-ZG5-212-010		SPR-P, LEAD
5	8Z-ZG5-209-110		GEAR, B
6	8Z-ZG5-217-010		BRG, 1.1-2-2
7	8Z-ZG5-210-110		SHAFT, LEAD
8	87-A91-414-010		PICKUP, KLR2000
9	8Z-ZG5-211-010		SPR-P, RACK
10	87-A91-488-010		MOT, MX-2263
11	M8-ZZS-290-000		ZZS-2 A
A	88-ZG6-224-010		S-SCREW, VBT+1.4-3
B	87-067-393-010		SCREW +1.4-1.4
C	87-067-569-010		POLY WASHER 0.83-2.5-0.25
D	87-067-511-010		S-SCREW, VBT+1.4-2 BK

# MD MECHANISM EXPLODED VIEW 1 / 1 (ZZG-5 B)

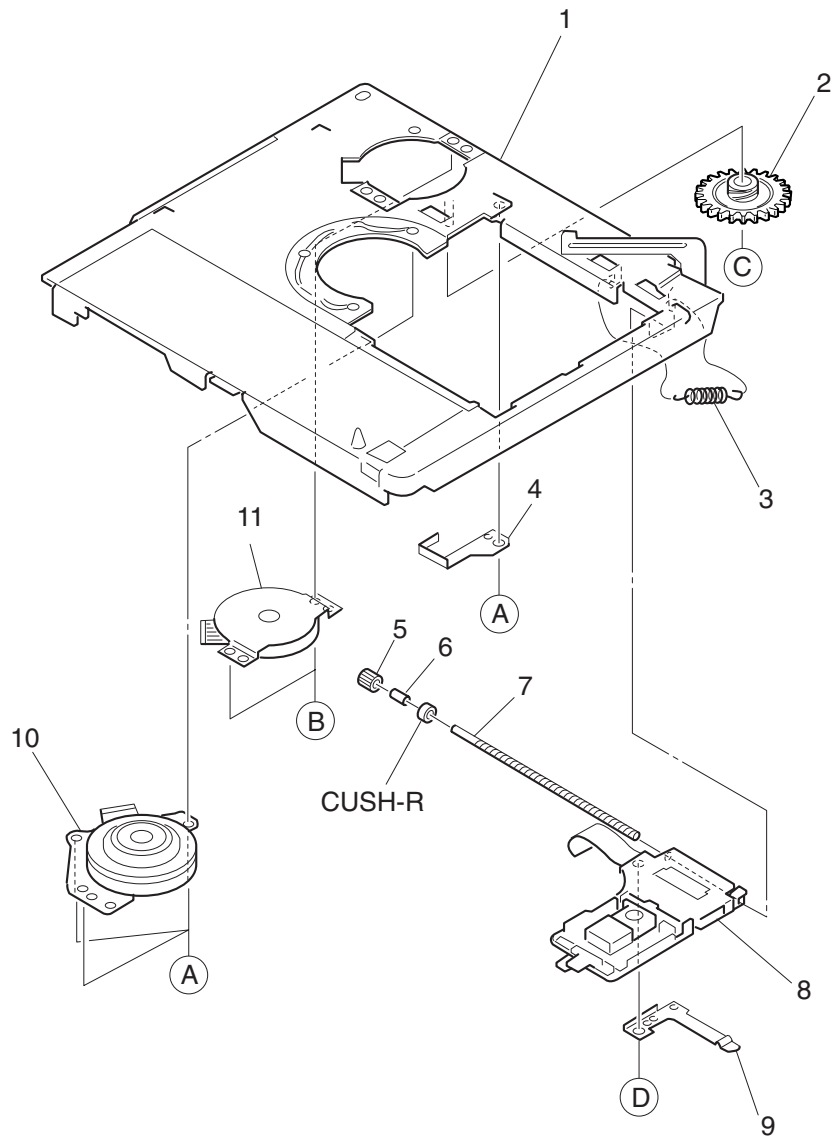

# MD MECHANISM PARTS LIST 1 / 1 (ZZG-5 B)

REF. NO.	PART NO.	KANRI NO.	DESCRIPTION
1	8Z-ZG5-201-610		CHAS ASSY, MECHA
2	8Z-ZG5-208-010		GEAR, A
3	8Z-ZG5-207-010		SPR-E, EJECT
4	8Z-ZG5-212-010		SPR-P, LEAD
5	8Z-ZG5-209-110		GEAR, B
6	8Z-ZG5-217-010		BRG, 1.1-2-2
7	8Z-ZG5-210-110		SHAFT, LEAD
8	87-A91-718-010		PICKUP, KMS-330A
9	8Z-ZG5-219-010		SPR-P, RACK 2
10	87-A91-488-010		MOT, MX-2263
11	M8-ZZS-290-000		ZZS-2 A
A	88-ZG6-224-010		S-SCREW, VBT+1.4-3
B	87-067-393-010		SCREW +1.4-1.4
C	87-067-569-010		POLY WASHER 0.83-2.5-0.25
D	8Z-ZG5-223-010		S-SCREW, VBT+1.4-2

**アイワ株式会社** 〒110-8710 東京都台東区池之端1-2-11 ☎03(3827)3111 (代表)  
**AIWA CO.,LTD.** 2-11, IKENOHATA 1-CHOME, TAITO-KU, TOKYO 110, JAPAN TEL:03 (3827) 3111