

aiwa



AM-LM99

MINI DISC RECORDER

• BASIC MD MECHANISM: 7ZG-9 B1

• TYPE: U

SIMPLE MANUAL

• Replace this Service Manual with "Revision Publishing" when it is issued.

S/M Code No. 09-997-417-0T1

MANUAL
SERVICE

ELECTRICAL MAIN PARTS LIST - 1/1

NOTE: The characters in the suffix column indicate the part usage.

REF.NO	PARTS NO.	NO.	DESCRIPTION	SUFFIX
U		XX		A
		KANRI		
*	8Z-CE3-203-010		GUIDE,LED L	AB
*	8Z-CE3-204-010		GUIDE,LED R	AB
CN	905	87-A60-083-010	CONN,04P H 9604S-04F	A
CN	903	87-A60-422-010	CONN,8P V TOC-B	AB
CN	902	87-A60-423-010	CONN,14P V TOC-B	AB
CN	904	87-A60-586-010	CONN,4P V FE	AB
CN	905	87-A60-586-010	CONN,4P V FE	AB
CN	907	87-A60-619-010	CONN,2P V 2MM JMT	AB
CN	906	87-A60-619-010	CONN,2P V 2MM JMT	AB
CN	901	87-A61-039-010	CONN,19P V WHT 52328	AB
CN	909	88-805-020-790	CONN ASSY,2P 70MM	.B
CN	909	88-805-021-090	CONN ASSY,2P	A
CN	908	88-805-021-590	CONN ASSY,2P	AB
D	901	87-A40-640-010	LED,SELULE10CXM BLUE-EF	AB
D	902	87-A40-640-010	LED,SELULE10CXM BLUE-EF	AB
S	902	87-A90-696-080	SW,TACT TS2103-03-430	AB
S	904	87-A90-696-080	SW,TACT TS2103-03-430	AB
S	906	87-A90-696-080	SW,TACT TS2103-03-430	AB
S	903	87-A90-696-080	SW,TACT TS2103-03-430	AB
S	909	87-A90-696-080	SW,TACT TS2103-03-430	AB
S	907	87-A90-696-080	SW,TACT TS2103-03-430	AB
S	905	87-A90-696-080	SW,TACT TS2103-03-430	AB
S	908	87-A90-696-080	SW,TACT TS2103-03-430	AB
S	901	87-A90-696-080	SW,TACT TS2103-03-430	AB
S	910	87-A90-696-080	SW,TACT TS2103-03-430	AB
C	903	87-010-178-080	CHIP CAP 1000P	AB
C	906	87-010-178-080	CHIP CAP 1000P	AB
C	904	87-010-196-080	CHIP CAPACITOR,0.1-25	AB
C	901	87-010-196-080	CHIP CAPACITOR,0.1-25	AB
C	907	87-010-196-080	CHIP CAPACITOR,0.1-25	AB
C	902	87-010-374-080	CAP, ELECT 47-10V	AB
C	905	87-010-374-080	CAP, ELECT 47-10V	AB
IC	901	87-A20-625-010	IC,RX178A	AB
IC	902	87-A20-625-010	IC,RX178A	AB
IC	903	87-A21-175-040	C-IC,TC74VHC14FT	AB
Q	904	87-A30-071-080	C-TR,RT1N 144C	AB
Q	905	87-A30-071-080	C-TR,RT1N 144C	AB
Q	906	87-A30-074-080	C-TR,RT1P 141C	AB
Q	903	87-A30-074-080	C-TR,RT1P 141C	AB
Q	901	87-A30-087-080	C-FET,2SK2158	AB
Q	902	87-A30-087-080	C-FET,2SK2158	AB

ELECTRICAL MAIN PARTS LIST - 1/3 (MD: 7ZG-9)

NOTE: The characters in the suffix column indicate the part usage.

REF.NO	PARTS NO.	KANRI NO.	DESCRIPTION	SUFFIX
B1	XX	A
C	507	87-010-661-080	0E C-CAP,E 10-16	AB
C	505	87-010-662-080	0E C-CAP,E 22-6.3	AB
C	503	87-010-662-080	0E C-CAP,E 22-6.3	AB
C	509	87-010-662-080	0E C-CAP,E 22-6.3	AB
C	501	87-010-831-080	0E C-CAP,U,0.1-16F	AB
C	508	87-010-831-080	0E C-CAP,U,0.1-16F	AB
C	502	87-010-831-080	0E C-CAP,U,0.1-16F	AB
C	506	87-010-831-080	0E C-CAP,U,0.1-16F	AB
C	504	87-010-831-080	0E C-CAP,U,0.1-16F	AB
C	514	87-010-661-080	0E C-CAP,E 10-16	AB
C	511	87-010-661-080	0E C-CAP,E 10-16	AB
C	513	87-010-661-080	0E C-CAP,E 10-16	AB
C	519	87-010-831-080	0E C-CAP,U,0.1-16F	AB
C	510	87-010-831-080	0E C-CAP,U,0.1-16F	AB
C	518	87-012-278-080	0E C-CAP,U 2200P-50 B	AB
C	517	87-012-278-080	0E C-CAP,U 2200P-50 B	AB
C	515	87-012-337-080	0E C-CAP,U 56P-50 CH	AB
C	516	87-012-337-080	0E C-CAP,U 56P-50 CH	AB
C	522	87-010-661-080	0E C-CAP,E 10-16	AB
C	520	87-010-661-080	0E C-CAP,E 10-16	AB
C	528	87-010-661-080	0E C-CAP,E 10-16	AB
C	527	87-010-661-080	0E C-CAP,E 10-16	AB
C	523	87-010-662-080	0E C-CAP,E 22-6.3	AB
C	524	87-010-662-080	0E C-CAP,E 22-6.3	AB
C	521	87-010-831-080	0E C-CAP,U,0.1-16F	AB
C	526	87-012-274-080	0E CHIP CAP,U 1000P-50B	AB
C	525	87-012-274-080	0E CHIP CAP,U 1000P-50B	AB
C	531	87-010-831-080	0E C-CAP,U,0.1-16F	AB
C	530	87-010-831-080	0E C-CAP,U,0.1-16F	AB
FB	501	87-A90-828-080	0E C-F-BEAD, BK1608LM182	AB
IC	501	87-017-853-040	1B IC,NJM2100V	AB
IC	500	87-A20-698-080	2M C-IC,AK4512VF	AB
IC	500	87-A21-110-040	2A C-IC,AK4519VF	AB
L	505	87-005-774-080	1B C-COIL,4BLH	AB
L	504	87-005-774-080	1B C-COIL,4BLH	AB
L	503	87-A50-116-080	0E C-COIL,4.7UHLQH3C	AB
L	502	87-A50-116-080	0E C-COIL,4.7UHLQH3C	AB
L	501	87-A50-116-080	0E C-COIL,4.7UHLQH3C	AB
C	104	87-010-662-080	0E C-CAP,E 22-6.3	AB
C	103	87-010-787-080	0E CAP, U 0.022-25	AB
C	105	87-010-831-080	0E C-CAP,U,0.1-16F	AB
C	107	87-012-195-080	0E C-CAP,U 100P-50CH	AB
C	108	87-012-274-080	0E CHIP CAP,U 1000P-50B	AB
C	102	87-012-286-080	0E CAP, U 0.01-25	AB
C	100	87-016-296-080	1A C-CAP,TN 22-4SV(A)	AB
C	101	87-016-296-080	1A C-CAP,TN 22-4SV(A)	AB
C	109	87-016-436-080	1B C-CAP,TN 47-4(B2)	AB
C	106	87-016-462-080	0E C-CAP,S 1-16 F	AB
C	114	87-010-828-080	0E CHIP CAPACITOR,U 0.033-25F	AB
C	118	87-012-282-080	0E CAP, U 4700P-50	AB
C	116	87-012-282-080	0E CAP, U 4700P-50	AB
C	113	87-012-284-080	0E CAP, U 6800P-50	AB
C	112	87-012-286-080	0E CAP, U 0.01-25	AB
C	111	87-016-296-080	1A C-CAP,TN 22-4SV(A)	AB
C	117	87-016-462-080	0E C-CAP,S 1-16 F	AB
C	119	87-016-491-080	0E C-CAP,S 0.22-16 FZ	AB
C	115	87-A10-369-080	0E C-CAP,S 0.47-16 K B	AB
C	124	87-010-662-080	0E C-CAP,E 22-6.3	AB
C	125	87-010-662-080	0E C-CAP,E 22-6.3	AB
C	120	87-010-787-080	0E CAP, U 0.022-25	AB
C	122	87-010-829-080	0E CAP, U 0.047-16	AB
C	126	87-010-831-080	0E C-CAP,U,0.1-16F	AB
C	121	87-012-286-080	0E CAP, U 0.01-25	AB
C	123	87-012-286-080	0E CAP, U 0.01-25	AB
C	203	87-010-785-080	0E C-CAP,U0.015-25BK	AB
C	201	87-010-831-080	0E C-CAP,U,0.1-16F	AB
C	202	87-010-831-080	0E C-CAP,U,0.1-16F	AB
C	209	87-010-831-080	0E C-CAP,U,0.1-16F	AB
C	205	87-010-831-080	0E C-CAP,U,0.1-16F	AB
C	206	87-012-270-080	0E CAP, U 470P-50	AB
C	208	87-012-286-080	0E CAP, U 0.01-25	AB
C	204	87-016-461-080	0E C-CAP,S 0.47-16F	AB
C	207	87-016-461-080	0E C-CAP,S 0.47-16F	AB
C	213	87-010-662-080	0E C-CAP,E 22-6.3	AB
C	218	87-012-172-080	0E CAPACITOR CHIP U 10P CH	AB
C	210	87-012-172-080	0E CAPACITOR CHIP U 10P CH	AB
C	211	87-012-172-080	0E CAPACITOR CHIP U 10P CH	AB
C	217	87-012-188-080	0E C-CAP,U 47P-50 CH	AB
C	212	87-012-195-080	0E C-CAP,U 100P-50CH	AB
C	214	87-012-274-080	0E CHIP CAP,U 1000P-50B	AB
C	219	87-016-296-080	1A C-CAP,TN 22-4SV(A)	AB
C	220	87-010-662-080	0E C-CAP,E 22-6.3	AB
C	226	87-010-831-080	0E C-CAP,U,0.1-16F	AB
C	225	87-010-831-080	0E C-CAP,U,0.1-16F	AB
C	223	87-010-831-080	0E C-CAP,U,0.1-16F	AB

ELECTRICAL MAIN PARTS LIST - 2/3 (MD: 7ZG-9)

C	221	87-010-831-080	0E	C-CAP,U,0.1-16F	AB.....
C	228	87-012-274-080	0E	CHIP CAP,U 1000P-50B	AB.....
C	229	87-012-274-080	0E	CHIP CAP,U 1000P-50B	AB.....
C	227	87-012-274-080	0E	CHIP CAP,U 1000P-50B	AB.....
C	222	87-016-444-080	1B	C-CAP,TN 47-10 F95E	AB.....
C	224	87-A10-685-080	0E	C-CAP,S 470P-100 J CH	AB.....
C	236	87-010-831-080	0E	C-CAP,U,0.1-16F	AB.....
C	232	87-012-274-080	0E	CHIP CAP,U 1000P-50B	AB.....
C	233	87-012-274-080	0E	CHIP CAP,U 1000P-50B	AB.....
C	307	87-010-831-080	0E	C-CAP,U,0.1-16F	AB.....
C	308	87-010-831-080	0E	C-CAP,U,0.1-16F	AB.....
C	301	87-010-831-080	0E	C-CAP,U,0.1-16F	AB.....
C	302	87-010-831-080	0E	C-CAP,U,0.1-16F	AB.....
C	300	87-010-831-080	0E	C-CAP,U,0.1-16F	AB.....
C	305	87-016-462-080	0E	C-CAP,S 1-16 F	AB.....
C	311	87-010-662-080	0E	C-CAP,E 22-6.3	AB.....
C	312	87-012-195-080	0E	C-CAP,U 100P-50CH	AB.....
C	325	87-012-274-080	0E	CHIP CAP,U 1000P-50B	AB.....
C	321	87-012-274-080	0E	CHIP CAP,U 1000P-50B	AB.....
C	322	87-012-274-080	0E	CHIP CAP,U 1000P-50B	AB.....
C	324	87-012-274-080	0E	CHIP CAP,U 1000P-50B	AB.....
C	323	87-012-274-080	0E	CHIP CAP,U 1000P-50B	AB.....
C	405	87-010-661-080	0E	C-CAP,E 10-16	AB.....
C	406	87-010-779-080	0E	C-CAP,E 100-6.3	AB.....
C	403	87-010-831-080	0E	C-CAP,U,0.1-16F	AB.....
C	400	87-010-831-080	0E	C-CAP,U,0.1-16F	AB.....
C	404	87-010-831-080	0E	C-CAP,U,0.1-16F	AB.....
C	401	87-010-831-080	0E	C-CAP,U,0.1-16F	AB.....
C	402	87-010-831-080	0E	C-CAP,U,0.1-16F	AB.....
C	407	87-012-197-080	0E	C-CAP,U 150P-50 CH	AB.....
C	408	87-012-197-080	0E	C-CAP,U 150P-50 CH	AB.....
C	413	87-012-197-080	0E	C-CAP,U 150P-50 CH	AB.....
C	414	87-012-197-080	0E	C-CAP,U 150P-50 CH	AB.....
C	417	87-012-268-080	0E	C-CAP,U 330P-50 B	AB.....
C	418	87-012-268-080	0E	C-CAP,U 330P-50 B	AB.....
C	411	87-012-271-080	0E	CAP, U 560P-50	AB.....
C	412	87-012-271-080	0E	CAP, U 560P-50	AB.....
C	429	87-012-286-080	0E	CAP, U 0.01-25	AB.....
C	424	87-012-286-080	0E	CAP, U 0.01-25	AB.....
C	423	87-012-286-080	0E	CAP, U 0.01-25	AB.....
C	431	87-010-779-080	0E	C-CAP,E 100-6.3	AB.....
C	434	87-010-831-080	0E	C-CAP,U,0.1-16F	AB.....
C	430	87-012-286-080	0E	CAP, U 0.01-25	AB.....
C	600	87-010-662-080	0E	C-CAP,E 22-6.3	AB.....
C	603	87-010-662-080	0E	C-CAP,E 22-6.3	AB.....
C	601	87-010-779-080	0E	C-CAP,E 100-6.3	AB.....
C	602	87-010-779-080	0E	C-CAP,E 100-6.3	AB.....
C	604	87-010-779-080	0E	C-CAP,E 100-6.3	AB.....
C	607	87-010-831-080	0E	C-CAP,U,0.1-16F	AB.....
C	608	87-010-831-080	0E	C-CAP,U,0.1-16F	AB.....
C	605	87-012-286-080	0E	CAP, U 0.01-25	AB.....
CN	401	87-A60-062-010	0E	CONN,05P V 9604S-05C	AB.....
D	101	87-001-166-080	0E	DIODE,1SS301	AB.....
D	201	87-A40-412-040	0E	C-DIODE,SB05-05CP	AB.....
D	202	87-A40-412-040	0E	C-DIODE,SB05-05CP	AB.....
D	301	87-001-166-080	0E	DIODE,1SS301	AB.....
D	302	87-001-166-080	0E	DIODE,1SS301	AB.....
IC	100	87-A20-707-010	2B	C-IC,CXA2523AR	AB.....
IC	200	87-A20-708-010	2D	C-IC,CXD2652AR	AB.....
IC	203	87-A20-709-040	1H	C-IC,BD7910FV	AB.....
IC	304	87-A20-710-040	1B	C-IC,S-8110AMP	AB.....
IC	303	87-A20-755-080	1B	C-IC,AK93C45AF	AB.....
IC	301	87-A20-837-040	2M	C-IC,NN51V4400ZJ-60	AB.....
IC	300	87-ZG9-601-010	2B	C-IC,CXP81952
IC	300	87-ZG9-605-110	2P	C-IC,CXP81952-521R
IC	301	87-ZG9-606-040	2M	C-IC,MN41V4400SJ-08
IC	300	87-ZG9-607-010	2M	C-IC,CXP81952-****	AB.....
IC	400	87-A20-711-040	1E	C-IC,BA5970FP	AB.....
IC	401	87-A20-712-040	1B	C-IC,BA6417F	AB.....
IC	602	87-A20-714-040	1B	C-IC,NJM2370U33	AB.....
IC	600	87-A20-797-040	1B	C-IC,NJU7221U30	AB.....
IC	603	87-A20-797-040	1B	C-IC,NJU7221U30	AB.....
IC	601	87-A20-798-040	1B	C-IC,NJU7221U35	AB.....
L	101	87-A50-012-080	0E	C-COIL,100UH LQH3C	AB.....
L	100	87-A50-117-080	0E	C-COIL,10UHLQH3C	AB.....
L	102	87-A50-117-080	0E	C-COIL,10UHLQH3C	AB.....
L	103	87-A50-117-080	0E	C-COIL,10UHLQH3C	AB.....
L	203	87-A50-116-080	0E	C-COIL,4.7UHLQH3C	AB.....
L	201	87-A50-117-080	0E	C-COIL,10UHLQH3C	AB.....
L	202	87-A50-117-080	0E	C-COIL,10UHLQH3C	AB.....
L	301	87-A50-117-080	0E	C-COIL,10UHLQH3C	AB.....
L	613	87-005-512-080	0E	C-COIL,BLM21A05	AB.....
L	612	87-005-512-080	0E	C-COIL,BLM21A05	AB.....
L	611	87-A50-163-080	1A	C-COIL,ZBFS5101-PT	AB.....
L	614	87-A50-163-080	1A	C-COIL,ZBFS5101-PT	AB.....
L	616	87-A50-163-080	1A	C-COIL,ZBFS5101-PT	AB.....
L	615	87-A90-034-080	1A	C-FLTR,EMI BLM41P750	AB.....
Q	101	87-026-423-080	0E	C-TR RN2305	AB.....
Q	102	89-115-884-080	0E	CHIP -TRANSISTER 2SA1588Y	AB.....
Q	103	89-341-164-080	0E	CHIP-TRANSISTOR,2SC4116 Y	AB.....
Q	402	87-026-412-080	0E	C-TR RN1305	AB.....
R	425	87-022-583-080	0E	C-RES,U M/F 12K D	AB.....

ELECTRICAL MAIN PARTS LIST - 3/3 (MD: 7ZG-9)

R	426	87-022-583-080	0E	C-RES,U M/F 12K D	AB.....
R	423	87-025-564-080	0E	C-RES,U M/F 47K D	AB.....
R	424	87-025-564-080	0E	C-RES,U M/F 47K D	AB.....
X	200	87-A70-105-080	1B	C-VIB,XTAL 22.5792MHZ SMD-49	AB.....
X	301	87-A70-100-080	1B	C-VIB,CER 12.0MHZ PBRC-BR-A	AB.....

MECHANICAL PARTS LIST - 1/1

NOTE: The characters in the suffix column indicate the part usage.

REF.NO	PARTS NO.	NO.	DESCRIPTION	SUFFIX
U		XX		A
		KANRI		
	8Z-CC3-001-010		CABI,FR MD	.B
	8Z-CC3-002-010		PANEL,REAR MD	.B
	8Z-CC3-003-010		RING,MD	AB
	8Z-CC3-006-010		PLATE,DISC	AB
	8Z-CC3-007-010		BADGE,AIWA 27.5 ABS SIL	AB
	8Z-CC3-008-010		CABI,FR MD (U)	A
	8Z-CC3-009-010		PANEL,REAR MD (U)	A
	8Z-CC3-010-010		PANEL,REAR MD (Y)	
	8Z-CE3-005-010		PANEL,TOP	.B
	8Z-CE3-006-010		FOOT,DIA40 H4	AB
	8Z-CE3-007-010		REFLECTOR,FR	AB
	8Z-CE3-018-010		PANEL,TOP (U)	A
	8Z-CF3-002-010		PANEL,SIDE L LOW	.B
	8Z-CF3-003-010		PANEL,SIDE R LOW	.B
	8Z-CF3-012-010		PANEL,SIDE L LOW (U)	A
	8Z-CF3-013-010		PANEL,SIDE R LOW (U)	A
	8Z-CC3-004-010		KEY,PLAY MD	AB
	8Z-CC3-005-010		KEY,UP DOWN	AB
	88-CE2-209-010		SPR-T,MD	AB
	8Z-CC3-203-010		CHAS,MAIN MD (U)	A
	8Z-CE3-202-010		GUIDE,LED CNT	AB
*	8Z-CF3-203-010		PLATE,TOP TUNER	AB
	8Z-CC3-202-010		GUIDE,MD	AB
	87-067-689-010		TAPPING SCREW, BVTT+3-8	AB
	87-067-703-010		TAPPING SCREW, BVT2+3-10	AB
	87-067-761-010		TAPPING SCREW, BVT2+3-10	AB
	87-078-060-010		BVIT3PB+3-10	AB
	87-721-096-410		QT2+3-10 GLD	AB
*	87-B10-230-010		BVT2+3-10 W/O SLOT SILVER CR	AB
	87-A91-438-010		BUSHING,CABLE19P-1.5 SMK	AB
CNA	0	8Z-CC3-606-010	CONN ASSY,19P 52305-1914	AB
W	0	88-904-261-110	FF-CABLE, 4P 1.25 260MM	AB
W	0	8Z-CC3-607-010	FF-CABLE, 14P 1.0 100MM	AB
W	0	8Z-CC3-608-010	FF-CABLE, 8P 1.0 100MM	AB

MECHANICAL PARTS LIST - 1/1 (MD: 7ZG-9)

NOTE: The characters in the suffix column indicate the part usage.

REF.NO	PARTS NO.	KANRI NO.	DESCRIPTION	SUFFIX
B1		XX		A
	87-067-020-010	0E	SCREW, VTT+3-4	AB
	87-067-421-010	0E	VTT+2-4	AB
	87-ZG9-208-010	0E	S-SCREW,MD T	AB
	87-ZG9-209-010	0E	S-SCREW,MD TF	AB
	87-ZG9-201-110	1C	HLDR,SHLD BOT	AB
	87-ZG9-202-110	1C	HLDR,SHLD TOP	AB
	87-ZG9-602-010	1B	FF-CABLE, 21P 0.5 90MM	AB
	87-ZG9-603-010	0E	FF-CABLE, 8P 1.0 120MM	AB
	87-ZG9-604-010	0E	FF-CABLE, 5P 1.25 100MM	AB

ACCESSORIES/PACKAGE LIST-1/1

NOTE: The characters in the suffix column indicate the part usage.

REF.NO	PARTS NO.	NO.	DESCRIPTION	SUFFIX
	87-B30-024-010		CABLE,OPTICAL MC-901	A.....

SCHEMATIC DIAGRAM

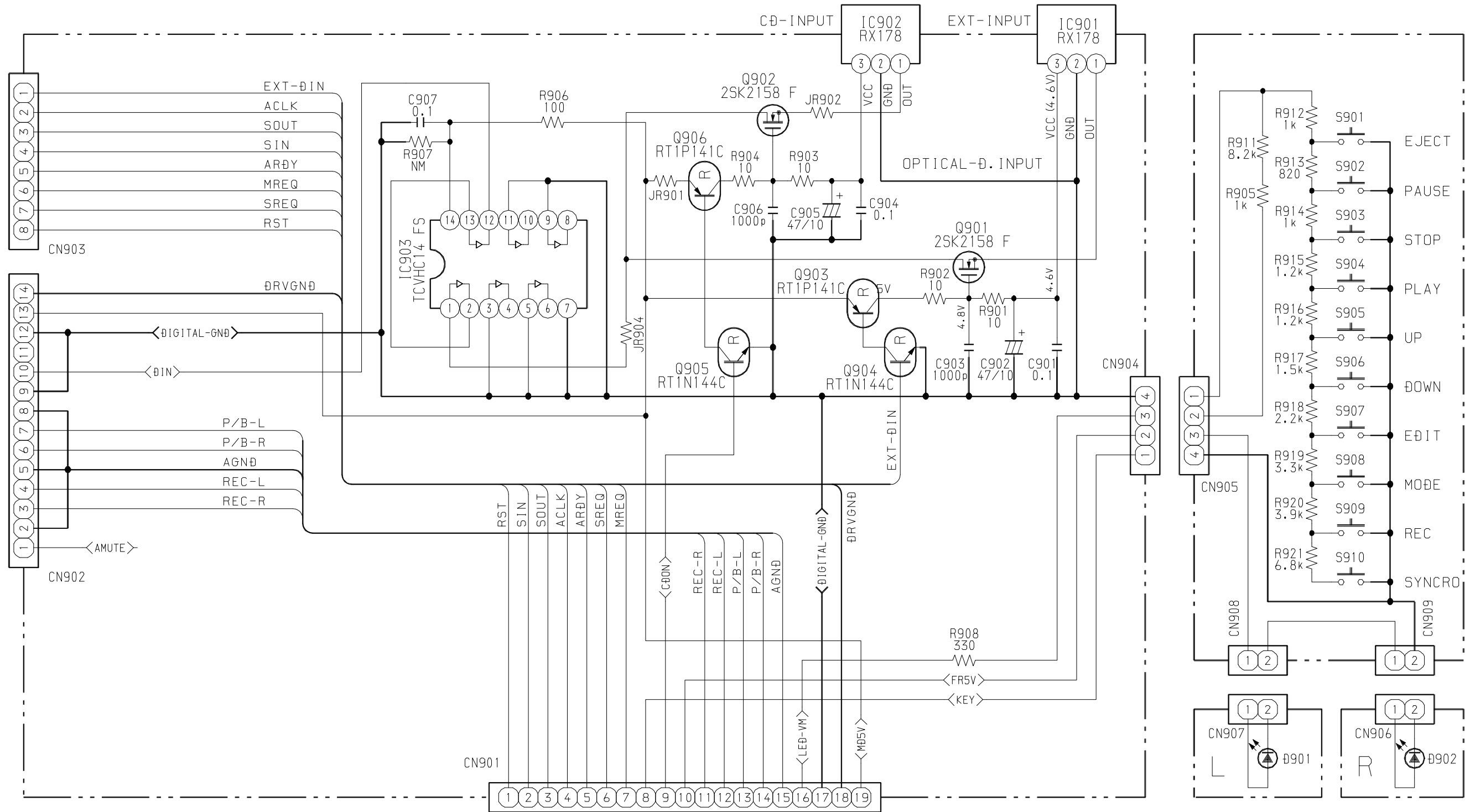

B.Ø.KIM

MØ

8Z CC3 601 01

VEE	21
E	20
D	19
C	18
F	17
J	16
VC	15
A	14
B	13
J	12
VCC	11
LB-GND	10
ILCC	9
MOD	8
VR	7
PD	6
PD-K	5
FCS+	4
FCS-	3
TRK+	2
TRK-	1

SL+	8
SP+	7
SL-	6
SP-	5
LS	4
COM	3
RFLECT	2
BISCPRO	1

EXTBIN	8
ACLK	7
SOUT	6
SIN	5
ARBY	4
MREQ	3
SREQ	2
SRST	1

AMUTE	14
AGND	13
A1NR	12
A1NL	11
AGND (IN)	10
ADUTR	9
ADUTL	8
AGND (OUT)	7
GND	6
BIN	5
BOUT	4
GND	3
VIN	2
BRVGN	1

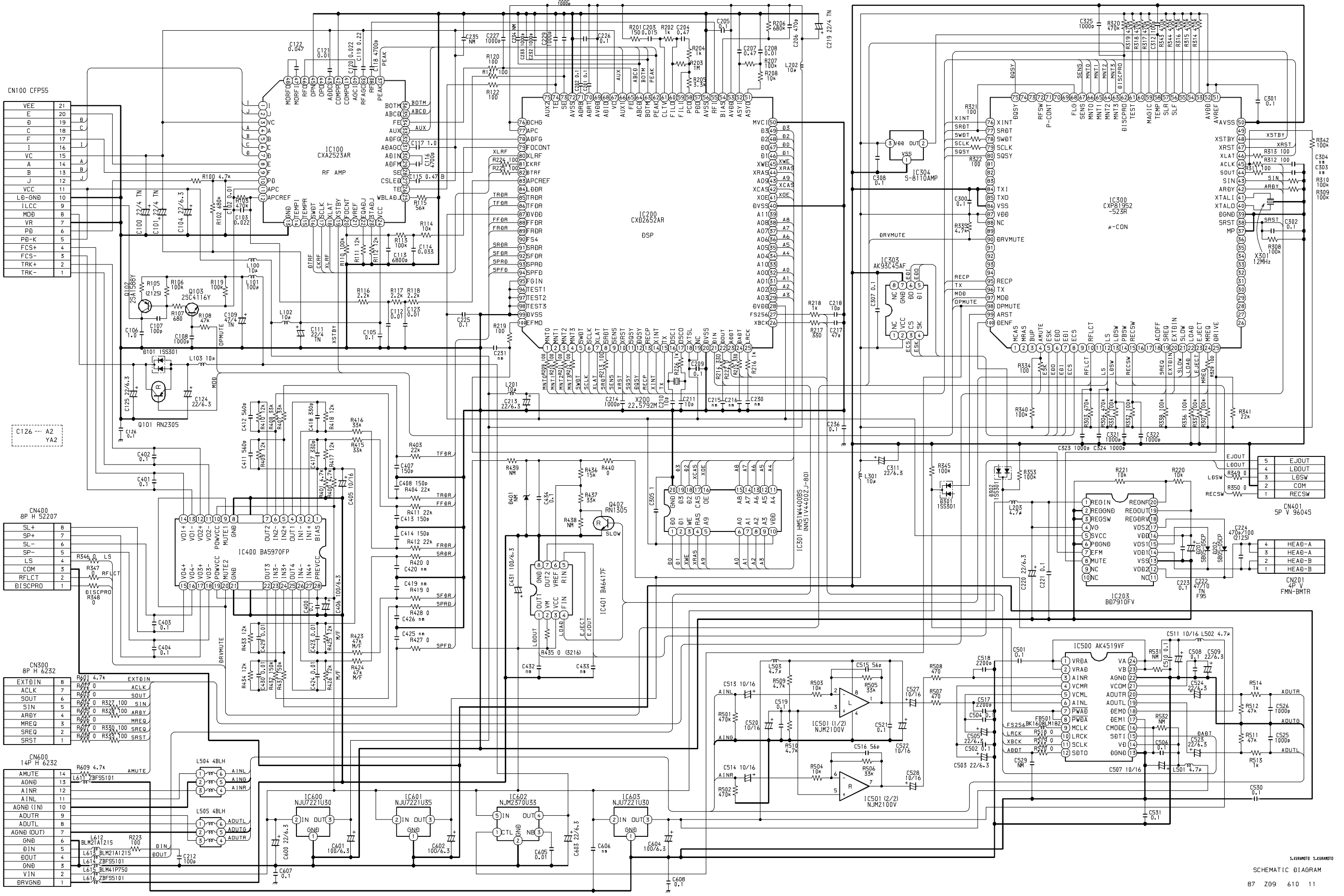

サービス技術ニュース	
番号	連絡内容
G- -	
G- -	
G- -	

アイワ株式会社
AIWA CO.,LTD.

9820572

Tokyo Japan