

DIRECT DRIVE STEREO TURNTABLE SYSTEM

MODEL AP-2200H,EE,UK

AIWA®

(SERVICE MANUAL)



Set using ISO screws

DATE OF ISSUE 26/10/1977

SPECIFICATIONS

Type:	Direct drive stereo turntable system	Maximum acceptable cartridge-headshell weight:	21.5 g (including head shell)
Circuitry:	2 ICs, 8 transistors, 14 diodes		
Power supply:	AP-2200 H,EE AC110-120V/220-240V 50/60 Hz	CARTRIDGE (H,UK model only)	
	AP-2200UK AC120V/240V 50/60 Hz	Type:	Moving Magnet
Power Consumption:	6W	Output:	3 mV (1 kHz)
Dimensions:	424W x 123H x 359D mm	Separation:	20 dB (33-1/3 r.p.m. 1 kHz)
Weight:	6.9 kg	Stylus:	0.5 mill diamond
TURNTABLE		Tracking pressure:	2 grams (1.7 – 2.3 grams allowable)
Type:	Direct drive type	Frequency response:	20 – 20,000 Hz
Motor:	2-phase, 8-pole, slotless Hall-effect motor	Compliance:	15 x 10 ⁻⁶ cm/dyne
RPM:	33-1/3, 45 r.p.m.	Loading capacitance:	100pF
RPM range:	±3% (33-1/3 r.p.m.)	Load impedance:	50 k ohms
Platter:	Die-cast aluminum, 306 mm diameter		
S/N ratio:	70 dB (DIN B curve) above 60 dB (IEC B curve)		
Wow/flutter:	Less than 0.035% (WRMS)		
TONEARM			
Type:	Static balanced		
Overhang:	15 mm		
Tracking error:	+6.3°, +0.8°		
Off-set angle:	21.5°		
Stylus pressure range:	0 – 3 g		
Acceptable cartridge weight:	3.5 – 11 g		

* Specifications and design are subject to change without notice.

DISASSEMBLY INSTRUCTIONS

To Remove Main Gear
Remove mounting E-ring

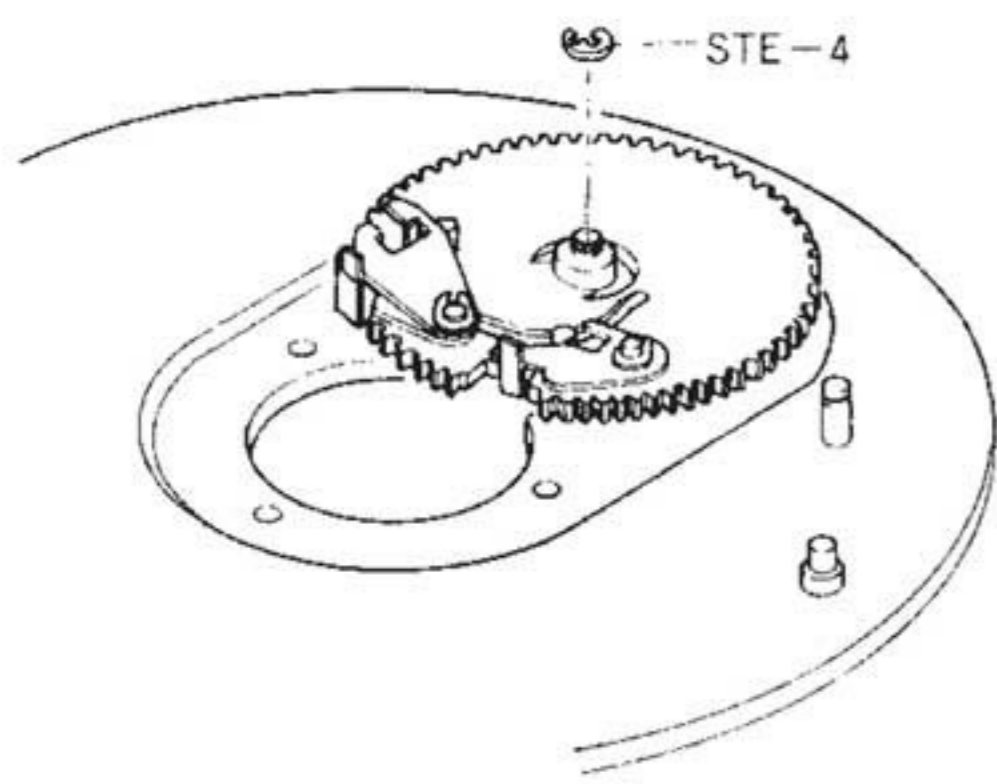

3) Remove 2 setscrews and 1 nut.

Tone arm Ass'y

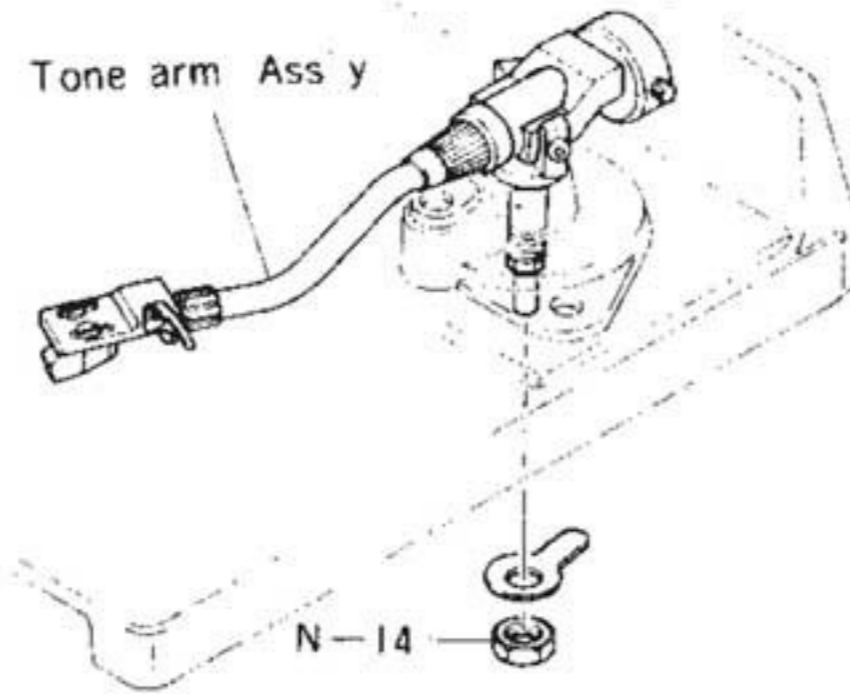

SSH2.6-4

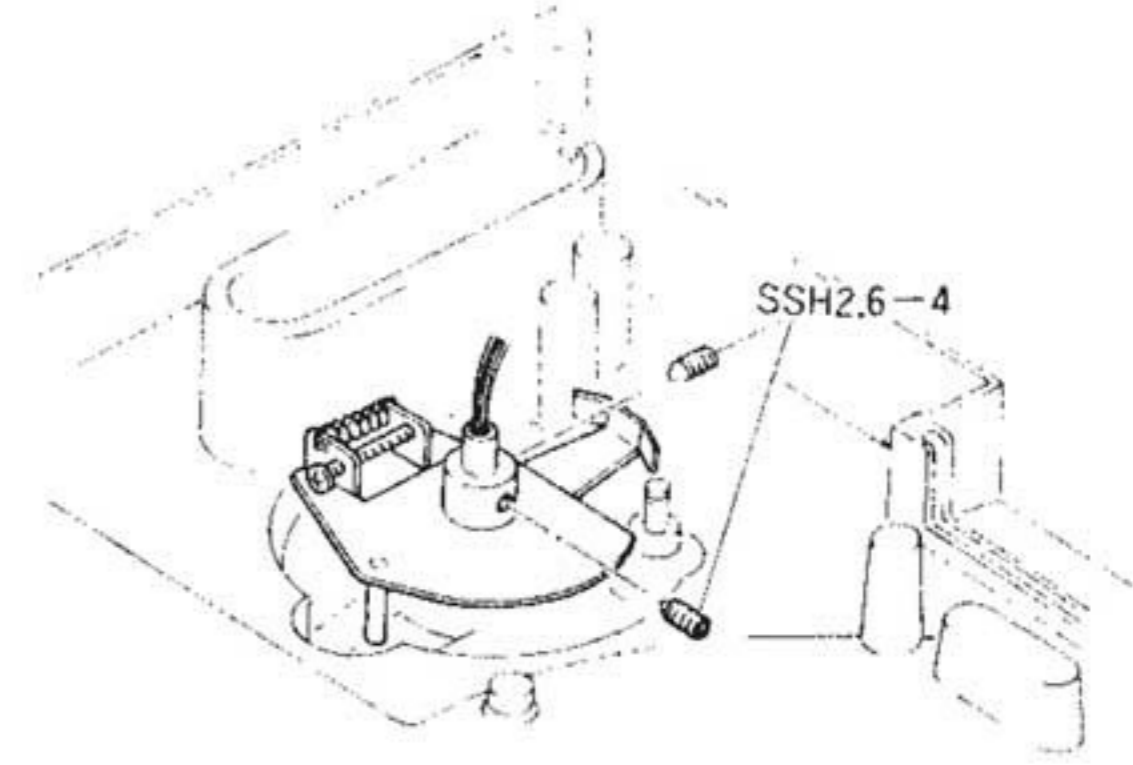

To Remove Bottom Cover
Remove 10 screws.

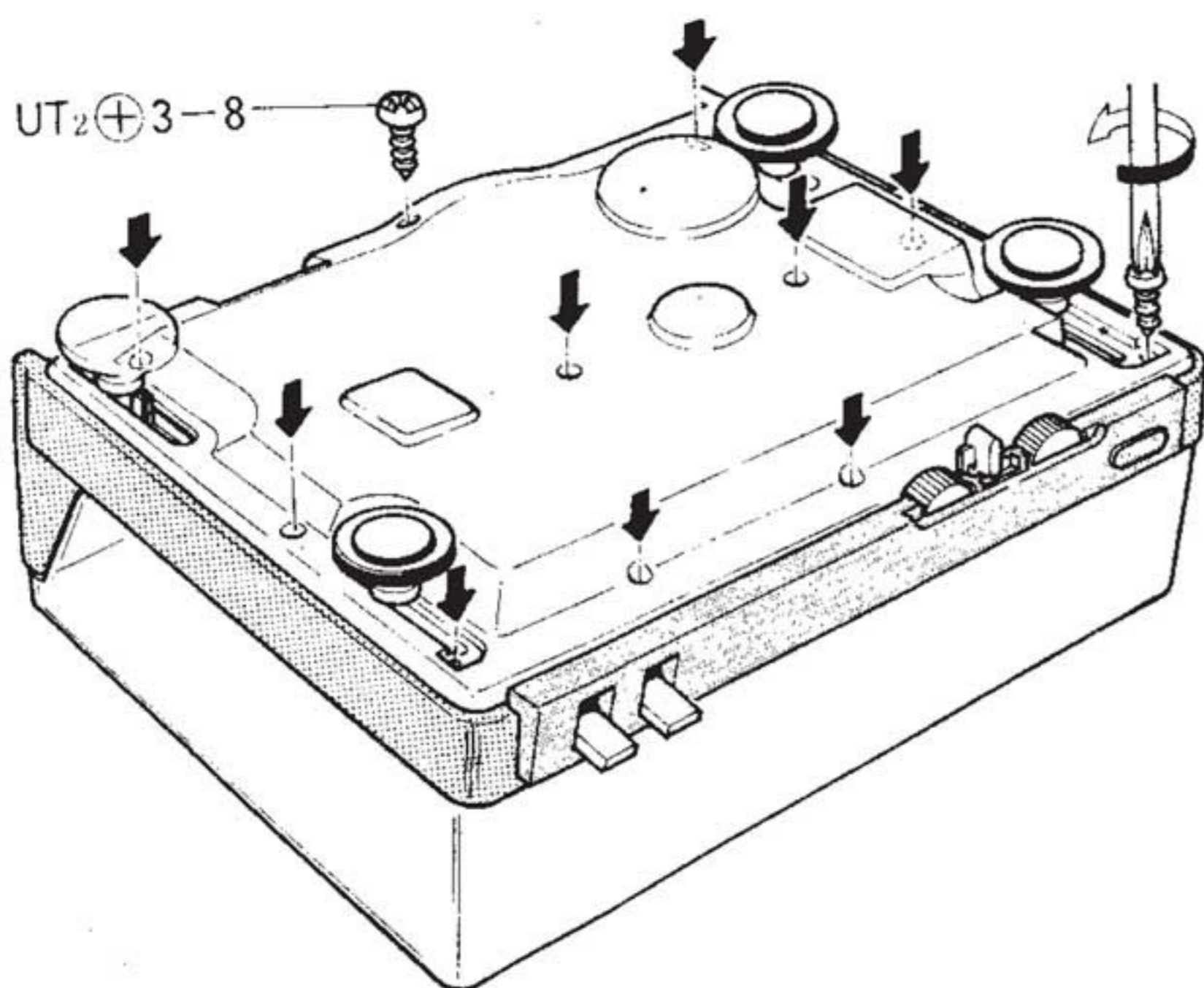

2) Remove the syncrate shaft and mounting nut.

Syncrate shaft

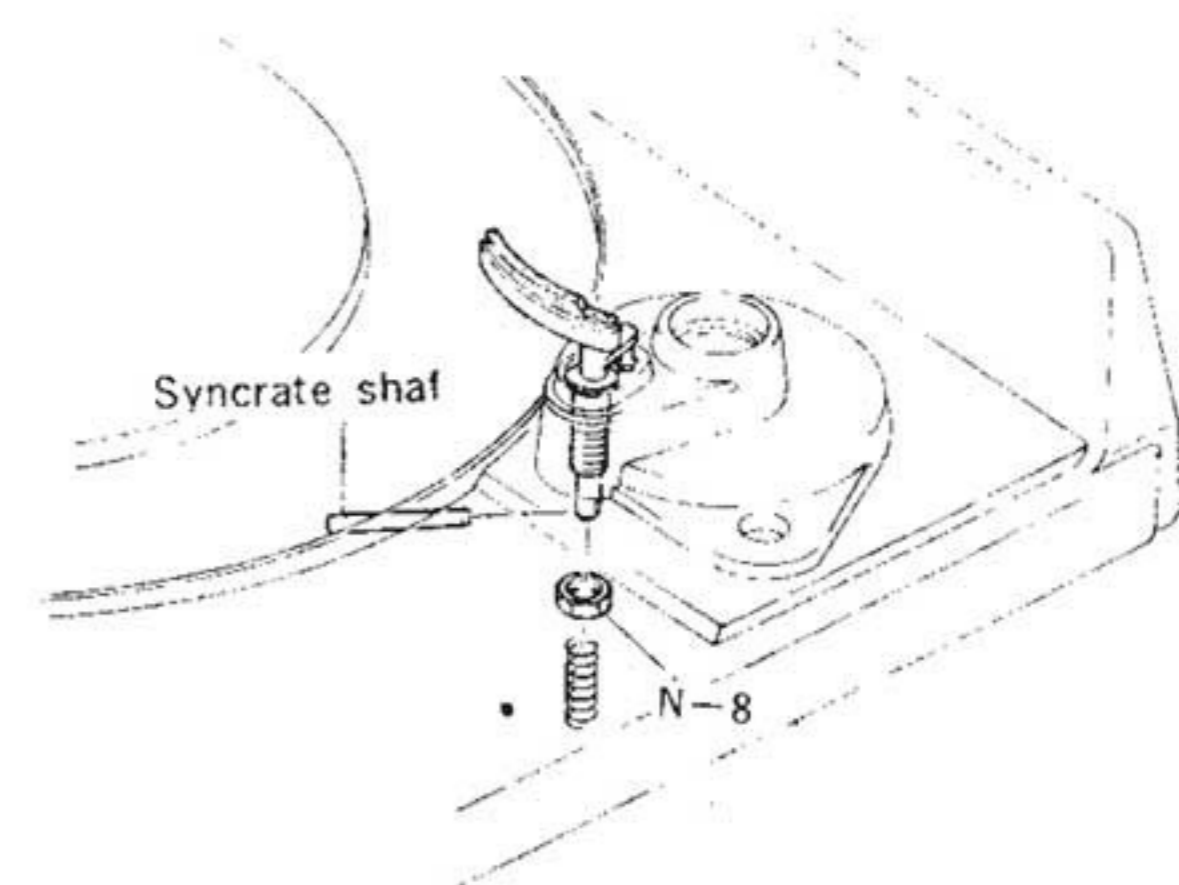

2) Remove mounting E-ring.

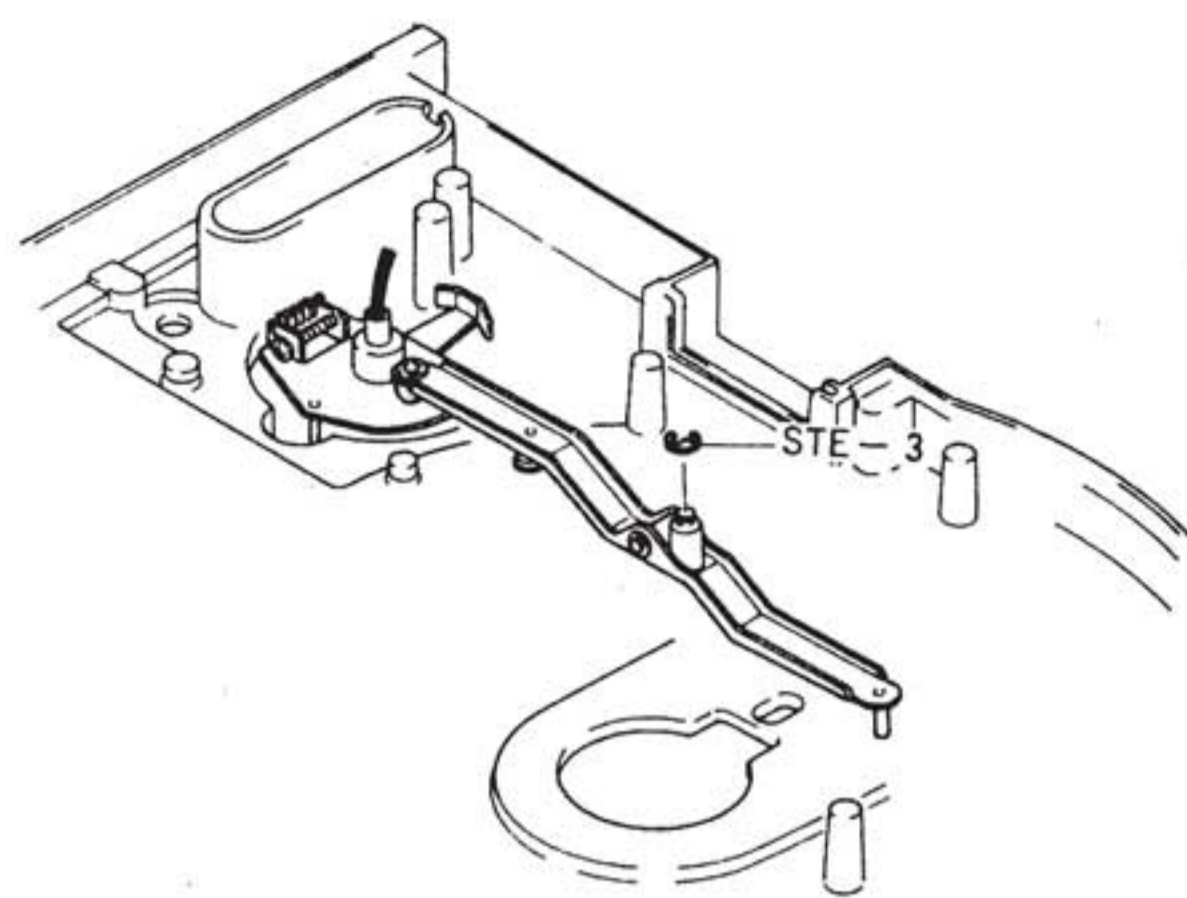

To Remove Tonearm

1) Remove mounting screw and disconnect 4 tonearm leads from the signal circuit board with a soldering iron.

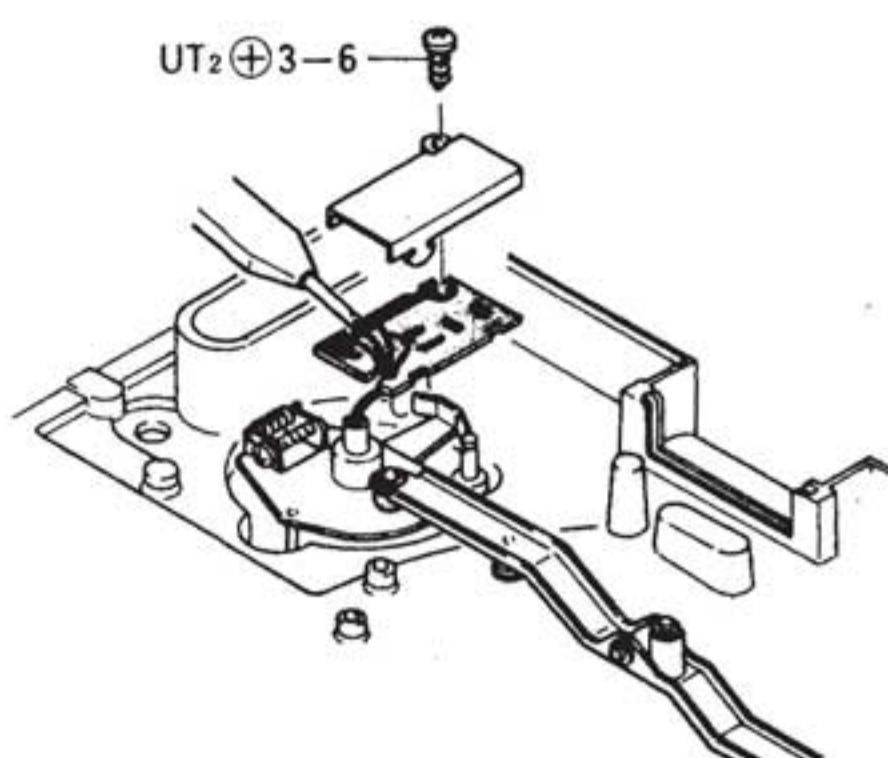

To Remove Micro Switch (Return)
Remove mounting screw.

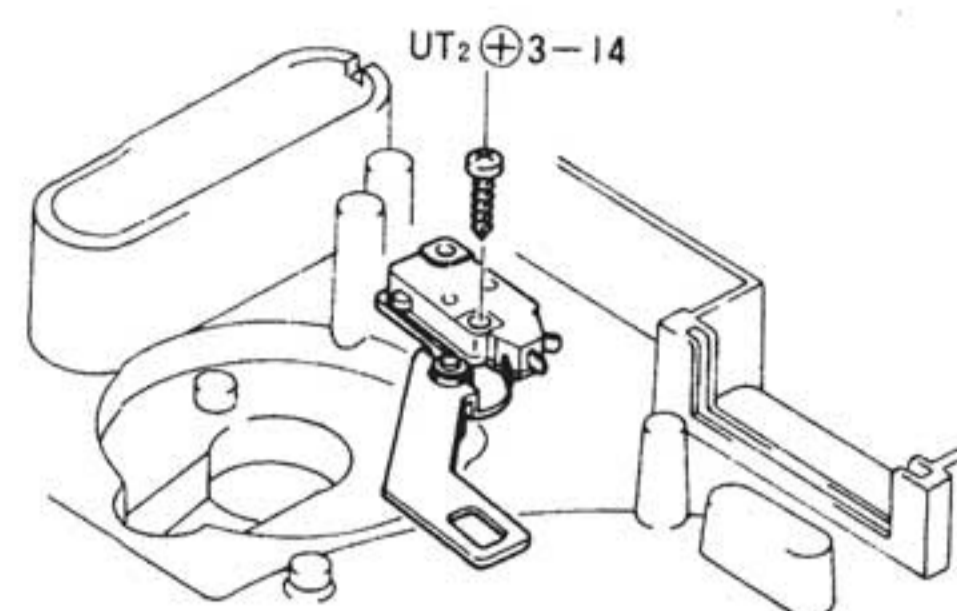

To Remove Power Circuit Board
Remove 3 screws.

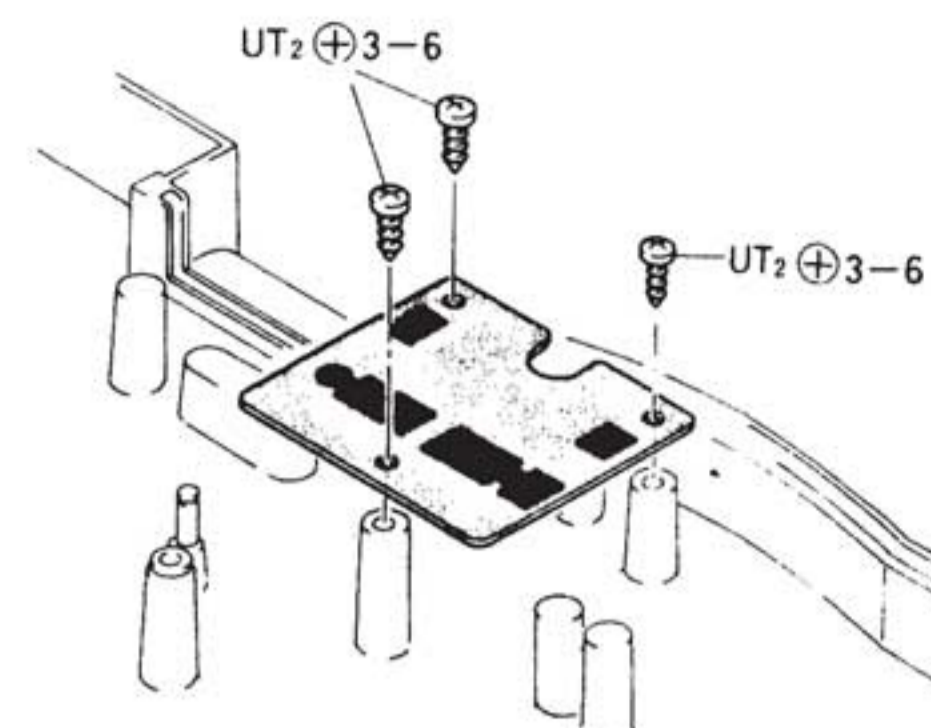

To Remove Motor
Remove 4 screws.

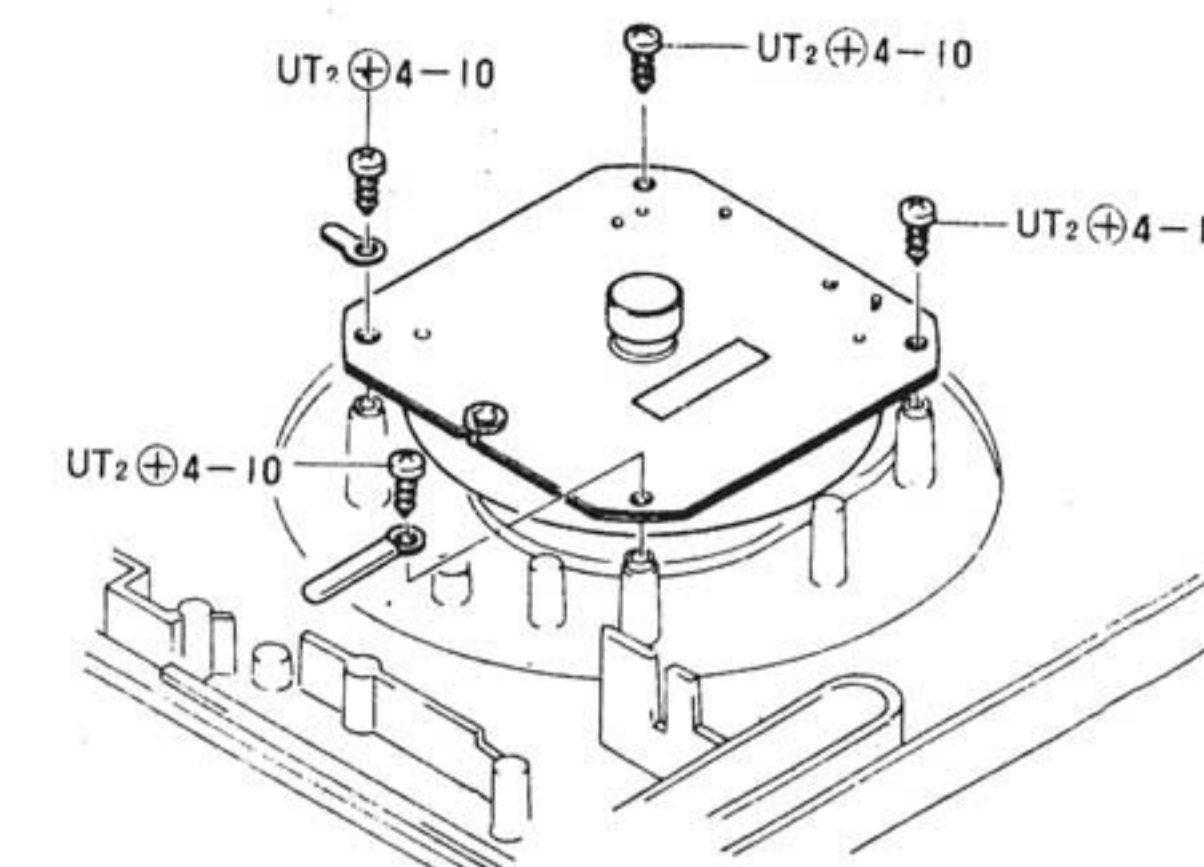

To Remove REC/SYNC Switch
Remove 4 screws.

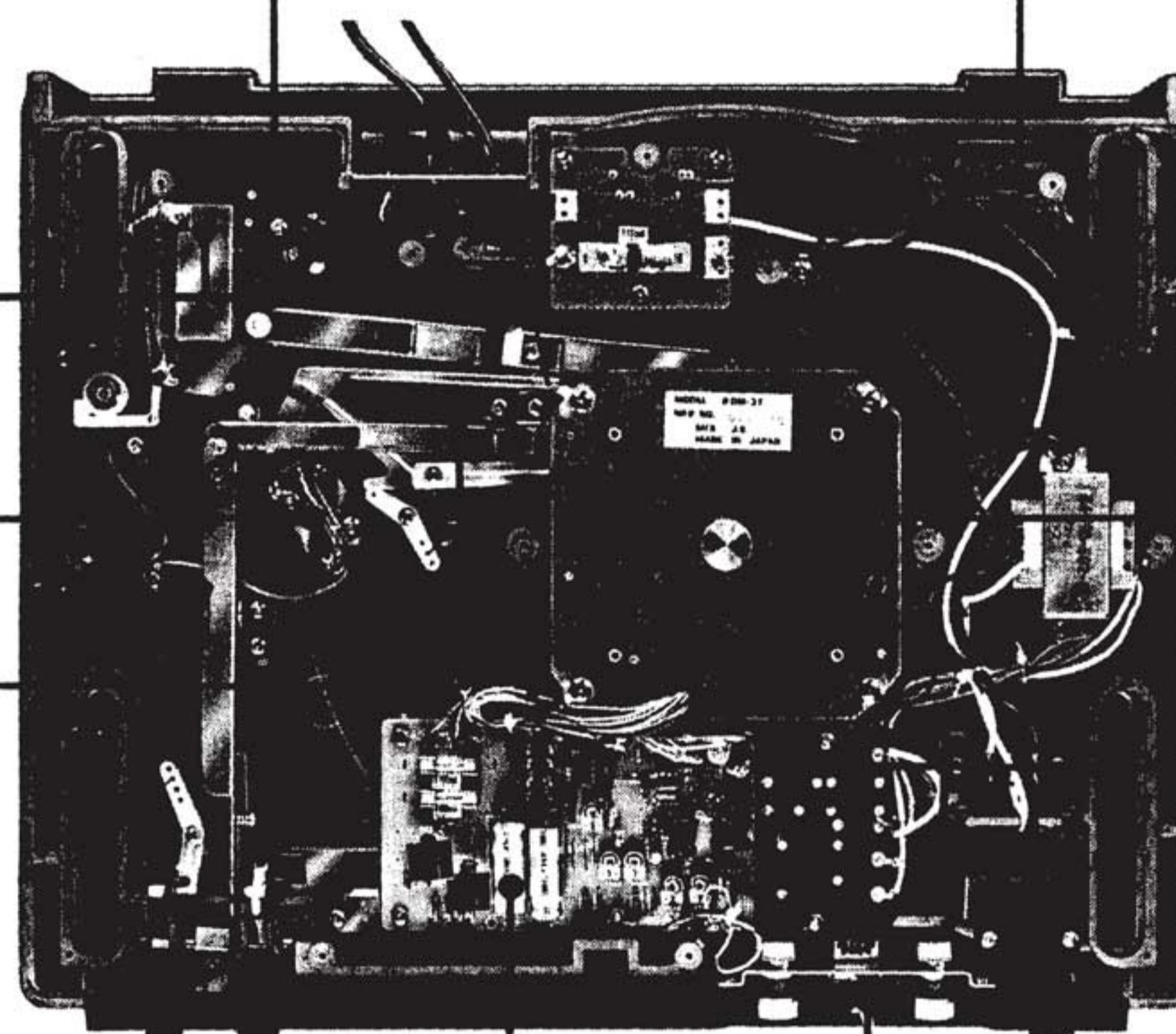
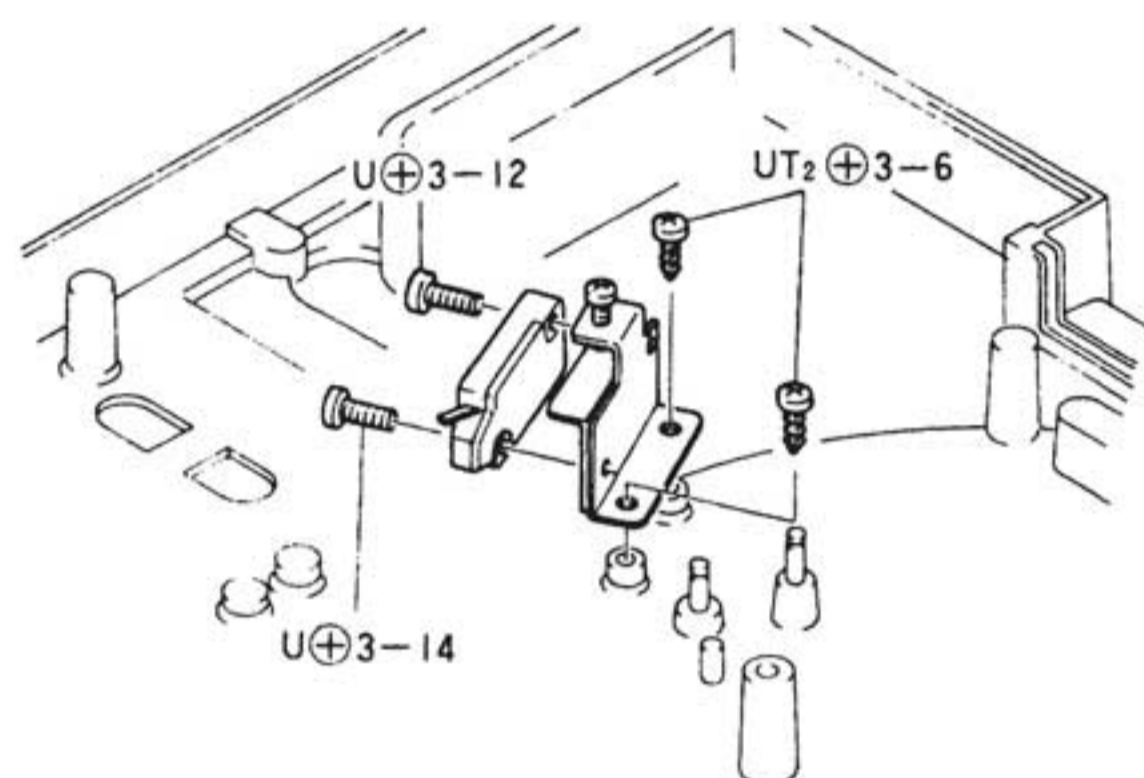

To Remove Strobe Circuit Board (A)
Remove 2 screws.

To Remove Strobe Circuit Board (B)
Remove 2 screws.

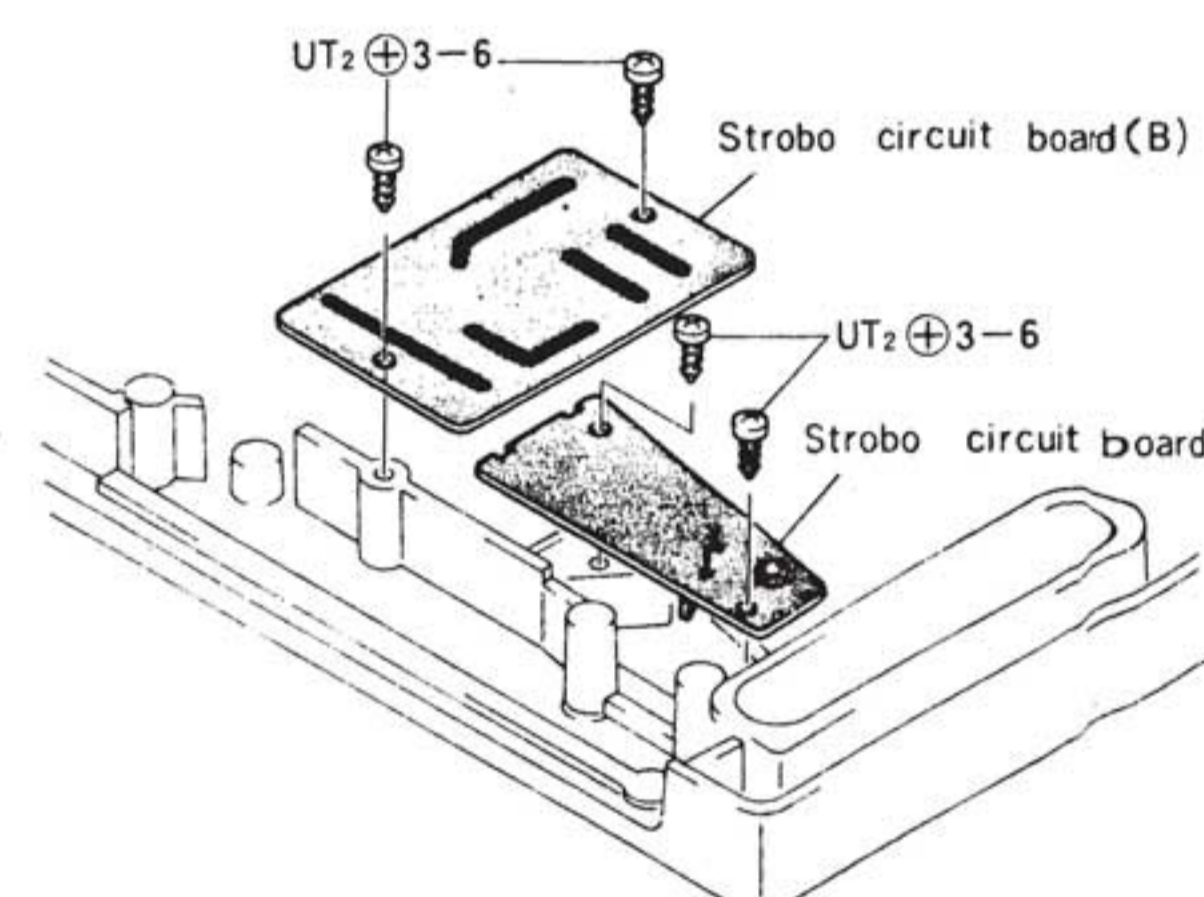

To Remove Speed Adjust Volume and Speed Selector Switch

1) Remove 3 screws.

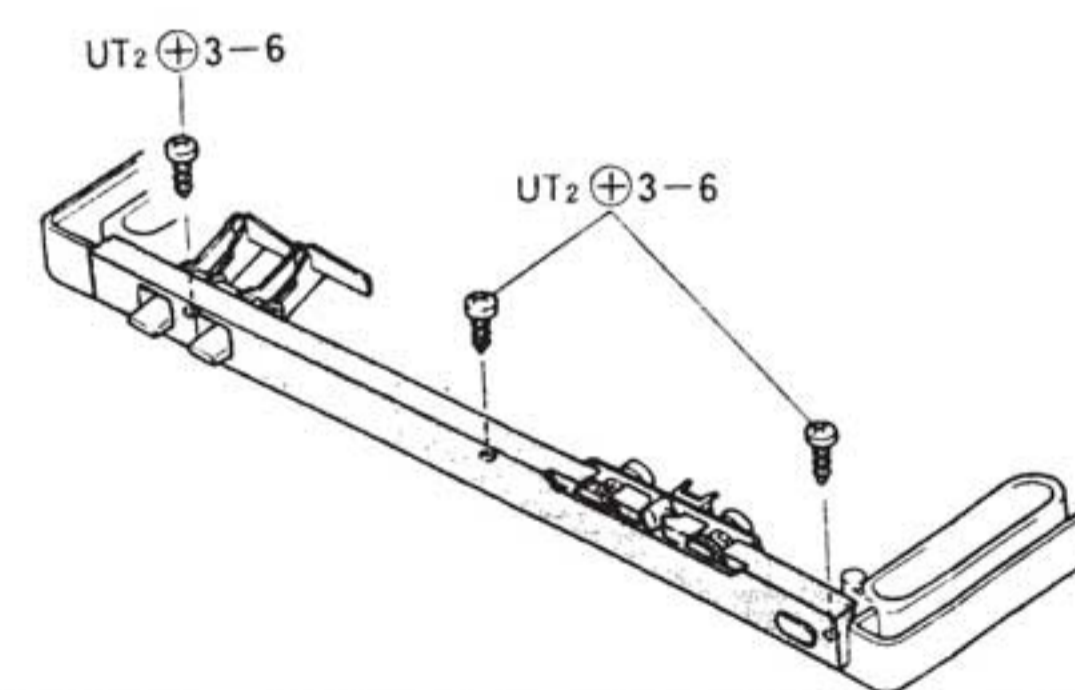

To Remove Elevation Plate

1) Remove 4 screws

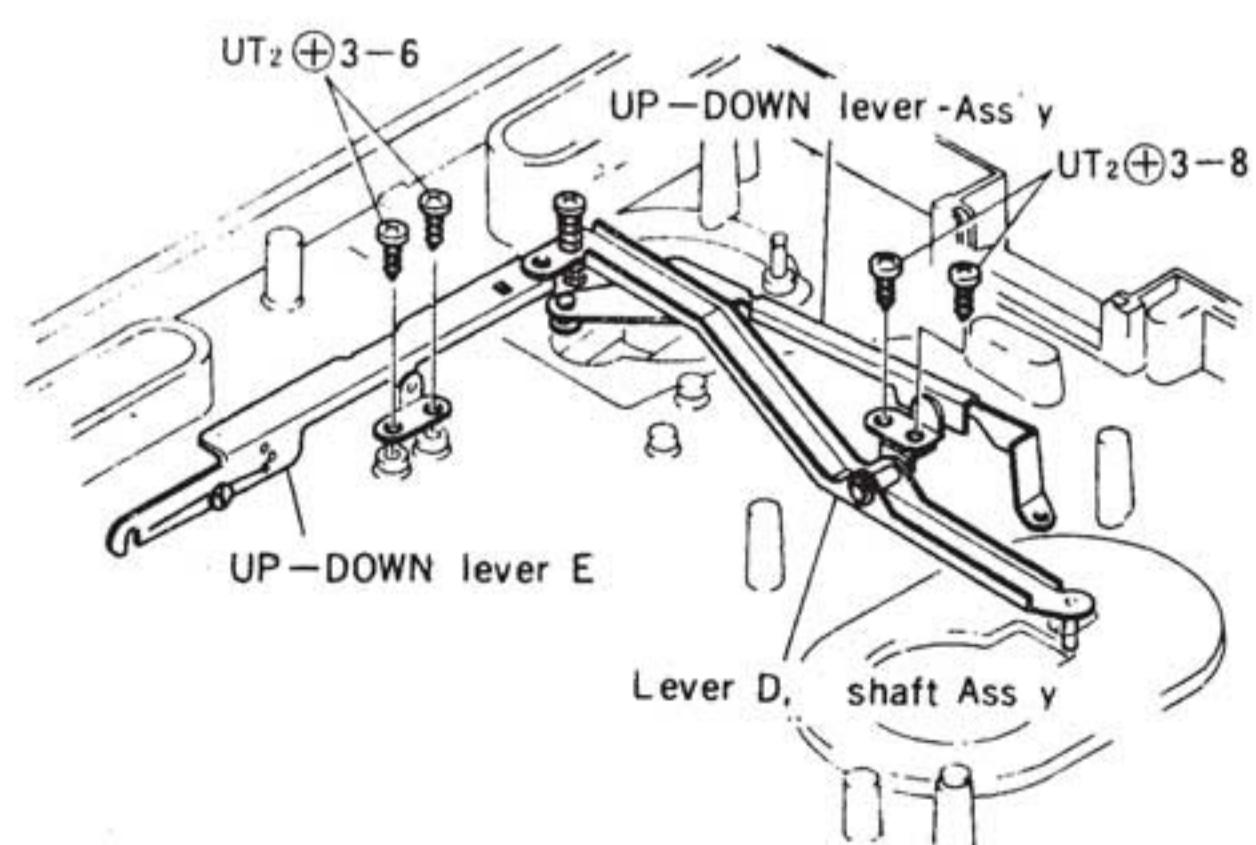

To Remove Motor Circuit Board
Remove 4 screws.

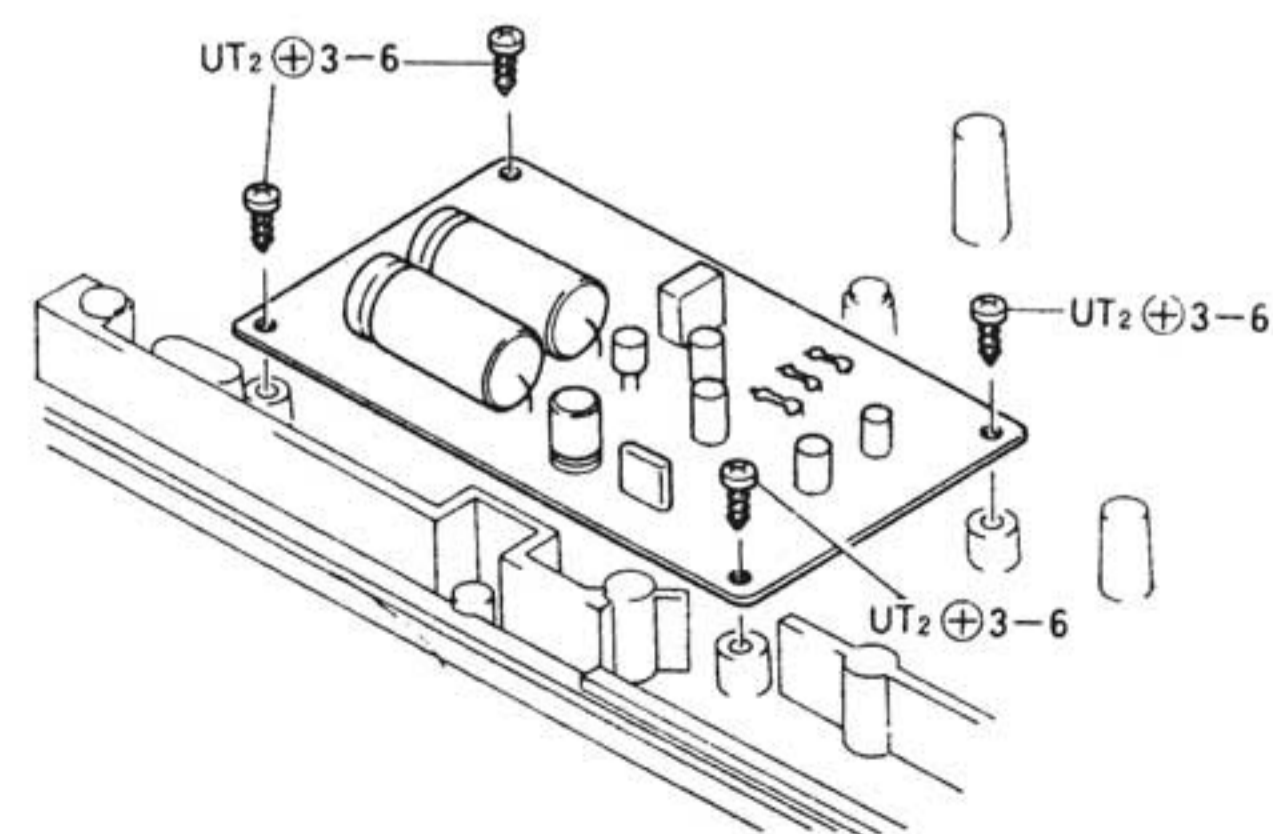

4) Remove 2 screws and 2 nuts.

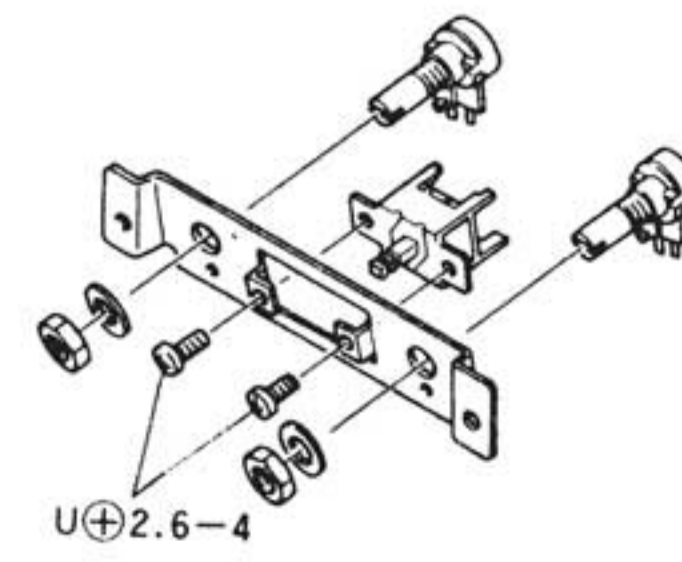

3) Remove 3 knobs.

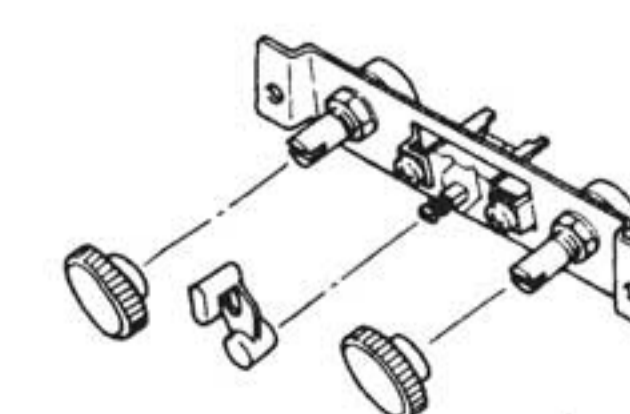

2) Remove 2 screws.

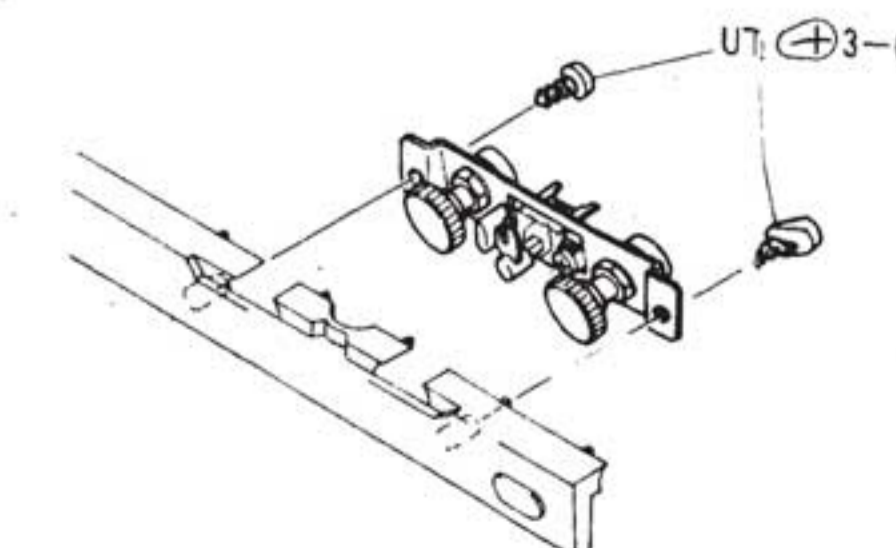

ADJUSTMENTS

1. Adjusting the height position of the stylus at UP/DOWN

Proceed to adjust as outlined below so that the clearance between the record and stylus is 5 ± 1 mm.

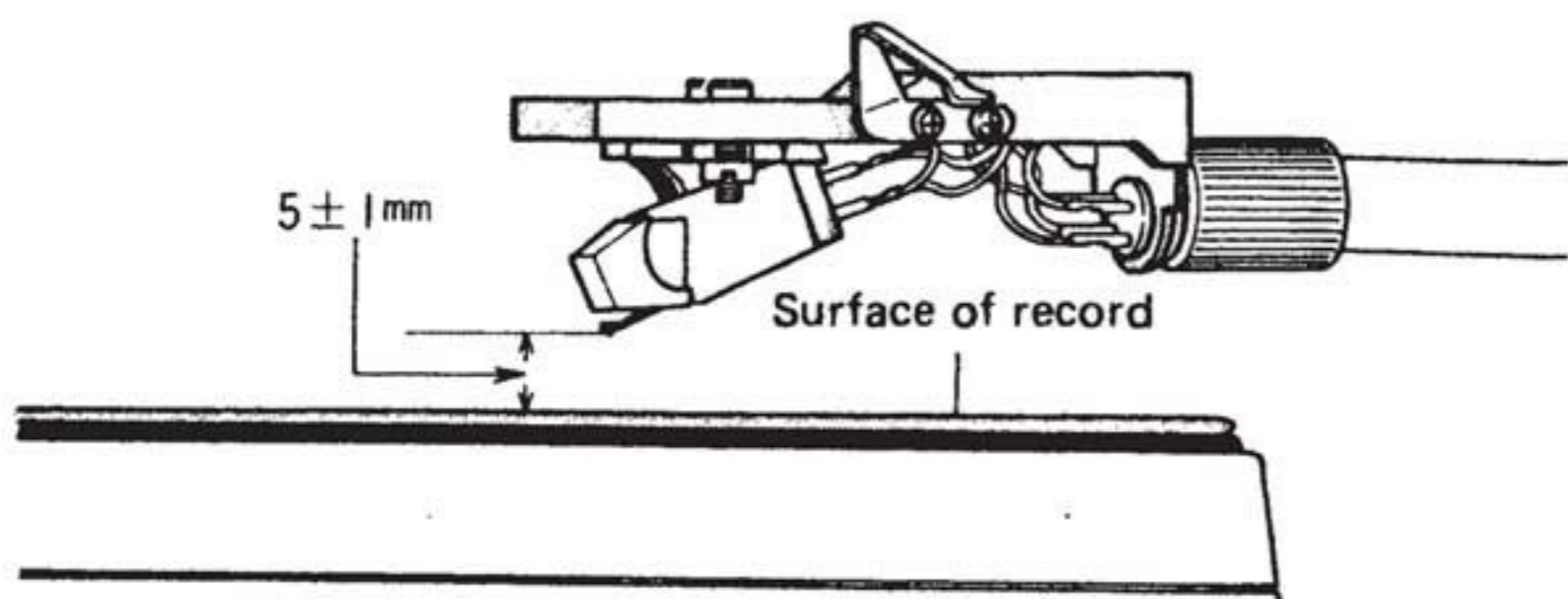

- 1) Set the turntable to the play mode, and adjust the thrust adjust screw so that the clearance between the record and the stylus is 4.5 mm when the tonearm is raised manually.
- 2) After the record has been played (turntable is now set to the stop mode), check that the clearance between the record and the stylus is 5 ± 1 mm. If, after checking, the clearance is found to be less or more than this value, turn the thrust adjust screw to the left or right, and adjust for a 5 ± 1 mm clearance.

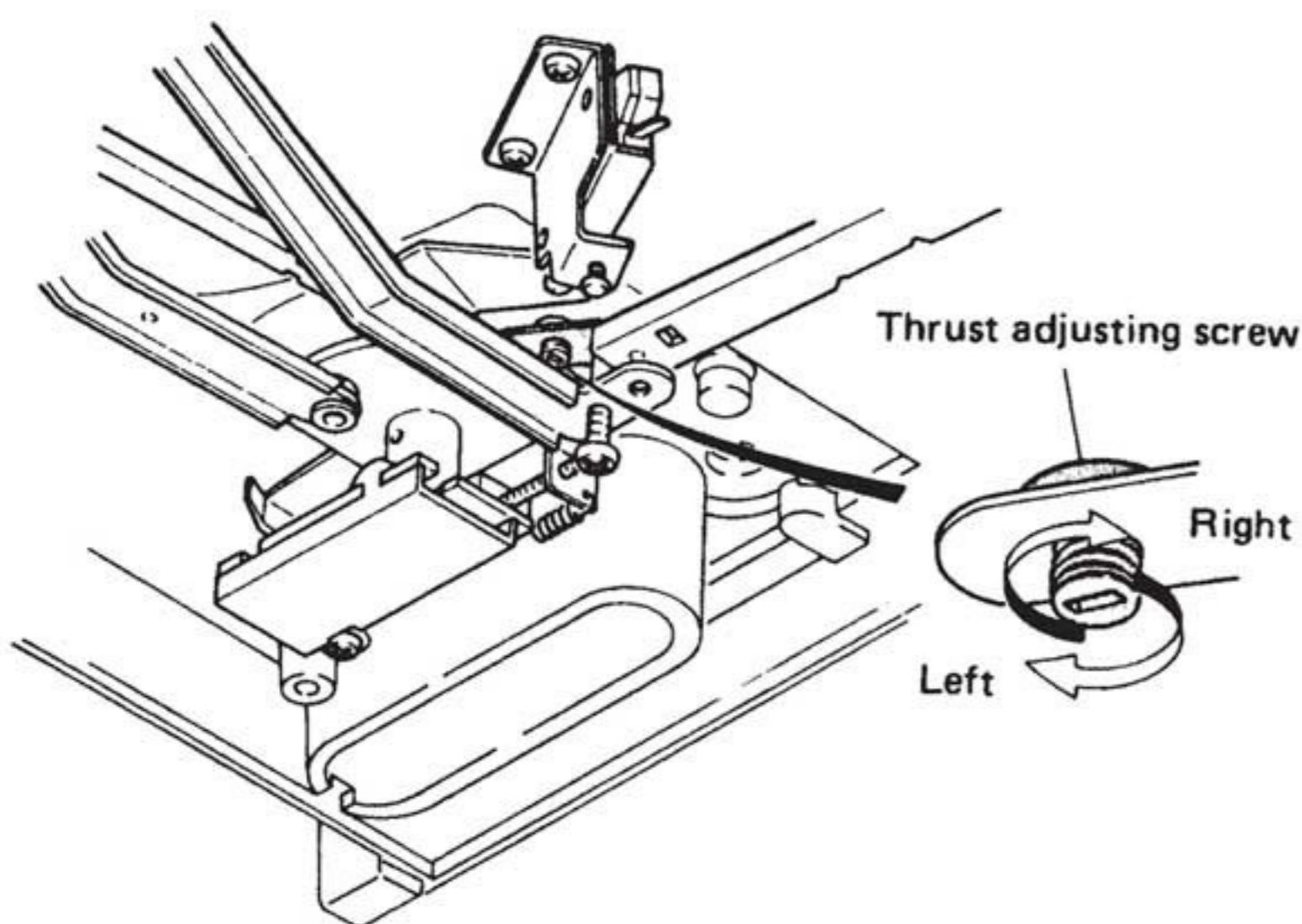

Note: Turning the thrust adjust screw has the following effects:

- Turning it to the right raises the tonearm.
 - Turning to the left lowers the tonearm.
- 3) After carrying out the adjustment under step 2, adjust the clearance between the syncrate shaft and the up/down lever adjust screw to 0 mm.

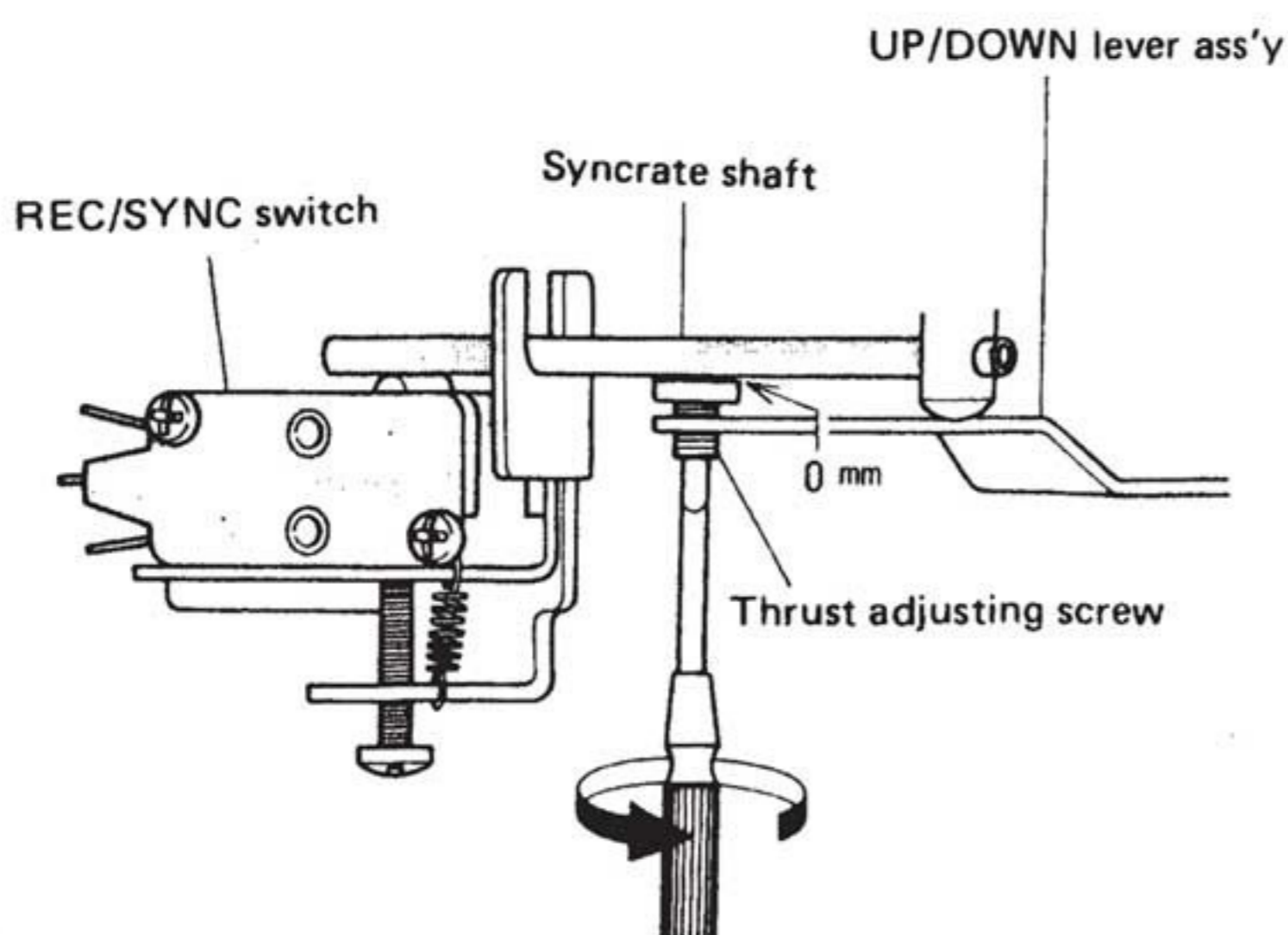

2. Auto adjustment

Proceed to adjust as outlined below if the automatic operation is faster or slower than its specification.

- 1) If the automatic operation is faster, turn the lever F (auto) assembly adjust screw to the left, and adjust.
- 2) If the automatic operation is slower, turn the lever F (auto) assembly adjust screw to the right, and adjust.

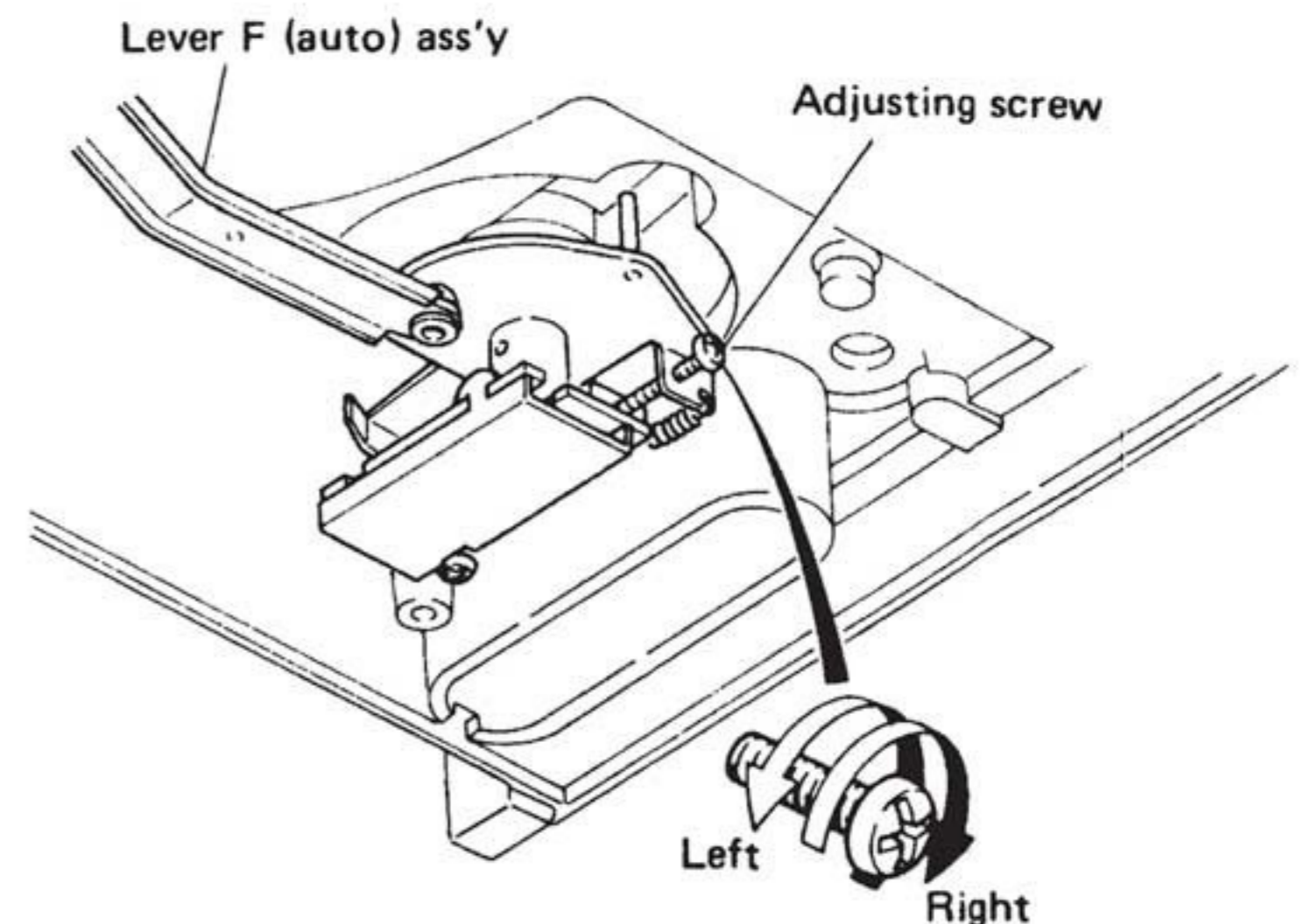

3. Sync rate adjustment

Proceed to adjust the syncrate operation as outlined below so that the clearance between the record and the stylus is 1-2 mm.

- 1) Detach the bond lock of the syncrate plate D, loosen the screw underneath the microswitch, turn the adjust screw to the left or right and adjust.
 - * Turn the screw to the left if the syncrate operation is faster.
 - * Turn the screw to the right if the syncrate operation is slower.

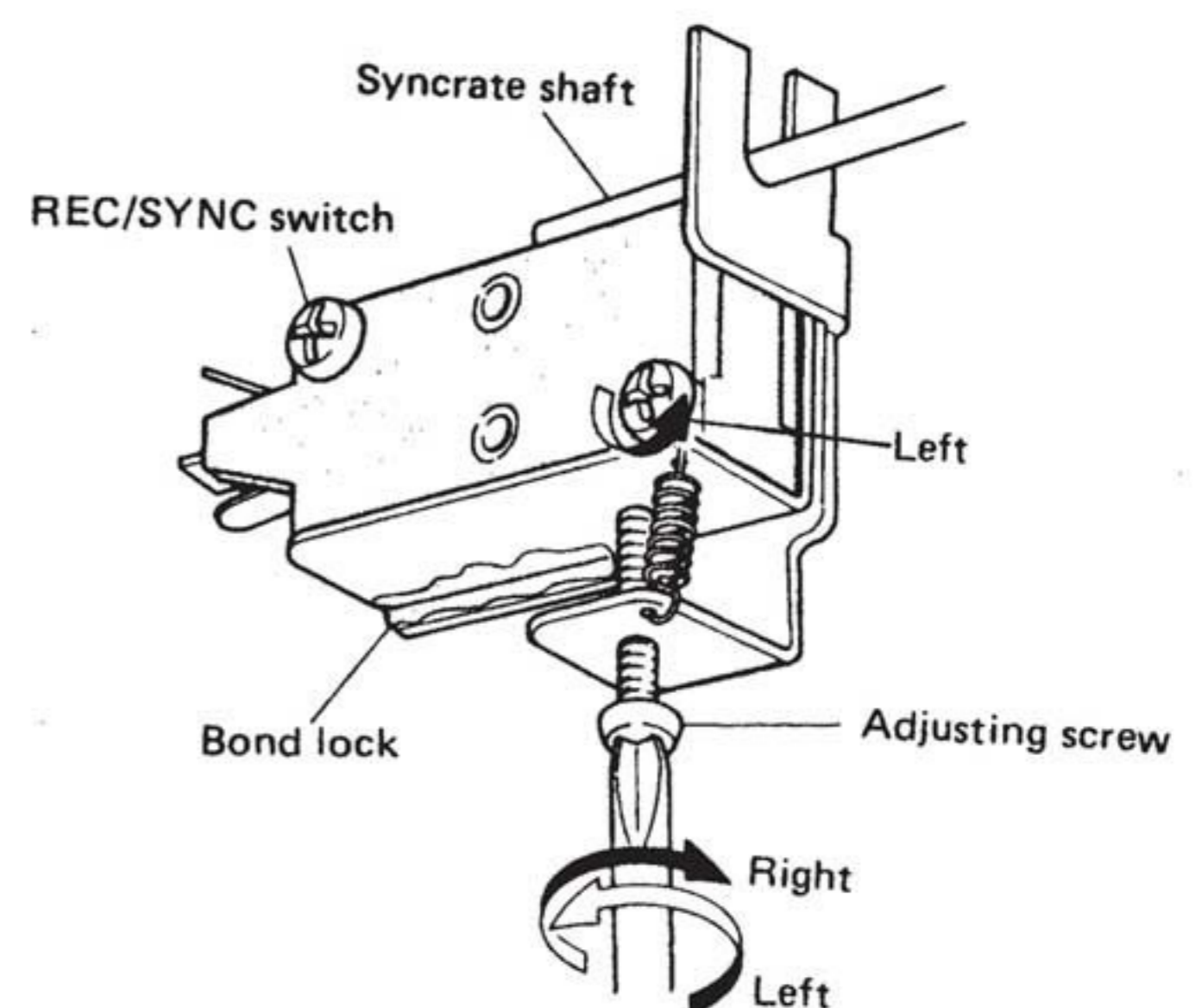

EXPLODED VIEW-1

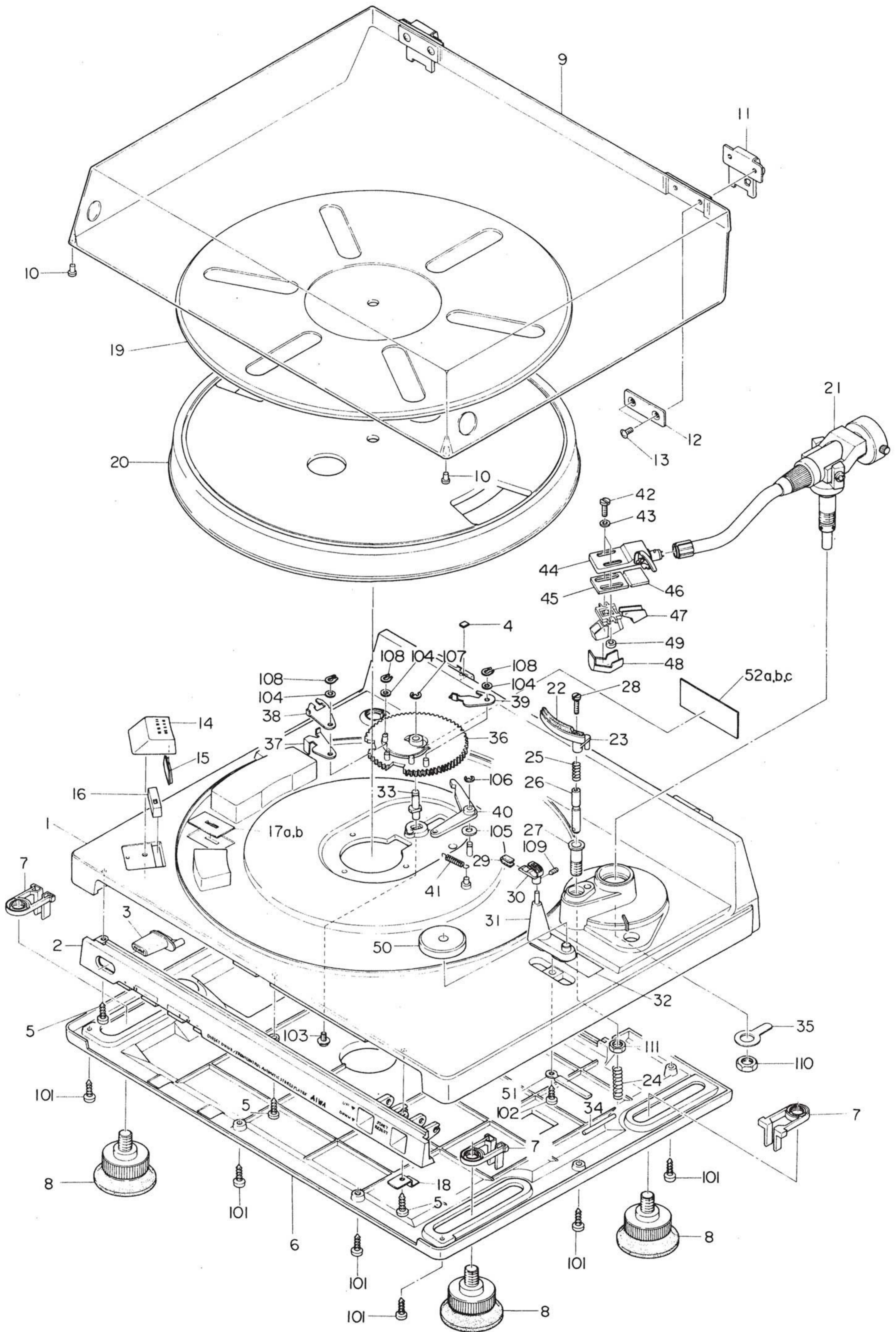

PARTS LIST

MECHANICAL PARTS

■ * mark in this part list shows exclusive part (which is used) for only Model A P-2200.

Ref. No.	Part No.	Part No. Changed to	Description	Common Model	Q'ty
1-1	84-190-089-01		Main cabinet S	*	1
1-2	84-190-088-01		Front panel	*	1
1-3	84-190-082-01		Push button, POWER	*	1
1-4	84-190-291-01		Spacer, Hinge	*	1
1-5	87-341-019-01		UT ₂ + 3-6		3
1-6	84-190-190-01		Bottom cabinet	*	3
1-7	84-190-247-01		Slide plate	*	4
1-8	84-190-014-01		Insulator ass'y	*	4
1-9	84-190-005-01		Dust cover	*	1
1-10	84-184-092-01		Dumper		2
1-11	84-190-019-01		Hinge ass'y	*	2
1-12	84-190-020-01		Hinge plate	*	2
1-13	87-222-170-01		P + 4-8		4
1-14	84-190-091-01		Holder B, Strobo S	*	1
1-15	84-190-009-01		Cover, Strobo	*	1
1-16	84-190-063-01		Reflector board	*	1
1-17a	84-190-083-01		Label, Voltage selector (H,EE model only)	*	1
1-17b	84-190-084-01		Label, Voltage selector (UK model only)	*	1
1-18	84-190-293-01		Holder, M push-key	*	1
1-19	84-190-004-01		Sheet, Turntable	*	1
1-20	84-190-003-01		Turntable	*	1
1-21	84-190-111-01		Tonearm ass'y S	*	1
1-22	84-190-022-01		Elevation plate C	*	1
1-23	84-190-021-01		Elevation plate B	*	1
1-24	84-190-246-01		Spring, Elevation shaft H	*	1
1-25	84-190-245-01		Spring, Adjustment	*	1
1-26	84-190-242-01		Elevation shaft H	*	1
1-27	84-190-244-01		Elevation shaft bearing A	*	1
1-28	87-081-596-01		Rifter screw		1
1-29	84-190-087-01		Cushion, Rest	*	1
1-30	84-190-092-01		Arm rest ass'y S	*	1
1-31	84-190-093-01		Holder A ass'y, Rest S	*	1
1-32	84-190-108-01		Label, Stylus (H,UK model only)	*	1
1-33	84-190-202-01		Shaft A, Cam wheel	*	1
1-34	84-190-284-01		Shaft Q, Syncrate	*	1
1-35	84-184-411-01		Lug terminal, Tonearm		1
1-36	84-190-201-01		Gear A, Cam wheel	*	1
1-37	84-190-205-01		Auto lever C	*	1
1-38	84-190-204-01		Auto lever B	*	1
1-39	84-190-203-01		Auto lever A	*	1
1-40	84-190-206-01		Stopper A, Cam wheel	*	1
1-41	84-190-207-01		Spring, Cam wheel stopper A	*	1
1-42	84-190-960-01		Screw, Cartridge stopper (H, UK model only)	*	2
1-43	84-184-956-01		Washer, Cartridge stopper (H, UK model only)		2
1-44	84-190-976-01		Head shell ass'y	*	1
1-45	84-190-972-01		Spacer, Cartridge	*	1
1-46	84-190-973-01		Damper, Shell	*	1
1-47	84-190-975-01		Shield plate, Cartridge (H, UK model only)	*	1
1-48	84-190-964-01		Cover, Stylus (H, UK model only)	*	1
1-49	84-184-955-01		Nut		2
1-50	84-190-978-01		Adaptor, 45	*	1
1-51	87-038-039-01		Wire binder		1
1-52a	84-190-076-01		Name plate, Spec. (H model only)	*	1
1-52b	84-190-073-01		Name plate, Spec. (EE model only)	*	1
1-52c	84-190-078-01		Name plate, Spec. (UK model only)	*	1

Ref. No.	Part No.	Description	Q'ty
1-101	87-343-095-01	UT ₂ + 3-8	11
1-102	87-343-094-01	UT ₂ + 3-6	1
1-103	87-501-093-01	VF + 3-5	1
1-104	87-410-325-01	W4-10-0.8	3
1-105	87-081-587-01	PW4.2-10-0.5	1
1-106	87-441-009-01	STE-3	1

Ref. No.	Part No.	Description	Q'ty
1-107	87-441-011-01	STE-4	1
1-108	87-442-003-01	STP-3	3
1-109	87-364-032-01	SSH2-3	1
1-110	87-081-592-01	N-14	1
1-111	87-081-593-01	N-8	1

EXPLODED VIEW-2

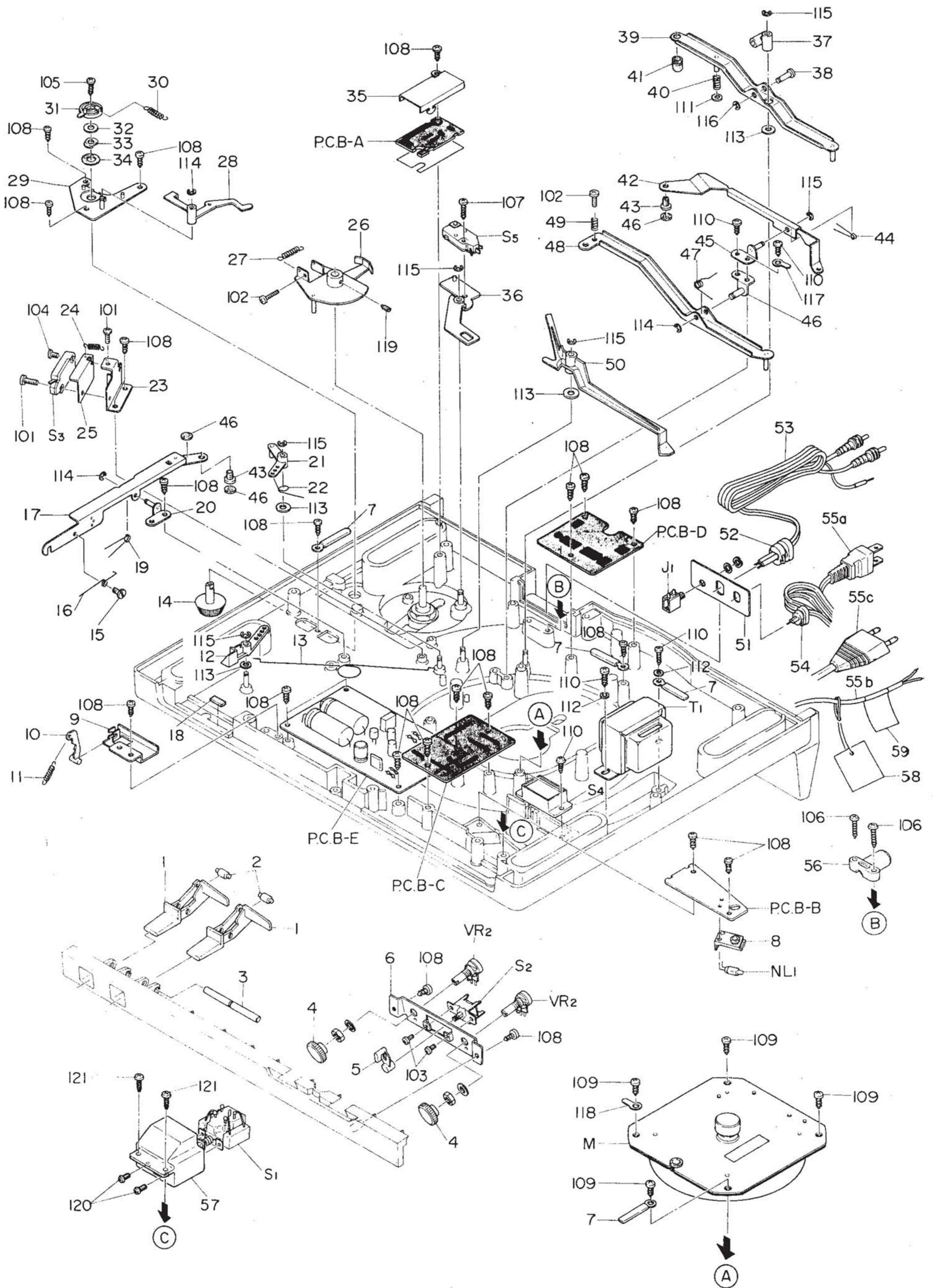

SCHEMATIC DIAGRAM

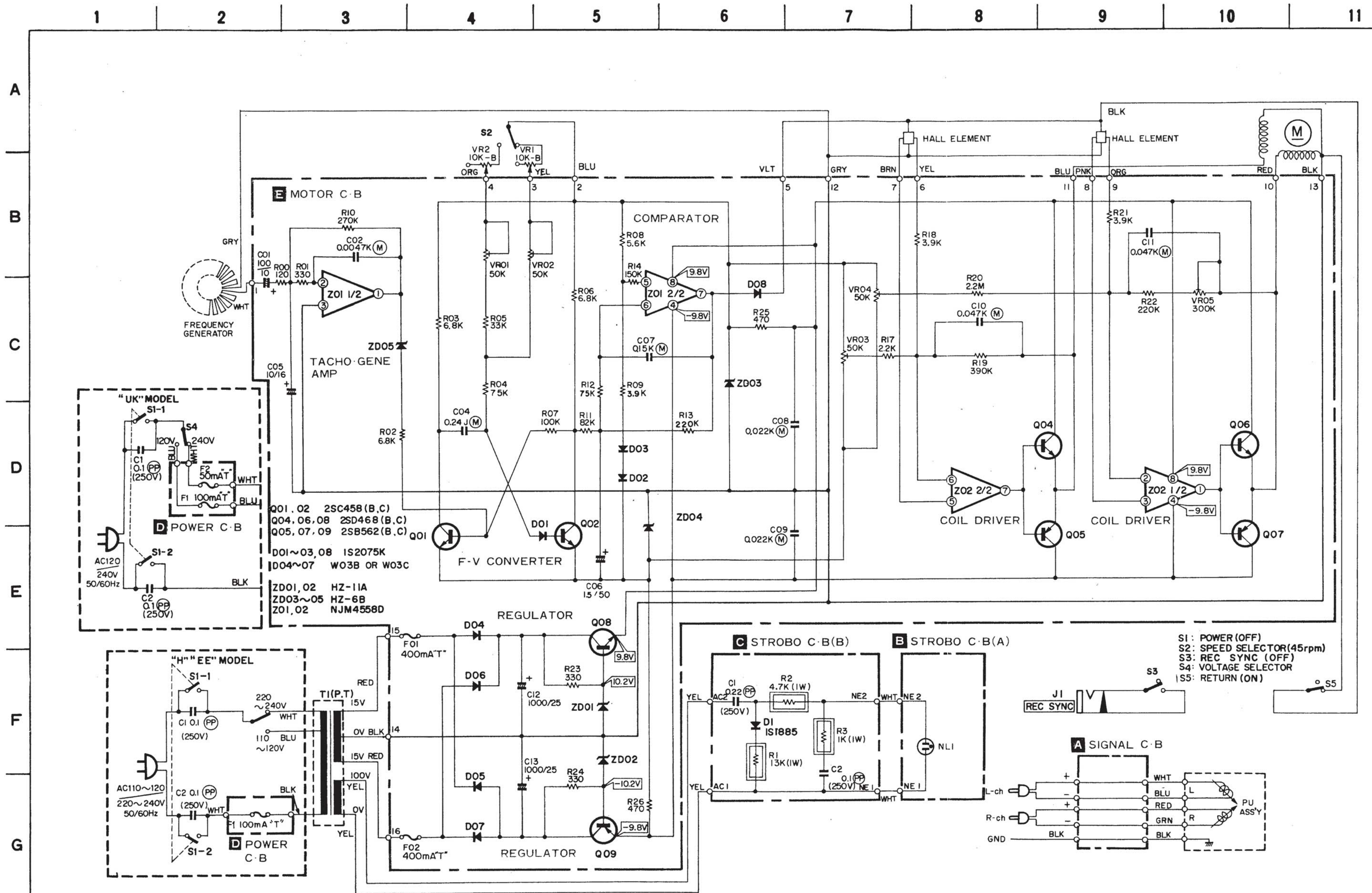

ELECTRICAL MAIN PARTS LIST

Symbol No.	Part No.	Description
<< SIGNAL CIRCUIT BOARD SECTION >>		
PCB-A	84-190-607-01	Signal circuit board
<< STROBO CIRCUIT BOARD (A) SECTION >>		
PCB-B	84-190-608-01	Strobo circuit board (A)
NL1	82-184-602-01	Neon lamp
<< STROBO CIRCUIT BOARD (B) SECTION >>		
PCB-C	84-190-615-01	Strobo circuit board (B)
D1	87-027-083-01	Diode, 1S1885
< Resistors >		
R3	84-190-618-01	1kΩ 1W Nonflammable resistor
R2	84-190-619-01	4.7kΩ 1W Nonflammable resistor
R1	87-025-106-01	13kΩ 1W Nonflammable resistor
< Capacitors >		
C2	84-190-617-01	0.1μF 250V PP (H model only)
C2	84-190-622-01	0.1μF 250V PP (EE, UK model only)
C1	84-190-616-01	0.22μF 250V PP (H model only)
C1	84-190-621-01	0.22μF 250V Line capacitor (EE, UK model only)
<< POWER CIRCUIT BOARD SECTION >>		
PCB-D	84-190-606-21	Power circuit board (H, EE model only)
PCB-D	84-190-642-01	Power circuit board (UK model only)
F1	87-035-067-01	Fuse, 100mA "T" (H, EE model only)
F1	87-035-131-01	Fuse, 100mA "T" (UK model only)
F.2	87-098-006-01	Fuse label, 100mA "T"
F.2	87-035-066-01	Fuse label, 50mA "T" (UK model only)
F.2	87-098-003-01	Fuse label, 50mA "T" (UK model only)
<< MISCELLANEOUS >>		
T1	84-190-602-01	Power transformer (H, EE model only)
T1	84-190-640-01	Power transformer (UK model only)
M, PCB-E	84-190-639-01	Motor ass'y
J1	82-422-612-11	Jack 2.5φ (REC SYNC)
VR1,2	84-184-610-01	Volume, 10kΩ-B (SPEED ADJUST)
S1	87-031-408-01	Push switch (POWER)
S2	84-190-611-01	Lever switch (SPEED SELECTOR)
S3	84-190-612-01	Micro switch (REC SYNC)
S4	87-031-364-01	Slide switch (VOLTAGE SELECTOR)
S5	84-190-627-01	Micro switch (RETURN)
< Capacitors >		
C1,2	84-190-617-01	0.1μF 250V PP (H model only)
C1,2	84-190-622-01	0.1μF 250V Line capacitor (EE, UK model only)

REMARKS:
Test record TRA-303 ... for Frequency response, Cross-talk, S/N, and Wow & flutter.

- NOTE:**
- The voltage is the reference value measured with a tester (50 kΩ/V·DC) when there are no signals.
 - Resistors with no designation have a rated power of 1/4W and a tolerance of ±5%.
 - Capacitors with no designation have a dielectric strength of less than 50WV.
 - The only capacitor tolerances indicated are ±5% (J) and ±10% (K).
 - Explanation of symbols
 Mylar capacitor
 Polypropylene film capacitor
 Non flammable resistor
- * This schematic diagram is subject to change without notice in the interests of improved performance.

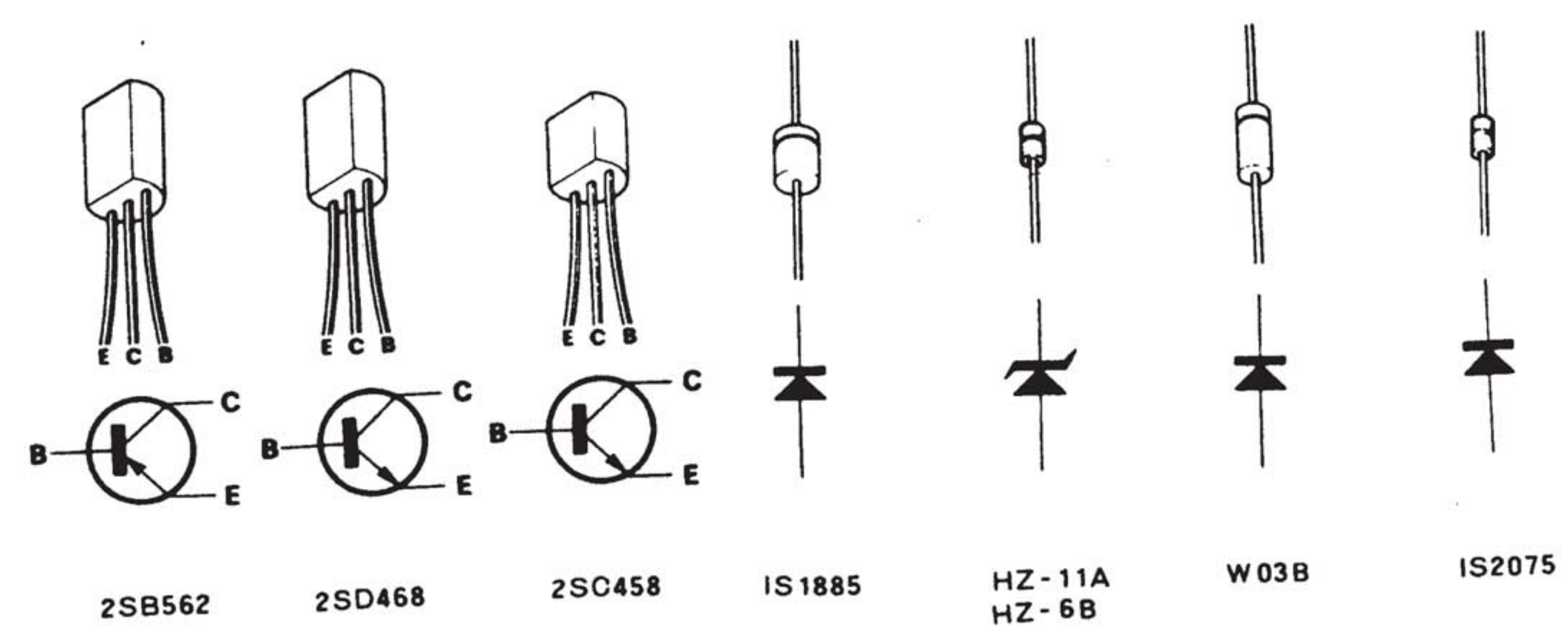

A
B
C
D
E
F
G
H
I
J

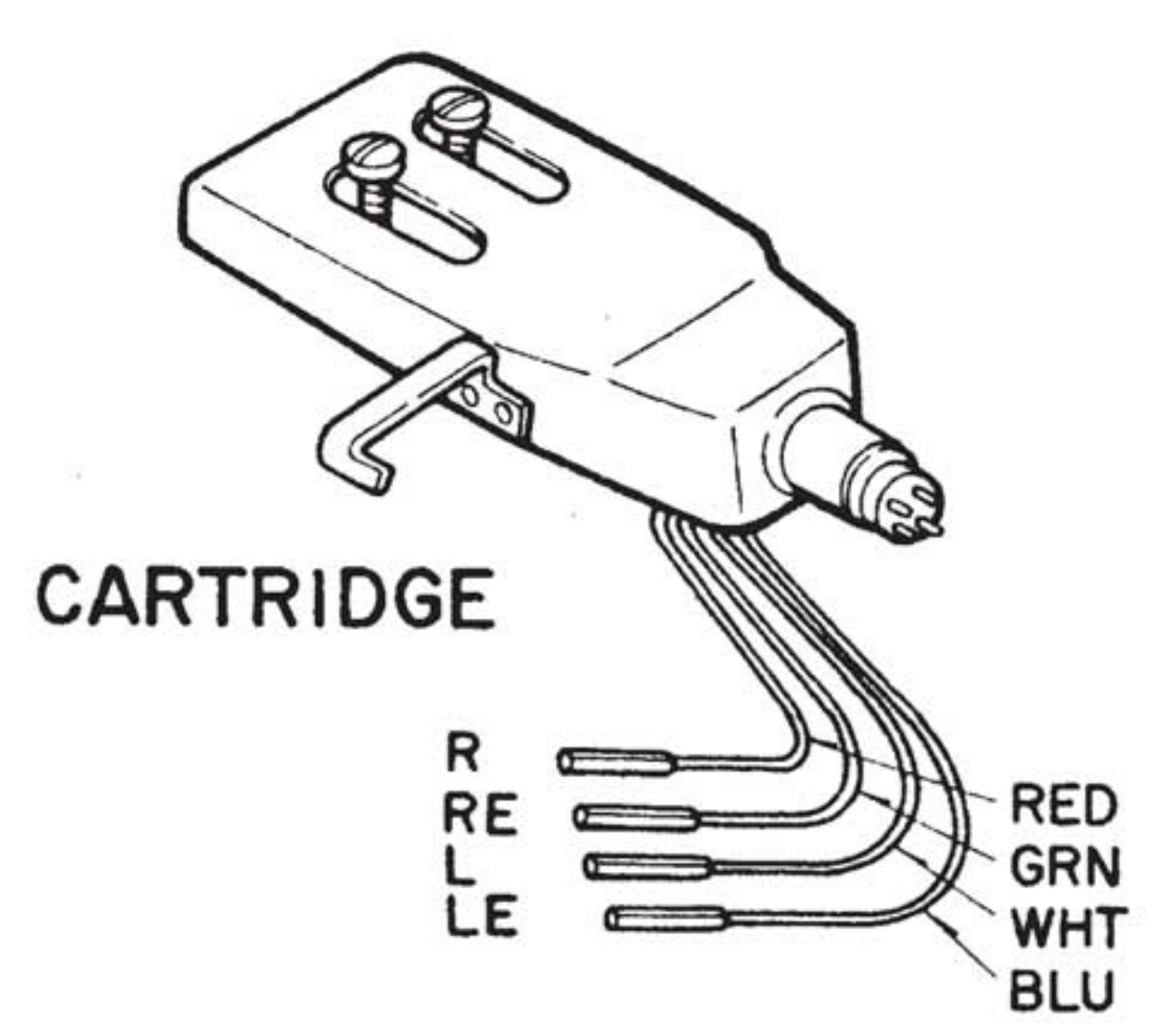
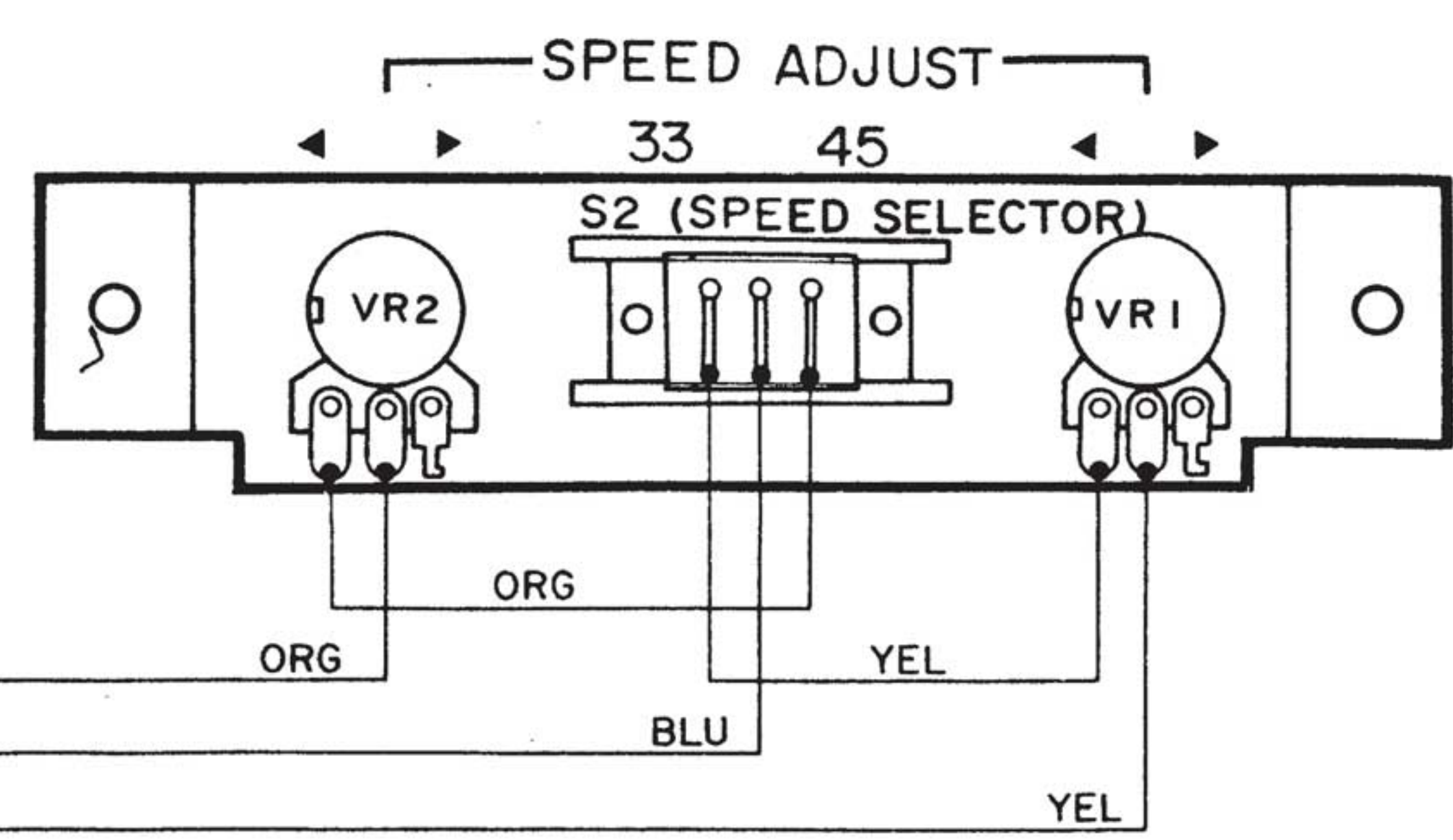
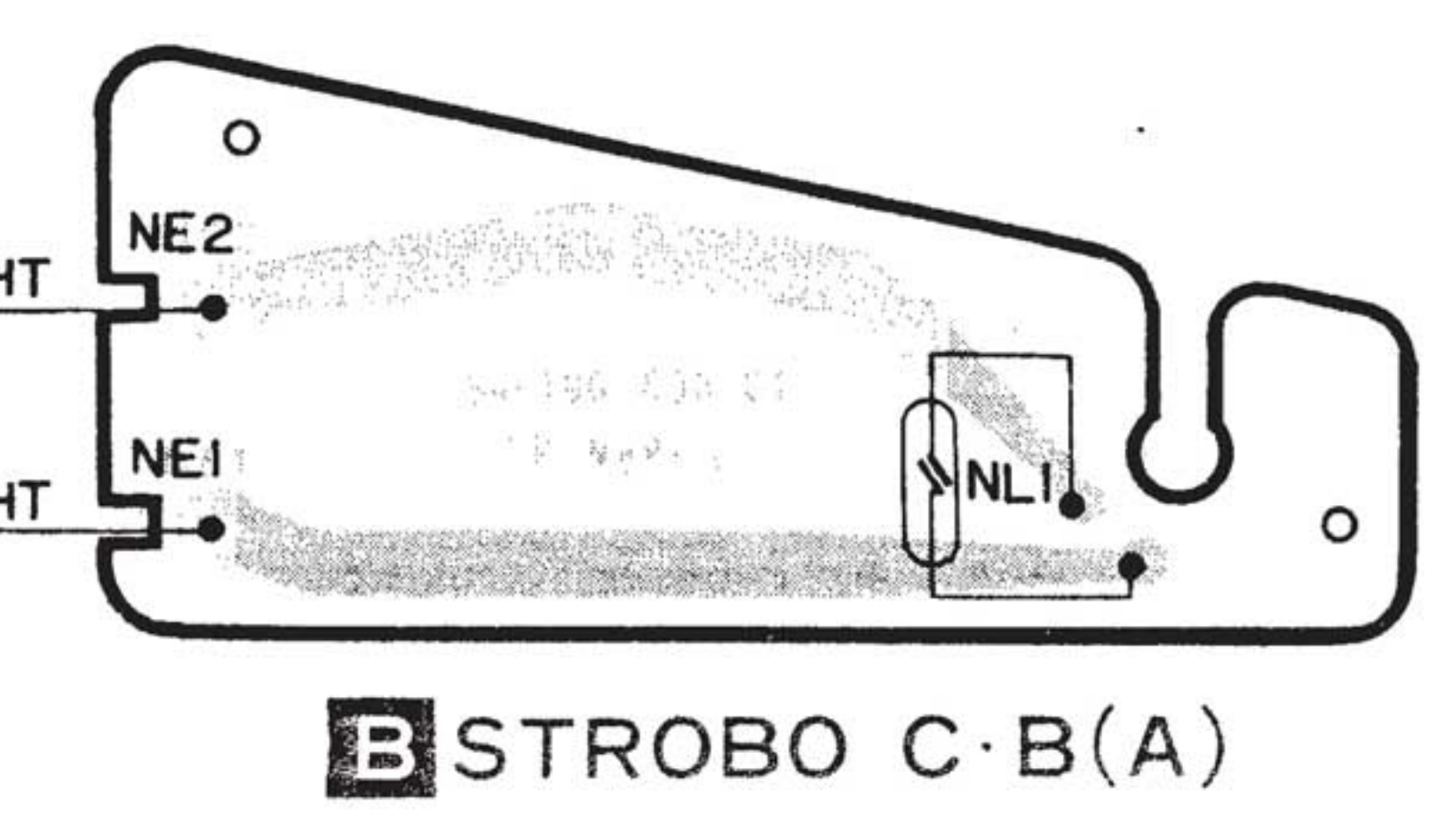
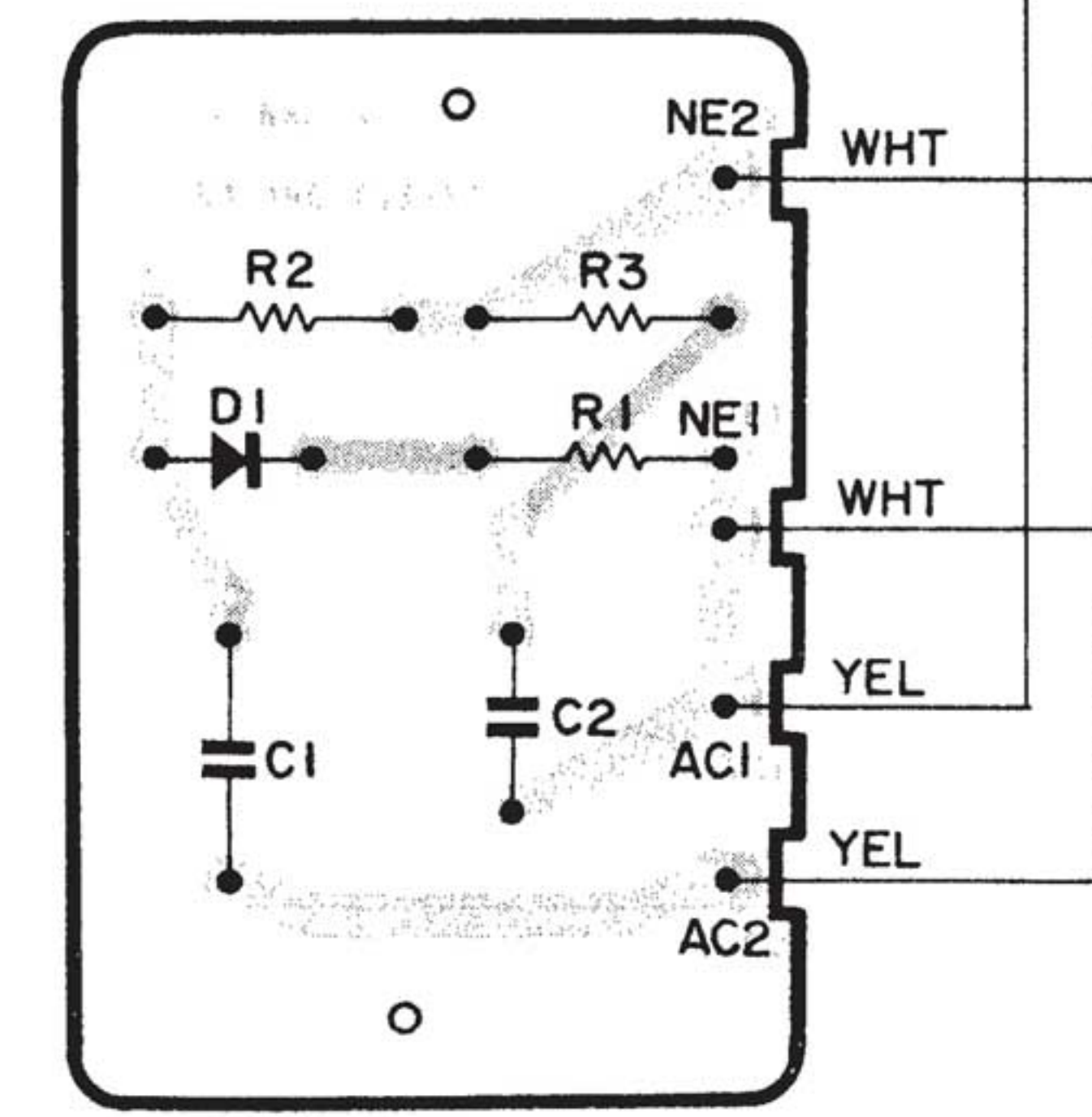
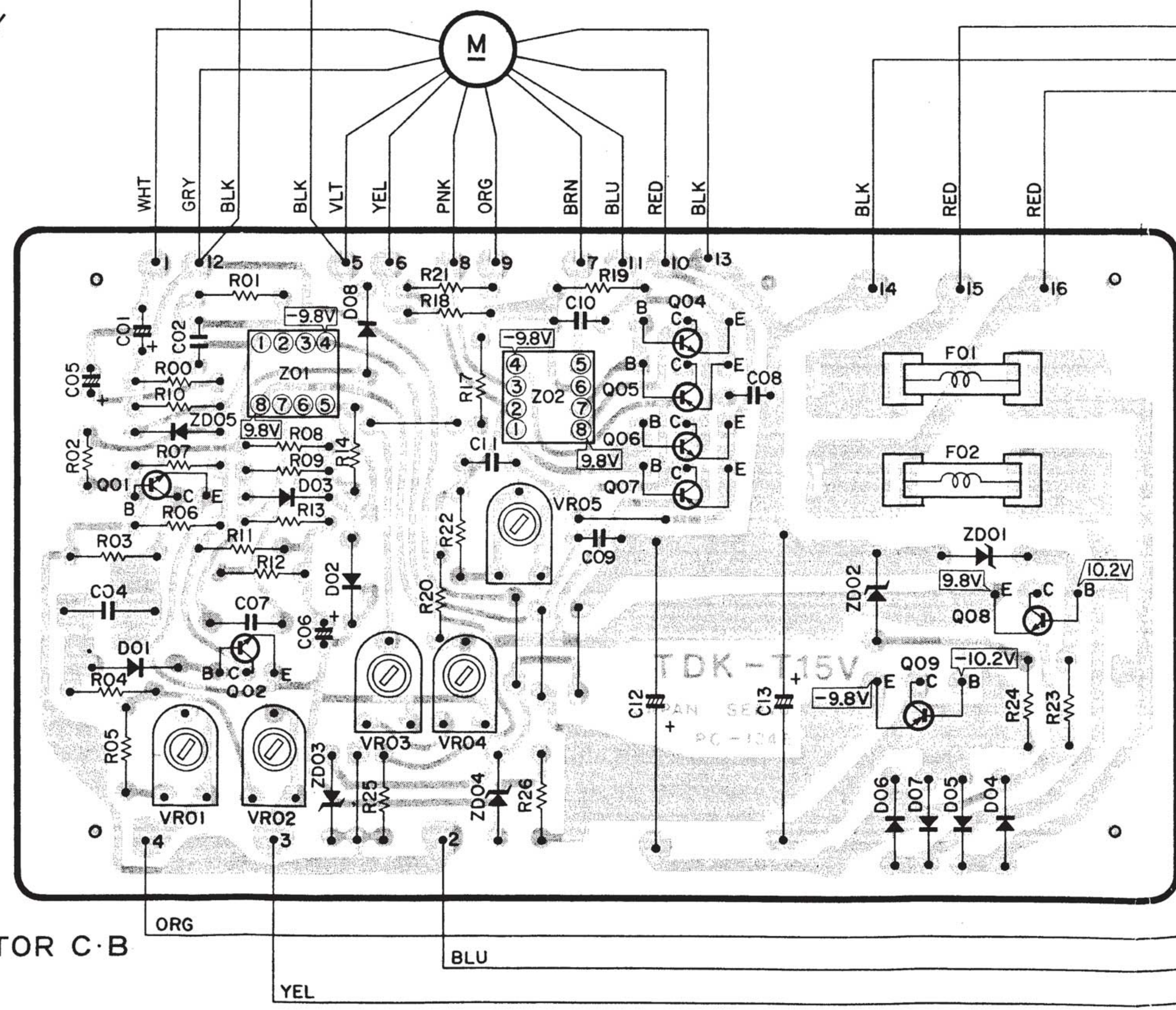
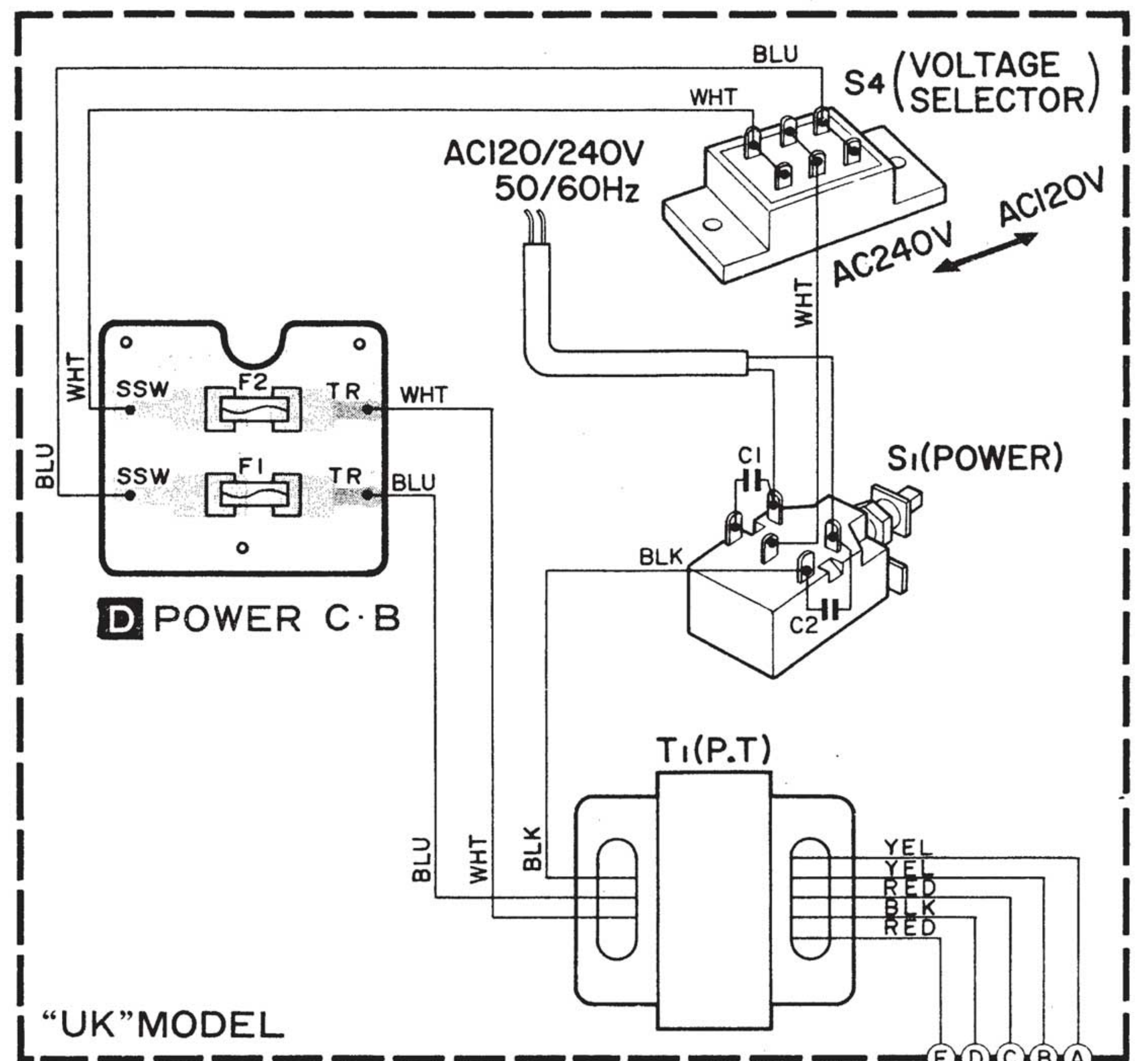
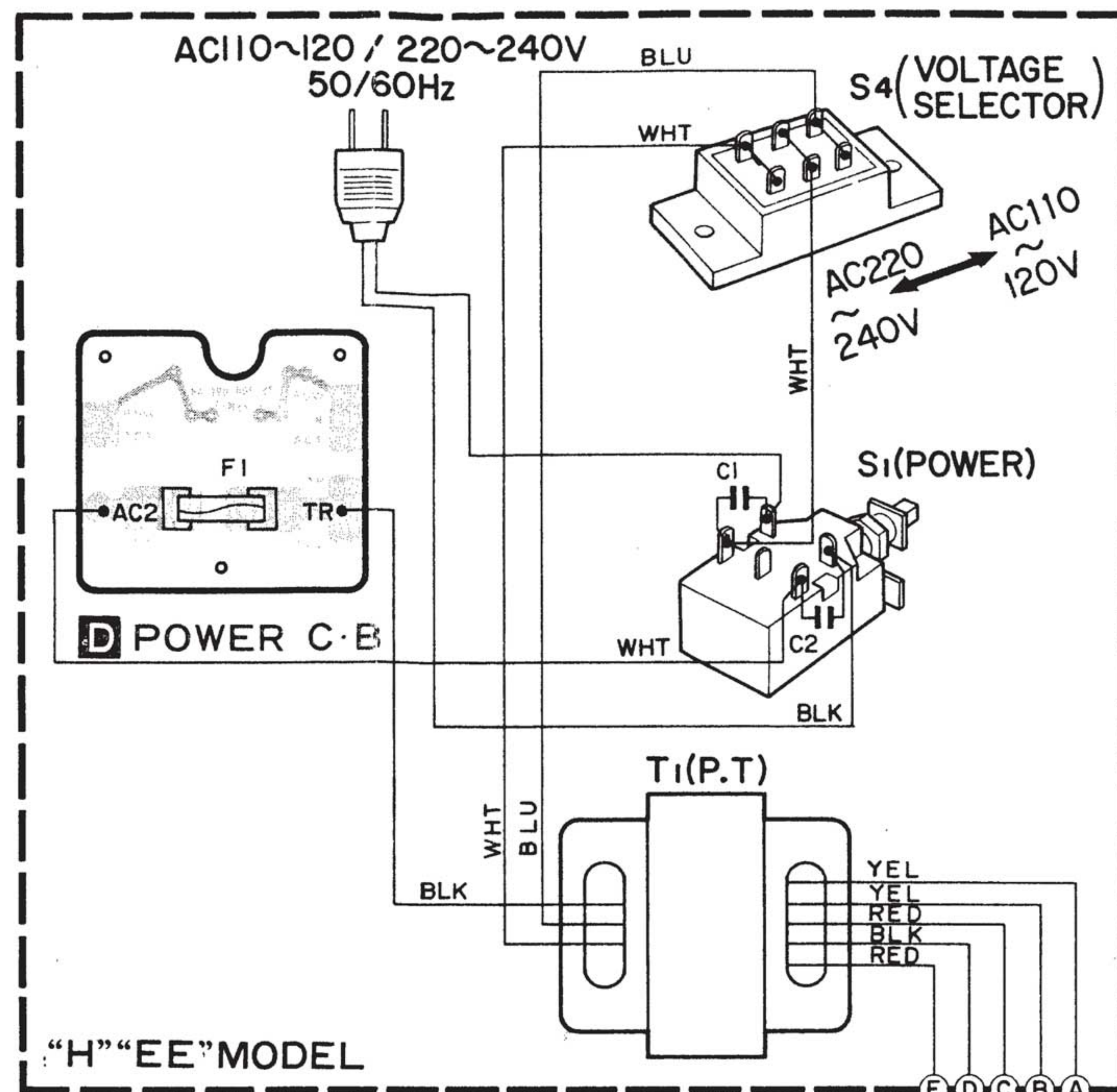
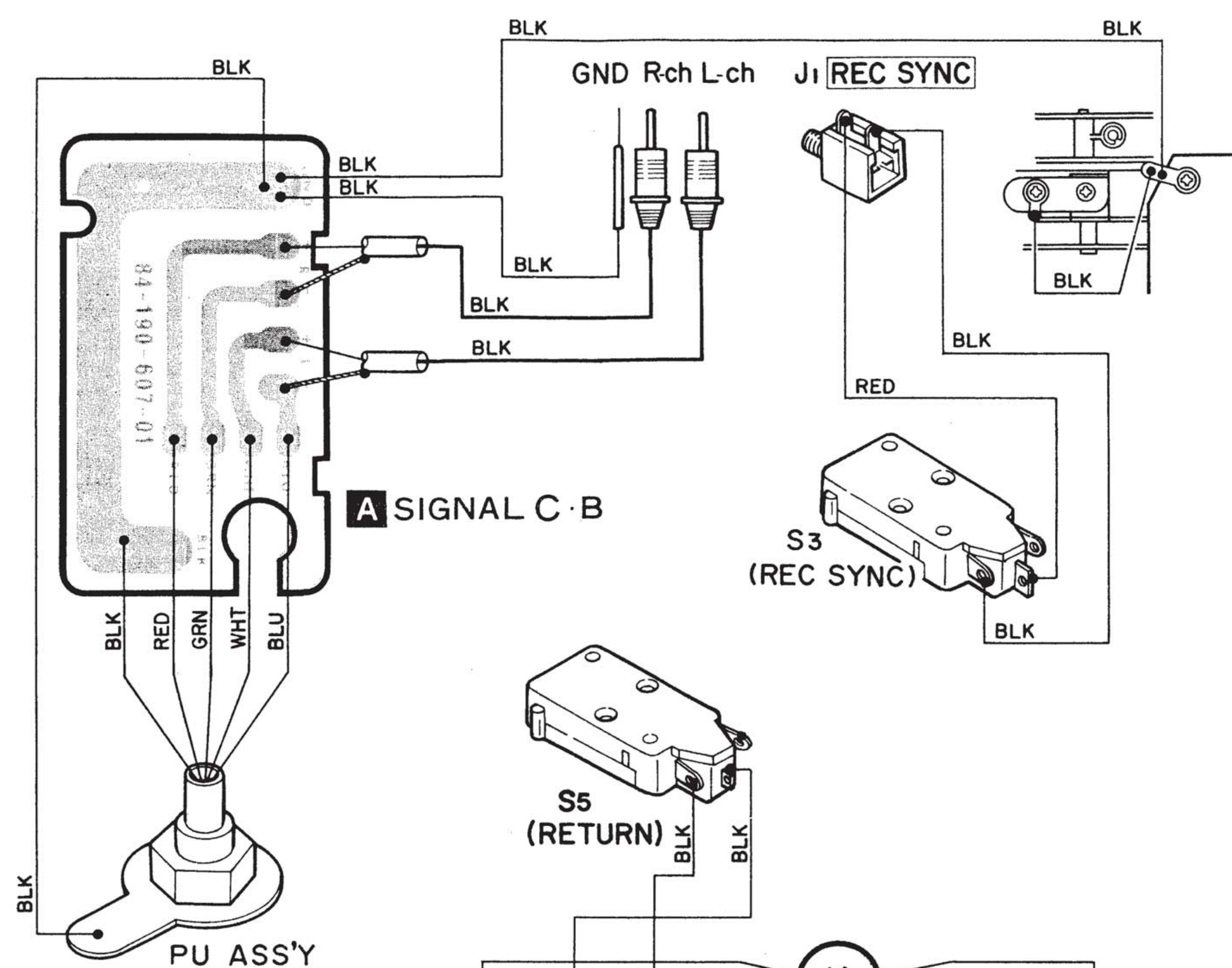

NOTES The voltage is the reference value measured with a tester (50kΩ/VDC) when there are no signals.







Ref. No.	Part No.	Part No. Changed to	Description	Common Model	Q'ty
2-1	84-190-109-01		Push-key	*	2
2-2	84-190-290-01		Sub-bar A	*	2
2-3	84-190-253-01		Shaft K, Push-key	*	1
2-4	84-190-011-01		Volume knob	*	2
2-5	84-190-012-01		Switch knob	*	1
2-6	84-190-248-01		Holder F, Volume	*	1
2-7	87-038-039-01		Wire binder		4
2-8	84-190-276-01		Rubber bushing, Strobo	*	1
2-9	84-190-268-01		Holder K, Up-Down	*	1
2-10	84-190-267-01		Lever M, Up-Down	*	1
2-11	84-190-273-01		Spring, Up-Down lever M	*	1
2-12	84-190-220-01		Cut lever F	*	1
2-13	84-190-222-01		Wire, Relay	*	1
2-14	84-190-055-01		Knob, Inside force canceller	*	1
2-15	87-081-483-01		Motor screw		1
2-16	84-190-280-01		Spring, Up-Down lever E	*	1
2-17	84-190-214-01		Lever E, Up-Down	*	1
2-18	84-190-295-01		Spacer, Push-key	*	1
2-19	84-190-275-01		Spring, Up-Down	*	1
2-20	84-190-211-01		Holder C ass'y	*	2
2-21	84-190-221-01		Lever G, Relay	*	1
2-22	84-190-223-01		Spring, Relay lever G	*	1
2-23	84-190-233-01		Syncrat plate D	*	1
2-24	84-190-234-01		Spring, Syncrate plate D	*	1
2-25	84-190-232-01		Syncrate plate D	*	1
2-26	84-190-236-01		Lever F ass'y	*	1
2-27	84-190-241-01		Spring, Lever F ass'y	*	1
2-28	84-190-263-01		Lever K, Inside force canceller	*	1
2-29	84-190-257-01		Holder J ass'y, Inside force canceller	*	1
2-30	84-190-262-01		Spring, Slip pulley	*	1
2-31	84-190-260-01		Slip pulley	*	1
2-32	82-285-236-01		Washer, Carrying handle		1
2-33	82-416-341-01		Wave washer		1
2-34	84-190-261-01		Felt, Slip	*	1
2-35	84-190-605-01		Shield plate	*	1
2-36	84-190-231-01		Lever I, Micro switch	*	1
2-37	84-190-228-01		Holder E, Return lever	*	1
2-38	84-190-299-01		Shaft G	*	1
2-39	84-190-224-01		Lever H, Return A ass'y	*	1
2-40	84-190-256-01		Spring, Lever H ass'y	*	1
2-41	84-190-230-01		Rubber, Friction	*	1
2-42	84-190-269-01		Lever L, Up-Down	*	1
2-43	82-331-107-21		Screw, Thrust adjustment		2
2-44	84-190-274-01		Spring, Up-Down lever L	*	1
2-45	84-190-271-01		Holder L ass'y	*	1
2-46	84-184-373-01		Cushion		3
2-47	84-190-255-01		Spring, Lever D seesaw ass'y	*	1
2-48	84-190-208-01		Lever D seesaw ass'y	*	1
2-49	84-190-282-01		Spring, Lever D seesaw adjustment	*	1
2-50	84-190-235-01		Lever J	*	1
2-51	84-190-018-01		Name plate, Jack	*	1
2-52	87-085-160-01		Cord bushing, Pin cord		1
2-53	84-184-618-01		Pin cord		1
2-54	87-085-101-01		Cord bushing, AC cord (H model only)		1
2-55a	87-034-826-01		AC cord (H model only)		1
2-55b	87-034-835-01		AC cord (EE model only)		1
2-55c	87-034-848-01		AC cord (UK model only)		1
2-56	87-085-094-01		Holder, AC cord (EE, UK model only)		1
2-57	84-190-288-01		Cover, Power switch	*	1
2-58	87-056-008-01		Label, AC cord (UK model only)		1
2-59	87-056-014-01		Tag, Main voltage (UK model only)		1

Ref. No.	Part No.	Description	Q'ty	Ref. No.	Part No.	Description	Q'ty
2-101	87-251-098-01	U + 3-14	2	2-111	87-410-325-01	W4-10-0.8	1
2-102	87-251-103-01	U + 3-25	2	2-112	87-421-306-01	SW-3	2
2-103	87-251-071-01	U + 2.6-4	2	2-113	87-081-587-01	PW4.2-10-0.5	4
2-104	87-251-097-01	U + 3-12	1	2-114	87-441-006-01	STE-2.3	3
2-105	87-341-193-01	UT ₁ + 3-5	1	2-115	87-441-009-01	STE-3	6
2-106	87-341-098-01	UT ₁ + 3-14	2	2-116	87-441-010-01	STE-3.2	1
2-107	87-343-098-01	UT ₂ 3-14	1	2-117	87-450-412-01	LB-2	2
2-108	87-343-094-01	UT ₂ + 3-6	24	2-118	87-450-416-01	LB-6	1
2-109	87-343-171-01	UT ₂ + 4-10	4	2-119	87-364-073-01	SSH2.6-6	1
2-110	87-343-095-01	UT ₂ + 3-8	6	2-120	87-263-093-01	V + 3-5	2
				2-121	87-343-096-01	UT ₂ + 3-10	2

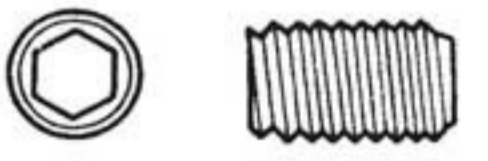
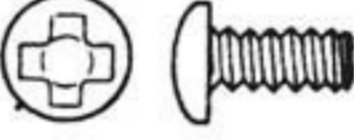
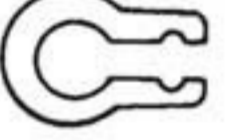
ACCESSORIES/PACKAGE

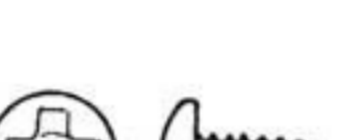
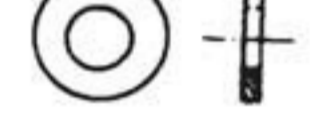
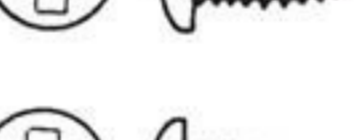
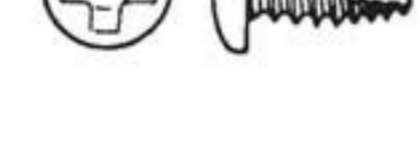
Ref. No.	Part No.	Part No. Changed to	Description	Common Model	Q'ty
1	84-190-864-01		Printed indiv., Packing	*	1
2	84-190-852-01		Cushion L, Printed indiv.	*	1
3	84-190-853-01		Cushion R, Printed indiv.	*	1
4	84-190-854-01		Cushion A, Auxiliary	*	1
5	84-184-860-01		Sheet, Foamed mat,		1
6	87-056-500-01		curl stopper		2
7	87-056-550-01		Poly-vinyl sack (for case)		1
8	87-051-171-01		Poly-vinyl sack (for instructions)		1
9a	84-190-904-01		Instructions booklet (H model only)	*	1
9b	84-190-905-01		Instructions booklet (EE model only)	*	1
9c	84-190-906-01		Instructions booklet (UK model only)	*	1
10	87-051-132-01		Poly-vinyl sack (for weight, shell)		H,UK:3 EE:4
11	87-051-136-01		Poly-vinyl sack		1
12	87-051-140-01		Poly-vinyl sack (for turntable)		1
13	87-056-009-01		Distributors list		1
14	84-184-961-01		Screw, Cartridge stopper (EE model only)		2
15	84-184-974-01		Screw S, Cartridge stopper (EE model only)		2
16	87-058-023-01		Cord binder		2

HARDWARE NO MENCLATURE

V:	Pan head screw		SSH:	Hexagon Socket SET screw	
U:	Binding head screw		STP:	Powerful stop ring	
P:	Oval countersunk head screw		STE:	E ring	
UT1:	Binding head tapping screw		W:	Washer	
UT2:	Binding head tapping screw		PW:	Poly-slider washer	
VF:	Flange and Pan head screw		SW:	Spring washer	
			N:	Nut	
			LB:	Lug terminal plate	

Example:

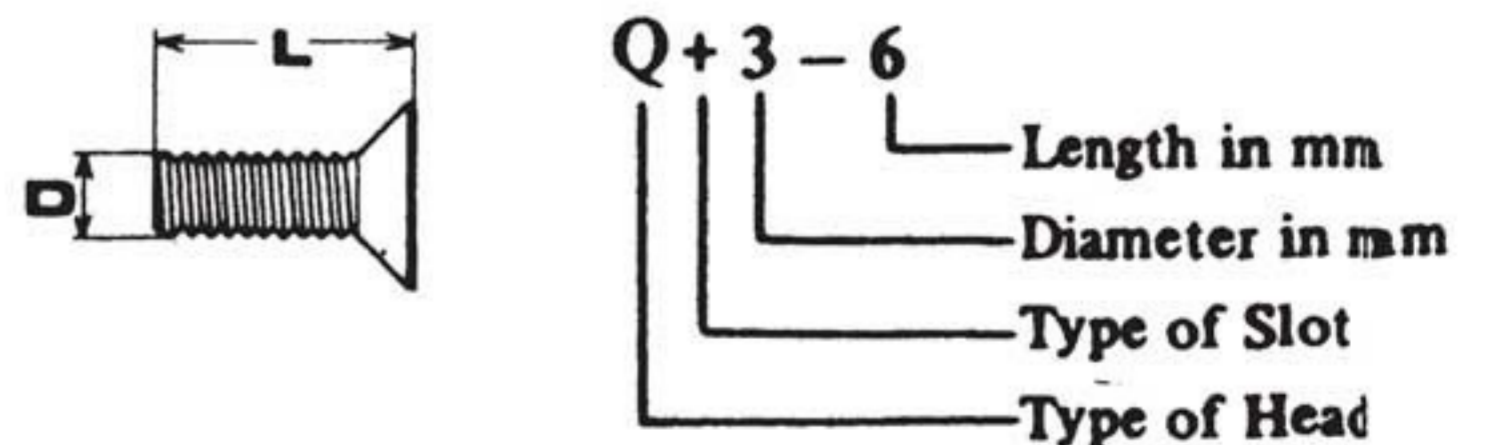
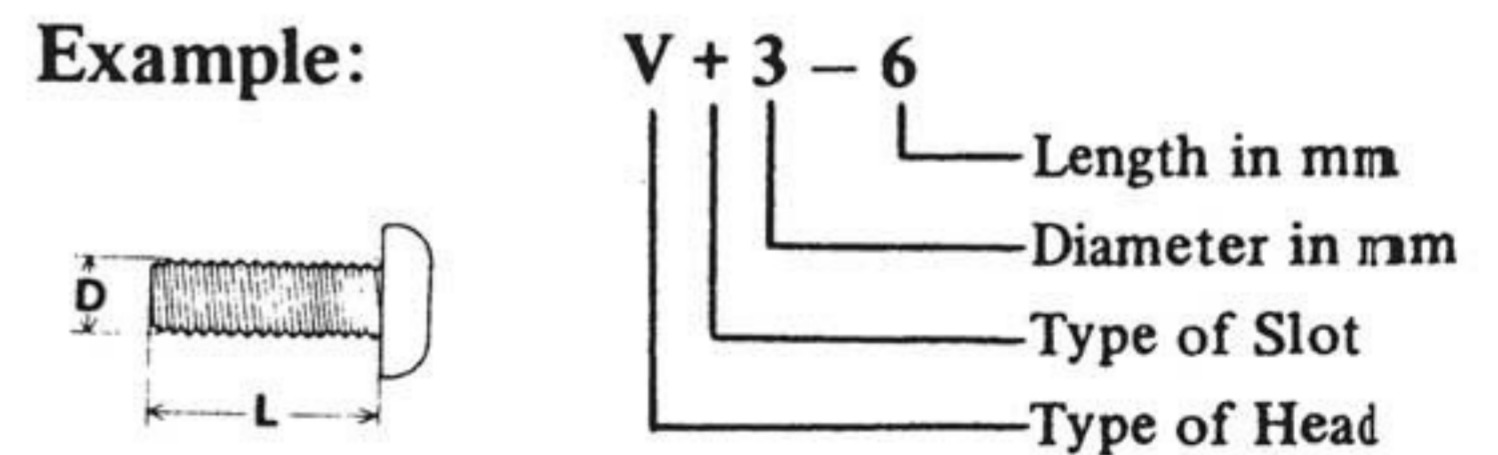

AIWACO.,LTD.