

# DIRECT DRIVE STEREO TURNTABLE SYSTEM

## MODEL AP-2500H,EE,UK

# AIWA®

## [SERVICE MANUAL]



Set using ISO screws

DATE OF ISSUE 30/11/1977

### SPECIFICATIONS

Type: Direct Drive Stereo Turntable System  
Circuitry:  
Power Supply: AP-2500H,EE:  
AC 120 V/220 V (switchable)  
50/60 Hz  
AP-2500UK:  
AC 120 V/240 V (switchable)  
50/60 Hz

Power Consumption: 13 W

Dimensions: 480 W x 152 H x 404 D mm.

Weight: 10.5 kg

#### TURNTABLE

Type: Direct drive type  
Motor: FG Servo 3-phase, 8-pole, 24-slot DC  
Direct Drive motor  
RPM: 33 1/3 rpm, 45 rpm  
RPM range:  $\pm 4\%$  (45 rpm)  
Platter: Die-cast aluminum, 314 mm diameter  
S/N ratio: More than 60 dB (IEC B Curve)  
Wow/flutter: Less than 0.03% (WRMS)

#### TONE ARM

Type: Static balanced  
Effective length: 237 mm  
Overhang: 15 mm  
Tracking error:  $+2.1^\circ, -1.6^\circ$   
Off-set angle:  $22^\circ$   
Stylus pressure range: 0 – 3 grams  
Acceptable cartridge weight: 3 – 14 grams  
11 – 22 grams (with auxiliary weight)  
Maximum acceptable cartridge-headshell weight: 32.5 grams (with auxiliary weight)

#### ACCESSORIES

Head shell  
45 rpm adaptor

The specifications and external appearance of this set are subject to change without prior notice.

ASSEMBLY INSTRUCTIONS

Remove Back Cover  
Remove 4 rubber feet and 9 screws.

Remove Motor  
Remove 3 screws.

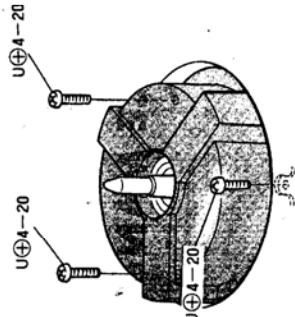

To Remove Micro Switch Fitting  
Remove mounting screw.

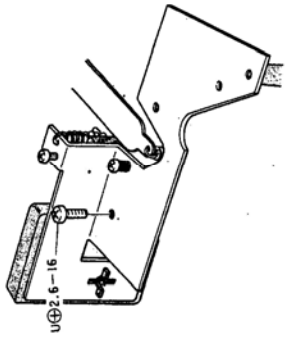

To Remove Sessaw Assy and Holder L  
1) Remove 2 screws.  
2) Remove mounting setscrew.

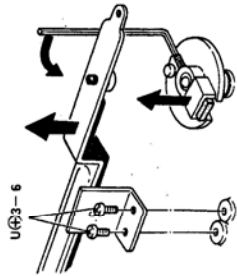

To Remove Detection Plate Assy  
1) Remove mounting screw.  
2) Remove mounting setscrew.

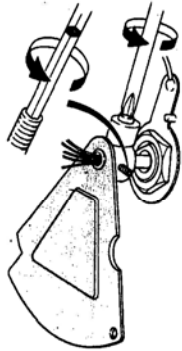

To Remove Relay Circuit Board  
1) Remove mounting screw of the shield plate A, and this plate can then be removed by pulling it in the direction of the arrow.

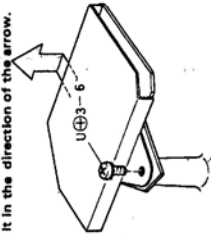

2) Remove the T spring and detach the lead wire of the tonearm with a soldering iron.

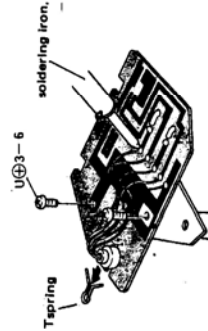

Remove Tonearm  
Remove 1 hexagon nut.

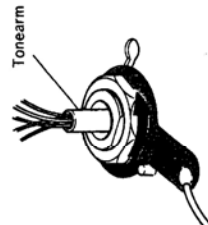

To Remove Lamp Circuit Board  
Remove 2 screws.

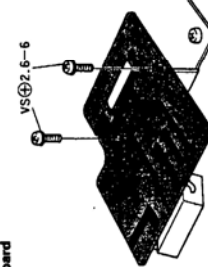

To Remove Touch Circuit Board  
1) Disconnect 3 connectors.  
2) Remove 3 screws.

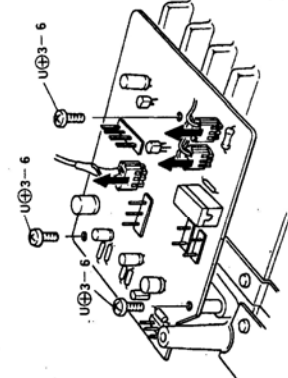

To Remove Main Circuit Board  
1) Disconnect 1 connector.  
2) Remove 4 screws.

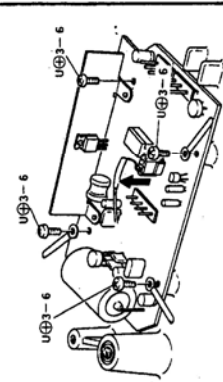

To Remove Power Circuit Board  
Remove 3 screws.

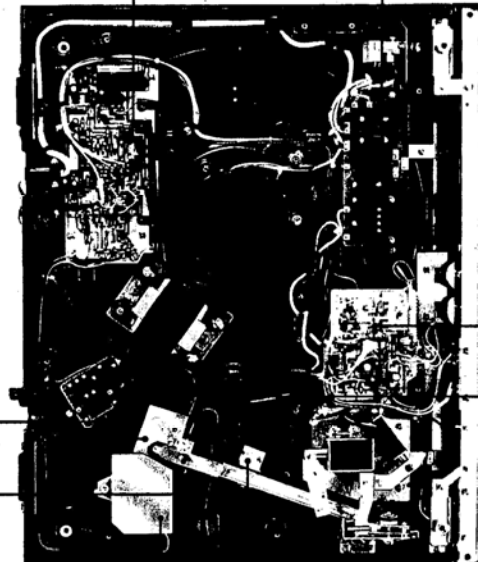
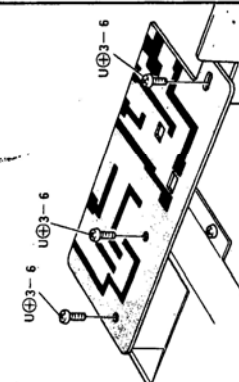

**ADJUSTMENTS**

**1. Sync rate operation adjustment**

Place an LP (30 cm diameter) record on the platter and adjust as follows so that the sync rate operation starts when the stylus makes contact with the surface of the record.  
(Refer to Fig. 1)

- 1) Rotate the adjust screw to the right if the sync rate operation is too slow.
- 2) Rotate the adjust screw to the left if the sync rate operation is too fast.

**Note:** When adjusting the sync rate, connect to a product provided with a (PLAYER SYNC) jack and then proceed.

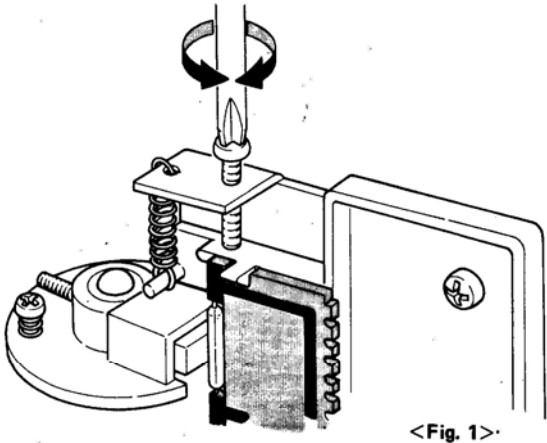

<Fig. 1>

**2. Stylus height position adjustment**

Adjust the height of the stylus at UP and DOWN settings as follows. (Refer to Fig. 2)

**1) Up height adjustment of stylus**

- \* When the stylus is too high — Rotate the DOWN adjust screw to the right and adjust so that the stylus comes into contact with the spacer.  
(Refer to Fig. 2 and Fig. 3)
- \* When the stylus is too low — Rotate the DOWN adjust screw to the left and adjust so that the stylus is at the same height as the spacer.  
(Refer to Fig. 2 and Fig. 3)

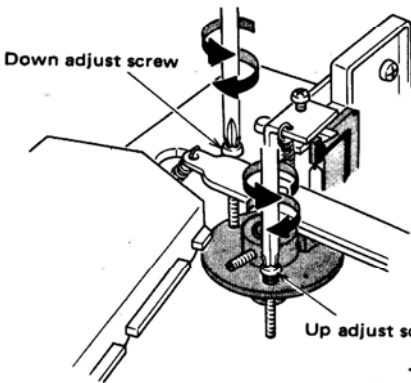

<Fig. 2>

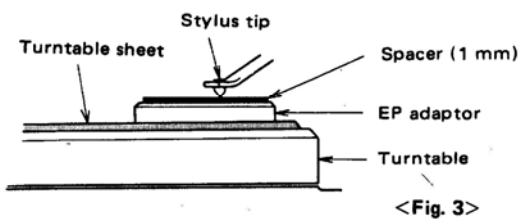

<Fig. 3>

**2) DOWN height adjustment of stylus**

- \* When the stylus is too high — Rotate the UP adjust screw to the right and adjust the stylus to the position in the figure.  
(Refer to Fig. 2 and Fig. 4)
- \* When the stylus is too low — Rotate the UP adjust screw to the left and adjust the stylus to the position in the figure.  
(Refer to Fig. 2 and Fig. 4)

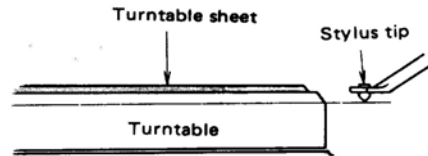

<Fig. 4>

**3. Free stop position adjustment**

Adjust the free stop as follows if it is defective.

- 1) Check that the clearance between the slip lever collar and the UP lever is 0.5 mm. If there is no clearance, bend the UP lever and adjust. (Refer to Fig. 5)

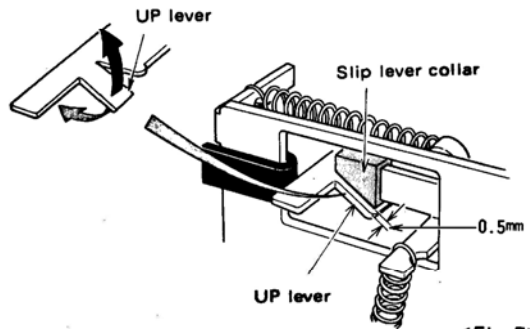

<Fig. 5>

- 2) The pulley sub ass'y and the contact section of the main operating unit sometimes slip and so wipe these parts clean. (Refer to Fig. 6)

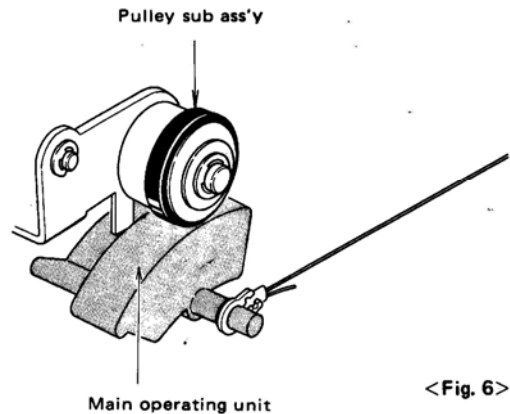

<Fig. 6>

**4. Free start position adjustment**

Set the operating lever to the free start mode and adjust as follows if it cannot be set to the free stop mode.

- 1) Rotate the seesaw thrust screw horizontally and then adjust so that it will be actuated at the 15 mm rating. (Refer to Fig. 7)

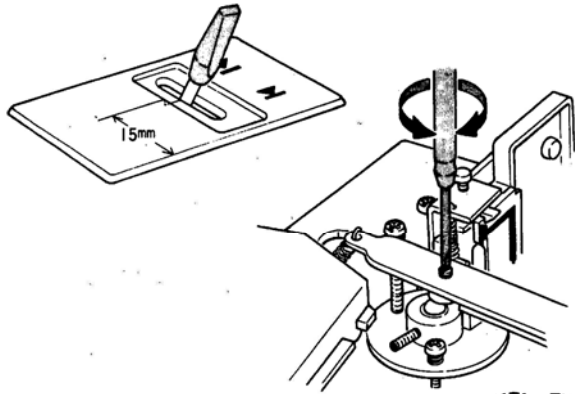

<Fig. 7>

**5. Plunger UP adjustment**

If the plunger UP operation is defective, adjust the UP lever by bending it up or down so that the clearance between the slip lever collar and the UP lever is kept to 0.5 mm. (Refer to Fig. 8)

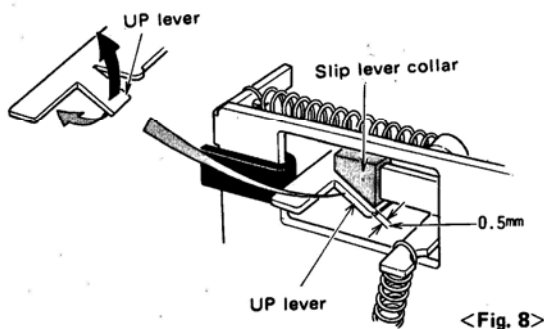

<Fig. 8>

**6. Plunger position adjustment**

Attach the lock plate thread to the relay lever A, push down on the plunger shaft, and with the parts in the positions illustrated in the figure below, secure the solenoid holder K screw when the lock plate thread is stretched taut. (Refer to Fig. 9)

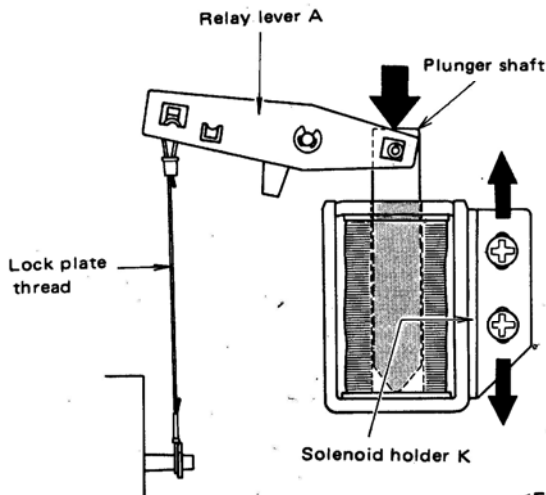

<Fig. 9>

**7. Adjustment with motor replacement**

Check that the clearance between the turntable board and the platter is 0.5 ~ 0.8 mm. (Refer to Fig. 10)

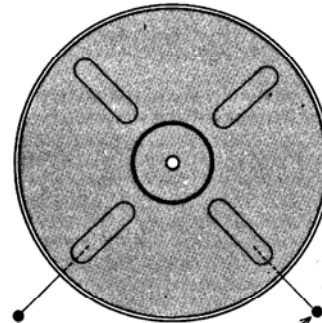

Measure the clearance at the two locations marked with a round dot (\*).

<Fig. 10>

If it is not possible to obtain the above specification, adjust the spacer A (0.3 mm) and spacer B (0.5 mm). (Refer to Fig. 11)

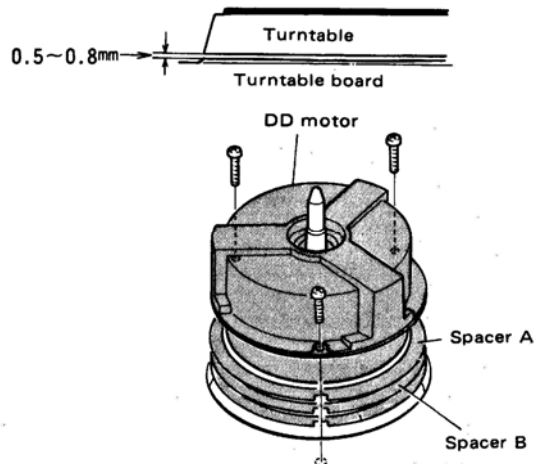

<Fig. 11>

**PRECAUTIONS WITH PARTS REPLACEMENT**

**1. Replacement of plunger**

1) Apply silicon oil #10,000 uniformly all around the plunger shaft.

**Note:** The sound emitted by the operation of the plunger will increase in volume if there is not enough silicon oil. Conversely, the shaft will cease to maintain its rated position if too much silicon oil is applied.

**2. Lock board thread replacement**

1) Arrange the lock board thread so that it meets the specifications illustrated in the figure below.

**Note:** After caulking the grommet, lock using the lock screw. (Refer to Fig. 12)

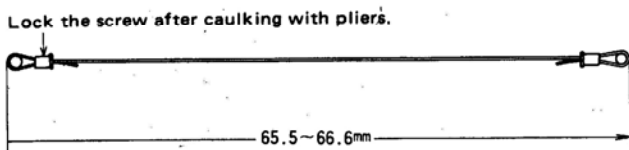

<Fig. 12>

**3. Lifter shaft replacement**

1) When attaching the magnet holder L to the lifter shaft, secure where the lifter shaft projects 2.5 mm from the magnet holder. (Refer to Fig. 13)

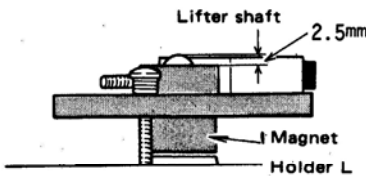

<Fig. 13>

2) Along with the above adjustment, perform the following adjustment, too. Place the elevation plate in the position illustrated in the figure below and then secure the magnet holder L. (Refer to Fig. 14)

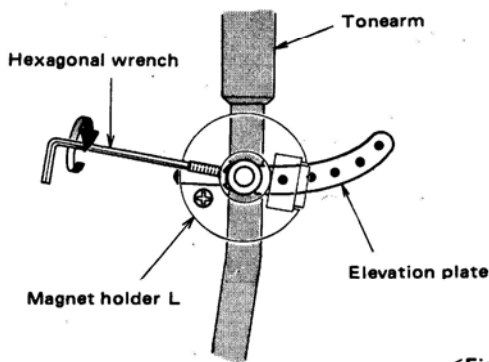

<Fig. 14>

3) Along with the lifter replacement, use the #10,000 as the silicon oil which is applied.

**Note:** When attaching the elevation plate, take care not to allow it to move.

**4. Tonearm replacement**

1) After the tonearm has been mounted, attach the arm's lead wires, bearing in mind the following two points.

- Attach the lead wires so that they do not come into contact with the inner side of the tonearm.
- Do not stretch the lead wires too much or leave them too loose.

2) The screw of the lamp holder should be secured in the center. (Refer to Fig. 15)

3) Attach the detection board to the standard position illustrated in the figure. (Refer to Fig. 15)

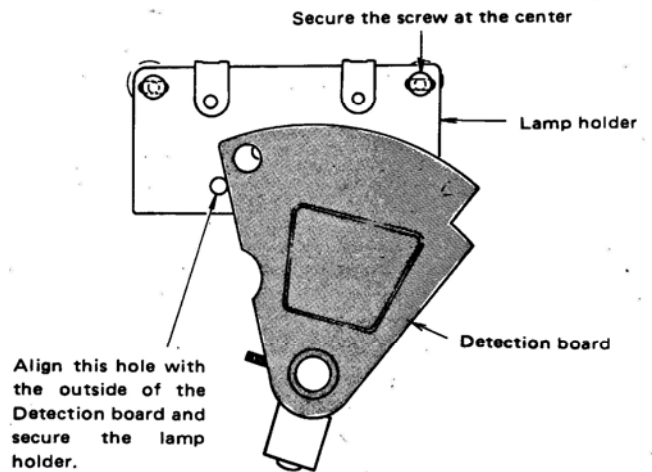

<Fig. 15>

**5. Reed switch replacement**

1) When replacing the reed switch, secure the new switch with a soldering iron in the position marked in the figure. (Refer to Fig. 16)

When replacing the reed switch, align the new switch with this line and then attach.

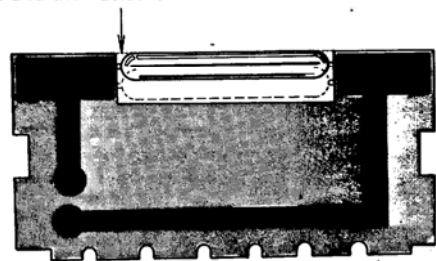

<Fig. 16>

## CHECKING AND ADJUSTING THE AUTO STOP UP MECHANISM

### OPERATION CHECKS

- 1) **Operation check using test record (TRA-001)**
  - There should be no auto operation with band 1 of the P=4 groove.
  - There should be no auto operation with bands 2 and 3 of the P=4 groove.  
Note: The speed shall be set to 33-1/3 rpm.
  - There should be no operation with all bands of the P=1 groove.  
Note: The speed shall be set to 45 rpm.
- 2) **Operation check using record available on market**
  - The pitch of the lead-out groove on an LP is narrow and so use a record upon which a program has been recorded right up to the internal circumference. Check that the auto operation is being performed properly.  
Note: The speed shall be set to 33-1/3 rpm for this test.
  - Use the EP adaptor that comes with the AP-2500 for a record without a middle, and there should be no auto operation while the record is playing.  
Note: The speed shall be set to 45 rpm.

### ADJUSTMENTS

Check that the detection board ass'y and the lamp holder are in their regular positions. (Refer to Fig. 17)  
Turn semi-fixed resistor SFR1 which is used to adjust the CdS sensitivity and adjust the auto operation.

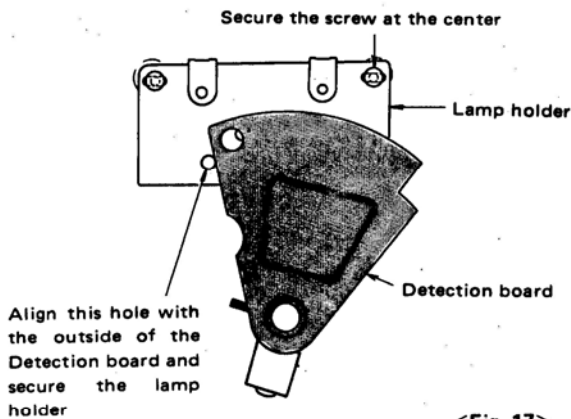

<Fig. 17>

- \* When it is not possible to adjust any more with SFR1  
Note: Return SFR1 to its original position.
- \* When there is auto operation with band 3 but not with band 2:  
Move the lamp holder 0.2 mm in the direction of the arrow and adjust.  
When it is no longer possible to perform the adjustment with the lamp holder, move the detection board ass'y 0.2 mm in the direction of the arrow and adjust. (Refer to Fig. 18)

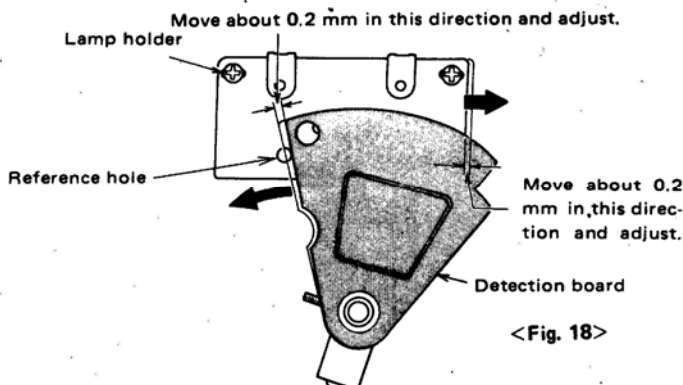

<Fig. 18>

- \* When there is auto operation with bands 1 and 2 but not with band 3:  
Move the lamp holder or the detection board in the opposite direction to that indicated by the arrow, and adjust.  
Note: Move the parts 0.2 mm at a time when adjusting. Do not greatly exceed this value for each move. Make absolutely sure that the adjust screw is locked. Do not bend the detection board ass'y.

### ADJUSTMENTS WHEN REPLACING THE CdS

- \* When there is no auto operation with bands 1, 2 and 3 of the P=4 groove (insufficient sensitivity):
  - Peel off a blind sheet which is attached to the lamp holder and then check the auto operation.
  - If adjustment is still required and if there is a blind sheet from the first, bend the lamp holder so that it is brought close to the CdS. The angle of the bend should be not more than 15°. (Refer to Fig. 19)

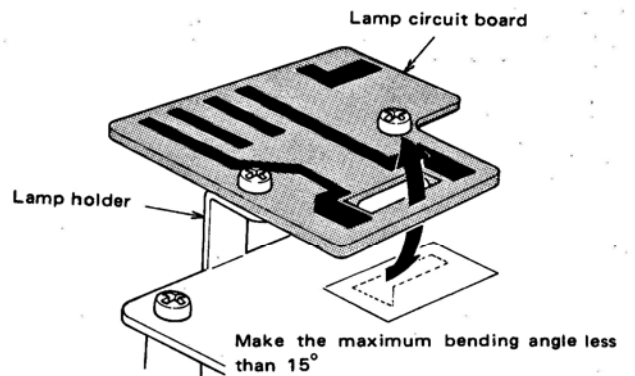

<Fig. 19>

- \* Auto operation with the P=1 groove (excessive sensitivity)
  - Check whether two blind sheets are attached. If there is only one, add another and then check the auto operation. (Refer to Fig. 20)
  - If adjustment is still required, bend the lamp holder away from the CdS. The angle of the bend should not be more than 15°.

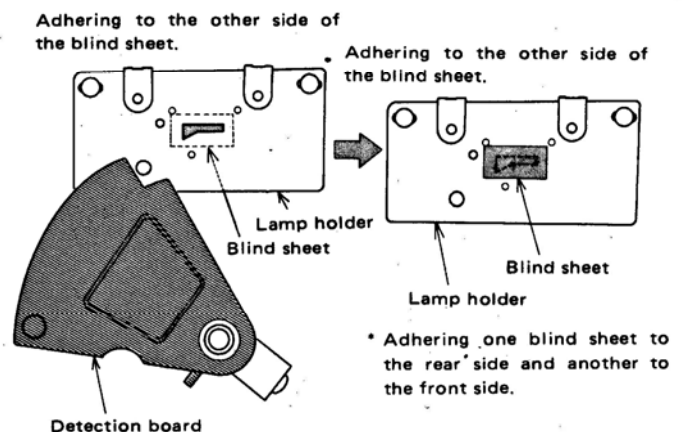

<Fig. 20>

#### Notes

- For fine adjustments, rotate semi-fixed resistor SFR1 which is used for adjusting the CdS sensitivity.
- After the CdS has been replaced, make sure that there are no gaps when the CdS holder is bonded to the lamp holder.

EXPLODED VIEW-1

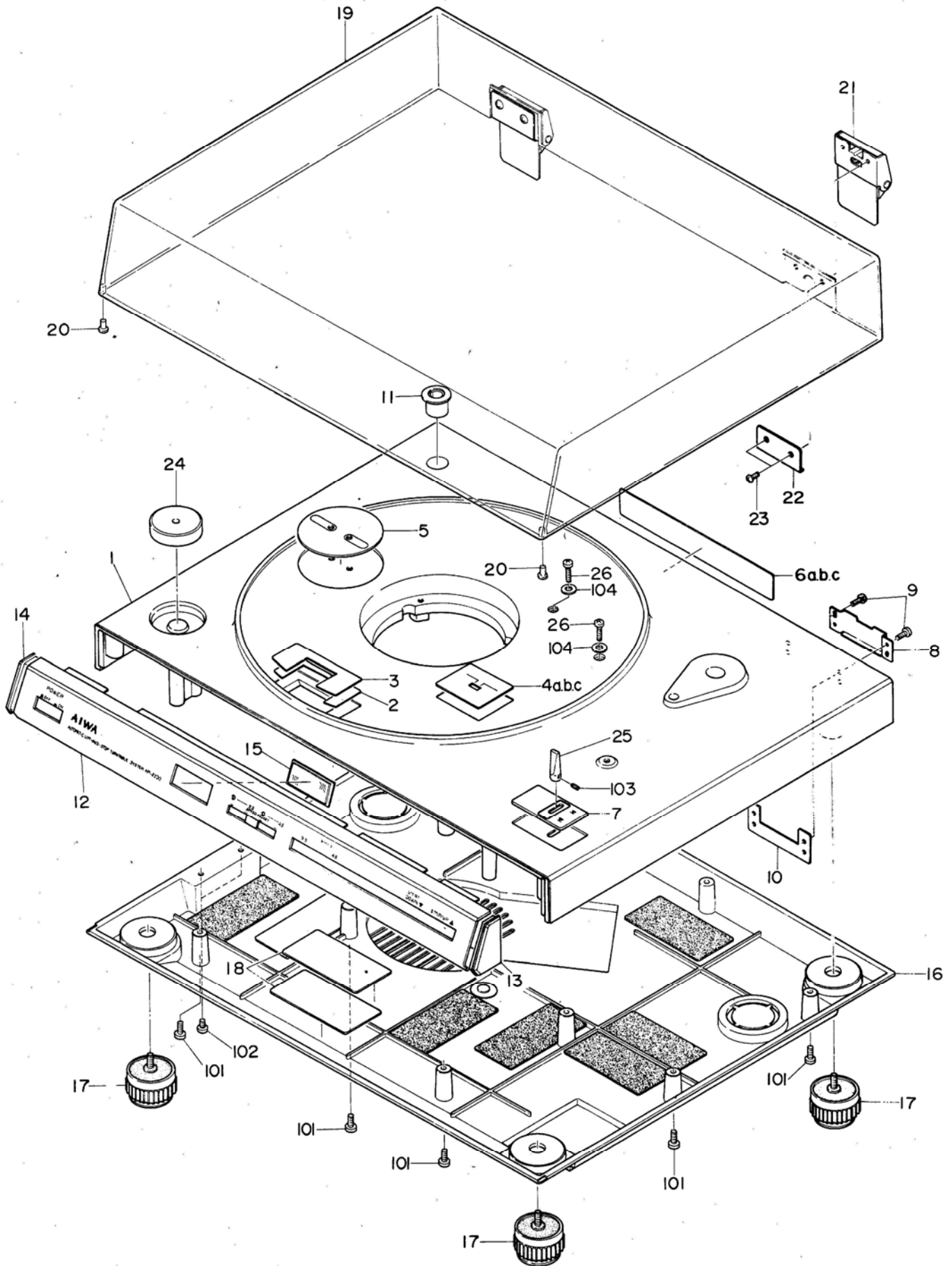

## PARTS LIST

## MECHANICAL PARTS

\* mark in this part list shows exclusive part  
(which is used) for only Model AP-2500.

Ref. No.	Part No.	Part No. Changed to	Description	Common Model	Q'ty
1-1	09-047-075-01		Cabinet case ass'y		1
1-2	84-184-047-01		Adhesive paper	*	1
1-3	84-184-048-01		Label, Strobo	*	1
1-4a	84-184-109-01		Name plate, Voltage selector (H model only)	*	1
1-4b	84-184-105-01		Name plate, Voltage selector (EE model only)	*	1
1-4c	84-184-106-01		Name plate, Voltage selector (UK model only)	*	1
1-5	84-184-064-01		Name plate C, Motor	*	1
1-6a	84-184-107-01		Name plate, Spec. (H model only)	*	1
1-6b	84-184-101-01		Name plate, Spec. (EE model only)	*	1
1-6c	84-184-102-01		Name plate, Spec. (UK model only)	*	1
1-7	84-184-062-01		Rifter plate A	*	1
1-8	84-184-070-01		Lock plate	*	2
1-9	87-257-097-01		U + 3-12 (Black)		8
1-10	84-184-380-01		Holder F, Hinge		2
1-11	84-184-074-01		Stand, Shell	*	1
1-12	84-184-025-01		Panel, Front	*	1
1-13	84-184-018-01		Panel L, Side	*	1
1-14	84-184-026-01		Panel R, Side	*	1
1-15	84-184-014-01		Window, Strobo	*	1
1-16	84-184-002-01		Bottom cabinet	*	1
1-17	84-184-027-01		Rubber foot ass'y	*	4
1-18	84-184-073-01		Dumping sheet	*	10
1-19	84-184-022-01		Dust cover	*	1
1-20	84-184-092-01		Dumper	*	2
1-21	84-184-023-01		Hinge ass'y	*	2
1-22	84-184-024-01		Plate	*	2
1-23	87-229-170-01		P + 4-8 (Black)		4
1-24	84-184-953-01		Adaptor, 45	*	1
1-25	84-184-075-01		Control knob ass'y	*	1
1-26	87-081-582-01		U + 3-14 (Red)		2

Ref. No.	Part No.	Description	Q'ty
1-101	87-253-096-11	U + 3-10	9
1-102	87-253-094-11	U + 3-6	2

Ref. No.	Part No.	Description	Q'ty
1-103	87-360-070-01	SSH2.6-3	1
1-104	87-081-017-01	FW3-8-1	2



EXPLODED VIEW-2

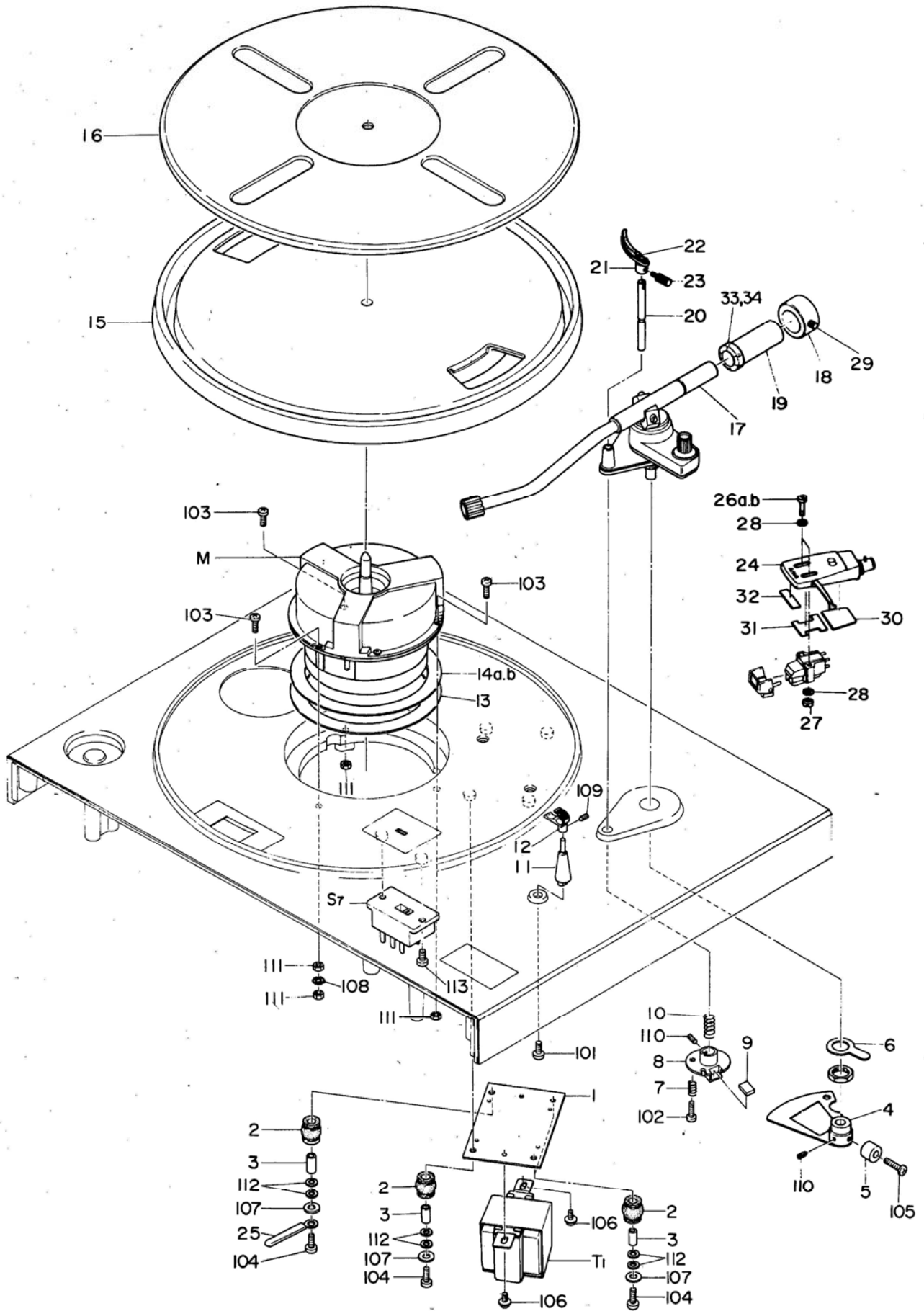

Ref. No.	Part No.	Part No. Changed to	Description	Common Model	Q'ty
2-1	84-184-301-01		Holder, Power transform	*	1
2-2	84-184-299-01		Rubber, Motor	*	4
2-3	84-184-345-01		Collar, Motor rubber	*	4
2-4	84-184-296-01		Detection plate ass'y	*	1
2-5	84-184-365-01		Balance weight	*	1
2-6	84-184-411-01		Arm, Lug terminal	*	1
2-7	84-184-418-01		Spring, Holder L	*	2
2-8	84-184-396-01		Holder L, Magent	*	1
2-9	84-184-643-01		Magnet L	*	1
2-10	84-184-398-01		Spring, Rifter	*	1
2-11	84-184-071-01		Base, Rest	*	1
2-12	84-184-066-01		Arm rest ass'y	*	1
2-13	84-184-417-01		Spacer C	*	1
2-14a	84-184-363-01		Spacer A	*	1
2-14b	84-184-364-01		Spacer B	*	1
2-15	84-184-201-01		Turntable	*	1
2-16	84-184-003-01		Rubber, Sheet	*	1
2-17	84-184-079-01		Tonearm ass'y	*	1
2-18	84-184-084-01		Main weight	*	1
2-19	84-184-094-01		Shaft, Counter	*	1
2-20	84-184-276-01		Shaft, Rifter	*	1
2-21	84-184-016-01		Elevation plate ass'y	*	1
2-22	84-184-017-01		Elevation rubber	*	1
2-23	84-184-090-01		Screw	*	1
2-24	84-184-952-01		Head shell ass'y	*	1
2-25	87-038-039-01		Wire binder	*	1
2-26a	84-184-954-01		Screw, Cartridge stopper (H model only)	*	2
2-26b	84-184-974-01		Screw, Cartridge stopper (EE, UK model only)	*	2
2-27	84-184-955-01		Nut	*	2
2-28	84-184-956-01		Washer	*	4
2-29	84-184-093-01		Weight metal fitting ass'y	*	1
2-30	84-184-425-01		Dumper, Shell	*	1
2-31	84-184-426-01		Spacer, Cartridge	*	1
2-32	84-184-424-01		Dumper, Front shell	*	1
2-33	84-184-082-01		Ring, Counter	*	1
2-34	84-184-083-01		Ring, Stopper	*	1

Ref. No.	Part No.	Description	Q'ty
2-101	87-253-096-11	U + 3-10	1
2-102	87-163-081-11	U + 2.6-20	1
2-103	87-263-177-11	U + 4-20	3
2-104	87-253-103-11	U + 3-25	4
2-105	87-253-076-01	U + 2.6-12	1
2-106	87-500-169-11	VF + 4-6	2
2-107	87-410-318-01	W3-15-0.8	4

Ref. No.	Part No.	Description	Q'ty
2-108	87-433-906-01	WTIE-4	1
2-109	87-360-032-01	SSH2-3	1
2-110	87-360-075-01	SSH2.6-10	2
2-111	87-391-036-11	N-4	4
2-112	87-422-305-01	SW-5	8
2-113	87-253-094-11	U + 3-6	2

EXPLODED VIEW-3

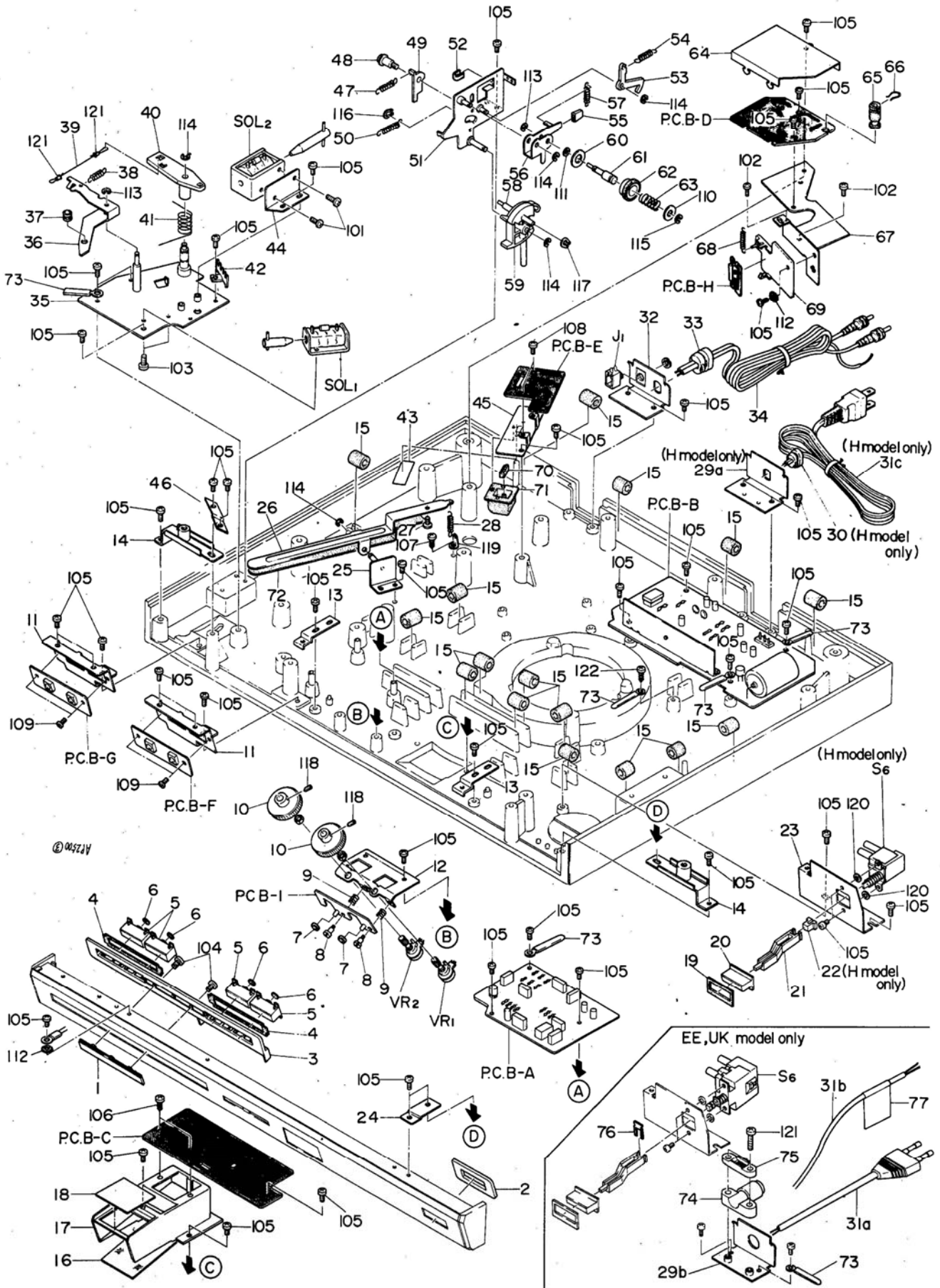

Ref. No.	Part No.	Part No. Changed to	Description	Common Model	Q'ty
3-1	84-184-061-01		Strip, Decorative	*	1
3-2	84-184-377-01		Guide B, Button	*	1
3-3	84-184-376-01		Guide A, Button	*	1
3-4	84-184-389-01		Cushion B, Selector	*	2
3-5	84-184-060-01		Push button A, Selector	*	4
3-6	84-184-373-01		Cushion	*	4
3-7	84-184-395-01		Rubber cushion, Light emitting diode	*	2
3-8	84-184-394-01		Screw, Light emitting diode	*	2
3-9	84-184-361-01		Spring	*	2
3-10	84-184-069-01		Adjuster knob ass'y	*	2
3-11	84-184-374-01		Holder E, Circuit board	*	2
3-12	84-184-375-01		Holder, Volume	*	1
3-13	84-184-355-01		Holder B	*	2
3-14	84-184-243-01		Rubber foot metal fitting ass'y	*	2
3-15	84-184-336-01		Holder, Cord	*	17
3-16	84-184-274-01		Plate, Pilot	*	1
3-17	84-184-273-01		Guide, Strobe	*	1
3-18	84-184-038-01		Acryl mirror	*	1
3-19	84-184-400-01		Cushion C, Power	*	1
3-20	84-184-065-01		Push button B	*	1
3-21	84-184-379-01		Push rod	*	1
3-22	84-184-416-01		Holder Q (H model only)	*	1
3-23	84-184-378-01		Holder J, Switch	*	1
3-24	84-184-381-01		Holder G, Front panel	*	1
3-25	84-184-263-01		Seesaw brass post ass'y	*	1
3-26	84-184-266-01		Seesaw	*	1
3-27	82-331-107-01		Screw for thrust	*	1
3-28	84-184-279-01		Spring, Rifter	*	1
3-29a	84-184-317-01		Holder D, Cord (H model only)	*	1
3-29b	84-184-433-01		Holder D cord ass'y (EE, UK model only)	*	1
3-30	87-085-101-01		Cord bushing (H model only)	*	1
3-31a	87-034-835-01		AC cord (EE model only)	*	1
3-31b	87-034-848-01		AC cord (H model only)	*	1
3-31c	87-034-826-01		AC cord (UK model only)	*	1
3-31	87-034-866-01		AC cord D	*	1
3-32	84-184-382-01		Holder H, Cord	*	1
3-33	84-184-649-01		PU cord holder	*	1
3-34	84-184-618-01		Pin cord	*	1
3-35	84-184-366-01		Sub-chassis ass'y	*	1
3-36	84-184-332-01		Up lever	*	1
3-37	84-184-385-01		Rubber C	*	1
3-38	84-184-337-01		Spring, Up lever	*	1
3-39	87-096-083-01		String, Lock plate	*	1
3-40	84-184-370-01		Relay lever A	*	1
3-41	84-184-372-01		Relay T spring	*	1
3-42	87-032-860-01		5P terminal	*	1
3-43	84-184-390-01		Blind sheet	*	1
3-44	84-184-383-01		Holder K, Solenoid	*	1
3-45	84-184-342-01		Holder, Lamp	*	1
3-46	84-184-423-01		Holder R	*	1
3-47	84-184-360-01		Spring, Lock plate D	*	1
3-48	87-081-483-01		Motor screw, M2.6	*	1
3-49	84-184-308-01		Lock plate D	*	1
3-50	84-184-291-01		Spring, Control lever	*	1
3-51	84-184-300-01		Lifter metal fitting ass'y	*	1
3-52	84-184-422-01		G cushion	*	1
3-53	84-184-306-01		Lock plate B	*	1
3-54	84-184-357-01		Spring, Lock plate B	*	1
3-55	84-184-419-01		Cover, Slip lever	*	1
3-56	84-184-235-01		Slip lever	*	1
3-57	84-184-290-01		Spring, Slip lever	*	1
3-58	84-184-420-01		Collar, Control case proper	*	1
3-59	84-184-305-01		Control case proper ass'y	*	1
3-60	82-392-310-01		Felt	AD-6550	1
3-61	84-184-236-01		Shaft, Slip Roller	*	1
3-62	82-392-306-01		FF pulley sub ass'y	AD-6550	1
3-63	84-184-241-01		Plate spring,	*	1
3-64	84-184-619-01		Shield plate A	*	1
3-65	84-184-393-01		Holder, Lead	*	1
3-66	84-184-421-01		Spring, Lead holder	*	1
3-67	84-184-320-01		Micro switch metal fitting ass'y	*	1
3-68	84-184-399-01		Spring, Lead	*	1
3-69	84-184-397-01		Holder M, Lead	*	1
3-70	84-184-388-01		Cover, CDS	*	1
3-71	84-184-343-01		Holder C, CDS	*	1
3-72	80-180-427-01		Cushion D	*	1
3-73	87-038-039-01		Wire binder	*	6
3-74	87-085-094-01		Holder A, AC cord (EE, UK model only)	*	1
3-75	87-085-095-01		Holder B, AC cord (EE, UK model only)	*	1
3-76	82-385-383-01		Stopper, Rod (EE, UK model only)	*	1
3-77	87-056-016-01		Tag, Main voltage (UK model only)	*	1

**SCHEMATIC DIAGRAM - H MODEL**

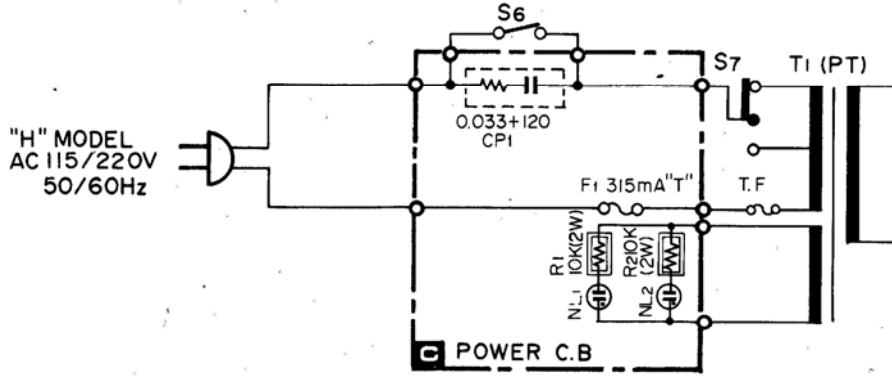

**WIRING - H MODEL**

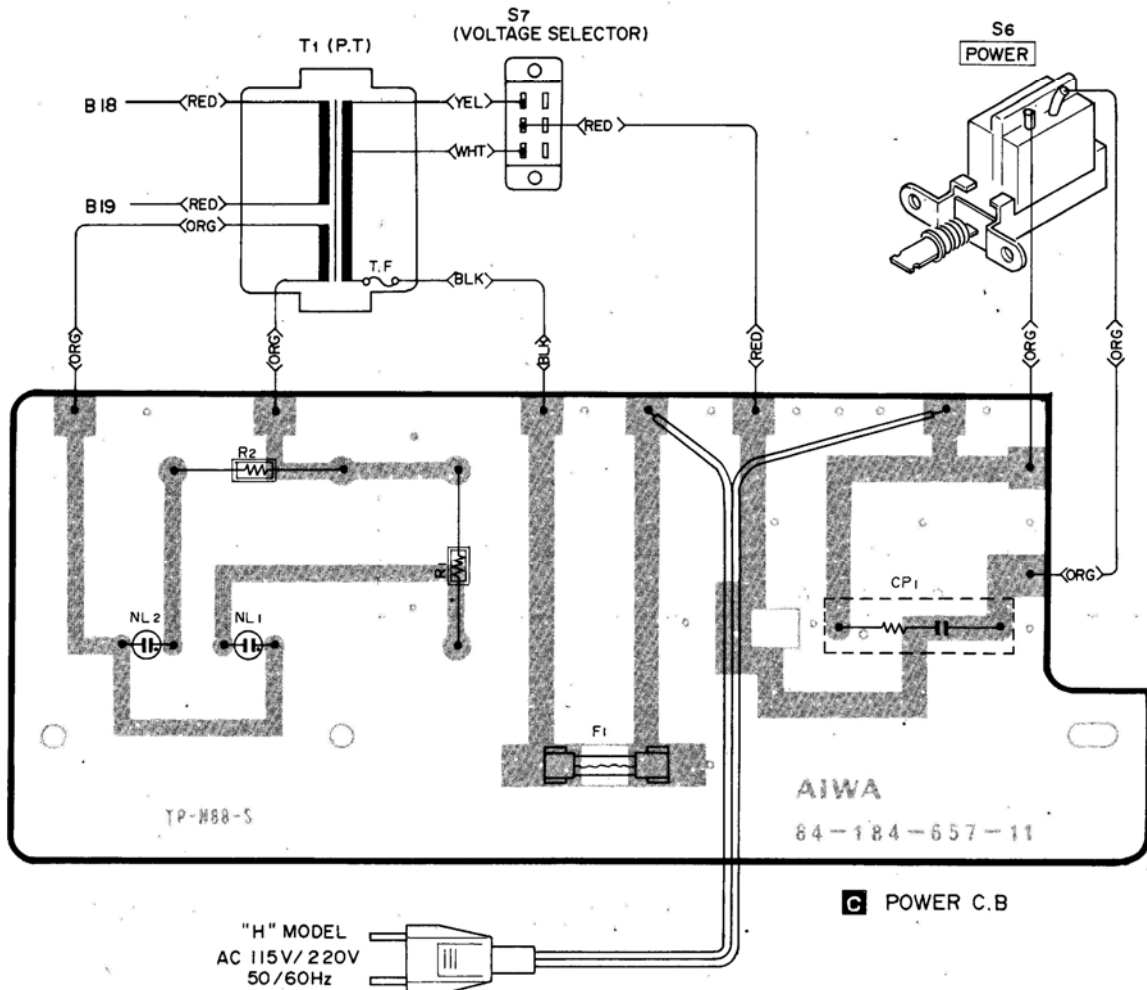

## ELECTRICAL MAIN PARTS LIST

Symbol No.	Part No.	Description
<b>« TOUCH SWITCH CIRCUIT BOARD SECTION »</b>		
PCB-A	84-184-624-11	Touch switch circuit board
Q1,4,6	89-309-456-01	Transistor, 2SC945L (P)
Q2	89-312-222-01	Transistor, 2SC1222 (E)
Q3	89-107-336-01	Transistor, 2SA733 (P)
Q5,7	89-205-623-01	Transistor, 2SB562 (C)
D1	87-027-097-01	Diode, 1S1555
D2,3,4,5	87-027-219-01	Diode, MA150
D6	87-027-215-01	Zener diode, WZ-130
D7,8	87-027-083-01	Diode, 1S1885
RY1	84-184-626-01	Relay
Pin-1,2,3	87-032-773-01	Pin, 3P
	87-032-863-01	Pin, 2P
	87-032-862-01	Pin, 3P
	87-032-861-01	Pin, 4P
		< Resistor >
R1,7	87-025-098-01	1.5k $\Omega$ 1W Nonflammable resistor
		< Capacitors >
C5,8	87-015-291-01	10 $\mu$ F 50V Aluminum solid
C1	87-015-360-01	22 $\mu$ F 35V Tantalun
<b>« MAIN CIRCUIT BOARD SECTION »</b>		
PCB-B	84-184-603-21	Main circuit board
Q1,2,3,4,8, 9,10,11 12,13,14	89-309-456-01	Transistor, 2SC945L (P)
Q5,6,7	89-107-336-01	Transistor, 2SA733 (P)
Q9	89-205-623-01	Transistor, 2SB562 (C)
Q15	89-402-344-01	Transistor, 2SD234 (Y)
D1,2,3,4, 5,6,7,9, 10,11,12,13	87-027-219-01	Diode, MA150
D8	87-027-097-01	Diode, 1S1555
D14	82-385-622-01	Zener diode, WZ-210
D15	87-027-163-01	Diode, 1B4B1
L1	82-346-611-31	Choke coil
RY1	84-184-626-01	Relay
Pin-4	87-032-773-01	Pin, 3P
SFR1	87-021-366-01	Semi-fixed resistor, 10k $\Omega$ -B
	87-032-863-01	Pin, 2P
	87-032-862-01	Pin, 3P
	87-032-861-01	Pin, 4P
		< Resistors >
R13	87-025-068-01	680 $\Omega$ 1W Metal film resistor
R19	87-025-099-01	82 $\Omega$ 1/4W Fuse resistor
		< Capacitors >
C8	87-015-290-01	4.7 $\mu$ F 50V Aluminum solid
C7	87-015-360-01	10 $\mu$ F 50V Aluminum solid
C2	87-015-344-01	6.8 $\mu$ F 25V Tantalun
C1	87-015-345-01	10 $\mu$ F 25V Tantalun
<b>« POWER CIRCUIT BOARD SECTION »</b>		
PCB-C	84-184-657-11	Power circuit board (H model only)
PCB-C	84-184-646-01	Power circuit board (EE, UK model only)
NL1,2	84-184-602-01	Neon lamp
F1	87-035-107-01	Fuse, 315mA "T" (H, EE model only)

Symbol No.	Part No.	Description
F1	87-035-187-01	Fuse, 315mA "T" (UK model only)
	87-098-011-01	Fuse label, 315 mA "T" (UK model only)
	87-032-527-01	Fuse clamp
CP1	87-019-081-01	Combination parts (H model only)
		< Resistor >
R1,2	84-184-621-01	10k $\Omega$ 2W $\pm$ 5% Nonflammable resistor
		< Capacitor >
C1,2	84-190-622-01	0.1 $\mu$ F 250V PME (EE; UK model only)
<b>« RELAY CIRCUIT BOARD SECTION »</b>		
PCB-D	84-184-614-01	Relay circuit board
D1	87-027-097-01	Diode, 1S1555
RY1	84-184-612-01	Relay
<b>« LAMP CIRCUIT BOARD SECTION »</b>		
PCB-E	84-184-625-11	Lamp circuit board
CDS	84-184-615-01	CDS, MKY-7C38AW
PL1	84-184-617-01	Pilot lamp 12V 150mA
		< Resistor >
R1	87-025-107-01	150 $\Omega$ 5W Cement resistor
<b>« SWITCH-1 CIRCUIT BOARD SECTION »</b>		
PCB-F	84-184-623-01	Switch-1 circuit board
S1,2	87-031-394-01	Push switch (33, 45)
<b>« SWITCH-2 CIRCUIT BOARD SECTION »</b>		
PCB-G	84-184-623-01	Switch-2 circuit board
S3,4	87-031-394-01	Push switch (STOP/UP, START/DOWN)
<b>« READ SWITCH CIRCUIT BOARD SECTION »</b>		
PCB-H	84-184-647-11	Read switch circuit board
S5	84-184-642-01	Read switch *
<b>« LED CIRCUIT BOARD SECTION »</b>		
PCB-I	84-184-611-01	LED circuit board
D1,2	87-026-089-01	Light emitting diode, SEL-102R (RED) (45, 33)
<b>« MISCELLANEOUS »</b>		
T1	84-184-662-01	Power transformer (H model only)
T1	84-184-641-01	Power transformer (EE model only)
T1	84-184-660-01	Power transformer (UK model only)
J1	82-422-612-11	Jack 2.5 $\phi$ (REC SYNC)
S6	87-031-400-01	Push switch (POWER) (H model only)
S6	87-031-408-01	Push switch (POWER) (EE, UK model only)
S7	87-031-364-01	Slide switch (VOLTAGE SELECTOR)
VR1,2	84-184-610-01	Volume, 10k $\Omega$ -B (45, 33) (SPEED ADJUST)
SOL1	84-184-616-21	Plunger (UP)
SOL2	84-184-661-01	Plunger (DOWN)
M	84-184-609-01	Motor, DC-EG
CON-1	84-184-648-01	Connector ass'y, 3P
CON-2	84-184-636-01	Connector ass'y, 3P
CON-3,4	84-184-632-11	Connector ass'y, 3P

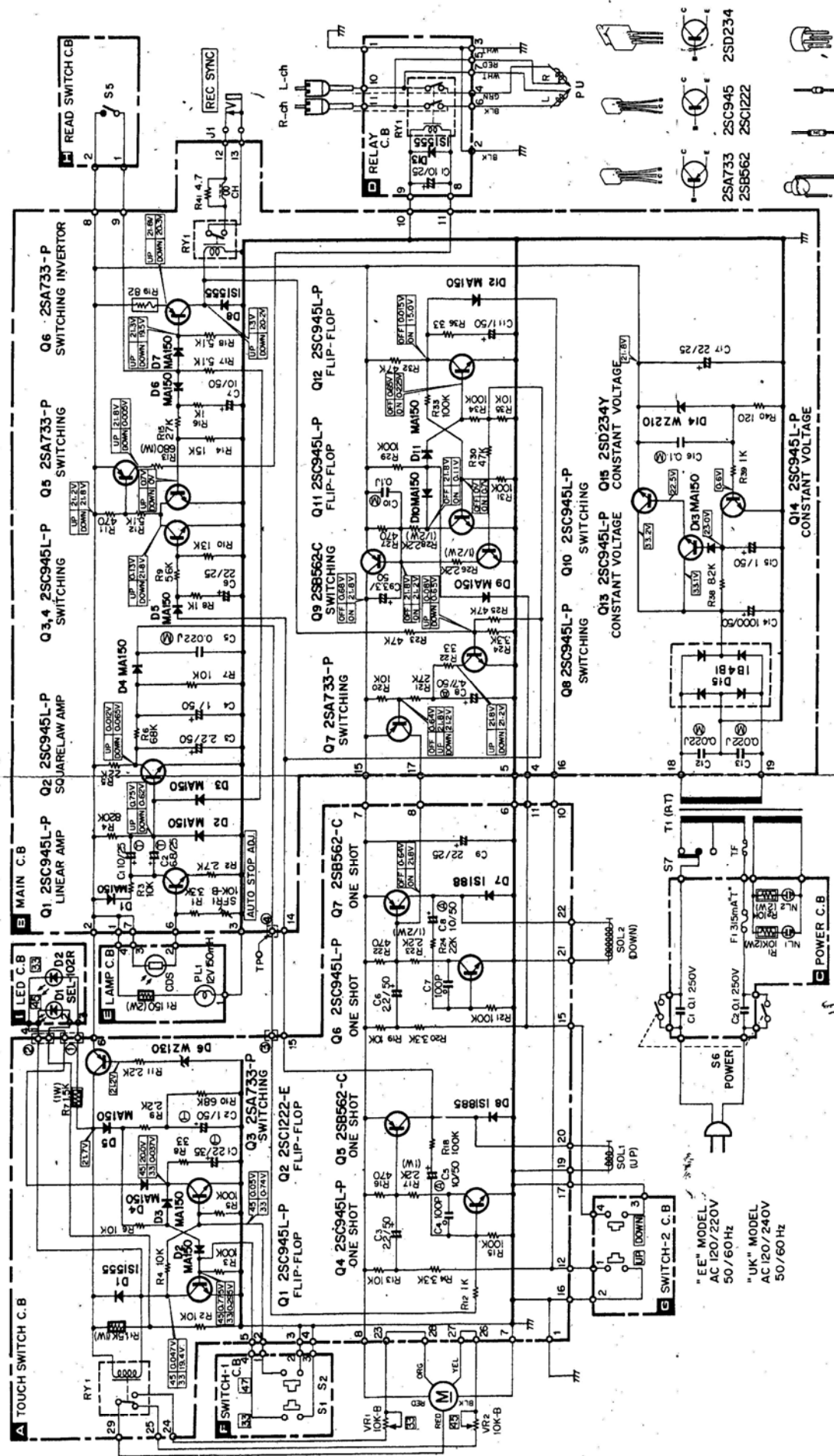

**NOTE:**

- The voltage is the reference value which has been measured with a tester (50 k-ohms/V, DC). However, it should be borne in mind that there are numerous switching circuits and so the voltage often fluctuates noticeably in accordance with the operation state. The voltage display indicates the following operation states:  
 ON ..... Platter is rotating  
 OFF ..... Platter has stopped (POWER-OFF)  
 UP ..... Arm lifter is "UP" when the platter is rotating  
 DOWN ..... Arm lifter is "DOWN" when the platter is rotating  
 "33" ..... Platter is rotating at speed of 33-1/3 rpm  
 "45" ..... Platter is rotating at speed of 45 rpm  
 Resistors with no designation have a rated power of 1/8W and a tolerance of ±5%.
- Capacitors with no designation have a dielectric strength of less than 500WV.  
 Ceramic capacitor symbols:  
 S1-J For temperature compensation (SL)  
 The only capacitor tolerances indicated are ±5% (J) and ±10% (K).  
 Explanation of symbols  
 M Mylar capacitor  
 T Tantalum capacitor  
 A Aluminum solid capacitor  
 This schematic diagram is subject to change without notice in the interests of improved performance.

3) Capacitors with no designation have a dielectric strength of less than 500WV.  
 4) Ceramic capacitor symbols:  
 S1-J For temperature compensation (SL)  
 5) The only capacitor tolerances indicated are ±5% (J) and ±10% (K).  
 6) Explanation of symbols  
 M Mylar capacitor  
 T Tantalum capacitor  
 A Aluminum solid capacitor  
 This schematic diagram is subject to change without notice in the interests of improved performance.

- SELO2R MA150 WZ210 IB4BI
- IS1885 WZ130
- IS1555

- S1 SPEED (33)
- S2 SPEED (45)
- S3 STOP/UP
- S4 START/DOWN
- S5 DETECTION SWITCH
- S6 POWER
- S7 VOLTAGE SELECTOR

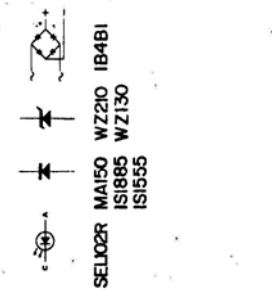

- 2SA733
- 2SB562
- 2SC945
- 2SC1222
- 2SD234

1 2 3 4 5 6 7 8 9 10 11 12 13 14 15

A B C D E F G H I J

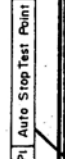
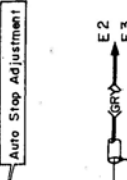
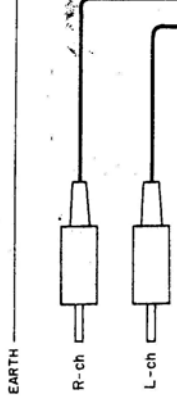
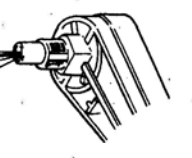
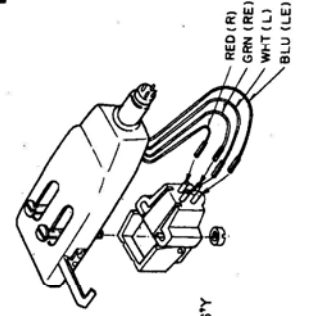
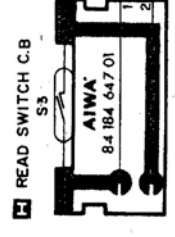
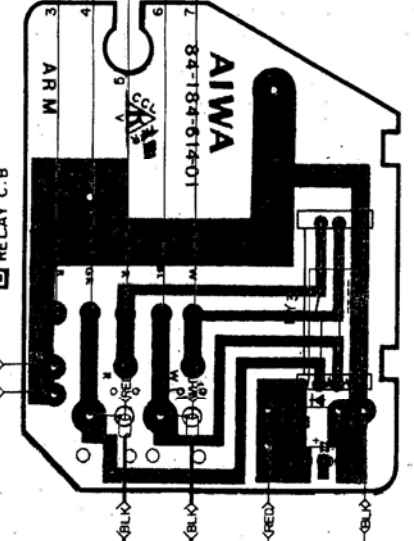
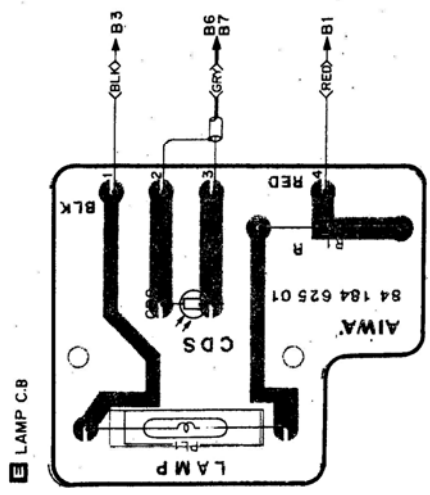
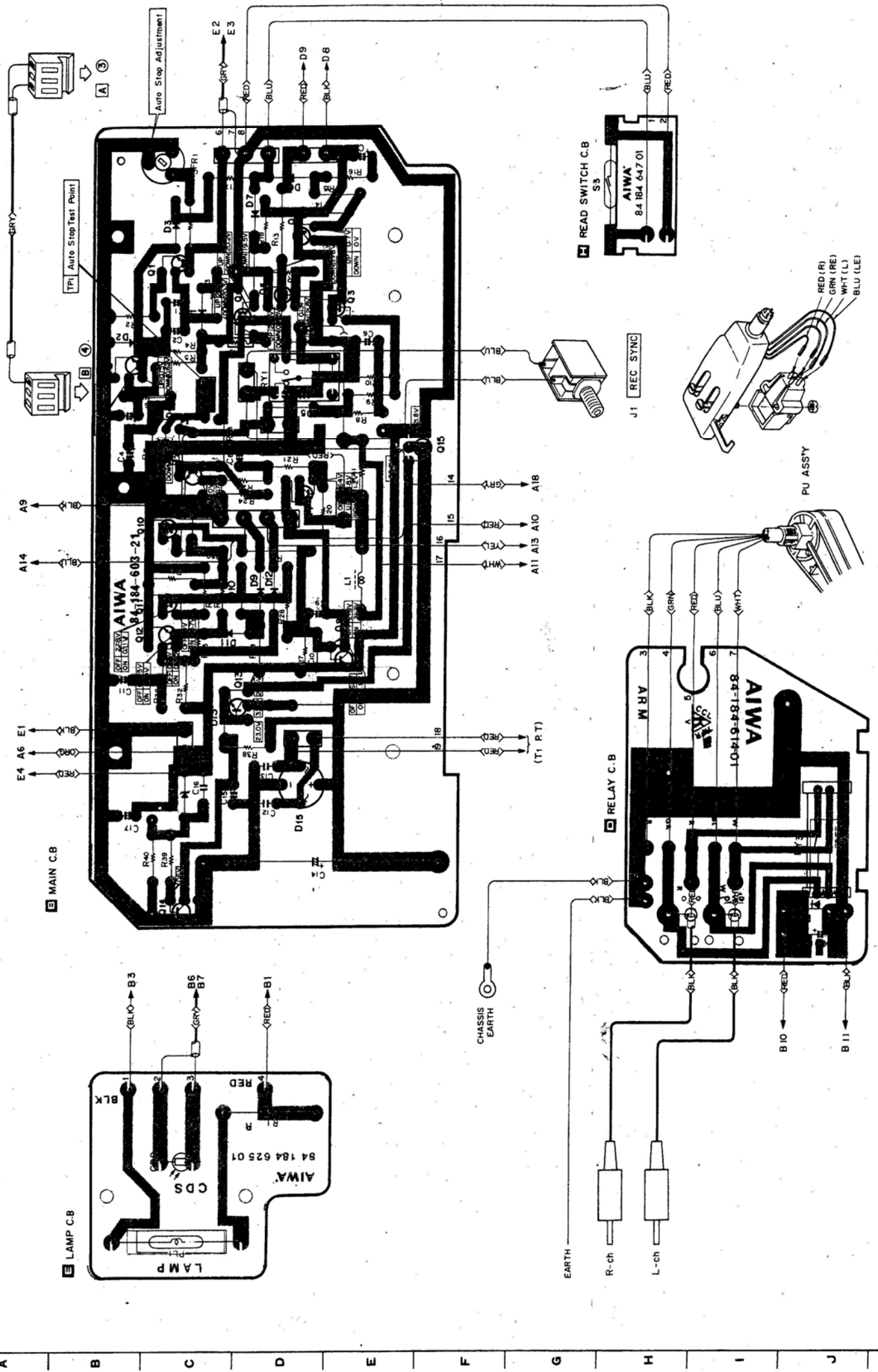



1 2 3 4 5 6 7 8 9 10 11 12 13 14 15

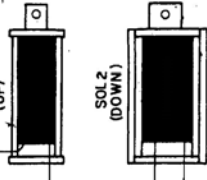
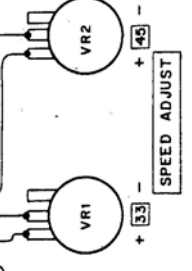
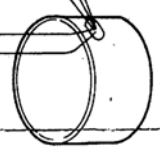
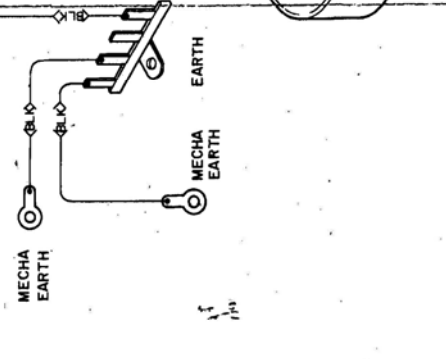
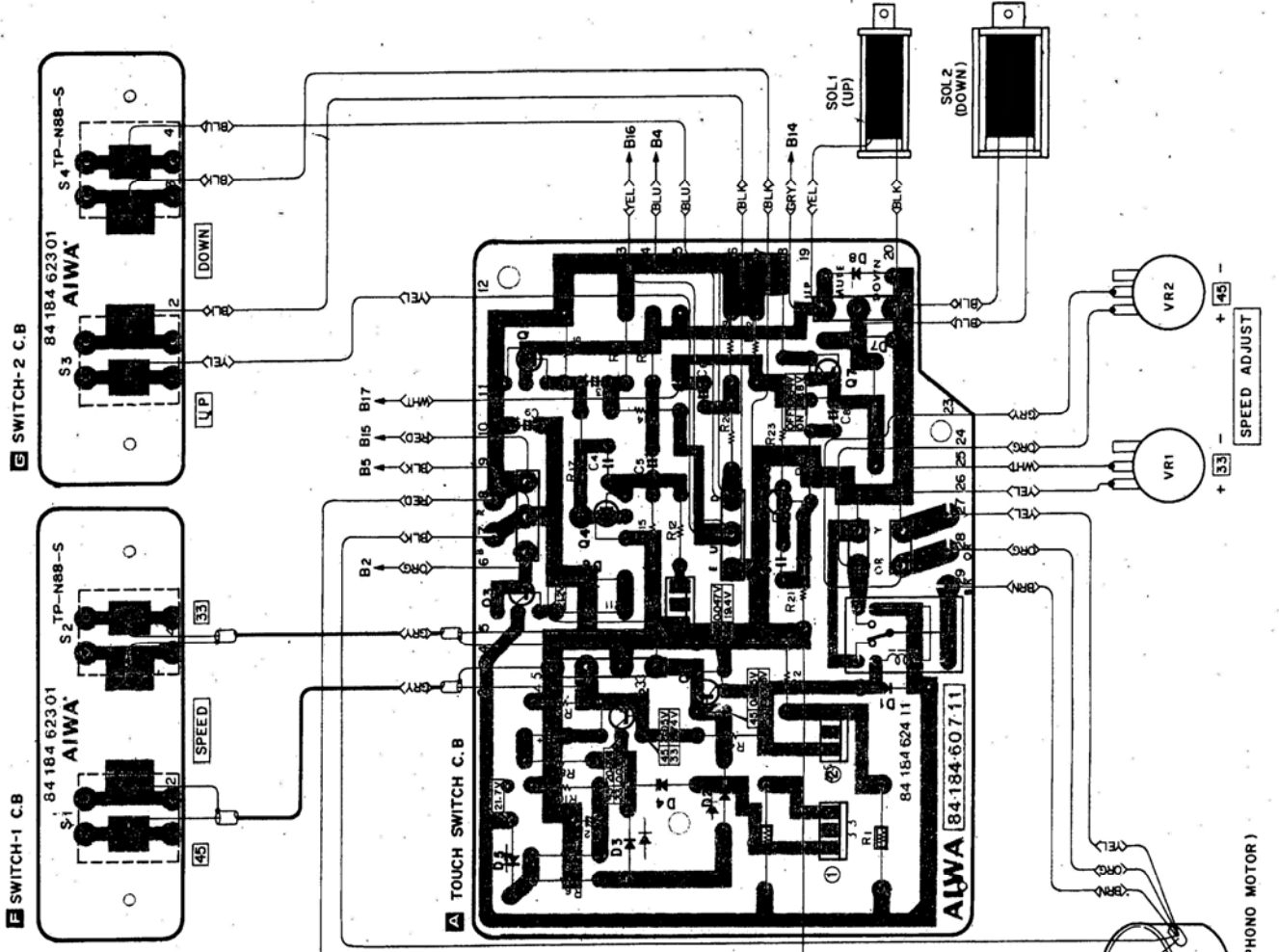
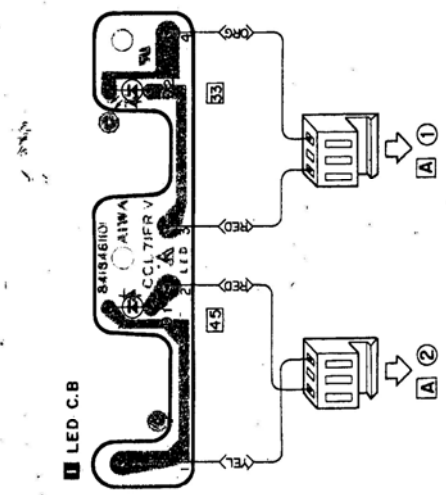
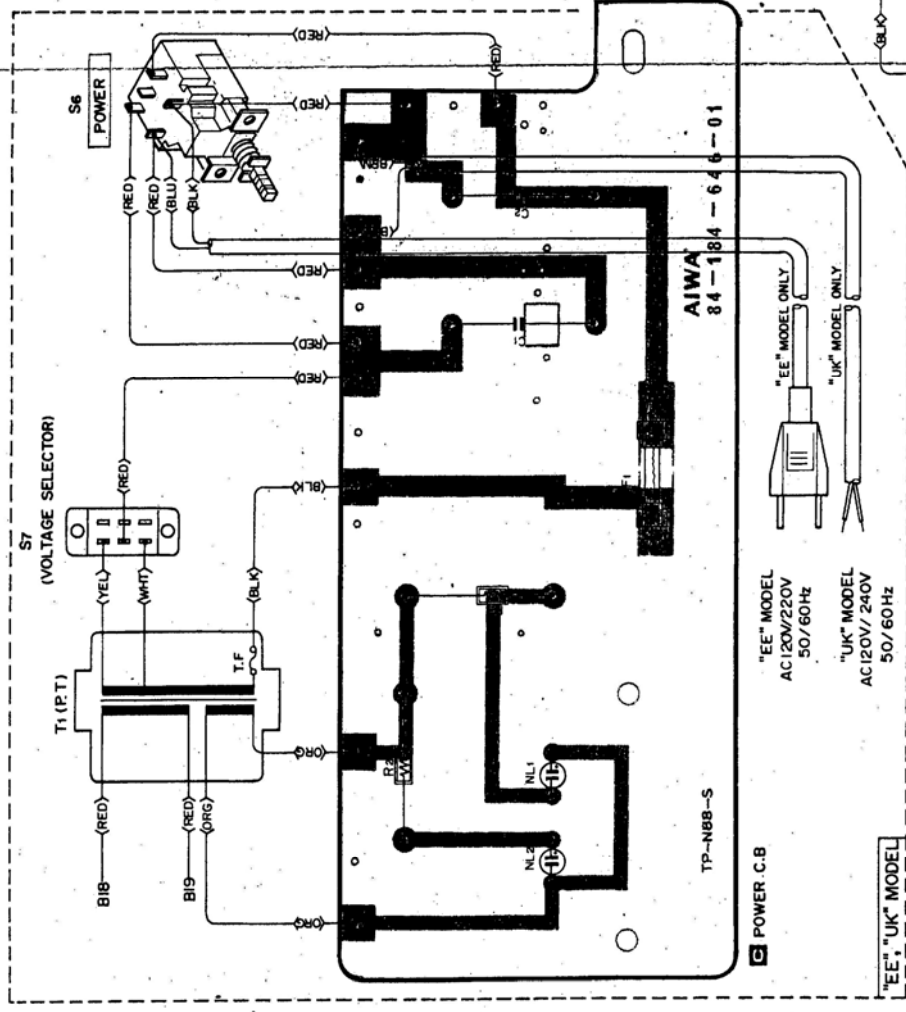

---

**AIWACO.,LTD.**