

aiwa

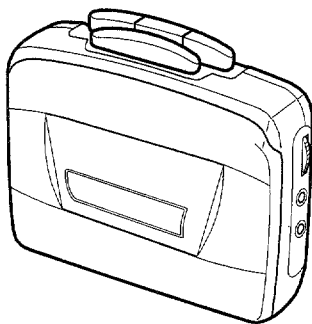

HS-PS152 HS-PS153



STEREO CASSETTE PLAYER

• BASIC TAPE MECHANISM: 4ZM-2 P1NC

• TYPE: Y, YH, YJ, YK, YU(152)
Y(153)

SPECIFICATIONS

Maximum output:	20 mW + 20 mW (EIAJ 16 Ω) 15 mW + 15 mW (EIAJ 32 Ω)
Power source:	DC 3V using two size AA (R6) batteries AC house current using the optional AC adaptor AIWA AC-620/AC-302 (YH only)
Maximum dimensions:	116.6 (W) x 92.0 (H) x 33.8 (D) mm (4 $\frac{3}{8}$ x 3 $\frac{3}{8}$ x 1 $\frac{3}{8}$ in.)
Weight:	Approx. 110 g (3.9 oz) (excluding batteries)

• Design and specifications are subject to change without notice.

MANUAL
SERVICE

ELECTRICAL MAIN PARTS LIST

If can't understand for Description please kindly refer to "REFERENCE NAME LIST".

REF. NO.	PART NO.	KANRI NO.	DESCRIPTION
IC			
	87-A20-855-040		C-IC,TA2069F
MAIN C.B			
C1	87-A10-178-010		CAP,CER 2200P-50 KB
C2	87-A10-178-010		CAP,CER 2200P-50 KB
C6	87-015-681-040		CAP,E 10-16 7L SRA
C7	87-015-681-040		CAP,E 10-16 7L SRA
C10	87-015-676-040		CAP,E 47-6.3 7L SRA
C11	87-A10-489-040		CAP,E 220-4 7L SR
C12	87-A10-489-040		CAP,E 220-4 7L SR
C14	87-015-695-040		CAP,E 1-50 7L SRA
C15	87-018-209-080		CAP,TC U 0.1-50 ZF UP050
C20	87-A10-177-010		CAP,CER 1500P-50 KB
C21	87-A10-177-010		CAP,CER 1500P-50 KB
J1	85-HRL-623-010		JACK,3.5 ST BLK
J2	87-099-375-010		JACK,DC 3.8<YH>
R14	87-A00-330-010		RES,M/F 220-1/8W 3900PPM
SFR1	87-024-197-010		SFR,1K H VZ066L3
SW1	87-A90-133-010		SW,LEAF LSA1120JAU
TH1	87-026-256-090		THMS,HT-100
VR1	87-A90-818-010		VR,RTRY 20KCX2 H XV0102G

ACCESSORIES / PACKAGE LIST

If can't understand for Description please kindly refer to "REFERENCE NAME LIST".

REF. NO.	PART NO.	KANRI NO.	DESCRIPTION
1	88-HKB-907-010		IB,Y-EDPOHCZ-C<152Y,153Y>
1	88-HKB-903-110		IB,Y-EGFSI-C<152YK,152Y,153Y>
1	88-HKB-906-010		IB,YH-ESC-C<152YH>
1	88-HKB-904-010		IB,YJ-ESC-C<152YJ>
1	88-HKB-901-010		IB,YU-ESF-C<152YU>
2	84-447-019-310		CLIP,BELT
3	87-B30-124-010		HEADPHONE,HP-M028<152YU,152YK>
3	87-B30-145-010		HEADPHONE,HP-M029(T)<EXCEPT 152YU,152YK>

ADJUSTMENT

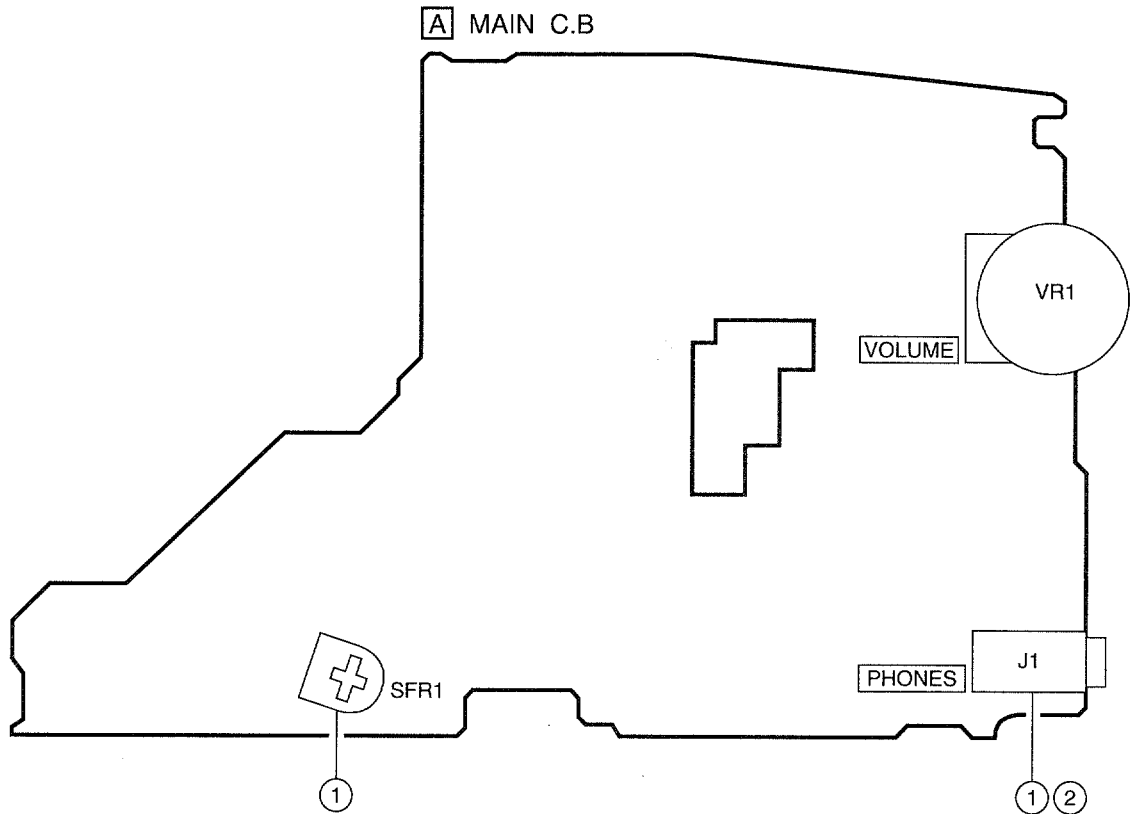

1. Tape Speed Adjustment

- Settings : • Test tape : TTA-100
(TAPE CENTER)
• Test point : PHONES JACK (J1)
• Adjustment location : SFR1

Method : Play back the test tape and adjust for
 $3000\text{Hz} \pm 10\text{Hz}$.

2. Head Azimuth Adjustment

- Settings : • Test tape : TTA-300
• Test point : PHONES JACK (J1)
• Adjustment location : Head azimuth
adjustment screw

Method : Play back the test tape and adjust the screw so
that the output becomes maximum and same
phase.

PRACTICAL SERVICE FIGURE

Tape speed :	3000Hz \pm 60Hz
Wow & flutter :	Less than 0.5% (RMS)
Take-up torque :	35 ~ 50g-cm (FWD)
F.F torque :	More than 30g-cm
Rew torque :	60 ~ 170g-cm
Back tension :	1.5 ~ 4.5g-cm (FWD)
S/N ratio :	More than 43dB (PB, DC)
Distortion :	Less than 3.0% (PB, DC)
Noise level :	Less than 7.0mV (Vol MAX, PB, DC) Less than 0.5mV (Vol MIN, PB, DC)
Frequency response :	63Hz +3dB/-6dB ~ 8kHz \pm 3dB
Test tape :	TTA-100 TTA-210 TTA-320 TTA-330

A MAIN C.B

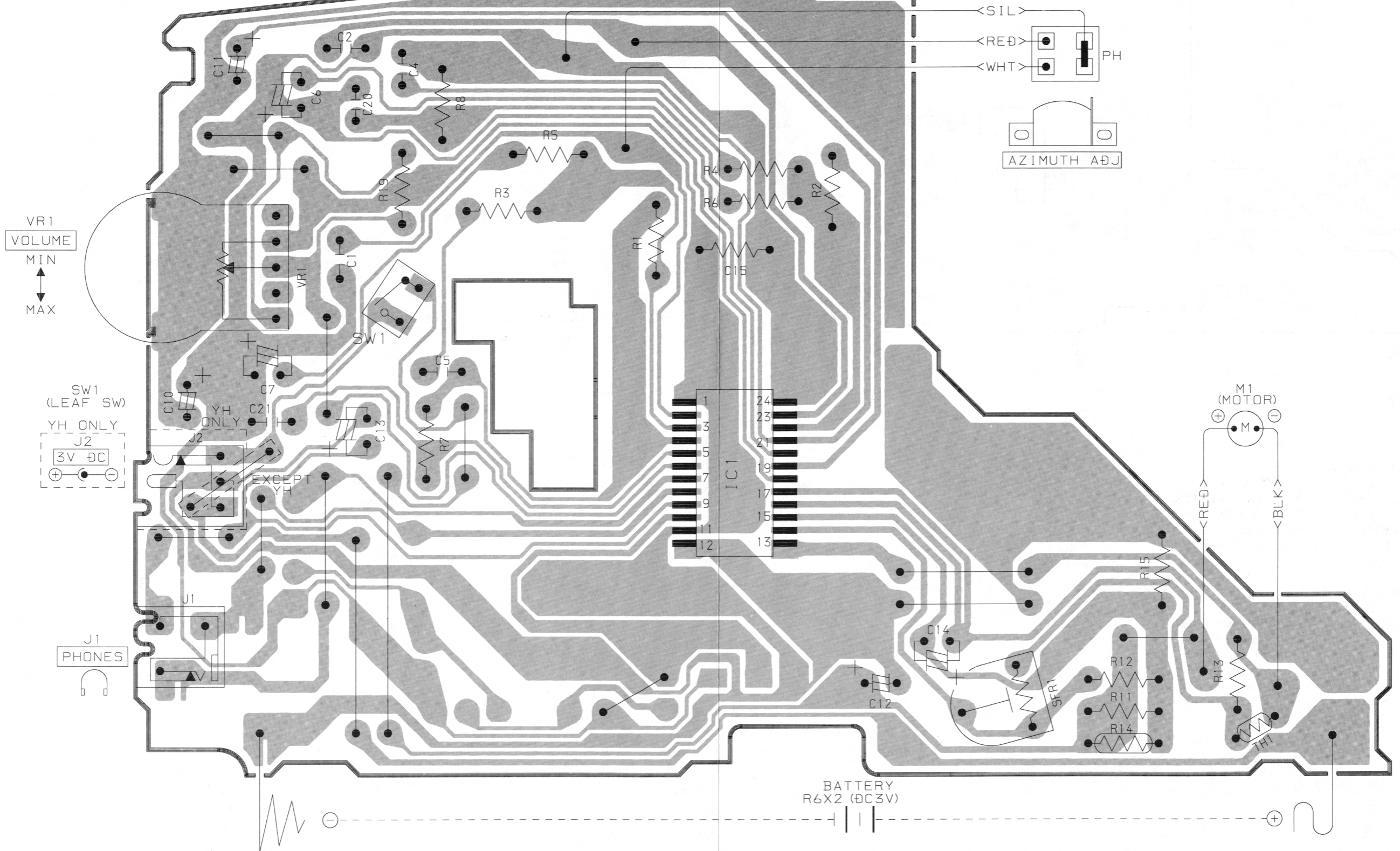

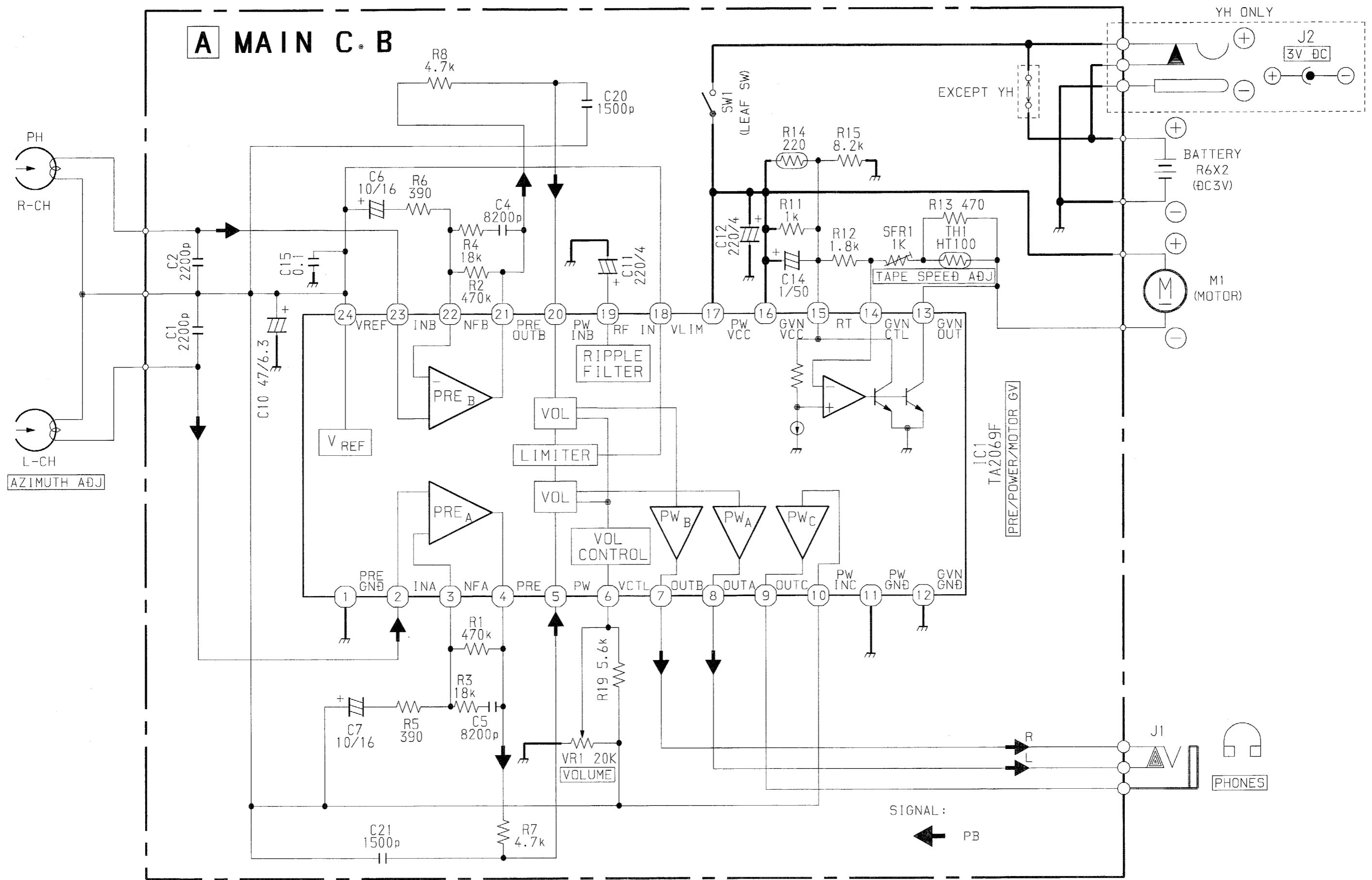

MECHANICAL EXPLODED VIEW 1 / 1

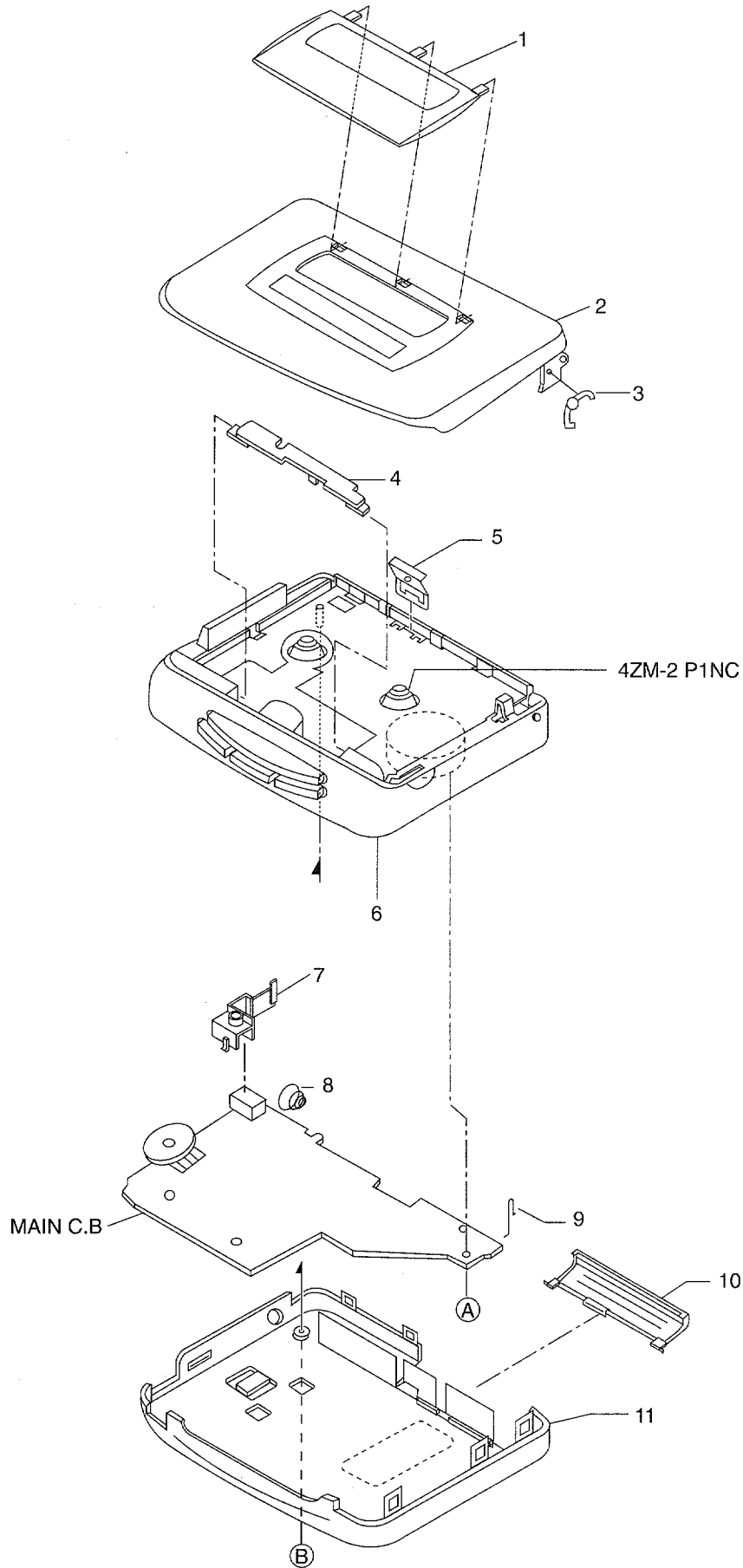

MECHANICAL PARTS LIST 1 / 1

If can't understand for Description please kindly refer to "REFERENCE NAME LIST".

REF. NO.	PART NO.	KANRI NO.	DESCRIPTION
1	88-HKB-002-010		WINDOW, CASS
2	88-HKB-001-010		LID, CASS<EXCEPT 153Y>
2	88-HKB-031-010		LID, CASS 153<153Y>
3	86-HRM-205-010		SPR-T, CLICK
4	87-HRM-201-010		PLATE, HEAD GRAY
5	81-HK9-208-210		SPR-P, CASS A
6	87-HRM-024-010		FRAME, CENTRE GRAY
7	88-HKB-203-010		HLDR, DC JACK<152YH>
7	86-HKA-201-010		HLDR, JACK<EXCEPT 152YH>
8	86-HKA-203-010		BAT-CONTACT, (-)
9	86-HKA-202-010		BAT-CONTACT, (+)
10	88-HKB-034-010		LID, BATT J034
11	88-HKB-033-010		CABI, REAR J034<EXCEPT 152YH>
11	88-HKB-035-010		CABI, REAR YH<152YH>
A	87-264-525-310		SCREW, V+1.7-2.5
B	87-067-691-010		SCREW, VT+1.7-6

TAPE MECHANISM EXPLODED VIEW 1 / 1

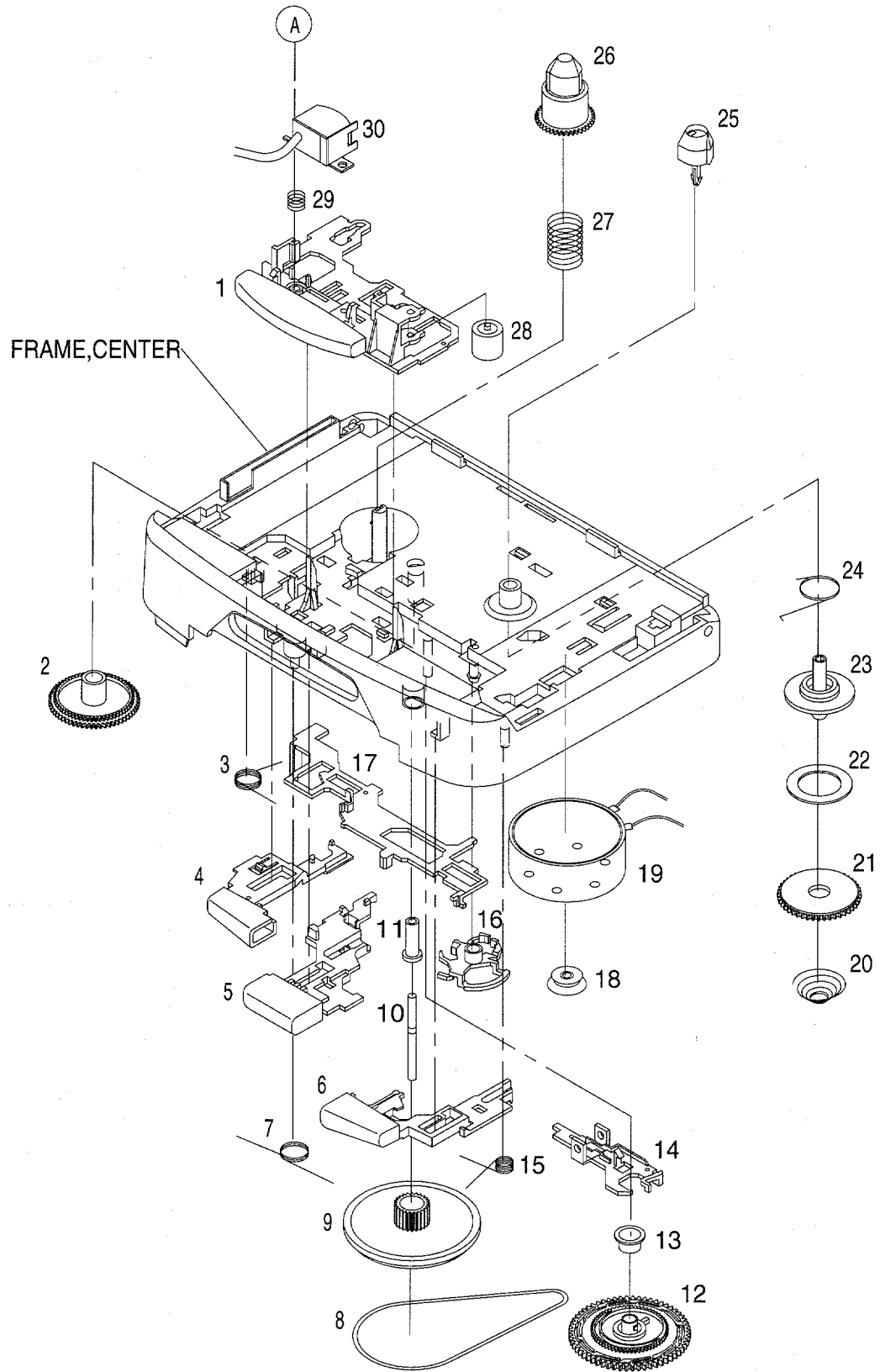

TAPE MECHANISM PARTS LIST 1 / 1

If can't understand for Description please kindly refer to " REFERENCE NAME LIST ".

REF. NO.	PART NO.	KANRI NO.	DESCRIPTION	REF. NO.	PART NO.	KANRI NO.	DESCRIPTION
1	84-ZM2-002-01K		LEVER, PLAY	21	84-ZM2-212-01K		GEAR, CLUTCH
2	84-ZM2-211-01K		GEAR, CONNECT	22	84-ZM2-231-019		FELT, CLUTCH
3	84-ZM2-222-010		SPR-T, PLAY	23	84-ZM2-217-01K		SHAFT, REEL
4	84-ZM2-005-01K		LEVER, STOP	24	84-ZM2-225-010		SPR-T, AUTO FIND
5	84-ZM2-004-01K		LEVER, REW	25	84-ZM2-216-01K		REEL TABLE, R
6	84-ZM2-003-01K		LEVER, FF	26	84-ZM2-215-01K		REEL TABLE, L
7	84-ZM2-223-010		SPR-T, REW STOP	27	84-ZM2-228-010		SPR-C, BT
8	84-ZM2-232-010		BELT, MAIN	28	84-ZM2-233-110		PINCH ROL ASSY
9	84-ZM2-214-01K		FLY-WHL, P	29	84-ZM2-227-010		SPR-C, AZIMUTH
10	84-ZM2-230-010		CAPSTAN, P 1.8-25	30	87-A90-272-010		HEAD, PH MS25P ETH
11	84-ZM2-220-01K		BRG, P	A	84-ZM2-242-019		S-SCREW, AZIMUTH-2-5.9
12	84-ZM2-210-01K		GEAR, AUTO				
13	84-ZM2-218-01K		CAP, GEAR AUTO				
14	84-ZM2-208-01K		LEVER, SHIFT				
15	84-ZM2-224-010		SPR-T, FF LOCK				
16	84-ZM2-207-01K		LEVER, AUTO				
17	84-ZM2-206-01K		LEVER, LOCK				
18	84-ZM2-219-01K		PULLEY, MOTOR				
19	87-045-385-019		MOT (BCY3B11)				
20	84-ZM2-226-010		SPR-C, CLUTCH				

SPRING APPLICATION POSITION

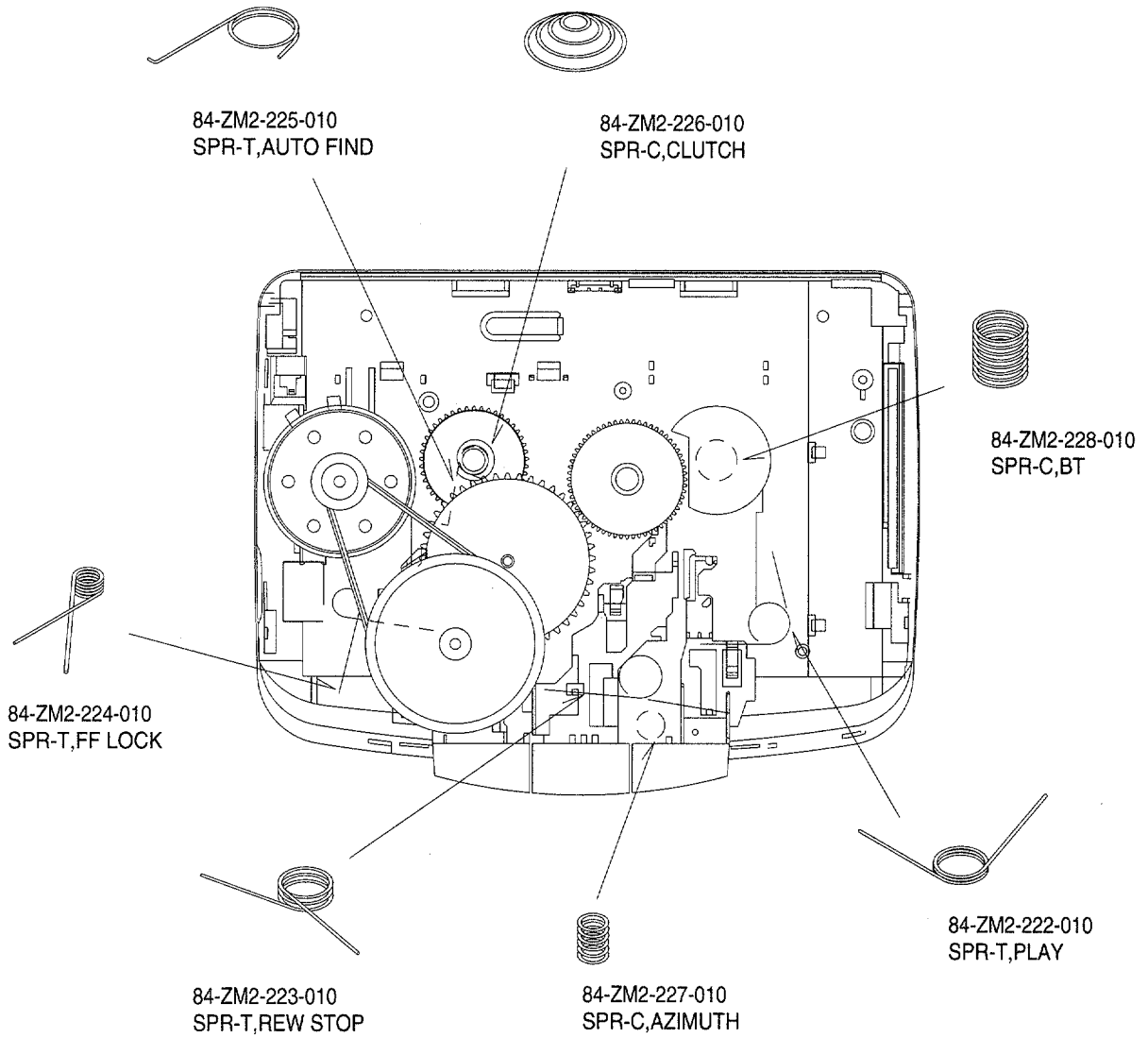

REFERENCE NAME LIST

ELECTRICAL SECTION

DESCRIPTION	REFERENCE NAME
ANT	ANTENNAS
C-	CHIP
C-CAP	CAP, CHIP
C-CAP TN	CAP, CHIP TANTALUM
C-COIL	COIL, CHIP
C-DI	DIODE, CHIP
C-DIODE	DIODE, CHIP
C-FET	FET, CHIP
C-FOTR	FILTER, CHIP
C-JACK	JACK, CHIP
C-LED	LED, CHIP
C-RES	RES, CHIP
C-SFR	SFR, CHIP
C-SLIDE SW	SLIDE SWITCH, CHIP
C-SW	SWITCH, CHIP
C-TR	TRANSISTOR, CHIP
C-VR	VOLUME, CHIP
C-ZENER	ZENER, CHIP
CAP, CER	CAP, CERA-SOL
CAP, E	CAP, ELECT
CAP, M/F	CAP, FILM
CAP, TC	CAP, CERA-SOL
CAP, TC-U	CAP, CERA-SOL SS
CAP, TN	CAP, TANTALUM
CERA FIL	FILTER, CERAMIC
CF	FILTER, CERAMIC
DL	DELAY LINE
E/CAP	CAP, ELECT
FILT	FILTER
FLTR	FILTER
FUSE RES	RES, FUSE
MOT	MOTOR
P-DIODE	PHOTO DIODE
P-SNSR	PHOTO SENSER
P-TR	PHOTO TRANSISTOR
POLY VARI	VARIABLE CAPACITOR
PPCAP	CAP, PP
PT	POWER TRANSFORMER
PTR, RES	PTR, MELF
RC	REMOTE CONTROLLER
RES NF	RES, NON-FLAMMABLE
RESO	RESONATOR
SHLD	SHIELD
SOL	SOLENOID
SPKR	SPEAKER
SW, LVR	SWITCH, LEVER
SW, RTRY	SWITCH, ROTARY
SW, SL	SWITCH, SLIDE
TC CAP	CAP, CERA-SOL
THMS	THERMISTOR
TR	TRANSISTOR
TRIMER	CAP, TRIMMER
TUN-CAP	VARIABLE CAPACITOR
VIB, CER	RESONATOR, CERAMIC
VIB, XTAL	RESONATOR, CRYSTAL
VR	VOLUME
ZENER	DIODE, ZENER

MECHANICAL SECTION

DESCRIPTION	REFERENCE NAME
ADHESHIVE	SHEET ADHESHIVE
AZ	AZIMUTH
BAR-ANT	BAR-ANTENNA
BAT	BATTERY
BATT	BATTERY
BRG	BEARING
BTN	BUTTON
CAB	CABINET
CASS	CASSETTE
CHAS	CHASSIS
CLR	COLLAR
CONT	CONTROL
CRSR	CURSOR
CU	CUSHION
CUSH	CUSHION
DIR	DIRECTION
DUBB	DUBBING
FL	FRONT LOADING
FLY-WHL	FLYWHEEL
FR	FRONT
FUN	FUNCTION
G-CU	G-CUSHION
HDL	HANDOL
HIMERON	CLOTH
HINGE, BAT	HINGE, BATTERY
HLDR	HOLDER
HT-SINK	HEAT SINK
IB	INSTRUCTION BOOKLET
IDLE	IDLER
IND, L-R	INDICATOR, L-R
KEY, CONT	KEY, CONTROL
KEY, PRGM	KEY, PROGRAM
KNOB, SL	KNOB, SLIDE
LBL	LABEL
LID, BATT	LID, BATTERY
LID, CASS	LID, CASSETTE
LVR	LEVER
P-SPRING	P-SPRING
PANEL, CONT	PANEL, CONTROL
PANEL, FR	PANEL, FRONT
PRGM	PROGRAM
PULLY, LOAD MO	PULLY, LOAD MOTOR
RBN	RIBBON
S-	SPECIAL
SEG	SEGMENT
SH	SHEET
SHLD-SH	SHIELD-SHEET
SL	SLIDE
SP	SPRING
SP-SCREW	SPECIAL-SCREW
SPACER, BAT	SPACER, BATTERY
SPR	SPRING
SPR-P	P-SPRING
SPR-PC-PUSH	P-SPRING, C-PUSH
T-SP	T-SPRING
TERM	TERMINAL
TRIG	TRIGGER
TUN	TUNING
VOL	VOLUME
W	WASHER
WHL	WHEEL
WORM-WHL	WORM-WHEEL

サービス技術ニュース	
番号	連絡内容
G- -	
G- -	
G- -	

アイワ株式会社
AIWA CO.,LTD.

9420025, 750038

Tokyo Japan