

SERVICE MANUAL

STEREO CASSETTE PLAYER

BASIC TAPE MECHANISM :4ZM-2 P3NC2

SPECIFICATIONS

Maximum output:	15 mW + 15 mW (EIAJ/32Ω) 4 mW + 4 mW (EIAJ/16Ω)<Y1>
Power source:	DC 3V using two R6 (size AA) dry cell batteries, AC house current using the optional AC adaptor Aiwa AC-D302<YH>
Maximum dimensions:	116.4 (W) X 92.0 (H) X 35.0 (D) mm (4 ⁵ / ₈ x 3 ⁵ / ₈ x 1 ⁷ / ₁₆ in.)
Weight	Approx.110g (3.9 oz) (excluding batteries)

- Design and specifications are subject to change without notice.

ELECTRICAL MAIN PARTS LIST

REF. NO.	PART NO.	KANRI NO.	DESCRIPTION
IC			
	87-A21-144-040		IC,TA2069AF
DIODE			
	87-020-339-080		CHIP DIODE,1SS226
MAIN C.B			
C1	87-010-181-080		CAP,CHIP S 1800P
C2	87-010-181-080		CAP,CHIP S 1800P
C3	87-010-189-080		C-CAP,S 8200-50 B
C4	87-010-189-080		C-CAP,S 8200-50 B
C5	87-015-676-040		E/CAP 47/6.3
C6	87-015-676-040		E/CAP 47/6.3
C7	87-010-180-080		C-CER 1500P
C8	87-010-180-080		C-CER 1500P
C9	87-010-178-080		CHIP CAP 1000P
C10	87-010-178-080		CHIP CAP 1000P
C11	87-A10-489-040		CAP,E 220-4
C12	87-A10-489-040		CAP,E 220-4
C13	87-015-695-040		E/CAP 1UF 50V
C14	87-015-681-040		E/CAP 10-16
C15	87-010-196-080		CHIP CAPACITOR,0.1-25
C16	87-010-805-080		CAP, S 1-16
C17	87-010-805-080		CAP, S 1-16
C18	87-010-805-080		CAP, S 1-16
C401	87-012-141-080		CHIP CAPACITOR,0.22-16F
C402	87-012-141-080		CHIP CAPACITOR,0.22-16F
C403	87-010-196-080		CHIP CAPACITOR,0.1-25
J1	85-HRL-623-010		JACK,3.5 ST BLK
J2	87-A60-849-010		JACK,DC DIA 2.75 BLK <YH>
R12	87-A00-530-080		C-RES,S 180-1/10W
SFR1	87-024-197-010		SEMI-FIXED RESISTOR,1K
SW1	87-A90-133-010		SW LEAF LSA1120JAU
VR1	87-A90-981-010		VR,RTRY 20KBX1
FRONT C.B			
SW401	87-A90-330-080		C-SW,SL 1-1-2 SSSS81

ADJUSTMENT <DECK>

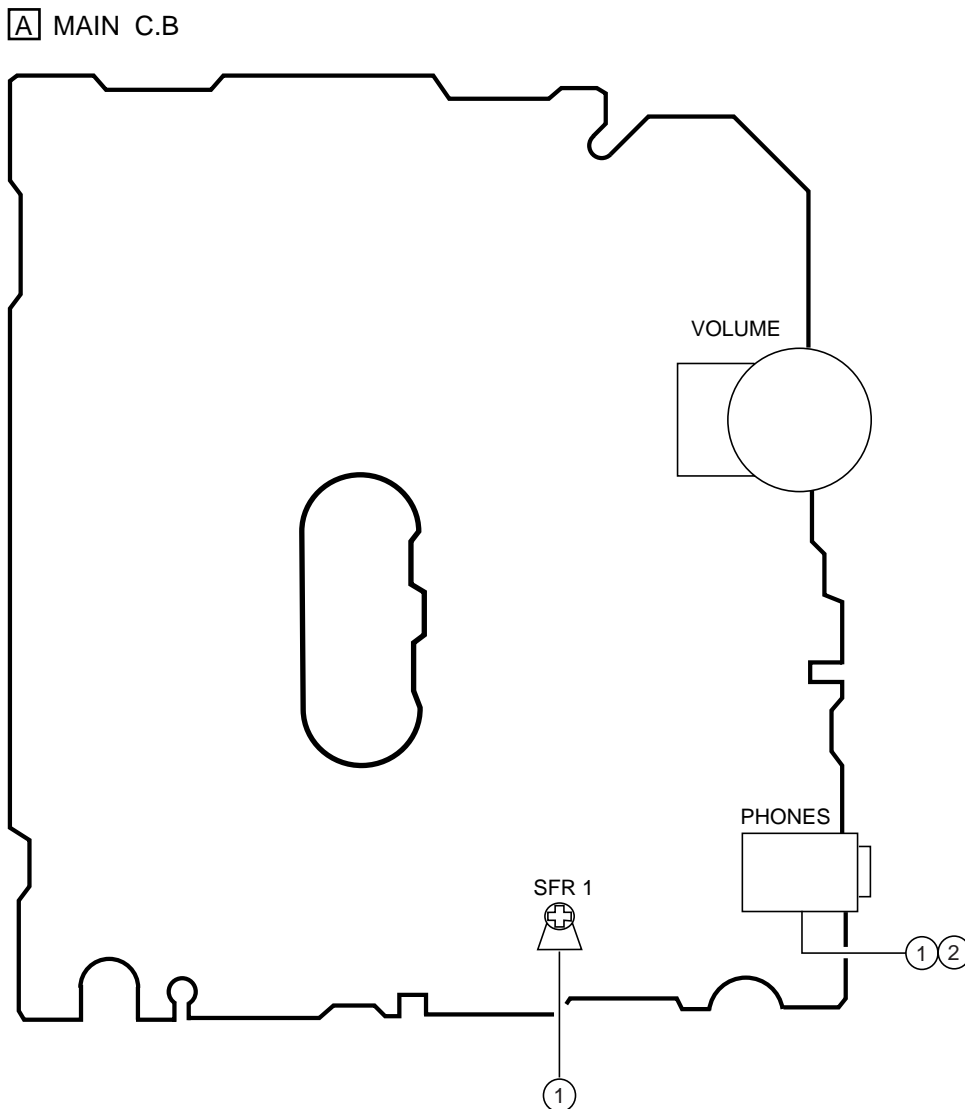

1. Tape Speed Adjustment
 - Settings :
 - Test tape : TTA-100(TAPE CENTER)
 - Test point : PHONES JACK (J1)
 - Adjustment location : SFR1
 - Method : Play back the test tape and adjust SFR1 so that the frequency is $3000\text{Hz} \pm 10\text{Hz}$.

2. Head Azimuth Adjustment
 - Settings :
 - Test tape : TTA-300
 - Test point : PHONES JACK (J1)
 - Adjustment location : Head azimuth adjustment screw
 - Method : Play back the test tape and adjust the screw so that the output becomes maximum and same phase

PRACTICAL SERVICE FIGURE

Tape speed :	$3000\text{Hz} \pm 50\text{Hz}$
Wow & flutter :	Less than 0.5% (RMS)
Take-up torque :	40g-cm (FWD/RVS)
F.F/REW torque :	More than 60g-cm
Back tension :	1.5 ~ 4.5g-cm (FWD/RVS)
S/N ratio :	More than 43dB (PB, DC)
Distortion :	Less than 3.0% (PB, DC)
Noise level :	Less than 7.0mV (Vol MAX, PB, DC)
	Less than 0.5mV (Vol MIN, PB, DC)
Frequency response :	$63\text{Hz} + 2/- 4\text{dB} \sim 8\text{kHz} + 3/- 4\text{dB}$
Test tape :	TTA-210 TTA-320/TTA-310 TTA- 100

WIRING (MAIN/FRONT)

A MAIN C.B

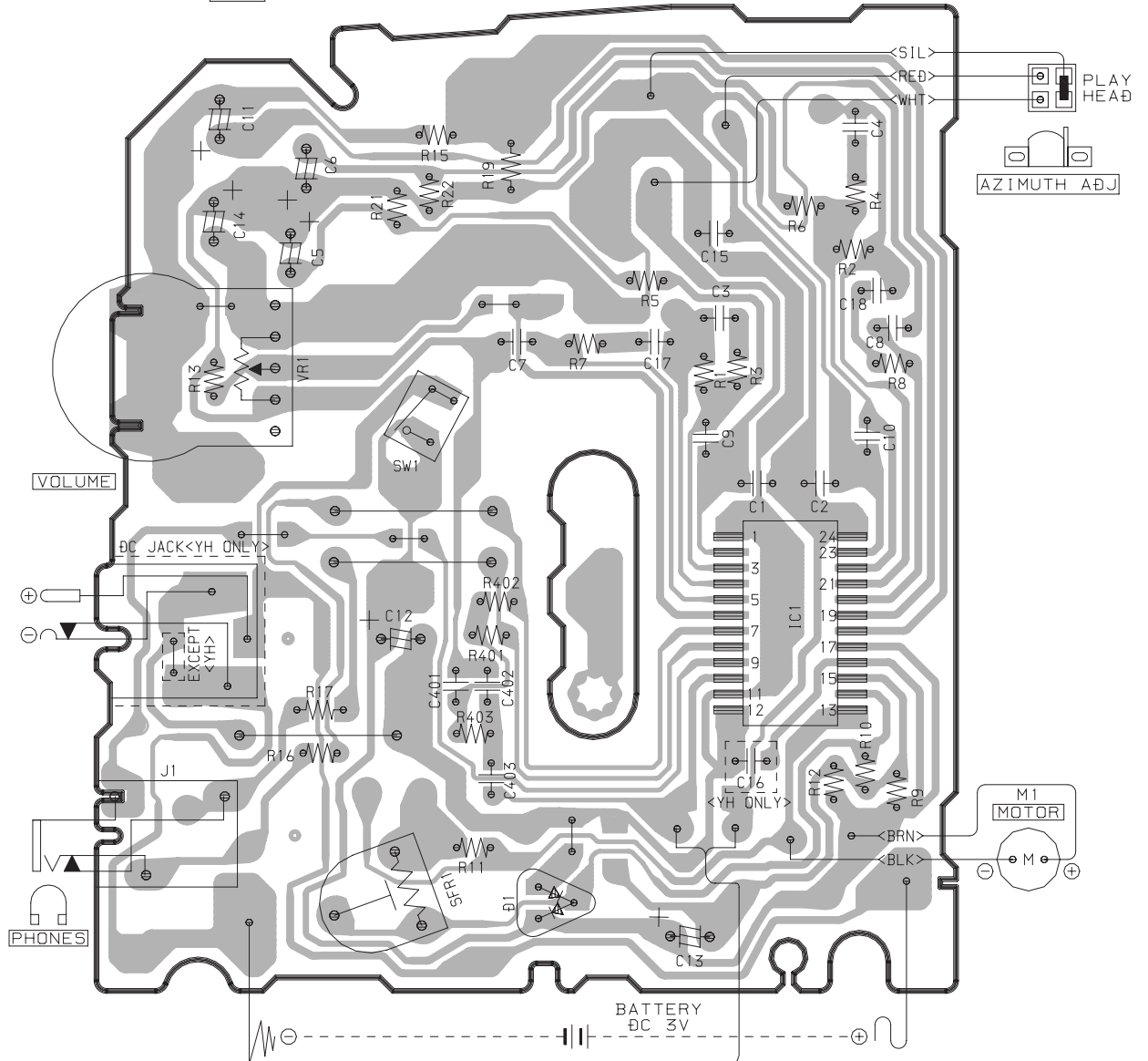

B FRONT C.B

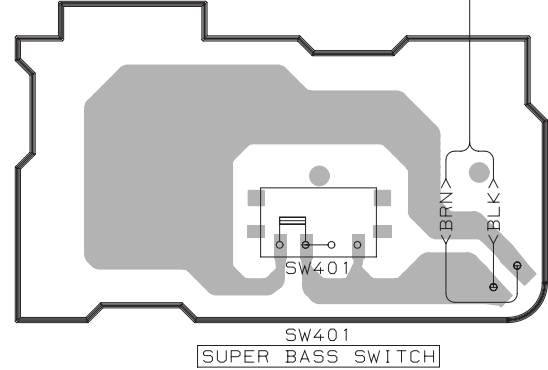

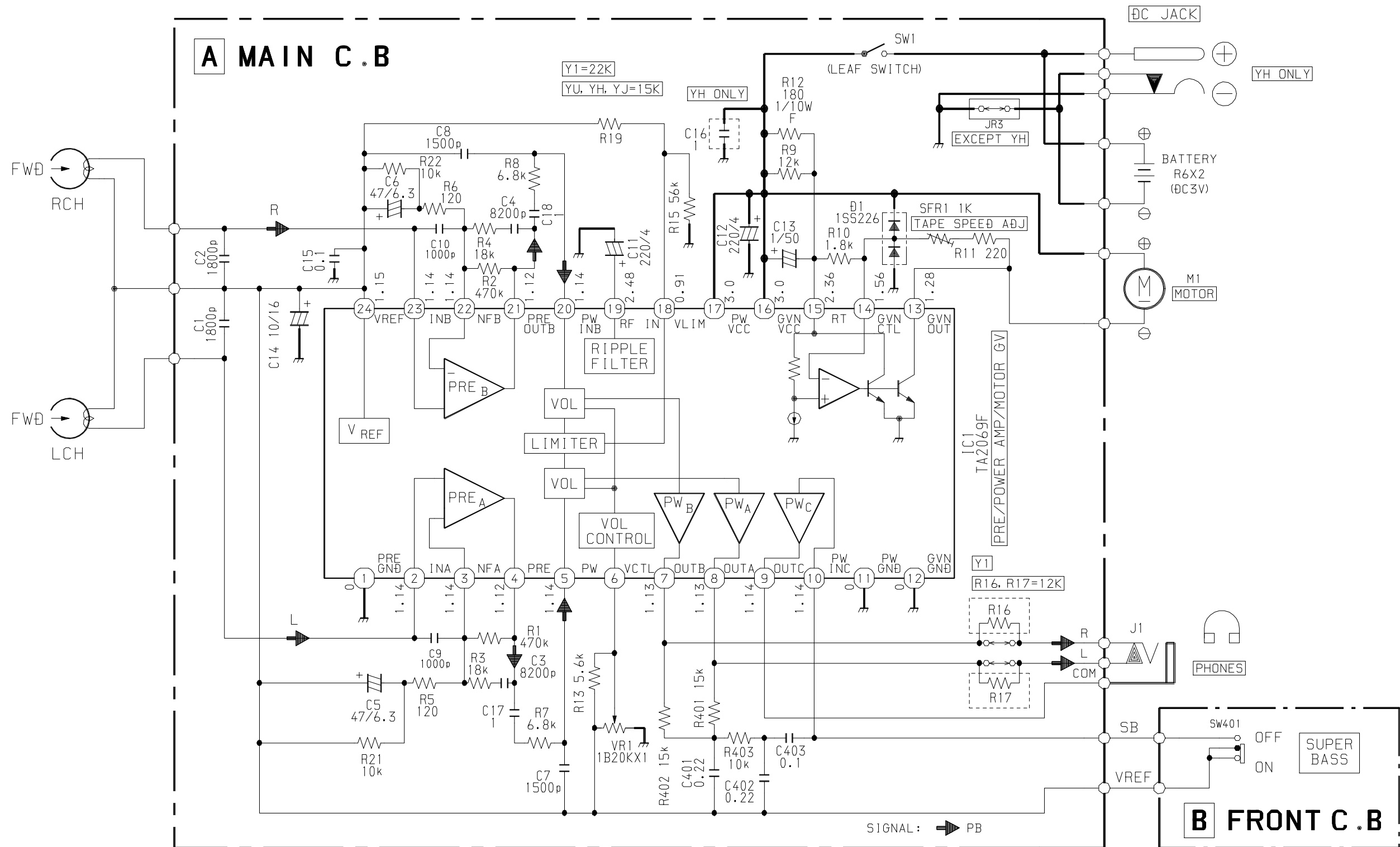

MECHANICAL EXPLODED VIEW



MECHANICAL PARTS LIST

REF. NO.	PART NO.	KANRI NO.	DESCRIPTION
1	8Z-HRL-003-010		KNOB,SL SBASS
2	8Z-HKA-002-010		PANEL,CASS<YU,[L]Y1B,[L]Y1,YH>
2	8Z-HKA-032-010		PANEL,CASS GRE<[G]Y1>
2	8Z-HKA-031-010		PANEL,CASS ORAN<[D]Y1>
2	8Z-HKA-033-010		PANEL,CASS SMK<[G]Y1B>
3	8Z-HKA-001-010		LID,CASS<EXCEPT [G]Y1B>
3	8Z-HKA-008-010		LID,CASS MGRE<[G]Y1B>
4	86-HRM-205-010		SPR-T,CLICK
5	81-HK9-208-210		SPR-P,CASS A
6	87-HRR-206-010		PLATE,HEAD J034<EXCEPT [G]Y1B>
6	88-HKB-204-010		PLATE,HEAD J266G<[G]Y1B>
7	88-HKB-044-010		FRAME,CENTRE GRE<[G]Y1B>
7	88-HKB-043-010		FRAME,CENTRE J034<EXCEPT [G]Y1B>
8	8Z-HKA-201-010		HLDR,JACK
9	8Z-HKA-204-010		SHAFT,CALKING PWB
10	8Z-HKA-202-010		BAT-CONTACT,(+)
11	8Z-HKA-205-010		BAT-CONTACT,(-)
12	8Z-HKA-019-010		LID,BATT J049N<EXCEPT [G]Y1B>
12	8Z-HKA-016-010		LID,BATT MGRE<[G]Y1B>
13	8Z-HKB-035-010		CABI,REAR J049 EGS<EXCEPT YU,[G]Y1B,YH>
13	8Z-HKA-012-010		CABI,REAR MGRE<[G]Y1B>
13	8Z-HKA-006-010		CABI,REAR YH<YH>
13	8Z-HKA-005-010		CABI,REAR YU<YU>
A	87-067-384-010		SCREWVT1.4-3.5HL
B	87-264-525-310		SCREW, V+1.7-2.5
C	87-067-732-010		TAPPING SCREW, VT1.4-3
D	87-067-691-010		SCREW VT+1.7-6

SPRING APPLICATION POSITION

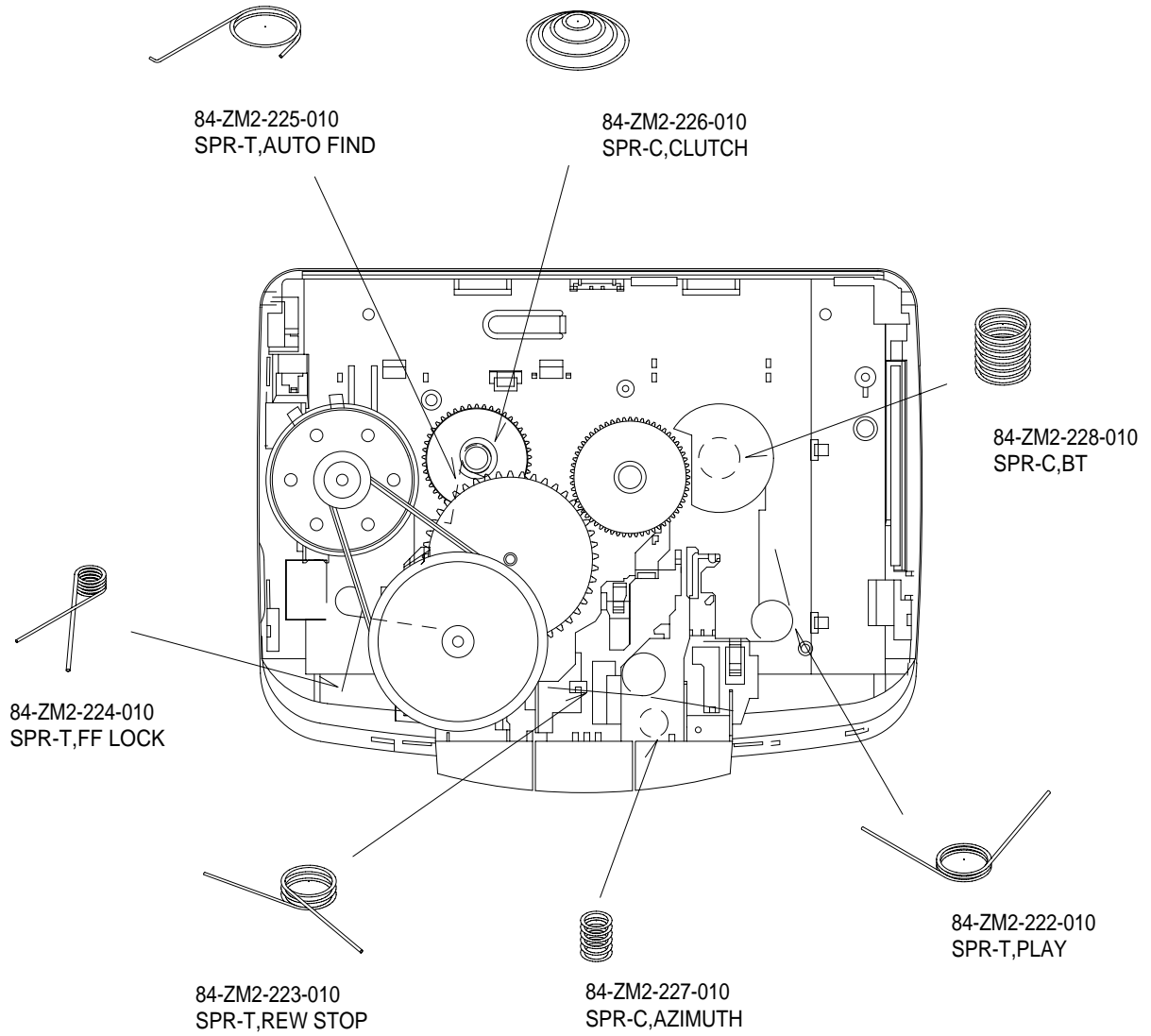

TAPE MECHANISM EXPLODED VIEW

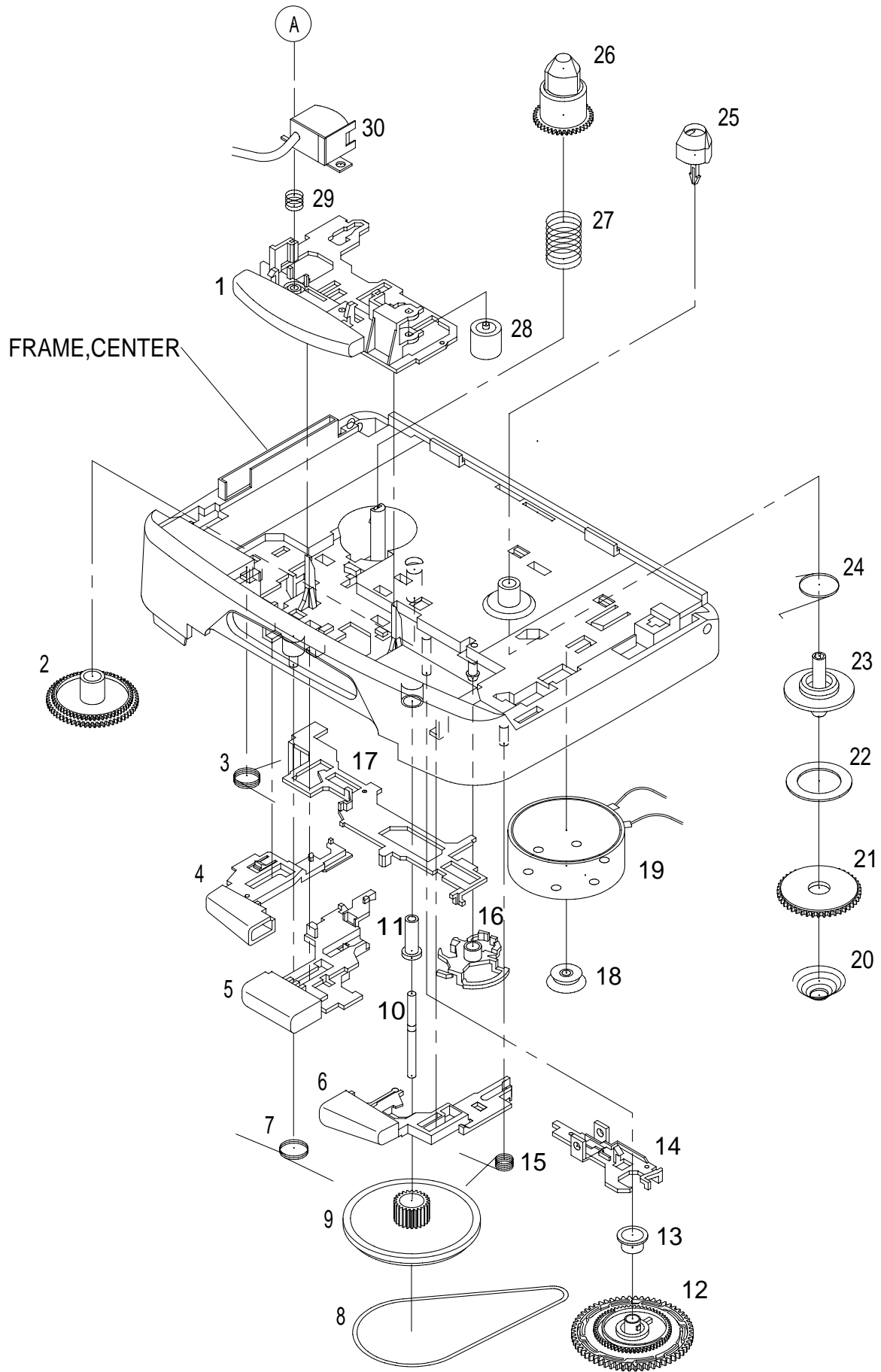

TAPE MECHANISM PARTS LIST

REF. NO.	PART NO.	KANRI NO.	DESCRIPTION
1	84-ZM2-012-010		LEVER,PLAY G
2	84-ZM2-211-01K		GEAR,CONNECT
3	84-ZM2-222-010		SPR-T,PLAY
4	84-ZM2-015-010		LEVER,STOP G
5	84-ZM2-014-010		LEVER,REW G
6	84-ZM2-013-010		LEVER,FF G
7	84-ZM2-223-010		SPR-T,REW STOP
8	84-ZM2-232-010		BELT,MAIN
9	84-ZM2-221-010		FLY-WHL,P2
10	84-ZM2-230-010		CAPSTAN,P 1.8-25
11	84-ZM2-220-01K		BRG,P
12	84-ZM2-210-01K		GEAR,AUTO
13	84-ZM2-218-01K		CAP,GEAR AUTO
14	84-ZM2-208-01K		LEVER,SHIFT
15	84-ZM2-224-010		SPR-T,FF LOCK
16	84-ZM2-207-01K		LEVER,AUTO
17	84-ZM2-206-01K		LEVER,LOCK
18	84-ZM2-219-01K		PULLEY,MOTOR
19	87-045-385-019		MOT (BCY3B11)
20	84-ZM2-226-010		SPR-C,CLUTCH
21	84-ZM2-212-01K		GEAR,CLUTCH
22	84-ZM2-231-019		FELT,CLUTCH
23	84-ZM2-217-01K		SHAFT,REEL
24	84-ZM2-225-010		SPR-T,AUTO FIND
25	84-ZM2-216-01K		REEL TABLE,R
26	84-ZM2-215-01K		REEL TABLE,L
27	84-ZM2-228-010		SPR-C,BT
28	84-ZM2-233-110		PINCH ROL ASSY
29	84-ZM2-227-010		SPR-C,AZIMUTH
30	87-A90-272-010		HEAD,PH MS25P ETH
A	84-ZM2-242-019		S-SCREW,AZIMUTH-2-5.9

ACCESSORIES/PACKAGE LIST

REF. NO.	PART NO.	KANRI NO.	DESCRIPTION
1	8Z-HKA-903-010		IB,YU (ESF)<YU>
1	8Z-HKA-904-010		IB,Y (EGFSI)<Y1>
1	8Z-HKA-905-010		IB,Y (EDPOHCZ)<Y1>
1	8Z-HKA-907-010		IB,YH (ESC)<YH>
2	84-447-019-310		CLIP,BELT
3	87-B30-232-010		HEADPHONE,HP-M029(K)<Y1,YH>
3	87-B30-124-110		HEADPHONE,HP-M028<YU>

L ▶

A4 ▶

サービス技術ニュース	
番号	連絡内容
G-	-
G-	-
G-	-

アイワ株式会社 〒110-8710 東京都台東区池之端1-2-11 ☎03(3827)3111 (代表)
AIWA CO.,LTD. 2-11, IKENOHATA 1-CHOME, TAITO-KU, TOKYO 110, JAPAN TEL:03(3827)3111

9820527 9630472 931261

Printed in Singapore