

# SERVICE MANUAL

DVD SYSTEM

BASIC DVD/CD MECHANISM : DV32BF

SYSTEM	STEREO RECEIVER	DVD PLAYER	SPEAKER SYSTEM	REMOTE CONTROLLER
HT-DV50	AV-HD50	XD-DV50	SX-AVW50 SX-CR677	RC-AAR05 RC-AVL01

- This Service Manual is the "Revision Publishing" and replaces "Simple Manual" AV-HD50 (EZ), (S/M Code No. 09-00C-439-7T1).

# aiwa

S/M Code No. 09-012-439-7R1

REVISION

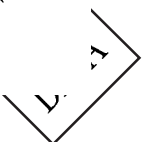

## TABLE OF CONTENTS

SPECIFICATIONS .....	3 ~ 4
PROTECTION OF EYES FROM LASER BEAM DURING SERVICING .....	5
MODEL NO. AV-HD50	
ELECTRICAL MAIN PARTS LIST .....	6 ~ 11
TRANSISTOR ILLUSTRATION .....	12
WIRING – 1 (MAIN) <1 / 2> .....	13
WIRING – 1 (MAIN) <2 / 2> .....	14
SCHEMATIC DIAGRAM – 1 (MAIN) .....	15
WIRING – 2 (FRONT / HP / LED) <1 / 2> .....	16
WIRING – 2 (FRONT / HP / LED) <2 / 2> .....	17
SCHEMATIC DIAGRAM – 2 (FRONT / HP / LED) .....	18
WIRING – 3 (FUNC) <1 / 2> .....	19
WIRING – 3 (FUNC) <2 / 2> .....	20
SCHEMATIC DIAGRAM – 3 (FUNC) .....	21
WIRING – 4 (TUNER) .....	22
SCHEMATIC DIAGRAM – 4 (TUNER) .....	23
IC BLOCK DIAGRAM .....	24 ~ 25
LCD DISPLAY .....	26
IC DESCRIPTION .....	27 ~ 36
ADJUSTMENT .....	37
MECHANICAL EXPLODED VIEW 1 / 1 .....	38
MECHANICAL PARTS LIST 1 / 1 .....	39
MODEL NO. XD-DV50	
ELECTRICAL MAIN PARTS LIST .....	40 ~ 43
TRANSISTOR ILLUSTRATION .....	44
BLOCK DIAGRAM .....	45
WIRING – 1 (MAIN) – Bottom View .....	46
WIRING – 1 (MAIN) – Top View .....	47
SCHEMATIC DIAGRAM – 1 (MAIN : 1 / 9) <POWER SECTION> .....	48
SCHEMATIC DIAGRAM – 2 (MAIN : 2 / 9) <MCU SECTION> .....	49
SCHEMATIC DIAGRAM – 3 (MAIN : 3 / 9) <DVD DSP SECTION> .....	50
SCHEMATIC DIAGRAM – 4 (MAIN : 4 / 9) <RF AMP SECTION> .....	51
SCHEMATIC DIAGRAM – 5 (MAIN : 5 / 9) <SPINDLE DRIVER SECTION> .....	52
SCHEMATIC DIAGRAM – 6 (MAIN : 6 / 9) <SYSCON SECTION> .....	53
SCHEMATIC DIAGRAM – 7 (MAIN : 7 / 9) <AV DECODER SECTION> .....	54
SCHEMATIC DIAGRAM – 8 (MAIN : 8 / 9) <VIDEO ENCODER SECTION> .....	55
SCHEMATIC DIAGRAM – 9 (MAIN : 9 / 9) <VIDEO SECTION> .....	56
WIRING – 2 (FRONT) .....	57
SCHEMATIC DIAGRAM – 10 (FRONT) .....	58
WIRING – 3 (DVD MECHANISM SECTION) .....	59
SCHEMATIC DIAGRAM – 11 (DVD MECHANISM SECTION) .....	60
LCD DISPLAY .....	61
IC BLOCK DIAGRAM .....	62 ~ 65
IC DESCRIPTION .....	66 ~ 81
MECHANICAL EXPLODED VIEW 1 / 1 .....	82
MECHANICAL PARTS LIST 1 / 1 .....	83
GENERAL SPEAKER DISASSEMBLY INSTRUCTIONS (FOR REFERENCE) .....	84
SPEAKER PARTS LIST .....	85
ACCESSORIES / PACKAGE LIST .....	85

# SPECIFICATIONS

## **Stereo Receiver AV-HD50**

### **FM tuner section**

**Tuning range** 87.5 MHz to 108 MHz  
**Usable sensitivity (IHF)** 16.2 dBf  
**Antenna jack** 75 ohms (unbalanced)

### **AM tuner section**

**Tuning range** 530 kHz to 1710 kHz (10 kHz step)  
531 kHz to 1602 kHz (9 kHz step)  
**Usable sensitivity** 700  $\mu$ V/m  
**Antenna** Loop antenna

### **Amplifier section**

#### **Power output (Stereo Mode)**

**Front**  
Rated : 20 W + 20 W (3 ohms,  
T.H.D. 1 %, 1 kHz/DIN 45500)  
Reference : 30 W + 30 W (3 ohms,  
T.H.D. 10 %, 1 kHz/DIN 45324)  
DIN MUSIC POWER : 30 W + 30 W

#### **Power output (Dolby Digital, DTS, or Dolby Pro Logic Mode)**

**Front**  
Rated : 20 W + 20 W (3 ohms,  
T.H.D. 1 %, 1 kHz/DIN 45500)  
Reference : 30 W + 30 W (3 ohms,  
T.H.D. 10 %, 1 kHz/DIN 45324)  
DIN MUSIC POWER : 30 W + 30 W

#### **Rear (Surround)**

Rated : 20 W + 20 W (3 ohms,  
T.H.D. 1 %, 1 kHz/DIN 45500)  
Reference : 30 W + 30 W (3 ohms,  
T.H.D. 10 %, 1 kHz/DIN 45324)  
DIN MUSIC POWER : 30 W + 30 W

#### **Center**

Rated : 20 W (3 ohms, T.H.D. 1 %, 1 kHz/DIN 45500)  
Reference : 30 W (3 ohms, T.H.D. 10 %, 1 kHz/DIN 45324)  
DIN MUSIC POWER : 30 W

#### **Subwoofer**

Rated : 20 W (3 ohms, T.H.D. 1 %, 100 Hz/DIN 45500)  
Reference : 30 W (3 ohms, T.H.D. 10 %, 100 Hz/DIN 45324)  
DIN MUSIC POWER : 30 W

**Total harmonic distortion** 0.2 % (12 W, 1 kHz, 3 ohms, DIN AUDIO, Front)

### **Input/Output**

#### **Input**

#### **AUDIO VIDEO 1 IN, AUDIO VIDEO 2**

**IN** : 360 mV (47 kohms)  
**DIGITAL IN MD, DIGITAL IN DVD** : accept linear PCM signals and Dolby Digital and DTS surround bitstream (32 kHz, 44.1 kHz, 48 kHz, and 96 kHz)

#### **VIDEO VIDEO 1 IN, VIDEO VIDEO 2 IN**

**1 Vp-p** (75 ohms, unbalanced)  
**AUDIO VIDEO 1 OUT** : 320 mV (47 kohms)

#### **DIGITAL OUT**

#### **VIDEO VIDEO 1 OUT, MONITOR OUT**

**1 Vp-p** (75 ohms, unbalanced)  
**FRONT SPEAKERS** : accept speakers of 3 ohms

**SURROUND SPEAKERS** : accept speakers of 3 ohms

**CENTER SPEAKER** : accept speakers of 3 ohms

**SUB WOOFER** terminal : 3 ohms

**SUB WOOFER** jack : 800 mV

**PHONES** (mini jack) : accepts headphones of 32 ohms or more

#### **General**

#### **Power requirements**

230 V AC, 50 Hz

#### **Power consumption**

70 W

#### **Power consumption in standby mode**

ECO OFF : 3.8 W

ECO ON : 3.0 W

#### **Dimensions**

230 (W) x 103 (H) x 233.5 (D) mm

#### **Weight**

2.0 kg

## **DVD Player XD-DV50**

<b>Colour system</b>	<b>DVD</b> : PAL <b>VCD</b> : NTSC/PAL (Switchable)
<b>Supported discs</b>	<b>DVD video discs</b> 12 cm (single-sided single-layer, single-sided double-layer, double-sided-double layer) 8 cm (single-sided single-layer, single-sided double-layer, double-sided-double layer) <b>Compact discs (CD-DA, video CD)</b> 12 cm and 8 cm discs
<b>Video output</b>	Video composite output 1 Vp-p (75 ohms, sync negative) RAC jacks S2 video output Y output : 1 Vp-p (75 ohms, sync negative) C output : 0.286 Vp-p
<b>Audio output</b>	<b>LINE OUT AUDIO R/L</b> 140 mV RMS (1 kHz, -20 dB) RAC jacks (L/R) <b>OPTICAL DIGITAL OUT</b> Fiber optical connector (IEC 958)
<b>Audio output characteristics</b>	Frequency range : CD/VCD : 20 Hz to 20 kHz DVD : 4 Hz to 22 kHz (48 kHz sampling) 4 Hz to 44 kHz (96 kHz sampling) Wow and flutter : unmeasurable
<b>Operating conditions</b>	5 °C to 35 °C (41 °F to 95 °F)
<b>Dimensions</b>	230 x 65 x 180 mm
<b>Weight</b>	950 g
<b>AC adaptor</b>	100-240 V AC, 50/60 Hz DC 10 V, 1.3 A Power consumption 12 W

## **Speaker System SX-AVW50**

<b>Speakers</b>	Front, Surround, Center : full range, 70 mm cone type Subwoofer : 140 mm x 2, bass reflex type
<b>Impedance</b>	3 ohms
<b>Maximum input power</b>	30 W (peak)
<b>Dimensions (W x H x D)</b>	Front : 90 x 167 x 76 mm Surround : 90 x 167 x 76 mm Center : 235 x 90 x 76 mm Subwoofer : 181 x 406 x 265 mm
<b>Weight</b>	Front : 0.45 kg Surround : 0.4 kg Center : 0.5 kg Subwoofer : 4.5 kg
	<ul style="list-style-type: none"><li>• Design and specifications are subject to change without notice.</li><li>• Manufactured under license from Dolby Laboratories Licensing Corporation. "DOLBY", the double-D symbol  and "PRO LOGIC" are trademarks of Dolby Laboratories Licensing Corporation.</li><li>• Manufactured under license from Digital Theater System, Inc. US Pat. No. 5,451,942 and other worldwide patents issued and pending. "DTS" and "DTS Digital Surround" are trademarks of Digital Theater System Inc. ©1996 Digital Theater system, Inc. All rights reserved.</li></ul>

## PROTECTION OF EYES FROM LASER BEAM DURING SERVICING

This set employs laser. Therefore, be sure to follow carefully the instructions below when servicing.

### WARNING!

WHEN SERVICING, DO NOT APPROACH THE LASER EXIT WITH THE EYE TOO CLOSELY. IN CASE IT IS NECESSARY TO CONFIRM LASER BEAM EMISSION. BE SURE TO OBSERVE FROM A DISTANCE OF MORE THAN 30cm FROM THE SURFACE OF THE OBJECTIVE LENS ON THE OPTICAL PICK-UP BLOCK.



- Caution: Invisible laser radiation when open and interlocks defeated avoid exposure to beam.
- Advarsel: Usynlig laserstråling ved åbning, når sikkerhedsafbrydere er ude af funktion. Undgå udsættelse for stråling.

### VAROITUS!

Laiteen Käyttäminen muulla kuin tässä käyttöohjeessa mainitulla tavalla saattaa altistaa käyt-täjän turvallisuusluokan 1 ylittävälle näkymättömälle lasersäteilylle.

### WARNING!

Om apparaten används på annat sätt än vad som specificeras i denna bruksanvisning, kan användaren utsättas för osynlig laserstrålning, som överskrider gränsen för laserklass 1.

### Precaution to replace Optical block

Body or clothes electrostatic potential could ruin laser diode in the optical block. Be sure ground body and workbench, and use care the clothes do not touch the diode.

- 1) After the connection, remove solder shown in the right figure.

### CAUTION

Use of controls or adjustments or performance of procedures other than those specified herein may result in hazardous radiation exposure.

### ATTENTION

L'utilisation de commandes, réglages ou procédures autres que ceux spécifiés peut entraîner une dangereuse exposition aux radiations.

### ADVARSEL!

Usynlig laserstråling ved åbning, når sikkerhedsafbrydere er ude af funktion. Undgå udsættelse for stråling.

This Compact Disc player is classified as a CLASS 1 LASER product.

The CLASS 1 LASER PRODUCT label is located on the rear exterior.

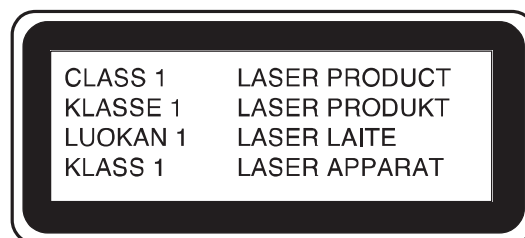

### (SF-HD3AV/HD3AVC)

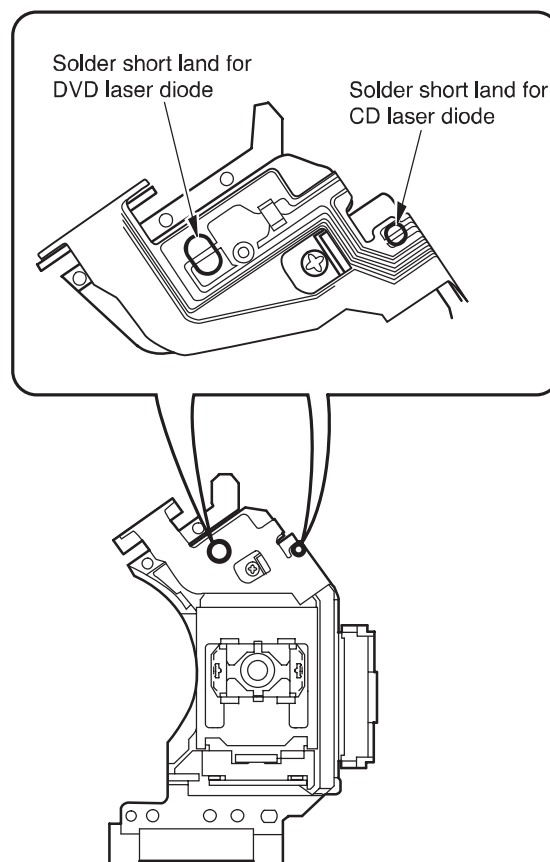

MODEL NO.

# AV-HD50

## ELECTRICAL MAIN PARTS LIST

REF. NO.	PART NO.	KANRI NO.	DESCRIPTION	REF. NO.	PART NO.	KANRI NO.	DESCRIPTION
<b>IC</b>							
	87-A21-918-040		C-IC,NJM4558V	87-A40-574-080			ZENER,MTZJ3.0A
	87-A21-862-010		IC,STR-F6676	87-A40-269-080			C-DIODE,MC2836
	87-A21-819-010		IC,SE013E	87-A40-270-080			C-DIODE,MC2838
	87-020-970-010		IC,NJM79L09	87-017-931-080			ZENER,MTZJ5.6B
	87-A20-389-010		IC,NJM7809FA	87-A40-002-080			ZENER,MTZJ5.1C
	87-A21-825-040		C-IC,M61501FP	87-A40-956-080			DIODE,EK04
	8A-AR6-601-010		C-IC,UPD780308-033	87-A40-553-080			DIODE,1N4003 LES
	87-020-730-080		IC,TC4069UBF	87-070-274-080			DIODE,1N4003 SEM
	87-A21-831-010		IC,SPS-422-1-F1	87-017-932-080			ZENER,MTZJ6.2B
	87-002-943-080		IC,TC4011BF	87-A40-344-080			ZENER,MTZJ6.2C
	87-020-903-010		IC,NJM7805FA	87-A40-345-080			ZENER,MTZJ10C
	87-A21-824-010		IC,TA2020-020	87-A40-348-080			ZENER,MTZJ3.3A
	87-A20-736-010		IC,BA033ST	87-070-136-080			ZENER,MTZJ5.1B
	87-A21-760-040		C-IC,NJM4580V	87-017-149-080			ZENER,HZS6A2L
	87-A21-503-010		C-IC,AK4527VQ	<b>MAIN C.B</b>			
	87-A21-823-040		C-IC,NJM4556AM	△ C2	87-A11-353-010		CAP,M/P 0.22-275 M ECQUL
	87-A21-504-010		IC,GP1F37R1	△ C3	87-A11-352-010		CAP,M/P 0.1-275 M ECQUL
	87-A21-967-010		IC,GP1FA551TZ	△ C4	87-A10-413-010		CAP,CER 2200P-4K M E KX
	87-A21-826-040		C-IC,AK4112A	△ C5	87-A10-413-010		CAP,CER 2200P-4K M E KX
	87-A21-500-010		C-IC,YSS912	△ C6	87-A10-922-090		CAP,CER 0.01-250 M F KH
	87-020-784-040		C-IC,TC4053BF	C7	87-A10-646-090		CAP,E 220-400 SMH (25.4*40)
	87-070-205-010		IC,TC9299P	C8	87-A12-447-010		CAP,M/P 0.01-1000 J
	87-A21-419-040		C-IC,NJM14558MD-TE2	C9	87-A12-095-080		CAP,E 100-50 SMG
	87-A20-820-010		IC,BA7625	C10	87-A11-104-080		CAP,TC U 470P-50 J CH
	87-A20-440-040		C-IC,BU1920FS	C11	87-A11-104-080		CAP,TC U 470P-50 J CH
	87-A21-695-010		IC,LA1845L	C12	87-A10-833-080		CAP,CER 1000P-2K K R
	87-A21-928-010		IC,LC72131D-N	△ C13	87-A10-519-010		CAP,CER 4700P-4K M E KX
				△ C14	87-A11-148-080		CAP,TC U 0.1-50 Z F
				△ C15	87-A10-922-090		CAP,CER 0.01-250 M F KH
				△ C16	87-A10-519-010		CAP,CER 4700P-4K M E KX
<b>TRANSISTOR</b>							
	87-A30-075-080		C-TR,2SA1235F	△ C17	87-A10-519-010		CAP,CER 4700P-4K M E KX
	87-026-610-080		TR,KTC3198GR	△ C18	87-A10-519-010		CAP,CER 4700P-4K M E KX
	87-A30-107-070		C-TR,CMBT5401	△ C19	87-A10-519-010		CAP,CER 4700P-4K M E KX
	87-A30-076-080		C-TR,2SC3052F	C20	87-010-196-080		CHIP CAPACITOR,0.1-25
	87-A30-071-080		C-TR,RT1N 144C	C21	87-A12-070-080		CAP,E 33-25 SMG
	89-213-702-010		TR,2SB1370E	C51	87-014-081-080		CAP,PP 0.01-100 J
	87-A30-074-080		C-TR,RT1P 141C	C52	87-A10-730-080		CAP,E 1000-16 SMG
	87-A30-083-080		TR,CSD1489B	C53	87-A10-831-010		CAP,E 1000-25 M SMG
	89-110-155-080		TR,2SA1015GR	C54	87-014-081-080		CAP,PP 0.01-100 J
	89-318-155-080		TR,2SC1815GR	C55	87-010-928-000		CAP,E 4700-25 M SMG
	87-A30-117-010		TR,2SA1357 Y	C56	87-010-197-080		CAP, CHIP 0.01 DM
	89-320-011-080		TR,2SC2001K	C57	87-010-196-080		CHIP CAPACITOR,0.1-25
	87-A30-087-080		C-FET,2SK2158	C58	87-010-186-080		CAP,CHIP 4700P
	87-A30-164-080		TR,CSC2001K	C59	87-016-083-080		C-CAP,S 0.15-16 RK
	87-A30-086-040		C-TR,CSD1306E	C60	87-012-393-080		C-CAP,S 0.22-16 R K
	87-026-608-080		C-TR,DTC123JK	C61	87-A10-831-010		CAP,E 1000-25 M SMG
	87-026-609-080		TR,KTA1266GR	C64	87-A10-918-080		CAP,E 100-16 SMG
	89-503-602-080		C-FET,2SK360E	C65	87-A12-067-080		CAP,E 330-16 SMG
	89-327-143-080		C-TR,2SC27140	C81	87-A12-091-080		CAP,E 10-50 SMG
	87-A30-234-080		TR,CSC4115BC	C82	87-A12-073-080		CAP,E 220-25 SMG
	87-A30-489-080		C-TR,KRA107S	C83	87-A12-091-080		CAP,E 10-50 SMG
				C84	87-A12-679-080		CAP,E 47-16 M OS
				C85	87-010-178-080		CHIP CAP 1000P
				C86	87-010-198-080		CAP, CHIP 0.022
				C87	87-016-521-010		CAP,E2200-16 SMG
<b>DIODE</b>							
	87-020-465-080		DIODE,1SS133	C101	87-010-196-080		CHIP CAPACITOR,0.1-25
	87-A41-021-010		DIODE,REV-606	C102	87-010-196-080		CHIP CAPACITOR,0.1-25
	87-A40-955-080		DIODE,SARS01	C103	87-010-196-080		CHIP CAPACITOR,0.1-25
	87-A40-951-080		DIODE,AG01Z	C104	87-010-196-080		CHIP CAPACITOR,0.1-25
	87-A40-960-080		ZENER,MTZJ36B	C105	87-010-196-080		CHIP CAPACITOR,0.1-25
	87-A40-458-080		ZENER,MTZJ18B	C106	87-010-196-080		CHIP CAPACITOR,0.1-25
	87-A40-509-080		ZENER,MTZJ6.8C	C107	87-010-805-080		CAP, S 1-16
	87-A40-950-010		DIODE,FMB-26L	C108	87-010-805-080		CAP, S 1-16
	87-A40-953-080		DIODE,EK09				

REF. NO.	PART NO.	KANRI NO.	DESCRIPTION	REF. NO.	PART NO.	KANRI NO.	DESCRIPTION
C109	87-010-805-080		CAP, S 1-16	C438	87-016-369-080		C-CAP,S 0.033-25 B K
C110	87-010-805-080		CAP, S 1-16	C439	87-016-369-080		C-CAP,S 0.033-25 B K
C111	87-010-805-080		CAP, S 1-16	C440	87-016-369-080		C-CAP,S 0.033-25 B K
C112	87-010-805-080		CAP, S 1-16	△ CN1	87-099-674-010		CONN,2P V VA
C113	87-A10-918-080		CAP,E 100-16 SMG	CN51	87-A60-624-010		CONN,7P V 2MM JMT
C114	87-A10-918-080		CAP,E 100-16 SMG	CN52	87-A60-620-010		CONN,3P V 2MM JMT
C115	87-A10-918-080		CAP,E 100-16 SMG	CN551	87-A60-056-010		CONN,12P V 9604S-12C
C201	87-A12-088-080		CAP,E 2.2-50 SMG	CN552	87-A60-059-010		CONN,08P V 9604S-08C
C202	87-A12-088-080		CAP,E 2.2-50 SMG	△ F1	87-035-237-010		FUSE,2A 250V F217
C203	87-012-368-080		C-CAP,S 0.1-50 F	FB51	87-008-372-080		FILTER, EMI BL01 RN1
C204	87-012-368-080		C-CAP,S 0.1-50 F	FB52	87-008-372-080		FILTER, EMI BL01 RN1
C205	87-A10-507-080		CAP,E 220-10 M 105 KME	FB53	87-008-372-080		FILTER, EMI BL01 RN1
C206	87-A12-087-080		CAP,E 1-50 SMG	FB54	87-008-474-080		F-BEAD,EMI BL02RN1-R62T2 EMI
C207	87-012-368-080		C-CAP,S 0.1-50 F	△ FC1	87-A90-160-080		FUSE CLAMP,FC 51F
C211	87-016-141-080		CAP,E 1-50 KME	△ FC2	87-A90-160-080		FUSE CLAMP,FC 51F
C212	87-012-368-080		C-CAP,S 0.1-50 F	FC551	88-912-091-110		FF-CABLE,12P 1.25 90MM
C216	87-010-050-010		CAP,E 470-25	FC552	88-908-121-110		FF-CABLE,8P 1.25 120MM
C217	87-012-368-080		C-CAP,S 0.1-50 F	J51	87-A61-504-010		JACK,DC 5.15 BLK 10.5
C229	87-A10-201-080		C-CAP,S0.33-16 KB	J201	87-A61-548-010		TERMINAL, 4P LQR0410-0117
C230	87-A10-201-080		C-CAP,S0.33-16 KB	J301	87-A61-547-010		TERMINAL, 8P LQR0810-0311
C231	87-A12-769-080		CAP,E 1000-25 M 105 KMG	△ JW203	87-A90-195-080		PROTECTOR 7A 491SERIES 60V
C233	87-010-154-080		CAP CHIP 10P-50	△ JW303	87-A90-195-080		PROTECTOR 7A 491SERIES 60V
C234	87-010-154-080		CAP CHIP 10P-50 D	△ JW403	87-A90-195-080		PROTECTOR 7A 491SERIES 60V
C235	87-010-322-080		C-CAP,S 100P-50 CH	△ L1	87-A92-140-010		FLTR,LINE HF2836-253
C236	87-010-322-080		C-CAP,S 100P-50 CH	L81	87-A50-693-010		COIL,39UH-RCR-110D
C237	87-016-369-080		C-CAP,S 0.033-25 B K	L201	87-A50-696-010		COIL,10UH 7310
C238	87-016-369-080		C-CAP,S 0.033-25 B K	L202	87-A50-696-010		COIL,10UH 7310
C239	87-016-369-080		C-CAP,S 0.033-25 B K	L203	87-A50-696-010		COIL,10UH 7310
C240	87-016-369-080		C-CAP,S 0.033-25 B K	L204	87-A50-696-010		COIL,10UH 7310
C301	87-A12-088-080		CAP,E 2.2-50 SMG	L301	87-A50-696-010		COIL,10UH 7310
C302	87-A12-088-080		CAP,E 2.2-50 SMG	L302	87-A50-696-010		COIL,10UH 7310
C303	87-012-368-080		C-CAP,S 0.1-50 F	L303	87-A50-696-010		COIL,10UH 7310
C304	87-012-368-080		C-CAP,S 0.1-50 F	L304	87-A50-696-010		COIL,10UH 7310
C305	87-A10-507-080		CAP,E 220-10 M 105 KME	L401	87-A50-696-010		COIL,10UH 7310
C306	87-A12-087-080		CAP,E 1-50 SMG	L402	87-A50-696-010		COIL,10UH 7310
C307	87-012-368-080		C-CAP,S 0.1-50 F	L403	87-A50-696-010		COIL,10UH 7310
C311	87-016-141-080		CAP,E 1-50 KME	L404	87-A50-696-010		COIL,10UH 7310
C312	87-012-368-080		C-CAP,S 0.1-50 F	△ PR51	87-A90-091-080		PROTECTOR,2A 491SERIES 60V
C316	87-010-050-010		CAP,E 470-25	△ PS1	87-A91-407-010		P-COUPPLER,ON3171-R
C317	87-012-368-080		C-CAP,S 0.1-50 F	△ PT1	8A-AR6-608-010		PT,SW AAR-6EZ
C329	87-A10-201-080		C-CAP,S0.33-16 KB	R2	87-A00-244-090		RES,M/F 68K-2W J RSF(S)
C330	87-A10-201-080		C-CAP,S0.33-16 KB	R4	87-A00-161-090		RES,M/F 47-2W J RSF(S)
C331	87-A12-769-080		CAP,E 1000-25 M 105 KMG	R5	87-025-332-090		RES,NF 10-1/4W
C333	87-010-154-080		CAP CHIP 10P-50 D	R10	87-A00-283-090		RES,M/F 0.27-2W J RSF(S)
C334	87-010-154-080		CAP CHIP 10P-50 D	R11	87-A00-283-090		RES,M/F 0.27-2W J RSF(S)
C335	87-010-322-080		C-CAP,S 100P-50 CH	R81	87-A00-258-080		RES,M/F 0.22-1W J
C336	87-010-322-080		C-CAP,S 100P-50 CH	R95	87-A00-260-080		RES,M/F 0.47-1W J
C337	87-016-369-080		C-CAP,S 0.033-25 B K	RY201	87-045-389-010		RELAY,12V OSA-SS-212DM5
C338	87-016-369-080		C-CAP,S 0.033-25 B K	RY301	87-045-389-010		RELAY,12V OSA-SS-212DM5
C339	87-016-369-080		C-CAP,S 0.033-25 B K	RY401	87-045-389-010		RELAY,12V OSA-SS-212DM5
C340	87-016-369-080		C-CAP,S 0.033-25 B K	TH1	87-A91-978-010		THMS,NTH11D5R0
C401	87-A12-088-080		CAP,E 2.2-50 SMG				
C402	87-A12-088-080		CAP,E 2.2-50 SMG				
C403	87-012-368-080		C-CAP,S 0.1-50 F				
C404	87-012-368-080		C-CAP,S 0.1-50 F	FRONT C.B			
C405	87-A10-507-080		CAP,E 220-10 M 105 KME	C101	87-010-322-080		C-CAP,S 100P-50 CH
C406	87-A12-087-080		CAP,E 1-50 SMG	C102	87-010-322-080		C-CAP,S 100P-50 CH
C407	87-012-368-080		C-CAP,S 0.1-50 F	C103	87-010-322-080		C-CAP,S 100P-50 CH
C411	87-016-141-080		CAP,E 1-50 KME	C104	87-010-322-080		C-CAP,S 100P-50 CH
C412	87-012-368-080		C-CAP,S 0.1-50 F	C105	87-010-312-080		C-CAP,S 15P-50 CH
C416	87-010-050-010		CAP,E 470-25	C106	87-012-140-080		CAP 470P
C417	87-012-368-080		C-CAP,S 0.1-50 F	C107	87-012-155-080		C-CAP 180P-50CH
C429	87-A10-201-080		C-CAP,S0.33-16 KB	C108	87-010-322-080		C-CAP,S 100P-50 CH
C430	87-A10-201-080		C-CAP,S0.33-16 KB	C109	87-A10-819-040		CAP,E 47-25 5L SRM
C431	87-A12-769-080		CAP,E 1000-25 M 105 KMG	C110	87-010-196-080		CHIP CAPACITOR,0.1-25
C433	87-010-154-080		CAP CHIP 10P-50 D	C111	87-010-322-080		C-CAP,S 100P-50 CH
C434	87-010-154-080		CAP CHIP 10P-50 D	C112	87-010-322-080		C-CAP,S 100P-50 CH
C435	87-010-322-080		C-CAP,S 100P-50 CH	C113	87-010-322-080		C-CAP,S 100P-50 CH
C436	87-010-322-080		C-CAP,S 100P-50 CH	C114	87-010-322-080		C-CAP,S 100P-50 CH
C437	87-016-369-080		C-CAP,S 0.033-25 B K	C115	87-010-322-080		C-CAP,S 100P-50 CH





REF. NO.	PART NO.	KANRI NO.	DESCRIPTION	REF. NO.	PART NO.	KANRI NO.	DESCRIPTION
C318	87-010-196-080		CHIP CAPACITOR,0.1-25	C625	87-012-154-080		C-CAP,S 150P-50 CH
C319	87-010-248-080		CAP, ELECT 220-10V	C626	87-012-154-080		C-CAP,S 150P-50 CH
C320	87-010-196-080		CHIP CAPACITOR,0.1-25	C627	87-010-196-080		CHIP CAPACITOR,0.1-25
C321	87-A12-091-080		CAP,E 10-50 SMG	C628	87-010-196-080		CHIP CAPACITOR,0.1-25
C322	87-010-196-080		CHIP CAPACITOR,0.1-25	C641	87-A12-091-080		CAP,E 10-50 SMG
C324	87-010-322-080		C-CAP,S 100P-50 CH	C642	87-A12-091-080		CAP,E 10-50 SMG
C325	87-010-322-080		C-CAP,S 100P-50 CH	C643	87-010-178-080		CHIP CAP 1000P
C326	87-012-140-080		CAP 470P	C644	87-010-178-080		CHIP CAP 1000P
C335	87-010-196-080		CHIP CAPACITOR,0.1-25	C645	87-012-154-080		C-CAP,S 150P-50 CH
C336	87-A11-132-080		CAP,TC U 0.01-50 K B	C646	87-012-154-080		C-CAP,S 150P-50 CH
C401	87-010-182-080		C-CAP,S 2200P-50 B	C647	87-010-196-080		CHIP CAPACITOR,0.1-25
C402	87-010-182-080		C-CAP,S 2200P-50 B	C648	87-010-196-080		CHIP CAPACITOR,0.1-25
C403	87-010-182-080		C-CAP,S 2200P-50 B	C661	87-A12-091-080		CAP,E 10-50 SMG
C404	87-010-322-080		C-CAP,S 100P-50 CH	C662	87-A12-091-080		CAP,E 10-50 SMG
C405	87-010-322-080		C-CAP,S 100P-50 CH	C663	87-016-669-080		C-CAP,S 0.1-25 K B
C406	87-010-263-080		CAP, ELECT 100-10V	C664	87-016-669-080		C-CAP,S 0.1-25 K B
C407	87-010-196-080		CHIP CAPACITOR,0.1-25	C665	87-A12-091-080		CAP,E 10-50 SMG
C408	87-010-263-080		CAP, ELECT 100-10V	C666	87-A12-091-080		CAP,E 10-50 SMG
C409	87-010-196-080		CHIP CAPACITOR,0.1-25	C667	87-A12-091-080		CAP,E 10-50 SMG
C412	87-010-263-080		CAP, ELECT 100-10V	C668	87-016-083-080		C-CAP,S 0.15-16 RK
C413	87-010-196-080		CHIP CAPACITOR,0.1-25	C669	87-010-196-080		CHIP CAPACITOR,0.1-25
C417	87-010-322-080		C-CAP,S 100P-50 CH	C670	87-010-196-080		CHIP CAPACITOR,0.1-25
C418	87-010-322-080		C-CAP,S 100P-50 CH	C701	87-010-154-080		CAP CHIP 10P
C419	87-010-322-080		C-CAP,S 100P-50 CH	C702	87-010-154-080		CAP CHIP 10P
C423	87-010-178-080		CHIP CAP 1000P	C703	87-A12-091-080		CAP,E 10-50 SMG
C424	87-010-322-080		C-CAP,S 100P-50 CH	C704	87-A12-091-080		CAP,E 10-50 SMG
C501	87-010-401-080		CAP, ELECT 1-50V	C705	87-010-196-080		CHIP CAPACITOR,0.1-25
C502	87-010-401-080		CAP, ELECT 1-50V	C706	87-010-196-080		CHIP CAPACITOR,0.1-25
C503	87-010-401-080		CAP, ELECT 1-50V	C707	87-A12-091-080		CAP,E 10-50 SMG
C504	87-010-401-080		CAP, ELECT 1-50V	C708	87-A12-091-080		CAP,E 10-50 SMG
C505	87-010-374-080		CAP, ELECT 47-10V	C721	87-016-083-080		C-CAP,S 0.15-16 RK
C506	87-010-197-080		CAP, CHIP 0.01 DM	C722	87-016-083-080		C-CAP,S 0.15-16 RK
C507	87-010-263-080		CAP, ELECT 100-10V	C723	87-010-154-080		CAP CHIP 10P
C508	87-010-196-080		CHIP CAPACITOR,0.1-25	C724	87-010-154-080		CAP CHIP 10P
C509	87-010-196-080		CHIP CAPACITOR,0.1-25	C725	87-A12-091-080		CAP,E 10-50 SMG
C510	87-010-197-080		CAP, CHIP 0.01 DM	C726	87-A12-091-080		CAP,E 10-50 SMG
C511	87-012-140-080		CAP 470P	C727	87-010-196-080		CHIP CAPACITOR,0.1-25
C512	87-010-196-080		CHIP CAPACITOR,0.1-25	C728	87-010-196-080		CHIP CAPACITOR,0.1-25
C513	87-010-322-080		C-CAP,S 100P-50 CH	C741	87-010-154-080		CAP CHIP 10P
C514	87-010-196-080		CHIP CAPACITOR,0.1-25	C742	87-010-154-080		CAP CHIP 10P
C515	87-010-374-080		CAP, ELECT 47-10V	C743	87-A12-091-080		CAP,E 10-50 SMG
C520	87-010-196-080		CHIP CAPACITOR,0.1-25	C744	87-A12-091-080		CAP,E 10-50 SMG
C521	87-010-401-080		CAP, ELECT 1-50V	C745	87-010-196-080		CHIP CAPACITOR,0.1-25
C522	87-010-196-080		CHIP CAPACITOR,0.1-25	C746	87-010-196-080		CHIP CAPACITOR,0.1-25
C523	87-010-314-080		C-CAP,S 22P-50V	C751	87-010-196-080		CHIP CAPACITOR,0.1-25
C526	87-010-314-080		C-CAP,S 22P-50V	C752	87-012-358-080		C-CAP,S 0.47-10 F Z
C527	87-010-314-080		C-CAP,S 22P-50V	C753	87-010-196-080		CHIP CAPACITOR,0.1-25
C528	87-010-404-080		CAP, ELECT 4.7-50V	C754	87-A10-793-080		C-CAP,S 0.12-16 K B
C529	87-010-196-080		CHIP CAPACITOR,0.1-25	C755	87-A10-793-080		C-CAP,S 0.12-16 K B
C530	87-010-196-080		CHIP CAPACITOR,0.1-25	C756	87-010-597-080		C-CAP,S 0.056-16V,RK
C531	87-010-196-080		CHIP CAPACITOR,0.1-25	C761	87-A12-091-080		CAP,E 10-50 SMG
C532	87-010-197-080		CAP, CHIP 0.01 DM	C762	87-010-196-080		CHIP CAPACITOR,0.1-25
C541	87-010-311-080		CAP 12P	C763	87-A12-091-080		CAP,E 10-50 SMG
C542	87-010-313-080		CAP, CHIP 18P	C764	87-010-196-080		CHIP CAPACITOR,0.1-25
C601	87-A12-091-080		CAP,E 10-50 SMG	C781	87-010-314-080		C-CAP,S 22P-50V
C602	87-A12-091-080		CAP,E 10-50 SMG	C782	87-010-314-080		C-CAP,S 22P-50V
C603	87-010-178-080		CHIP CAP 1000P	C783	87-010-196-080		CHIP CAPACITOR,0.1-25
C604	87-010-178-080		CHIP CAP 1000P	C784	87-010-196-080		CHIP CAPACITOR,0.1-25
C605	87-012-154-080		C-CAP,S 150P-50 CH	C785	87-A12-091-080		CAP,E 10-50 SMG
C606	87-012-154-080		C-CAP,S 150P-50 CH	C786	87-010-196-080		CHIP CAPACITOR,0.1-25
C607	87-010-196-080		CHIP CAPACITOR,0.1-25	C787	87-A12-091-080		CAP,E 10-50 SMG
C608	87-010-196-080		CHIP CAPACITOR,0.1-25	C801	87-A12-091-080		CAP,E 10-50 SMG
C610	87-A12-091-080		CAP,E 10-50 SMG	C802	87-010-196-080		CHIP CAPACITOR,0.1-25
C611	87-A12-091-080		CAP,E 10-50 SMG	C803	87-A12-091-080		CAP,E 10-50 SMG
C612	87-010-322-080		C-CAP,S 100P-50 CH	C804	87-010-196-080		CHIP CAPACITOR,0.1-25
C613	87-010-322-080		C-CAP,S 100P-50 CH	C821	87-010-404-080		CAP, ELECT 4.7-50V
C621	87-A12-091-080		CAP,E 10-50 SMG	C822	87-010-401-080		CAP, ELECT 1-50V
C622	87-A12-091-080		CAP,E 10-50 SMG	C823	87-010-196-080		CHIP CAPACITOR,0.1-25
C623	87-010-178-080		CHIP CAP 1000P	C824	87-010-196-080		CHIP CAPACITOR,0.1-25
C624	87-010-178-080		CHIP CAP 1000P	C901	87-010-382-080		CAP, ELECT 22-25V

REF. NO.	PART NO.	KANRI NO.	DESCRIPTION	REF. NO.	PART NO.	KANRI NO.	DESCRIPTION
C902	87-010-382-080		CAP, ELECT 22-25V	C790	87-016-034-080		CHIP CAP U 0.027-25F
C906	87-010-322-080		C-CAP,S 100P-50 CH	C791	87-010-831-080		C-CAP,U,0.1-16F
C907	87-010-196-080		CHIP CAPACITOR,0.1-25	C792	87-012-286-080		C-CAP,U 0.01-25 K B
C908	87-010-374-080		CAP, ELECT 47-10V	C793	87-A11-056-080		C-CAP,U 1-10 Z F
C909	87-010-371-080		CAP, ELECT 470-6.3V	C795	87-012-286-080		C-CAP,U 0.01-25 K B
C910	87-010-371-080		CAP, ELECT 470-6.3V	C798	87-012-286-080		C-CAP,U 0.01-25 K B
C911	87-010-371-080		CAP, ELECT 470-6.3V	C799	87-010-982-040		CAP,E 33-25 GAS
C951	87-010-178-080		CHIP CAP 1000P-50 K B	C800	87-010-829-080		CAP, U 0.047-16
C952	87-010-314-080		C-CAP,S 22P-50V	C801	87-A11-056-080		C-CAP,U 1-10 Z F
C953	87-010-316-080		C-CAP,S 33P-50 CH	C802	87-010-829-080		CAP, U 0.047-16
C954	87-010-197-080		CAP, CHIP 0.01 DM	C804	87-010-555-040		CAP,E 100-10 GAS
C955	87-010-197-080		CAP, CHIP 0.01 DM	C807	87-A10-463-080		C-CAP,U,0.47-10 Z F
C956	87-A12-091-080		CAP,E 10-50 SMG	C808	87-A11-056-080		C-CAP,U 1-10 Z F
C957	87-010-196-080		CHIP CAPACITOR,0.1-25	C809	87-A11-056-080		C-CAP,U 1-10 Z F
C958	87-A12-091-080		CAP,E 10-50 SMG	C810	87-010-831-080		C-CAP,U,0.1-16F
C959	87-012-140-080		CAP 470P-50	C814	87-012-286-080		C-CAP,U 0.01-25 K B
C960	87-012-156-080		C-CAP,S 220P-50 CH	C815	87-A10-463-080		C-CAP,U,0.47-10 Z F
C961	87-012-156-080		C-CAP,S 220P-50 CH	C816	87-A10-463-080		C-CAP,U,0.47-10 Z F
CN1	87-A60-619-010		CONN,2P V 2MM JMT	C821	87-A11-063-080		C-CAP,S 4.7-10 Z F
CN101	87-A60-079-010		CONN,08P H 9604S-08F	C823	87-012-274-080		CHIP CAP,U 1000P-50B
CN103	87-099-751-010		CONN,16P V 9604SC	C824	87-A11-063-080		C-CAP,S 4.7-10 Z F
CN104	87-A60-071-010		CONN,25P H 9604S-25F	C825	87-010-829-080		C-CAP,U 0.047-16 Z F
CNA102	8A-AR6-641-010		CONN ASSY,7P -POWER	C831	87-010-552-040		CAP,E 22-16 GAS
FB101	87-008-372-080		FILTER, EMI BL01 RN1	C837	87-012-286-080		CAP, U 0.01-25
FB103	87-008-372-080		FILTER, EMI BL OIRNI	C842	87-012-286-080		C-CAP,U 0.01-25 K B
FB104	87-008-372-080		FILTER, EMI BL OIRNI	C844	87-012-286-080		C-CAP,U 0.01-25 K B
FB201	87-008-372-080		FILTER, EMI BL OIRNI	C847	87-012-286-080		C-CAP,U 0.01-25 K B
FB301	87-008-372-010		FILTER, EMI BL01 RN1	C848	87-012-286-080		C-CAP,U 0.01-25 K B
FB302	87-008-372-080		FILTER, EMI BL01 RN1	C850	87-A11-056-080		C-CAP,U 1-10 Z F
FB401	87-008-372-080		FILTER, EMI BL01 RN1	C851	87-012-286-080		C-CAP,U 0.01-25 K B
FB402	87-008-372-080		FILTER, EMI BL01 RN1	C852	87-012-286-080		C-CAP,U 0.01-25 K B
FB403	87-008-372-080		FILTER, EMI BL01 RN1	C853	87-012-286-080		C-CAP,U 0.01-25 K B
FB501	87-008-372-080		FILTER, EMI BL01 RN1	C859	87-010-831-080		C-CAP,U,0.1-16F
FB502	87-008-372-080		FILTER, EMI BL01 RN1	C860	87-012-286-080		C-CAP,U 0.01-25 K B
FB503	87-008-372-080		FILTER, EMI BL01 RN1	C901	87-012-162-080		C-CAP,U 1P-50 CH
FB701	87-008-372-080		FILTER, EMI BL01 RN1	C902	87-012-165-080		CAP 3P
FB702	87-008-372-080		FILTER, EMI BL01 RN1	C903	87-012-164-080		C-CAP,U 2P-50 C CH
FC103	88-916-161-110		FP-CABLE, 16P 1.25 100MM	C904	86-ZA1-615-080		C-CAP,U 680P-25 J CH
J101	87-A61-575-010		JACK,PIN 6P R/W W/SW HSP-246-V	C905	87-012-162-080		CAP, U 1P-50 CH
J801	87-A60-697-010		JACK,PIN 1P HSP-241V1	C906	87-012-172-080		CAPACITOR CHIP U 10P CH
J901	87-A61-549-010		JACK,PIN 4P YEL W/SW (KM)	C907	87-012-166-080		C-CAP,U 4P-50 CH
L401	87-005-274-080		COIL,68UH K LAL03	C908	87-012-165-080		C-CAP,U 3P-50
L951	87-005-847-080		COIL,2.2UH K CECS	C909	86-ZA1-615-080		C-CAP,U 680P-25 J CH
X501	87-A70-115-010		VIB,XTAL 12.288MHZ	C910	87-012-164-080		CHIP CAP,U 2P-50 CH
X951	87-A70-091-010		VIB,XTAL 4.332MHZ CSA-309	C911	87-012-166-080		C-CAP,U 4P-50 CH
HP C.B				C912	87-012-195-080		C-CAP,U 100P-50CH
C149	87-010-197-080		CAP, CHIP 0.01 DM	C913	86-ZA1-616-080		C-CAP,U 0.01-50 K B (MUR)
C411	87-010-197-080		CAP, CHIP 0.01 DM	C914	86-ZA1-616-080		C-CAP,U 0.01-50 K B (MUR)
C412	87-010-197-080		CAP, CHIP 0.01 DM	C915	86-ZA1-616-080		C-CAP,U 0.01-50 K B (MUR)
CN402	87-A60-063-010		CONN,04P V 9604S-04C	C916	86-ZA1-616-080		C-CAP,U 0.01-50 K B (MUR)
FB401	87-008-372-010		FILTER, EMI BL01 RN1	C917	87-012-178-080		C-CAP,U 18P-50 CH
FB402	87-A50-581-080		C-COIL,S FCM2012H 252705	C918	87-012-172-080		CAPACITOR CHIP U 10P CH
FB403	87-A50-581-080		C-COIL,S FCM2012H 252705	C919	87-012-184-080		C-CAP,U 33P-50 CH
J401	87-A61-546-010		JACK,3.5 BLAK ST W/SW HST3000	C920	87-012-184-080		C-CAP,U 33P-50 CH
J401	87-A61-546-010		JACK,3.5 BLAK ST W/SW HST3000	C921	87-012-180-080		C-CAP,U 22P-50 CH
LED C.B				C922	87-012-174-080		CAP CHIP CERA SS 12P CHJ
LED302	87-A41-046-080		LED,SLRS5B23C ORG	C923	86-ZA1-616-080		C-CAP,U 0.01-50 K B (MUR)
LED303	87-A41-046-080		LED,SLRS5B23C ORG	C924	87-012-176-080		CAP CHIP 2P-50
TUNER C.B				C925	87-012-164-080		C-CAP,U 2P-50 C CH
C772	87-012-286-080		C-CAP,U 0.01-25 K B	C926	86-ZA1-616-080		C-CAP,U 0.01-50 K B (MUR)
C784	87-012-286-080		C-CAP,U 0.01-25 K B	C927	87-012-195-080		C-CAP,U 100P-50CH
C785	87-012-286-080		C-CAP,U 0.01-25 K B	C961	87-012-170-080		C-CAP,U 8P-50 D CH
C786	87-012-286-080		C-CAP,U 0.01-25 K B	C963	87-010-831-080		C-CAP,U,0.1-16F
C788	87-012-167-080		C-CAP,U 5P-50 CH	C971	87-010-381-080		CAP, ELECT 330-16V
C789	87-016-034-080		CHIP CAP U 0.027-25F	C972	87-A11-063-080		C-CAP,S 4.7-10 Z F
				C973	87-012-286-080		C-CAP,U 0.01-25 K B
				C974	87-012-286-080		C-CAP,U 0.01-25 K B
				C976	87-010-831-080		C-CAP,U,0.1-16F
				C979	87-012-195-080		C-CAP,U 100P-50CH
				C981	87-010-553-040		CAP,E 47-16 GAS

REF. NO.	PART NO.	KANRI NO.	DESCRIPTION	REF. NO.	PART NO.	KANRI NO.	DESCRIPTION
C982	87-010-831-080		C-CAP,U,0.1-16F	D903	87-A41-048-040		C-VARI-CAP,HVM16-03 TL
C983	87-A11-132-080		CAP,TC U 0.01-50 K B	J832	87-A61-534-010		TERMINAL,ANT PAL AJ-2021
C984	87-012-286-080		C-CAP,U 0.01-25 K B	J940	87-A60-633-010		CONN,2P H 2.5MM JMT
C985	87-012-195-080		C-CAP,U 100P-50CH	L801	87-A50-694-010		COIL,FM-DET 2 (COILS)
C987	87-012-286-080		C-CAP,U 0.01-25 K B	L802	87-A91-551-010		FLTR,PCFJZH-450 L(TOK)
C990	87-012-195-080		C-CAP,U 100P-50CH	L811	87-005-847-080		COIL,2.2UH CECS
C991	87-012-176-080		C-CAP,U 15P-50	L832	87-005-847-080		COIL,2.2UH CECS
C992	87-012-176-080		C-CAP,U 15P-50	L901	86-ZA1-612-010		COIL,FM ANT/RF-1-Z
C993	87-012-274-080		CHIP CAP,U 1000P-50B	L902	86-ZA1-613-010		COIL,FM ANT/RF-2-Z
C994	87-012-195-080		C-CAP,U 100P-50CH	L903	87-003-098-080		COIL,2.2UH K LAL02
C995	87-012-274-080		CHIP CAP,U 1000P-50B	L904	86-ZA1-612-010		COIL,FM ANT/RF-1-Z
C996	87-012-195-080		C-CAP,U 100P-50CH	L905	86-ZA1-613-010		COIL,FM ANT/RF-2-Z
C997	87-010-831-080		C-CAP,U,0.1-16F	L906	87-005-847-080		COIL,2.2UH CECS
C998	87-010-553-040		CAP,E 47-16 GAS	L907	86-ZA1-614-010		COIL,FM OSC-Z
C999	87-012-286-080		C-CAP,U 0.01-25 K B	L908	88-ZA1-624-010		COIL,FM IFT 7-6.2 (COILS)
CF831	87-008-423-010		CERAMIC FILTER, SFE10.7 MS3G-A	L951	8A-NF8-667-010		COIL,AM PACK 4(TOK)
CF832	82-785-747-010		CF MS2 GHY R	R790	87-012-286-080		CAP, U 0.01-25
CN992	87-099-018-010		CONN,16P V BLK 6216	X991	87-A70-061-010		VIB,XTAL 4.500MHZ CSA-309
D901	87-A41-048-040		C-VARI-CAP,HVM16-03 TL				
D902	87-A41-048-040		C-VARI-CAP,HVM16-03 TL				

チップ抵抗部品コード/CHIP RESISTOR PART CODE

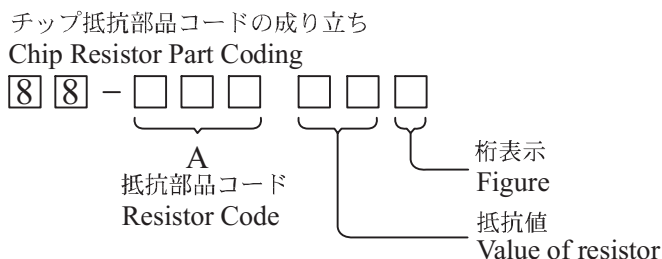

チップ抵抗  
Chip resistor

容量 Wattage	種類 Type	許容誤差 Tolerance	記号 Symbol	寸法/Dimensions (mm)			抵抗コード : A Resistor Code : A	
				外形/Form	L	W		t
1/16W	1005	± 5%	CJ		1.0	0.5	0.35	104
1/16W	1608	± 5%	CJ		1.6	0.8	0.45	108
1/10W	2125	± 5%	CJ		2	1.25	0.45	118
1/8W	3216	± 5%	CJ		3.2	1.6	0.55	128

# TRANSISTOR ILLUSTRATION



E C B

CSC2001  
CSC4115  
2SC1815  
KTA1266  
KTC3198

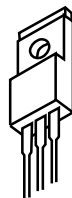

B C E

2SB1370



E C B

2SA1015  
2SC2001



E C B

CSD1489

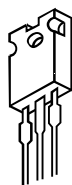

E C B

2SA1357

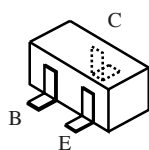

B C E

2SA1235  
2SC3052  
2SC2714  
CMBT5401  
CSD1306

DTC123JK  
KRA107S  
RT1N144C  
RT1P141C

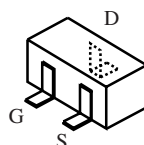

G D S

2SK2158

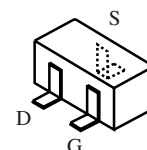

D S G

2SK360

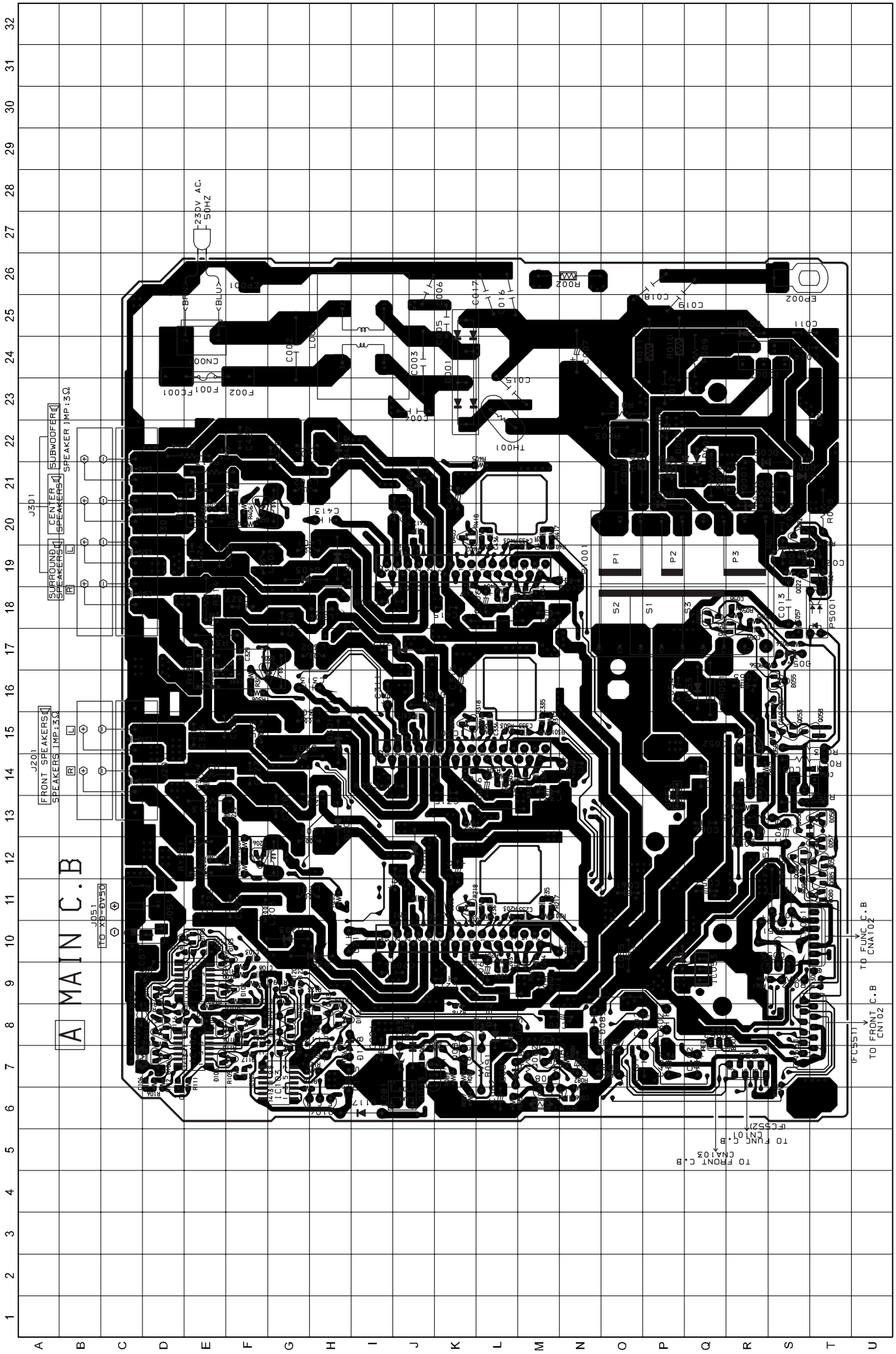

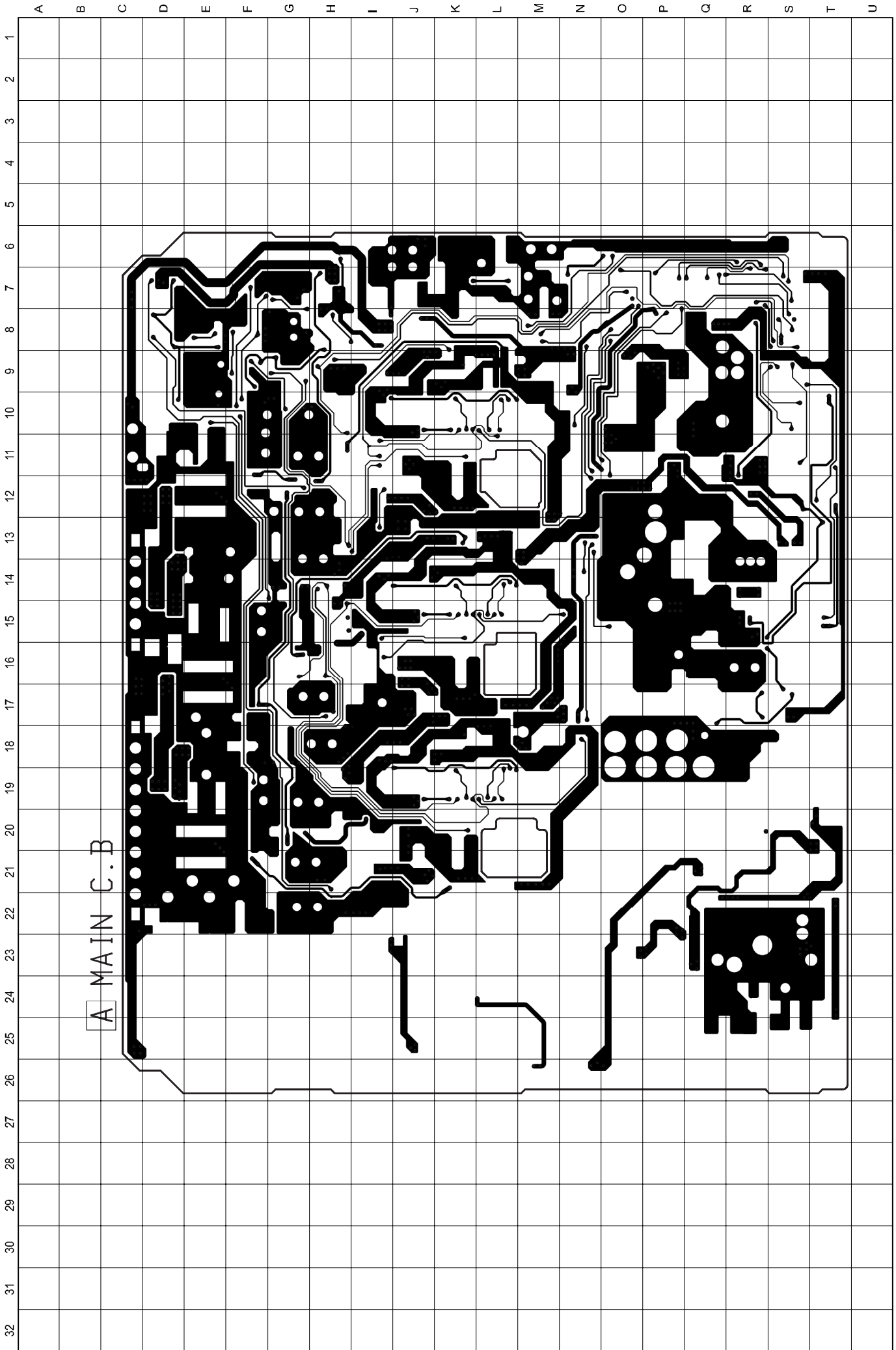

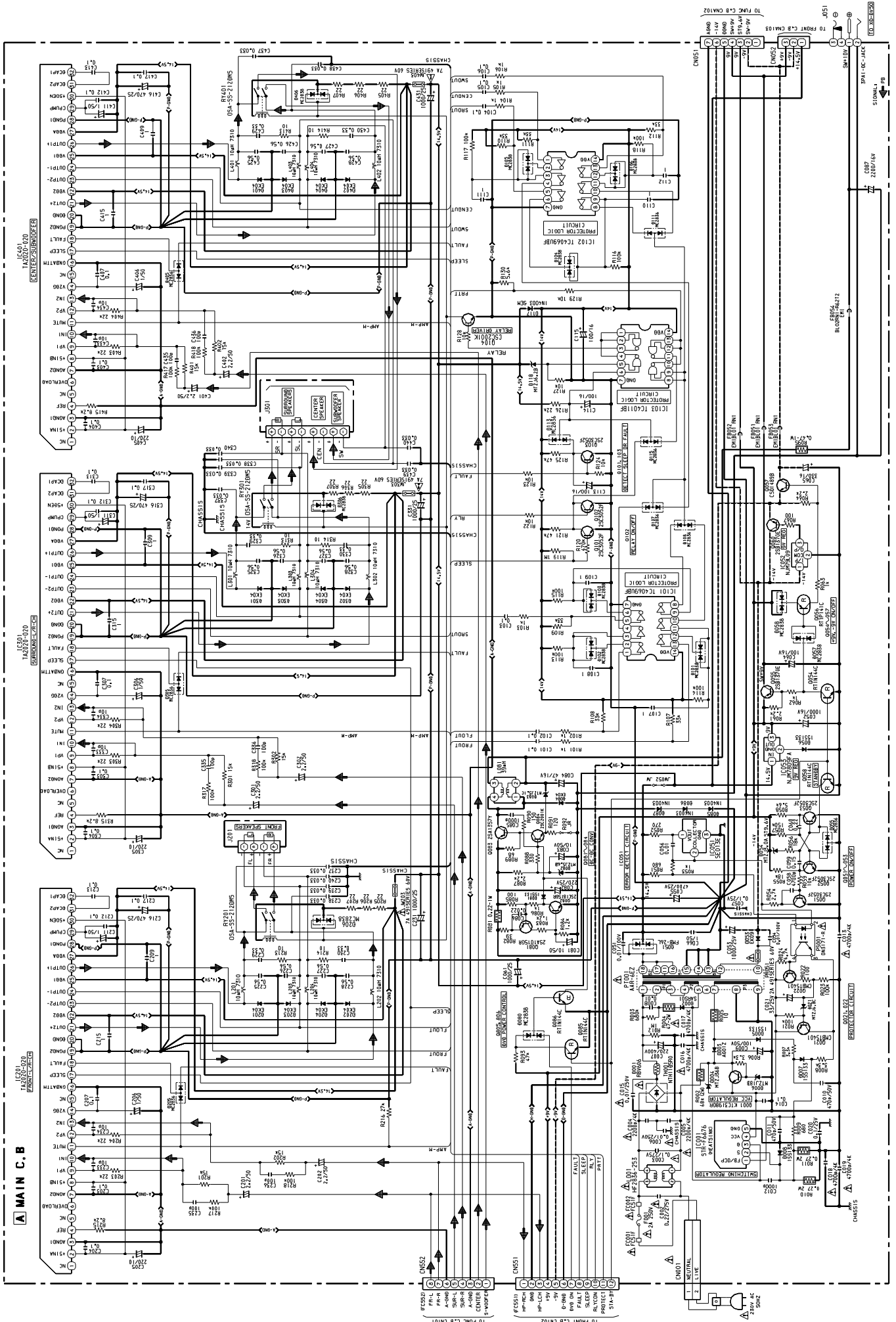

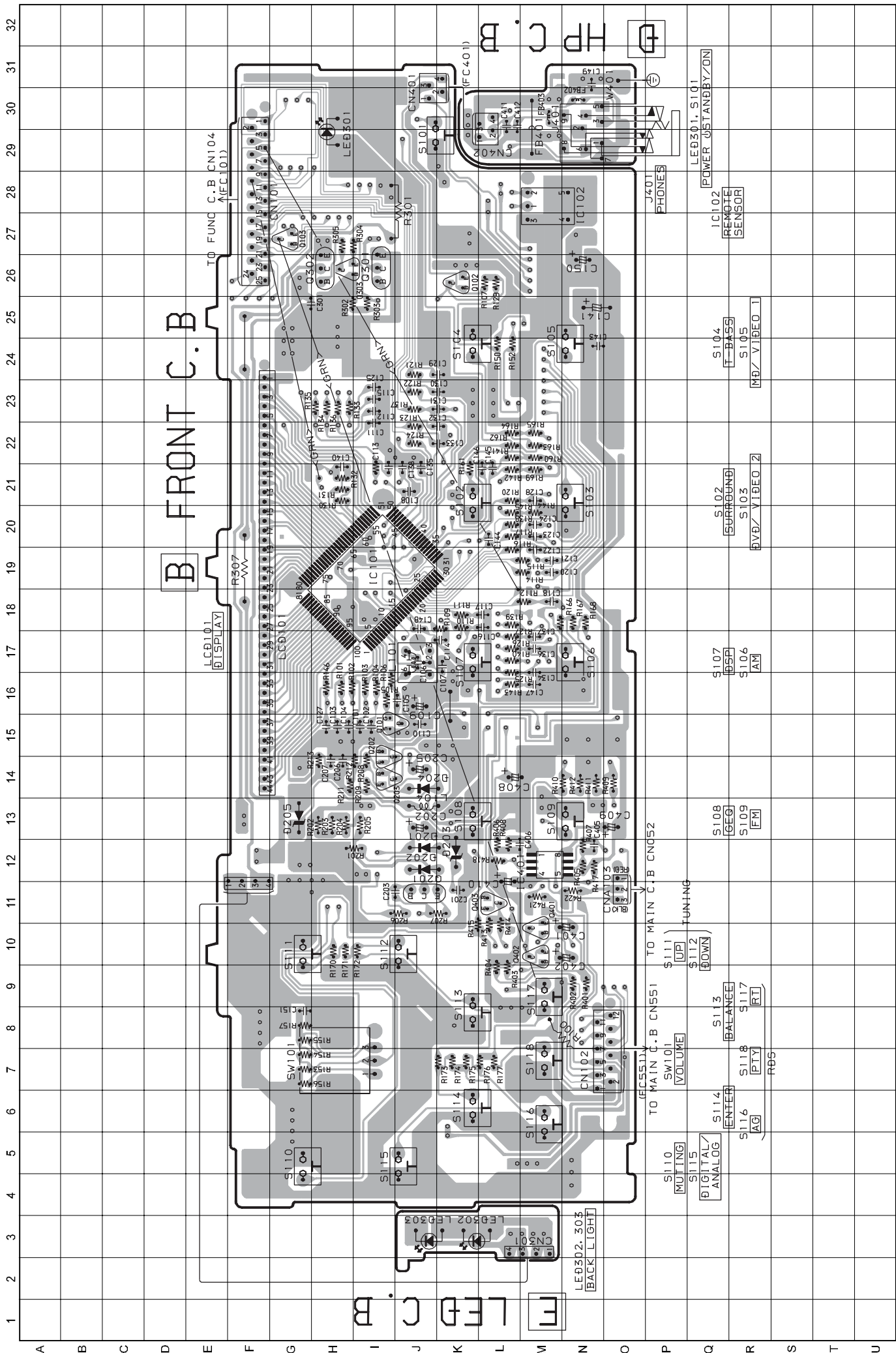



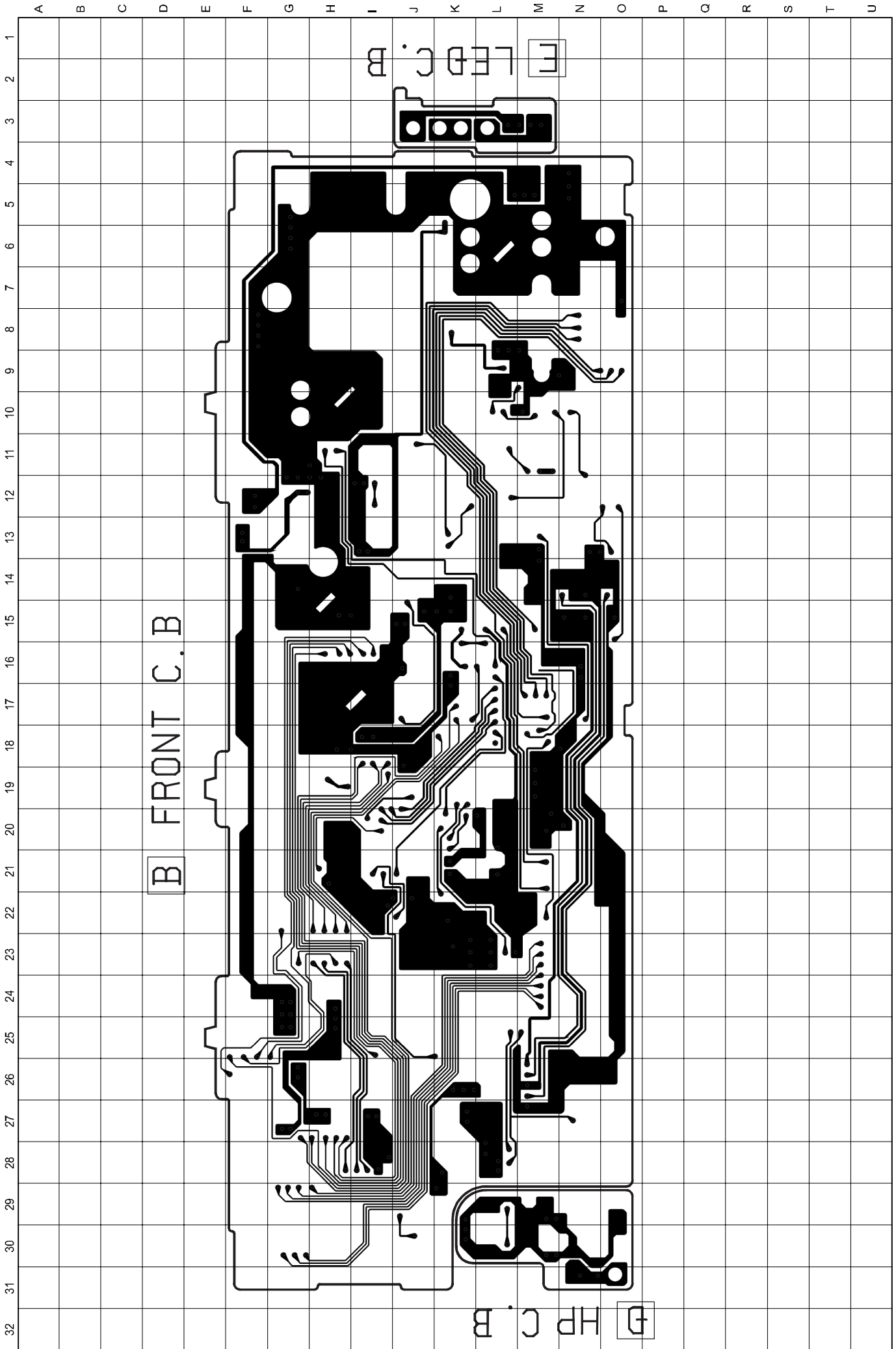

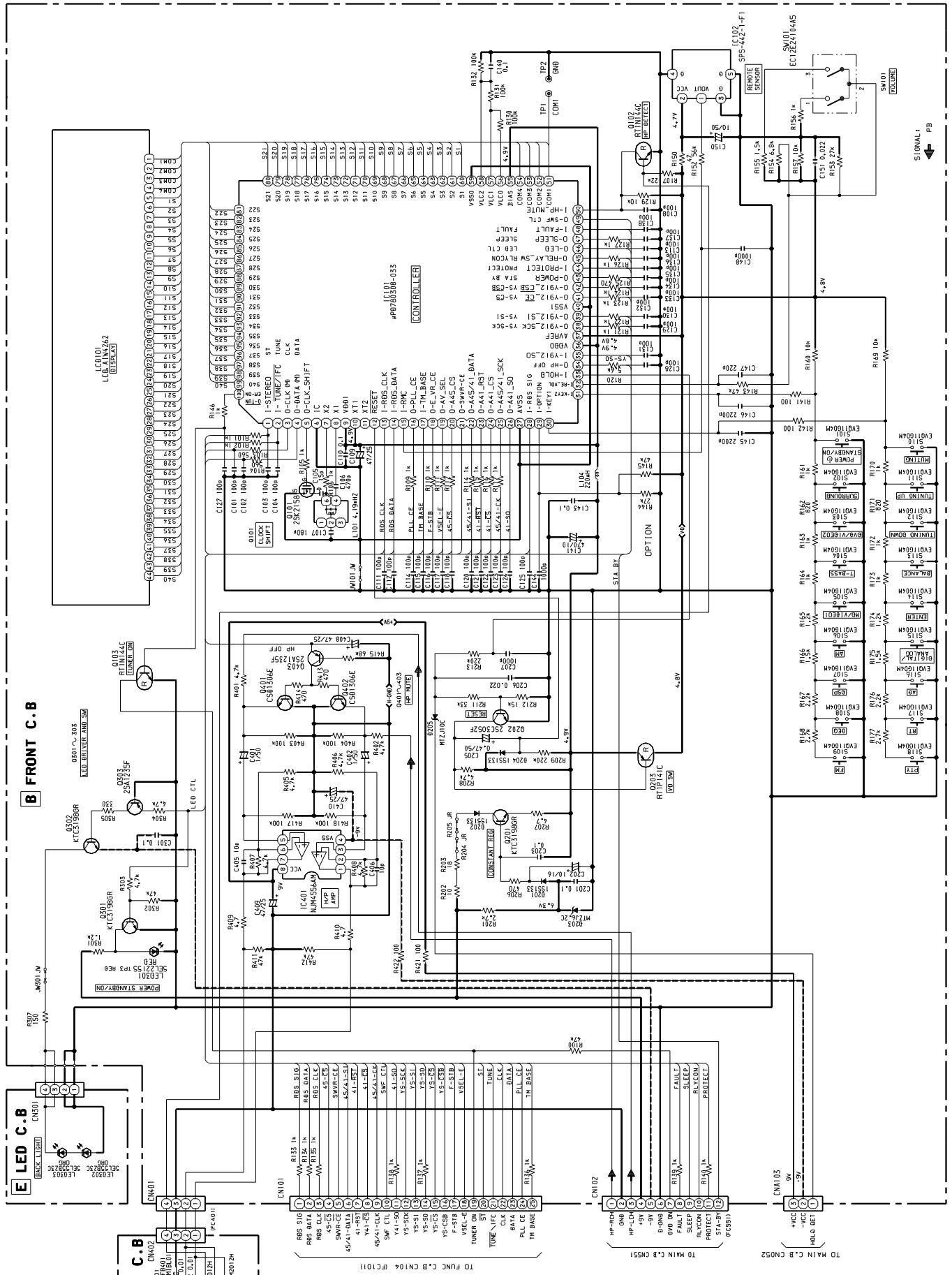

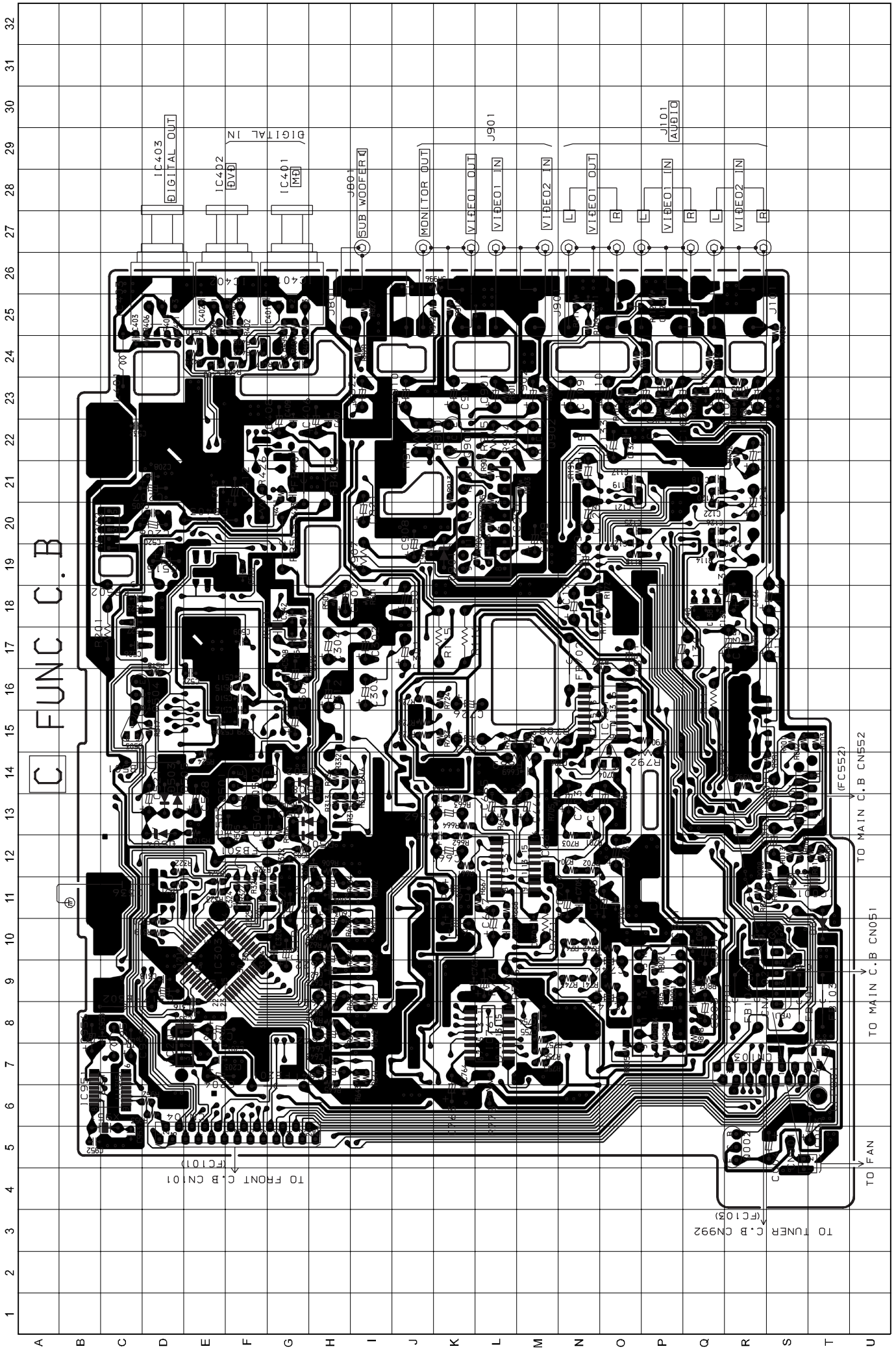

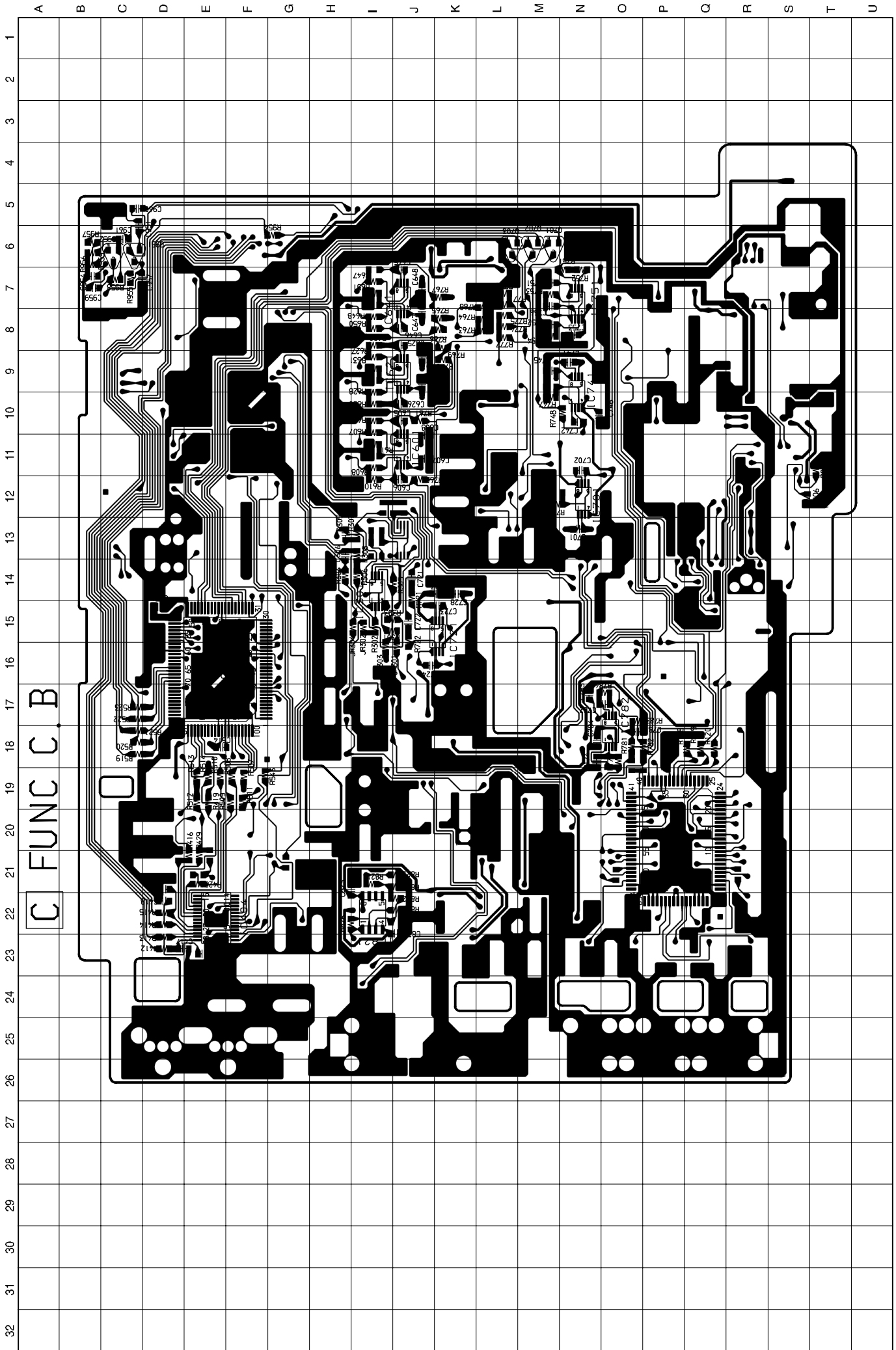

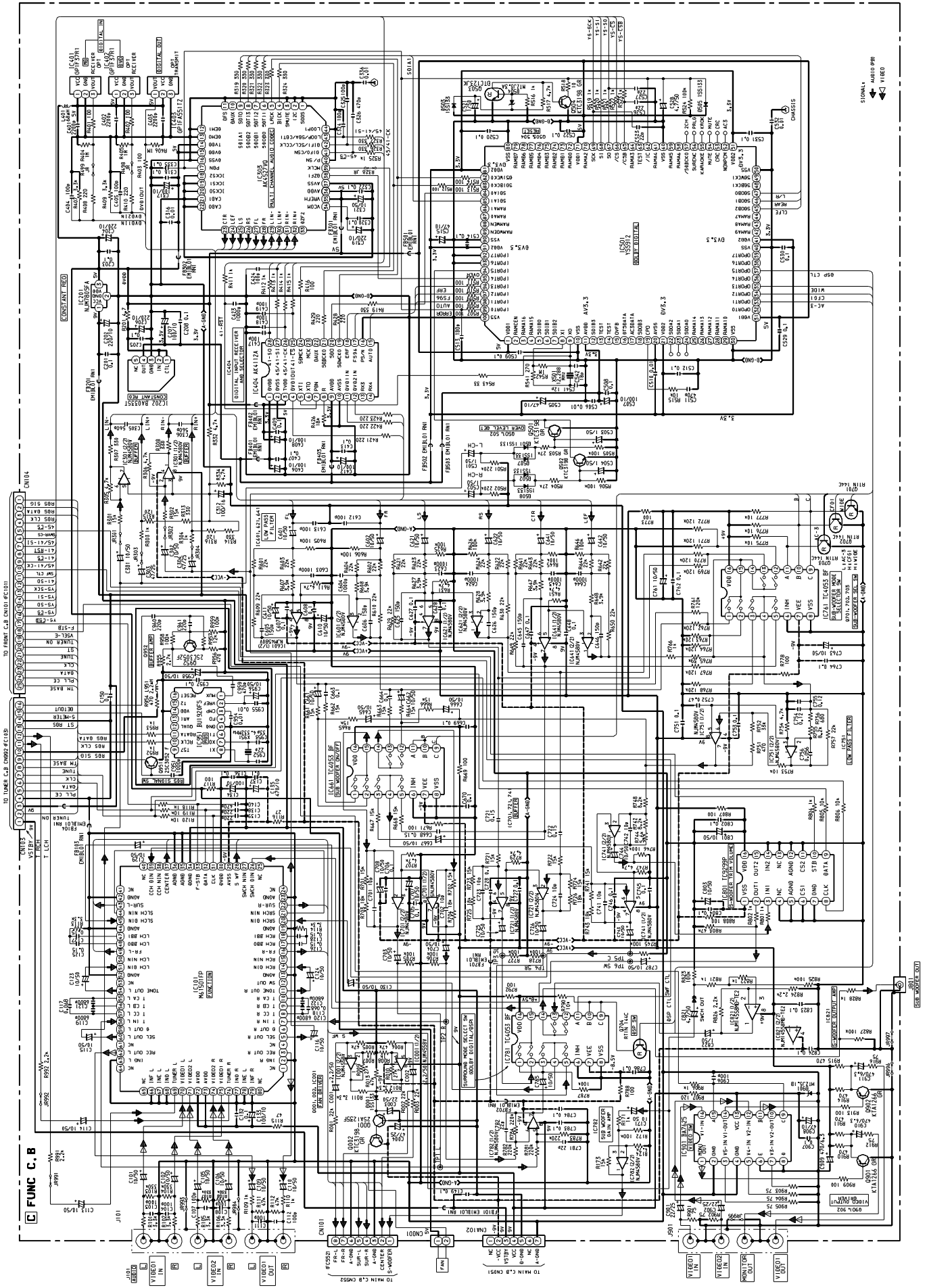

WIRING - 4 (TUNER)

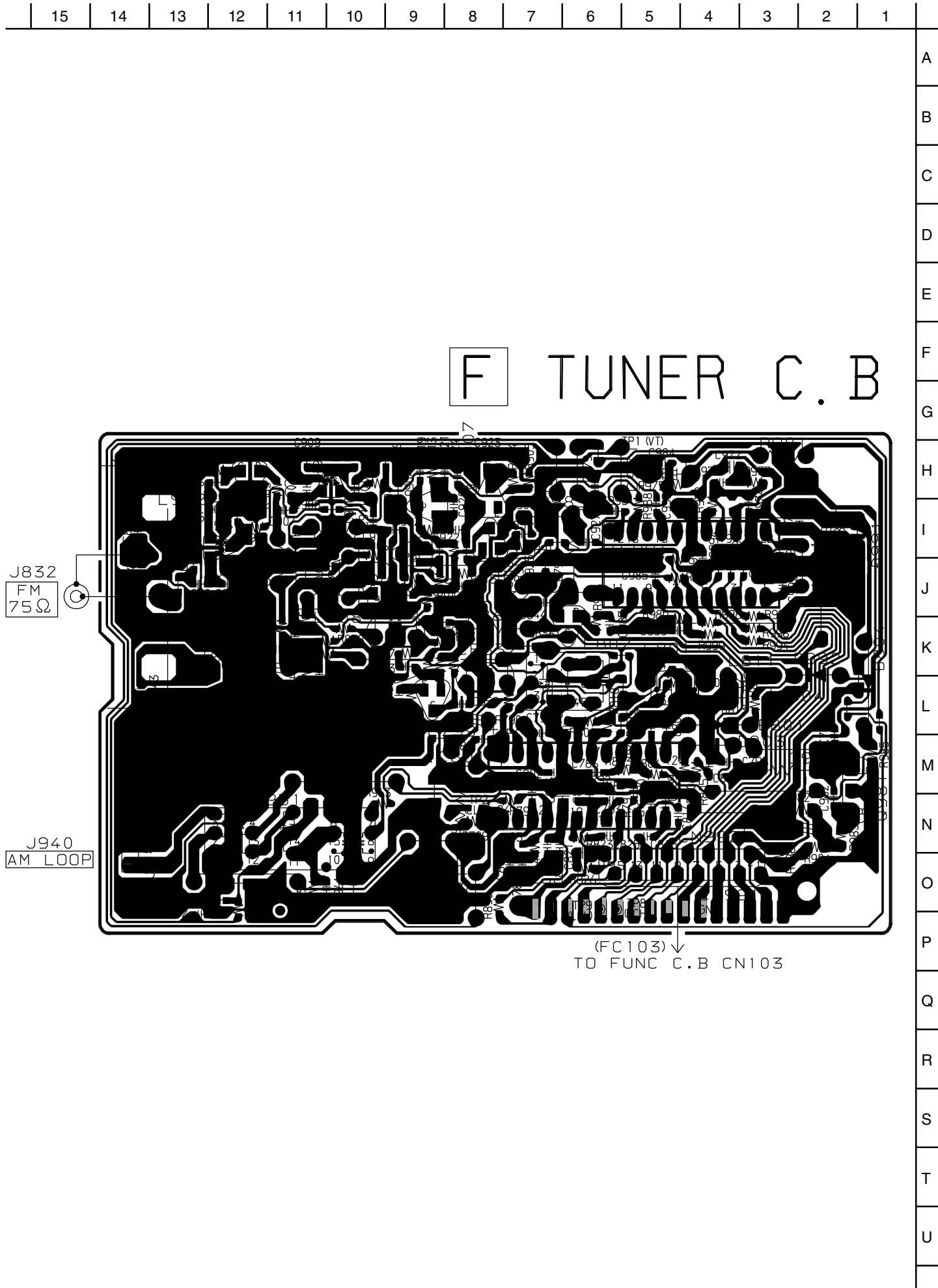







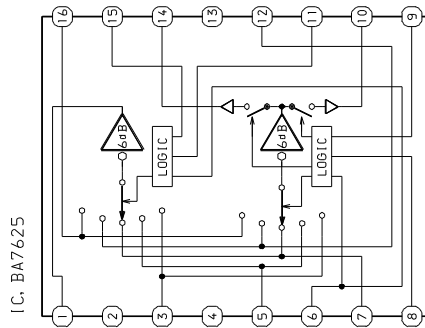
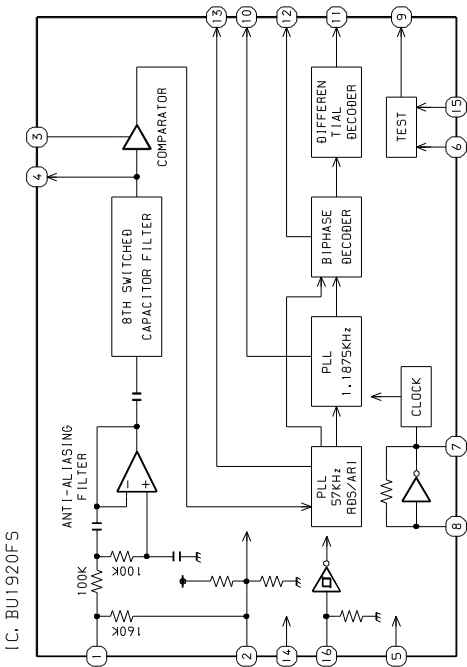
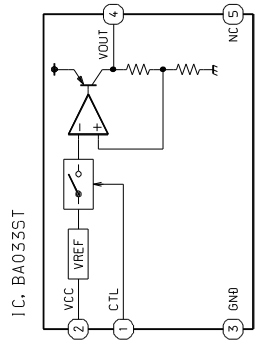

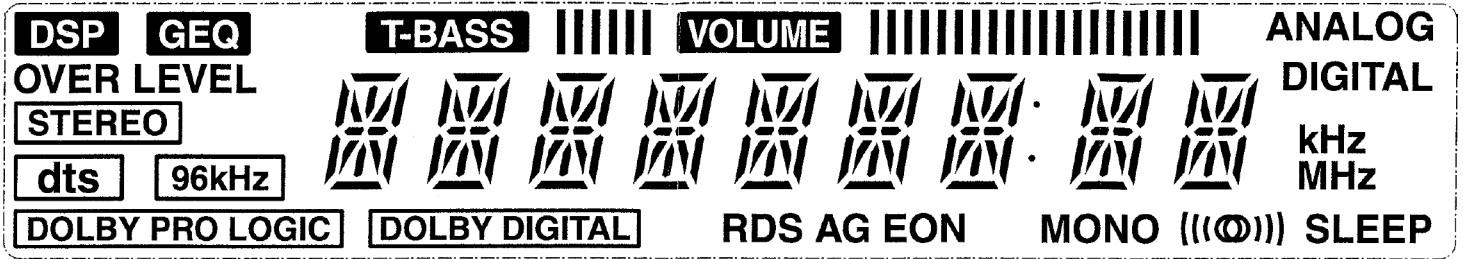

SEGMENT WIRING

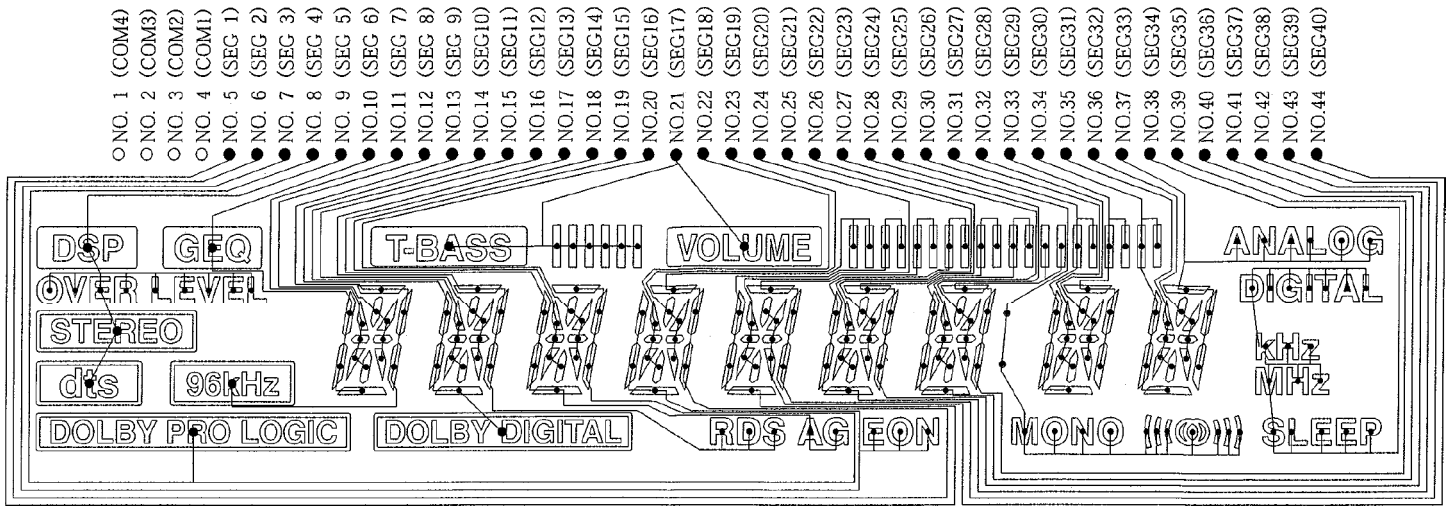

COMMON WIRING

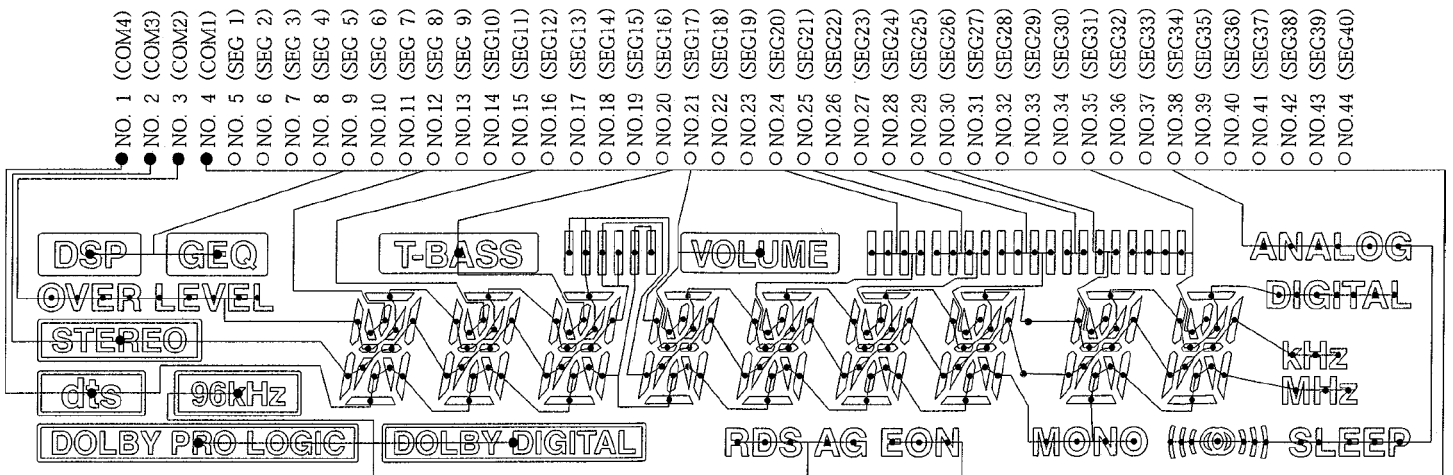

## IC DESCRIPTION

IC, UPD780308-033

Pin No.	Pin Name	I/O	Description
1	I-STEREO	I	Tuner stereo detection input. "L": stereo.
2	I-TUNE/IFC	I	Tuner TUNE/IFC detection input.
3	O-CLK(M)	O	Function IC, PLL, SW VOL clock output.
4	O-DATA(M)	O	Function IC, PLL, SW VOL data output.
5	O-CLK-SHIFT	O	Micro computer shift clock output.
6	IC	—	IC (Connected to GND).
7	X2	—	4.19MHz oscillator circuit.
8	X1	—	4.19MHz oscillator circuit.
9	VDD1	—	Power supply (+5.0V).
10	XT1	—	32.768kHz (sub clock) circuit. (Connected to VDD)
11	XT2	—	32.768kHz (sub clock) circuit. (Not used)
12	RESET	I	Reset input.
13	I-RDS-CLK	I	RDS clock input.
14	I-RDS-DATA	I	RDS data input.
15	I-RMC	I	Remote control signal input. (Active "L")
16	O-PLL-CE	O	Tuner PLL IC chip enable output.
17	I-TM-BASE	I	Reference clock input for timer watch.
18	O-E-VR-CE	O	Function IC chip enable output.
19	O-AV-SEL	O	Video signal select output.
20	O-A45-CS	O	AK4527 chip enable output.
21	O-SWVR-CE	O	TC9299 chip enable output.
22	O-A45/41-DATA	O	AK4527 data output.
23	O-A41-RST	O	AK4112 reset output.
24	O-A41-CS	O	AK4112 chip select output.
25	O-A45/41-SCK	O	AK4112 clock output / AK4527 clock output.
26	O-A41-SO	O	AK4112 serial data output.
27	AVSS	—	GND.
28	I-RDS SIG	I	RDS signal input.
29	I-OPTION	I	Option input.
30	I-KEY1	I	Key input 1.
31	I-KEY2	I	Key input 2.
32	I-RE-VOL	I	Main volume input (rotary encoder) AD input.
33	I-HOLD	I	Error detect.
34	O-HP OFF	O	Mute output terminal when inserting HP.
35	I-Y912-SO	I	YSS912 data input.
36	VDD0	—	Power supply (+5.0V).
37	AVREF	—	Power supply for analog circuit (+5.0V).
38	O-Y912-SCK	O	YSS912 clock output.
39	O-Y912-SI	O	YSS912 data output.
40	VSS1	—	GND.
41	O-Y912-CE	O	YSS912 chip select output.
42	O-Y912-CSB	O	YSS912 SUBDSP chip select output.

Pin No.	Pin Name	I/O	Description
43	O-POWER	O	System power on (Active "H").
44	I-PROTECT	I	Protector input (Active "H").
45	O-RELAY-SW	O	Relay output.
46	O-LED	I	LED input (Active "L").
47	O-SLEEP	O	Sleep output (Active "L").
48	I-FAULT	I	Fault input (Active "H").
49	O-SWF CTL	O	Subwoofer control output.
50	I-HP-MUTE	I	Detect headphone plug insertion.
51 ~ 54	COM4 ~ COM1	O	LCD common output (COM4 ~ COM1).
55	BIAS	—	Power supply for LCD drive. (Connected to VDD)
56	VLC0	—	LCD voltage for LCD drive (VLC0).
57	VLC1	—	LCD voltage for LCD drive (VLC1).
58	VLC2	—	LCD voltage for LCD drive (VLC2).
59	VSS0	—	GND.
60 ~ 99	S1 ~ S40	O	LCD segment output (S1 ~ S40).
100	O-TUNER-ON	O	Tuner on output.

## IC, YSS912

Pin No.	Pin Name	I/O	Description
1	VDD1	-	+5V power supply for (I/Os).
2	RAMCEN	O	External SRAM interface / CE. (Not used)
3	RAMA16	O	External SRAM interface address 16. (Not used)
4	RAMA15	O	External SRAM interface address 15. (Not used)
5~7,12	SDIB0~2, SDIB3	I	PCM input 0~3 to Sub DSP. (Not used)
8	XI	I	Crystal oscillator connection (12.288MHz).
9	XO	O	Crystal oscillator connection.
10	VSS	-	Ground.
11	AVDD	-	+3.3V power supply (for PLL circuit).
13,14	TEST	-	Test terminal (to be open in normal use). (Not used)
15	OVFB	O	Detection of overflow at Sub DSP. (Not used)
16	DTSDATA	O	Detection of DTS data. (Not used)
17	AC3DATA	O	Detection of AC-3 data. (Not used)
18	SDOB3	O	PCM output from Sub DSP. (Not used)
19	CPO	O	Output terminal for PLL, to be connected to ground through the external analog filter circuit.
20	AVSS	-	Ground (for PLL circuit).
21	VDD2	-	+3.3V power supply (for core logic).
22	SDOA2	O	PCM output from Main DSP (C, LFE). (Not used)
23	SDOA1	O	PCM output from Main DSP (LS, RS). (Not used)
24	SDOA0	O	PCM output from Main DSP (L, R). (Not used)
25~29	RAMA14~10	O	External SRAM Interface address 14 ~ 10. (Not used)
30	VSS	-	Ground.
31	VDD1	-	+5V power supply (for I/Os).
32	OPORT0	O	Output port for general purpose. (Not used)
33~35	OPORT1~3	O	Output port for general purpose.
36	OPORT4	O	Output port for general purpose. (Not used)
37	OPORT5	O	Output port for general purpose.
38	OPORT6	O	Output port for general purpose. (Not used)
39	OPORT7	O	Output port for general purpose. (Not used)
40	VSS	-	Ground.
41	VDD2	-	+3.3V power supply (for core logic).
42~44	RAMA9~7	O	External SRAM interface address 9~7. (Not used)
45~47	SDOB2~0	O	PCM output from Sub DSP.
48	SDBCK1	I	Bit clock input for SDOA, SDIB, SDOB. (Not used)
49	SDWCK1	I	Word clock input for SDOA,SDIB,SDOB. (Not used)
50	VSS	-	Ground.
51	VDD2	-	+3.3V power supply (for core logic).
52	NONPCM	O	Detection of non-PCM data. (Not used)
53	CRC	O	Detection of AC-3 CRC error. (Not used)
54	MUTE	O	Detection of auto mute. (Not used)
55	KARAOKE	O	Detection of AC-3 karaoke data. (Not used)
56	SURENC	O	Detection of AC-3 2/0 mode Dolby surround encoded input. (Not used)

Pin No.	Pin Name	I/O	Description
57	/SDBCK0	O	Inverted SDBCK0 clock output . (Not used)
58,59	RAMA6,5	O	External SRAM interface address 6, 5. (Not used)
60	VSS	-	Ground.
61	RAMA4	O	External SRAM interface address 4. (Not used)
62	/IC	I	Initial clear.
63	TEST	-	Test terminal (Not used).
64	RAMA3	O	External SRAM interface address 3. (Not used)
65	/CSB	I	Sub DSP chip select.
66	/CS	I	Microprocessor interface chip select.
67	SO	O	Microprocessor interface serial data output.
68	SI	I	Microprocessor interface / Sub DSP serial data input.
69	SCK	I	Microprocessor interface / Sub DSP clock input.
70	RAMA2	O	External SRAM interface address 2. (Not used)
71	VDD1	-	+5V power supply (for I/Os).
72~79	RAMD0~7	I/O	External SRAM interface data (STREAM0~7 output when external SRAM is not in use). (Not used)
80	VSS	-	Ground.
81	VDD2	-	+3.3V power supply (for core logic).
82	DSIWCK0	I	Word clock input for SDIA, SDOA, SDIB, SDOB.
83	SDIBCK0	I	Bit clock input for SDIA, SDOA, SDIB, SDOB.
84	SDIA0	I	AC-3 bitstream (or PCM ) data input for Main DSP.
85	SDIA1	I	AC-3 bitstream (or PCM ) data input for Main DSP.
86,87	RAMA1,0	O	External SRAM interface address 1, 0. (Not used)
88	RAMWEN	O	External SRAM interface / WE. (Not used)
89	RAMWOEN	O	External SRAM interface / OE. (Not used)
90	VSS	-	Ground.
91	VDD2	-	+3.3V power supply (for core logic).
92,93	IPORT7,6	I	Input port for general purpose. (Connected to VSS)
94 ~ 99	IPORT5 ~ 0	I	Input port for general purpose.
100	VSS	-	Ground.

## IC, AK4112A

Pin No.	Pin Name	I/O	Description
1	DVDD	-	Digital power supply pin, 3.3V.
2	DVSS	-	Digital ground pin.
3	TVDD	-	Input buffer power supply pin, 3.3V or 5V.
4	DVD1OUT	O	Transmit channel (through data) output pin in serial mode.
5	XTI	I	Crystal input pin.
6	XTO	O	Crystal output pin. (Not used)
7	PDN	I	Power-down mode pin. When "L", the AK4112A is power-down and reset.
8	R	-	External resistor pin. 18kohms +/- 1% resistor to AVSS externally.
9	AVDD	-	Analog power supply pin.
10	AVSS	-	Analog ground pin.
11	DVD1 IN	I	Receiver channel 1 in serial mode.
12	DVD2 IN	I	Receiver channel 2 in serial mode.
13	RX3	I	Receiver channel 3 in serial mode. (Not used)
14	RX4	I	Receiver channel 4 in serial mode. (Not used)
15	AUTO	O	Non-PCM detect pin. "L": No detect, "H": Detect.
16	PS/N	I	Parallel / serial select pin. "L": Serial mode, "H": Parallel mode.
17	FS96	O	96kHz sampling detect pin. (Crystal Mode) "H": XFS96=1, "L": XFS96=0. (RX Mode) "H": fs=88.2kHz or more, "L": fs=54kHz or less.
18	ERF	O	Unlock & parity error output pin. "L": No error, "H": Error.
19	SDWCK0	I/O	Output channel clock pin.
20	SDO	O	Audio serial data output pin.
21	SDBCK0	I/O	Audio serial data clock pin.
22	DAUX	I	Auxiliary audio data input pin. (Not used)
23	MCK	O	Master clock 2 output pin. (Not used)
24	SDMCK	O	Master clock 1 output pin.
25	41- $\overline{CS}$	I	Chip select pin in serial mode.
26	45/41-CK	I	Control data clock pin in serial mode.
27	45/41-SI	I	Control data input pin in serial mode.
28	41-SO	O	Control data output pin in serial mode.

## IC, M61501FP

Pin No.	Pin Name	I/O	Description
1	NC	-	Not connected.
2	ING R	I	Right input selector G input. (Connected to GND)
3	REC OUT R	O	Right input B through output.
4	NC	-	Not connected.
5	SEL OUT R	O	Right signal after 0/-6 dB output.
6	D OUT R	I	Right tone A signal input. (Not used)
7	T IN R	I	Right tone B signal input.
8	T CC R	I	Right tone C control.
9	T CB R	I	Right tone B control.
10	T CA R	I	Right tone A control.
11	TONE OUT R	O	Right tone signal output.
12	SW OUT	O	L+R+C signal output. (Not used)
13	AGND	-	R channel analog GND.
14	RCH DIN	I	R channel A select signal input.
15	RCH NIN	I	R channel B select signal input. (Not used)
16	FR-R	O	R channel signal output.
17	RCH BB0	O	R channel bass boost control output.
18	RCH BB1	I	R channel bass boost control input.
19	AGND	-	SR channel analog GND.
20	SRCH DIN	I	SR channel A select signal input.
21	SRCH NIN	I	SR channel B select signal input.
22	SUR-R	O	SR channel signal output.
23	AGND	-	SW channel analog GND.
24	NC	-	Not connected.
25	NC	-	Not connected.
26	SWCH DIN	I	SW channel A select signal input.
27	SWCH NIN	I	SW channel B select signal input. (Not used)
28	S WF	O	SW channel signal output.
29	AVSS	-	Negative analog power supply.
30	DVDD	-	Digital power supply.
31	CLK	I	Digital CLOCK input from Micon.
32	DATA	I	Digital DATA input from Micon.
33	F-STB	I	Digital LATCH input from Micon.
34	DGND	-	Digital GND.
35	AGND	-	Right analog GND (except channel).
36	AGND	-	Left analog GND (except channel).
37	CENTER	O	C channel signal output.
38	CCH NIN	I	C channel B select signal input. (Not used)
39	CCH DIN	I	C channel A select signal input.
40	NC	-	Not connected.
41	NC	-	Not connected.
42	AGND	-	C channel analog GND.



Pin No.	Pin Name	I/O	Description
43	SUR-L	O	SL channel signal output.
44	SLCH NIN	I	SL channel B select signal input.
45	SLCH DIN	I	SL channel A select signal input.
46	AGND	-	SL channel analog GND.
47	LCH BB1	I	L channel bass boost control input.
48	LCH BB0	O	L channel bass boost control input.
49	FR-L	O	L channel signal output.
50	LCH NIN	I	L channel B select signal input. (Not used)
51	LCH DIN	I	L channel A select signal input.
52	AGND	-	L channel analog GND.
53	NC	-	Not connected.
54	TONE OUT L	O	Left tone signal output.
55	T CA L	I	Left tone A control.
56	T CB L	I	Left tone B control.
57	T CC L	I	Left tone C control.
58	T IN L	I	Left tone B signal input.
59	D OUT L	I	Left tone A signal input. (Not used)
60	SEL OUT L	O	Left signal after 0/-6 dB output.
61	NC	-	Not connected.
62	REC OUT L	O	Left signal A through output.
63	ING L	I	Left input selector G input. (Connected to GND)
64	NC	-	Not connected.
65	NC	-	Not connected.
66	INF L	I	Left input selector F input. (Connected to GND)
67	INE L	I	Left input selector E input. (Connected to GND)
68	IND L	I	Left input selector D input. (Connected to GND)
69	TUNER L	I	Left input selector C input.
70	VIDEO1 L	I	Left input selector B input.
71	VIDEO2 L	I	Left input selector A input.
72	AVDD	-	Positive analog power supply.
73	AVDD	-	Positive analog power supply.
74	VIDEO2 R	I	Right input selector A input.
75	VIDEO1 R	I	Right input selector B input.
76	TUNER R	I	Right input selector C input.
77	IND R	I	Right input selector D input. (Connected to GND)
78	INE R	I	Right input selector E input. (Connected to GND)
79	INF R	I	Right input selector F input. (Connected to GND)
80	NC	-	Not connected.

## IC, AK4527VQ

Pin No.	Pin Name	I/O	Description
1	SDOS	I	SDTO source select pin. (Note 1) "L": Internal ADC output, "H": DAUX input. (Connected to DVSS)
2	I2C	I	Control mode select pin. (Connected to DVSS)
3	SMUTE	I	Soft mute pin. (Note 1) When this pin goes to "H", soft mute cycle is initialized. When returning to "L", the output mute releases. (Connected to DVSS)
4	BICK	I	Audio serial data clock pin.
5	LRCK	I	Input channel clock pin.
6	SDOB0 SDTI1	I	DAC1 audio serial data input pin.
7	SDOB1 SDTI2	I	DAC2 audio serial data input pin.
8	SDOB2 SDTI3	I	DAC3 audio serial data input pin.
9	SDIA1 SDTO	O	Audio serial data output pin.
10	DAUX	I	AUX audio serial data input pin. (Not used)
11	DFS	I	Double speed sampling mode pin. (Note 1) "L": Normal speed, "H": Double speed. (Connected to DVSS)
12	DEM1	I	De-emphasis 1 pin. (Note 2) (Connected to DVSS)
13	DEM0	I	De-emphasis 0 pin. (Note 2) (Connected to DVSS)
14	TVDD	-	Output buffer power supply pin, 2.7V ~ 5.5V.
15	DVDD	-	Digital power supply pin, 4.5V ~ 5.5V.
16	DVSS	-	Digital ground pin, 0V.
17	PDN	I	Power-down & reset pin. When "L", the AK4527 is powered-down and the control registers are reset to default state. If the state of CAD0-1 changes, then the AK4527 must be reset by PDN.
18	ICKS2	I	Input clock select 2 pin. (Note 1) (Connected to AVSS)
19	ICKS1	I	Input clock select 1 pin. (Note 1) (Connected to AVSS)
20	ICKS0	I	Input clock select 0 pin. (Note 1) (Connected to AVSS)
21	CAD1	I	Chip address 1 pin. (Connected to AVSS)
22	CAD0	O	Chip address 0 pin. (Connected to AVSS)
23	CTR	O	DAC3 Lch analog output pin.
24	LEF	O	DAC3 Rch analog output pin.
25	LS	O	DAC2 Lch analog output pin.
26	RS	O	DAC2 Rch analog output pin.
27	FL	O	DAC1 Lch analog output pin.
28	FR	O	DAC1 Rch analog output pin.
29	LIN-	I	Lch analog negative input pin.
30	LIN+	I	Lch analog positive input pin.
31	RIN-	I	Rch analog negative input pin.
32	RIN+	I	Rch analog positive input pin.
33	DZF2	O	Zero input detect 2 pin (Note 3) When the input data of the group 1 follow total 8192 LRCK cycles with "0" input data, this pin goes to "H". This pin is always "L" if P/S="H". (Not used)

Pin No.	Pin Name	I/O	Description
34	VCOM	O	Common voltage output pin, AVDD/2. Large external capacitor around 2.2μF is used to reduce power-supply noise.
35	VREFH	I	Positive voltage reference input pin, AVDD.
36	AVDD	-	Analog power supply pin, 4.5 ~ 5.5V.
37	AVSS	-	Analog ground pin, 0V.
38	DZF1	O	Zero input detect 1 pin. (Note 3) When the input data of the group 1 follow total 8192 LRCK cycles with "0" input data, this pin goes to "H". This pin is always "L" if P/S = "H".
39	MCLK	I	Master clock input pin.
40	P/SN	I	Parallel/serial select pin. "L": serial control mode, "H": parallel control mode. (Connected to DVSS)
41	DIF0/CSN	I	Audio data interface format 0 pin in parallel control mode/chip select pin in serial control mode.
42	DIF1/SCL/CCLK	I	Audio data interface format 1 pin in parallel control mode/ control data clock pin in serial control mode.
43	LOOP/SDA/CDT1	I	Loopback mode 0 pin in parallel control mode. Enables digital loop-back from ADC to 3 DACs. Control data input pin in serial control mode.
44	LOOP1	I	Loopback mode 1 pin. (Note 1) Enables all 3 DAC channels to be input from SDTI1. (Connected to DVSS)

- Notes:
1. SDOS, SMUTE, DFS, ICKS2-0 and Loop1 pins are ORed with register data if P/S = "L".
  2. DEM1-0 pins are ORed with register data of DEMA1-C0 bits if P/S = "L".  
DEM1 pin = "H" : DEMA1 = DEMB1 = DEMC1 = "1",  
DEM0 pin = "H" : DEMA0 = DEMB0 = DEMC0 = "1".
  3. The group 1 and 2 can be selected by DZFM2-0 bits if P/S = "L".
  4. All input pins should not be left floating.

Pin No.	Pin Name	I/O	Description
1,5,15	NC	-	Not connected.
2,8	+5INA, +5INB	-	Digital +5V, analog +5V.
3	AGND1	-	Analog ground.
4	REF	-	Reference resistor.
6	OVERLOAD	O	A logic low output indicates the input signal has overloaded the amplifier. (Not used)
7	AGND2	-	Analog ground.
9,12	VP1,VP2	I	Input stage feedback drive.
10,13	IN1,IN2	I	Single-ended inputs.
11	MUTE	I	When set to logic high, both amplifiers are muted and in low power (idle) mode. When low (grounded), both amplifiers are fully operational. If left floating, the device stays in the mute mode. Ground if not used.
14	V2DG	-	Bias stabilization capacitor.
16	GNBATTM	-	Analog ground.
17	SLEEP	I	When set to logic high, device goes into low power mode. If not used this pin should be grounded.
18	FAULT	O	A logic high output indicates thermal overload, or an output is shorted to ground or another output.
19,28	PGND2,PGND1	-	Power ground (High current).
20	DGND	-	Digital ground.
21	OUTP2+	O	Bridged output.
22,25	VDD2,VDD1	-	+13.5V power (High current).
23	OUTP2-	O	Bridged output.
24	OUTP1-	O	Bridged output.
26	OUTP1+	O	Bridged output.
27	VDDA	-	Analog +13.5V.
29	CPUMP	O	Charge pump output capacitor.
30	+5GEN	-	Regulated +5V source used to supply power to pins 2 & 8.
31,32	DCAP2,DCAP1	-	Charge pump switching capacitor.

## ADJUSTMENT

### < TUNER SECTION >

1. Clock Frequency Check  
Settings : • Test point : TP2 (CLK)  
Method : Set to AM 1602kHz and check that the test point is 2052kHz  $\pm$  45Hz.
2. AM VT Check  
Settings : • Test point : TP1 (VT)  
Method : Set to AM 1602kHz and check that the test point is less than 8.0V. Then set to AM 531kHz and check that the test point is more than 0.6V.
3. AM Tracking Adjustment  
Settings : • Test point : TP8 (Rch), TP9 (Lch)  
• Adjustment location : L951 (1/3)  
Method : Set to AM 999kHz and adjust L951 (1/3) so that the test point becomes maximum.
4. AM IF Adjustment  
Settings : • Test point : TP8 (Rch), TP9 (Lch)  
• Adjustment location :  
L802 ..... 450kHz
5. FM VT Adjustment  
Settings : • Test point : TP1 (VT)  
• Adjustment location : L907  
Method : Set to FM 108.0MHz and adjust L907 so that the test point is 7.0V  $\pm$  0.05V. Then set to FM 87.5MHz and check that the test point is more than 0.5V.
6. FM Tracking Adjustment  
Settings : • Test point : TP8 (Rch), TP9 (Lch)  
• Adjustment location : L901, L902, L904, L905  
Method : Set to FM 108.0MHz and adjust L901, L902, L904, L905 so that the test point becomes maximum with minimum distortion.
7. FM Tracking Check  
Settings : • Test point : TP8 (Rch), TP9 (Lch)  
Method : Set to FM 98.0MHz and check that the test point is less than 13dB $\mu$ V.
8. DC Balance / Mono Distortion Adjustment  
Settings : • Test point : TP3, TP4 (DC balance)  
• Adjustment location : L801  
• Input level : 60dB $\mu$ V  
Method : Set to FM 98.0MHz and adjust L801 so that the voltage between TP3 and TP4 is 0V  $\pm$  500mV. Next, check the distortion is less than 1.2 %.

MECHANICAL EXPLODED VIEW 1 / 1

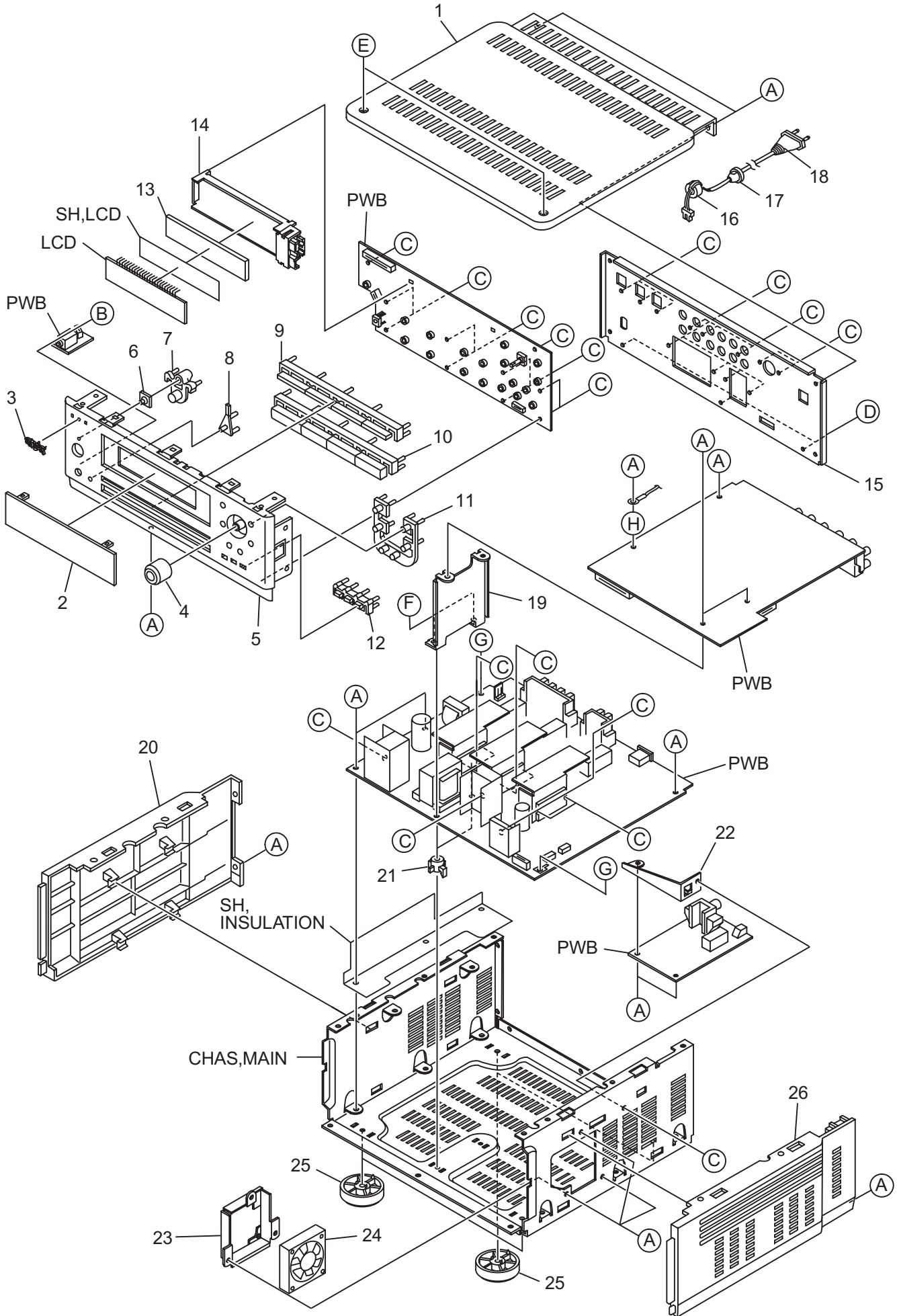

# MECHANICAL PARTS LIST 1 / 1

REF. NO.	PART NO.	KANRI NO.	DESCRIPTION	REF. NO.	PART NO.	KANRI NO.	DESCRIPTION
1	8A-AR6-004-010		PANEL, TOP	21	88-AR1-218-010		HLDR, PWB H8.9
2	8A-AR6-044-010		WINDOW, DISP EZ	22	8A-AR6-212-010		HLDR, PWB TU
3	8A-AV6-008-010		BADGE, AIWA 25 SIL	23	8A-AR6-214-010		HLDR, FAN
4	8A-AR6-010-010		KNOB, RTRY VOL	24	8Z-CL1-663-010		FAN, MF40D-12-200MM
5	8A-AR6-021-010		CABI, FR EZ	25	8A-AR6-011-010		FOOT, AAR
6	8A-AR6-019-010		REFLECTOR, POWER	26	8A-AR6-003-010		PANEL, SIDE R
7	8A-AR6-005-010		KEY, POWER	A	87-067-579-010		TAPPING SCREW, BVT2+3-8
8	8A-AR6-013-010		LENS, REMCON	B	88-AR1-217-010		S-SCREW, BPT2+3-8
9	8A-AR6-007-010		KEY, SURROUND	C	87-067-703-010		TAPPING SCREW, BVT2+3-10
10	8A-AR6-008-010		KEY, FUN	D	87-067-584-010		TAPPING SCREW, BVT2+3-6
11	8A-AR6-009-010		KEY, TUN	E	87-743-095-410		TAPPING SCREW, UT2+3-8 (B)
12	8A-AR6-018-010		KEY, RDS	F	87-067-581-010		TAPPING SCREW, BVT2+3-15
13	8A-AR6-017-010		PLATE, REFLECTOR	G	87-NF4-224-010		S-SCREW, IT3B+3-8 CU
14	8A-AR6-202-010		GUIDE, LCD	H	87-067-130-010		W-F, 3.2-8.1 W/ADH
15	8A-AR6-037-010		PANEL, REAR EZSC				
16	87-A90-457-010		F-BEAD, 15-25-15 E251				
17	87-085-185-010		BUSHING, AC CORD (E)				
18	8A-MTM-649-010		AC CORD ASSY, EKH BLK				
19	8A-AR6-203-010		HLDR, PWB				
20	8A-AR6-002-010		PANEL, SIDE L				

## COLOR NAME TABLE

Basic color symbol	Color	Basic color symbol	Color	Basic color symbol	Color
B	Black	C	Cream	D	Orange
G	Green	H	Gray	L	Blue
LT	Transparent Blue	N	Gold	P	Pink
R	Red	S	Silver	ST	Titan Silver
T	Brown	V	Violet	W	White
WT	Transparent White	Y	Yellow	YT	Transparent Yellow
LM	Metallic Blue	LL	Light Blue	GT	Transparent Green
LD	Dark Blue	DT	Transparent Orange	GM	Metallic Green
YM	Metallic Yellow	DM	Metallic Orange	PT	Transparent Pink
LA	Aqua Blue	GL	Light Green	HT	Transparent Gray

## XD-DV50

## ELECTRICAL MAIN PARTS LIST

REF. NO.	PART NO.	KANRI NO.	DESCRIPTION	REF. NO.	PART NO.	KANRI NO.	DESCRIPTION
IC				C0005	87-A11-976-080		C-CAP,E 470-16 M 10.5L MV
				C0006	87-A12-416-080		C-CAP,E 100U-25 M 7.7L UD
	8Z-AV2-630-010		C-IC,L64021D	C0007	87-016-669-080		C-CAP,S 0.1-25 K B
	8Z-AV2-628-010		C-IC,HD6412350F20	C0008	87-A12-416-080		C-CAP,E 100U-25 M 7.7L UD
	8A-ZA7-804-010		C-IC,LC87F72C8A	C0009	87-016-669-080		C-CAP,S 0.1-25 K B
	8A-ZA7-803-010		C-IC,LC78660W				
	8A-ZA7-802-040		C-IC,LC324265AT-25DV	C0010	87-012-286-080		C-CAP,U 0.01-25 K B
				C0012	87-A11-282-080		C-CAP,S 1-16 K B
	8A-ZA7-801-040		C-IC,LA6556L-TE-L	C0015	87-A11-282-080		C-CAP,S 1-16 K B
	8A-ZA7-800-010		C-IC,LA9702W-MPB	C0016	87-010-831-080		C-CAP,U 0.1-16 Z F
	8A-ZA7-602-040		C-IC,HN58X2416FPI	C0017	87-A11-976-080		C-CAP,E 470-16 M 10.5L MV
	8A-AV6-632-010		IC,P-ROMAAV-6 (VER. 029)				
	8A-AV6-605-030		C-IC,UT611024LC-12	C0018	87-010-831-080		C-CAP,U 0.1-16 Z F
				C0019	87-A11-976-080		C-CAP,E 470-16 M 10.5L MV
	88-KT1-608-010		C-IC,LC75854W	C0020	87-A11-282-080		C-CAP,S 1-16 K B
	87-A21-764-040		C-IC,BA00ASFP	C0021	87-010-831-080		C-CAP,U 0.1-16 Z F
	87-A21-755-040		C-IC,SN74LV541APW	C0022	87-A11-976-080		C-CAP,E 470-16 M 10.5L MV
	87-A21-754-010		C-IC,MC44722AVFU				
	87-A21-697-040		C-IC,TC7SHU04F	C0023	87-010-831-080		C-CAP,U 0.1-16 Z F
				C0024	87-A11-976-080		C-CAP,E 470-16 M 10.5L MV
	87-A21-617-010		C-IC,HY57V161610DTC-8	C0026	87-010-831-080		C-CAP,U 0.1-16 Z F
	87-A21-613-040		C-IC,SN74LV04APW	C0027	87-A11-976-080		C-CAP,E 470-16 M 10.5L MV
	87-A21-362-040		C-IC,NJM2100M (TE2)	C0028	87-010-831-080		C-CAP,U 0.1-16 Z F
	87-A21-309-040		C-IC,HD74LV74A				
	87-A21-245-010		IC,RPM6938-V4	C0029	87-A11-976-080		C-CAP,E 470-16 M 10.5L MV
				C0100	87-012-274-080		C-CAP,U 1000P-50 K B
	87-A21-103-040		C-IC,MM1454XFBE	C0101	87-016-428-080		C-CAP,E 47-16 M 5.5L WX
	87-A21-032-080		C-IC,S-8520B28MC	C0102	87-010-831-080		C-CAP,U 0.1-16 Z F
	87-A20-957-040		C-IC,SN74LV245APW	C0103	87-010-831-080		C-CAP,U 0.1-16 Z F
	87-A20-925-040		C-IC,BA05FP				
	87-A20-905-040		C-IC,BA033FP	C0104	87-012-180-080		C-CAP,U 22P-50 J CH
				C0105	87-012-180-080		C-CAP,U 22P-50 J CH
	87-A20-689-080		C-IC,PCM1723	C0106	87-010-831-080		C-CAP,U 0.1-16 Z F
	87-A20-582-010		IC,GE1F31NJ	C0107	87-016-428-080		C-CAP,E 47-16 M 5.5L WX
	87-A20-185-040		C-IC,PST600DMT	C0108	87-010-831-080		C-CAP,U 0.1-16 Z F
	87-A20-080-040		C-IC,TC74HC14AF				
	87-017-917-080		C-IC,BU4066BCF	C0109	87-016-428-080		C-CAP,E 47-16 M 5.5L WX
				C0110	87-010-831-080		C-CAP,U 0.1-16 Z F
	87-017-750-080		C-IC,MM1041XM	C0111	87-012-195-080		C-CAP,U 100P-50 J CH
	87-017-585-080		C-IC,NJM4580E	C0112	87-010-831-080		C-CAP,U 0.1-16 Z F
	87-017-453-080		C-IC,NJM2267M	C0113	87-010-848-080		C-CAP,E 10-16 M 5.5L MV
	87-017-027-040		C-IC,TC7W08F				
	87-001-551-080		C-IC,TC7S08F	C0114	87-010-848-080		C-CAP,E 10-16 M 5.5L MV
				C0115	87-010-831-080		C-CAP,U 0.1-16 Z F
				C0116	87-012-172-080		C-CAP,U 10P-50 D CH
				C0117	87-012-172-080		C-CAP,U 10P-50 D CH
				C0118	87-012-172-080		C-CAP,U 10P-50 D CH
TRANSISTOR							
	89-342-132-080		C-TR,2SC4213B				
	89-341-165-080		C-TR,2SC4116GR	C0119	87-012-172-080		C-CAP,U 10P-50 D CH
	89-333-265-040		C-TR,2SC3326A	C0120	87-012-172-080		C-CAP,U 10P-50 D CH
	89-324-123-080		C-TR,2SC2412KS	C0121	87-012-172-080		C-CAP,U 10P-50 D CH
	89-211-323-080		C-TR,2SB1132R	C0122	87-012-172-080		C-CAP,U 10P-50 D CH
				C0123	87-012-172-080		C-CAP,U 10P-50 D CH
	89-115-864-080		C-TR,2SA1586Y				
	89-110-372-080		C-TR,2SA1037K (R)	C0124	87-012-172-080		C-CAP,U 10P-50 D CH
	87-A30-516-040		C-FET,3LN01C-TB	C0125	87-012-172-080		C-CAP,U 10P-50 D CH
	87-A30-382-040		C-FET,FTS1002	C0126	87-012-286-080		C-CAP,U 0.01-25 K B
	87-026-342-080		C-TR,DTC144EU	C0127	87-012-286-080		C-CAP,U 0.01-25 K B
				C0128	87-012-286-080		C-CAP,U 0.01-25 K B
	87-026-227-080		C-TR,DTA114EK				
	87-026-211-080		C-TR,DTA144EK	C0129	87-012-286-080		C-CAP,U 0.01-25 K B
	87-026-210-080		C-TR,DTC144EK	C0130	87-012-286-080		C-CAP,U 0.01-25 K B
				C0102	87-010-831-080		C-CAP,U 0.1-16 Z F
				C0202	87-A11-031-080		C-CAP,E 100-16 M WX
				C0203	87-010-831-080		C-CAP,U 0.1-16 Z F
DIODE							
	87-A40-797-040		C-DIODE,SBE001	C0205	87-010-831-080		C-CAP,U 0.1-16 Z F
	87-017-990-080		C-DIODE,U2FWJ44N	C0206	87-A11-031-080		C-CAP,E 100-16 M WX
	87-017-779-080		C-DIODE,1SS355	C0208	87-016-430-080		C-CAP,E 100-6.3 M 5.5L WX
	87-001-166-080		C-DIODE,1SS301	C0209	87-016-427-080		C-CAP,E 47-6.3 M 5.5L WX
	87-001-165-080		C-DIODE,1SS300	C0112	87-010-831-080		C-CAP,U 0.1-16 Z F
				C0217	87-010-831-080		C-CAP,U 0.1-16 Z F
				C0218	87-010-831-080		C-CAP,U 0.1-16 Z F
				C0219	87-A12-344-080		C-CAP,E 100-6.3 VC PX
				C0220	87-012-274-080		C-CAP,U 1000P-50 K B
MAIN C.B				C0221	87-012-274-080		C-CAP,U 1000P-50 K B
C0002	87-016-669-080		C-CAP,S 0.1-25 K B				
C0003	87-010-831-080		C-CAP,U 0.1-16 Z F				



REF. NO.	PART NO.	KANRI NO.	DESCRIPTION	REF. NO.	PART NO.	KANRI NO.	DESCRIPTION
C0222	87-010-831-080		C-CAP,U 0.1-16 Z F	C0342	87-012-180-080		C-CAP,U 22P-50 J CH
C0224	87-012-277-080		C-CAP,U 1800P-50 K B GRM	C0343	87-012-270-080		C-CAP,U 470P-50 K B
C0225	87-012-274-080		C-CAP,U 1000P-50 K B	C0344	87-012-195-080		C-CAP,U 100P-50 J CH
C0226	87-012-274-080		C-CAP,U 1000P-50 K B	C0345	87-012-197-080		C-CAP,U 150P-50 J CH
C0227	87-012-274-080		C-CAP,U 1000P-50 K B	C0346	87-012-196-080		C-CAP,U 120P-50 J CH
C0228	87-012-274-080		C-CAP,U 1000P-50 K B	C0347	87-012-165-080		C-CAP,U 3P-50 C CH
C0229	87-012-274-080		C-CAP,U 1000P-50 K B	C0348	87-010-831-080		C-CAP,U 0.1-16 Z F
C0231	87-012-274-080		C-CAP,U 1000P-50 K B	C0349	87-010-843-080		C-CAP,E 1-50 M 5.5L MV
C0232	87-012-274-080		C-CAP,U 1000P-50 K B	C0350	87-010-831-080		C-CAP,U 0.1-16 Z F
C0233	87-010-831-080		C-CAP,U 0.1-16 Z F	C0351	87-010-831-080		C-CAP,U 0.1-16 Z F
C0234	87-010-831-080		C-CAP,U 0.1-16 Z F	C0352	87-016-427-080		C-CAP,E 47-6.3 M 5.5L WX
C0235	87-012-174-080		C-CAP,U 12P-50 J CH	C0353	87-016-427-080		C-CAP,E 47-6.3 M 5.5L WX
C0236	87-012-174-080		C-CAP,U 12P-50 J CH	C0354	87-012-164-080		C-CAP,U 2P-50 C CH
C0237	87-010-831-080		C-CAP,U 0.1-16 Z F	C0355	87-A11-031-080		C-CAP,E 100-16 M WX
C0238	87-010-829-080		C-CAP,U 0.047-16 Z F	C0356	87-012-176-080		C-CAP,U 15P-50 J CH
C0239	87-010-829-080		C-CAP,U 0.047-16 Z F	C0357	87-010-831-080		C-CAP,U 0.1-16 Z F
C0240	87-010-831-080		C-CAP,U 0.1-16 Z F	C0358	87-012-274-080		C-CAP,U 1000P-50 K B
C0241	87-010-831-080		C-CAP,U 0.1-16 Z F	C0359	87-012-274-080		C-CAP,U 1000P-50 K B
C0242	87-012-286-080		C-CAP,U 0.01-25 K B	C0400	87-010-831-080		C-CAP,U 0.1-16 Z F
C0243	87-012-197-080		C-CAP,U 150P-50 J CH	C0401	87-016-427-080		C-CAP,E 47-6.3 M 5.5L WX
C0244	87-010-831-080		C-CAP,U 0.1-16 Z F	C0402	87-010-831-080		C-CAP,U 0.1-16 Z F
C0245	87-010-831-080		C-CAP,U 0.1-16 Z F	C0403	87-010-831-080		C-CAP,U 0.1-16 Z F
C0246	87-010-831-080		C-CAP,U 0.1-16 Z F	C0404	87-A11-968-080		C-CAP,E 220-16 M UR
C0247	87-010-831-080		C-CAP,U 0.1-16 Z F	C0405	87-010-831-080		C-CAP,U 0.1-16 Z F
C0248	87-010-831-080		C-CAP,U 0.1-16 Z F	C0406	87-010-831-080		C-CAP,U 0.1-16 Z F
C0249	87-010-831-080		C-CAP,U 0.1-16 Z F	C0407	87-012-199-080		C-CAP,U 220P-50 J CH
C0250	87-010-831-080		C-CAP,U 0.1-16 Z F	C0408	87-012-199-080		C-CAP,U 220P-50 J CH
C0251	87-010-831-080		C-CAP,U 0.1-16 Z F	C0409	87-012-199-080		C-CAP,U 220P-50 J CH
C0252	87-010-831-080		C-CAP,U 0.1-16 Z F	C0410	87-012-199-080		C-CAP,U 220P-50 J CH
C0253	87-010-831-080		C-CAP,U 0.1-16 Z F	C0424	87-010-848-080		C-CAP,E 10-16 M 5.5L MV
C0254	87-010-831-080		C-CAP,U 0.1-16 Z F	C0425	87-010-831-080		C-CAP,U 0.1-16 Z F
C0255	87-010-831-080		C-CAP,U 0.1-16 Z F	C0426	87-010-831-080		C-CAP,U 0.1-16 Z F
C0256	87-012-282-080		C-CAP,U 4700P-50 K B	C0427	87-010-848-080		C-CAP,E 10-16 M 5.5L MV
C0257	87-016-427-080		C-CAP,E 47-6.3 M 5.5L WX	C0601	87-012-286-080		C-CAP,U 0.01-25 K B
C0259	87-016-427-080		C-CAP,E 47-6.3 M 5.5L WX	C0602	87-012-286-080		C-CAP,U 0.01-25 K B
C0260	87-012-286-080		C-CAP,U 0.01-25 K B	C0604	87-012-286-080		C-CAP,U 0.01-25 K B
C0261	87-012-286-080		C-CAP,U 0.01-25 K B	C0605	87-012-286-080		C-CAP,U 0.01-25 K B
C0300	87-016-427-080		C-CAP,E 47-6.3 M 5.5L WX	C0608	87-016-428-080		C-CAP,E 47-16 M 5.5L WX
C0301	87-016-427-080		C-CAP,E 47-6.3 M 5.5L WX	C0609	87-012-286-080		C-CAP,U 0.01-25 K B
C0302	87-010-831-080		C-CAP,U 0.1-16 Z F	C0612	87-012-286-080		C-CAP,U 0.01-25 K B
C0303	87-010-831-080		C-CAP,U 0.1-16 Z F	C0613	87-012-286-080		C-CAP,U 0.01-25 K B
C0304	87-012-274-080		C-CAP,U 1000P-50 K B	C0614	87-012-172-080		C-CAP,U 10P-50 D CH
C0305	87-016-428-080		C-CAP,E 47-16 M 5.5L WX	C0615	87-016-428-080		C-CAP,E 47-16 M 5.5L WX
C0307	87-012-274-080		C-CAP,U 1000P-50 K B	C0617	87-012-172-080		C-CAP,U 10P-50 D CH
C0308	87-016-428-080		C-CAP,E 47-16 M 5.5L WX	C0619	87-012-286-080		C-CAP,U 0.01-25 K B
C0311	87-010-831-080		C-CAP,U 0.1-16 Z F	C0620	87-012-286-080		C-CAP,U 0.01-25 K B
C0312	87-012-271-080		C-CAP,U 560P-50 K B	C0623	87-012-286-080		C-CAP,U 0.01-25 K B
C0313	87-012-271-080		C-CAP,U 560P-50 K B	C0624	87-012-286-080		C-CAP,U 0.01-25 K B
C0314	87-012-271-080		C-CAP,U 560P-50 K B	C0625	87-010-848-080		C-CAP,E 10-16 M 5.5L MV
C0315	87-012-271-080		C-CAP,U 560P-50 K B	C0626	87-012-286-080		C-CAP,U 0.01-25 K B
C0316	87-012-271-080		C-CAP,U 560P-50 K B	C0627	87-012-286-080		C-CAP,U 0.01-25 K B
C0317	87-012-282-080		C-CAP,U 4700P-50 K B	C0628	87-012-286-080		C-CAP,U 0.01-25 K B
C0318	87-012-271-080		C-CAP,U 560P-50 K B	C0630	87-010-848-080		C-CAP,E 10-16 M 5.5L MV
C0319	87-012-196-080		C-CAP,U 120P-50 J CH	C0632	87-010-848-080		C-CAP,E 10-16 M 5.5L MV
C0320	87-A11-031-080		C-CAP,E 100-16 M WX	C0634	87-012-286-080		C-CAP,U 0.01-25 K B
C0321	87-010-831-080		C-CAP,U 0.1-16 Z F	C0639	87-010-848-080		C-CAP,E 10-16 M 5.5L MV
C0322	87-012-196-080		C-CAP,U 120P-50 J CH	C0640	87-012-286-080		C-CAP,U 0.01-25 K B
C0323	87-010-831-080		C-CAP,U 0.1-16 Z F	C0641	87-012-286-080		C-CAP,U 0.01-25 K B
C0324	87-012-197-080		C-CAP,U 150P-50 J CH	C0642	87-012-286-080		C-CAP,U 0.01-25 K B
C0330	87-012-184-080		C-CAP,U 33P-50 J CH	C0643	87-010-197-080		C-CAP,S 0.01-25 K B C2012
C0332	87-012-197-080		C-CAP,U 150P-50 J CH	C0702	87-016-428-080		C-CAP,E 47-16 M 5.5L WX
C0333	87-012-184-080		C-CAP,U 33P-50 J CH	C0703	87-A11-031-080		C-CAP,E 100-16 M WX
C0334	87-012-191-080		C-CAP,U 68P-50 J CH	C0704	87-012-286-080		C-CAP,U 0.01-25 K B
C0335	87-012-199-080		C-CAP,U 220P-50 J CH	C0705	87-012-286-080		C-CAP,U 0.01-25 K B
C0336	87-012-197-080		C-CAP,U 150P-50 J CH	C0706	87-012-286-080		C-CAP,U 0.01-25 K B
C0337	87-012-188-080		C-CAP,U 47P-50 J CH	C0707	87-012-278-080		C-CAP,U 2200P-50 K B
C0338	87-012-174-080		C-CAP,U 12P-50 J CH	C0708	87-012-286-080		C-CAP,U 0.01-25 K B
C0339	87-012-195-080		C-CAP,U 100P-50 J CH	C0709	87-012-286-080		C-CAP,U 0.01-25 K B
C0340	87-016-428-080		C-CAP,E 47-16 M 5.5L WX	C0710	87-016-428-080		C-CAP,E 47-16 M 5.5L WX
C0341	87-012-193-080		C-CAP,U 82P-50 J CH	C0711	87-012-286-080		C-CAP,U 0.01-25 K B

REF. NO.	PART NO.	KANRI NO.	DESCRIPTION	REF. NO.	PART NO.	KANRI NO.	DESCRIPTION
C0712	87-012-286-080		C-CAP,U 0.01-25 K B	C0838	87-012-174-080		C-CAP,U 12P-50 J CH
C0713	87-012-286-080		C-CAP,U 0.01-25 K B	C0839	87-012-178-080		C-CAP,U 18P-50 J CH
C0714	87-012-286-080		C-CAP,U 0.01-25 K B	C0844	87-012-168-080		C-CAP,U 6P-50 D CH
C0715	87-012-286-080		C-CAP,U 0.01-25 K B	C0950	87-012-286-080		C-CAP,U 0.01-25 K B
C0716	87-012-286-080		C-CAP,U 0.01-25 K B	C0951	87-010-848-080		C-CAP,E 10-16 M 5.5L MV
C0717	87-012-286-080		C-CAP,U 0.01-25 K B	C0952	87-010-846-080		C-CAP,E 4.7-35 M 5.5L MV
C0718	87-012-286-080		C-CAP,U 0.01-25 K B	C0953	87-A11-974-080		C-CAP,E 22-16 M 5.5L MV
C0719	87-012-286-080		C-CAP,U 0.01-25 K B	C0954	87-A11-031-080		C-CAP,E 100-16 M WX
C0720	87-012-286-080		C-CAP,U 0.01-25 K B	C0955	87-012-286-080		C-CAP,U 0.01-25 K B
C0721	87-012-286-080		C-CAP,U 0.01-25 K B	C0956	87-010-846-080		C-CAP,E 4.7-35 M 5.5L MV
C0722	87-012-286-080		C-CAP,U 0.01-25 K B	C0957	87-A11-974-080		C-CAP,E 22-16 M 5.5L MV
C0723	87-012-286-080		C-CAP,U 0.01-25 K B	C0958	87-A11-031-080		C-CAP,E 100-16 M WX
C0724	87-012-286-080		C-CAP,U 0.01-25 K B	C0959	87-012-286-080		C-CAP,U 0.01-25 K B
C0725	87-012-170-080		C-CAP,U 8P-50 D CH	C0960	87-012-286-080		C-CAP,U 0.01-25 K B
C0726	87-012-196-080		C-CAP,U 120P-50 J CH	C0961	87-010-831-080		C-CAP,U 0.1-16 Z F
C0731	87-010-848-080		C-CAP,E 10-16 M 5.5L MV	CN0100	87-A61-476-080		C-CONN,10P V WHT BM10B-SRSS-TB
C0732	87-012-286-080		C-CAP,U 0.01-25 K B	CN0300	87-A61-459-080		C-CONN,33P H XF2H-3315-1
C0733	87-012-196-080		C-CAP,U 120P-50 J CH	CN0402	87-A61-337-080		C-CONN,9P V WHT PH-SM3-TB
C0734	87-012-170-080		C-CAP,U 8P-50 D CH	CN0600	87-009-984-080		C-CONN,2P V WHT ZR
C0735	87-012-286-080		C-CAP,U 0.01-25 K B	CN0601	87-A60-777-010		CONN,14P B TMC-D(P)
C0736	87-010-848-080		C-CAP,E 10-16 M 5.5L MV	CNA0402	8A-ZGD-607-010		CONN ASSY,9P PH
C0737	87-010-848-080		C-CAP,E 10-16 M 5.5L MV	CNA0601	8A-AV6-618-010		CONN ASSY,2P V WHT LID U (CHIN
C0738	87-012-196-080		C-CAP,U 120P-50 J CH	FB0001	87-A91-720-080		C-F-BEAD, FBMJ3216HS800-T
C0741	87-010-831-080		C-CAP,U 0.1-16 Z F	FB0002	87-A91-720-080		C-F-BEAD, FBMJ3216HS800-T
C0744	87-010-831-080		C-CAP,U 0.1-16 Z F	FB0003	87-A91-720-080		C-F-BEAD, FBMJ3216HS800-T
C0745	87-010-831-080		C-CAP,U 0.1-16 Z F	FB0005	87-A91-720-080		C-F-BEAD, FBMJ3216HS800-T
C0759	87-010-848-080		C-CAP,E 10-16 M 5.5L MV	FB0006	87-A91-720-080		C-F-BEAD, FBMJ3216HS800-T
C0760	87-010-848-080		C-CAP,U 10-16 M 5.5L MV	FB0007	87-A91-720-080		C-F-BEAD, FBMJ3216HS800-T
C0771	87-012-278-080		C-CAP,U 2200P-50 K B	FB0008	87-A91-720-080		C-F-BEAD, FBMJ3216HS800-T
C0772	87-012-278-080		C-CAP,U 2200P-50 K B	FB0201	87-A91-720-080		C-F-BEAD, FBMJ3216HS800-T
C0773	87-012-279-080		C-CAP,U 2700P-50 K B GRM	FB0731	87-A91-480-080		C-F-BEAD, BK1608 HS121
C0774	87-012-279-080		C-CAP,U 2700P-50 K B GRM	FB0737	87-A91-480-080		C-F-BEAD, BK1608 HS121
C0775	87-012-267-080		C-CAP,U 270P-50 K B GRM	FB0739	87-A91-480-080		C-F-BEAD, BK1608 HS121
C0776	87-012-267-080		C-CAP,U 270P-50 K B GRM	FFC0001	8A-AV6-607-010		FLEX-PWB,33P RF
C0777	87-010-458-080		C-CAP,E 2.2-50 M MV	J0001	87-A61-165-010		JACK,DC 4.75 BLK 10.5
C0778	87-010-458-080		C-CAP,E 2.2-50 M MV	J0606	87-A61-145-010		C-SOCKET,IC 2-44P IC179-44600
C0779	87-A11-974-080		C-CAP,E 22-16 M 5.5L MV	J0950	87-A60-127-010		JACK,Y/CYRF51-5503
C0780	87-A11-974-080		C-CAP,E 22-16 M 5.5L MV	J0951	87-A61-473-010		JACK,PIN 3P WHT YKC21-5816
C0781	87-012-186-080		C-CAP,U 39P-50 J CH	L0003	87-A50-545-080		C-COIL,47UH-D124C
C0782	87-012-186-080		C-CAP,U 39P-50 J CH	L0004	84-HD1-620-080		C-COIL, 22UH M D75C
C0783	87-010-848-080		C-CAP,E 10-16 M 5.5L MV	L0005	87-A50-395-080		C-COIL,100UHD73C-636CY
C0784	87-010-831-080		C-CAP,U 0.1-16 Z F	L0006	87-A50-395-080		C-COIL,100UHD73C-636CY
C0785	87-010-831-080		C-CAP,U 0.1-16 Z F	L0100	87-A50-667-080		C-COIL, 1.0UH K FLC32
C0786	87-010-848-080		C-CAP,E 10-16 M 5.5L MV	L0201	87-A50-395-080		C-COIL,100UHD73C-636CY
C0787	87-010-831-080		C-CAP,U 0.1-16 Z F	L0202	87-A91-720-080		C-F-BEAD, FBMJ3216HS800-T
C0788	87-010-831-080		C-CAP,U 0.1-16 Z F	L0203	87-A50-668-080		C-COIL, 2.2UH K FLC32
C0789	87-010-848-080		C-CAP,E 10-16 M 5.5L MV	L0300	87-A50-395-080		C-COIL,100UHD73C-636CY
C0790	87-010-848-080		C-CAP,E 10-16 M 5.5L MV	L0301	87-005-811-080		C-COIL, 10UH FLC32
C0791	87-012-195-080		C-CAP,U 100P-50 J CH	L0302	87-005-811-080		C-COIL, 10UH FLC32
C0792	87-016-428-080		C-CAP,E 47-16 M 5.5L WX	L0400	87-A50-667-080		C-COIL, 1.0UH K FLC32
C0793	87-012-286-080		C-CAP,U 0.01-25 K B	L0600	87-A50-667-080		C-COIL, 1.0UH K FLC32
C0794	87-012-286-080		C-CAP,U 0.01-25 K B	L0601	87-A50-667-080		C-COIL, 1.0UH K FLC32
C0795	87-A11-974-080		C-CAP,E 22-16 M 5.5L MV	L0602	87-A50-667-080		C-COIL, 1.0UH K FLC32
C0800	87-012-286-080		C-CAP,U 0.01-25 K B	L0603	87-A50-667-080		C-COIL, 1.0UH K FLC32
C0801	87-016-428-080		C-CAP,E 47-16 M 5.5L WX	L0700	87-A50-667-080		C-COIL, 1.0UH K FLC32
C0802	87-016-428-080		C-CAP,E 47-16 M 5.5L WX	L0701	87-A50-667-080		C-COIL, 1.0UH K FLC32
C0803	87-010-831-080		C-CAP,U 0.1-16 Z F	L0702	87-A50-668-080		C-COIL, 2.2UH K FLC32
C0804	87-010-831-080		C-CAP,U 0.1-16 Z F	L0704	87-A50-668-080		C-COIL, 2.2UH K FLC32
C0806	87-010-831-080		C-CAP,U 0.1-16 Z F	L0705	87-005-815-080		C-COIL, 22UH J FLC32
C0810	87-012-286-080		C-CAP,U 0.01-25 K B	L0800	87-A50-668-080		C-COIL, 2.2UH K FLC32
C0811	87-016-428-080		C-CAP,E 47-16 M 5.5L WX	L0801	87-005-815-080		C-COIL, 22UH J FLC32
C0812	87-012-286-080		C-CAP,U 0.01-25 K B	L0802	87-005-811-080		C-COIL, 10UH FLC32
C0817	87-010-848-080		C-CAP,E 10-16 M 5.5L MV	L0803	87-005-817-080		C-COIL, 33UH J FLC32
C0818	87-012-286-080		C-CAP,U 0.01-25 K B	L0805	87-005-816-080		C-COIL, 27UH J FLC32
C0819	87-012-186-080		C-CAP,U 39P-50 J CH	L0806	87-005-816-080		C-COIL, 27UH J FLC32
C0820	87-012-182-080		C-CAP,U 27P-50 J CH	L0810	87-005-816-080		C-COIL, 27UH J FLC32
C0834	87-012-184-080		C-CAP,U 33P-50 J CH	L0811	87-005-816-080		C-COIL, 27UH J FLC32
C0835	87-012-174-080		C-CAP,U 12P-50 J CH	L0950	87-005-815-080		C-COIL, 22UH J FLC32
C0836	87-012-178-080		C-CAP,U 18P-50 J CH	R0005	87-022-247-080		C-RES,U 68K-1/16W F
C0837	87-012-184-080		C-CAP,U 33P-50 J CH	R0006	87-022-284-080		C-RES,U 68K-1/16W F

REF. NO.	PART NO.	KANRI NO.	DESCRIPTION	REF. NO.	PART NO.	KANRI NO.	DESCRIPTION
R0012	87-022-284-080		C-RES,U 68K-1/16W F	LED0500	87-A41-095-010		LED,SELS5B20C ORG
R0013	87-022-285-080		C-RES,U 82K-1/16W F	LED0501	87-A41-095-010		LED,SELS5B20C ORG
R0020	87-022-241-080		C-RES,U 12K-1/16W F	S0500	87-A90-164-080		SW,TACT SKQNB(N)
R0021	87-022-223-080		C-RES,U 2.2K-1/16W F	S0501	87-A90-164-080		SW,TACT SKQNB(N)
S0950	87-A90-166-010		SW,SL SLD-12-500H	S0502	87-A90-164-080		SW,TACT SKQNB(N)
X0100	87-A70-284-080		C-VIB,XTAL 10MHZ HC-49/U03C	S0503	87-A90-164-080		SW,TACT SKQNB(N)
X0200	87-A70-283-080		C-VIB,XTAL 16.9344MHZ HC-49/U0	S0504	87-A90-164-080		SW,TACT SKQNB(N)
X0600	87-A70-194-080		C-VIB,XTAL 20MHZ HC-49/U03C	S0505	87-A90-164-080		SW,TACT SKQNB(N)
X0700	87-A70-195-080		C-VIB,XTAL 27MHZ HC-49/U03C	S0506	87-A90-164-080		SW,TACT SKQNB(N)
				S0507	87-A90-164-080		SW,TACT SKQNB(N)
FRONT C.B				S0508	87-A90-164-080		SW,TACT SKQNB(N)
C0500	87-010-831-080		C-CAP,U 0.1-16 Z F	S0509	87-A90-164-080		SW,TACT SKQNB(N)
C0501	87-010-831-080		C-CAP,U 0.1-16 Z F	S0510	87-A90-164-080		SW,TACT SKQNB(N)
C0502	87-012-272-080		C-CAP,U 680P-50 K B GRM	S0511	87-A90-164-080		SW,TACT SKQNB(N)
C0503	87-010-831-080		C-CAP,U 0.1-16 Z F	S0512	87-A90-164-080		SW,TACT SKQNB(N)
C0504	87-010-498-080		CAP,E 10-16 M 5L SRE	S0513	87-A90-164-080		SW,TACT SKQNB(N)
C0505	87-010-831-080		C-CAP,U 0.1-16 Z F	S0514	87-A90-164-080		SW,TACT SKQNB(N)
C0506	87-010-498-080		CAP,E 10-16 M 5L SRE	S0515	87-A90-164-080		SW,TACT SKQNB(N)
CN0500	87-A60-769-010		CONN,14P B TMC-D(X)				
L0500	87-005-184-080		COIL,1UH K EL0606				
LCD0500	8A-AV6-608-010		LCD,AAV-6				

- Regarding connectors, they are not stocked as they are not the initial order items.  
The connectors are available after they are supplied from connector manufacturers upon the order is received.

#### チップ抵抗部品コード/CHIP RESISTOR PART CODE

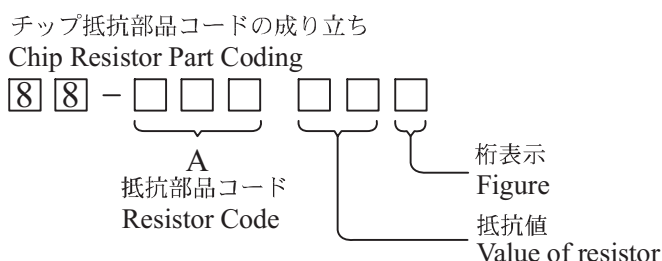

#### チップ抵抗 Chip resistor

容量 Wattage	種類 Type	許容誤差 Tolerance	記号 Symbol	寸法/Dimensions (mm)			抵抗コード : A Resistor Code : A	
				外形/Form	L	W		t
1/16W	1005	± 5%	CJ		1.0	0.5	0.35	104
1/16W	1608	± 5%	CJ		1.6	0.8	0.45	108
1/10W	2125	± 5%	CJ		2	1.25	0.45	118
1/8W	3216	± 5%	CJ		3.2	1.6	0.55	128

# TRANSISTOR ILLUSTRATION

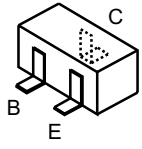

2SA1037  
2SA1586  
2SC2412  
2SC3326  
2SC4116  
2SC4213  
DTA114EK  
DTA144EK  
DTC144EK  
DTC144EU

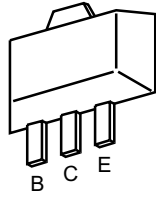

2SB1132

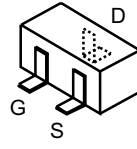

3LN01C

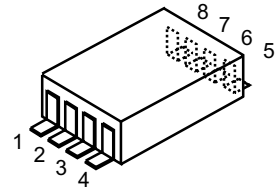

FTS1002

# 3 BLOCK DIAGRAM

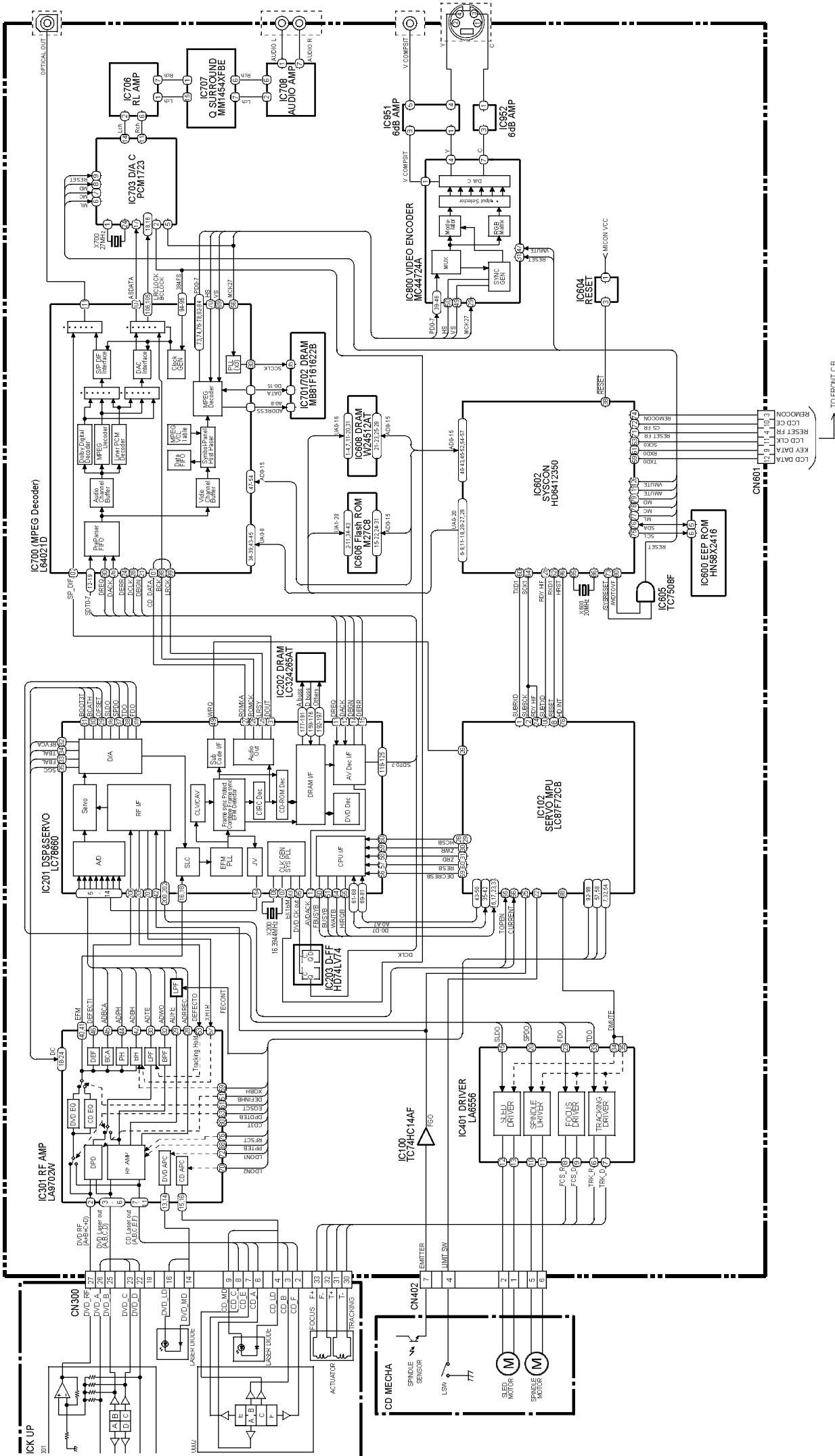

# MAIN C.B (BOTTOM VIEW)

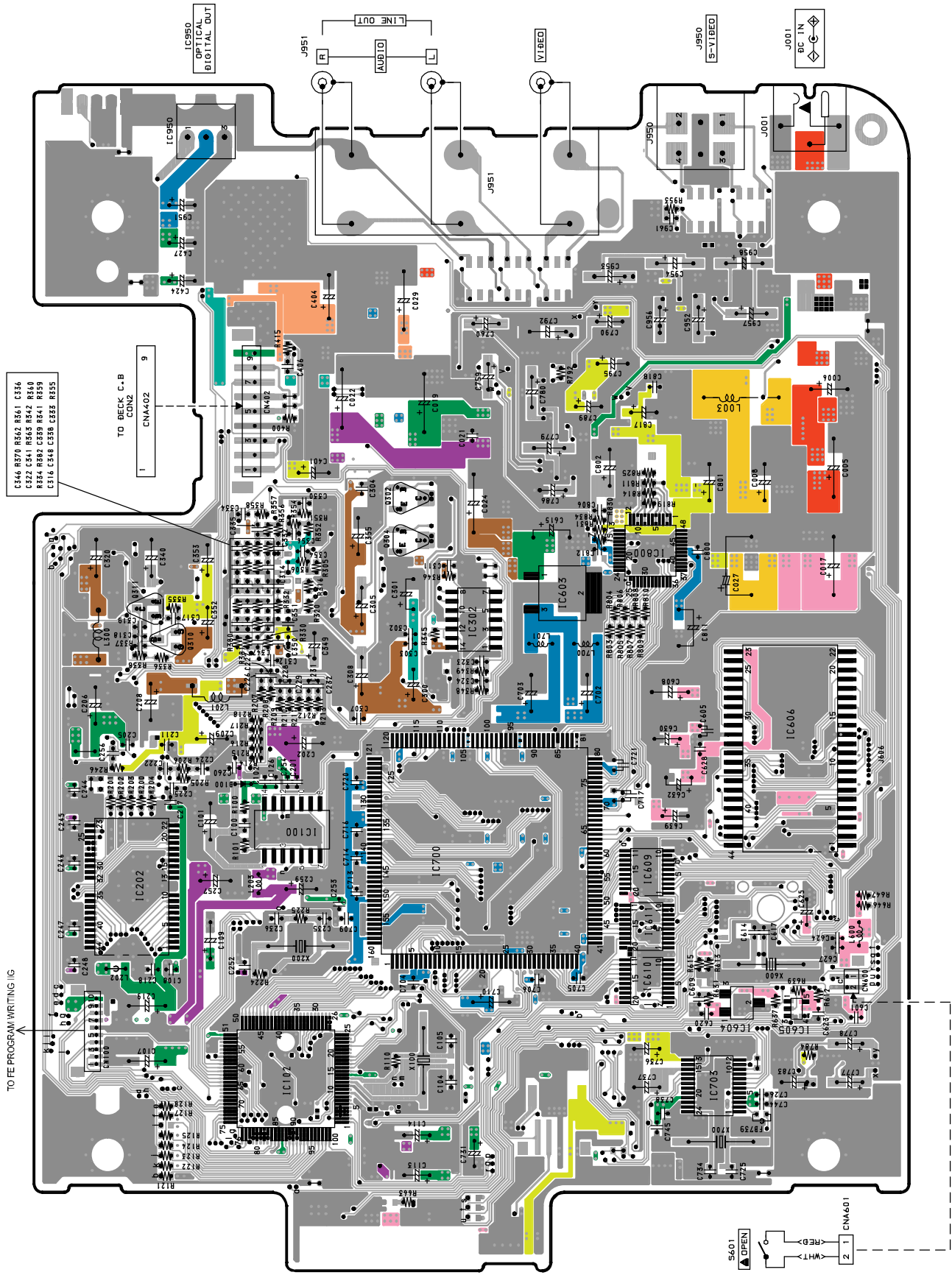



SCHEMATIC DIAGRAM - 1 (MAIN C.B -1/5)

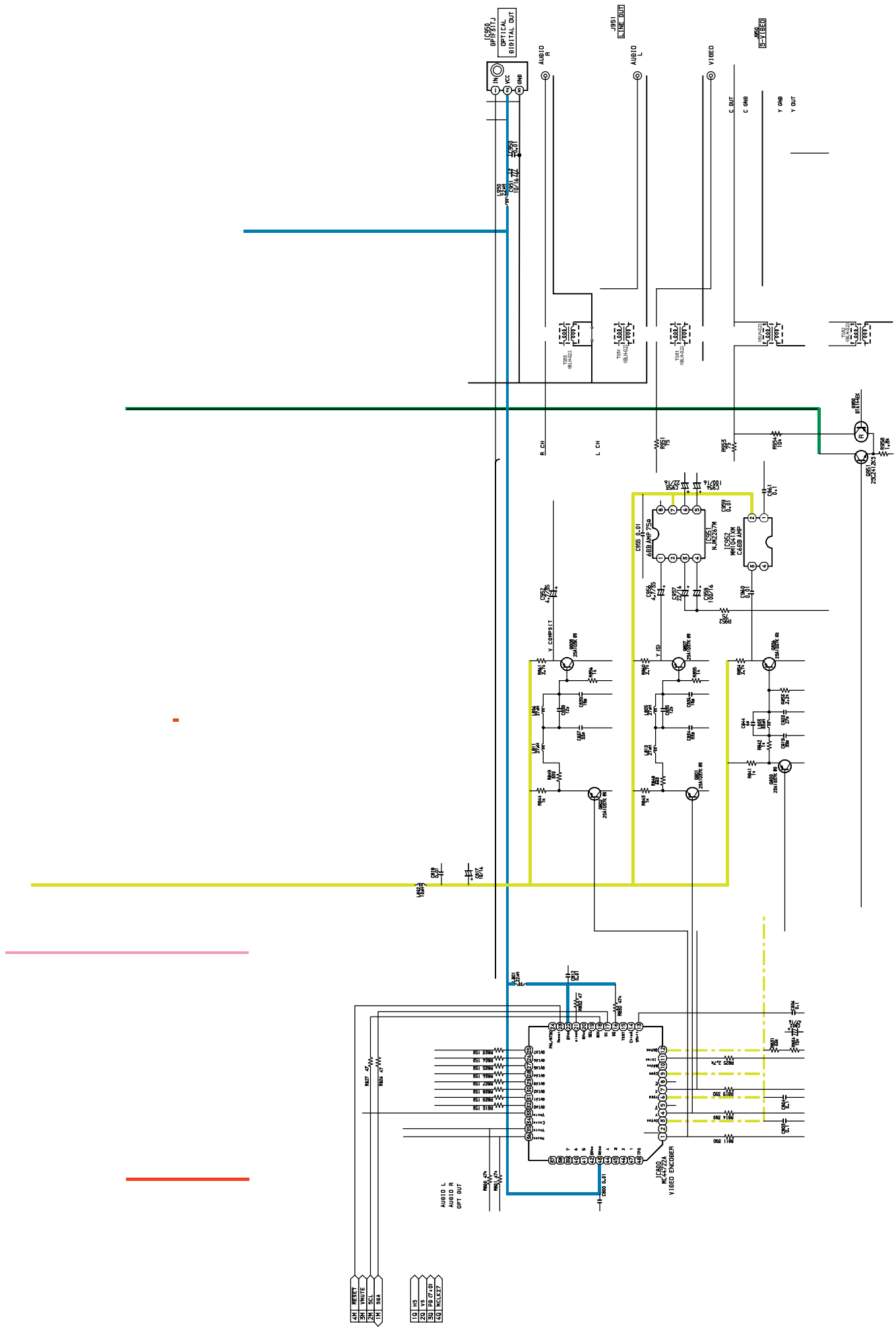

4H	HERBY
5H	WHITE
2H	5C1L
1H	5H4

  

10	1S
20	1S
30	1S
40	1S1227



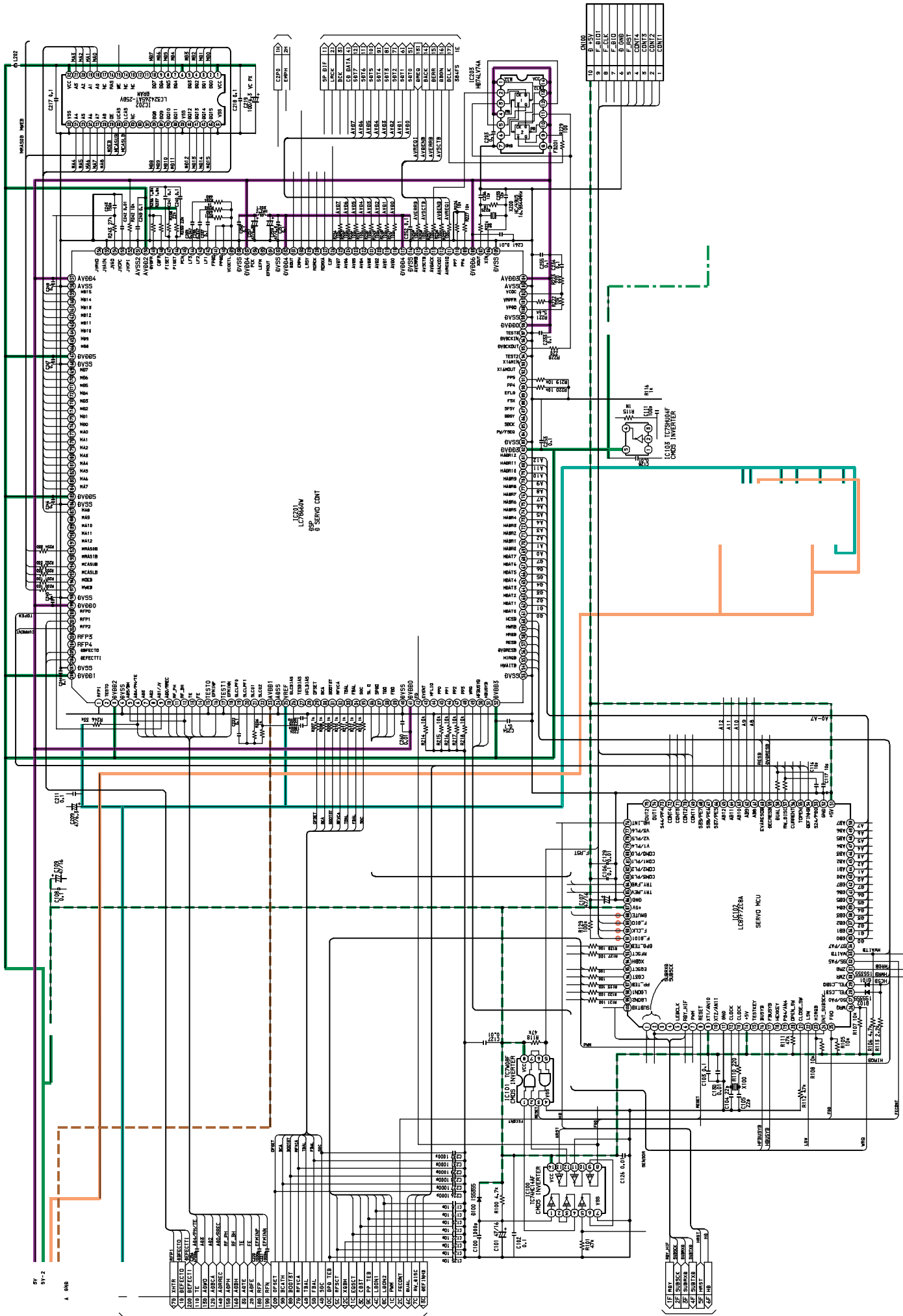

SCHEMATIC DIAGRAM - 3 (MAIN C.B -3/5)

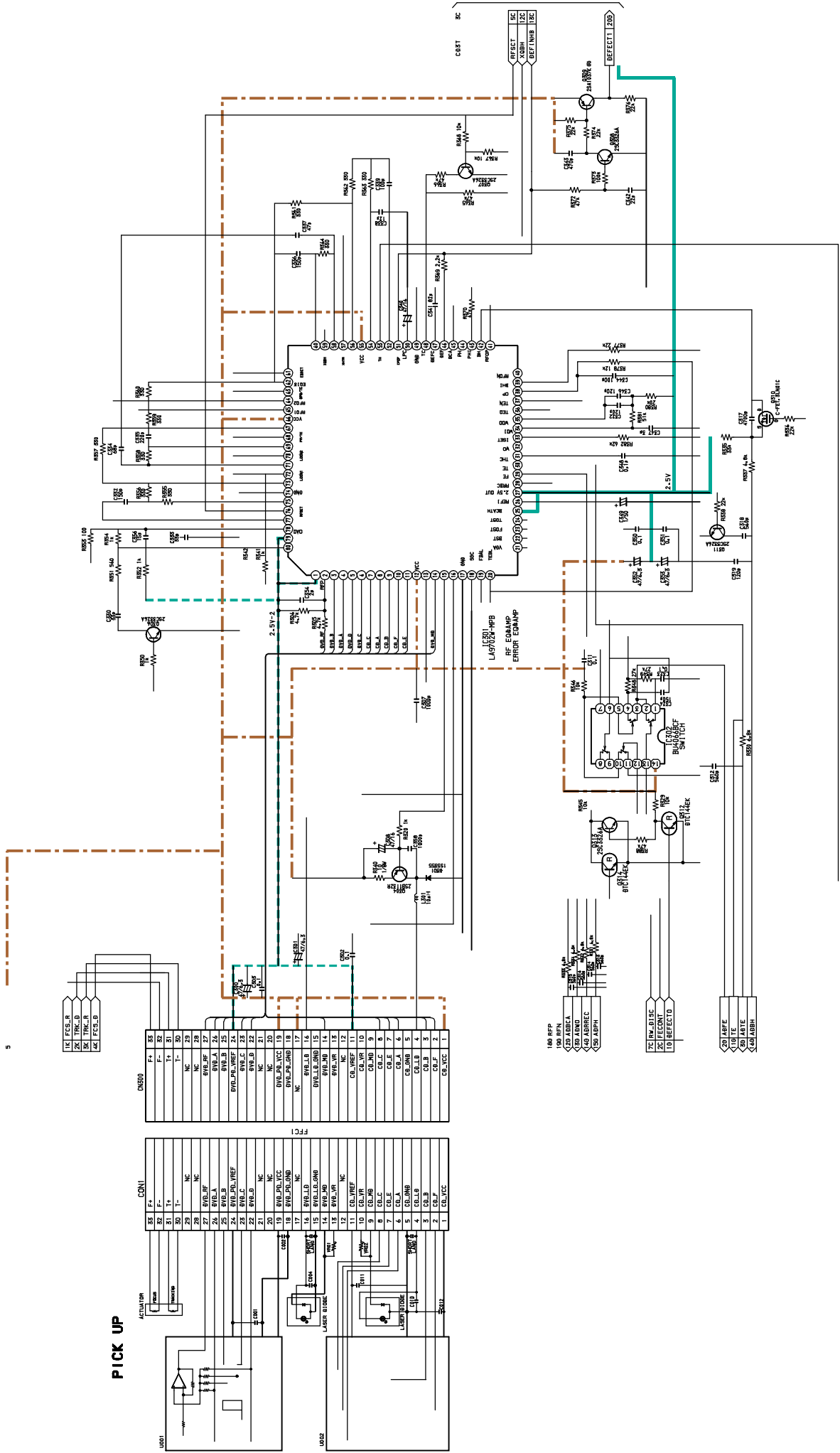

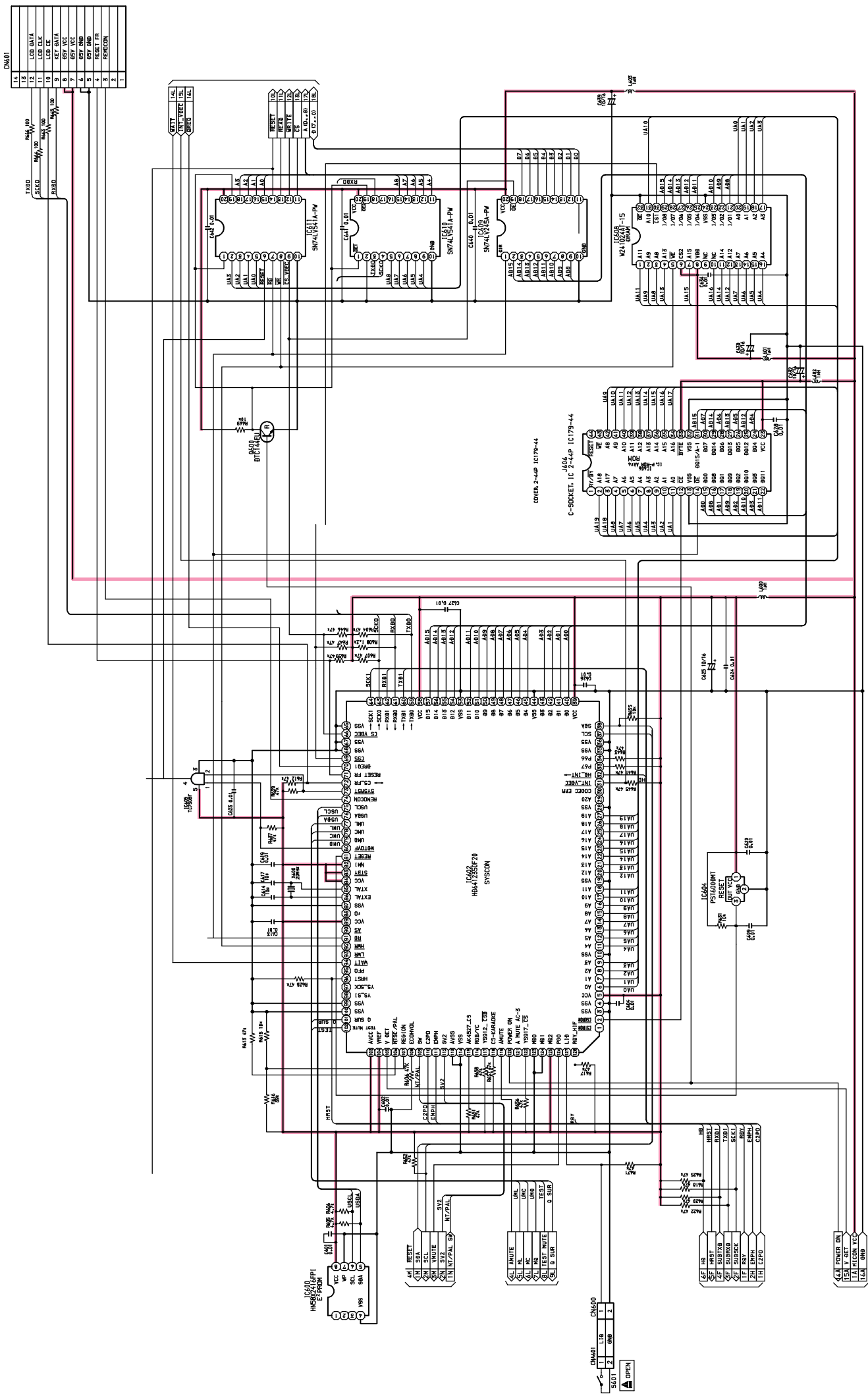

SCHEMATIC DIAGRAM - 5 (MAIN C.B.-5/5)

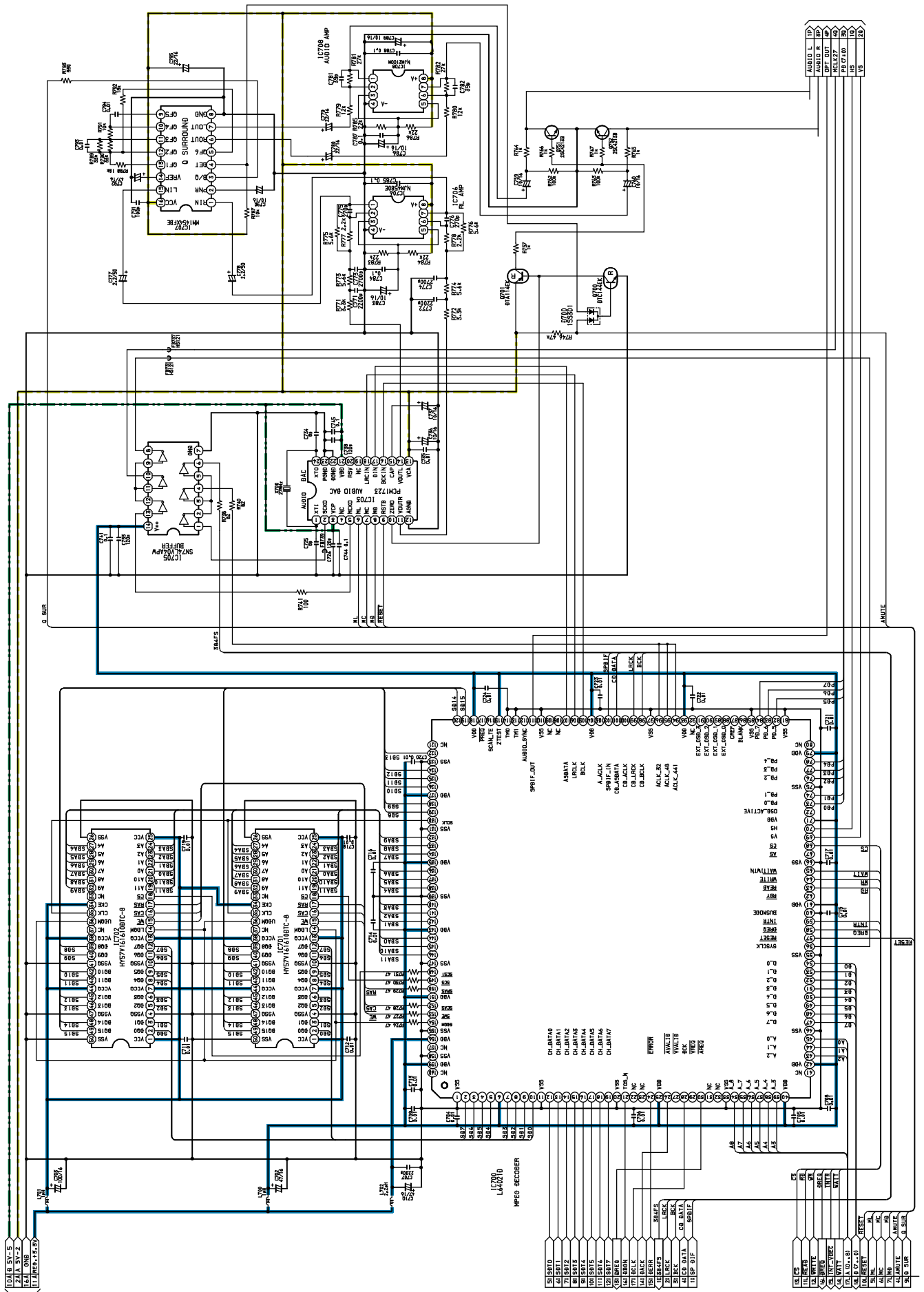

# FRONT C.B

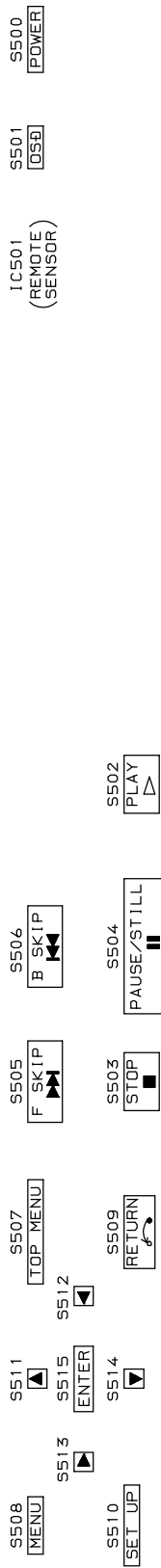
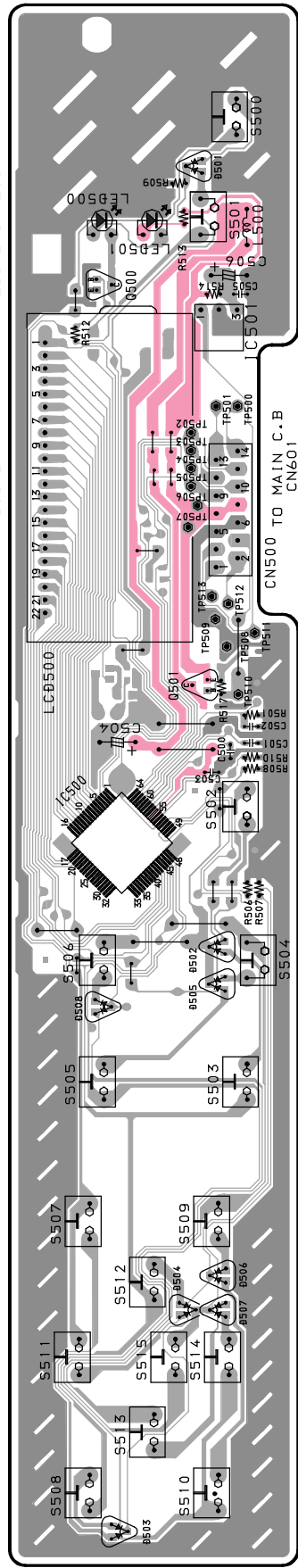

## DECK C. B

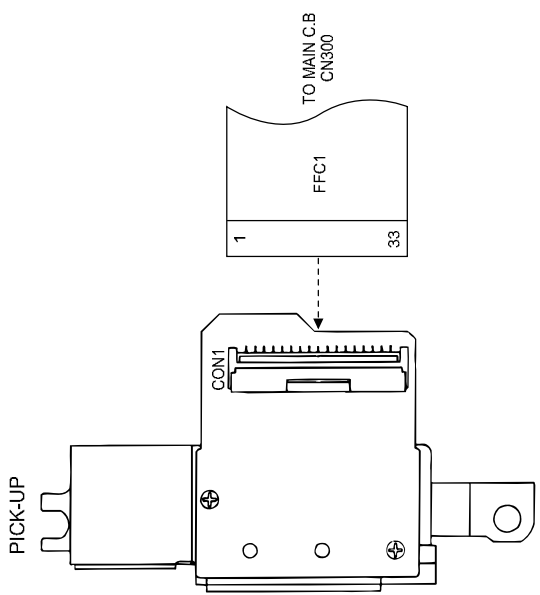
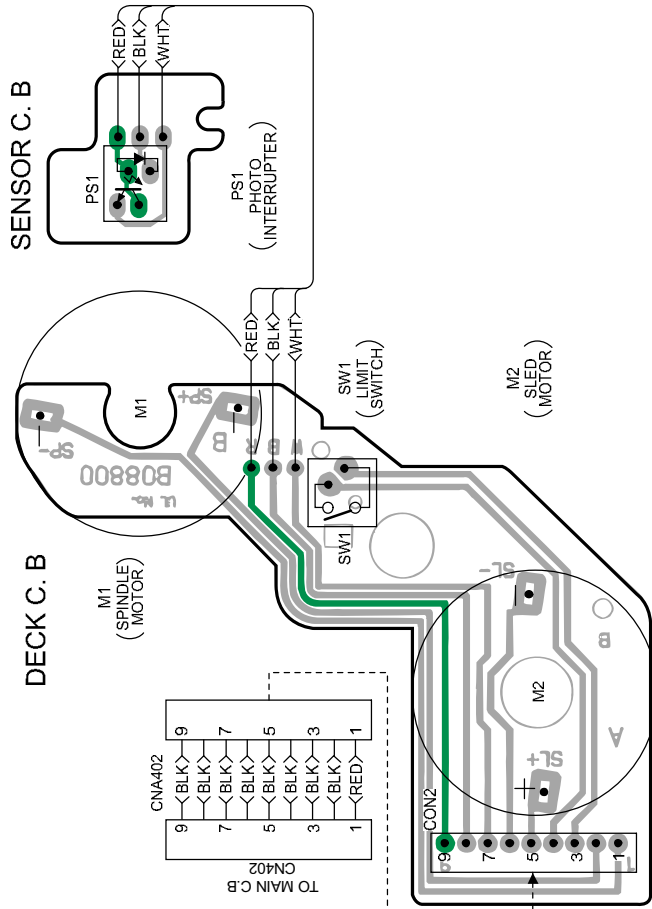

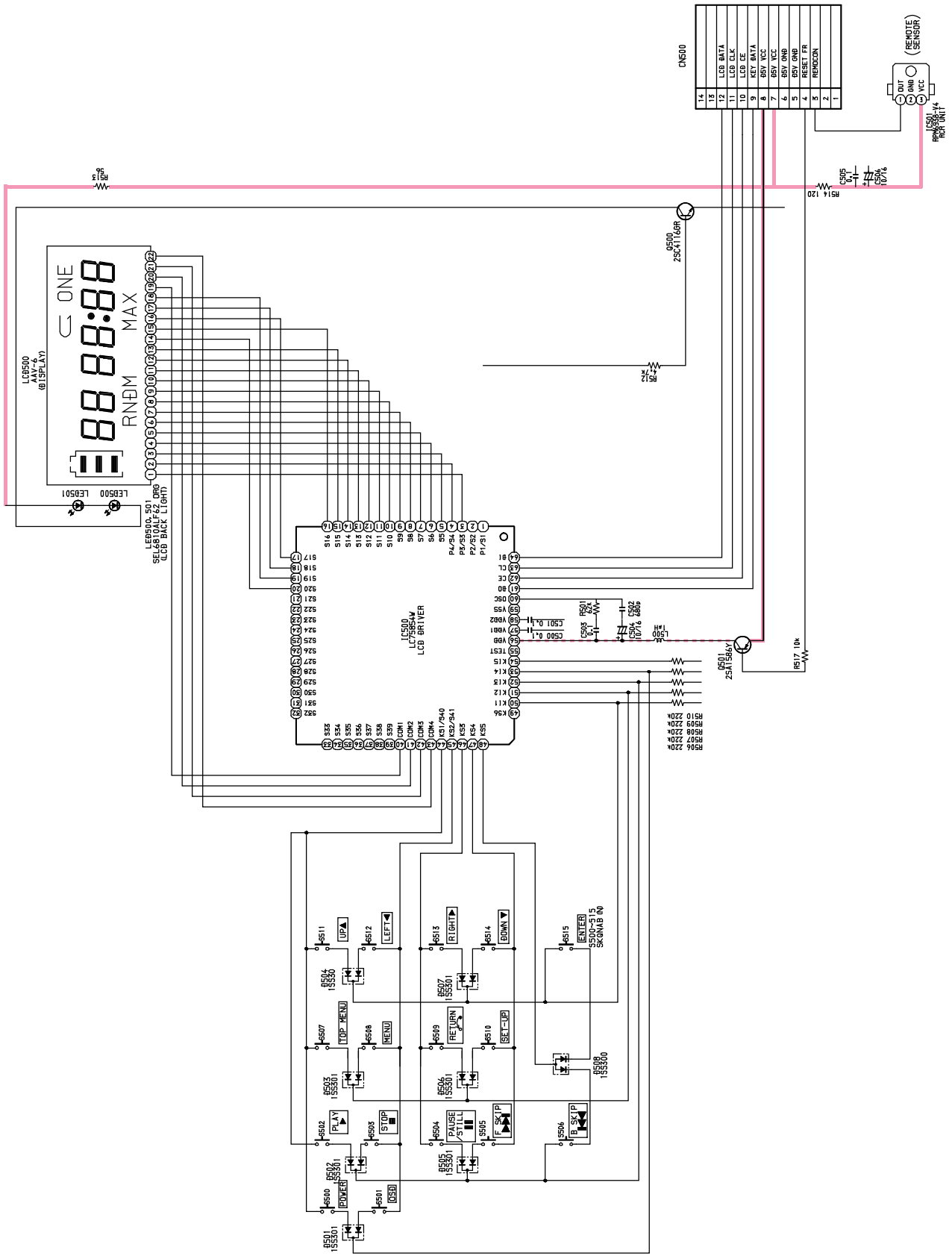

LCD DISPLAY

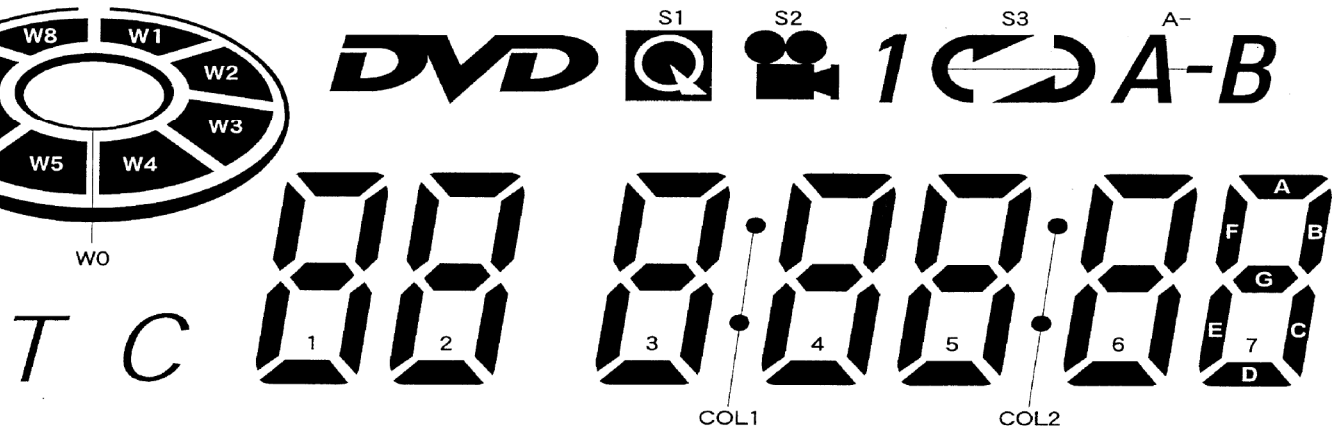
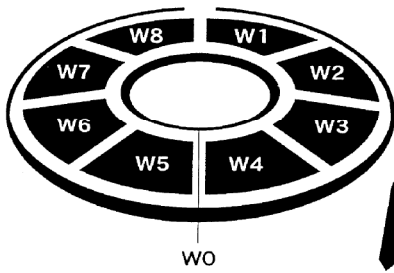
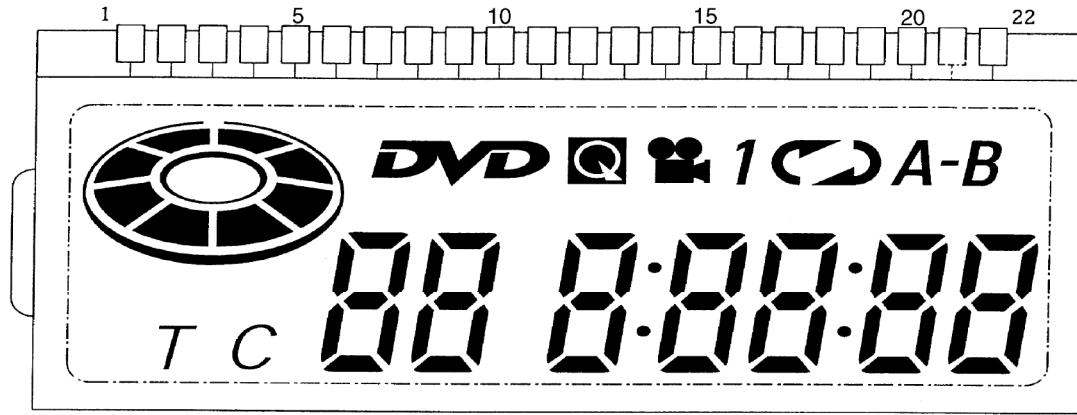

NO	COM1	COM2	COM3	COM4
1	W5	W6	W8	W7
2	W4	W3	W1	W2
3	W0	1F	1G	1E
4	1A	1B	1C	1D
5	DVD	2F	2G	2E
6	2A	2B	2C	2D
7	S1	3F	3G	3E
8	3A	3B	3C	3D
9	---	S2	COL1	C
10	---	4F	4G	4E
11	4A	4B	4C	4D
12	1	5F	5G	5E
13	5A	5B	5C	5D
14	---	S3	COL2	T
15	A-	6F	6G	6E
16	6A	6B	6C	6D
17	B	7F	7G	6E
18	7A	7B	7C	6D
19	COM1	---	---	---
20	---	COM2	---	---
21	---	---	COM3	---
22	---	---	---	COM4

# IC BLOCK DIAGRAM

IC, BA00ASFP

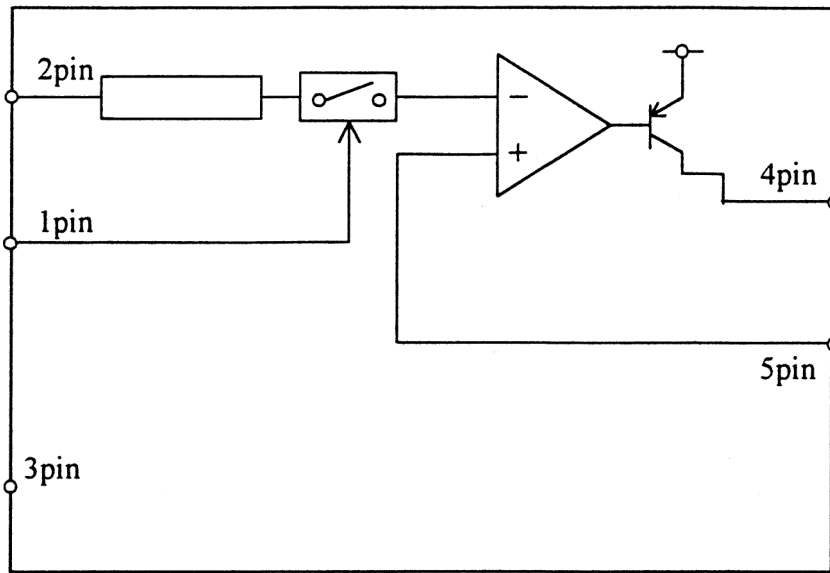

IC, SN74LV541APW

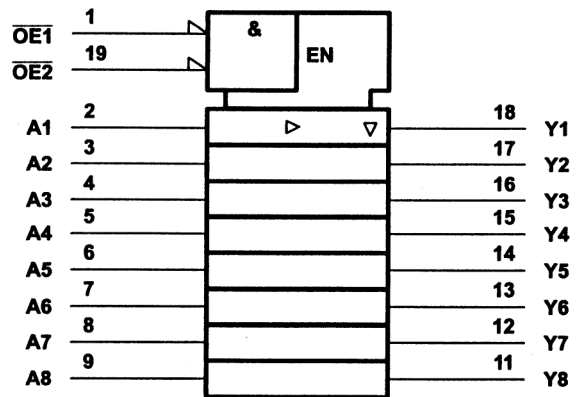
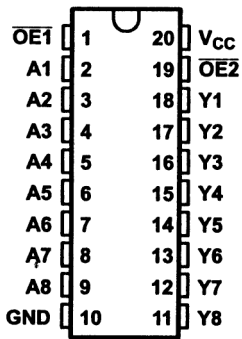

INPUTS			OUTPUT
OE1	OE2	A	Y
L	L	L	L
L	L	H	H
H	X	X	Z
X	H	X	Z

H: High level  
 L: Low level  
 X: Not designated  
 Z: High impedance condition

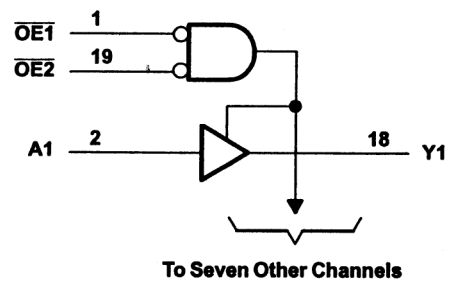



IC, NJM2267M

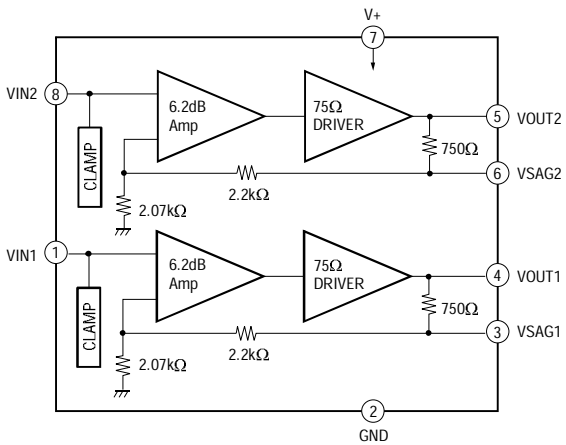

IC, MM1454XFBE

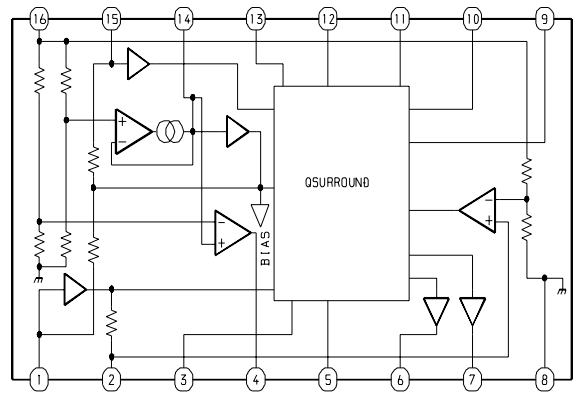

IC, LC75854W

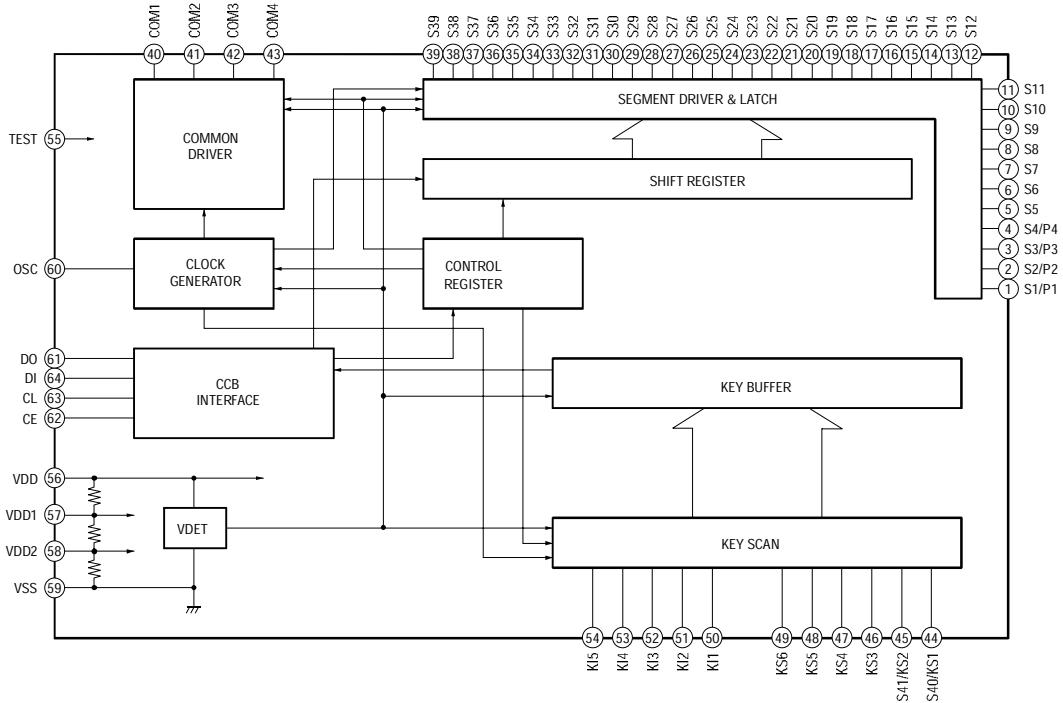

IC, NJM2100M

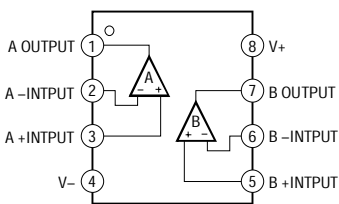

IC, NJM4580E

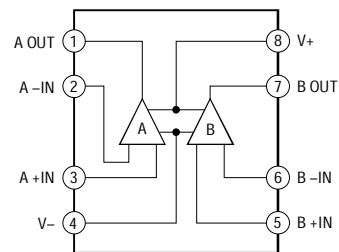

IC, LA6556L-TE-L

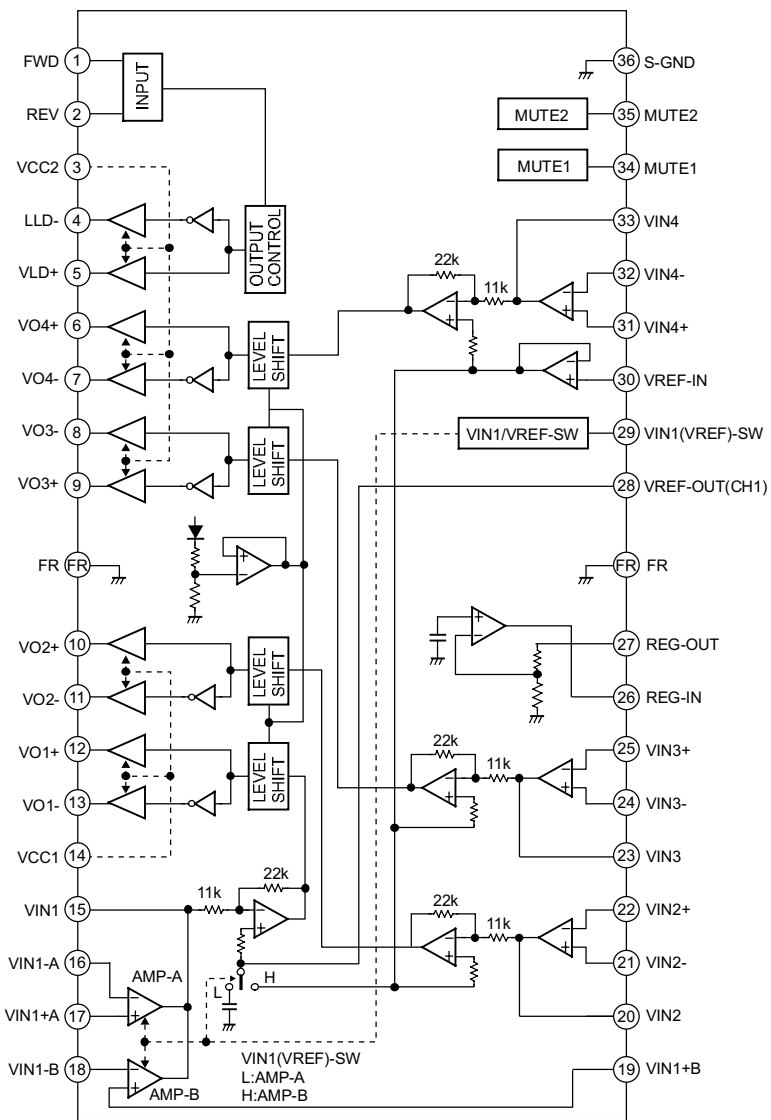

IC, MM1041XM

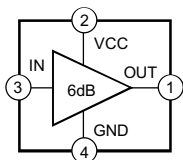

IC, TC74HC14AF

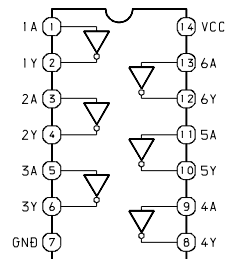

TRUTH TABLE

1A ~ 6A	1Y ~ 6Y
L	H
H	L

IC, PCM1723

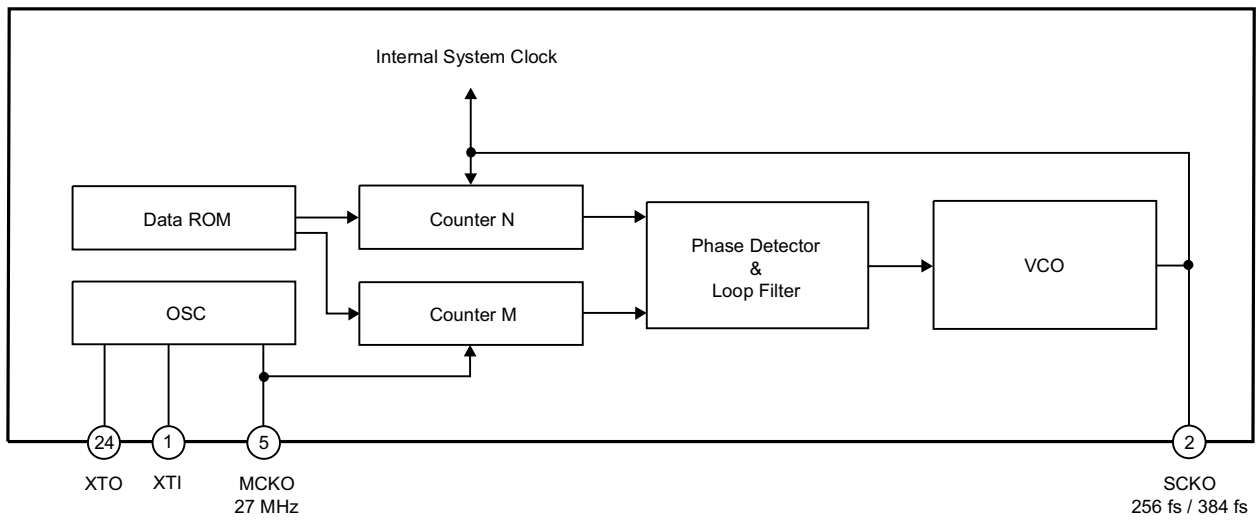

IC, S-8520B28MC

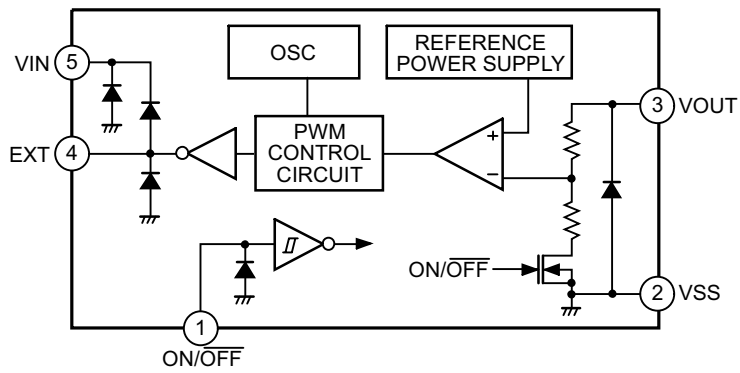

IC, SN74LV245APW

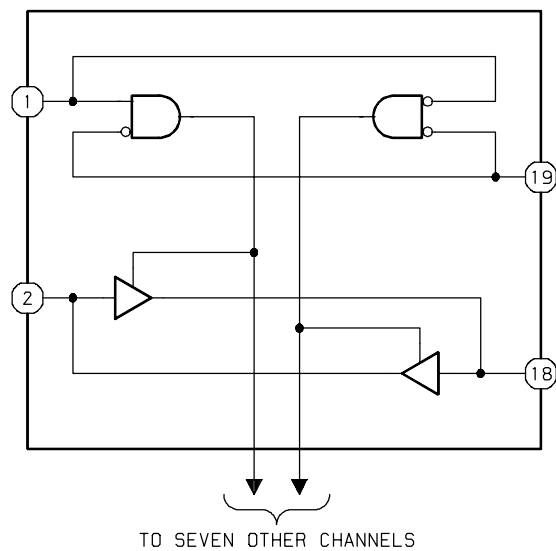

## IC DESCRIPTION

IC, MC44722AVFU

Pin No.	Pin Name	I/O	Description
1	CVBS/CB	O	Analog composite video signal or Cb signal output current drive (positive)
2	CVBS/CB	O	Analog composite video signal or Cb signal output current drive (negative)
3	CVBS/CBVDD		Power supply for CVBS/Cb DAC circuit
4	Y	O	Analog luminance signal output current drive (positive)
5	Y	O	Analog luminance signal output current drive (negative)
6	YVDD	–	Power supply for Y DAC circuit
7	C/CR	O	Analog signal output or Cr signal output drive (positive)
8	C/CR	O	Analog signal output or Cr signal output drive (negative)
9	CVDD	–	Power supply for C/Cr DAC circuit
10	DAVSS	–	Ground for DAC circuit
11	TBIAS	O	Reference current for the 3 DACs
12	DAVDD	–	Power supply for DAC current
13	VREF	–	Reference full scale voltage for the 3 DACs
14	CHIPA	I	12C chip address select (0 : 42(hex)/43(hex), 1 : IC(hex)/1D(hex))
15	TEST	I	TEST pin (Ground)
16	SO	O	If SPI mode, serial data output/If 12C mode, connect to ground
17	SDA/SI	I/O	Serial data input, open drain output. If SPI mode, serial data input.
18	SCL/SCK	I	Serial clock
19	SEL	I	Connect to ground. If SPI mode, this pin is chip select.
20	DVSS	–	Ground for digital circuit
21	CLOCK	I	27 MHz clock input
22	DVDD	–	Power supply for digital circuit
23	RESET	I	Reset signal (active Low)
24	PAL/NTSC	I	NTSC/PAL select. This pin active only reset time (NTSC: Low, PAL: High)
25 ~ 32	DVIA7 ~ 0	I	8-bit multiplexed Y/Cr/Cb 4:2:2 data (ITU-Rec656) input (DVIA), or multiplexed Y data (ITU-Rec656/601) input in 16-bit input mode (DVIA7: MSB)
33	VMUTE	I	Video mute on reset (0: normal, 1: mute), or test data input
34	C/FSYNC/VBI	I/O	Csync/frame sync output or external VBI information input
35	F/VSYNC	I/O	Frame sync or vertical sync input/output
36	HSYNC	I/O	Horizontal sync input/output
37	A/B SEL	I/O	Switch control for 8-bit X2 multiplexed Y/Cr/Cb 4:2:2 data (ITU-Rec656) input (DVIA) or (DVIB), or test data I/O
38 ~ 41	DVIB7 ~ 4	I/O	8-bit multiplexed 4:2:2 data (ITU-Rec656/601) input (2), or multiplexed Cr/Cb data (ITU-Rec656/601) input in 16-bit input mode (MSB DVIB 8), or test data I/O
42	DVSS	–	Ground for digital circuit
43	DVDD	–	Power supply for digital circuit
44 ~ 47	DVIB3 ~ 0	I/O	8-bit multiplexed 4:2:2 data (ITU-Rec656/601) input (DVIB), or multiplexed Cr/Cb data (ITU-Rec656/601) input in 16-bit input mode (LSB DVIB), or test data I/O
48	TP	I/O	for test (should be ground)

## IC, L64021D

Pin No.	Pin Name	I/O	Description
1	VSS	I	Ground.
2 ~ 5	SBD_7 ~ 4	I/O	SDRAM data bus 7 ~ 4.
6	VDD	I	Power (3.3V).
7 ~ 10	SBD_3 ~ 0	I/O	SDRAM data bus 3 ~ 0.
11	VSS	I	Ground.
12 ~ 19	CH_DATA_0 ~ 7	I	Channel data bus 0 ~ 7.
20	VSS	I	Ground.
21	TOS	I	Top of sector.
22, 23	NC	I	Not connected.
24	ERROR	I	Error.
25	VDD	I	Power (3.3V).
26	AVALID	I	Audio data valid.
27	VVALID	I	Video data valid.
28	DCK	I	Data clock.
29	VREQ	O	Video transfer request.
30	AREQ	O	Audio transfer request.
31, 32	NC	—	Not connected.
33	VSS	I	Ground.
34 ~ 39	A_8 ~ 3	I	Address 8 ~ 3.
40	VDD	I	Power (3.3V).
41	NC	—	Not connected.
42	VDD	I	Power (3.3V).
43 ~ 45	A_2 ~ 0	I	Address 2 ~ 0.
46	VSS	I	Ground.
47 ~ 54	D_7 ~ 0	I/O	Host data bus 7 ~ 0.
55	VSS	I	Ground.
56	SYSCLK	I	System clock.
57	RESET	I	Reset.
58	DREQ	O	DMA transfer request.
59	INTR	O	Interrupt.
60	BUSMODE	I	Busmode.
61	VDD	I	Power (3.3V).
62	RDY	O	Ready.
63	READ	I	Read indicator.
64	WRITE	I	Write indicator.
65	WAIT/WTN	I/O	Wait.
66	VSS	I	Ground.
67	NC	—	Not connected.
68	CS	I	Chip select.
69	VS	I	Vertical synchronization.
70	HS	I	Horizontal synchronization.

Pin No.	Pin Name	I/O	Description
71	VDD	I	Power (3.3V).
72	OSD_ACTIVE	O	On screen display active.
73, 74	PD_0, 1	O	Pixel data output bus 0, 1.
75	VSS	I	Ground.
76-78	PD_2-4	O	Pixel data output bus 2-4.
79	VDD	I	Power (3.3V).
80	NC	—	Not connected.
81	VSS	I	Ground.
82 ~ 84	PD_5 ~ 7	O	Pixel data output bus 5 ~ 7.
85	VSS	I	Ground.
86	BLANK	O	Blank (composite).
87	CREF	O	Chroma reference for pixel data.
88 ~ 91	EXT_OSD_0 ~ 3	I	External OSD palette selection bus 0 ~ 3.
92	NC	O	Not connected.
93	VDD	I	Power (3.3V).
94	ACLK_441	I	Audio input clock for 44.1kHz*N.
95	ACLK_48	I	Audio input clock for 48kHz*N.
96	ACLK_32	I	Audio input clock for 32kHz*N.
97	VSS	I	Ground.
98	CD_BCLK	I	CD-Serial DAC bit clock.
99	CD_LRCLK	I	CD-Left right clock.
100	CD_ACLK	I	CD-External audio clock.
101	CD_ASDATA	I	CD-Audio serial data line.
102	SPDIF_IN	I	Sony/Philips data interface-input.
103	A_ACLK	O	Output audio clock.
104	VDD	I	Power (3.3V).
105	BCLK	O	Serial DAC bit clock.
106	LRCLK	O	Serial DAC left right clock.
107	ASDATA	O	Audio serial data line.
108, 109	NC	O	Not connected.
110	VSS	I	Ground.
111	SPDIF_OUT	O	Sony/Philips data interface output.
112	AUDIO_SYNC	O	Audio sync strobe.
113, 114	TM1, TM0	I	Test mode 1, 0.
115	ZTEST	I	Test mode pin.
116	SCAN_TE	I	Scan test mode pin.
117	PREQ	O	PCM FIFO request.
118	VDD	I	Power (3.3V).
119, 120	SBD_15, 14	I/O	SDRAM data bus 15, 14.
121	NC	—	Not connected.
122	SBD_13	I/O	SDRAM data bus 13.

Pin No.	Pin Name	I/O	Description
123	VSS	I	Ground.
124 ~ 126	SBD_12 ~ 10	I/O	SDRAM data bus 12 ~ 10.
127	VDD	I	Power (3.3V).
128, 129	SBD_9, 8	I/O	SDRAM data bus 9, 8.
130	SCLK	I/O	SDRAM 81MHz clock.
131	VSS	I	Ground.
132 ~ 134	SBA_9 ~ 7	O	SDRAM address bus 9 ~ 7.
135	VDD	I	Power (3.3V).
136 ~ 138	SBA_6 ~ 4	O	SDRAM address bus 6 ~ 4.
139	VSS	I	Ground.
140 ~ 142	SBA_3 ~ 1	O	SDRAM address bus 3 ~ 1.
143	VDD	I	Power (3.3V).
144	SBA_0	O	SDRAM address bus 0.
145, 146	SBA_10, 11	O	SDRAM address bus 10, 11.
147	VSS	I	Ground.
148	SCS1	O	Chip select for second DRAM.
149	SCS	O	Chip select for SDRAM.
150	SRAS	O	SDRAM row address strobe.
151	VDD	I	Power (3.3V).
152	SCAS	O	SDRAM column address strobe.
153	SWE	O	SDRAM write enable.
154	SDQM	O	SDRAM control pin.
155	VSS	I	Ground.
166	PLLVD	I	Power-phase locked loop for SDRAM.
157	NC	—	Not connected.
158	PLLSS	I	Phase locked-loop ground pin.
159	VDD	I	Power (3.3V).
160	NC	—	Not connected.

## IC, HD6412350F20

Pin No.	Pin Name	I/O	Description
1	CS1ROM	—	Not used.
2	CS0ROM	O	Chip select output terminal for ROM.
3, 4	VSS	I	GND.
5	VCC	I	Power input terminal. EVER 5 V.
6 ~ 9	A0 ~ 3	O	Address bus output terminal.
10	VSS	I	GND.
11 ~ 18	A4 ~ 11	O	Address bus output terminal.
19	VSS	I	GND.
20 ~ 27	A12 ~ 19	O	Address bus output terminal.
28	VSS	I	GND.
29	A20	O	Not used.
30	CODEC_ERR	—	Not used.
31	INT_VDEC	I	Interrupt signal for AV DECODER IC.
32	HD_INT	I	Interrupt signal from LOADER.
33, 34	P67, 66	—	Not used.
35, 36	VSS	I	GND.
37	SCL	O	EEPROM serial clock output.
38	SDA	I/O	EEPROM serial data I/O.
39	VCC	I	Power input terminal. EVER 5 V.
40 ~ 43	D0 ~ 3	I/O	Data bus input/output terminal.
44	VSS	I	GND.
45 ~ 52	D4 ~ 11	I/O	Data bus input/output terminal.
53	VSS	I	GND.
54 ~ 57	D12 ~ 15	I/O	Data bus input/output terminal.
58	VCC	I	Power input terminal. EVER 5 V.
59	TXD0	O	Data output terminal for FL DRIVER IC serial communication control.
60	TXD1	O	Data output terminal for LOADER serial communication control.
61	RXD0	I	Data input terminal for FL DRIVER IC serial communication control.
62	RXD1	I	Data input terminal for LOADER serial communication control.
63	SCK0	O	Clock output terminal for FL DRIVER IC serial communication control.
64	SCK1	O	Clock output terminal for LOADER serial communication control.
65	VSS	I	GND.
66	CS VDEC	O	Chip select output terminal for AV DECODER IC.
67, 68	VSS	I	GND.
69	CS5	O	Chip select output terminal for SRAM.
70	DREQ1	I	MPEG decoder data request.
71	RESET FR	O	Reset for Front Board.
72	CS_FR	O	FL DRIVER IC chip select output terminal.
73	SYSRST	O	System reset signal output terminal.
74	REMOCON	I	Remote control signal input terminal.
75	USCL	O	PC clock output terminal for EEPROM, video encoder IC.



Pin No.	Pin Name	I/O	Description
76	USDA	I/O	I <sup>2</sup> C data input/output terminal for EEPROM, video encoder IC.
77	UML	O	Data enable signal output terminal for AUDIO DAC IC control.
78	UMC	O	Clock for AUDIO DAC IC control.
79	UMD	O	Data output terminal for AUDIO DAC IC control.
80	WDTOVF	O	Watch dog timer overflow signal output terminal.
81	RESET	I	Micro processor reset input terminal.
82	NMI	I	Fixed is to "H".
83	STBY	I	
84	VCC	I	Power input terminal. EVER 5 V.
85	XTAL	I	Crystal oscillator input terminal. 20 MHz.
86	EXTAL	I	
87	VSS	I	GND.
88	fO	—	Not used. (System clock output for external device.)
89	VCC	I	Power input terminal. EVER 5 V.
90	AS	—	Not used. (Address strobe.)
91	RD	O	Lead signal output terminal for bus control.
92	HWR	O	"H" write signal output terminal for bus control.
93	LWR	O	"L" write signal output terminal for bus control.
94	WAIT	O	Bus request output terminal.
95	PFO	—	Not used. (Bus request acknowlege.)
96	HRST	O	Reset signal output terminal for LOADER.
97, 98	YS SCK, YS SI	—	Not used.
99, 100	VSS	I	GND.
101	Q_SURROUND	O	Q SURROUND IC control terminal. ON = H OFF = L.
102	TEST MUTE	—	Not used.
103	AVCC	I	Power supply input terminal for A/D. EVER 5V.
104	VREF	I	Reference voltage input terminal for A/D. EVER 5V.
105	V-DET	—	Not used.
106	NTSC/PAL	I	NTSC: L, PAL: H (for DVD output)
107	REGION	I	DVD REGION CODE, 1: 0 ~ 1 V, 2: 1 ~ 2 V, 3: 2 ~ 3 V, 4: 3 ~ 4 V, 5: 4 ~ 5 V.
108	ECOHVOL	I	Karaoke echo volume control 0 ~ 5 V.
109	SW	I	NTSC/PAL serect (for VIDEO CD) (Not used).
110	C2PO	—	Not used.
111	EMPH	—	Not used.
112	SV2	O	Voltage output for S2 terminal. S1 = 5V S2 = 2.5 V Normally = 0 V.
113	AVSS	I	GND.
114	VSS	I	
115	AK4527CS	—	Not used. (pull up)
116	RGB/YC	—	Not used.
117	YS912 CBS	—	Not used. (pull up)
118	CS-KARAOKE	—	Not used. (pull up)

Pin No.	Pin Name	I/O	Description
119	AMUTE	O	Audio signal (analog audio) output mute control terminal ON = H OFF = L.
120	POWER ON	O	Power supply control terminal ON = H OFF = L.
121	A MUTE AC-3	—	Not used.
122	YS917 CS	—	Not used,
123, 124	MD0, 1	I	Operation mode control Fixed to L.
125	MD2	I	Operation mode control Fixed to H.
126	PG0	—	Not used. (VMUTE control)
127	LID	I	OPEN/CLOSE sensor
128	RDY HIF	I	Front END $\mu$ com RDY

IC, LC87F72C8A

Pin No.	Pin Name	I/O	Description
1	SUBRXD	I	DATA input terminal for LOADER serial communication control.
2	SUBSCK	I	Clock input terminal for LOADER serial communication control.
3	LEDD1	O	Detection of LEDD1.
4	LEDCSB	O	Detection of LEDCSB.
5	LEDCLK	O	Detection of LEDCLK.
6	RDY_HIF	O	LOADER READY signal output terminal.
7	PWM	O	Detection of PWM.
8	RESET	I	Reset signal input terminal.
9	XT1/AN10	I	Input for 32.768kHz crystal oscillation. AD input port: AN10. (Connected to power supply)
10	XT2/AN11	I/O	Out put for crystal oscillation. AD input port: AN11. (Not Connected)
11	GND	—	GND.
12	CLOCK	I	In put for 10MHz crystal oscillation.
13	CLOCK	O	Out put for 10MHz crystal oscillation.
14	+5V	—	Power supply 5V.
15	TESTKEY	O	TESTKEY output pin.
16	BUSYB	I	DSP command dispose busy signal input pin.
17	FBUSYB	I	DSP command receiver busy signal input pin.
18	HEXKEY	O	Detection of HEXKEY.
19	P84/AN4	O	Detection of P84/AN4.
20	OPEN_SW	O	Detection of OPEN SW.
21	CLOSE_SW	O	Detection of CLOSE SW pin.
22	LSW	I	LIMIT SW input pin.
23	HIRQB	I	Interrupt signal input pin.
24	INT_SUBSCK	I	Clock input terminal for LOADER serial communication control.
25	FGO	I	SENDER input.
26	WRQ	I	Subcode Q read ready monitor input.
27	S0/PA0	O	LCD display segment output. (Not Connected)
28	FEL_CSBI	O	Chip select signal output pin.
29	FEL_CSBO	O	Chip select signal output pin.
30	ZWR	O	Write signal output pin.
31	ZRD	O	Read signal output pin.
32	S5/PA5	O	FECNT control output pin.
33	WAITB	I	Wait signal input pin.
34	S7/PA7	I/O	Detection of S7/PA7.
35 ~ 42	DB0 ~ 7	I/O	Data 0 ~ 7.
43 ~ 50	AB0 ~ 7	O	Address 0 ~ 7.
51	+5V	—	Power supply 5V.
52	GND	—	GND.
53	S24/PD0	O	Detection of S24/PD0.
54	DEFINHB	O	DEFINHB control output.
55	TOPEN	I	RF general-purpose port output pin 0.

Pin No.	Pin Name	I/O	Description
56	CURRENT	I	RF general-purpose port output pin 2.
57	RW_DISC	O	RW DISC control output pin.
58	DUAL	O	DUAL control output pin.
59	DECRESB	O	Decoder reset output pin.
60	EVARESOB	O	System reset output pin.
61 ~ 65	AB8-12	O	Address 8-12.
66-68	S37-39/PE5 ~ 7	O	Detection of S37-39/PE5 ~ 7.
69 ~ 72	CONT1-4	O	CONT1-4 output pin.
73	S44/PF4	O	Detection of S44/PF4.
74, 75	OUT 1, 2	O	Detection of OUT 1, 2.
76	HD_INT	O	Interrupt signal for AV DECODER IC/TEST PIN.
77 ~ 79	V3-1/PL6 ~ 4	O	Detection of V3-1/PL6 ~ 4.
80 ~ 83	COM0-3/PL0 ~ 3	O	Detection of COM0-3/PL0 ~ 3.
84	TRY_FWD	O	TRY control output.
85	TRY_REV	O	TRY control output.
86	GND	—	GND.
87	+5V	—	Power supply pin (+).
88	DMUTE	O	MUTE output pin.
89	F_DIO	O	F_DIO output pin.
90	F_CLK	O	F_CLK output pin.
91	F_DIOI	O	F_DIOI output pin.
92	DPD_TEB	O	DPD_TEB output.
93	RFSCCT	O	RFSCCT control output.
94	XQBH	O	XQBH out put. (Not Connected)
95	EQSCT	O	EQSCT output.
96	CD3T	O	CD3T control output.
97	PP_TEB	O	PP TEB output.
98, 99	LDON1, 2	O	LDON 1, 2 output.
100	SUBTXD	O	DATA output terminal for LOADER serial communication control.

## IC, LC78660W

Pin No.	Pin Name	I/O	Description
1	RFPI	I	RF input port pin. (Pull down)
2	TEST0	I/O	Tracking margin signal I/O pin.
3	DVDD2	—	A/D D/A internal logic power supply. [Digital 5V]
4	DVSS	—	Digital GND.
5	AD5/BH	I	Servo A/D input pin. (AD5: Assistant input 5)
6	AD4/PH/TE	I	Servo A/D input pin. (AD4: Assistant input 4)
7	AD3	I	Servo A/D input pin. (AD3: Assistant input 3)
8	AD2	I	Servo A/D input pin. (AD2: Assistant input 2)
9	AD1/JV	I	Servo A/D input pin. (AD1: Assistant input 1)
10	AD0/RREC	I	Servo A/D input pin. (AD0: Assistant input 0)
11	RF_PH	I	Servo A/D input pin. (RF_PH: RF peak hold signal)
12	RF_BH	I	Servo A/D input pin. (RF_BH: RF bottom hold signal)
13	TE	I	Servo A/D input pin. (TE: Tracking error signal)
14	FE	I	Servo A/D input pin. (FE: Focus error signal)
15	TEST0	I	Test input pin 0. (L Fixed)
16	EFMINP	I	EFM/EFM+input pin.
17	TEST1	I	Test input pin 1. (L Fixed)
18	EFMINN	I	EFM-input pin.
19	SLCLPF0	—	SLC LPF pin.
20	SLCLPF1	—	SLC LPF pin.
21	SLC01	—	SLC control pin.
22	SLC02	—	SLC control pin.
23	AVDD1	—	A/D D/A SLC power supply. [Analog 5V]
24	ADSS	—	Analog GND.
25	VREF	O	Servo D/A standard voltage.
26	SLCBIAS	O	Servo D/A output pin. (SLCBIAS: SLC standard voltage signal)
27	TESBIAS	O	Servo D/A output pin. (TESBIAS: TES standard voltage signal)
28	HFLBIAS	O	Servo D/A output pin. (HFLBIAS: HFL standard voltage signal)
29	OFSET	O	Servo D/A output pin. (OFSET: Assistant signal)
30	BCA	O	Servo D/A output pin. (BCA: Assistant signal)
31	BOOT3T	O	Servo D/A output pin. (BOOT3T: Assistant signal)
32	RFVCA	O	Servo D/A output pin. (RFVCA: Assistant signal)
33	TBAL	O	Servo D/A output pin. (TBAL: Tracking balance control signal)
34	FBAL	O	Servo D/A output pin. (FBAL: Focus balance control signal)
35	SGC	O	Servo D/A output pin. (SGC: Assistant signal)
36	SLSO	O	Servo D/A output pin. (SLSO: Thread control signal)
37	SPDO	O	Servo D/A output pin. (SPDO: Spindle control signal)
38	TDO	O	Servo D/A output pin. (TDO: Tracking control signal)
39	FDO	O	Servo D/A output pin. (FDO: Focus control signal)
40	DVSS	—	Digital GND.
41	DVDD0	—	Internal logic power supply. [Digital 3.3V]

Pin No.	Pin Name	I/O	Description
42	FG	I	FG counter input pin.
43	EVENT	I	EVENT counter input pin. (Pull down)
44	HFLIO	I/O	Mirror detest signal I/O pins.
45 ~ 48	PP0 ~ 3	I/O	General-purpose port 0 ~ 3. (Pull down)
49	WRQ	O	Subcode Q read ready monitor pin.
50	HFBUSYB	O	DSP command dispose busy signal output pin.
51	HBUSYB	O	DSP command receiver busy signal output pin.
52	DVDD3	—	I/O power supply. [Digital 5V]
53	DVSS	—	Digital GND.
54	HWAITB	O	Wait signal output pin.
55	HIRQB	O	Interrupt signal output pin.
56	DVDRESB	I	Decoder reset input pin.
57	RESB	I	System reset input pin.
58	HRDB	I	Read signal input pin.
59	HWRB	I	Write signal input pin.
60	HCSB	I	Chip select signal input pin.
61 ~ 68	HDATA0 ~ 7	I/O	Data0 ~ 7.
69 ~ 81	HADR0 ~ 12	I	Address0 ~ 12.
82	DVDD3	—	I/O power supply. [Digital 5V]
83	DVSS	—	Digital GND.
84	PW/FSEQ	O	Subcode [P, Q, R, S, T, U, V and W] data output pin.
85	SBCK	I	Subcode data readout shift clock input pin. (Connected to GND)
86	SBSY	O	Subcode block synchronization signal output pin. (No connected)
87	SFSY	O	Subcode frame synchronization signal output pin.
88	FSX	O	CD1 frame synchronization signal.
89	EFLG	O	Error correction C1, C2 correction conditions monitor pins.
90, 91	PP4, 5	I/O	General-purpose port4, 5. (Pull down)
92	X16MOUT	O	Internal 16MHz output pin. (No connected)
93	X16MIN	I	External 16MHz input pin.
94	TEST2	I	Test input pin2. (L Fixed)
95	DVDCKOUT	O	Internal DVD clock output pin.
96	DVDCKIN	I	External DVD clock input pin. (Pull down)
97	TEST3	I	Test input pin3. (L Fixed)
98	DVDD0	—	Internal logic power supply. [Digital 3.3V]
99	DVSS	—	Digital GND.
100	VPDO	—	SYSTEM PLL filter connection pin.
101	VRPFR	—	SYSTEM PLL VCO oscillator range adjustment pin.
102	VCOC	—	SYSTEM PLL filter connection pin.
103	AVSS	—	Analog GND.
104	AVDD3	—	SYSTEM VCO power supply. [Analog 3.3V]
105	DVSS	—	Digital GND.

Pin No.	Pin Name	I/O	Description
106	XIN	I	Oscillator circuit input pin.
107	XOUT	O	Oscillator circuit output pin.
108	DVDD6	—	Oscillator circuit power supply. [Digital 3.3V]
109, 110	PP6, 7	I/O	General-purpose port6, 7. (Pull down)
111	AVREQIO	I/O	AV data demand flag I/O pins.
112	AVACKOI	I/O	AV data read strobe output pin.
113	AVDACK	O	AV data read (Clock/Enable) output pins.
114	AVSCTB	O	AV output sector synchronization output pin.
115	AVERRB	O	AV data reliable flag output pin.
116	DVSS	—	Digital GND.
117	DVDD4	—	I/O power supply. [Digital 3.3V or 5V]
118 ~ 125	AVD0 ~ 7	O	AV data0 ~ 7.
126	C2F	O	C2 flag output pin.
127	ROMXA	O	CD data output pin.
128	ROMCK	O	CD data output shift lock output pin.
129	LRSY	O	CD data output L/R clock output pin.
130	EMPH	O	Deemphasis monitor pin.
131	DOUT	O	Audio EIAJ data output pin.
132	DVDD4	—	I/O power supply. [Digital 3.3V or 5V]
133	DVSS	—	Digital GND.
134	EFMOUT	O	EFM 2 value signal output pin.
135	LEFM	O	Output pin for the signal picked out from EFM binary signal with PCK.
136	PCK	O	EFM playback shift clock output pin.
137	DVDD4	—	Inner logic power supply. [Digital 3.3V]
138	DVSS	—	Digital GND.
139	VCOCTL	—	VCO filter connection pin.
140	PPDO	—	Phase comparison filter connection pin.
141	FPDO	—	Frequency comparison filter connection pin.
142 ~ 144	LF1 ~ 3	—	Filter connection pin1 ~ 3.
145	PCN	—	Voltage monitor pin. (Phase comparison charge pump PCH control voltage)
146	PISET	—	Current setting pin for the constant-current phase comparison charge pump.
147	FISET	—	Current setting pin for the constant-current frequency comparison charge pump.
148	CDFR	—	EFM playback VCO oscillator range setting pin. [For CD] (Pull down)
149	DVDFR	—	EFM playback VCO oscillator range setting pin. [For DVD] (Pull down)
150	AVDD2	—	EFM PLL JV power supply. [Analog 5V]
151	AVSS2	—	Analog GND.
152, 153	JVCPI, JVCPC	—	JV control pin.
154	JVAO	O	EFM playback PLL clock jitter output pin.
155	JVAIN	—	JV control pin. (Pull down)
156	JVRVO	—	JV control pin. (No connected)
157	AVDD4	—	SYSTEM PLL power supply. [Analog 3.3V]

Pin No.	Pin Name	I/O	Description
158	AVSS	—	Analog GND.
159 ~ 166	MD15 ~ 8	I/O	DRAM data15 ~ 8.
167	DVDD5	—	I/O power supply. [Digital 5V]
168	DVSS	—	Digital GND.
169 ~ 176	MD7 ~ 0	I/O	DRAM data7 ~ 0.
177 ~ 184	MA0 ~ 7	O	DRAM address0 ~ 7.
185	DVDD5	—	I/O power supply. [Digital 5V]
186	DVSS	—	Digital GND.
187	MA8	O	DRAM address8.
188 ~ 191	MA9-12	O	DRAM address9 ~ 12. (No connected)
192	MRAS0B	O	RAS output pin0.
193	MRAS1B	O	RAS output pin1. (No connected)
194	MCASUB	O	CAS output pin. (Upper Byte)
195	MCASLB	O	CAS output pin. (Lower Byte)
196	MOEB	O	OE output pin.
197	MWEB	O	WE output pin.
198	DVSS	—	Digital GND.
199	DVDD0	—	Inner logic power supply. [Digital 3.3V]
200 ~ 204	RFP0 ~ 4	O	RF general-purpose port output pin0 ~ 4.
205	DBFECTO	O	Defect signal output pin.
206	DEFECTTI	I	Defect signal input pin.
207	DVSS	—	Digital GND.
208	DVDD1	—	I/O power supply. [Digital 5V]



## IC, LA9702W

Pin No.	Pin Name	I/O	Description
1	RFM	I	RF signal - input. (Pull down)
2	RFP	I	RF signal + input.
3	PD1	I	Pickup signal input.
4	PD2	I	Pickup signal input.
5	PD3	I	Pickup signal input.
6	PD4	I	Pickup signal input.
7	PD5	I	Pickup signal input.
8	PD6	I	Pickup signal input.
9	PD7	I	Pickup signal input.
10	PD8	I	Pickup signal input.
11	PD9	I	Pickup signal input.
12	VCC	—	Power supply. (Servo signal system)
13	LDD1	O	APC1 output.
14	LDS1	I	APC1 monitor voltage input.
15	LDD2	O	APC2 output.
16	LDS2	I	APC2 monitor voltage input.
17	GND	—	Ground. (Servo signal system)
18	SGC	I	Servo gain control terminal. (RREC, FE, TE)
19	FBAL	I	Focus balance adjustment terminal.
20	TEBL	I	Tracking balance adjustment terminal.
21	VGA	I	RF gain adjustment terminal.
22	BST	I	Equalizer boost adjustment terminal.
23	FOST	I	Focus offset adjustment terminal.
24	TOST	I	Tracking offset adjustment terminal.
25	BCATH	I	BCA threshold adjustment terminal.
26	REFI	I	Reference voltage setting terminal.
27	2.5V OUT	O	Reference voltage output for servo signal.
28	RRBC	O	Reflection output.
29	FE	O	Focus error output.
30	TE	O	Tracking error output.
31	THC	—	External capacitor for setting TE hold time constant is connected to this terminal.
32	WO	O	Warble output terminal.
33	ISET	—	External resistor for setting BPF center frequency is connected to this terminal. (Pull down)
34	WOI	I	Push-pull signal input.
35	WOO	O	Push-pull signal output.
36	TEO	—	TE gain setting terminal for 3 beam.
37	TEN	—	TE gain setting terminal for 3 beam.
38	CP	—	External resistor and capacitor for setting charge pump gain, are connected to this terminal.
39	BHI	—	External resistor for setting bottom hold detection constant, is connected to this terminal. (Pull down)
40	RFON	O	RF - output.

Pin No.	Pin Name	I/O	Description
41	RFOP	O	RF + output.
42	BH	O	RF bottom detection output.
43	PHI	—	External resistor for setting peak hold detection constant, is connected to this terminal. (Pull down).
44	PH	O	RF peak detection output.
45	BCA	O	BCA output.
46	DEF	O	Defect output. (H: Defect detection)
47	DEFC	—	External resistor for defect detection is connected to this terminal.
48	TC	—	External resistor for setting defect detection constant is connected to this terminal.
49	GND	—	Ground. (DPD system)
50	LPC	—	External capacitor for RF DC servo is connected to this terminal.
51	CPOF	I	Charge pump OFF terminal. (H: OFF)
52	EQO2	—	RF equalizer setting terminal.
53	TH	I	Tracking hold. (H: Hold)
54	EQL2	I	RF equalizer setting terminal.
55	VCC	—	Power supply. (DPD system)
56	EQO4	O	RF equalizer setting terminal.
57	XHTR	I	Tracking bottom detection band switch. (L: High band)
58	BQL4	I	RF equalizer setting terminal.
59	XQBH	I	Bottom detection constant switch. (L: High speed)
60	EQO3	O	RF equalizer setting terminal.
61	EQSCT	I	Equalizer switcher. (H: 77-pin selection, L: 52-pin selection)
62	EQI3	I	RF equalizer setting terminal.
63	DPD/TEB	I	DPD 3-beam tracking switcher. (H: DPD)
64	RFO2	O	RF output.
65	RFO1	O	RF output.
66	VCC	—	Power supply. (RF system)
67	EQI1	I	RF equalizer setting terminal.
68	TE/PP	I	3-beam push-pull tracking switcher. (L: 3-beam)
69	EQO1	O	RF equalizer setting terminal.
70	LDON2	I	APC2 laser ON terminal. (H: ON)
71	EQI2	I	RF equalizer setting terminal.
72	LDON1	I	APC1 laser ON terminal. (H: ON)
73	EQO2	O	RF equalizer setting terminal.
74	GND	—	Ground. (RF system)
75	EQL1	I	RF equalizer setting terminal.
76	RFSCCT	I	RF input switcher. (H: RF different input, PP error)
77	EQO1	O	RF equalizer setting terminal.
78	CAO	O	Customer amplifier output.
79	PREF	—	Reference voltage output. (for pick)
80	OAN	I	Customer amplifier input.

IC, HN58X2416FPI

Pin No.	Pin Name	I/O	Description
1 ~ 3	NC	—	Not used.
4	VSS	—	Ground
5	SDA	I/O	Serial data input/output
6	SCL	I	Serial clock input
7	WP	I	Write protect
8	VCC	—	Power supply

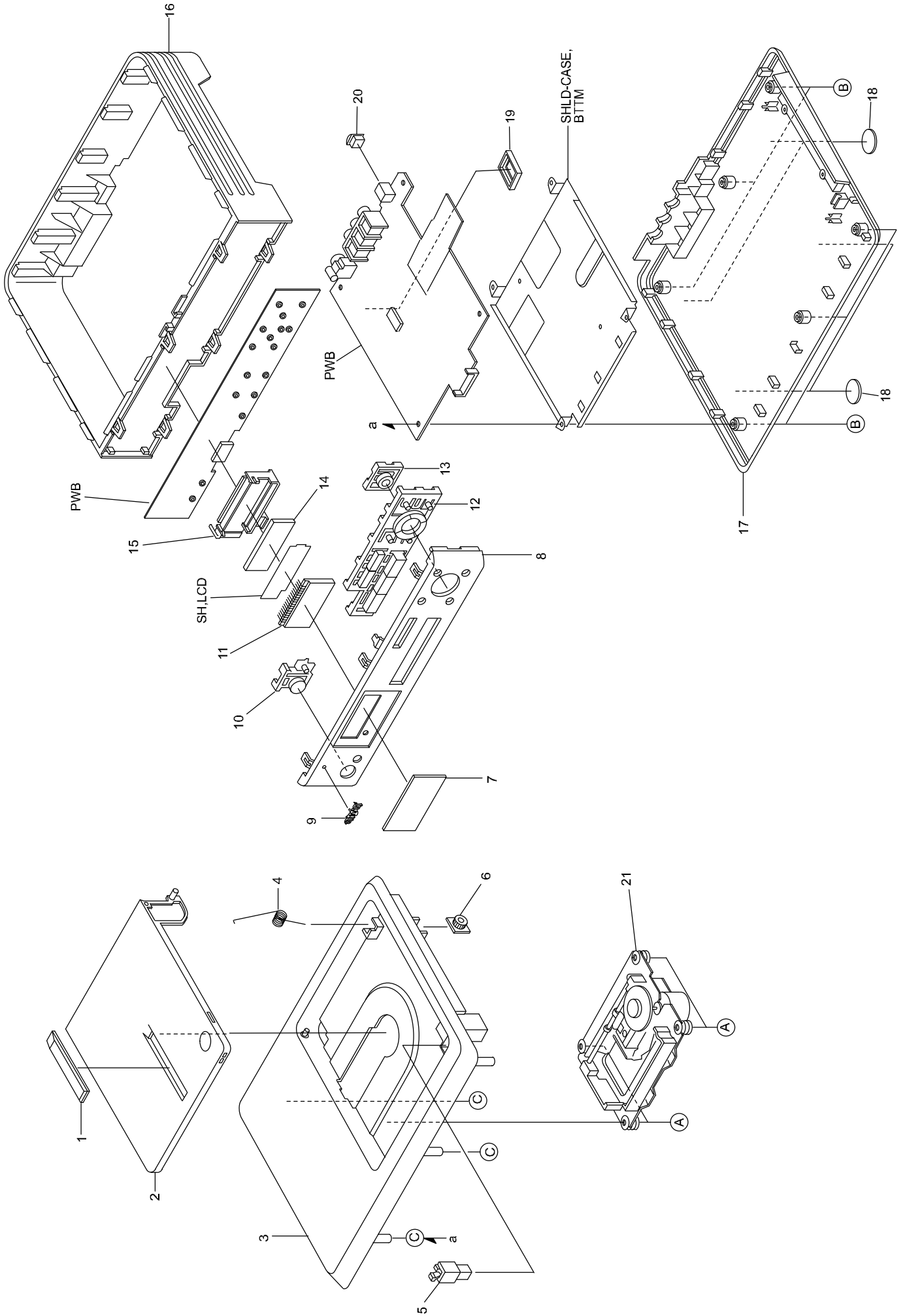

# MECHANICAL PARTS LIST 1 / 1

REF. NO	PART NO.	KANRI NO.	DESCRIPTION
1	8A-AV6-007-010		WINDOW,LID
2	8A-AV6-029-010		LID,DISK SDV
3	8A-AV6-026-010		CABI, TOP SDV
4	8A-AV6-205-010		SFR-T,LID
5	87-036-389-010		SW,PUSH 1-1-1 R8120125
6	87-063-164-010		OIL-DMER,
7	8A-AV6-030-010		WINDOW,LCD SDV
8	8A-AV6-028-010		CABI,FRONT SDV
9	8A-AV6-008-010		BADGE,AIWA 25 SIL
10	8A-AV6-009-010		KEY,POWER
11	8A-AV6-608-010		LCD,AAV-6
12	8A-AV6-033-010		KEY,PLAY SDV
13	8A-AV6-034-010		KEY,ENTER SDV
14	8A-AV6-202-010		LENS,LCD
15	8A-AV6-201-010		HLD, LCD
16	8A-AV6-038-010		CABI,CNTR SDV HR
17	8A-AV6-041-110		CABI,BTMM SDV EZ
18	8A-AV6-215-010		FOOT,19-1.5
19	87-A91-554-010		COVER,2-44P IC179-44600
20	87-HC4-014-010		COVER, OPT
21	M8-AZK-J93-070		MECHA, DV32BF2 DVD
A	8A-ZG1-201-010		S-SCREW,MECH 880
B	87-067-581-010		TAPPING SCREW, BVT2+3-15
C	87-B10-307-010		VET2+2.6-12 W/O SLOT

## COLOR NAME TABLE

Basic color symbol	Color	Basic color symbol	Color	Basic color symbol	Color
B	Black	C	Cream	D	Orange
G	Green	H	Gray	L	Blue
LT	Transparent Blue	N	Gold	P	Pink
R	Red	S	Silver	ST	Titan Silver
T	Brown	V	Violet	W	White
WT	Transparent White	Y	Yellow	YT	Transparent Yellow
LM	Metallic Blue	LL	Light Blue	GT	Transparent Green
LD	Dark Blue	DT	Transparent Orange	GM	Metallic Green
YM	Metallic Yellow	DM	Metallic Orange	PT	Transparent Pink
LA	Aqua Blue	GL	Light Green	HT	Transparent Gray

# GENERAL SPEAKER DISASSEMBLY INSTRUCTIONS (FOR REFERENCE)

## Type.1

Insert a flat-bladed screwdriver into the position indicated by the arrows and remove the panel. Remove the screws of each speaker unit and then remove the speaker units.

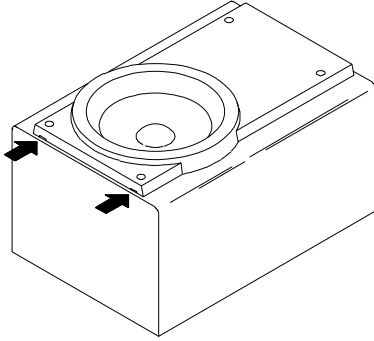

## Type.2

Remove the grill frame and four pieces of rubber caps by pulling out with a flat-bladed screwdriver. Remove the screws from hole where installed rubber caps. Insert a flat-bladed screwdriver into the position indicated by the arrows and remove the panel. Remove the screws of each speaker unit and then remove the speaker units.

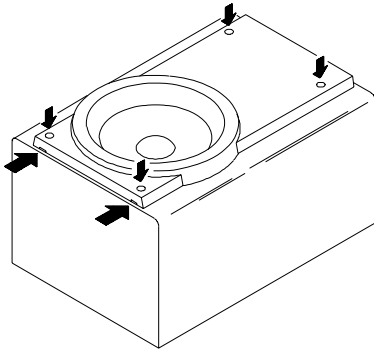

## Type.3

Insert a flat-bladed screwdriver into the position indicated by the arrows and remove the panel. Turn the speaker unit to counter-clockwise direction while inserting a flat-bladed screwdriver into one of the hollows around speaker unit, and then remove the speaker unit. After replacing the speaker unit, install it turning to clockwise direction until "click" sound comes out.

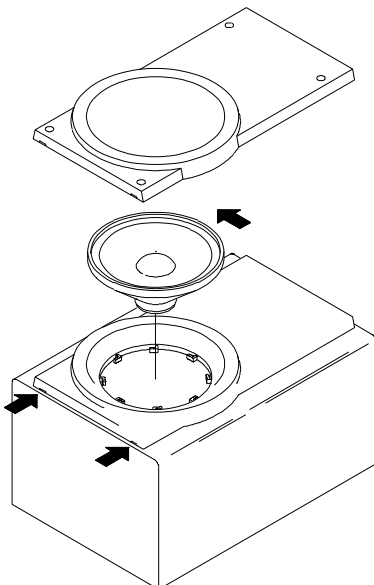

## Type.4

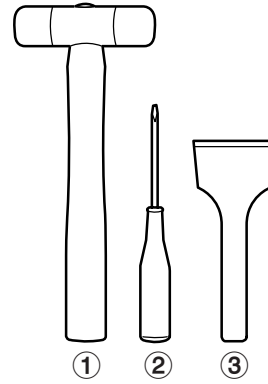

## TOOLS

- ① Plastic head hammer
- ② (⊖) flat head screwdriver
- ③ Cut chisel

## How to Remove the PANEL, FR

1. Insert the (⊖) flat head screwdriver tip into the gap between the PANEL, FR and the PANEL, SPKR. Tap the head of the (⊖) flat head screwdriver with the plastic hammer head, and create the clearance as shown in Fig-1.
2. Insert the cut chisel in the clearance, and tap the head of the cut chisel with plastic hammer as shown in Fig-2, to remove the PANEL, FR.
3. Place the speaker horizontally. Tap head of the cut chisel with plastic hammer as shown in Fig-3, and remove the PANEL, FR completely.

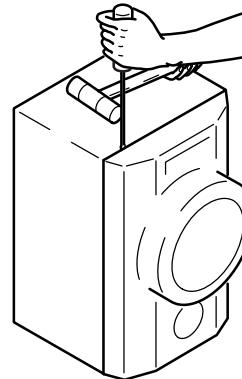

Fig-1

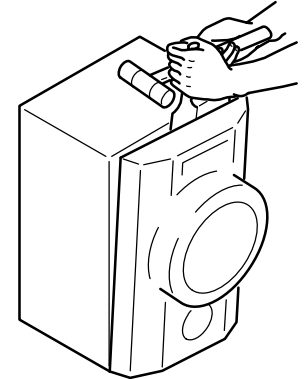

Fig-2

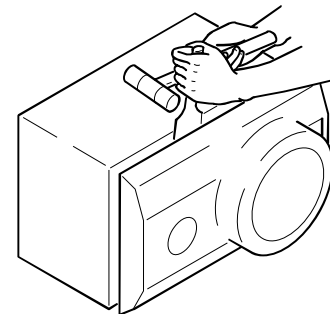

Fig-3

## How to Attach the PANEL, FR

Attach the PANEL, FR to the PANEL, SPKR. Tap the four corners of the PANEL, FR with the plastic hammer to fit the PANEL, FR into the PANEL, SPKR completely.

## SPEAKER PARTS LIST (SX-AVW50) <YSC>

REF. NO.	PART NO.	KANRI NO.	DESCRIPTION
1	8A-ASB-014-010		CABI,FR CS
2	8A-ASB-009-010		CABI,FR MS
3	8A-ASB-015-010		CABI,RE CS
4	8A-ASB-010-010		CABI,RE MS
5	8A-ASB-612-010		CORD, SPKR 30M
6	8A-AS2-006-010		COVER
7	8A-ASB-002-010		GRILLE,FRAME ASSY
8	8A-ASB-016-010		GRILLE,FRAME ASSY CS
9	8A-ASB-011-010		GRILLE,FRAME ASSY MS
10	8A-ASB-005-010		PANEL,DUCT
11	8A-ASB-606-010		SPKR, 140
12	8A-ASB-602-010		SPKR, 70 FR
13	8A-ASB-603-010		SPKR, 70 RE
14	8A-ASB-604-010		SPKR, 70C
15	8A-ASB-006-010		TERMINAL
16	8A-AS1-013-010		TERMINAL

## SPEAKER PARTS LIST (SX-CR677) <YJ3ST1L>

NOTE: This SX-CR677 Speaker contains SX-C607 (Center Speaker) and SX-R277 (Surround Speakers).

REF. NO.	PART NO.	KANRI NO.	DESCRIPTION
1	8Z-YS1-023-010		GRILLE,FRAME ASSY G<R277>
2	8Z-YS1-601-110		SPKR,100<R277>
3	87-YS6-002-010		SPKR,CORD Y<R277>
4	81-VSA-009-010		CORD,BUSH<R277>
5	87-010-384-010		CAP,E 100-25 M SME<R277>
6	8Z-YS2-027-010		GRILLE,FRAME ASSY G<C607>
7	87-YS7-012-010		PANEL,FR S<C607>
8	87-YS7-604-010		SPKR,100<C607>
9	83-NSM-010-010		SPKR,CORD<C607>
10	81-VSA-009-010		CORD,BUSH<C607>

## ACCESSORIES / PACKAGE LIST

REF. NO.	PART NO.	KANRI NO.	DESCRIPTION
1	8A-AX1-906-010		IB,EZ(9L)S
2	87-A90-054-010		ANT,LOOP AM-CON C
3	87-A90-118-010		ANT WIRE,FM(Z)
4	8A-AR6-701-010		RC UNIT,RC-AAR05 BLK
4	8A-AV6-620-010		RC UNIT,RC-AVL01
5	87-A80-167-010		CORD,PIN IPY 150 CM
△	6 87-B30-415-010		AC ADAPTOR,AC-D1003ENC
△	7 87-050-076-010		AC CORD SET ASSY,E
8	87-A80-179-010		CORD,PIN VIDEO 50 Y
△	9 87-A80-180-010		CORD,POWER EIAJ 10
△	10 87-B30-480-010		CABLE,OPTICAL TOS 50CM

**アイワ株式会社** 〒110-8710 東京都台東区池之端1-2-11 ☎03(3827)3111 (代表)  
**AIWA CO.,LTD.** 2-11, IKENOHATA 1-CHOME, TAITO-KU, TOKYO 110, JAPAN TEL:03 (3827) 3111

9301978 920074 2000041 0251431

Printed in Singapore