

aiwa

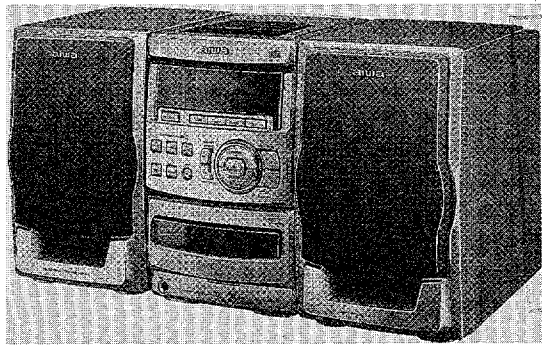

LCX-350
LCX-352
LCX-358



COMPACT DISC STEREO SYSTEM

- BASIC TAPE MECHANISM: 2ZM-1 R6
- BASIC CD MECHANISM: KSM-2131 BDM
- TYPE: LH<350>, K<350>, EZ<352,358>

REVISION PUBLISHING

This Service Manual is the "Revision Publishing" and replaces "Simple Manual"
(S/M Code No. 09-986-287-10A).

ACCESSORIES/PACKAGE LIST

DESCRIPTIONで判断できない物は "REFERENCE NAME LIST" を参照してください。
If can't understand for Description please kindly refer to "REFERENCE NAME LIST".

REF. NO	PART NO.	KANRI NO.	DESCRIPTION
1	88-CL5-628-010		ANT, LOOP
2	87-A90-118-010		ANT, WIRE FM (Z)<EXCEPT 350LH>
2	88-CL5-626-010		FEEDER-ANT, FM<350LH>
3	88-CLF-906-010		IB, E (9L) B<358EZ>
3	88-CL5-906-010		IB, E (9L) B<352EZ>
3	88-CL5-905-010		IB, K (E) B<350K>
3	88-CL5-902-010		IB, LH (ESP) B<350LH>
△	4	87-A90-312-010	PLUG, CONVERSION WTN-1157R1<350LH>
5	88-CL5-951-010		RC UNIT, RC-8AT02

SPECIFICATIONS

K, EZ MODELS:

FM tuner section

Tuning range 87.5 MHz to 108 MHz
Usable sensitivity (IHF) 13.2 dBf
Antenna terminals 75 ohms (unbalanced)

MW tuner section

Tuning range 531 kHz to 1602 kHz (9 kHz step)
 530 kHz to 1710 kHz (10 kHz step)
Usable sensitivity 350 μ V/m
Antenna Loop antenna

LW tuner section

Tuning range 144 kHz to 290 kHz
Usable sensitivity 1400 μ V/m
Antenna Loop antenna

LH MODEL:

FM tuner section

Tuning range 87.5 MHz to 108 MHz
Usable sensitivity (IHF) 13.2 dBf
Antenna terminals 75 ohms (unbalanced)

AM tuner section

Tuning range 530 kHz to 1710 kHz (10 kHz step)
 531 kHz to 1602 kHz (9 kHz step)
Usable sensitivity 350 μ V/m
Antenna Loop antenna

Amplifier section

LCX-358 MODEL:

Power output Rated: 8 W + 8 W (6 ohms, T.H.D. 1%, 1 kHz/DIN 45500)
 Reference: 11 W + 11 W (6 ohms, T.H.D. 10%, 1 kHz/DIN 45324)
DIN MUSIC POWER 17 W + 17 W
AUX: 0.5 V
Input SPEAKERS: accept speakers of 6 ohms or more
Outputs PHONES (stereo minijack): accepts headphones of 32 ohms or more

LCX-352 MODEL:

Power output Rated: 8 W + 8 W (8 ohms, T.H.D. 1%, 1 kHz/DIN 45500)
 Reference: 10 W + 10 W (8 ohms, T.H.D. 10%, 1 kHz/DIN 45324)
DIN MUSIC POWER 16 W + 16 W
AUX: 0.5 V
Input SPEAKERS: accept speakers of 8 ohms or more
Outputs PHONES (stereo minijack): accepts headphones of 32 ohms or more

LCX-350 MODEL:

Power output 10 W + 10 W (1 kHz, T.H.D. 10%, 8 ohms)
Total harmonic distortion 0.1 % (5 W, 1 kHz, 8 ohms)
Input AUX: 0.5 V
Outputs SPEAKERS: accept speakers of 8 ohms or more
 PHONES (stereo minijack): accepts headphones of 32 ohms or more

Cassette deck section

Track format 4 tracks, 2 channels stereo
Frequency response Normal tape: 50 Hz - 15000 Hz
Recording system AC bias
Heads Recording/playback \times 1
 Erase head \times 1

Compact disc player section

Laser Semiconductor laser ($\lambda = 780$ nm)
D-A converter 1 bit linear
Wow and flutter Unmeasurable

SPEAKER SYSTEM

LCX-358 MODEL:

Cabinet type 3 way, bass reflex
Speakers Woofer: 120 mm cone type
 Cardioid speaker: 60 mm cone type
 Tweeter: 20 mm cone type
Impedance 6 ohms
Dimensions (W \times H \times D) 175 \times 261 \times 247 mm
Weight 1.6 kg

LCX-352 MODEL:

Cabinet type 2 way, bass reflex
Speakers Woofer: 100 mm cone type
 Tweeter: 25 mm ceramic type
Impedance 8 ohms
Dimensions (W \times H \times D) 160 \times 255 \times 253.5 mm
Weight 1.5 kg

LCX-350 MODEL:

Cabinet type 1 way, bass reflex
Speakers 100 mm cone type
Impedance 8 ohms
Dimensions (W \times H \times D) 160 \times 255 \times 253.5 mm
Weight 1.5 kg

GENERAL

K, EZ MODELS:

Power requirements AC : 230 V, 50 Hz
 DC : 12 V
Power consumption 35 W
Dimensions of main unit (W \times H \times D) 160 \times 255 \times 244 mm
Weight of main unit 3.1 kg

LH MODEL:

Power requirements AC : 110 - 120 V/220 - 240 V, switchable 50/60 Hz
 DC : 12 V
Power consumption 33 W
Dimensions of main unit (W \times H \times D) 160 \times 255 \times 244 mm
Weight of main unit 3.1 kg

● Design and specifications are subject to change without notice.

PROTECTION OF EYES FROM LASER BEAM DURING SERVICING

This set employs laser. Therefore, be sure to follow carefully the instructions below when servicing.

WARNING!

WHEN SERVICING, DO NOT APPROACH THE LASER EXIT WITH THE EYE TOO CLOSELY. IN CASE IT IS NECESSARY TO CONFIRM LASER BEAM EMISSION. BE SURE TO OBSERVE FROM A DISTANCE OF MORE THAN 30cm FROM THE SURFACE OF THE OBJECTIVE LENS ON THE OPTICAL PICK-UP BLOCK.

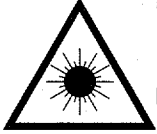

- Caution: Invisible laser radiation when open and interlocks defeated avoid exposure to beam.
- Advarsel: Usynlig laserstråling ved åbning, når sikkerhedsafbrydere er ude af funktion. Undgå udsættelse for stråling.

VAROITUS!

Laiteen Käyttäminen muulla kuin tässä käyttöohjeessa mainitulla tavalla saattaa altistaa käyttäjän turvallisuusluokan 1 ylittävälle näkymättömälle lasersäteilylle.

WARNING!

Om apparaten används på annat sätt än vad som specificeras i denna bruksanvisning, kan användaren utsättas för osynlig laserstrålning, som överskrider gränsen för laserklass 1.

CAUTION

Use of controls or adjustments or performance of procedures other than those specified herein may result in hazardous radiation exposure.

ATTENTION

L'utilisation de commandes, réglages ou procédures autres que ceux spécifiés peut entraîner une dangereuse exposition aux radiations.

ADVARSEL!

Usynlig laserstråling ved åbning, når sikkerhedsafbrydere er ude af funktion. Undgå udsættelse for stråling.

This Compact Disc player is classified as a CLASS 1 LASER product.

The CLASS 1 LASER PRODUCT label is located on the rear exterior.

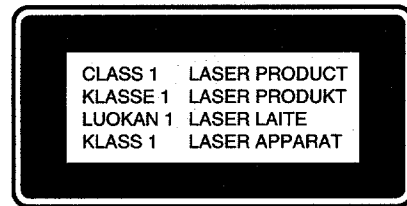

Precaution to replace Optical block (KSS-213B)

Body or clothes electrostatic potential could ruin laser diode in the optical block. Be sure ground body and workbench, and use care the clothes do not touch the diode.

- 1) After the connection, remove solder shown in the right figure.

PICK-UP Assy P.C.B

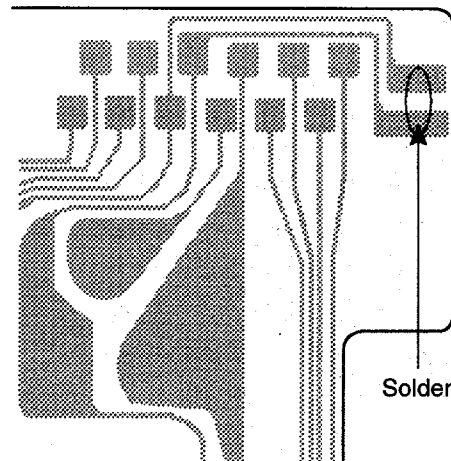

ELECTRICAL MAIN PARTS LIST

DESCRIPTIONで判断できない物は "REFERENCE NAME LIST" を参照してください。
 If can't understand for Description please kindly refer to "REFERENCE NAME LIST".

REF. NO	PART NO.	KANRI NO.	DESCRIPTION	REF. NO	PART NO.	KANRI NO.	DESCRIPTION
IC				C308	87-010-263-080		CAP, ELECT 100-10V
				C315	87-010-374-080		CAP, ELECT 47-10V
	87-A20-446-010	C-IC, LA9241ML		C317	87-010-546-080		CAP, ELECT 0.33-50V
	87-A20-187-010	IC, LC78622E		C318	87-010-546-080		CAP, ELECT 0.33-50V
	87-A20-856-010	IC, BA6898S		C360	87-010-401-080		CAP, ELECT 1-50V
	88-CL5-603-01J	IC, LC867248A-5H31<352EZ, 358EZ>					
	88-CL5-601-01J	IC, LC867248A-5G97<350LH, 350K>		C361	87-010-374-080		CAP, ELECT 47-10V
				C401	87-010-401-080		CAP, ELECT 1-50V
	87-NF8-614-010	IC, SPS-442-1-W		C402	87-010-401-080		CAP, ELECT 1-50V
	87-017-889-010	IC, NJM4558LD		C403	87-010-321-080		CHIP CAPACITOR, 82P(J)
	87-A20-910-010	C-IC, MM1434XF		C404	87-010-321-080		CHIP CAPACITOR, 82P(J)
	87-A20-715-010	IC, M62439SP					
	87-A20-909-010	IC, LA4663		C452	87-010-382-080		CAP, ELECT 22-25V
				C457	87-010-187-080		CAP CHIP S5600P
	87-070-127-110	IC, LC72131 D		C458	87-010-178-080		CHIP CAP 1000P
	87-A20-438-010	IC, LA1837		C459	87-010-175-080		CAP 560P
	87-A20-440-040	C-IC, BU1920FS<352EZ, 358EZ>		C461	87-010-173-080		C-CAP, S 390P-50 SL
				C462	87-010-173-080		C-CAP, S 390P-50 SL
TRANSISTOR				C501	87-010-405-080		CAP, ELECT 10-50V
	87-A30-015-080	TR, 2SA1317TU		C502	87-010-405-080		CAP, ELECT 10-50V
	89-112-965-080	TR, 2SA1296 (0.75W)		C503	87-010-405-080		CAP, ELECT 10-50V
	87-026-610-080	TR, KTC3198GR		C504	87-010-405-080		CAP, ELECT 10-50V
	88-CL5-622-010	TR, 2SB1655E					
	87-026-218-080	TR, DTC144ES (0.2W)		C505	87-010-405-080		CAP, ELECT 10-50V
				C506	87-010-405-080		CAP, ELECT 10-50V
	87-026-237-080	CHIP-TR, DTC124XK		C507	87-010-405-080		CAP, ELECT 10-50V
	87-026-263-080	C-TR, RN1410		C508	87-010-405-080		CAP, ELECT 10-50V
	89-320-011-080	TR, 2SC2001 (15W)		C509	87-010-405-080		CAP, ELECT 10-50V
	89-109-521-080	TR, 2SA952 (0.6W)					
	87-A30-091-080	FET, 2SJ460		C510	87-010-405-080		CAP, ELECT 10-50V
				C513	87-010-545-080		CAP, ELECT 0.22-50V
	87-A30-090-080	FET, 2SK2541		C514	87-010-545-080		CAP, ELECT 0.22-50V
	87-A30-151-080	TR, 2SA1993F		C515	87-010-545-080		CAP, ELECT 0.22-50V
	89-333-317-080	TR, 2SC3331 (0.5W)		C516	87-010-545-080		CAP, ELECT 0.22-50V
	89-322-405-080	TR, 2SC2240GR<EXCEPT 350LH>					
	87-026-219-080	TR, DTA144ES (0.3W)		C517	87-010-762-080		CAP E220-10 BP
				C518	87-010-762-080		CAP E220-10 BP
	87-A30-152-080	TR, 2SC5395F		C519	87-010-401-080		CAP, ELECT 1-50V<EXCEPT 350LH>
	87-A30-196-080	TR, 2SC4115SRS		C520	87-010-401-080		CAP, ELECT 1-50V<EXCEPT 350LH>
	89-327-143-080	TR, 2SC2714 (0.1W)		C521	87-010-401-080		CAP, ELECT 1-50V<EXCEPT 350LH>
	87-A30-072-080	C-TR, RT1P 144C					
	87-026-230-080	TR, DTA114YK		C522	87-010-401-080		CAP, ELECT 1-50V<EXCEPT 350LH>
				C523	87-010-297-080		CAP CHIP 100P
	87-A30-076-080	C-TR, 2SC3052F<352EZ, 358EZ>		C525	87-010-221-080		CAP, ELECT 470-10V<EXCEPT 350LH>
	87-A30-073-080	C-TR, RT1N 141C<352EZ, 358EZ>		C526	87-010-263-080		CAP, ELECT 100-10V<EXCEPT 350LH>
	89-505-434-540	C-FET, 2SK543(4/5)<EXCEPT 350LH>		C526	87-010-112-080		CAP, ELECT 100-16V<350LH>
	87-A30-086-070	C-TR, CSD1306E<EXCEPT 350LH>					
	87-A30-074-080	C-TR, RT1P 141C<EXCEPT 350LH>		C527	87-010-196-080		CHIP CAPACITOR, 0.1-25
				C528	87-010-374-080		CAP, ELECT 47-10V
DIODE				C529	87-010-401-080		CAP, ELECT 1-50V
	87-020-465-080	DIODE, 1SS133 (110MA)		C530	87-010-401-080		CAP, ELECT 1-50V
	87-070-345-080	DIODE, IN4148		C531	87-010-405-080		CAP, ELECT 10-50V
	87-027-825-080	ZENER, HZ9A3L					
	87-A40-304-080	ZENER, DZ6.2M<EXCEPT 350LH>		C532	87-010-402-080		CAP, ELECT 2.2-50V
	87-017-931-080	ZENER, MTZJ5.6B<350LH>		C537	87-010-401-080		CAP, ELECT 1-50V
				C538	87-010-401-080		CAP, ELECT 1-50V
	87-A40-523-080	ZENER, MTZJ9.1B		C539	87-010-401-080		CAP, ELECT 1-50V
	87-070-136-080	ZENER, MTZJ5.1B		C540	87-010-401-080		CAP, ELECT 1-50V
	87-A40-347-080	ZENER, MTZJ2.2B					
	87-A40-345-080	ZENER, MTZJ10C		C541	87-010-404-080		CAP, ELECT 4.7-50V
	87-070-022-010	DIODE, IN5402 (RECT)		C542	87-010-404-080		CAP, ELECT 4.7-50V
				C547	87-010-405-080		CAP, ELECT 10-50V<EXCEPT 350LH>
	87-A40-003-080	ZENER, MTZJ4.3A<350LH>		C547	87-010-404-080		CAP, ELECT 4.7-50V<350LH>
	87-A40-246-080	DIODE, IN4148 T-72		C548	87-010-408-080		CAP, ELECT 47-50V
	87-A40-234-080	ZENER, MTZJ5.6A					
	87-A40-270-080	C-DIODE, MC2838<EXCEPT 350LH>		C549	87-010-405-080		CAP, ELECT 10-50V
				C550	87-010-405-080		CAP, ELECT 10-50V
				C551	87-010-405-080		CAP, ELECT 10-50V
				C552	87-010-405-080		CAP, ELECT 10-50V
				C581	87-010-182-080		C-CAP, S 2200P-50 B
MAIN C.B							
				C582	87-010-182-080		C-CAP, S 2200P-50 B
				C583	87-010-174-080		CAP CHIP SL470P (K)<EXCEPT 350LH>
				C583	87-010-186-080		CAP, CHIP 4700P<350LH>
				C584	87-010-174-080		CAP CHIP SL470P (K)<EXCEPT 350LH>
				C584	87-010-186-080		CAP, CHIP 4700P<350LH>
				C618	87-010-174-080		CAP CHIP SL470P (K)
				C619	87-010-408-080		CAP, ELECT 47-50V
				C620	87-010-384-080		CAP, ELECT 100-25V
				C621	87-010-381-080		CAP, ELECT 330-16V
				C650	87-010-197-080		CAP, CHIP 0.01 DM

REF. NO	PART NO.	KANRI NO.	DESCRIPTION	REF. NO	PART NO.	KANRI NO.	DESCRIPTION
C651	87-010-198-080		CAP, CHIP 0.022	C828	87-010-196-080		CHIP CAPACITOR, 0.1-25
C652	87-010-198-080		CAP, CHIP 0.022	C829	87-010-196-080		CHIP CAPACITOR, 0.1-25
C653	87-010-198-080		CAP, CHIP 0.022	C859	87-010-197-080		CAP, CHIP 0.01 DM<352EZ, 358EZ>
C654	87-010-198-080		CAP, CHIP 0.022	C861	87-012-156-080		C-CAP, S 220P-50 CH<352EZ, 358EZ>
C655	87-010-453-090		CAP ELECT 4700-25V SME	C862	87-012-156-080		C-CAP, S 220P-50 CH<352EZ, 358EZ>
C661	87-010-263-080		CAP, ELECT 100-10V	C863	87-012-140-080		CAP 470P<352EZ, 358EZ>
C662	87-010-403-080		CAP, ELECT 3.3-50V	C864	87-010-405-080		CAP, ELECT 10-50V<352EZ, 358EZ>
C665	87-010-197-080		CAP, CHIP 0.01 DM<352EZ, 358EZ>	C865	87-010-197-080		CAP, CHIP 0.01 DM<352EZ, 358EZ>
C666	87-010-197-080		CAP, CHIP 0.01 DM<352EZ, 358EZ>	C866	87-010-405-080		CAP, ELECT 10-50V<352EZ, 358EZ>
C667	87-010-197-080		CAP, CHIP 0.01 DM<352EZ, 358EZ>	C867	87-010-197-080		CAP, CHIP 0.01 DM<352EZ, 358EZ>
C668	87-010-197-080		CAP, CHIP 0.01 DM<352EZ, 358EZ>	C868	87-010-316-080		C-CAP, S 33P-50 CH<352EZ, 358EZ>
C701	87-010-381-080		CAP, ELECT 330-16V	C869	87-010-314-080		C-CAP, S 22P-50V<352EZ, 358EZ>
C702	87-010-404-080		CAP, ELECT 4.7-50V	C940	87-010-197-080		CAP, CHIP 0.01 DM<EXCEPT 350LH>
C703	87-010-197-080		CAP, CHIP 0.01 DM	C942	87-010-151-080		C-CAP, S 7P-50 CH<EXCEPT 350LH>
C704	87-010-197-080		CAP, CHIP 0.01 DM	C947	87-010-197-080		CAP, CHIP 0.01 DM<EXCEPT 350LH>
C711	87-010-263-080		CAP, ELECT 100-10V	C949	87-014-049-080		CAP, PP 470P-100 J<EXCEPT 350LH>
C712	87-010-196-080		CHIP CAPACITOR, 0.1-25	C952	87-010-197-080		CAP, CHIP 0.01 DM<EXCEPT 350LH>
C713	87-010-197-080		CAP, CHIP 0.01 DM	C957	87-010-311-080		CAP 12P<EXCEPT 350LH>
C714	87-010-197-080		CAP, CHIP 0.01 DM	C958	87-010-197-080		CAP, CHIP 0.01 DM<EXCEPT 350LH>
C718	87-010-297-080		C-CAP, S 100P-50	C959	87-010-196-080		CHIP CAPACITOR, 0.1-25
C721	87-010-312-080		C-CAP, S 15P-50 CH	C960	87-010-196-080		CHIP CAPACITOR, 0.1-25
C722	87-010-312-080		C-CAP, S 15P-50 CH	C961	87-010-152-080		C-CAP, S 8P-50 CH<350LH>
C723	87-010-178-080		CHIP CAP 1000P	C962	87-010-401-080		CAP, ELECT 1-50V<EXCEPT 350LH>
C725	87-010-178-080		CHIP CAP 1000P	CF801	87-008-261-010		FILTER, SFE10.7MA5-A<350LH>
C727	87-010-196-080		CHIP CAPACITOR, 0.1-25	CF801	87-008-423-010		CERAMIC FILTER, SFE10.7 <EXCEPT 350LH>
C728	87-010-248-080		CAP, ELECT 220-10V	CF802	87-008-261-010		FILTER, SFE10.7MA5-A<350LH>
C740	87-010-197-080		CAP, CHIP 0.01 DM	CF802	82-785-747-010		CF MS2 GHY R<EXCEPT 350LH>
C756	87-010-197-080		CAP, CHIP 0.01 DM	AF651	87-035-192-010		FUSE, 4AT
C757	87-010-318-080		C-CAP, S 47P-50 CH	FB601	87-003-216-080		F-BEAD, BLO1RM1
C758	87-010-149-080		C-CAP, S 5P-50 CH	FB602	87-003-216-080		F-BEAD, BLO1RM1
C762	87-010-197-080		CAP, CHIP 0.01 DM	FB603	87-003-216-080		F-BEAD, BLO1RM1
C763	87-010-194-080		CAP, CHIP 0.047	FB604	87-003-216-080		F-BEAD, BLO1RM1
C764	87-010-319-080		C-CAP, S 56P-50 CH<350LH, 350K>	AFE801	A8-8ZA-193-070		8ZA-1 YFEUNC<350LH, 350K>
C765	87-010-197-080		CAP, CHIP 0.01 DM	AFE801	A8-6ZA-19C-170		6ZA-1 YFEENC<352EZ, 358EZ>
C767	87-010-405-080		CAP, ELECT 10-50V	J601	88-CL5-609-010		TERMINAL, SP 4P
C768	87-010-197-080		CAP, CHIP 0.01 DM	J602	88-CL5-608-010		JACK, 3.6 S W/SW
C769	87-010-408-080		CAP, ELECT 47-50V	J603	88-CL5-607-010		JACK, PIN 2P
C770	87-010-194-080		CAP, CHIP 0.047	J651	87-099-608-010		JACK, DC HEC3800
C771	87-010-407-080		CAP, ELECT 33-50V	J801	87-033-239-010		TERMINAL, HSP-154V-2<350LH>
C772	87-010-194-080		CAP, CHIP 0.047	J801	87-033-241-010		TERMINAL, ANT AJ-2039 <EXCEPT 350LH>
C773	87-010-196-080		CHIP CAPACITOR, 0.1-25	L451	87-007-342-010		COIL, OSC 85K BIAS
C774	87-010-263-080		CAP, ELECT 100-10V	L601	87-005-366-010		COIL, 1UH<352EZ, 358EZ>
C775	87-010-404-080		CAP, ELECT 4.7-50V	L602	87-005-366-010		COIL, 1UH<352EZ, 358EZ>
C776	87-010-197-080		CAP, CHIP 0.01 DM	L603	87-005-366-010		COIL, 1UH<352EZ, 358EZ>
C777	87-010-400-080		CAP, ELECT 0.47-50V	L604	87-005-366-010		COIL, 1UH<352EZ, 358EZ>
C778	87-010-401-080		CAP, ELECT 1-50V	L771	87-A50-266-010		COIL, FM DET-2N(TOK)
C779	87-010-401-080		CAP, ELECT 1-50V	L773	87-A90-733-010		FLTR, PCFAZH-450 (TOK)
C780	87-010-196-080		CHIP CAPACITOR, 0.1-25	L781	87-005-847-080		COIL, 2.2UH(CECS)
C781	87-010-405-080		CAP, ELECT 10-50V	L832	87-005-847-080		COIL, 2.2UH(CECS)
C782	87-010-405-080		CAP, ELECT 10-50V	L851	87-005-847-080		COIL, 2.2UH(CECS)<352EZ, 358EZ>
C783	87-010-197-080		CAP, CHIP 0.01 DM	L941	87-A50-020-010		COIL, ANT LW(COI)<EXCEPT 350LH>
C784	87-010-197-080		CAP, CHIP 0.01 DM	L942	87-A50-019-010		COIL, OSC LW(COI)<EXCEPT 350LH>
C785	87-010-403-080		CAP, ELECT 3.3-50V	L982	87-NF4-650-010		COIL, AM PACK 4N(TOK)<350LH>
C786	87-010-403-080		CAP, ELECT 3.3-50V	L982	87-NF4-651-010		COIL, AM PACK2N(TOM)<EXCEPT 350LH>
C789	87-010-186-080		CAP, CHIP 4700P	R561	87-025-329-080		RESISTOR, 1/4W 2.2
C790	87-010-186-080		CAP, CHIP 4700P	R562	87-025-329-080		RESISTOR, 1/4W 2.2
C791	87-010-405-080		CAP, ELECT 10-50V	R567	87-025-329-080		RESISTOR, 1/4W 2.2
C793	87-010-177-080		C-CAP, S 820P-50 SL	R568	87-025-329-080		RESISTOR, 1/4W 2.2
C794	87-010-406-080		CAP, ELECT 22-50	TC942	87-011-221-080		CAP, TRIMMER 30P<EXCEPT 350LH>
C795	87-010-596-080		CAP, S 0.047-16	X721	87-A70-061-010		VIB, XTAL 4.500MHZ CSA-309
C796	87-010-403-080		CAP, ELECT 3.3-50V	X851	87-A70-091-010		VIB, XTAL 4.332MHZ CSA-309 <352EZ, 358EZ>
C797	87-010-182-080		C-CAP, S 2200P-50 B				
C798	87-010-182-080		C-CAP, S 2200P-50 B				
C799	87-010-194-080		CAP, CHIP 0.047				
C812	87-010-197-080		CAP, CHIP 0.01 DM				
C814	87-010-197-080		CAP, CHIP 0.01 DM				
C820	87-010-408-080		CAP, ELECT 47-50V				
C821	87-010-197-080		CAP, CHIP 0.01 DM				
C822	87-010-197-080		CAP, CHIP 0.01 DM				
C823	87-010-197-080		CAP, CHIP 0.01 DM				
				FRONT C.B			
				C201	87-010-263-080		CAP, ELECT 100-10V
				C202	87-010-370-040		CAP, E 330-6.3 SME
				C203	87-010-197-080		CAP, CHIP 0.01 DM

REF. NO	PART NO.	KANRI NO.	DESCRIPTION	REF. NO	PART NO.	KANRI NO.	DESCRIPTION
C204	87-010-196-080		CHIP CAPACITOR, 0.1-25	C145	87-010-196-080		CHIP CAPACITOR, 0.1-25
C208	87-010-197-080		CAP, CHIP 0.01 DM	C146	87-010-101-080		CAP, ELECT 220-16
C210	87-010-196-080		CHIP CAPACITOR, 0.1-25	C148	87-010-314-080		C-CAP, S 22P-50V
C211	87-010-400-080		CAP, ELECT 0.47-50V	C149	88-700-910-810		CAP, M 0.1-50 J
C212	87-010-312-080		C-CAP, S 15P-50 CH	C150	87-010-314-080		C-CAP, S 22P-50V
C213	87-010-320-080		CHIP CAP 68P	C151	87-010-263-080		CAP, ELECT 100-10V
C214	87-010-316-080		C-CAP, S 33P-50 CH	C153	87-010-196-080		CHIP CAPACITOR, 0.1-25
C215	87-010-312-080		C-CAP, S 15P-50 CH	C154	87-010-196-080		CHIP CAPACITOR, 0.1-25
C216	87-010-314-080		C-CAP, S 22P-50V	C155	87-010-196-080		CHIP CAPACITOR, 0.1-25
C217	87-010-401-080		CAP, ELECT 1-50V	C156	87-010-196-080		CHIP CAPACITOR, 0.1-25
C218	87-010-197-080		CAP, CHIP 0.01 DM	C157	87-010-196-080		CHIP CAPACITOR, 0.1-25
C219	87-010-263-080		CAP, ELECT 100-10V	C158	87-010-263-080		CAP, ELECT 100-10V
CN204	88-CL5-621-010		CONN ASSY, 9P V DECK	C159	87-010-196-080		CHIP CAPACITOR, 0.1-25
L201	87-005-847-080		COIL, 2.2UH (CECS)	C160	87-010-221-080		CAP, ELECT 470-10V
L202	87-005-847-080		COIL, 2.2UH (CECS)	C161	87-010-196-080		CHIP CAPACITOR, 0.1-25
LCD201	88-CL5-605-010		LCD, AIW4124-30PIN	C164	87-010-405-080		CAP, ELECT 10-50V
S201	87-A90-770-080		SW, TACT TRT134-L4.3	C165	87-010-405-080		CAP, ELECT 10-50V
S202	87-A90-770-080		SW, TACT TRT134-L4.3	C166	87-012-154-080		C-CAP, S 150P-50 CH
S203	87-A90-770-080		SW, TACT TRT134-L4.3	C167	87-010-380-080		CAP, ELECT 47-16V<350LH>
S204	87-A90-770-080		SW, TACT TRT134-L4.3	C170	87-010-404-080		CAP, ELECT 4.7-50V
S205	87-A90-770-080		SW, TACT TRT134-L4.3	C172	87-010-182-080		C-CAP, S 2200P-50 B<350LH>
S206	87-A90-770-080		SW, TACT TRT134-L4.3	C173	87-010-182-080		C-CAP, S 2200P-50 B<350LH>
S207	87-A90-770-080		SW, TACT TRT134-L4.3	C175	87-010-404-080		CAP, ELECT 4.7-50V
S208	87-A90-770-080		SW, TACT TRT134-L4.3	C176	88-700-780-810		CAP, M 0.33-50 J LDS
S209	87-A90-770-080		SW, TACT TRT134-L4.3	C177	87-010-178-080		C-CAP, S 1000P-50 K B
S210	87-A90-770-080		SW, TACT TRT134-L4.3	C178	87-010-178-080		C-CAP, S 1000P-50 K B
S211	87-A90-770-080		SW, TACT TRT134-L4.3	C181	87-010-198-080		CAP, CHIP 0.022
S211	87-A90-770-080		SW, TACT TRT134-L4.3	C182	87-010-263-080		CAP, ELECT 100-10V
S212	87-A90-770-080		SW, TACT TRT134-L4.3	C183	87-010-197-080		CAP, CHIP 0.01 DM
S213	87-A90-770-080		SW, TACT TRT134-L4.3	C184	87-010-380-080		CAP, ELECT 47-16V
S214	87-A90-770-080		SW, TACT TRT134-L4.3	C191	87-012-365-080		C-CAP, S 0.027-25VBEK
S214	87-A90-770-080		SW, TACT TRT134-L4.3	C192	87-010-401-080		CAP, ELECT 1-50V
S215	87-A90-770-080		SW, TACT TRT134-L4.3	C194	87-010-196-080		CHIP CAPACITOR, 0.1-25
S216	87-A90-770-080		SW, TACT TRT134-L4.3	CN102	88-CL5-610-010		CONN ASSY, 6P V
S217	87-A90-770-080		SW, TACT TRT134-L4.3	FB101	87-003-216-080		F-BEAD, BLO1RM1
S218	87-A90-770-080		SW, TACT TRT134-L4.3	FB102	87-003-216-080		F-BEAD, BLO1RM1
S219	87-A90-770-080		SW, TACT TRT134-L4.3	L113	87-005-847-080		COIL, 2.2UH (CECS)
X201	87-030-194-080		XTAL 32.768KHZ	L115	87-005-847-080		COIL, 2.2UH (CECS)
X202	87-A70-070-080		VIB, CER 5.76MHZ CRHF	R150	87-029-370-010		RES, FUSE 2.2-1/2W
				W101	88-CL5-611-010		PF-CABLE, 16P 1.0
CD C.B				X101	81-592-641-010		CERAMIC FILTER, 16.93MHZ
C101	87-010-406-080		CAP, ELECT 22-50				
C102	87-010-178-080		CHIP CAP 1000P	LED C.B			
C109	87-010-180-080		C-CAP 1500P-50B	D945	87-CL5-602-010		LED, SLR342-MG3F
C110	87-010-401-080		CAP, ELECT 1-50V	D946	87-CL5-602-010		LED, SLR342-MG3F
C113	87-010-263-080		CAP, ELECT 100-10V	D946	87-CL5-602-010		LED, SLR342-MG3F
C114	87-010-176-080		C-CAP, S 680P-50 SL	D947	87-CL5-602-010		LED, SLR342-MG3F
C116	87-010-178-080		CHIP CAP 1000P	D948	87-CL5-602-010		LED, SLR342-MG3F
C117	87-012-140-080		CAP 470P				
C118	87-010-545-080		CAP, M 0.22-50 J	D949	87-CL5-602-010		LED, SLR342-MG3F
C120	87-010-406-080		CAP, ELECT 22-50	D950	87-CL5-602-010		LED, SLR342-MG3F
C121	87-010-403-080		CAP, ELECT 3.3-50V	D951	87-CL5-602-010		LED, SLR342-MG3F
C122	87-010-186-080		CAP, CHIP 4700P	D952	87-CL5-602-010		LED, SLR342-MG3F
C123	87-010-147-080		C-CAP, S 3P-50 CH	D953	87-CL5-602-010		LED, SLR342-MG3F
C125	87-010-236-080		CAP, E 1000-10 SME				
C126	87-010-313-080		CAP, CHIP 18P	AC C.B			
C128	87-010-178-080		CHIP CAP 1000P				
C129	87-010-380-080		CAP, ELECT 47-16V	MOTOR C.B			
C130	87-010-197-080		CAP, CHIP 0.01 DM	M2	9X-262-513-210		SLED MOTOR ASSY
C131	87-010-263-080		CAP, ELECT 100-10V	PIN3	91-564-722-110		CONNECTOR 6P
C132	87-010-405-080		CAP, ELECT 10-50V	SW1	91-572-085-110		LEAF SW
C133	87-010-401-080		CAP, ELECT 1-50V				
C134	87-010-197-080		CAP, CHIP 0.01 DM	DECK C.B			
C136	87-010-263-080		CAP, ELECT 100-10V	CN1	87-009-352-019		CONN, 9P H WHT PH
C137	87-010-198-080		CAP, CHIP 0.022	SFR1	87-024-581-019		SFR, 3.3K H KVSP637A
C138	87-010-762-080		CAP E220-10 BP	SOL1	82-ZM1-634-010		SOL ASSY, 23K
C139	87-010-197-080		CAP, CHIP 0.01 DM	SW2	87-A90-248-019		SW, MICRO ESE11SH2CXQ
C140	87-010-380-080		CAP, ELECT 47-16V	SW3	87-A90-248-019		SW, MICRO ESE11SH2CXQ
C141	87-010-196-080		CHIP CAPACITOR, 0.1-25				

REF. NO	PART NO.	KANRI NO.	DESCRIPTION	REF. NO	PART NO.	KANRI NO.	DESCRIPTION
SW5	87-A90-248-019	SW, MICRO	ESE11SH2CXQ	RELAY C.B			
SW6	87-A90-248-019	SW, MICRO	ESE11SH2CXQ	CN351	88-CL5-613-010		CONN ASSY, 8P RPEH

- コネクタについては、初回発注の扱いとはせず、受注後に業者へ発注し、供給致します。
- Regarding connectors, they are not stocked as they are not the initial order items.
The connectors are available after they are supplied from connector manufacturers upon the order is received.

○ チップ抵抗部品コード / CHIP RESISTOR PART CODE

チップ抵抗部品コードの成り立ち
Chip Resistor Part Coding

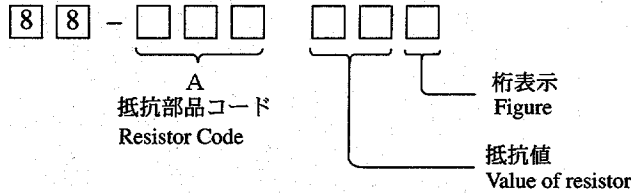

チップ抵抗
Chip resistor

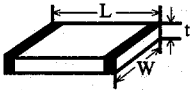
容量 Wattage	種類 Type	許容誤差 Tolerance	記号 Symbol	寸法 / Dimensions (mm)			抵抗コード : A Resistor Code : A	
				外形 / Form	L	W		t
1/16W	1608	5%	CJ		1.6	0.8	0.45	108
1/10W	2125	5%	CJ		2	1.25	0.45	118
1/8W	3216	5%	CJ		3.2	1.6	0.55	128

TRANSISTOR ILLUSTRATION



ECB
2SA952
2SC2001

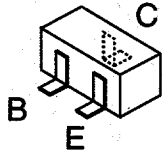

2SA1037
2SC2714
2SC3052
CSD1306
DTA114YK
DTA143EK
DTC124XK
RT1N141C
RT1P144C
RN1410



ECB
2SA1296
KTC3198



BCE
2SA1317
2SB1655



ECB
2SA1993
2SC4115
2SC5395
DTA144ES
DTC144ES



ECB
2SC2240
2SC3331



DSG
2SJ460
2SK2541

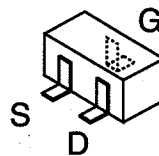

2SK543

1 2 3 4 5 6 7 8 9 10 11 12 13 14

A
B
C
D
E
F
G
H
I
J

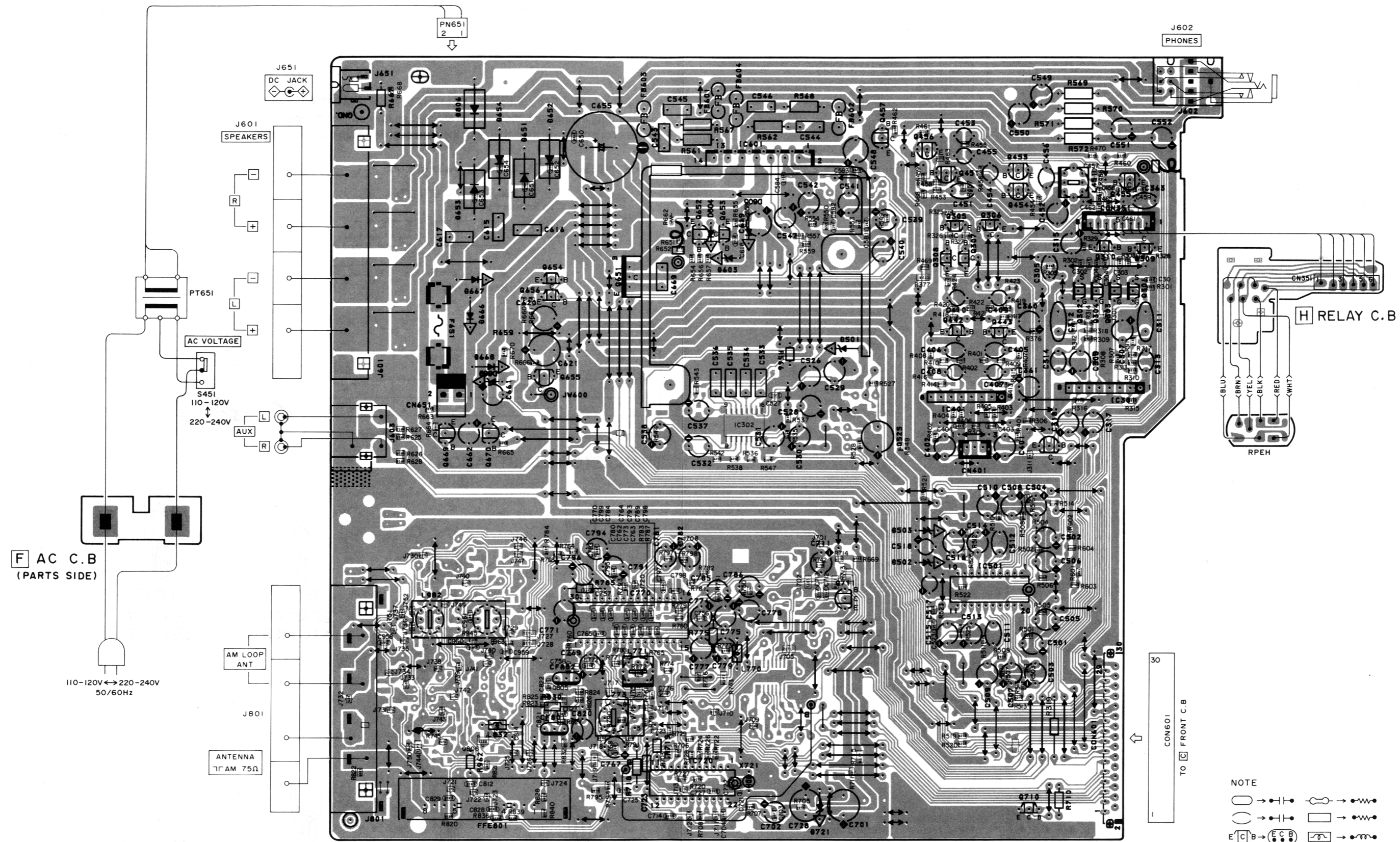

A MAIN C.B (PARTS SIDE)

F AC C.B (PARTS SIDE)

H RELAY C.B

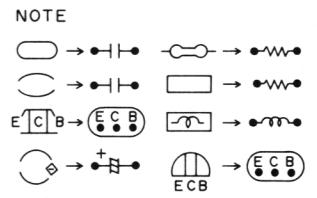

30
TO FRONT C.B

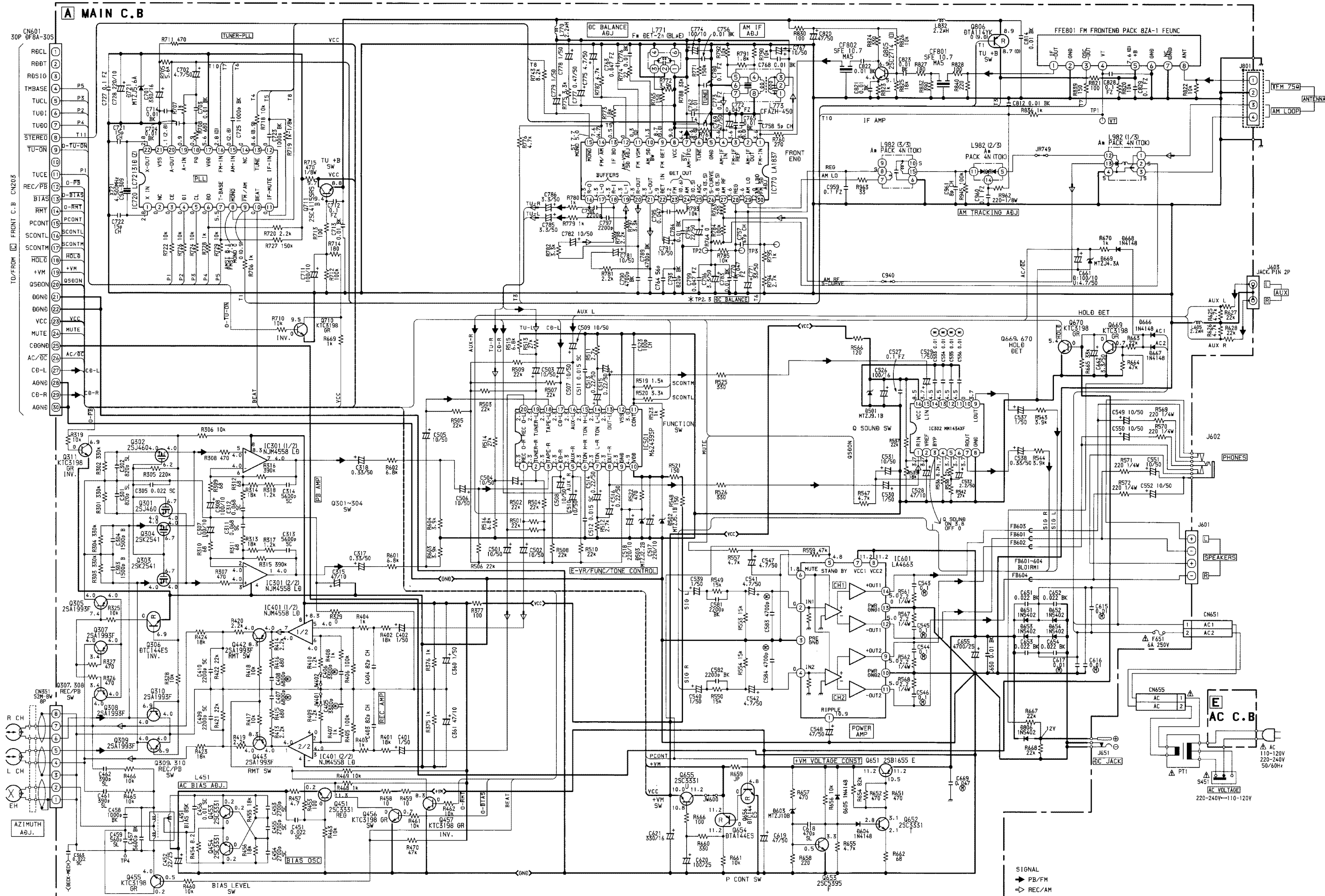

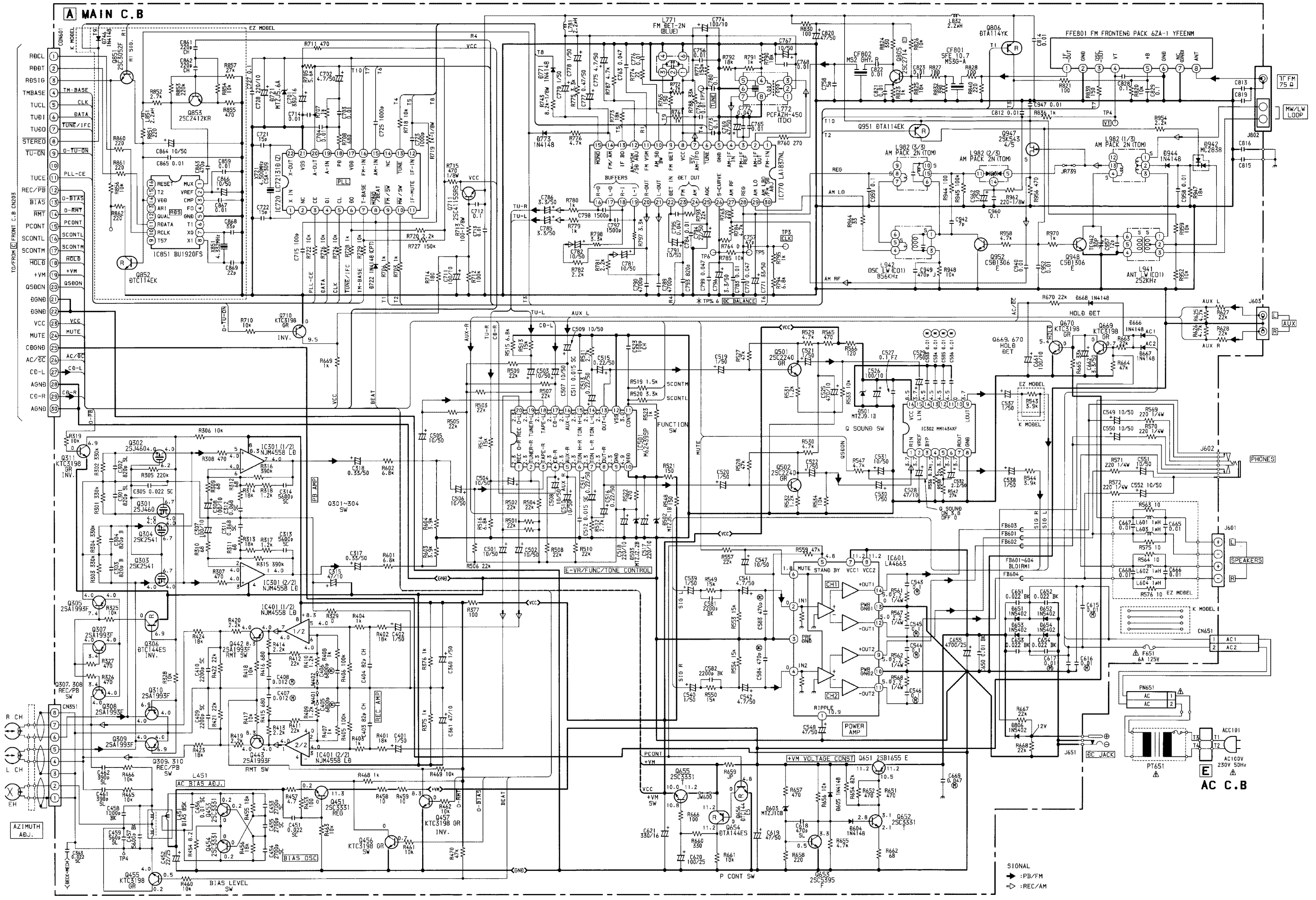

TOP FROM FRONT C.B. CN205

AZIMUTH ADJ.

BIAS LEVEL SW

BIAS DSC

REC/PB SW

A
B
C
D
E
F
G
H
I
J

F AC C.B
(PARTS SIDE)

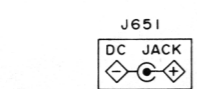
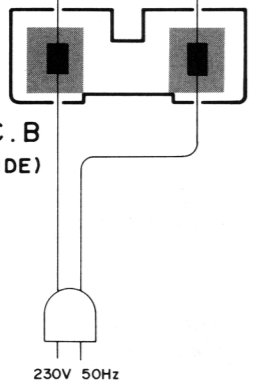

J601 SPEAKERS

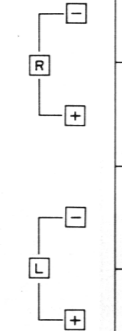

AUX



MW/LW LOOP

ANTENNA
75Ω FM 75Ω

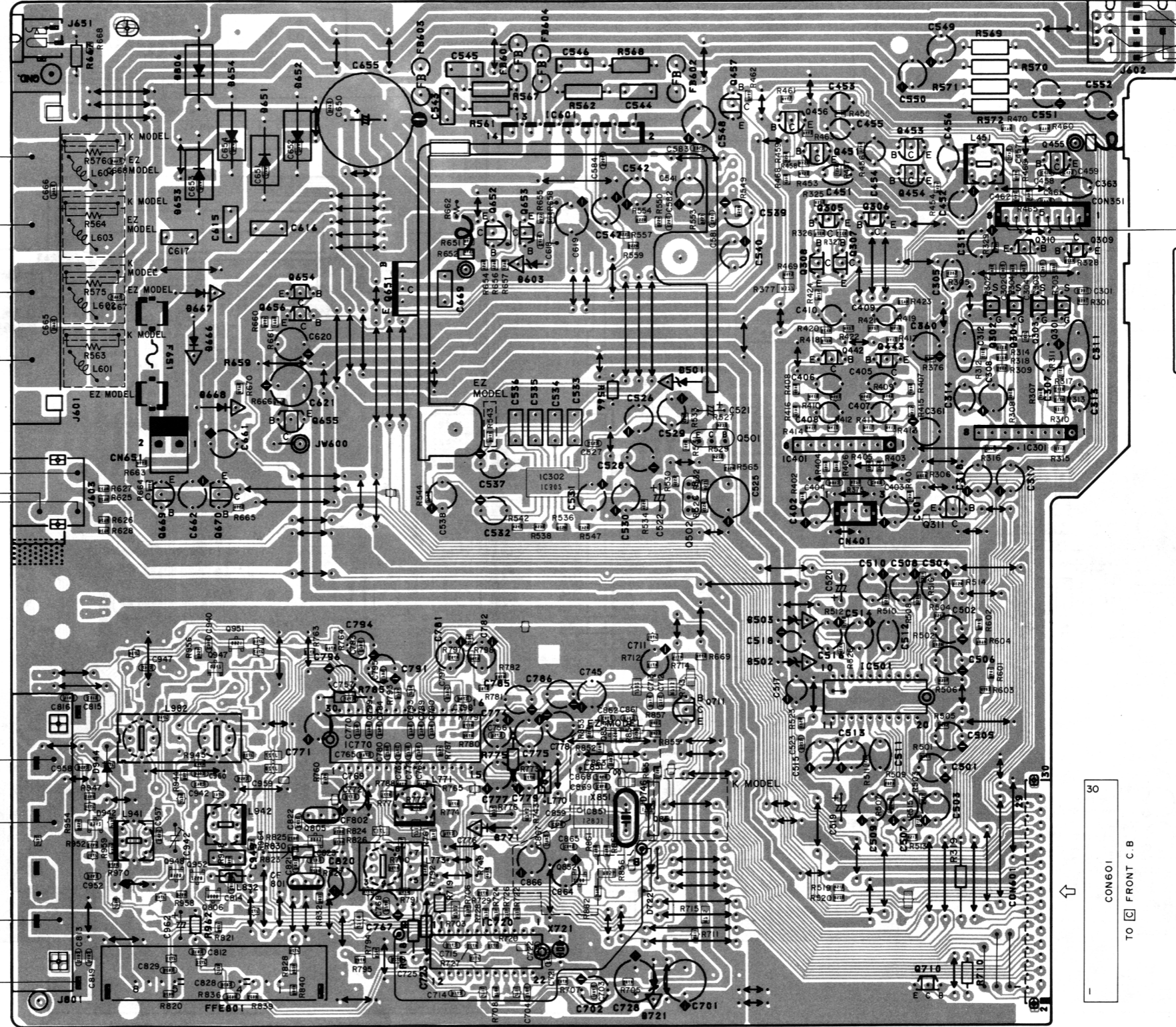

J602 PHONES

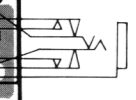

H RELAY C.B

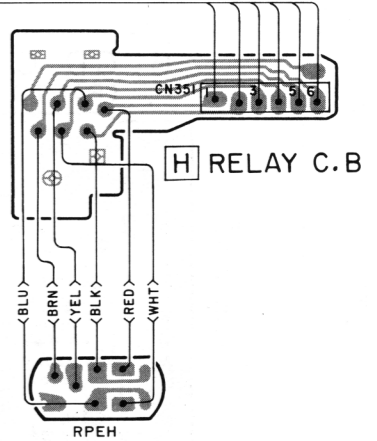

30
CON601
TO FRONT C.B

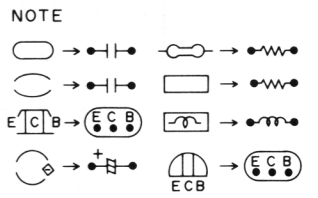

A MAIN C.B (PARTS SIDE)

1 2 3 4 5 6 7 8 9 10 11 12 13 14

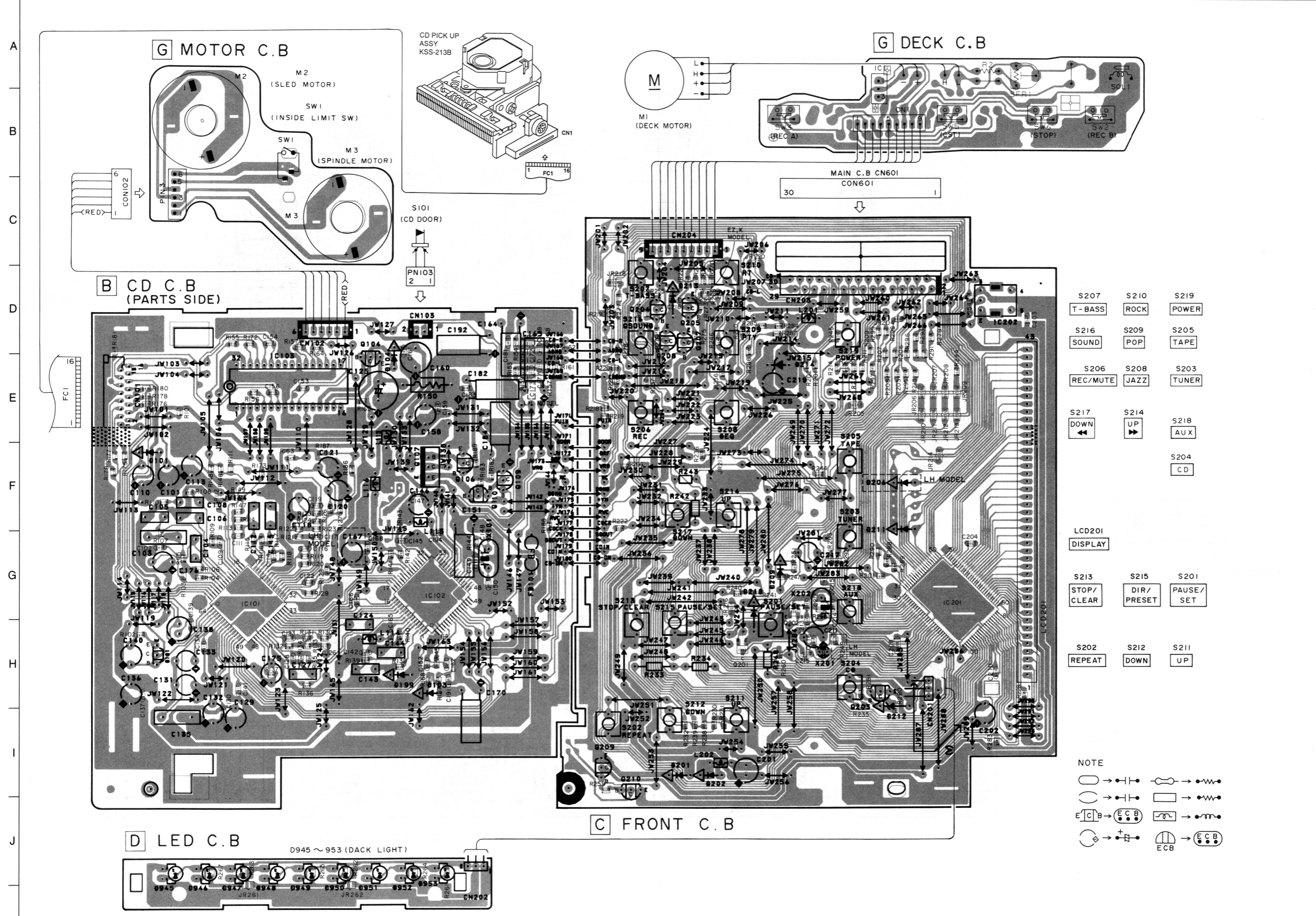

G MOTOR C.B

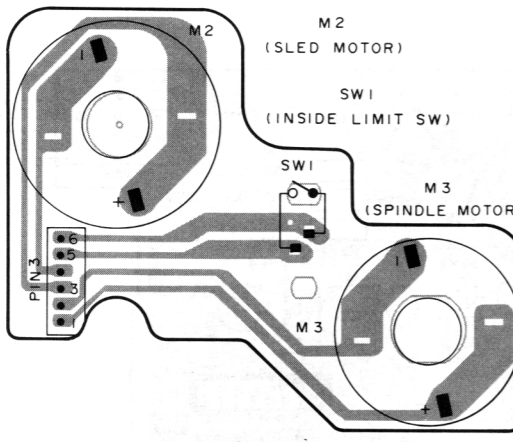

CD PICK UP ASSY KSS-213B

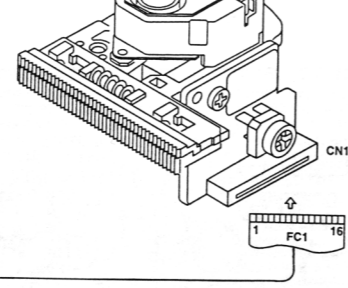

G DECK C.B

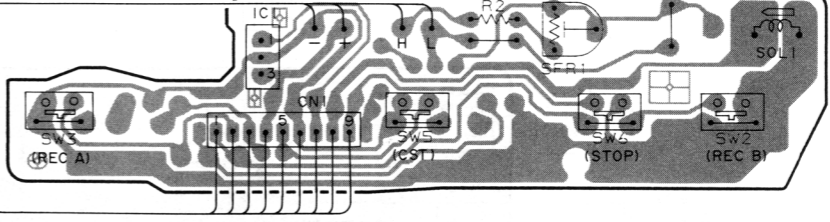

B CD C.B (PARTS SIDE)

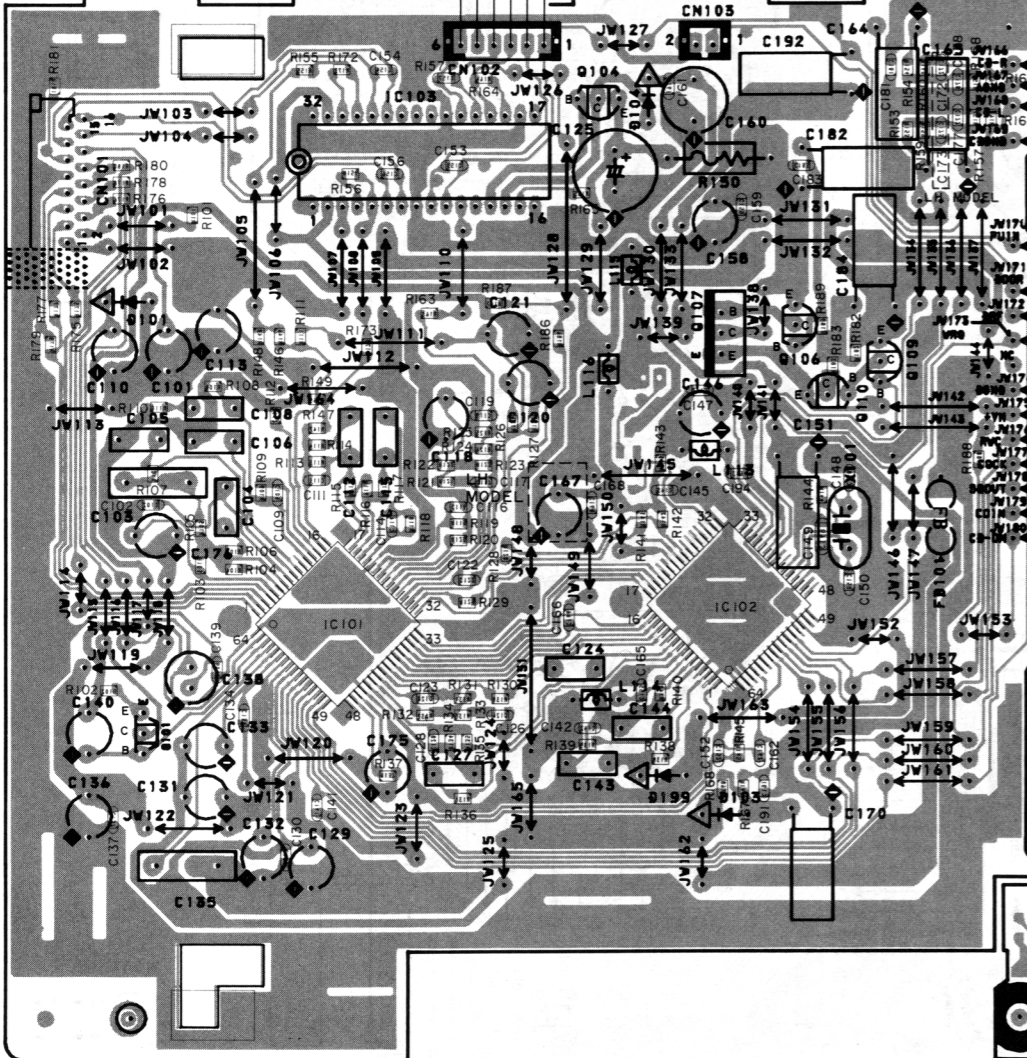

D LED C.B

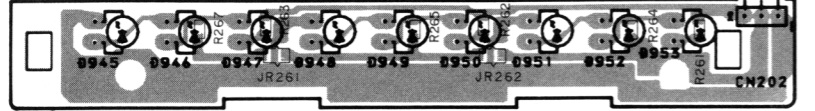

C FRONT C.B

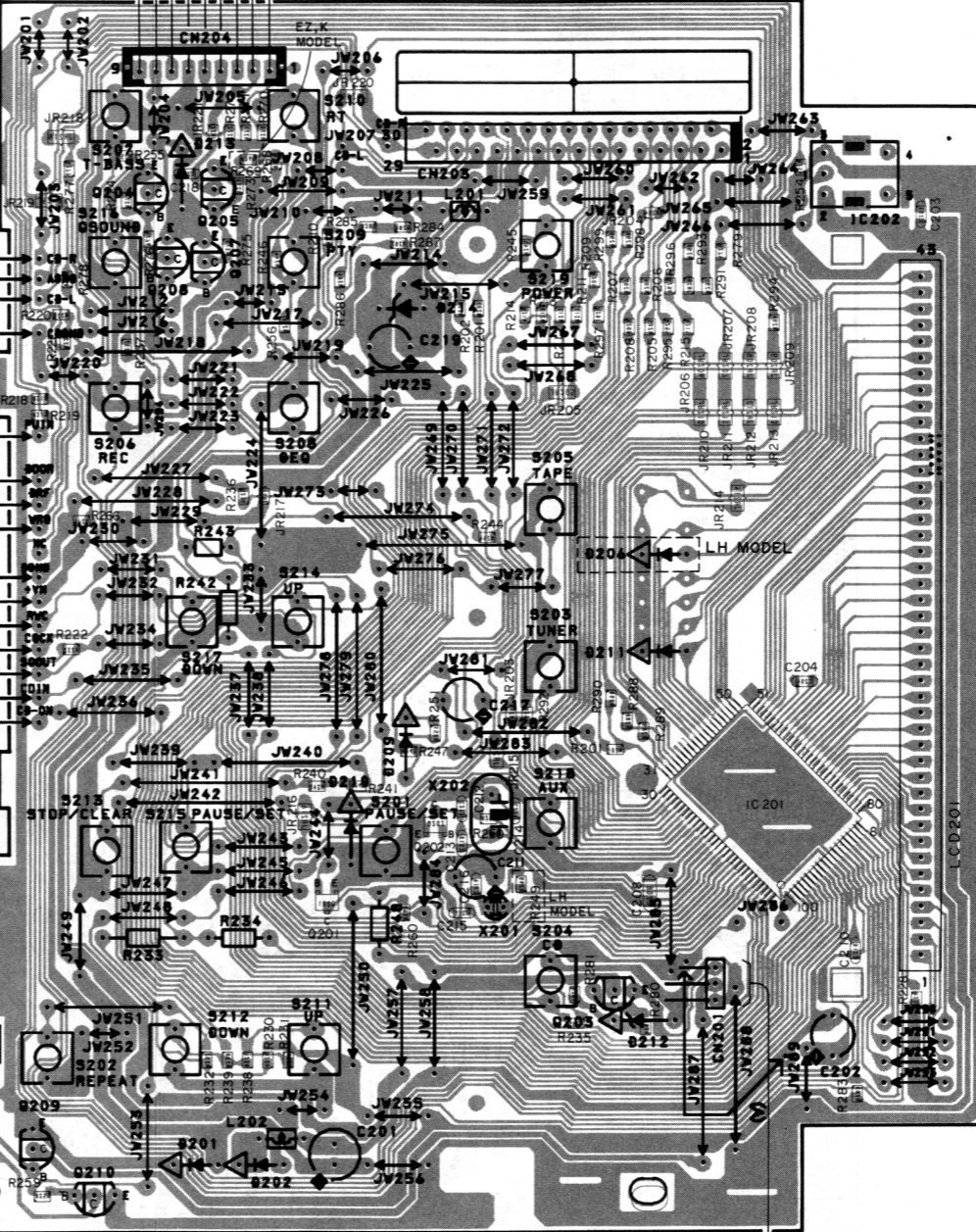

- | | | |
|------------|------------|-----------|
| S207 | S210 | S219 |
| T-BASS | ROCK | POWER |
| S216 | S209 | S205 |
| SOUND | POP | TAPE |
| S206 | S208 | S203 |
| REC/MUTE | JAZZ | TUNER |
| S217 | S214 | S218 |
| DOWN | UP | AUX |
| | | S204 |
| | | CD |
| LCD201 | | |
| DISPLAY | | |
| S213 | S215 | S201 |
| STOP/CLEAR | DIR/PRESET | PAUSE/SET |
| S202 | S212 | S211 |
| REPEAT | DOWN | UP |

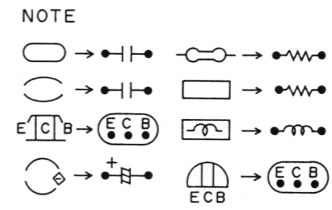

SCHEMATIC DIAGRAM-3 (FRONT)

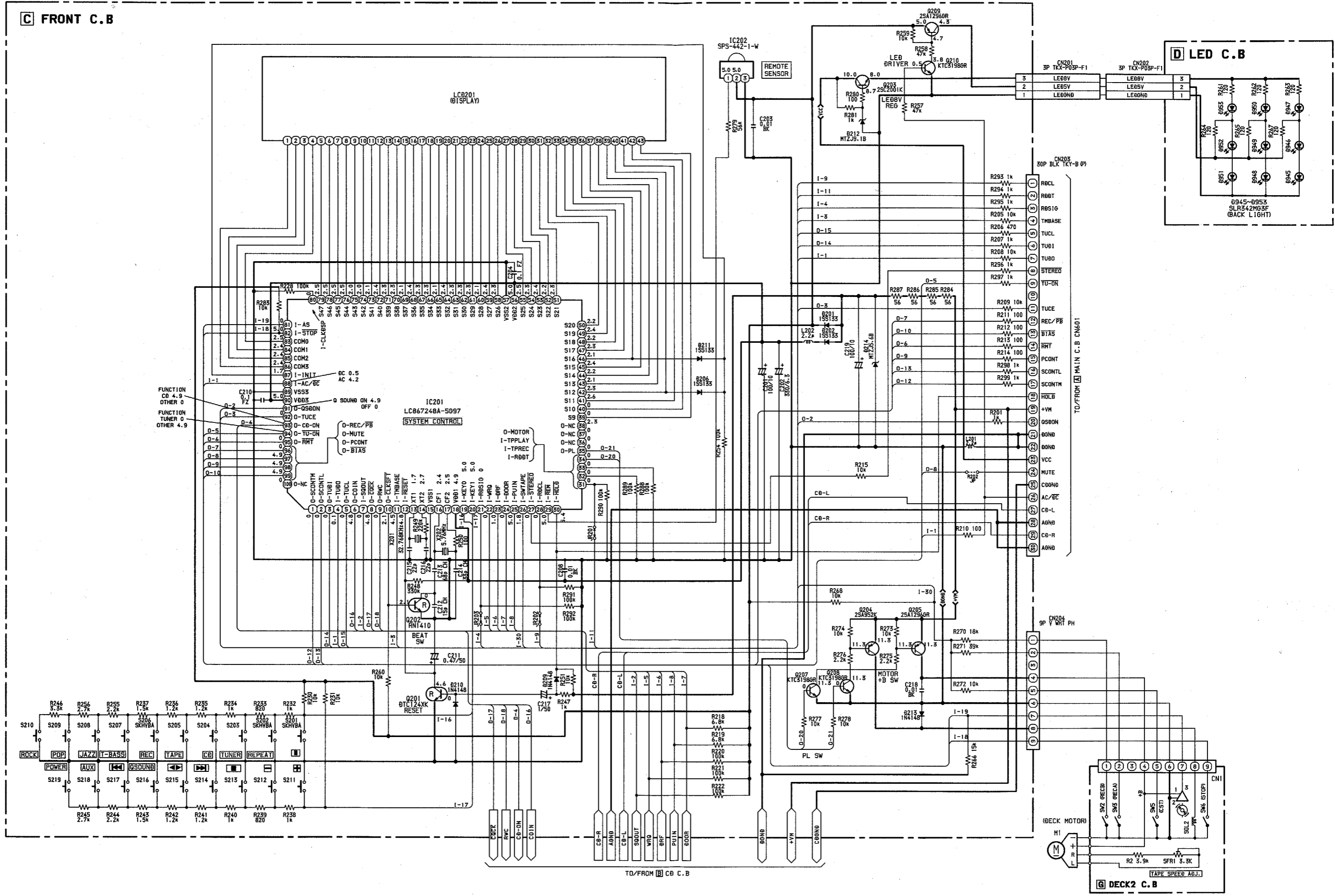

C FRONT C.B

D LED C.B

E DECK2 C.B

IC BLOCK DIAGRAM

IC, BA6898S

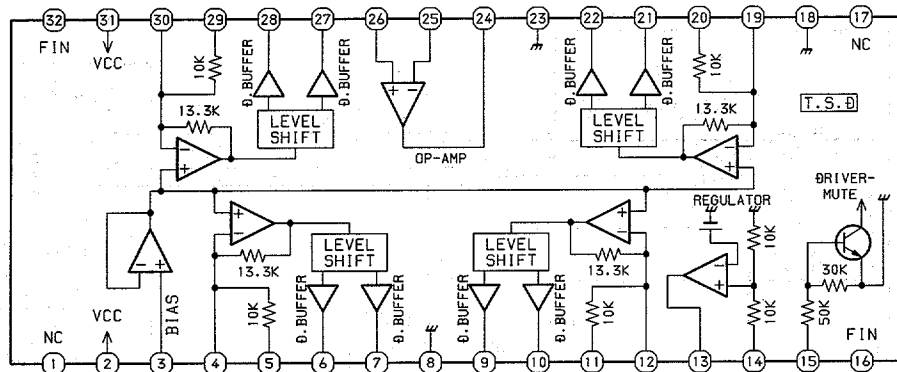

T.S.Ø: Thermal shift down circuit
Ø.BUFFER: Drive Buffer

IC, MM1434XF

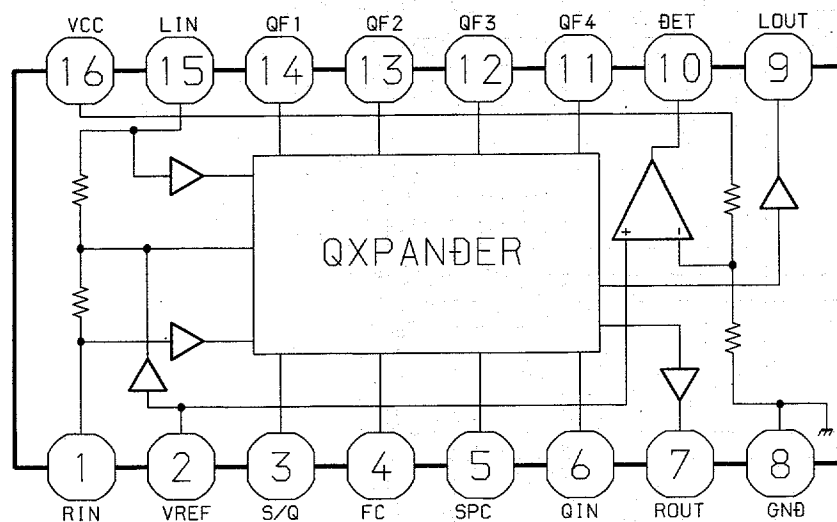

IC, LC72131

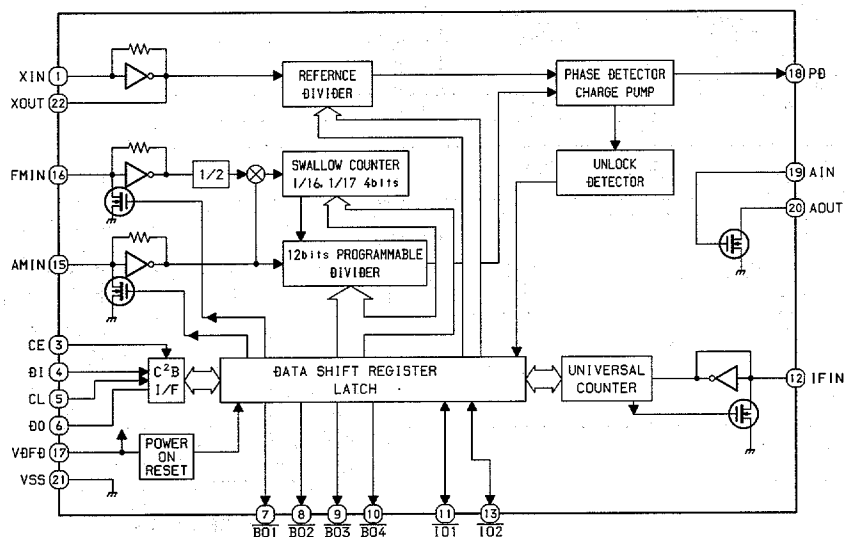

IC, LA1837

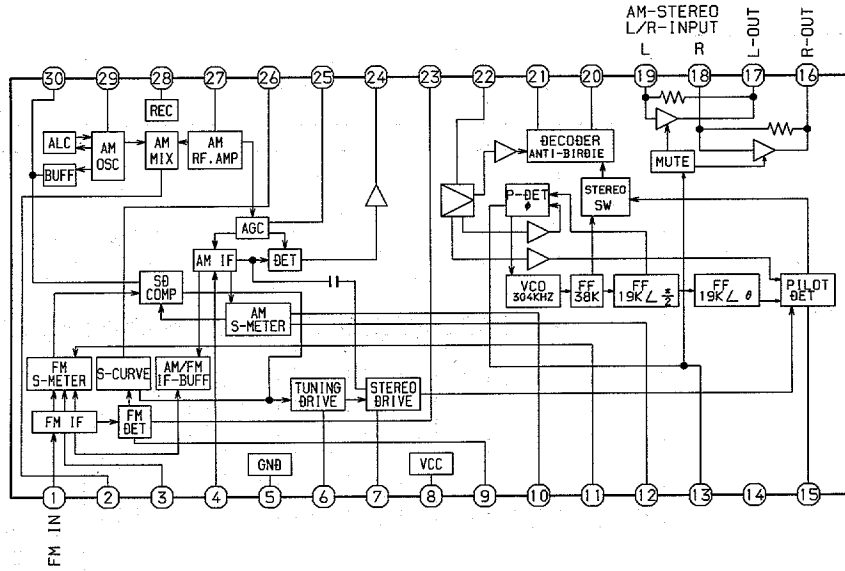

IC, M62439SP

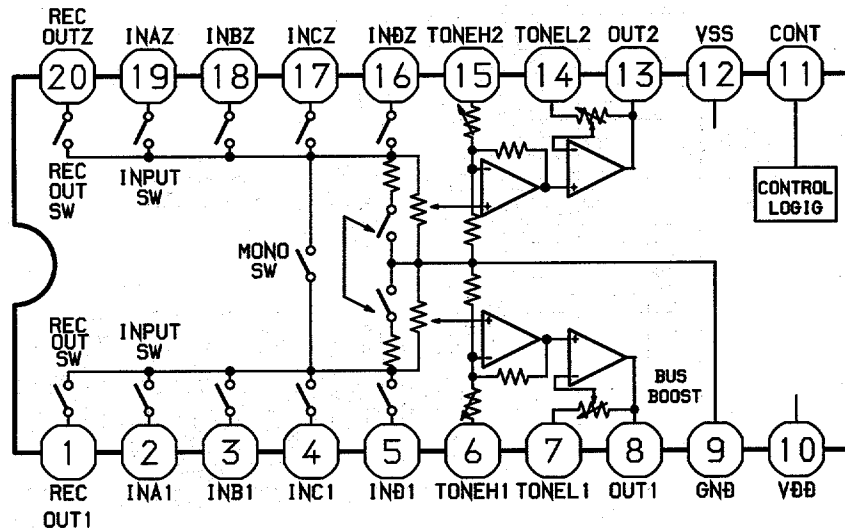

IC, BU1920FS

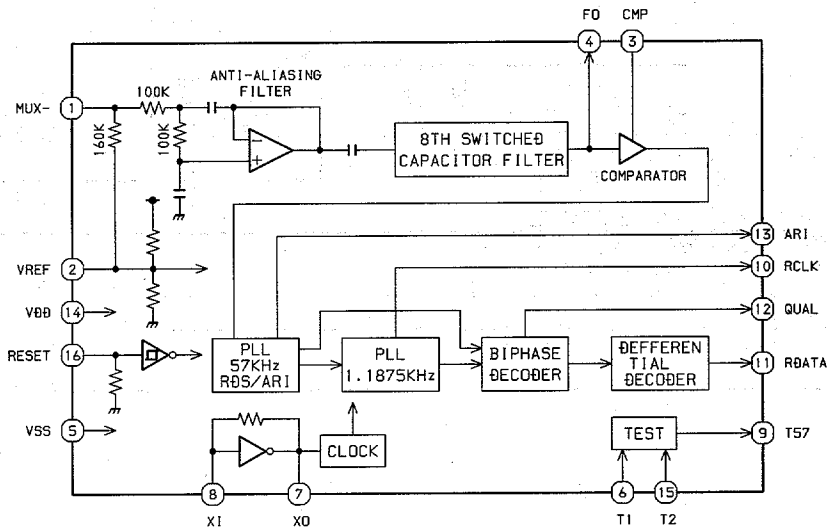

SCHEMATIC DIAGRAM-4 (CD)

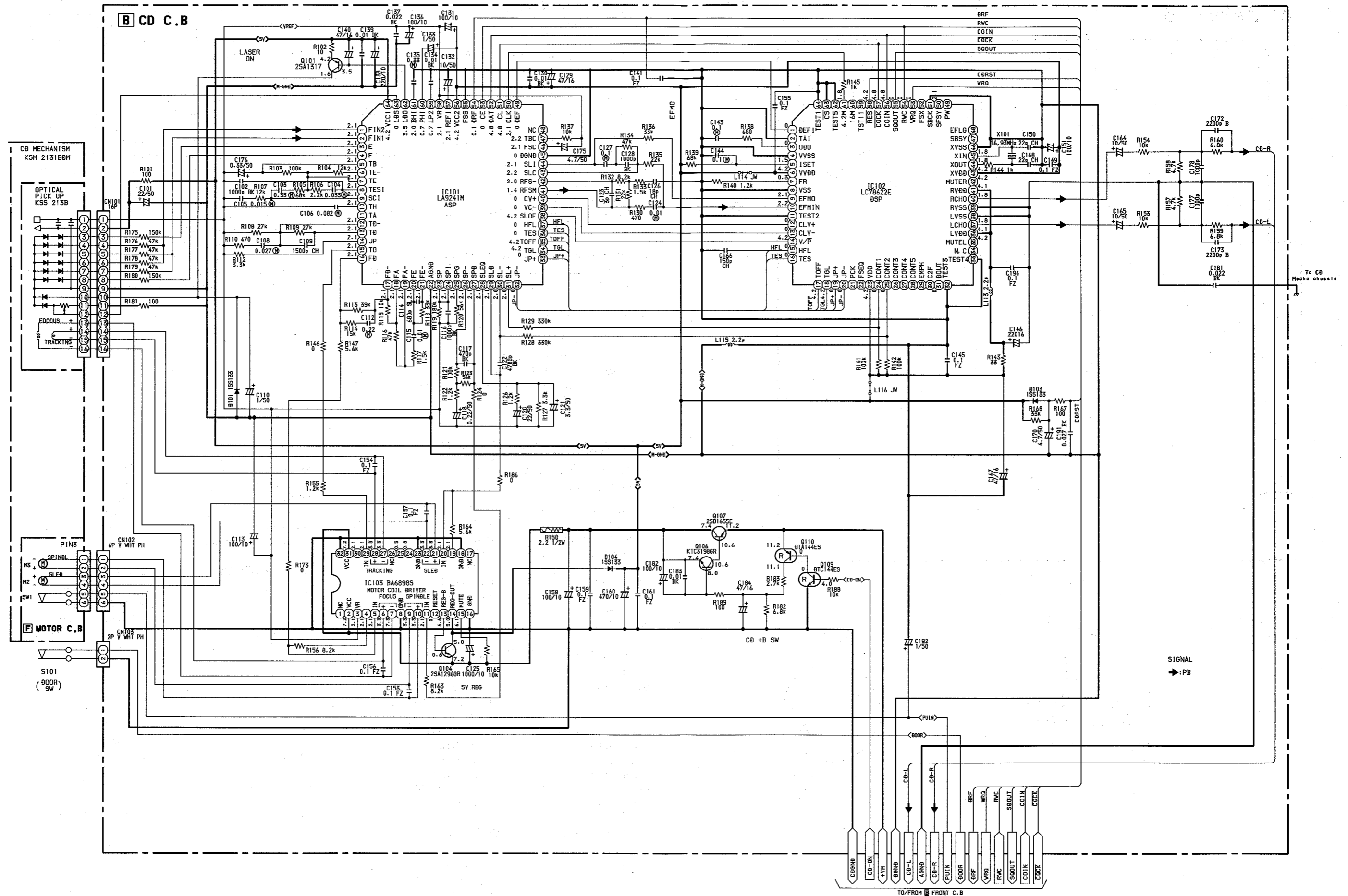

ELECTRICAL ADJUSTMENT

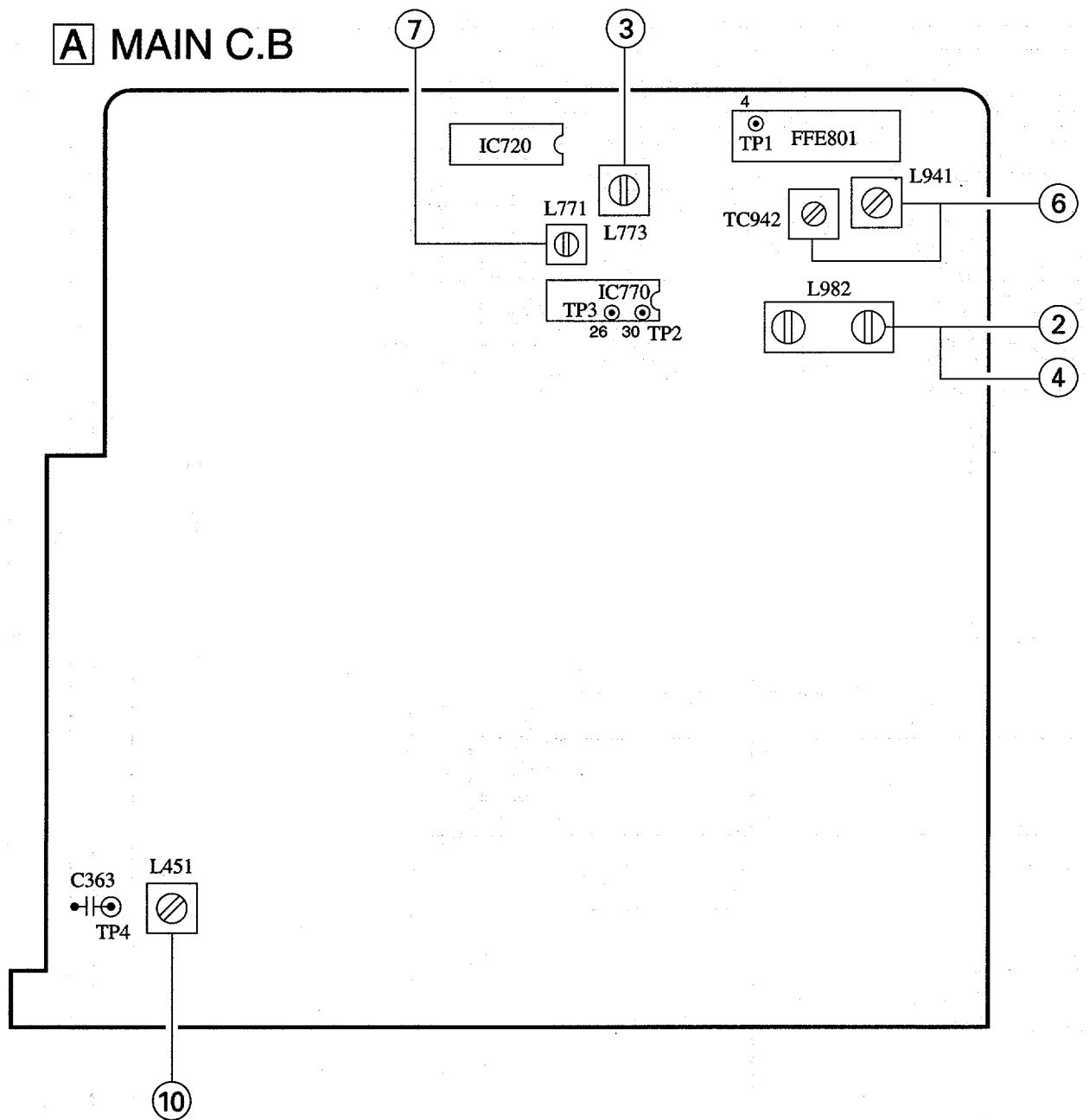

RPEH

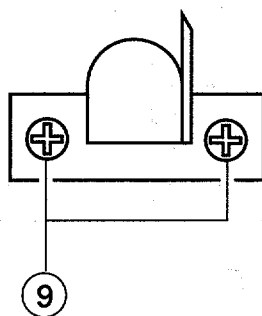

M1

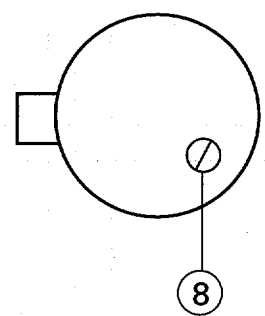

< TUNER SECTION >

1. AM VT Check (LH MODEL)
Settings: • Test point: TP1
Method: Set to AM 530kHz check that the test point becomes $1.3 \pm 0.1V$.
2. MW Tracking Adjustment (K, EZ MODELS)
L982 603kHz
3. AM (MW) IF Adjustment
L773 450kHz
4. AM Tracking Adjustment (LH MODEL)
L982 600kHz
5. FM VT Check
Settings: • Test point: TP1
Method: Set to FM 87.5MHz check that the test point is $4.0 \pm 0.1V$.
6. LW Tracking Adjustment (K, EZ MODELS)
L941 144kHz
TC942 290kHz
7. DC Balance/MONO Distortion Adjustment
Settings: • Test point: TP2, TP3
• Adjustment location: L771
• Input level: 60dB
Method: Set to FM 98.0MHz and adjust L771 so that the voltage between TP2 and TP3 becomes $0V \pm 20mV$.

< TAPE SECTION >

8. Tape speed Adjustment
Settings: • Test tape: TTA-100
• Adjustment location: SFR of deck motor.
Method: Play back the test tape with DECK1 and adjust SFR of deck motor so that the output frequency is 3000Hz.
9. Azimuth Adjustment
Settings: • Test tape: TTA-320
• Adjustment location: Head azimuth adjustment screw
Method: Play back the 8kHz signal of the test tape and adjust screw so that the output becomes maximum. Next, perform on each FWD PLAY and REV PLAY mode.
10. AC Bias Adjustment
Settings: • Test tape: TTA-602
• Test point: TP4
• Adjustment location: L451
Method: Set up the recording mode. Adjust L451 so that the TP4 becomes $56 \pm 1kHz$.

PRACTICAL SERVICE FIGURE

< TUNER SECTION >

< FM SECTION >

IHF Sensitivity: (THD 3%)	15dB \pm 5dB (at 90MHz) 14dB \pm 5dB (at 98.0/108.0MHz)
Signal to noise ratio: (Input 54dB)	More than 50dB (at 98.0MHz)
Distortion: (Input 54dB)	Less than 2.0% (at 98.0MHz)
Auto stop level:	25 \pm 10dB (at 98.0MHz)
Stereo separation:	More than 25dB (at 98.0MHz)
Intermediate frequency:	10.7MHz

< AM SECTION > (LH MODEL)

Sensitivity: (S/N 10dB)	46dB \pm 5dB (at 600kHz) 44dB \pm 5dB (at 999kHz) 42dB \pm 5dB (at 1404kHz)
Signal to noise ratio: (Input 74dB)	More than 38dB (at 1000kHz)
Distortion: (Input 74dB)	Less than 4.0% (at 1000kHz)
Auto stop level:	35-60dB (at 1000kHz)
Intermediate frequency:	450kHz

< MW SECTION > (K, EZ MODELS)

Sensitivity: (S/N 10dB)	46dB \pm 5dB (at 603kHz) 44dB \pm 5dB (at 999kHz) 42dB \pm 5dB (at 1404kHz)
----------------------------	---

Signal to noise ratio: (Input 74dB)	More than 38dB (at 999kHz)
Distortion: (Input 74dB)	Less than 2.0% (at 999kHz)
Auto stop level:	35-60dB (at 999kHz)
Intermediate frequency:	450kHz

< LW SECTION > (K, EZ MODELS)

Sensitivity:	58 \pm 5dB (at 160kHz) 55 \pm 5dB (at 200kHz) 52 \pm 5dB (at 280kHz)
Signal to noise ratio:	More than 25dB (at 198kHz)
Intermediate frequency:	450kHz

< DECK SECTION >

Tape speed:	3000Hz+3%/-2%
Wow & flutter:	Less than 0.35% (JIS, R.M.S)
Distortion:	Less than 3.0% (PB) Less than 7.0% (REC)
Signal to noise ratio:	More than 40dB (PB) More than 35dB (REC/PB)
Erasing ratio:	More than 55dB
Cross talk:	More than 50dB
Separation:	More than 35dB

IC DESCRIPTION

IC, LC867248A

Pin No.	Pin Name	I/O	Description
1	O-SCONTM	O	M62439SP control.
2	O-SCONTL	O	
3	O-TUDI	O	Tuner control.
4	I-TUDO	I	Tuner control.
5	O-TUCL	O	Tuner control.
6	O-COIN	O	CD control.
7	I-SQOUT	I	CD control.
8	O-CQCK	O	CD control.
9	O-RWC	O	
10	O-CLKSFT	O	Clock shift output. "L" during shift.
11	I-TMBASE	I	8 Hz time base input.
12	I-RESET	I	Reset input.
13, 14	XT1, XT2	I/O	Sub clock input/output 32.768kHz.
15	VSS1	—	GND.
16, 17	CF1, CF2	I/O	Main clock input/output 5.76 MHz.
18	VDD1	—	+5V.
19	I-KEY0	I	KEY0 A/D input.
20	I-KEY1	I	KEY1 A/D input.
21	I-RDSIG	I	RDS signal level input. (A/D input)
22	I-WRQ	I	CD control.
23	I-DRF	I	
24	I-DOOR	I	CD door SW detection SW input. "L" at CLOSE.
25	I-PUIN	I	CD pick-up detection SW input. "L" at ON.
26	I-SWTAPE	I	Tape detection SW input. (A/D input)
27	I-STEREO	I	Monaural/stereo indication selector input. "L" at stereo.
28	I-RDCL	I	RDS clock input.
29	I-REM	I	Remote control input. (fall-down edge interrupt input)
30	I-HOLD	I	Hold mode detection. "L" at hold mode.
31	I-RDDT	I	RDS data input.
32	I-TPREC	I	Tape REC detection input. "H" at REC.
33	I-TPPLAY	I	Tape PLAY detection input. "H" at PLAY.
34	O-MOTOR	O	Mechanism deck motor ON/OFF output. "H" at ON.
35	O-PL	O	Mechanism deck plunger solenoid ON/OFF output. "H" at ON.
36-38	NC	O	Not used.
39-55	S9-S25	O	LCD SEG terminal Initial setting output. (S10 to S16)
56	VDD2	—	+5V.
57	VSS2	—	GND.
58-79	S26-S47	O	LCD SEG terminal .
80	I-CLKDSP	I	Watch indication select input "L": 12H. "H": 24H.
81	I-AS	I	Auto stop. counter input .
82	I-STOP	I	Tape stop input.

Pin No.	Pin Name	I/O	Description
83-86	COM0-COM3	O	LCD common output.
87	I-INIT	I	Initial setting input.
88	I-AC/DC	I	AC/DC detection input. "L" at DC.
89	VSS3	—	GND.
90	VDD3	—	5V.
91	O-QSDON	O	Q sound ON/OFF output. "H" at ON.
92	O-TUCE	O	Tuner chip enable output.
93	O-CD-ON	O	"H" output during CD function.
94	O-TU-ON	O	"H" output during TU function.
95	O-RMT	O	REC mute output. "H" during mute.
96	O-REC/PB	O	REC/PB select output. "H" during PB.
97	O-MUTE	O	Mute output. "H" during mute.
98	O-PCONT	O	Power control output. "H" at ON.
99	O-BIAS	O	REC bias ON/OFF output. "H" at ON.
100	NC	O	Not used.

IC, LA9241ML

Pin No.	Pin Name	I/O	Description
1	FIN2	I	Pin to which external pickup photo diode is connected. RF signal is created by adding with the FIN1 pin signal. FE signal is created by subtracting from the FIN1 pin signal.
2	FIN1	I	Pin to which external pickup photo diode is connected.
3	E	I	Pin to which external pickup photo diode is connected. TE signal is created by subtracting from the F pin signal.
4	F	I	Pin to which external pickup photo diode is connected.
5	TB	I	DC component of the TE signal is input.
6	TE-	I	Pin to which external resistor setting the TE signal gain is connected between the TE pin.
7	TE	O	TE signal output pin.
8	TESI	I	TES "Track Error Sense" comparator input pin. TE signal is passed through a band-pass filter then input.
9	SCI	I	Shock detection signal input pin.
10	TH	I	Tracking gain time constant setting pin.
11	TA	O	TA amplifier output pin.
12	TD-	I	Pin to which external tracking phase compensation constants are connected between the TD and VR pins.
13	TD	I	Tracking phase compensation setting pin.
14	JP	I	Tracking jump signal (kick pulse) amplitude setting pin.
15	TO	O	Tracking control signal output pin.
16	FD	O	Focusing control signal output pin.
17	FD-	I	Pin to which external focusing phase compensation constants are connected between the FD and FA pins.
18	FA	I	Pin to which external focusing phase compensation constants are connected between the FD- and FA- pins.
19	FA-	I	Pin to which external focusing phase compensation constants are connected between the FA and FE pins.
20	FE	O	FE signal output pin.
21	FE-	I	Pin to which external FE signal gain setting resistor is connected between the FE pin.
22	AGND	—	Analog signal GND.
23	NC	—	No connection.
24	SP	O	Single ended output of the CV+ and CV- pin input signal.
25	SPG	I	Pin to which external spindle gain setting resistor in 12 cm mode is connected.
26	SP-	I	Pin to which external spindle phase compensation constants are connected together with SPD pin.
27	SPD	O	Spindle control signal output pin.
28	SLEQ	I	Pin to which external sled phase compensation constants are connected.
29	SLD	O	Sled control signal output pin.
30, 31	SL-, SL+	I	Sled advance signal input pin from microprocessor.
32, 33	JP-, JP+	I	Tracking jump signal input pin from DSP.
34	TGL	I	Tracking gain control signal input from DSP. Low gain when TGL = H.
35	TOFF	I	Tracking off control signal input pin from DSP. Off when TOFF = H.

Pin No.	Pin Name	I/O	Description
36	TES	O	Pin from which TES signal is output to DSP.
37	HFL	O	“High Frequency Level” is used to judge whether the main beam position is on top of bit or on top of mirror.
38	SLOF	I	Sled servo off control input pin.
39, 40	CV-, CV+	I	CLV error signal input pin from DSP.
41	RFSM	O	RF output pin.
42	RFS-	I	RF gain setting and EFM signal 3T compensation constant setting pin together with RFSM pin.
43	SLC	O	“Slice Level Control” is the output pin which controls the RF signal data slice level by DSP.
44	SLI	I	Input pin which control the data slice level by the DSP.
45	DGND	—	Digital system GND.
46	FSC	O	Output pin to which external focus search smoothing capacitor is connected.
47	TBC	I	“Tracking Balance Control” EF balance variable range setting pin.
48	NC	—	No connection.
49	DEF	O	Disc defect detector output pin.
50	CLK	I	Reference clock input pin. 4.23 MHz of the DSP is input.
51	CL	I	Microprocessor command clock input pin.
52	DAT	I	Microprocessor command data input pin.
53	CE	I	Microprocessor command chip enable input pin.
54	DRF	O	“Detect RF” RF level detector output.
55	FSS	I	“Focus Search Select” focus search mode (\pm search/+ search) select pin.
56	VCC2	—	Servo system and digital system Vcc pin.
57	REFI	—	Pin to which external bypass capacitor for reference voltage is connected.
58	VR	O	Reference voltage output pin.
59	LF2	I	Disc defect detector time constant setting pin.
60	PH1	I	Pin to which external capacitor for RF signal peak holding is connected.
61	BH1	I	Pin to which external capacitor for RF signal bottom holding is connected.
62	LDD	O	APC circuit output pin.
63	LDS	I	APC circuit input pin.
64	VCC1	—	RF system Vcc pin.

IC, LC78622E

Pin No.	Pin Name	I/O	Description	
1	DEFI	I	Defect sense signal (DEF) input pin. (Connect to 0V when not used).	
2	TAI	I	For PLL.	Test signal input pin with built-in pull-down resistor. Be sure to connect to 0V.
3	PDO	O		Phase comparator output pin to control external VCO.
4	VVSS	—		GND pin for built-in VCO. Be sure to connect to 0V.
5	ISET	I		Pin to which external resistor adjusting the PDO output current.
6	VVDD	—		Power supply pin for built-in VCO.
7	FR	I		Pin for VCO frequency range adjustment.
8	VSS	—		Digital system GND. Be sure to connect to 0V.
9	EFMO	O	For slice level control.	EFM signal output pin.
10	EFMIN	I		EFM signal input pin.
11	TEST2	I	Test signal input pin with built-in pull-down resistor. Be sure to connect to 0V.	
12, 13	CLV+, CLV-	O	Disc motor control output. Three level output is possible using command.	
14	V/P	O	Rough servo or phase control automatic selection monitoring output pin. Rough servo at H. Phase servo at L.	
15	HFL	I	Track detect signal input pin. Schmidt input.	
16	TES	I	Tracking error signal input pin. Schmidt input.	
17	TOFF	O	Tracking OFF output pin.	
18	TGL	O	Tracking gain selection output pin. Gain boost at L.	
19, 20	JP+, JP-	O	Track jump control signal output pin. Three level output is possible using command.	
21	PCK	O	EFM data playback clock monitoring pin 4.3218 MHz when phase is locked in.	
22	FSEQ	O	Sync signal detection output pin. H when the sync signal which is detected from EFM signal and the sync signal which is internally generated agree.	
23	VDD	—	Digital system power supply pin.	
24-28	SL+ - PUIN	I/O	General purpose input/output pin 1 to 5.	The pin is controlled by the serial data command from microprocessor. When the pin is not used, set the pin to the input terminal and connect to 0V, or alternately set the pin to output terminal and leave the pin open.
29	EMPH	O	De-emphasis monitor output pin. De-emphasis disc is being played back at H.	
30	C2F	O	C2 flag output pin.	
31	DOUT	O	DIGITAL OUT output pin. (EIAJ format).	
32, 33	TEST3, TEST4	I	Test signal input pin with built-in pull-down resistor. Be sure to connect to 0V.	
34	N.C.	—	Not used. Set the pin to open.	
35	MUTEL	O	L-channel 1-bit DAC.	L-channel mute output pin.
36	LVDD	—		L-channel power supply pin.
37	LCHO	O		L-channel output pin.
38	LVSS	—		L-channel GND. Be sure to connect to 0V.
39	RVSS	—	R-channel 1-bit DAC.	R-channel GND. Be sure to connect to 0V.
40	RCHO	O		R-channel output pin.
41	RVDD	—		R-channel power supply pin.
42	MUTER	O		R-channel mute output pin.

Pin No.	Pin Name	I/O	Description
43	XVDD	—	Crystal oscillator power supply pin.
44	XOUT	O	Pin to which external 16.9344 MHz crystal oscillator is connected.
45	XIN	I	
46	XVSS	—	Crystal oscillator GND pin. Be sure to connect to 0V.
47	SBSY	O	Subcode block sync signal output pin.
48	EFLG	O	C1, C2, single and dual correction monitoring pin.
49	PW	O	Subcode P, Q, R, S, T, U and W output pin.
50	SFSY	O	Subcode frame sync signal output pin. Falls down when subcode enters standby.
51	SBCK	I	Subcode read clock input pin. Schmidt input. (Be sure to connected to 0V when not in use.)
52	FSX	O	Pin outputting the 7.35 kHz sync signal which is generated by dividing frequency of crystal oscillator.
53	WRQ	O	Subcode Q output standby output pin.
54	RWC	I	Read/write control input pin. Schmidt input.
55	SQOUT	O	Subcode Q output pin.
56	COIN	I	Command input pin from microprocessor.
57	$\overline{\text{CQCK}}$	I	Command input read clock or subcode read input clock from SQOUT pin
58	RES	I	LC78622 reset input pin. Set this pin to L once when the main power is turned on.
59	TST11	O	Test signal output pin. Use this pin as open (normally L output).
60	16M	O	16.9344 MHz output pin.
61	4.2M	O	4.2336 MHz output pin.
62	TEST5	I	Test signal input pin with built-in pull-down resistor. Be sure to connect to 0V.
63	$\overline{\text{CS}}$	I	Chip select signal input pin with built-in pull-down resistor. Be sure to connect to 0V while it is not controlling.
64	TEST1	I	Test signal input pin without built-in pull-down resistor. Be sure to connect to 0V.

Note: The same potential must be applied to the respective power supply terminals. (VDD, VVDD, LVDD, RVDD, XVDD)

LCD DISPLAY

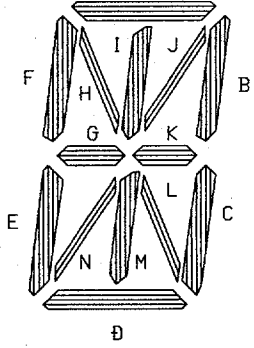
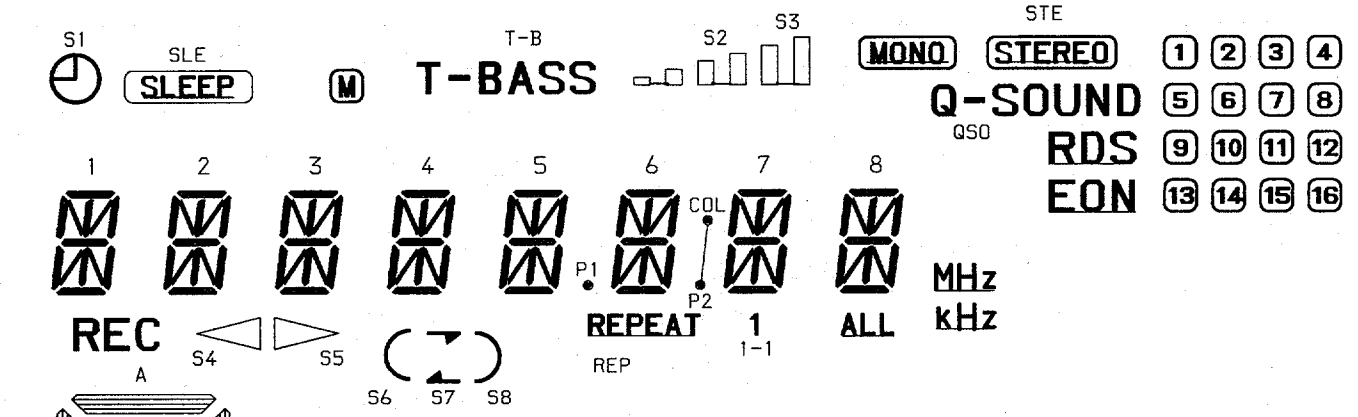

NO	COM1	COM2	COM3	COM4
1	COM1	---	---	---
2	---	COM2	---	---
3	---	---	COM3	---
4	---	---	---	COM4
5	16	12	8	4
6	15	11	7	3
7	14	10	6	2
8	13	9	5	1
9	EON	RDS	QSO	STE
10	ALL	KHz	MHz	1-1
11	8L	8C	8B	MONO
12	8M	8K	8J	8A
13	8N	8G	8H	8I
14	8D	8E	8F	REP
15	7L	7C	7B	---
16	7M	7K	7J	7A
17	7N	7G	7H	7I
18	7D	7E	7F	P2
19	6L	6C	6B	COL
20	6M	6K	6J	6A
21	6N	6G	6H	6I
22	6D	6E	6F	---
23	P1	S3	S2	T.B
24	5L	5C	5B	S8
25	5M	5K	5J	5A
26	5N	5G	5H	5I
27	5D	5E	5F	S7
28	4L	4C	4B	---
29	4M	4K	4J	4A
30	4N	4G	4H	4I
31	4D	4E	4F	S6
32	3L	3C	3B	M
33	3M	3K	3J	3A
34	3N	3G	3H	3I
35	3D	3E	3F	S5
36	2L	2C	2B	SLE
37	2M	2K	2J	2A
38	2N	2G	2H	2I
39	2D	2E	2F	S4
40	1L	1C	1B	S1
41	1M	1K	1J	1A
42	1N	1G	1H	1I
43	1D	1E	1F	REC

MECHANICAL PARTS LIST 1/1

DESCRIPTIONで判断できない物は "REFERENCE NAME LIST" を参照してください。
 If can't understand for Description please kindly refer to "REFERENCE NAME LIST".

REF. NO	PART NO.	KANRI NO.	DESCRIPTION	REF. NO	PART NO.	KANRI NO.	DESCRIPTION
1	88-CL5-018-010		CABI, FRONT EZ<352EZ>	28	88-CL5-003-010		LID, CD<EXCEPT 358EZ>
1	88-CLF-001-010		CABI, FRONT F<358EZ>	28	88-CLF-004-010		LID, CD F<358EZ>
1	88-CL5-017-010		CABI, FRONT U<350LH, 350K>	29	88-CL5-004-010		WINDOW, CD
2	86-CL9-017-010		FOOT, RBR	30	88-CL5-002-010		CABI, REAR<350LH>
3	82-NF5-219-010		SPR-T, EJECT 2 (SIN)	30	88-CL5-023-010		CABI, REAR EZ<352EZ, 358EZ>
4	88-CL5-011-010		WINDOW, CASS BOX	30	88-CL5-024-010		CABI, REAR K<350K>
5	88-CL5-010-010		BOX, CASS	31	88-CL5-015-010		FOOT,
6	88-CL5-009-010		RING, KEY	32	88-CL5-637-010		PT, EZ<EXCEPT 350LH>
7	88-CL5-021-010		KEY, STOP	32	88-CL5-635-010		PT, H<350LH>
8	88-CL5-020-010		KEY, DIR	33	88-CL5-636-010		AC CORD ASSY, H<EXCEPT 350K>
9	88-CL5-006-010		WINDOW, FRONT RANE L	33	88-CL5-638-010		AC CORD ASSY, K<350K>
10	81-CD1-032-010		BADGE, AIWA 30J	34	S8-024-310-000		SW, SLIDE 1P1T
11	88-CL5-007-010		KEY, POWER/FUN	35	87-CD4-227-010		PANEL, PLATE B
12	88-CL5-008-010		KEY, EQ<350LH, 350K>	36	82-ZM1-264-010		LVR, EJECT R
12	88-CL5-043-010		KEY, RDS<352EZ, 358EZ>	A	87-251-033-410		BH/MS 2X4
13	88-CL5-019-010		KEY, CONTROL	B	87-481-097-410		WPH/TSM 3X12
14	88-CL5-202-010		HLDR, CASS LOCKE R	C	87-741-094-410		BH/TS 3X6
15	88-CL5-203-010		LEVER, CASS LOCKE R	D	87-741-095-410		BH/TS 3X8
16	84-CD5-216-010		BRACKET	E	87-743-096-410		BH/TS 3X10
17	84-CD5-215-010		GEAR	F	87-B10-159-010		BH/TS 3X18
18	87-CD4-045-010		COVER, CD MECHA	G	87-078-150-010		RH/MS 3X6
19	82-NF5-228-010		SPR-C, LOCK	H	81-CD5-204-010		CD SCREW 2X17
20	87-CD7-206-010		DOOR, CD LOCKER	I	87-721-096-410		KH/TS 3X10
21	82-NF5-229-010		PLATE, LOCK	J	87-351-549-310		PH/MS 2X4
22	87-CD7-210-010		GEAR, CD DOOR	K	87-351-551-310		PH/TS 2X5
23	88-CL5-022-010		CHAS, CD BRACKET	L	87-354-553-310		PH/TS 2X6
24	88-CL5-208-010		SPR-T, CD LID	M	87-761-094-410		WPH/TSM 3X6
25	87-CD4-238-010		BASE, CHUCK				
26	87-036-368-010		MAGNET				
27	87-CD4-219-010		PLATE, MAGNET				

TAPE MECHANISM EXPLODED VIEW 1/1

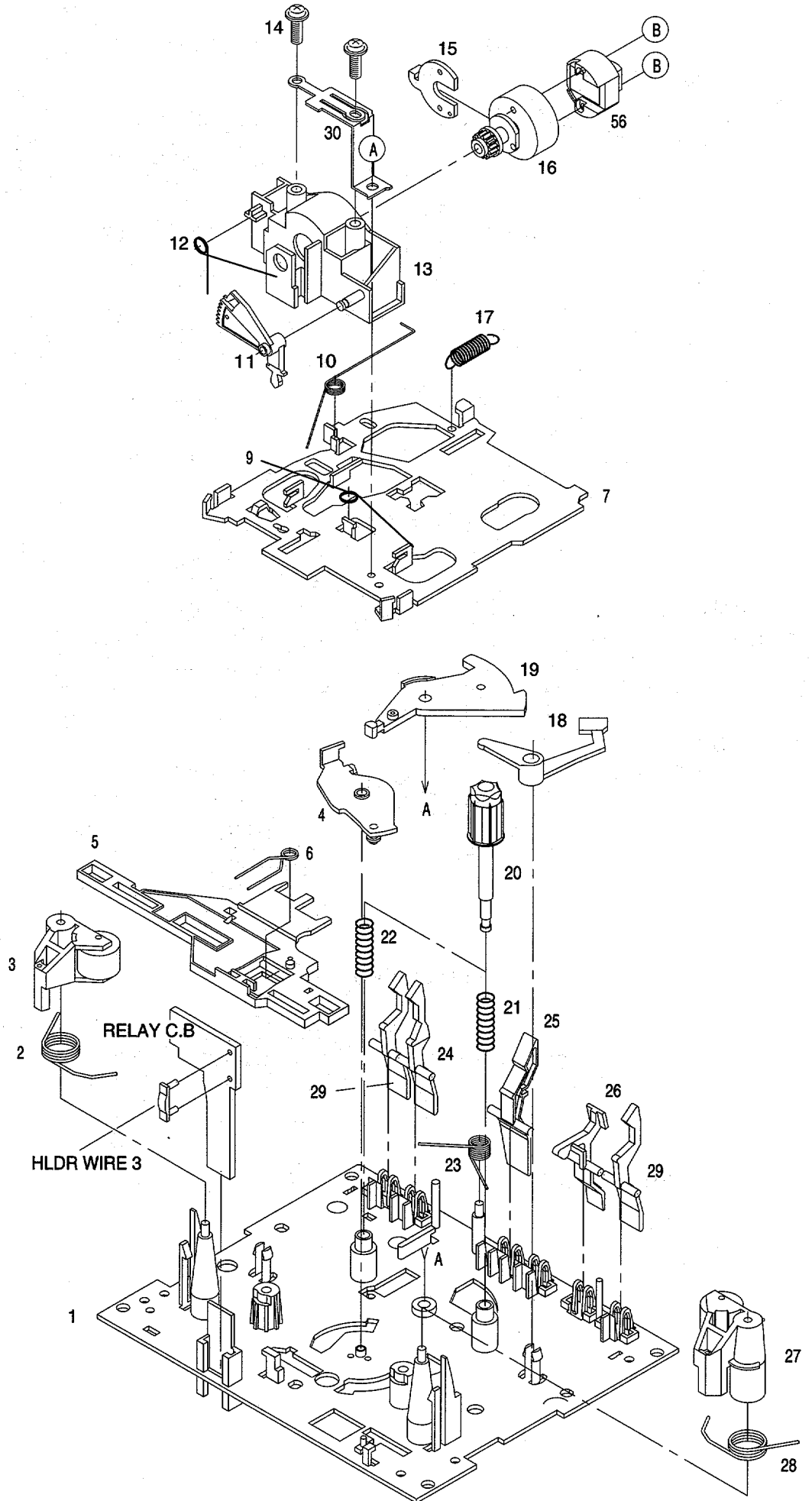

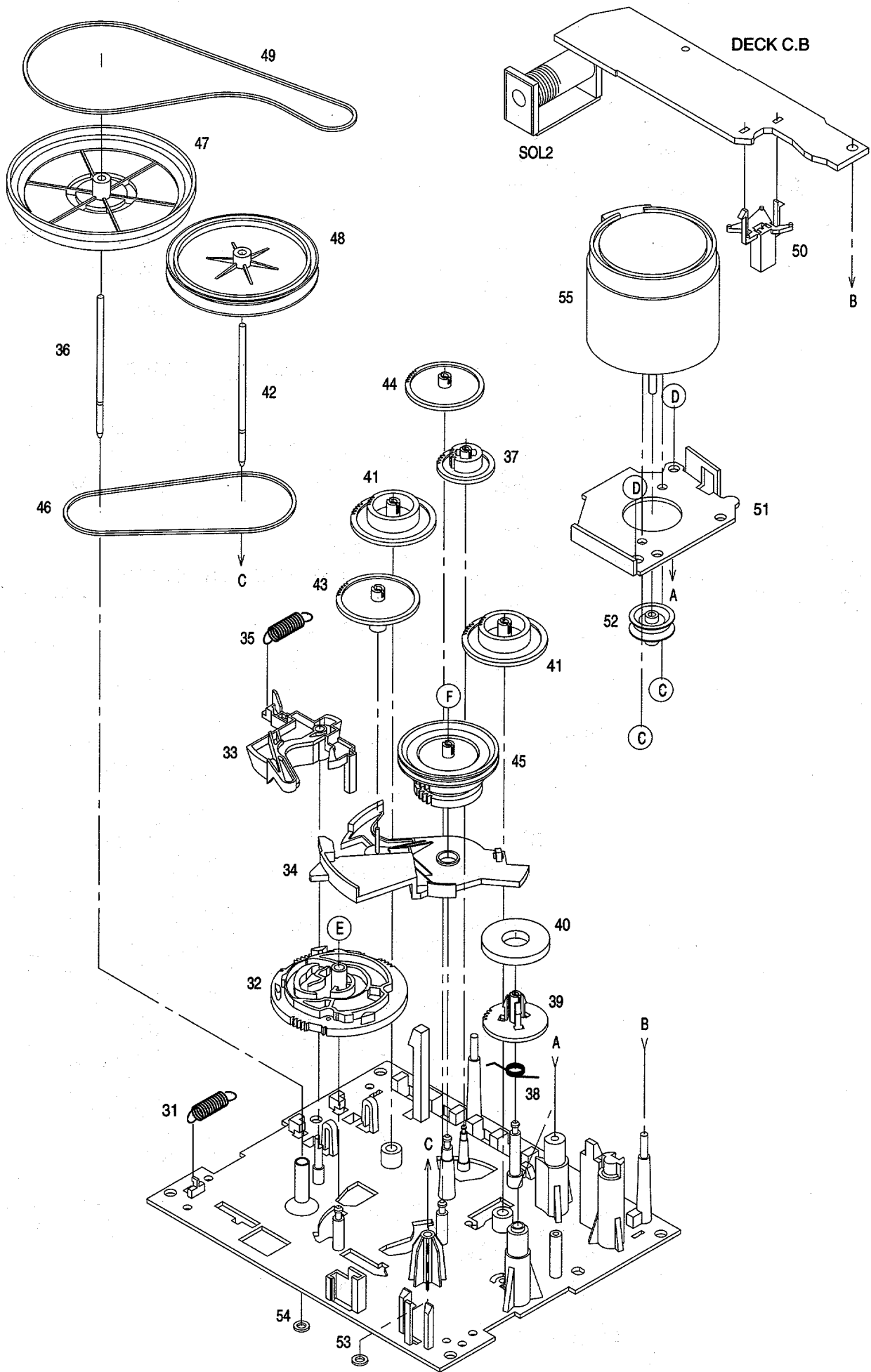

TAPE MECHANISM PARTS LIST 1/1

DESCRIPTIONで判断できない物は "REFERENCE NAME LIST" を参照してください。
 If can't understand for Description please kindly refer to "REFERENCE NAME LIST".

REF. NO	PART NO.	KANRI NO.	DESCRIPTION	REF. NO	PART NO.	KANRI NO.	DESCRIPTION
1	82-ZM1-327-210		CHAS ASSY, RN	37	82-ZM1-223-010		GEAR, PLAY
2	82-ZM1-258-010		SPR-T, PINCH L	38	82-ZM1-322-010		SPR-T, FR 60
3	82-ZM1-341-010		LVR ASSY, PINCH L 2	39	82-ZM1-220-210		GEAR, IDLER
4	82-ZM1-295-310		PLATE ASSY, LINK	40	82-ZM1-316-010		RING MAGNET 3
5	82-ZM1-266-110		LVR, DIR	41	82-ZM1-216-310		GEAR, REEL
6	82-ZM1-214-010		SPR-T, DIR	42	82-ZM1-236-010		CAPSTAN, 2-41.5
7	82-ZM1-206-810		CHAS, HEAD	43	82-ZM1-225-010		GEAR, FR
9	82-ZM1-269-210		SPR-T, BRG	44	82-ZM1-226-010		GEAR, REW
10	82-ZM3-323-010		SPR-T, LINK 3	45	82-ZM3-333-210		SLIP DISK ASSY 2
11	82-ZM1-210-110		GEAR, H T	46	82-ZM1-338-010		BELT, FR 4
12	82-ZM1-213-010		SPR-T, HEAD	47	82-ZM1-349-010		FLY-WHL, RH
13	82-ZM1-207-610		GUIDE, TAPE	48	82-ZM1-348-010		FLY-WHL, LW
14	82-ZM1-283-310		S-SCREW, AZIMUTH	49	82-ZM1-340-010		BEKT, SBU MAIN 2
15	82-ZM1-314-119		PLATE, HEAD	50	82-ZM1-245-210		HLDL, IC
16	82-ZM1-208-110		HLDL, HEAD	51	82-ZM1-246-010		HLDL, MOTOR
17	82-ZM1-218-010		SPR-E, HB	52	82-ZM1-247-110		PULLEY, MOTOR
18	82-ZM1-264-010		LVR, EJECT R	53	82-ZM1-288-010		SH, 1.63-3.2-0.5 SLT
19	82-ZM1-222-210		LVR, PLAY	54	80-ZM6-243-010		SH, 1.75-3.6-0.5 SLT
20	82-ZM1-217-310		REEL TABLE	55	87-045-347-010		MOT, SHU 2L 70(M1)
21	82-ZM1-244-510		SPR-C, BT	56	87-046-399-010		HEAD, RPH YK56R-BS409(RPH)
22	82-ZM1-285-410		SPR-C, BT L	A	82-ZM1-315-010		S-SCREW, GUIDE TAPE
23	82-ZM1-257-010		SPR-T, CAS	B	80-ZM6-207-010		V+1.6-7
24	82-ZM1-241-310		LVR, MC	C	87-251-070-410		U+2.6-3
25	82-ZM1-242-010		LVR, CAS	D	87-741-073-410		UT2+2.6-6 GLD
26	82-ZM1-243-010		LVR, STOP	E	87-B10-008-010		PW, 2.15-6.8-0.4 SLT
27	82-ZM1-344-010		LVR ASSY, PINCH R	F	82-ZM3-334-010		PW, 2.16-6-0.4
28	82-ZM1-259-110		SPR-T, PINCH R				
29	82-ZM1-240-110		LVR, REC				
30	82-ZM1-298-010		SPR-P, EARTH				
31	82-ZM1-255-310		SPR-E, LVR DIR				
32	82-ZM1-221-110		GEAR, CAM				
33	82-ZM1-227-210		LVR, TRIG				
34	82-ZM1-224-410		LVR, FR				
35	82-ZM1-305-110		SPR-E, TRIG 2				
36	82-ZM1-239-010		CAPSTAN 2.2-41.7				

CD MECHANISM EXPLODED VIEW 1/1

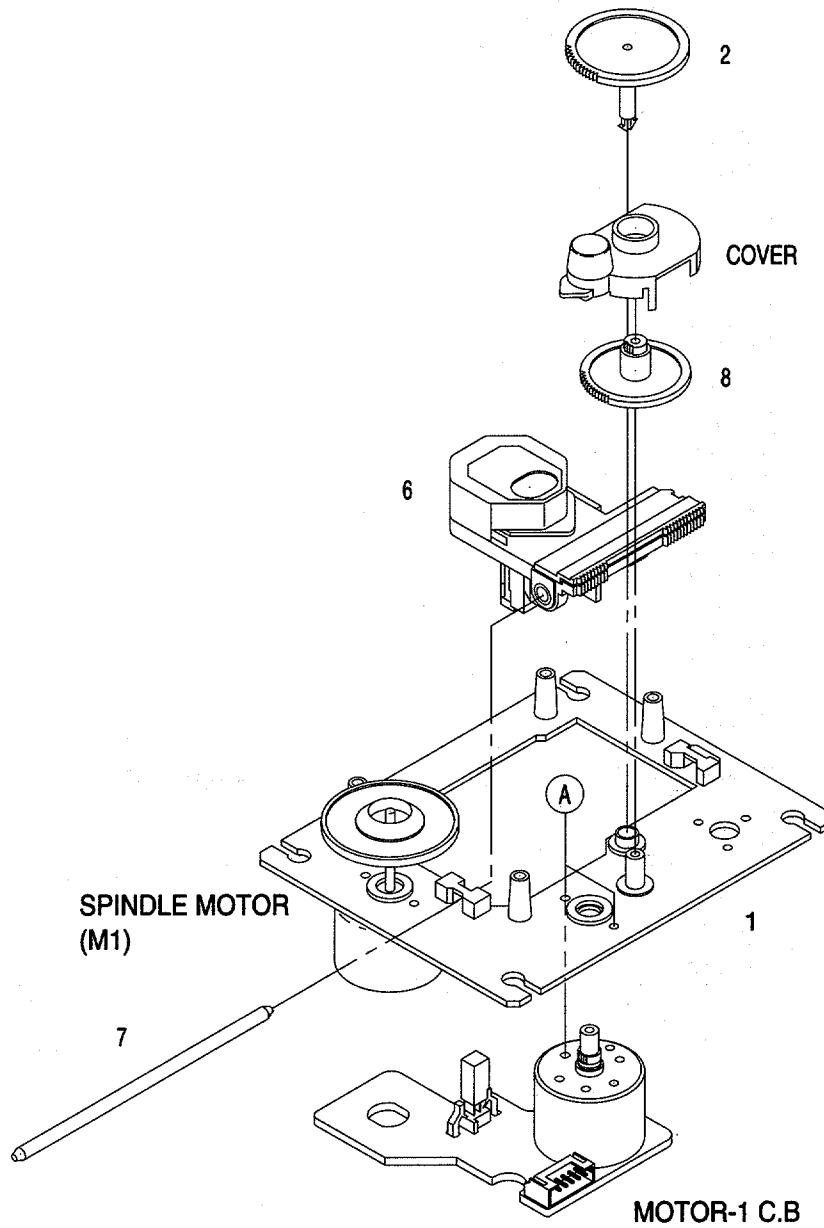

CD MECHANISM PARTS LIST 1/1

DESCRIPTIONで判断できない物は "REFERENCE NAME LIST" を参照してください。
 If can't understand for Description please kindly refer to "REFERENCE NAME LIST".

REF. NO	PART NO.	KANRI NO.	DESCRIPTION
1	9X-262-587-010		MOTOR CHASSIS ASSY
2	92-626-907-010		GEAR (A)
6	98-848-376-110		OPTICAL PICK UP KSS-213B RP
7	92-626-908-010		SHAFT SLED
8	92-627-003-010		GEAR B
A	97-621-255-150		SCREW+P2-3

Note: REF.NOs. 3, 4 and 5 are not used.

SPEAKER PARTS LIST 1/1 (LCX-350/352)

DESCRIPTIONで判断できない物は "REFERENCE NAME LIST" を参照してください。
If can't understand for Description please kindly refer to "REFERENCE NAME LIST".

REF. NO	PART NO.	KANRI NO.	DESCRIPTION
1	81-CD1-032-010		BADGE, AIWA 30J
2	88-CL5-012-010		CABI, FRONT SPKR<LH, K>
2	88-CL5-041-010		CABI, FRONT SPKR 2WAY<352EZ>
3	88-CL5-013-010		FRAME, SPKR<LH, K>
3	88-CL5-042-010		FRAME, SPKR 2WAY<352EZ>
4	88-CL5-204-010		FRAME, SPKR
5	88-CL5-764-010		CORD, SPEAKER<LH, K>
5	88-CL5-766-010		CORD, SPEAKER-2WAY<352EZ>
6	88-CL5-762-010		SPKR, CERTWEETER<352EZ>
6	88-CL5-761-010		SPKR, 10 8OHM<LH, K>
7	88-CL5-763-010		SPKR, DUSTCAP<352EZ>

SPEAKER EXPLODED VIEW 1/1 (LCX-358)

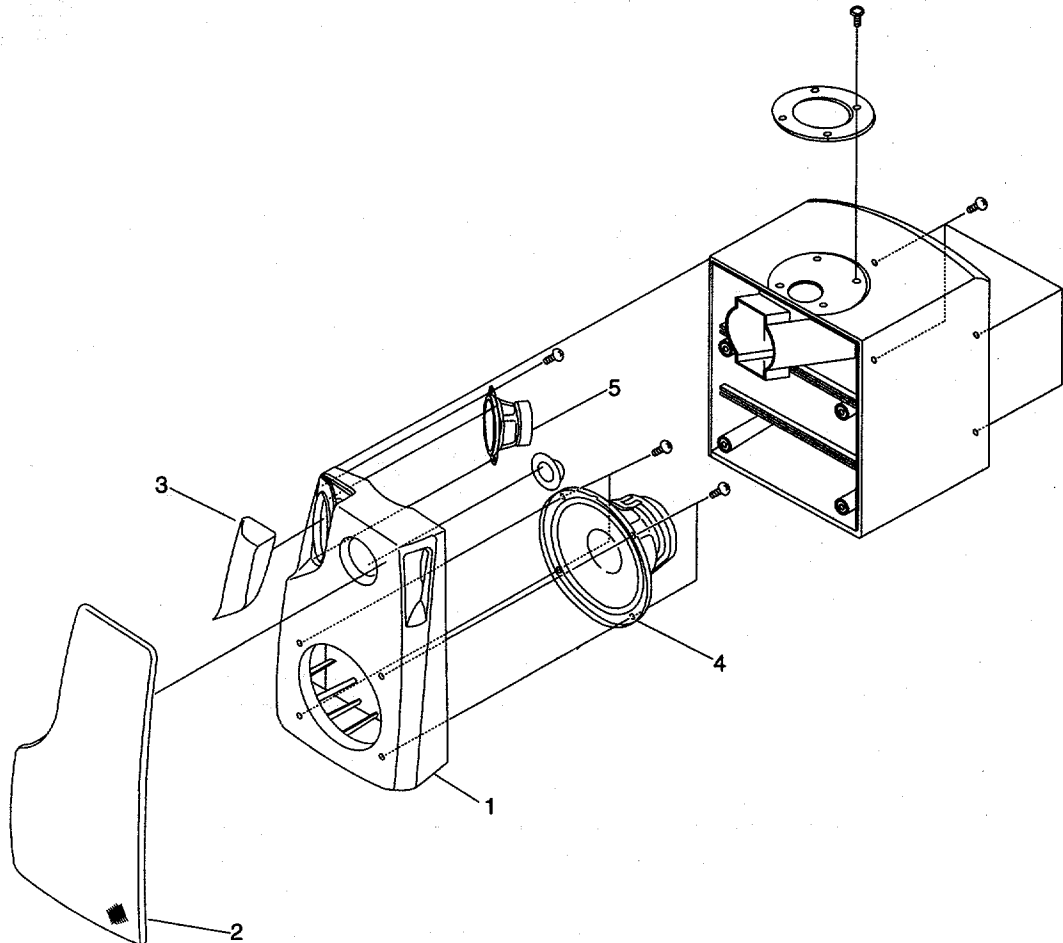

SPEAKER PARTS LIST 1/1 (LCX-358)

DESCRIPTIONで判断できない物は "REFERENCE NAME LIST" を参照してください。
If can't understand for Description please kindly refer to "REFERENCE NAME LIST".

REF. NO	PART NO.	KANRI NO.	DESCRIPTION
1	87-CLE-001-010		PANEL, FR R
1	87-CLE-002-010		PANEL, FR L
2	87-CLE-004-010		GRILLE FRAME R
2	87-CLE-005-010		GRILLE FRAME L
3	87-CLE-009-010		PROTECTOR, TW
4	87-CLE-771-010		SPKR, WOOFER
5	87-CLE-772-010		SPKR, MID-R

SPRING APPLICATION POSITION

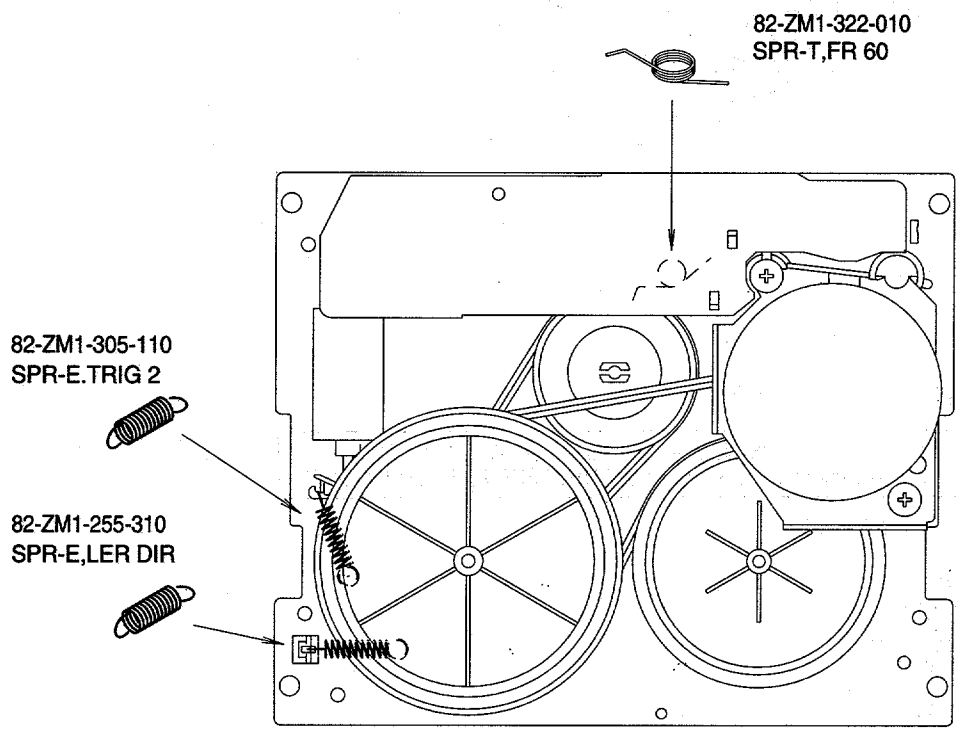
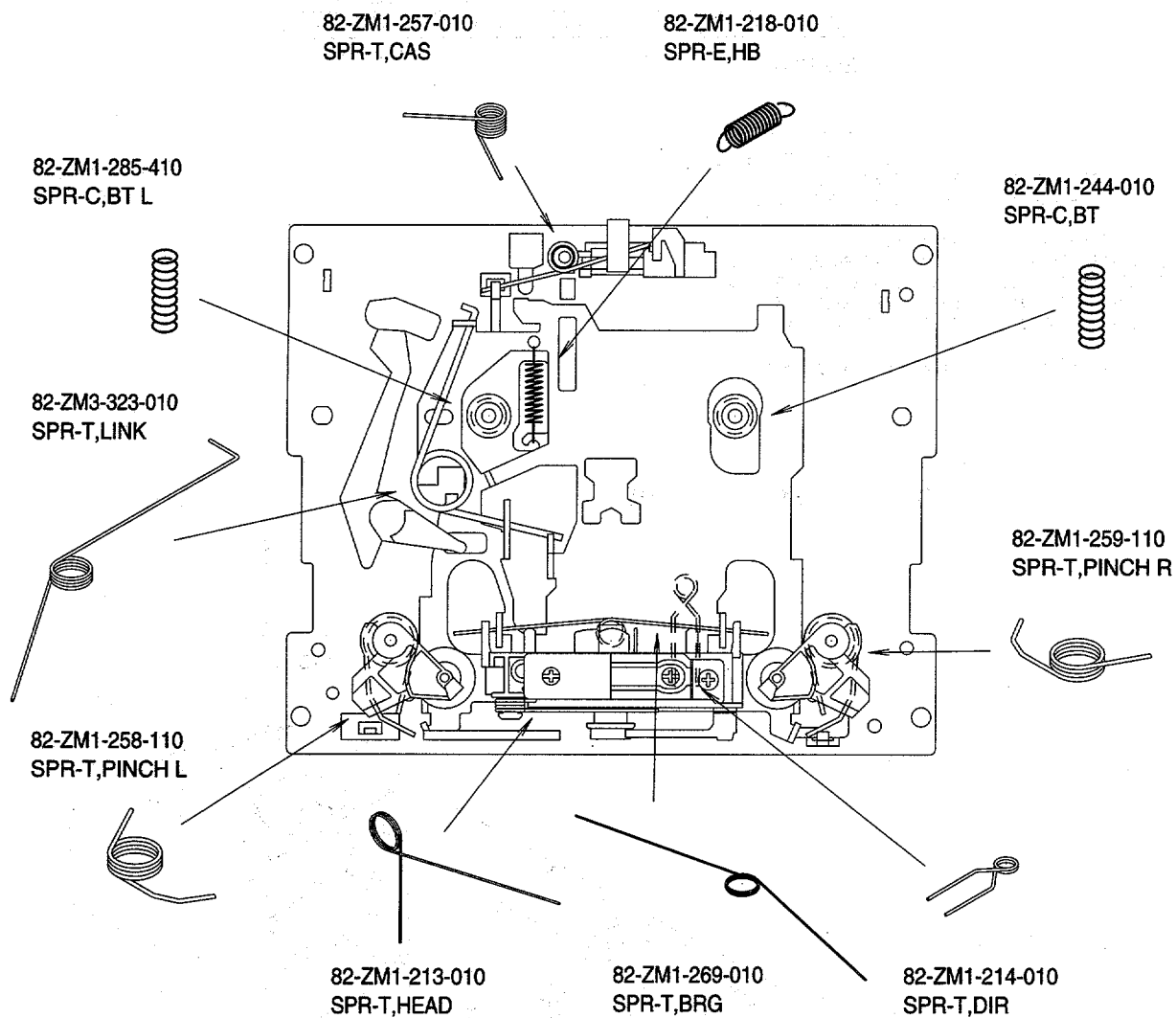

REFERENCE NAME LIST

ELECTRICAL SECTION

DESCRIPTION	REFERENCE NAME
ANT	ANTENNAS
C-	CHIP
C-CAP	CAP, CHIP
C-CAP TN	CAP, CHIP TANTALUM
C-COIL	COIL, CHIP
C-DI	DIODE, CHIP
C-DIODE	DIODE, CHIP
C-FET	FET, CHIP
C-FOTR	FILTER, CHIP
C-JACK	JACK, CHIP
C-LED	LED, CHIP
C-RES	RES, CHIP
C-SFR	SFR, CHIP
C-SLIDE SW	SLIDE SWITCH, CHIP
C-SW	SWITCH, CHIP
C-TR	TRANSISTOR, CHIP
C-VR	VOLUME, CHIP
C-ZENER	ZENER, CHIP
CAP, CER	CAP, CERA-SOL
CAP, E	CAP, ELECT
CAP, M/F	CAP, FILM
CAP, TC	CAP, CERA-SOL
CAP, TC-U	CAP, CERA-SOL SS
CAP, TN	CAP, TANTALUM
CERA FIL	FILTER, CERAMIC
CF	FILTER, CERAMIC
DL	DELAY LINE
E/CAP	CAP, ELECT
FILT	FILTER
FLTR	FILTER
FUSE RES	RES, FUSE
MOT	MOTOR
P-DIODE	PHOTO DIODE
P-SNSR	PHOTO SENSER
P-TR	PHOTO TRANSISTOR
POLY VARI	VARIABLE CAPACITOR
PPCAP	CAP, PP
PT	POWER TRANSFORMER
PTR, RES	PTR, MELF
RC	REMOTE CONTROLLER
RES NF	RES, NON-FLAMMABLE
RESO	RESONATOR
SHLD	SHIELD
SOL	SOLENOID
SPKR	SPEAKER
SW, LVR	SWITCH, LEVER
SW, RTRY	SWITCH, ROTARY
SW, SL	SWITCH, SLIDE
TC CAP	CAP, CERA-SOL
THMS	THERMISTOR
TR	TRANSISTOR
TRIMMER	CAP, TRIMMER
TUN-CAP	VARIABLE CAPACITOR
VIB, CER	RESONATOR, CERAMIC
VIB, XTAL	RESONATOR, CRYSTAL
VR	VOLUME
ZENER	DIODE, ZENER

MECHANICAL SECTION

DESCRIPTION	REFERENCE NAME
ADHESHIVE	SHEET ADHESHIVE
AZ	AZIMUTH
BAR-ANT	BAR-ANTENNA
BAT	BATTERY
BATT	BATTERY
BRG	BEARING
BTN	BUTTON
CAB	CABINET
CASS	CASSETTE
CHAS	CHASSIS
CLR	COLLAR
CONT	CONTROL
CRSR	CURSOR
CU	CUSHION
CUSH	CUSHION
DIR	DIRECTION
DUBB	DUBBING
FL	FRONT LOADING
FLY-WHL	FLYWHEEL
FR	FRONT
FUN	FUNCTION
G-CU	G-CUSHION
HDL	HANDOL
HIMERON	CLOTH
HINGE, BAT	HINGE, BATTERY
HLDR	HOLDER
HT-SINK	HEAT SINK
IB	INSTRUCTION BOOKLET
IDLE	IDLER
IND, L-R	INDICATOR, L-R
KEY, CONT	KEY, CONTROL
KEY, PRGM	KEY, PROGRAM
KNOB, SL	KNOB, SLIDE
LBL	LABEL
LID, BATT	LID, BATTERY
LID, CASS	LID, CASSETTE
LVR	LEVER
P-SP	P-SPRING
PANEL, CONT	PANEL, CONTROL
PANEL, FR	PANEL, FRONT
PRGM	PROGRAM
PULLY, LOAD MO	PULLY, LOAD MOTOR
RBN	RIBBON
S-	SPECIAL
SEG	SEGMENT
SH	SHEET
SHLD-SH	SHIELD-SHEET
SL	SLIDE
SP	SPRING
SP-SCREW	SPECIAL-SCREW
SPACER, BAT	SPACER, BATTERY
SPR	SPRING
SPR-P	P-SPRING
SPR-PC-PUSH	P-SPRING, C-PUSH
T-SP	T-SPRING
TERM	TERMINAL
TRIG	TRIGGER
TUN	TUNING
VOL	VOLUME
W	WASHER
WHL	WHEEL
WORM-WHL	WORM-WHEEL

サービス技術ニュース	
番号	連絡内容
G- -	
G- -	
G- -	

アイワ株式会社
AIWA CO.,LTD.

931261

Tokyo Japan