

aiwa

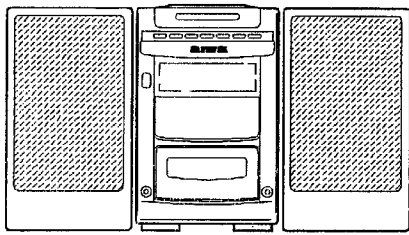

LCX-700M



COMPACT DISC STEREO SYSTEM

- BASIC TAPE MECHANISM : 2ZM-1R4
- BASIC CD MECHANISM : 4ZG-2AC77

- TYPE: HE, HK, HR, LH, U,
G, EE, K, EZ

SYSTEM	CD- CASSEIVER	SPEAKER	REMOTE CONTROLLER
LCX-700M	CX-SL700M	SX-SL700	RC-T515

TABLE OF CONTENTS

SPECIFICATIONS	3
PROTECTION OF EYES FROM LASER BEAM DURING SERVICING	4
PRECAUTION TO REPLACE OPTICAL BLOCK	4
ELECTRICAL MAIN PARTS LIST	5 ~ 9
IC DESCRIPTION	10 ~ 16
BLOCK DIAGRAM - 1 (MAIN / FRONT)	17 ~ 18
BLOCK DIAGRAM - 2 (TUNER : HE, HK, HR, LH, U, G)	19
BLOCK DIAGRAM - 3 (TUNER : EE, K, EZ)	20
BLOCK DIAGRAM - 4 (CD)	21 ~ 22
TRANSISTOR ILLUSTRATION	23
SCHEMATIC DIAGRAM - 1 (MAIN : HE, HK, HR, LH, U, G)	24 ~ 26
WIRING - 1 (MAIN : HE, HK, HR, LH, U, G)	27 ~ 28
IC BLOCK DIAGRAM - 1	29 ~ 30
WIRING - 2 (MAIN : HE, HK, HR, LH, U, G)	31 ~ 32
SCHEMATIC DIAGRAM - 2 (MAIN : EE, K, EZ)	34 ~ 36
WIRING - 3 (MAIN : EE, K, EZ)	37 ~ 38
IC BLOCK DIAGRAM - 2	39
FL (8-BT-179GK) GRID ASSIGNMENT / ANODE CONNECTION	40
WIRING - 4 (MAIN : EE, K, EZ)	41 ~ 42
SCHEMATIC DIAGRAM - 3 (FRONT)	43 ~ 44
WIRING - 5 (FRONT / DECK)	45 ~ 46
AD PORT INPUT LEVEL / WAVEFORM	47 ~ 48
WIRING - 6 (FRONT / DECK)	49 ~ 50
SCHEMATIC DIAGRAM - 4 (CD)	51 ~ 52
WIRING - 7 (CD)	53 ~ 54
WIRING - 8 (PT)	55
ADJUSTMENT - 1 <TUNER / DECK>	56 ~ 57
ADJUSTMENT - 2 <CD>	58 ~ 59
PRACTICAL SERVICE FIGURE	60
TEST MODE	61
CD TROUBLE-SHOOTING	62
MECHANICAL EXPLODED VIEW 1 / 1	63 ~ 64
MECHANICAL PARTS LIST 1 / 1	65
CD MECHANISM EXPLODED VIEW 1 / 2	66
CD MECHANISM PARTS LIST 1 / 2	67
CD MECHANISM EXPLODED VIEW 2 / 2	68
CD MECHANISM PARTS LIST 2 / 2	68
TAPE MECHANISM EXPLODED VIEW 1 / 1	69 ~ 70
TAPE MECHANISM PARTS LIST 1 / 1	71
SPRING APPLICATION POSITION	72
SPEAKER DISASSEMBLY INSTRUCTIONS	73
SPEAKER PARTS LIST (SX-SL700)	73
ACCESSORIES / PACKAGE LIST	74
REFERENCE NAME LIST	75

SPECIFICATIONS

<FM Tuner section>		<Compact disc player section>	
Tuning range	87.5 MHz to 108 MHz	Laser	Semiconductor laser ($\lambda=780$ nm)
Usable sensitivity(IHF)	Except EE, K, EZ: 13.2 dBf (1.3 μ V, 75 ohms) EE, K, EZ: 17.2 dBf (2.0 μ V, 75 ohms)	D-A converter	1 bit dual
		Signal-to-noise ratio	85 dB (1 kHz, 0 dB)
		Harmonic distortion	0.03% (1 kHz, 0 dB)
Antenna terminals	75 ohms (unbalanced)	Wow and flutter	Unmeasurable
<AM (MW) Tuner section>		<Speaker system SX-SL700>	
Tuning range	531 kHz to 1602 kHz (9 kHz step) 530 kHz to 1710 kHz (10 kHz step)	Cabinet type	3 way, bass reflex (Magnetic sealed type)
Usable sensitivity	350 μ V/m	Speaker	Woofer: 100 mm (4 in.) cone type Super tweeter: 20 mm (1 ³ / ₁₆ in.) ceramic type Surround speaker (Tweeter) : 60 mm (2 ³ / ₁₆ in.)
Antenna	Loop antenna	Impedance	6 ohms Surround speakers: 16 ohms
<LW Tuner section>(EE, K, EZ only)		Output sound pressure level	86 dB/W/m
Tuning range	144 kHz to 290 kHz	Dimensions (W x H x D)	165 x 286 x 245 mm (6 ¹ / ₂ x 11 ³ / ₈ x 9 ³ / ₄ in.)
Usable sensitivity	1400 μ V/m	Weight	3.0 kg (6 lbs 10 oz.)
Antenna	Loop antenna	<General>	
<Amplifier section>(Except U)		Power requirements	HE, HK, HR, LH: 120 V / 220 - 240 V AC, switchable 50/60 Hz U: 120 V AC, 60 Hz G, EE, K, EZ: 230 V AC, 50 Hz
Power output	(without connecting to the SURROUND SPEAKERS) HE, HK, LH, G: 15 W + 15 W (6 ohms, T.H.D. 10%) HR: Rated: 12 W + 12 W (6 ohms, T.H.D. 1%) Reference: 15 W + 15 W (6 ohms, T.H.D. 10%) EE, K, EZ: Rated: 12 W + 12 W (6 ohms, T.H.D. 1%, 1 kHz / DIN 45500) Reference: 15 W + 15 W (6 ohms, T.H.D. 10%, 1 kHz / DIN 45324) DIN MUSIC POWER: 32 W + 32 W	Power consumption	HE, HK, HR, LH, G: 60 W U: 50 W EE, K, EZ: 105 W
Total Harmonic distortion	0.1% (7.5 W, 1 kHz, 6 ohms)	Dimensions of main unit (W x H x D)	180 x 289.5 x 329.6 mm (7 ¹ / ₈ x 11 ¹ / ₂ x 13 in.)
<Amplifier section>(U only)		Weight of main unit	5.0 kg (11 lbs.)
Power output	FTC RULE 12 watts per channel minimum RMS, both channels driven, at 6 ohms. From 70 Hz to 20 kHz with no more than 1% Total Harmonic Distortion	• Design and specifications are subject to change without notice.	
Total Harmonic distortion	0.1% (7.5 W, 1 kHz, 6 ohms)		
<Cassette deck section>			
Track format	4 tracks, 2 channels stereo		
Frequency response	CrO ₂ tape: 50 Hz - 16000 Hz Normal tape: 50 Hz - 15000 Hz		
Signal-to-noise ratio	48 dB (CrO ₂ tape)		
Recording system	AC bias		
Heads	Recording/playback/erase head x 1		

PROTECTION OF EYES FROM LASER BEAM DURING SERVICING

This set employs laser. Therefore, be sure to follow carefully the instructions below when servicing.

WARNING!!

WHEN SERVICING, DO NOT APPROACH THE LASER EXIT WITH THE EYE TOO CLOSELY. IN CASE IT IS NECESSARY TO CONFIRM LASER BEAM EMISSION. BE SURE TO OBSERVE FROM A DISTANCE OF MORE THAN 30cm FROM THE SURFACE OF THE OBJECTIVE LENS ON THE OPTICAL PICK-UP BLOCK.



- Caution: Invisible laser radiation when open and interlocks defeated avoid exposure to beam.
- Advarsel: Usynlig laserstråling ved åbning, når sikkerhedsafbrydere er ude af funktion. Undgå udsættelse for stråling.

VAROITUS!

Laitteen Käyttäminen muulla kuin tässä käyttöohjeessa mainitulla tavalla saattaa altistaa käyt-täjän turvallisuusluokan 1 ylittävälle näkymättömälle lasersäteilylle.

WARNING!

Om apparaten används på annat sätt än vad som specificeras i denna bruksanvisning, kan användaren utsättas för osynlig laserstråling, som överskrider gränsen för laserklass 1.

CAUTION

Use of controls or adjustments or performance of procedures other than those specified herein may result in hazardous radiation exposure.

ATTENTION

L'utilisation de commandes, réglages ou procédures autres que ceux spécifiés peut entraîner une dangereuse exposition aux radiations.

ADVARSEL!

Usynlig laserstråling ved åbning, når sikkerhedsafbrydere er ude af funktion. Undgå udsættelse for stråling.

This Compact Disc player is classified as a CLASS 1 LASER product.

The CLASS 1 LASER PRODUCT label is located on the rear exterior.

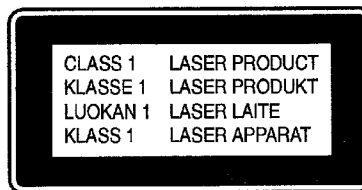

Precaution to replace Optical block

(KSS - 210A)

Body or clothes electrostatic potential could ruin laser diode in the optical block. Be sure ground body and workbench, and use care the clothes do not touch the diode.

- 1) After the connection, remove solder shown in figure below.

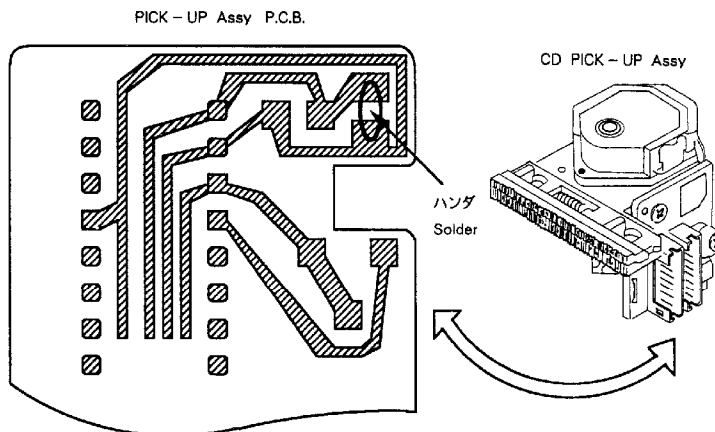

ELECTRICAL MAIN PARTS LIST

If can't understand for Description please kindly refer to "REFERENCE NAME LIST".

REF. NO.	PART NO.	KANRI NO.	DESCRIPTION	REF. NO.	PART NO.	KANRI NO.	DESCRIPTION
IC				C105	87-010-381-089		CAP,E 330-16 SME
				C106	87-010-408-089		CAP,E 47-50 SME
	87-020-454-010	IC,DM6851		C107	87-010-384-089		CAP,E 100-25 SME
	87-070-134-010	IC,TA2065F		C108	87-010-384-089		CAP,E 100-25 SME
	87-017-801-089	IC,TA2058F		C109	87-010-263-089		CAP,E 100-10 SME 5X11
	87-070-336-019	IC,TC9284BF					
	87-017-888-089	IC,NJM4558MD		C112	87-010-237-089		CAP,E 1000-16
				C113	87-010-403-089		CAP,E 3.3-50 SME
	85-CF5-641-010	IC,UPD78044BGF-015		C115	87-012-368-089		C-CAP,S 0.1-50 F<U,K,EE,EZ>
	87-070-453-010	IC,SPS-442-1		C116	87-012-140-089		C-CAP,S 470P-50 CH
	87-001-717-019	IC,STK4112-2		C118	87-012-368-089		C-CAP,S 0.1-50 F<U,K,EE,EZ>
	87-001-982-019	IC,TA7291S					
	87-017-022-089	IC,NJM2068M-D(T1)		C123	87-010-263-089		CAP,E 100-10 SME 5X11<U>
				C213	87-010-401-089		CAP,E 1-50 SME
	87-001-607-089	IC,NJM4558M		C214	87-010-401-089		CAP,E 1-50 SME
	87-020-501-089	IC,TA78L005AP		C215	87-010-181-089		C-CAP,S 1800P-50 B
	87-017-375-089	IC,TC4094BF		C216	87-010-181-089		C-CAP,S 1800P-50 B
	87-070-344-049	IC,BA3839F					
	87-002-272-089	IC,TC4052BF		C217	87-010-405-089		CAP,E 10-50 SME
				C218	87-010-405-089		CAP,E 10-50 SME
	87-070-337-019	IC,BH3854S		C223	87-010-260-089		CAP,E 47-25 SME
	87-017-698-080	IC,M65843FP<HE, HK, HR>		C224	87-010-260-089		CAP,E 47-25 SME
	87-070-127-019	IC,LC72131		C225	87-016-130-089		CAP,E 47-25 KME<EXCEPT U>
	87-017-714-019	IC,LA1836					
				C225	87-010-260-089		CAP,E 47-25 SME<U>
				C226	87-016-130-089		CAP,E 47-25 KME<EXCEPT U>
TRANSISTOR				C226	87-010-260-089		CAP,E 47-25 SME<U>
	87-026-674-010	P-TR,PT4850F		C227	87-010-193-089		C-CAP,S 0.033-25 F
	89-110-155-089	TR,2SA1015GR		C228	87-010-193-089		C-CAP,S 0.033-25 F
	89-213-702-019	TR,2SB1370E					
	87-026-609-089	TR,KTA1266GR		C231	87-018-205-089		CAP,TC-U 0.022-25 F<K,EE,EZ>
	87-026-610-089	TR,KTC3198GR		C232	87-018-205-089		CAP,TC-U 0.022-25 F<K,EE,EZ>
				C236	87-016-148-089		CAP,E 47-50 KME<EXCEPT U>
				C236	87-010-408-089		CAP,E 47-50 SME<U>
	89-327-125-089	C-TR,2SC2712GR		C237	87-010-197-089		C-CAP,S 0.01-25 B<K,EE,EZ>
	89-332-665-089	TR,2SC3266GR					
	89-111-625-089	C-TR,2SA1162GR		C238	87-010-197-089		C-CAP,S 0.01-25 B<K,EE,EZ>
	87-026-226-089	C-TR,DTA143EK		C243	87-010-154-089		C-CAP,S 10P-50CH<EXCEPT K,EE,EZ>
	89-333-266-089	C-TR,2SC3326B		C243	87-010-314-089		C-CAP,S 22P-50 CH<K,EE,EZ>
				C244	87-018-147-089		CAP,TC-U 10P-50CH<EXCEPT K,EE,EZ>
	87-026-238-089	C-TR,DTC144WK		C244	87-018-109-089		CAP,TC-U 22P-50 SL<K,EE,EZ>
	87-026-293-089	TR,DTC144WS					
	89-318-155-089	TR,2SC1815GR		C245	87-010-194-089		C-CAP,S 0.047-25 F
	89-503-655-689	FET,2SK365GR(BL)		C247	87-010-198-089		C-CAP,S 0.022-25 B
	87-026-210-089	C-TR,DTC144EK T147		C248	87-010-198-089		C-CAP,S 0.022-25 B
				C251	87-010-196-089		C-CAP,S 0.1-25 F
	89-113-187-889	TR,2SA1318TU		C252	87-018-209-089		CAP,TC-U 0.1-50 F
	87-026-211-089	C-TR,DTA144EK T147					
	89-333-317-089	TR,2SC3331T		C253	87-010-196-089		C-CAP,S 0.1-25 F<K,EE,EZ>
	89-327-126-089	C-TR,2SC2712BL<K,EE,EZ>		C313	87-010-198-089		C-CAP,S 0.022-25 B
	87-026-224-089	C-TR,DTC143XK		C315	87-010-374-089		CAP,E 47-10
				C316	87-010-374-089		CAP,E 47-10
	89-109-521-089	TR,2SA952K		C351	87-012-154-089		C-CAP,S 150P-50 CH
	89-112-965-089	TR,2SA1296GR					
	89-327-143-089	C-TR,2SC2714(O)		C352	87-012-154-089		C-CAP,S 150P-50 CH
	87-026-214-089	TR,DTA114YS		C353	87-012-140-089		C-CAP,S 470P-50 CH
	89-505-434-589	C-PET,2SK543(4/5)		C354	87-012-140-089		C-CAP,S 470P-50 CH
				C355	87-012-154-089		C-CAP,S 150P-50 CH
				C356	87-012-154-089		C-CAP,S 150P-50 CH
DIODE				C357	87-010-189-089		C-CAP,S 8200P-50 B
	87-020-465-089	DIODE,1SS133		C358	87-010-189-089		C-CAP,S 8200P-50 B
	87-002-225-019	DIODE,DBF 40C-K10		C361	87-010-197-089		C-CAP,S 0.01-25 B
	87-001-574-089	DIODE,1SR139-200 T31		C362	87-010-197-089		C-CAP,S 0.01-25 B
	87-020-027-089	C-DIODE,1SS184		C403	87-012-154-089		C-CAP,S 150P-50 CH
	87-001-916-089	ZENER,UTZJ10B					
				C404	87-012-154-089		C-CAP,S 150P-50 CH
	87-001-918-089	ZENER,UTZJ22B		C405	87-012-140-089		C-CAP,S 470P-50 CH
	87-001-914-089	ZENER,UTZJ6.2B		C406	87-012-140-089		C-CAP,S 470P-50 CH
	87-001-559-089	DIODE,1SS131(T-72)		C407	87-015-826-089		C-CAP,1200-50 BK
	87-020-125-089	C-DIODE,1SS181		C408	87-010-179-089		C-CAP,S 1200P-50 B
	87-017-091-089	ZENER,HZS5C1					
				C409	87-010-213-089		C-CAP,S 0.015-50 B
	87-002-430-089	ZENER,UTZJ8.2C		C410	87-010-213-089		C-CAP,S 0.015-50 B
	87-001-912-089	ZENER,UTZJ5.1B		C411	87-010-178-089		C-CAP,S 1000P-50 B
				C412	87-010-178-089		C-CAP,S 1000P-50 B
				C413	87-010-402-089		CAP,E 2.2-50 SME
MAIN C.B							
				C414	87-010-402-089		CAP,E 2.2-50 SME
C101	87-010-389-099	CAP,E 2200-25 SME		C415	87-010-404-089		CAP,E 4.7-50 SME
C102	87-010-390-099	CAP,E 3300-25 SME<U,K,EE,G,EZ>		C416	87-010-404-089		CAP,E 4.7-50 SME
C102	87-010-453-099	CAP,E 4700-25 SME<LH,HE,HK,HR>		C451	87-012-156-089		C-CAP,S 220P-50 CH
C104	87-010-235-089	CAP,E 470-16 SME		C452	87-012-156-089		C-CAP,S 220P-50 CH

REF. NO.	PART NO.	KANRI NO.	DESCRIPTION	REF. NO.	PART NO.	KANRI NO.	DESCRIPTION
C453	87-010-178-089		C-CAP,S 1000P-50 B	C772	87-010-194-089		C-CAP,S 0.047-25 F
C454	87-010-178-089		C-CAP,S 1000P-50 B<K,EE,EZ>	C773	87-010-196-089		C-CAP,S 0.1-25 F
C454	87-010-177-089		C-CAP,S 820P-50SL<EXCEPT K,EE,EZ>	C774	87-010-263-089		CAP,E 100-10 SME 5X11
C455	87-010-178-089		C-CAP,S 1000P-50 B<K,EE,EZ>	C775	87-010-405-089		CAP,E 10-50 SME
C455	87-010-177-089		C-CAP,S 820P-50SL<EXCEPT K,EE,EZ>	C776	87-015-819-089		CHIP CAP 0.01
C456	87-010-260-089		CAP,E 47-25 SME	C777	87-010-400-089		CAP,E 0.47-50 SME
C457	87-010-197-089		C-CAP,S 0.01-25 B	C778	87-010-401-089		CAP,E 1-50 SME
C458	87-010-183-089		C-CAP,S 2700P-50 B	C779	87-010-401-089		CAP,E 1-50 SME
C459	87-010-183-089		C-CAP,S 2700P-50 B	C780	87-010-197-089		C-CAP,S 0.01-25 B
C460	87-010-183-089		C-CAP,S 2700P-50 B	C781	87-010-401-089		CAP,E 1-50 SME
C470	87-010-196-089		C-CAP,S 0.1-25 F	C782	87-010-401-089		CAP,E 1-50 SME
C509	87-010-371-089		CAP,E 470-6.3	C785	87-012-365-089		C-CAP,S 0.027-25 BK<EXCEPT U,LH>
C521	87-010-198-089		C-CAP,S 0.022-25 B	C785	87-010-427-089		C-CAP,S 0.039-25 F<U,LH>
C522	87-010-312-089		C-CAP,S 15P-50 CH	C786	87-012-365-089		C-CAP,S 0.027-25 BK<EXCEPT U,LH>
C523	87-010-197-089		C-CAP,S 0.01-25 B	C786	87-010-427-089		C-CAP,S 0.039-25 F<U,LH>
C524	87-010-402-089		CAP,E 2.2-50 SME	C787	87-010-186-089		C-CAP,S 4700P-50 B<U,LH>
C526	87-010-545-089		CAP,E 0.22-50 SME	C788	87-010-186-089		C-CAP,S 4700P-50 B<U,LH>
C530	87-018-208-089		CAP,TC-U 0.047-50 F	C791	87-010-401-089		CAP,E 1-50 SME
C532	87-010-260-089		CAP,E 47-25 SME	C792	87-010-180-089		C-CAP,S 1500P-50B<EXCEPT K,EE,EZ>
C533	87-010-404-089		CAP,E 4.7-50 SME	C792	87-010-182-089		C-CAP,S 2200P-50 B<K,EE,EZ>
C534	87-010-404-089		CAP,E 4.7-50 SME	C793	87-010-189-089		C-CAP,S 8200P-50 B
C535	87-010-404-089		CAP,E 4.7-50 SME	C794	87-010-260-089		CAP,E 47-25 SME
C536	87-010-404-089		CAP,E 4.7-50 SME	C795	87-010-194-089		C-CAP,S 0.047-25 F
C537	87-010-196-089		C-CAP,S 0.1-25 F	C796	87-010-403-089		CAP,E 3.3-50 SME
C538	87-010-384-089		CAP,E 100-25 SME	C797	87-010-405-089		CAP,E 10-50 SME
C540	87-010-196-089		C-CAP,S 0.1-25 F	C798	87-010-196-089		C-CAP,S 0.1-25 F
C541	87-010-196-089		C-CAP,S 0.1-25 F	C799	87-015-785-089		C-CAP,0.1-25 F
C543	87-010-546-089		CAP,E 0.33-50 SME	C814	87-010-197-089		C-CAP,S 0.01-25 B
C544	87-010-546-089		CAP,E 0.33-50 SME	C816	87-010-196-089		C-CAP,S 0.1-25 F
C545	87-010-400-089		CAP,E 0.47-50 SME	C819	87-010-196-089		C-CAP,S 0.1-25 F
C546	87-010-400-089		CAP,E 0.47-50 SME	C820	87-010-260-089		CAP,E 47-25 SME
C549	87-010-186-089		C-CAP,S 4700P-50 B	C821	87-010-197-089		C-CAP,S 0.01-25 B
C550	87-010-186-089		C-CAP,S 4700P-50 B	C823	87-010-197-089		C-CAP,S 0.01-25 B
C601	87-010-404-089		CAP,E 4.7-50 SME	C826	87-010-197-089		C-CAP,S 0.01-25 B
C602	87-010-404-089		CAP,E 4.7-50 SME	C827	87-018-134-089		CAP,TC-U 0.01-16 Y<K,EE,EZ>
C603	87-010-260-089		CAP,E 47-25 SME	C840	87-010-197-089		C-CAP,S 0.01-25 B
C604	87-010-263-089		CAP,E 100-10 SME 5X11	C850	87-010-197-089		C-CAP,S 0.01-25 B
C605	87-010-196-089		C-CAP,S 0.1-25 F	C851	87-018-209-089		CAP,TC-U 0.1-50 F
C606	87-010-196-089		C-CAP,S 0.1-25 F	C941	87-010-197-089		C-CAP,S 0.01-25 B<K,EE,EZ>
C607	87-010-196-089		C-CAP,S 0.1-25 F	C942	87-010-311-089		C-CAP,S 12P-50 CH<K,EE,EZ>
C608	87-010-196-089		C-CAP,S 0.1-25 F	C944	87-010-154-089		C-CAP,S 10P-50 CH<K,EE,EZ>
C609	87-010-176-089		C-CAP,S 680P-50 SL	C944	87-010-311-089		C-CAP,S 12P-50 CH<EXCEPT K,EE,EZ>
C610	87-010-176-089		C-CAP,S 680P-50 SL	C945	87-014-050-089		CAP,PP 510P-100 J<K,EE,EZ>
C611	87-010-403-089		CAP,E 3.3-50 SME	C946	87-010-401-089		CAP,E 1-50 SME
C612	87-012-141-089		C-CAP,S 0.22-16 F	C947	87-010-197-089		C-CAP,S 0.01-25 B
C613	87-010-382-089		CAP,E 22-25 SME	C948	87-010-401-089		CAP,E 1-50 SME
C614	87-010-263-089		CAP,E 100-10 SME 5X11	C949	87-010-196-089		C-CAP,S 0.1-25 F<K,EE,EZ>
C615	87-010-198-089		C-CAP,S 0.022-25 B	C983	87-010-544-089		CAP,E 0.1-50
C616	87-010-322-089		C-CAP,S 100P-50 CH	C990	87-018-134-089		CAP,TC-U 0.01-16 Y
C682	87-010-370-089		CAP,E 330-6.3 SME	C991	87-010-401-089		CAP,E 1-50 SME
C683	87-010-197-089		C-CAP,S 0.01-25 B	CF801	87-008-423-019		CF,SFE10.7 MS3G-A<K,EE,EZ>
C684	87-010-197-089		C-CAP,S 0.01-25 B	CF801	87-008-261-019		FLTR,SFE10.7MA5-A<EXCEPT K,EE,EZ>
C685	87-012-158-089		C-CAP,S 390P-50 CH	CF802	82-785-747-019		CF,MS2 GHY R<K,EE,EZ>
C686	87-012-158-089		C-CAP,S 390P-50 CH	CF802	87-008-261-019		FLTR,SFE10.7MA5-A<EXCEPT K,EE,EZ>
C687	87-010-401-089		CAP,E 1-50 SME	FFE801	85-NF5-605-019		FE PACK 2 EX<EXCEPT K,EE,EZ>
C688	87-010-401-089		CAP,E 1-50 SME	FFE801	85-NF5-604-019		FE PACK 4(AL)<K,EE,EZ>
C696	87-010-384-089		CAP,E 100-25 SME	J250	87-099-881-019		JACK,DIA3.5 STS(2.5)
C700	87-010-196-089		C-CAP,S 0.1-25 F	J251	87-009-549-019		JACK,DIA 3.5
C701	87-010-404-089		CAP,E 4.7-50 SME	J253	81-CXC-657-019		JACK,4P-1
C702	87-010-197-089		C-CAP,S 0.01-25 B	J254	87-033-227-019		TERMINAL,SP 4P R(Z)
C703	87-010-197-089		C-CAP,S 0.01-25 B	J801	87-033-241-019		TERMINAL,ANT AJ-2039<K,EE,EZ>
C711	87-010-263-089		CAP,E 100-10 SME 5X11	J801	87-033-235-019		TERMINAL,ANT(H)<EXCEPT K,EE,EZ>
C712	87-010-112-089		CAP,E 100-16	L231	87-005-366-019		COIL,LUH<K,EE,EZ>
C720	87-015-785-089		C-CAP,0.1-25 F	L232	87-005-366-019		COIL,LUH<K,EE,EZ>
C722	87-010-152-089		C-CAP,S 8P-50 CH	L401	82-231-622-089		COIL,22MH-J
C723	87-010-178-089		C-CAP,S 1000P-50 B	L402	82-231-622-089		COIL,22MH-J
C725	87-010-178-089		C-CAP,S 1000P-50 B	L451	87-007-336-019		COIL,OSC 85K BIAS
C727	87-010-197-089		C-CAP,S 0.01-25 B	L741	87-006-321-019		COIL,FM DET SAG
C728	87-010-248-089		CAP,E 220-10 SME	L742	82-NF1-659-019		FLTR,CFAE-450 2NT
C771	87-010-405-089		CAP,E 10-50 SME	L770	87-003-102-089		COIL,10UH

REF. NO.	PART NO.	KANRI NO.	DESCRIPTION	REF. NO.	PART NO.	KANRI NO.	DESCRIPTION
L832	87-003-098-089		COIL, 2.2UH	C801	87-010-384-049		CAP, E 100-25 SME
L941	87-006-208-019		COIL, ANT LW<K, EE, EZ>	CON105	88-802-091-529		CONN ASSY, 9P
L942	87-007-305-019		COIL, OSC LW S<K, EE, EZ>	FB100	87-008-372-089		FLTR, EMI BL 01RNI
L981	82-NT3-632-019		AM PACK 1, SAG<EXCEPT K, EE, EZ>	FL101	85-CF5-650-019		FL, BT-179GK
L981	81-MX4-619-019		AM PACK 4<K, EE, EZ>	FT103	88-918-451-219		FF-CABLE, 18P 1.25
R105	87-022-050-089		RESIS, METAL 1W-0.22J	FT104	88-907-281-119		FF-CABLE, 7P 1.25
R106	87-022-050-089		RESIS, METAL 1W-0.22J	J501	82-NF7-630-019		JACK, 3.5 MO
R591	87-010-312-089		C-CAP, S 15P-50 CH<K, EE, EZ>	L701	87-005-456-089		COIL, 1000UH FLR50 K<HE, HK, HR>
R592	87-010-312-089		C-CAP, S 15P-50 CH<K, EE, EZ>	LED402	87-017-368-080		LED, SEL4514C TP5
RY101	87-045-382-019		RELAY, OVAZ-SH-112L	LED403	87-017-368-080		LED, SEL4514C TP5
SFR451	87-024-175-089		SFR, 47K DIA6 V	LED404	87-070-431-080		LED, SEL4214R TP5
SFR452	87-024-175-089		SFR, 47K DIA6 V	LED405	87-017-368-080		LED, SEL4514C TP5
SFR722	87-024-171-089		SFR, 4.7K DIA6 V	LED406	87-017-368-080		LED, SEL4514C TP5
TC721	87-011-253-089		TRIMER, 30P LAR	LED407	87-070-431-080		LED, SEL4214R TP5
TC942	87-011-253-089		TRIMER, 30P LAR<K, EE, EZ>	LED408	87-017-368-080		LED, SEL4514C TP5
W101	83-NEG-679-019		F-CABLE, 5P-2.5	LED409	87-017-368-080		LED, SEL4514C TP5
X703	84-508-618-019		VIB, CER CSB 456 F15	LED410	87-070-431-080		LED, SEL4214R TP5
X721	87-030-372-019		VIB, XTAL 7.2MHZ	LED411	87-017-368-080		LED, SEL4514C TP5
				LED412	87-017-368-080		LED, SEL4514C TP5
				LED413	87-070-431-080		LED, SEL4214R TP5
FRONT C.B							
C201	87-010-401-049		CAP, E 1-50 SME	LED414	87-070-198-089		LED, SLP736A-81-S-T1
C202	87-010-263-049		CAP, E 100-10	LED415	87-070-198-089		LED, SLP736A-81-S-T1
C203	87-010-370-049		CAP, E 330-6.3 SME	LED416	87-070-198-089		LED, SLP736A-81-S-T1
C204	87-010-196-089		C-CAP, S 0.1-25 F	LED417	87-070-198-089		LED, SLP736A-81-S-T1
C205	87-010-401-049		CAP, E 1-50 SME	LED418	87-070-198-089		LED, SLP736A-81-S-T1
C206	87-010-196-089		C-CAP, S 0.1-25 F	LED419	87-070-198-089		LED, SLP736A-81-S-T1
C207	87-010-178-089		C-CAP, S 1000P-50 B	S301	87-036-397-089		SW, TACT SKQNAB
C208	87-010-075-049		CAP, E 10-16 5L	S302	87-036-397-089		SW, TACT SKQNAB
C209	87-010-246-049		CAP, E 47-35 SME	S303	87-036-397-089		SW, TACT SKQNAB
C210	87-015-688-049		CAP, E 4.7-35 7L	S304	87-036-397-089		SW, TACT SKQNAB
C211	87-015-688-049		CAP, E 4.7-35 7L	S305	87-036-397-089		SW, TACT SKQNAB
C212	87-010-196-089		C-CAP, S 0.1-25 F	S306	87-036-397-089		SW, TACT SKQNAB
C213	87-010-314-089		C-CAP, S 22P-50 CH	S307	87-036-397-089		SW, TACT SKQNAB
C214	87-010-317-089		C-CAP, S 39P-50 CH	S308	87-036-397-089		SW, TACT SKQNAB
C215	87-010-317-089		C-CAP, S 39P-50 CH	S309	87-036-397-089		SW, TACT SKQNAB
C216	87-015-785-089		C-CAP, 0.1-25 F	S310	87-036-397-089		SW, TACT SKQNAB
C401	87-010-196-089		C-CAP, S 0.1-25 F	S311	87-036-397-089		SW, TACT SKQNAB
C403	87-010-196-089		C-CAP, S 0.1-25 F	S312	87-036-397-089		SW, TACT SKQNAB
C501	87-010-248-049		CAP, E 220-10 SME	S316	87-036-397-089		SW, TACT SKQNAB
C502	87-010-405-049		CAP, E 10-50 SME<HE, HK, HR>	S317	87-036-397-089		SW, TACT SKQNAB
C502	87-018-209-089		CAP, TC-U 0.1-50 F<K, EE, EZ>	S318	87-036-397-089		SW, TACT SKQNAB
C503	87-010-545-049		CAP E 0.22-50 SME<HE, HK, HR>	S319	87-036-397-089		SW, TACT SKQNAB
C503	87-010-544-049		CAP, E 0.1-50 SME<U, K, EE, LH, G, EZ>	S320	87-036-397-089		SW, TACT SKQNAB
C505	87-010-405-049		CAP, E 10-50 SME	S321	87-036-397-089		SW, TACT SKQNAB
C506	87-012-145-089		C-CAP, S 270P-50CH	VR501	85-CF5-661-019		VR, 20KA RK11K1130
C508	87-012-155-089		C-CAP, S 180P-50 CH	VR502	85-CF5-662-019		VR, 20KB RK11K1130<HE, HK, HR>
C509	87-010-183-089		C-CAP, S 2700P-50 B	X201	87-030-375-089		VIB, CF4.19MG200
C510	87-010-374-049		CAP, E 47-10				
C511	87-018-209-089		CAP, TC-U 0.1-50 F	CD C.B			
C513	87-010-178-089		C-CAP, S 1000P-50 B	C1	87-010-148-089		C-CAP, S 4P-50 CH
C514	87-010-176-089		C-CAP, S 680P-50 SL	C3	87-010-401-089		CAP, E 1-50 SME
C515	87-010-178-089		C-CAP, S 1000P-50 B	C6	87-010-405-089		CAP, E 10-50 SME
C530	87-010-196-089		C-CAP, S 0.1-25 F<HE, HK, HR>	C7	87-010-188-089		C-CAP, S 6800P-50 B
C531	87-010-196-089		C-CAP, S 0.1-25 F	C8	87-010-401-089		CAP, E 1-50 SME
C701	87-012-142-089		C-CAP, S 0.33-16 F	C9	87-010-406-089		CAP, E 22-50 SME
C702	87-015-695-049		CAP, E 1-50 7L<HE, HK, HR>	C10	87-010-403-089		CAP, E 3.3-50 SME
C703	87-015-785-089		C-CAP, 0.1-25 F<HE, HK, HR>	C13	87-010-401-089		CAP, E 1-50 SME
C704	87-010-188-089		C-CAP, S 6800P-50 B<HE, HK, HR>	C16	87-010-318-089		C-CAP, S 47P-50 CH
C705	87-010-177-089		C-CAP, S 820P-50 SL<HE, HK, HR>	C18	87-010-263-089		CAP, E 100-10 SME 5X11
C706	87-010-196-089		C-CAP, S 0.1-25 F<HE, HK, HR>	C19	87-018-134-089		CAP, TC-U 0.01-16 Y
C707	87-010-260-049		CAP, E 47-25 SME<HE, HK, HR>	C20	87-010-263-089		CAP, E 100-10 SME 5X11
C710	87-010-196-089		C-CAP, S 0.1-25 F<HE, HK, HR>	C21	87-010-197-089		C-CAP, S 0.01-25 B
C711	87-010-188-089		C-CAP, S 6800P-50 B<HE, HK, HR>	C22	87-010-263-089		CAP, E 100-10 SME 5X11
C712	87-010-184-089		C-CAP, S 3300P-50 B<HE, HK, HR>	C23	87-010-263-089		CAP, E 100-10 SME 5X11
C713	87-010-196-089		C-CAP, S 0.1-25 F<HE, HK, HR>	C24	87-010-263-089		CAP, E 100-10 SME 5X11
C714	87-012-140-089		C-CAP, S 470P-50 CH<HE, HK, HR>	C25	87-010-197-089		C-CAP, S 0.01-25 B
C715	87-012-140-089		C-CAP, S 470P-50 CH<HE, HK, HR>	C26	87-010-263-089		CAP, E 100-10 SME 5X11
C716	87-010-374-049		CAP, E 47-10<HE, HK, HR>	C51	87-010-196-089		C-CAP, S 0.1-25 F
C717	87-010-198-089		C-CAP, S 0.022-25 B<HE, HK, HR>	C52	87-010-196-089		C-CAP, S 0.1-25 F
C718	87-010-263-049		CAP, E 100-10<HE, HK, HR>				

REF. NO.	PART NO.	KANRI NO.	DESCRIPTION	REF. NO.	PART NO.	KANRI NO.	DESCRIPTION
C53	87-010-196-089		C-CAP,S 0.1-25 F	LED424	87-070-432-080		LED,SEL4414G TP5
C54	87-010-196-089		C-CAP,S 0.1-25 F	LED425	87-070-432-080		LED,SEL4414G TP5
C57	87-010-197-089		C-CAP,S 0.01-25 B	LED426	87-070-432-080		LED,SEL4414G TP5
C58	87-010-221-089		CAP,E 470-10	S322	87-036-397-089		SW,TACT SKQNAB
C59	87-010-263-089		CAP,E 100-10 SME 5X11	S323	87-036-397-089		SW,TACT SKQNAB
C60	87-010-197-089		C-CAP,S 0.01-25 B	S324	87-036-397-089		SW,TACT SKQNAB
C61	87-010-263-089		CAP,E 100-10 SME 5X11	S325	87-036-397-089		SW,TACT SKQNAB
C101	87-010-178-089		C-CAP,S 1000P-50 B	S326	87-036-397-089		SW,TACT SKQNAB
C102	87-010-186-089		C-CAP,S 4700P-50 B	S327	87-036-397-089		SW,TACT SKQNAB
C105	87-018-119-089		CAP,TC-U 100P-50 B	S328	87-036-397-089		SW,TACT SKQNAB
C106	87-010-197-089		C-CAP,S 0.01-25 B	S329	87-036-397-089		SW,TACT SKQNAB
C107	87-010-197-089		C-CAP,S 0.01-25 B	S330	87-036-397-089		SW,TACT SKQNAB
C109	87-010-314-089		C-CAP,S 22P-50 CH				
C110	87-010-314-089		C-CAP,S 22P-50 CH				
C111	87-010-197-089		C-CAP,S 0.01-25 B				LED-1 C.B
C112	87-015-819-089		CHIP CAP 0.01	D901	87-070-129-080		LED,SEL1450CEM
C113	87-010-263-089		CAP,E 100-10 SME 5X11	D902	87-017-733-080		LED,SEL1250SM
C114	87-018-134-089		CAP,TC-U 0.01-16 Y	D903	87-017-733-080		LED,SEL1250SM
C115	87-010-263-089		CAP,E 100-10 SME 5X11	D904	87-070-129-080		LED,SEL1450CEM
C116	87-010-404-089		CAP,E 4.7-50 SME				
C117	87-018-209-089		CAP,TC-U 0.1-50 F				AC C.B
C121	87-010-263-089		CAP,E 100-10 SME 5X11				
C201	87-012-153-089		C-CAP,S 120P-50 CH				
C202	87-012-153-089		C-CAP,S 120P-50 CH				PT C.B
C203	87-012-153-089		C-CAP,S 120P-50 CH				
C204	87-012-153-089		C-CAP,S 120P-50 CH				
C205	87-012-153-089		C-CAP,S 120P-50 CH				
C206	87-012-153-089		C-CAP,S 120P-50 CH				
C207	87-012-153-089		C-CAP,S 120P-50 CH				
C208	87-012-153-089		C-CAP,S 120P-50 CH				
C209	87-012-153-089		C-CAP,S 120P-50 CH				
C210	87-012-153-089		C-CAP,S 120P-50 CH				
C211	87-010-401-089		CAP,E 1-50 SME				
C212	87-010-401-089		CAP,E 1-50 SME				
C213	87-010-186-089		C-CAP,S 4700P-50 B				
C214	87-010-186-089		C-CAP,S 4700P-50 B				DECK C.B
C251	87-010-101-089		CAP,E 220-16 SME	SFR1	87-024-581-010		SFR,3.3K DIA 6H KOA
C252	87-010-263-089		CAP,E 100-10 SME 5X11	SOL2	82-2M1-618-310		SOL ASSY,27
C301	87-018-119-089		CAP,TC-U 100P-50 B	SW2	87-036-110-010		SW,PUSH SPPB 62
C302	87-018-119-089		CAP,TC-U 100P-50 B	SW3	87-036-110-010		SW,PUSH SPPB 62
				SW4	87-036-110-010		SW,PUSH SPPB 62
C303	87-018-119-089		CAP,TC-U 100P-50 B				
C304	87-018-119-089		CAP,TC-U 100P-50 B				
C305	87-018-119-089		CAP,TC-U 100P-50 B	SW5	87-036-110-010		SW,PUSH SPPB 62
C306	87-018-119-089		CAP,TC-U 100P-50 B	SW6	87-036-110-010		SW,PUSH SPPB 62
C351	87-010-384-089		CAP,E 100-25 SME				
C352	87-010-197-089		C-CAP,S 0.01-25 B				RELAY C.B
C353	87-010-197-089		C-CAP,S 0.01-25 B				
C354	87-010-197-089		C-CAP,S 0.01-25 B				
C402	87-010-197-089		C-CAP,S 0.01-25 B				
C403	87-010-404-089		CAP,E 4.7-50 SME	CON151	85-CF5-660-019		CONN ASSY,8P-RPB
C404	87-010-248-089		CAP,E 220-10 SME				MOTOR-1 C.B
C406	87-010-263-089		CAP,E 100-10 SME 5X11	M20	9X-262-513-210		SLED MOTOR ASSY
CON5	88-802-081-699		CONN ASSY,8P	M21	9X-262-513-210		SPINDLE MOTOR ASSY
CON51	88-802-081-429		CONN ASSY,8P	PIN105	91-564-722-110		CONNECTOR 6P
FT101	88-906-201-119		FF-CABLE,6P 1.25	SW1	91-572-085-110		LEAF SW
FT102	88-914-141-119		FF-CABLE,14P 1.25				MOTOR C.B
L1	87-003-102-089		COIL,10UH				
SFR1	87-024-172-089		SFR,10K DIA6 V	C11	87-016-271-080		CAP,E 22-16 BP
SFR2	87-024-176-089		SFR,100K DIA6 V	M11	87-045-383-010		MOT,M9I T2
SFR3	87-024-176-089		SFR,100K DIA6 V				
SFR4	87-024-176-089		SFR,100K DIA6 V				CONNECTOR C.B
X101	87-030-221-089		CERALOCK 16.93MHZ				
				C1	87-016-271-080		CAP,E 22-16 BP
				C2	87-016-271-080		CAP,E 22-16 BP
				M1	87-045-383-010		MOT,M9I T2
				M2	87-045-383-010		MOT,M9I T2
				SW1	87-036-109-010		SW,PUSH SPPB 61
				SW2	87-036-109-010		SW,PUSH SPPB 61
				SW3	87-036-252-010		SW,PUSH SPPB 51
				W1	84-2G2-610-010		F-CABLE 2.0-2P L=150
KEY C.B							
C402	87-010-196-089		C-CAP,S 0.1-25 F				
LED420	87-070-432-080		LED,SEL4414G TP5				
LED421	87-070-432-080		LED,SEL4414G TP5				
LED422	87-070-432-080		LED,SEL4414G TP5				
LED423	87-070-432-080		LED,SEL4414G TP5				

REF. NO.	PART NO.	KANRI NO.	DESCRIPTION
SENSOR C.B			
W2	84-ZG2-612-010		CABLE,FFC 4P L=225
LED C.B			
LED41	83-XA2-672-010		LED,SID1010CM
LED42	83-XA2-672-010		LED,SID1010CM
PH C.B			
PH21	87-026-573-010		P-SNSR,GP1853V

○ チップ抵抗部品コード / CHIP RESISTOR PART CODE

チップ抵抗部品コードの成り立ち
Chip Resistor Part Coding

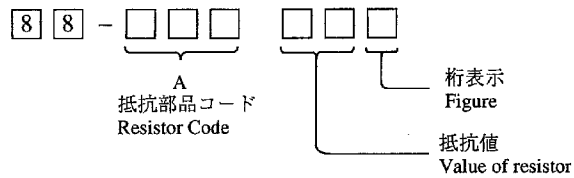

チップ抵抗
Chip resistor

Wattage 容量	Type 種類	Tolerance 許容誤差	Symbol 記号	Dimensions / 寸法 (mm)			Resistor Code: A 抵抗コード : A	
				Form / 外形	L	W		t
1/32W	1608	±5%	CJ		1.6	0.8	0.35	108
1/10W	2125	±5%	CJ		2	1.25	1.45	118
1/8W	3216	±5%	CJ		3.2	1.6	0.5 ~0.7	128

IC DESCRIPTION

IC, TC9284BF

Pin No.	Pin Name	I/O	Description
1	GND A	-	Analog ground terminal for D/A converter (Right channel).
2	RO	O	Right channel data forward output terminal.
3	\overline{RO}	O	Right channel data reverse output terminal.
4	VDA	-	Analog power supply terminal for D/A converter (+5V).
5	\overline{LO}	O	Left channel data reverse output terminal.
6	LO	O	Left channel data forward output terminal.
7	GND A	-	Analog ground terminal for D/A converter (Left channel).
8	$\overline{TEST3}$	I	Test terminal. Normally, keep at "H" level or open.
9	$\overline{TEST4}$		
10	$\overline{TEST5}$		
11	SBOK	O	Subcode Q data CRC check adjusting result output terminal. The adjusting result is OK at "H" level. (Not used)
12	VDDD	-	Digital supply voltage terminal (+5V).
13	GNDD	-	Digital ground terminal.
14 ~ 17	BUS0 ~ BUS3	I / O	Command and data sending / receiving input / output terminals.
18	\overline{CCE}	I	Command and data sending / receiving chip enable signal input terminal. The bus line becomes active at "L" level.
19	BUCK	I	Command and data sending / receiving clock input terminal.
20	PFCK	O	Regeneration system frame periodic signal output terminal (7.35kHz). (Not used)
21	\overline{RST}	I	Reset input terminal. The internal system is reset at "L" level.
22	SUBSYC	O	Subcode sync signal output terminal. (Not used)
23	SUBD	O	Subcode P ~ W output terminals. (Not used)
24	CLCK	I	Subcode P ~ W data readout clock input terminal.
25	VDDD	-	Digital supply voltage terminal (+5V).
26	GNDD	-	Digital ground terminal.
27	DFCT	O	Defect detection signal output terminal. VREF when defect is detected. Normally, HiZ. (Not used)
28	TEL2	O	Tracking gain adjusting analog switch output terminals. VREF or HiZ.
29	TEL1		
30	TGUL	O	Tracking servo loop low frequency phase compensator change-over analog switch output terminal. HiZ (gain up) when detecting shock. Normally, VREF.
31	TGUH2	O	Tracking servo loop middle / high frequency phase compensator change-over analog switch output terminals. HiZ (gain up) when detecting shock. Normally, VREF. TGUH1 is used at normal regeneration and TGUH2 is used at double speed regeneration.
32	TGUH1		
33	TKIC	O	Tracking actuator kick signal output terminal. Kicks in the outer circumferential direction at "H" level and in the inner circumferential direction at "L" level.
34	FMON	O	Feed servo ON / OFF analog switch output terminals. Servo on at "HiZ" and off at "VREF".
35	$\overline{TEST1}$	I	Test terminal. Normally, keep at "H" level or open.

Pin No.	Pin Name	I/O	Description																
36	FMPB	O	Feed motor FWD / BWD feeding control signal output terminal. Feed in the outer circumferential direction at "H" level and in the inner circumferential direction at "L" level.																
37	TEST	I	Test terminal. Normally, keep at "H" level or open. (Not used)																
38	DMON	O	Disc motor driving circuit gain change-over analog switch output terminal.																
39	DMFO	O	Disc motor CLV servo AFC signal output terminal. <table border="1" style="margin-left: 20px;"> <thead> <tr> <th>COMMAND</th> <th>DMFC OUTPUT</th> <th>OPERATION</th> </tr> </thead> <tbody> <tr> <td>DMFK</td> <td>H</td> <td>Motor acceleration</td> </tr> <tr> <td>DMSV</td> <td>PWM</td> <td>CLV servo ON</td> </tr> <tr> <td>DMBK</td> <td>L</td> <td>Motor deceleration</td> </tr> <tr> <td>DMOFF</td> <td>VREF</td> <td>CLV servo OFF</td> </tr> </tbody> </table>	COMMAND	DMFC OUTPUT	OPERATION	DMFK	H	Motor acceleration	DMSV	PWM	CLV servo ON	DMBK	L	Motor deceleration	DMOFF	VREF	CLV servo OFF	
COMMAND	DMFC OUTPUT	OPERATION																	
DMFK	H	Motor acceleration																	
DMSV	PWM	CLV servo ON																	
DMBK	L	Motor deceleration																	
DMOFF	VREF	CLV servo OFF																	
40	DMPC	O	Disc motor CLV servo APC signal output terminal.																
41	2VREF	I	Double times reference voltage input terminal (VREF X 2).																
42	SEL	O	Servo mode indicating signal output terminal. <table border="1" style="margin-left: 20px;"> <thead> <tr> <th>SEL</th> <th>LD ON / OFF</th> <th>FOCUS SERVO</th> <th>OPERATION</th> </tr> </thead> <tbody> <tr> <td>L</td> <td>OFF</td> <td>OFF</td> <td>LD OFF</td> </tr> <tr> <td>HiZ</td> <td>ON</td> <td>OFF</td> <td>Focus Search</td> </tr> <tr> <td>H</td> <td>ON</td> <td>ON</td> <td>Normal play etc. Focus Servo ON: FOK</td> </tr> </tbody> </table>	SEL	LD ON / OFF	FOCUS SERVO	OPERATION	L	OFF	OFF	LD OFF	HiZ	ON	OFF	Focus Search	H	ON	ON	Normal play etc. Focus Servo ON: FOK
SEL	LD ON / OFF	FOCUS SERVO	OPERATION																
L	OFF	OFF	LD OFF																
HiZ	ON	OFF	Focus Search																
H	ON	ON	Normal play etc. Focus Servo ON: FOK																
43	FCSI	O	Focus actuator driving signal output terminal in the focus search mode. <table border="1" style="margin-left: 20px;"> <thead> <tr> <th>COMMAND</th> <th>FCSI OUTPUT</th> <th>OPERATION</th> </tr> </thead> <tbody> <tr> <td>FORST</td> <td>H</td> <td>Lens gets far away from disc</td> </tr> <tr> <td>FOSET</td> <td>L</td> <td>Lens gets near disc</td> </tr> <tr> <td>Others</td> <td>HiZ</td> <td>Other than focus search</td> </tr> </tbody> </table>	COMMAND	FCSI OUTPUT	OPERATION	FORST	H	Lens gets far away from disc	FOSET	L	Lens gets near disc	Others	HiZ	Other than focus search				
COMMAND	FCSI OUTPUT	OPERATION																	
FORST	H	Lens gets far away from disc																	
FOSET	L	Lens gets near disc																	
Others	HiZ	Other than focus search																	
44	FKIC	O	Focus actuator driving signal output terminal in the focus gain adjusting mode. <table border="1" style="margin-left: 20px;"> <thead> <tr> <th>COMMAND</th> <th>FKIC OUTPUT</th> <th>OPERATION</th> </tr> </thead> <tbody> <tr> <td>FGASR</td> <td>H</td> <td>Lens gets far away from disc</td> </tr> <tr> <td>FGASS</td> <td>L</td> <td>Lens gets near disc</td> </tr> <tr> <td>Others</td> <td>HiZ</td> <td>Other than focus adjustment</td> </tr> </tbody> </table>	COMMAND	FKIC OUTPUT	OPERATION	FGASR	H	Lens gets far away from disc	FGASS	L	Lens gets near disc	Others	HiZ	Other than focus adjustment				
COMMAND	FKIC OUTPUT	OPERATION																	
FGASR	H	Lens gets far away from disc																	
FGASS	L	Lens gets near disc																	
Others	HiZ	Other than focus adjustment																	
45	FEL2	O	Focus gain adjusting analog switch output terminals. (Not used)																
46	FEL1																		
47	FEI	I	Focus error signal input terminal.																
48	TESH	I	Tracking error signal input sample holding analog switch input terminal.																
49	TEOF	O	Tracking servo operation ON / OFF analog switch output terminal. VREF when the tracking servo is OFF.																
50	SBAD	I	Sub-beam adding signal input terminal.																
51	RFRP	I	RF ripple signal input terminal.																
52	VREF	I	Reference voltage input terminal (+2.1V).																
53	RFI	I	RF signal input terminal.																
54	GNDA	-	Analog ground terminal.																
55	DTSC2	O	Data slice control EFM signal passive output terminal.																

Pin No.	Pin Name	I/O	Description								
56	MONIT	O	Internal signal (EFMO, PLCK, LOCK and MBOV) output terminal. Selected by command. (Not used)								
57	DTSC1	O	Data slice control EFM signal negative output terminal.								
58	VDDA	-	Analog supply voltage terminal (+5V).								
59	PDCNT	I	PDO output control terminal. At "L" level, PDO output is made to HiZ by force.								
60	PDO	O	Phase error signal output terminal between EFM signal and PLCK.								
61	TMAX	O	TMAX signal output terminal. HiZ at time of system clock.								
			<table border="1"> <thead> <tr> <th>TMAX PERIOD</th> <th>TMAX OUTPUT</th> </tr> </thead> <tbody> <tr> <td>Longer than specified period</td> <td>L</td> </tr> <tr> <td>Shorter than specified period</td> <td>H (2VREF)</td> </tr> <tr> <td>Specified period</td> <td>HiZ</td> </tr> </tbody> </table>	TMAX PERIOD	TMAX OUTPUT	Longer than specified period	L	Shorter than specified period	H (2VREF)	Specified period	HiZ
			TMAX PERIOD	TMAX OUTPUT							
			Longer than specified period	L							
Shorter than specified period	H (2VREF)										
Specified period	HiZ										
62	LPFN	I	LPF amplifier inverting input terminal for PLL.								
63	LPFO	O	LPF amplifier output terminal for PLL.								
64	VCOF	I	VCO filter terminal.								
65	TESTX	I	Test terminal. (Connected to GNDD)								
66	HS	O	Double speed monitor output terminal. Double speed operation at "L" level. (Not used)								
67	GNDD	-	Digital ground terminal.								
68	SPDA	O	Processor status signal output terminal. Correction process judging result, memory buffer capacity, etc. (Not used)								
69	COFS	O	Correction system frame periodic signal output terminal (7.35kHz). (Not used)								
70	WDCK	O	Word clock output terminal. Normally, 88.2kHz. (Not used)								
71	CHCK	O	Channel clock output terminal. Normally, 44.1kHz. (Not used)								
72	BCK	O	Bit clock output terminal. Normally, 1.4112MHz. (Not used)								
73	AOUT	O	Audio data output terminal. (Not used)								
74	EMPH	O	Emphasis ON / OFF indication signal output terminal. Emphasis ON at "H" level. (Not used)								
75	DOUT	O	Digital out output terminal. (Not used)								
76	TEST2	I	Test terminal. Normally, keep at "H" level or open.								
77	VDDX	O	Oscillator supply voltage terminal (+5V).								
78	XI	I	Crystal oscillator connecting terminal.								
79	XO	O									
80	GNDX	O	Oscillator ground terminal.								

NOTE : HiZ = High Impedance

IC, TA2065F

Pin No.	Pin Name	I/O	Description
1	RFO	O	RF amplifier (RF AMP) output terminal.
2	RFI	I	RF ripple signal generating circuit input terminal.
3	VRO	O	VR amplifier output terminal.
4	2VRO	O	2VR amplifier output terminal.
5	RFRP	O	RF ripple signal output terminal.
6	SBAD	O	Defects detection signal output terminal.
7	DFIN	I	Defects detecting comparator positive phase input terminal. (Connected to SBAD)
8	FEP	I	Focus error balance adjusting input terminal.
9	FEN	I	Focus error amplifier (FE AMP) negative phase input terminal.
10	FEO	O	Focus error amplifier (FE AMP) output terminal.
11	FEI	I	Focus output amplifier (FS AMP) positive phase input terminal.
12	FHLD	I	Hold switch terminal for defect.
13	FEL1	I	Focus gain adjusting terminal. (Not used)
14	FEL2		
15	FSN	I	Focus output amplifier (FS AMP) negative phase input terminal.
16	FSO	O	Focus output amplifier (FS AMP) output terminal.
17	COSC	O	Focus search signal generating capacitor connecting terminal.
18	OSCI	I	Focus search signal generating built-in current source control input terminal.
19	GND	–	Ground terminal.
20	VCC	–	Power source terminal (+5V).
21	SEL	I	Analog switch control signal input terminal.
22	DMEP	I	Disc motor amplifier (DM AMP) positive phase input terminal.
23	DMEN	I	Disc motor amplifier (DM AMP) negative phase input terminal.
24	DMEO	O	Disc motor amplifier (DM AMP) output terminal.
25	DFCT	I	Defect detecting comparator negative phase input terminal.
26	FMSO	O	Feed motor output amplifier (FMS AMP) output terminal.
27	FMSN	I	Feed motor output amplifier (FMS AMP) negative phase input terminal.
28	FMSP	I	Feed motor output amplifier (FMS AMP) positive phase input terminal.
29	THLD	I	Hold switch terminal for defect.
30	TS2O	O	Tracking servo amplifier 2 (TS2 AMP) output terminal.
31	TS2N	I	Tracking servo amplifier 2 (TS2 AMP) negative phase input terminal.
32	TS2P	I	Tracking servo amplifier 2 (TS2 AMP) positive phase input terminal.
33	TS1N	I	Tracking servo amplifier 1 (TS1 AMP) negative phase input terminal. (Not used)
34	TS1P	I	Tracking servo amplifier 1 (TS1 AMP) positive phase input terminal.
35	TSO	O	Tracking output amplifier (TS AMP) output terminal.
36	TEL1	I	Tracking gain adjusting terminal.
37	TEL2		
38	TSN	I	Tracking output amplifier (TS AMP) negative phase input terminal.
39	TPO	O	Sub-beam I-V amplifier output terminal.
40	TPI	I	Sub-beam I-V amplifier input terminal.
41	TNI		

Pin No.	Pin Name	I/O	Description
42	TNO	O	Sub-beam I-V amplifier output terminal.
43	FNI	I	Main-beam I-V amplifier input terminal.
44	FPI		
45	LDO	O	Laser diode amplifier output terminal.
46	MDI	I	Monitor photo diode amplifier input terminal.
47	RFN	I	RF amplifier negative phase input terminal.
48	RFT	I	RF amplifier peaking terminal.

IC, LC72131

Pin No.	Pin Name	I/O	Description																								
1	XIN	-	A crystal oscillator (7.2MHz) is connected between these pins.																								
22	XOUT																										
2	NC	-	Not used.																								
3	CE	I	To enable the IC. Active "H".																								
4	DI	I	Digital data input from CPU (μ PD78044BGF-015) when relevant key is operated. Active "H".																								
5	CLK	I	To clock in the data DI.																								
6	DO	O	Digital data output to CPU (μ PD78044BGF-015).																								
7	TM-BASE	O	Outputs a reference clock signal (8Hz) for the clock.																								
8	MONO / BEAT	O	Outputs "H" when MONO / BEAT is switched.																								
9	$\overline{\text{FM}} / \text{AM}$	O	Output "L" or "H" as follows: <table border="1" style="margin-left: auto; margin-right: auto;"> <thead> <tr> <th colspan="2">2 BAND</th> <th colspan="3">3 BAND</th> <th colspan="3">3 BAND</th> </tr> <tr> <th>AM</th> <th>FM</th> <th>LW</th> <th>MW</th> <th>FM</th> <th>MW</th> <th>SW</th> <th>FM</th> </tr> </thead> <tbody> <tr> <td>H</td> <td>L</td> <td>H</td> <td>H</td> <td>L</td> <td>H</td> <td>L</td> <td>L</td> </tr> </tbody> </table>	2 BAND		3 BAND			3 BAND			AM	FM	LW	MW	FM	MW	SW	FM	H	L	H	H	L	H	L	L
2 BAND		3 BAND			3 BAND																						
AM	FM	LW	MW	FM	MW	SW	FM																				
H	L	H	H	L	H	L	L																				
10	$\overline{\text{MW}}$	O	Outputs "L" or "H" as follows: <table border="1" style="margin-left: auto; margin-right: auto;"> <thead> <tr> <th colspan="2">2 BAND</th> <th colspan="3">3 BAND</th> <th colspan="3">3 BAND</th> </tr> <tr> <th>AM</th> <th>FM</th> <th>LW</th> <th>MW</th> <th>FM</th> <th>MW</th> <th>SW</th> <th>FM</th> </tr> </thead> <tbody> <tr> <td>L</td> <td>L</td> <td>H</td> <td>L</td> <td>L</td> <td>L</td> <td>H</td> <td>L</td> </tr> </tbody> </table>	2 BAND		3 BAND			3 BAND			AM	FM	LW	MW	FM	MW	SW	FM	L	L	H	L	L	L	H	L
2 BAND		3 BAND			3 BAND																						
AM	FM	LW	MW	FM	MW	SW	FM																				
L	L	H	L	L	L	H	L																				
11	IF-MUTE	O	To control internal counter.																								
12	IFIN	I	General purpose counter input.																								
13	$\overline{\text{TUNE}}$	I	Receives "L" when station is tuned.																								
14	NC	-	Not used.																								
15	AMIN	I	Receives the AM local oscillator frequency signal.																								
16	FMIN	I	Receives the FM local oscillator frequency signal.																								
17	VDD	-	Supply power to IC (+5V).																								
18	PD	O	PLL charge pump output.																								
19	AIN	I	Nch MOS transistor for PLL active low pass filter.																								
20	AOUT	O																									
21	VSS	-	Ground.																								

IC, μ PD78044BGF-015

Pin No.	Pin Name	I/O	Description
1 ~ 7	O-G7 ~ O-G1	O	FL display grid output.
8	VDD	-	Connected to +5.6V.
9	IO-BUS3	I / O	CD IC control data bus input / output.
10	IO-BUS2		
11	IO-BUS1		
12	IO-BUS0		
13	$\overline{\text{I-STEREO}}$ / $\overline{\text{O-CCE}}$	I / O	Tuner stereo detection input / CD IC control chip enable output.
14	$\overline{\text{I-TU}}$ / IFC / O-BUCK	I / O	Tuner / IF count data input / CD IC control data bus clock output.
15	O-PLLCE	O	PLL IC chip enable output.
16	$\overline{\text{I-HOLD}}$	I	Power-down detection input. Backup mode at "L" input.
17	$\overline{\text{RESET}}$	I	Reset input.
18	O-DATA (F / M)	O	Front main shift register / PLL data output.
19	O-CLK (F / M)	O	Front main shift register / PLL clock output.
20	AVSS	-	Connected to GND.
21	I-KEY1	I	Keys 1 AD input.
22	I-KEY2	I	Keys 2 AD input.
23	I-MIC	I	Mic level AD input for auto vocal fader.
24	I-MS	I	Cassette deck MS detection AD input.
25	I-CDSW1	I	CD mecha switch 1 AD input.
26	I-CDSW2	I	CD mecha switch 2 AD input.
27	I-DISC1	I	Disc sensor 1 AD input.
28	I-DISC2	I	Disc sensor 2 AD input.
29	AVDD	-	Connected to +5.6V.
30	AVREF		
31	I-TMBASE	I	Clock reference input (exclusive for 8MHz).
32	XT2	-	Sub-clock. (Not used)
33	VSS1	-	Connected to GND.
34	X1	-	4.19MHz oscillation circuit.
35	X2		
36	O-CSHIFT	O	Micro-computer clock shift output. (See table-1)
37	$\overline{\text{O-MOTOR}}$	O	Deck motor $\overline{\text{ON}}$ / OFF output.
38	$\overline{\text{O-SOL}}$	O	Deck plunger $\overline{\text{ON}}$ / OFF output.
39	O-STB	O	Shift register data latched strobe output.
40	$\overline{\text{O-POWER}}$	O	System power $\overline{\text{ON}}$ / OFF output.
41	O-MUTE	O	System mute ON / $\overline{\text{OFF}}$ output.
42	O-OPEN	O	CD tray open output.
43	O-CLOSE	O	CD tray close output.
44	O-CHACK DN	O	Disc chacking down output.
45	O-CHACK UP	O	Disc chacking up output.

Pin No.	Pin Name	I/O	Description
46	I-BOXCNT	I	Disc box count input.
47	I-RMC	I	System remote control input. Active "L".
48	VSS2	-	Connected to GND.
49	O-CDON	O	CD power ON / OFF output.
50	O-BIAS	O	Cassette deck bias ON / OFF output.
51	O-RMT	O	REC muting output. Active "H".
52	VDD	-	Connected to +5.6V.
53	O-BOX DN	O	Disc box motor down output.
54	O-BOX UP	O	Disc box motor up output.
55 ~ 56	O-P1 ~ O-P2	O	FL segment output P1 ~ P2.
57	O-P3 / I-REBSW	O / I	FL segment output P3 / Deck B side recording permission switch input.
58	O-P4 / I-REASW	O / I	FL segment output P4 / Deck A side recording permission switch input.
59	O-P5 / I-CST SW	O / I	FL segment output P5 / Deck cassette detection switch input.
60	O-P6 / I-AUTO	O / I	FL segment output P6 / Deck auto stop input.
61	O-P7 / I-CAM SW	O / I	FL segment output P7 / Deck cam switch input.
62 ~ 63	O-P8 ~ O-P9	O	FL segment output P8 ~ P9.
64	O-P10 / I-AM10K	O / I	FL segment output P10 / MW 10kHz initial diode input.
65	O-P11 / I-LW	O / I	FL segment output P11 / LW support diode input.
66 ~ 70	O-P12 ~ O-P16	O	FL segment output P12 ~ P16.
71	VP	-	Connected to -22V.
72 ~ 77	O-P17 ~ O-P22	O	FL segment output P17 ~ P22.
78	O-SWSCAN	O	Segment input permission output.
79	O-EVRSTB	O	Electronic volume data latch output.
80	O-G8	O	FL display grid output.

Table-1

* C-SHIFT output become "H" before outputting the data to PLL at below the FM frequency range in order to reduce the FM tuning interfere.

	Frequency range	Received step
FM (OIRT)	66.93 ~ 67.28 MHz	10KHz
	71.12 ~ 71.48 MHz	
FM	79.45 ~ 79.90 MHz	50KHz
	83.65 ~ 84.10 MHz	
	87.85 ~ 88.30 MHz	
	92.00 ~ 92.50 MHz	
	96.20 ~ 96.75 MHz	
	100.40 ~ 100.95 MHz	
	104.55 ~ 105.15 MHz	

BLOCK DIAGRAM - 1 (MAIN / FRONT)

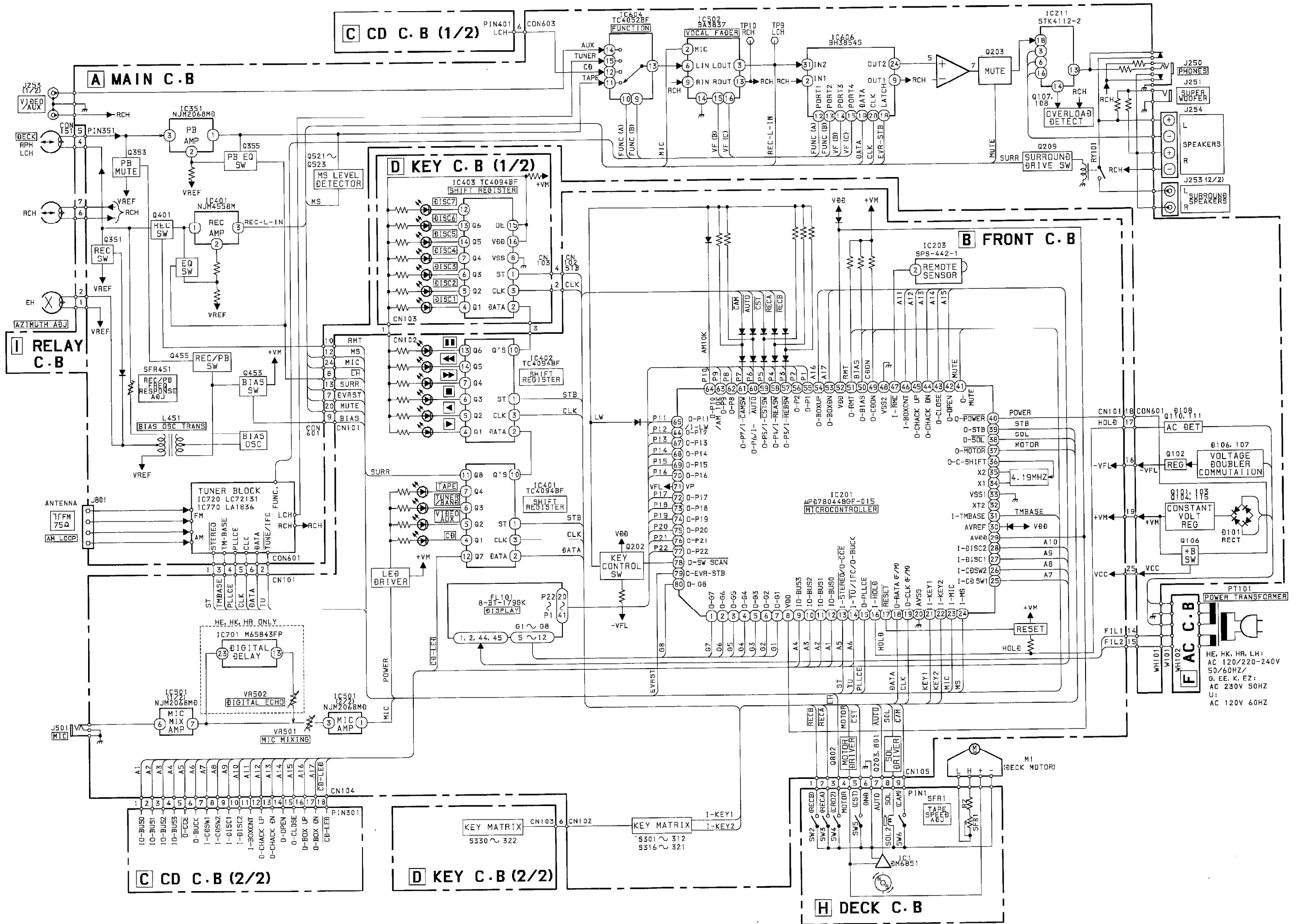

BLOCK DIAGRAM - 3 (TUNER : EE, K, EZ)

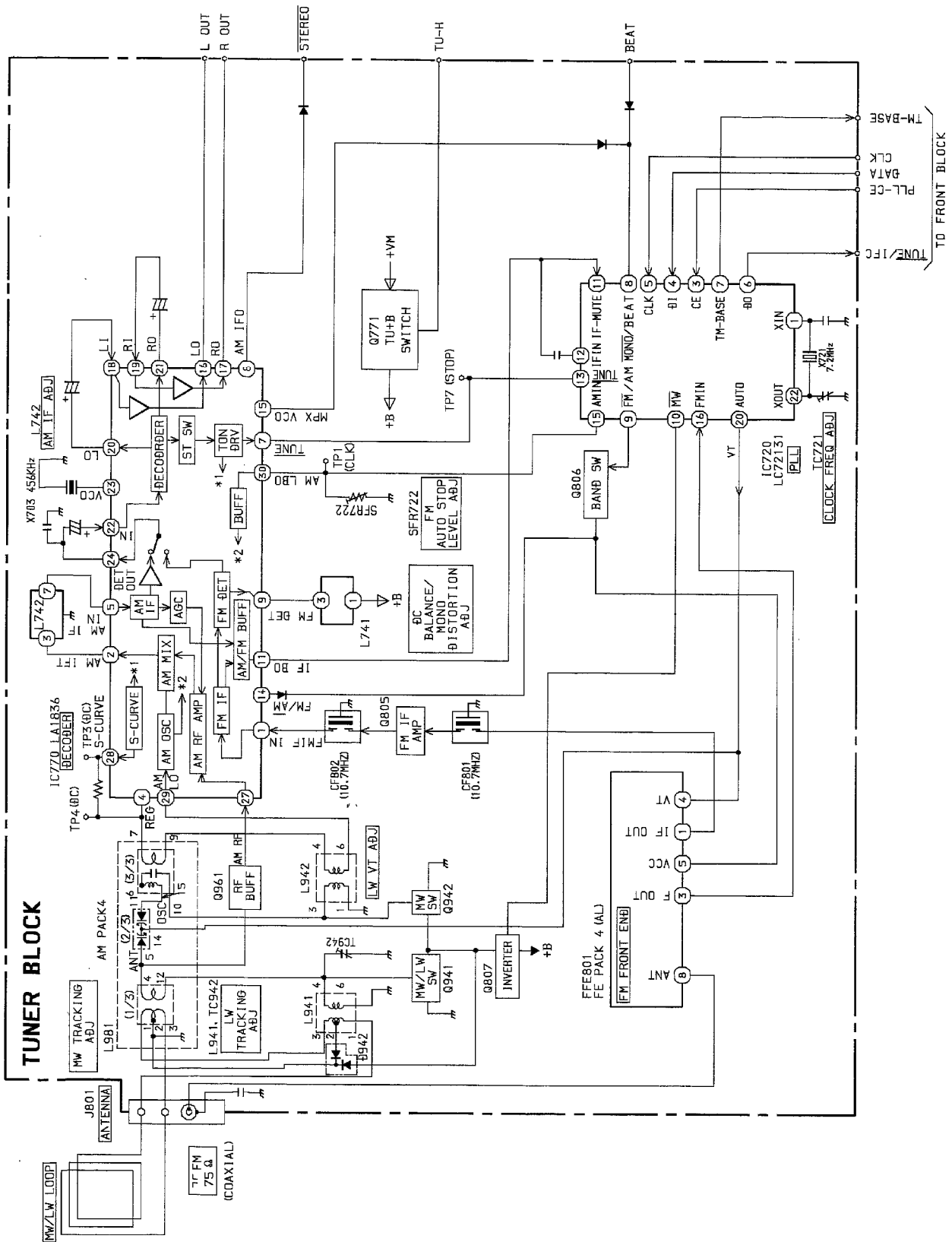

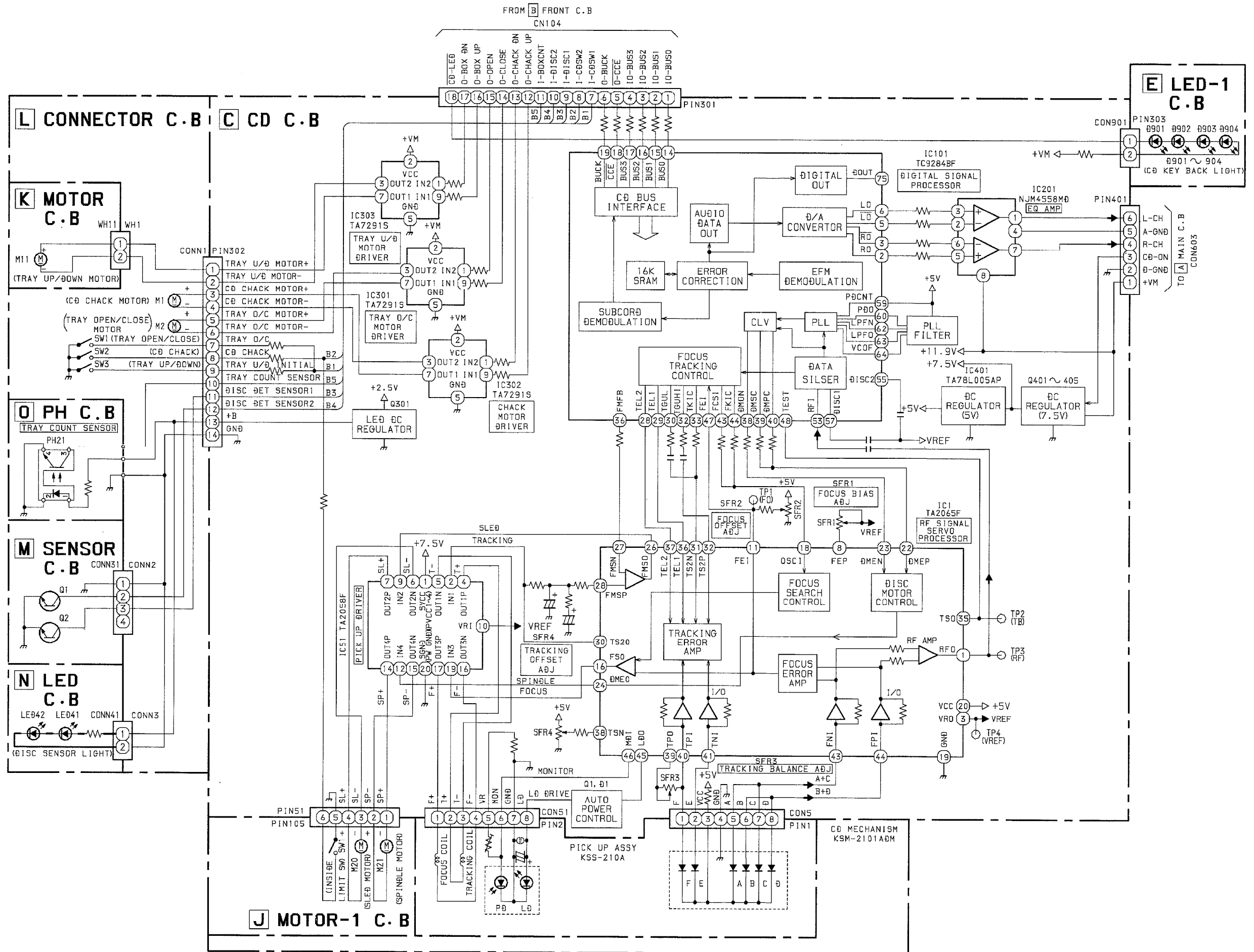

TRANSISTOR ILLUSTRATION



E C B

2SA1296
2SC1815
2SC3266
KTA1266
KTC3198



E C B

2SA1015
2SA952



E C B

DTA114YS
DTC144WS



E C B

2SA1318
2SC3331



B C E

2SB1370



E C

PT4850F

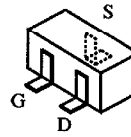

2SK543

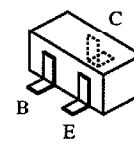

2SA1162
2SC2712
2SC2714
2SC3326

DTA143EK
DTA144EK
DTC143XK
DTC144EK
DTC144WK



D G S

2SK365

SCHEMATIC DIAGRAM - 1 (MAIN : HE, HK, HR, LH, U, G)

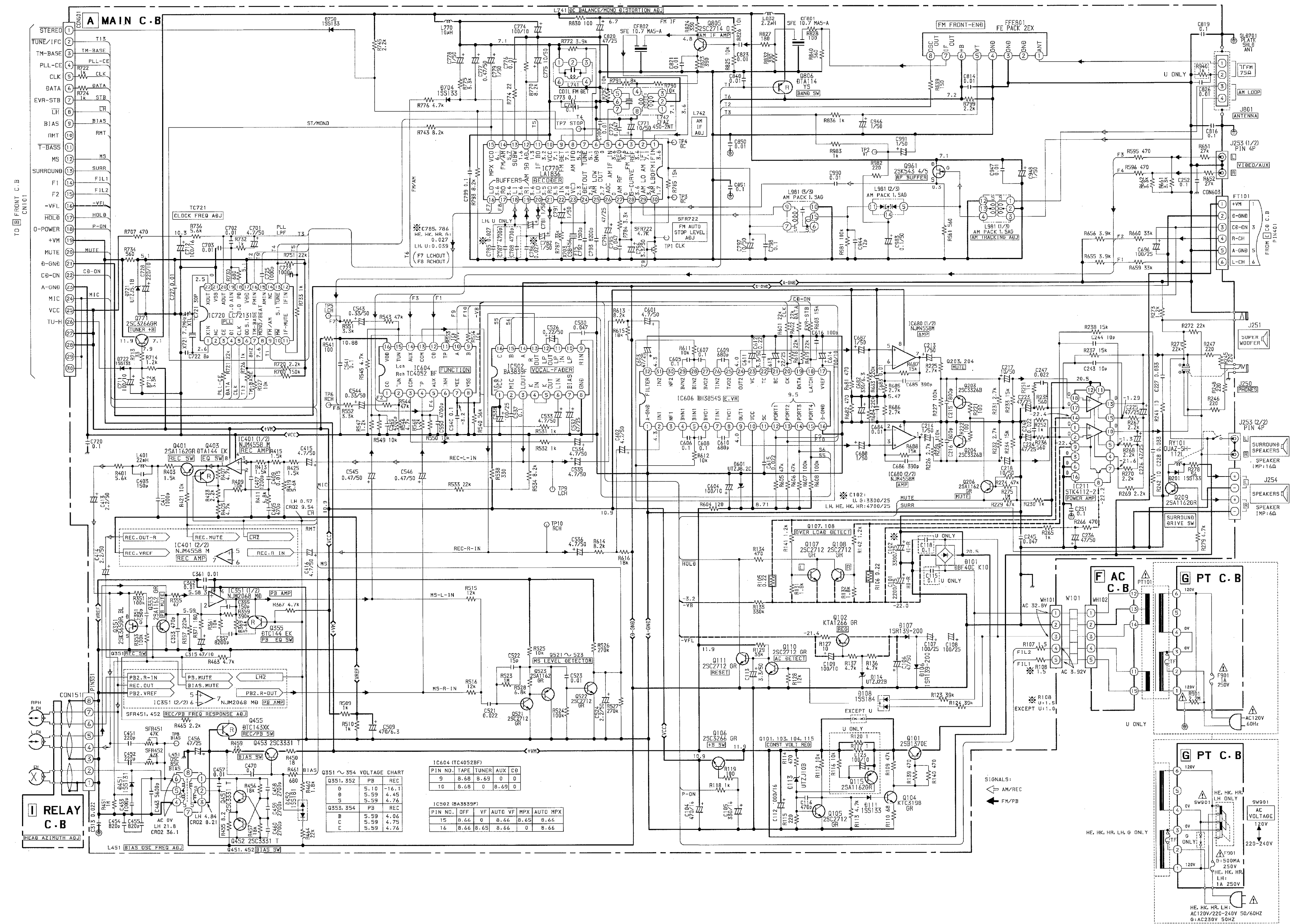

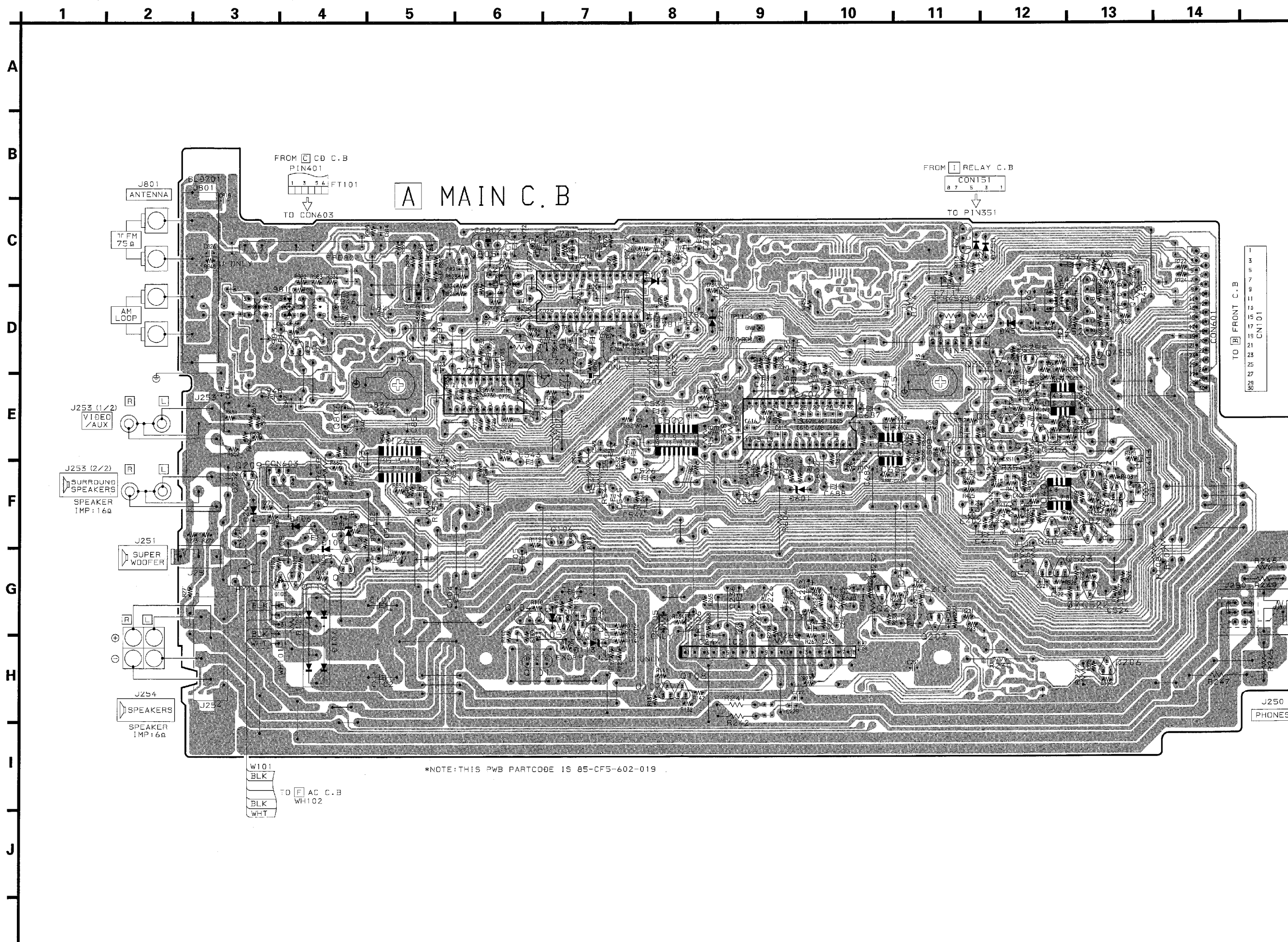

W101
BLK
TO AC C.B.
WH102
BLK
WHT

*NOTE: THIS PWB PART 00E IS 85-CF5-602-019

IC BLOCK DIAGRAM - 1

IC, BH3854S

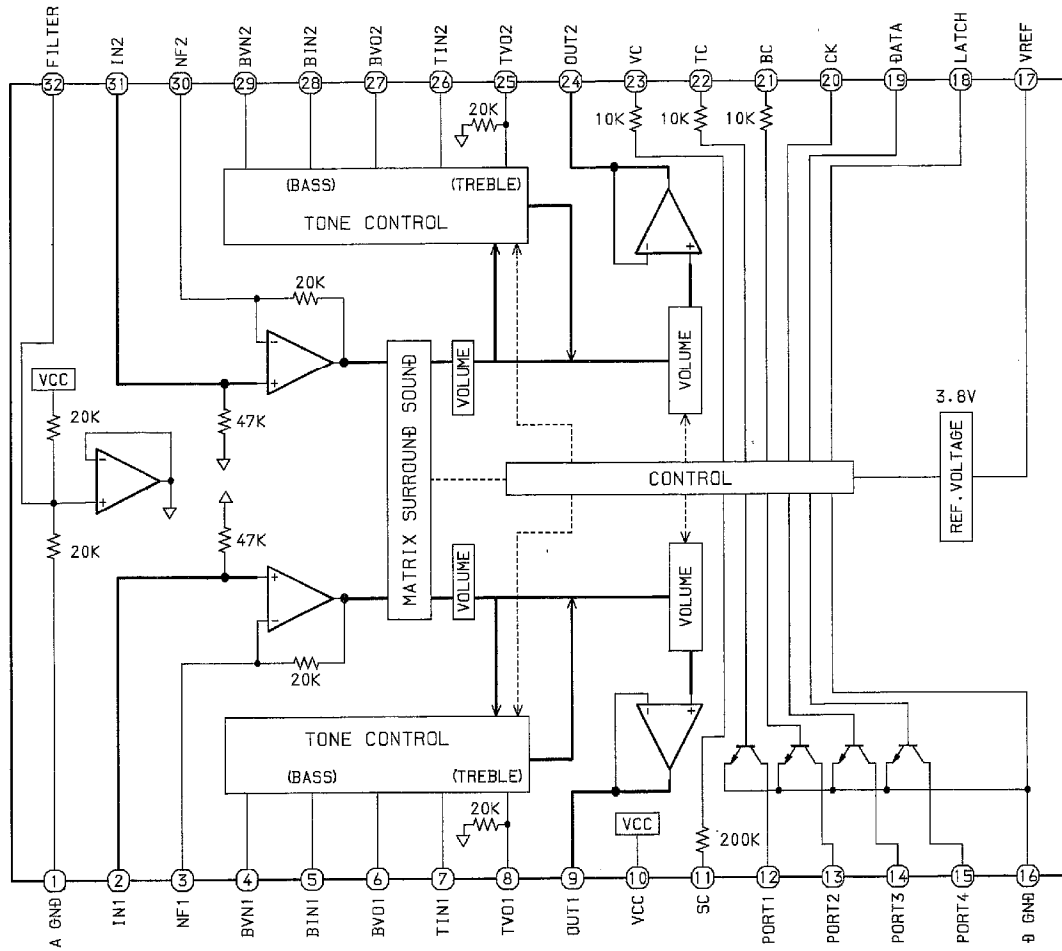

IC, BA3839F

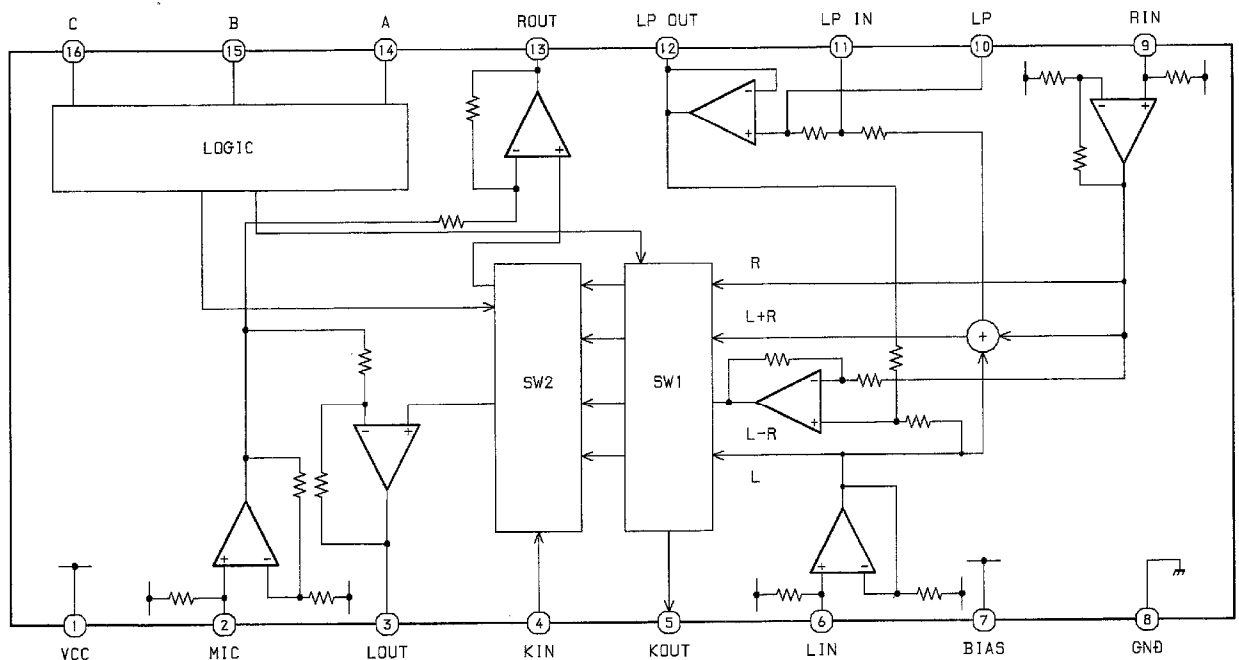

IC, LA1836

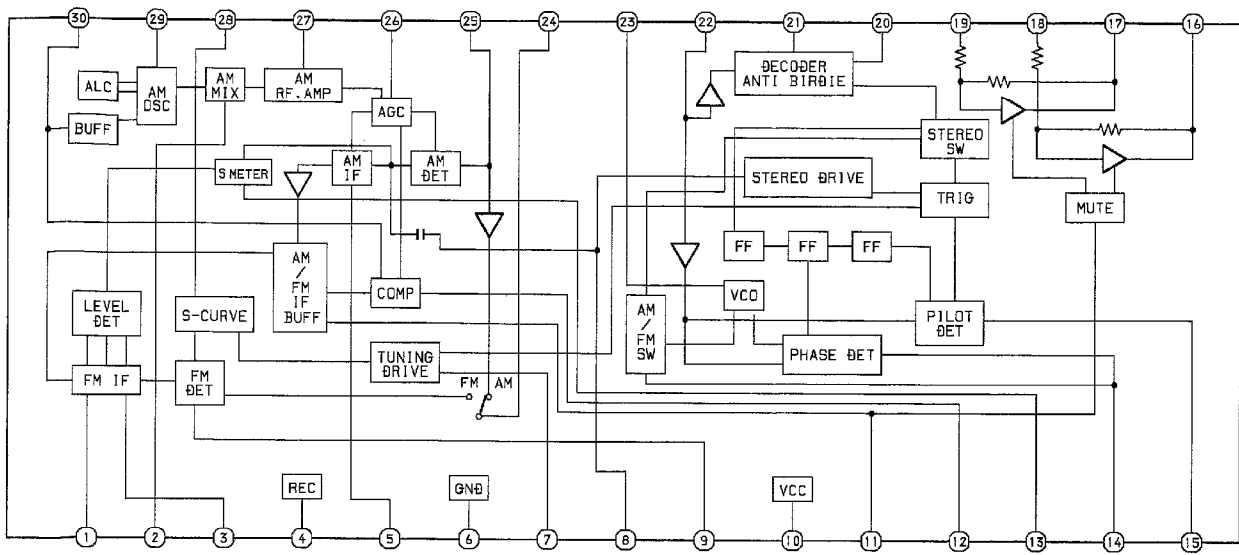

IC, TC4052BF

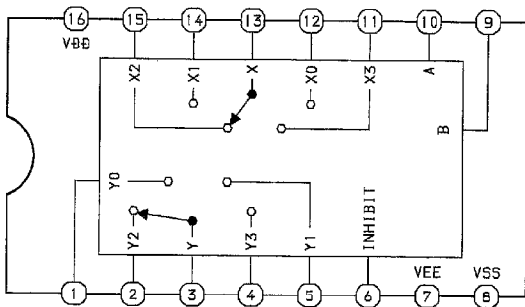

TRUTH TABLE

CONTROL INPUTS			ON SWITCH	
INHIBIT	B	A	Y0	X0
L	L	L	Y0	X0
L	L	H	Y1	X1
L	H	L	Y2	X2
L	H	H	Y3	X3
H	X	X	—	—

L: LOW LEVEL
 H: HIGH LEVEL
 X: IRRELEVANT

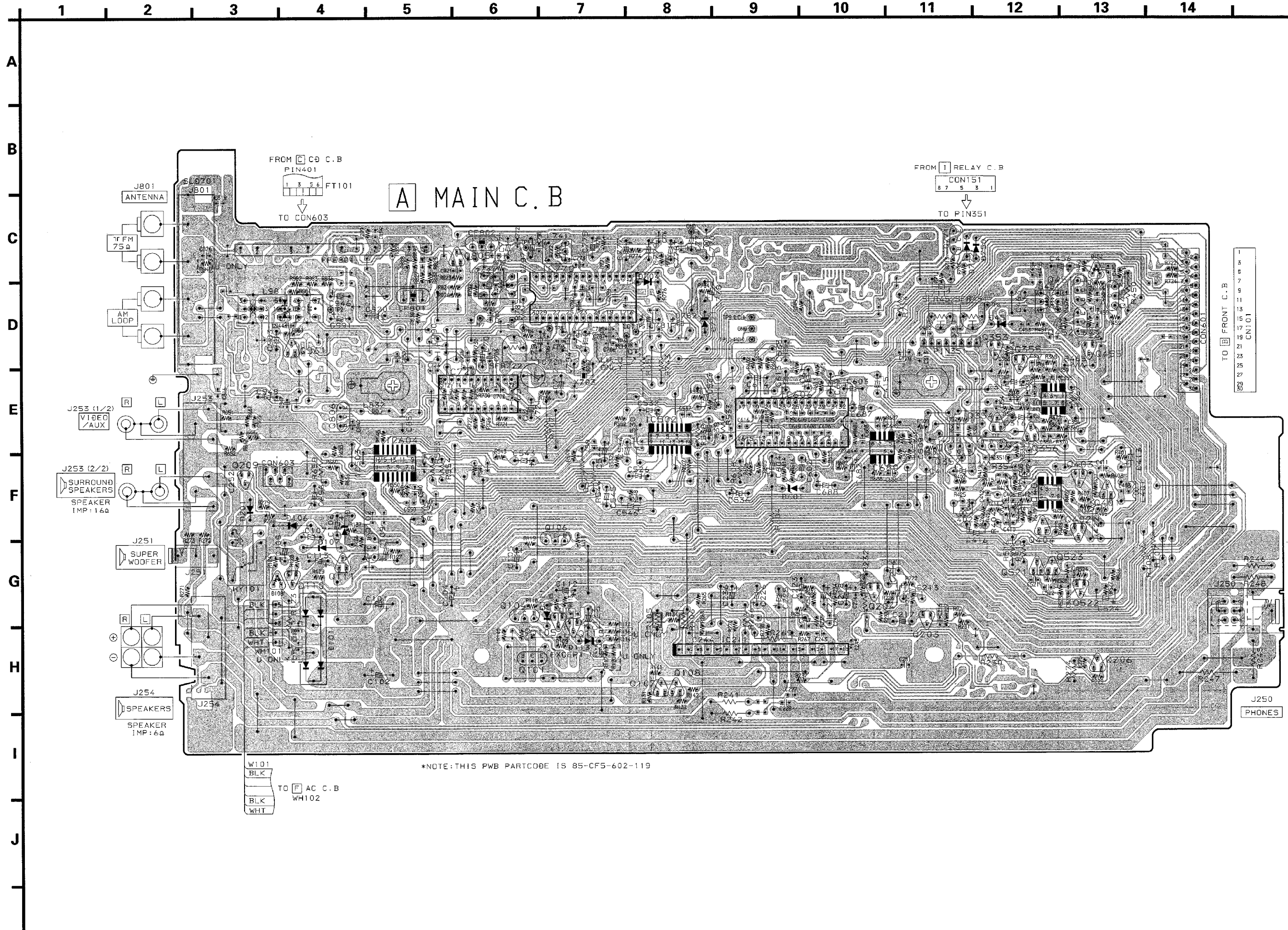

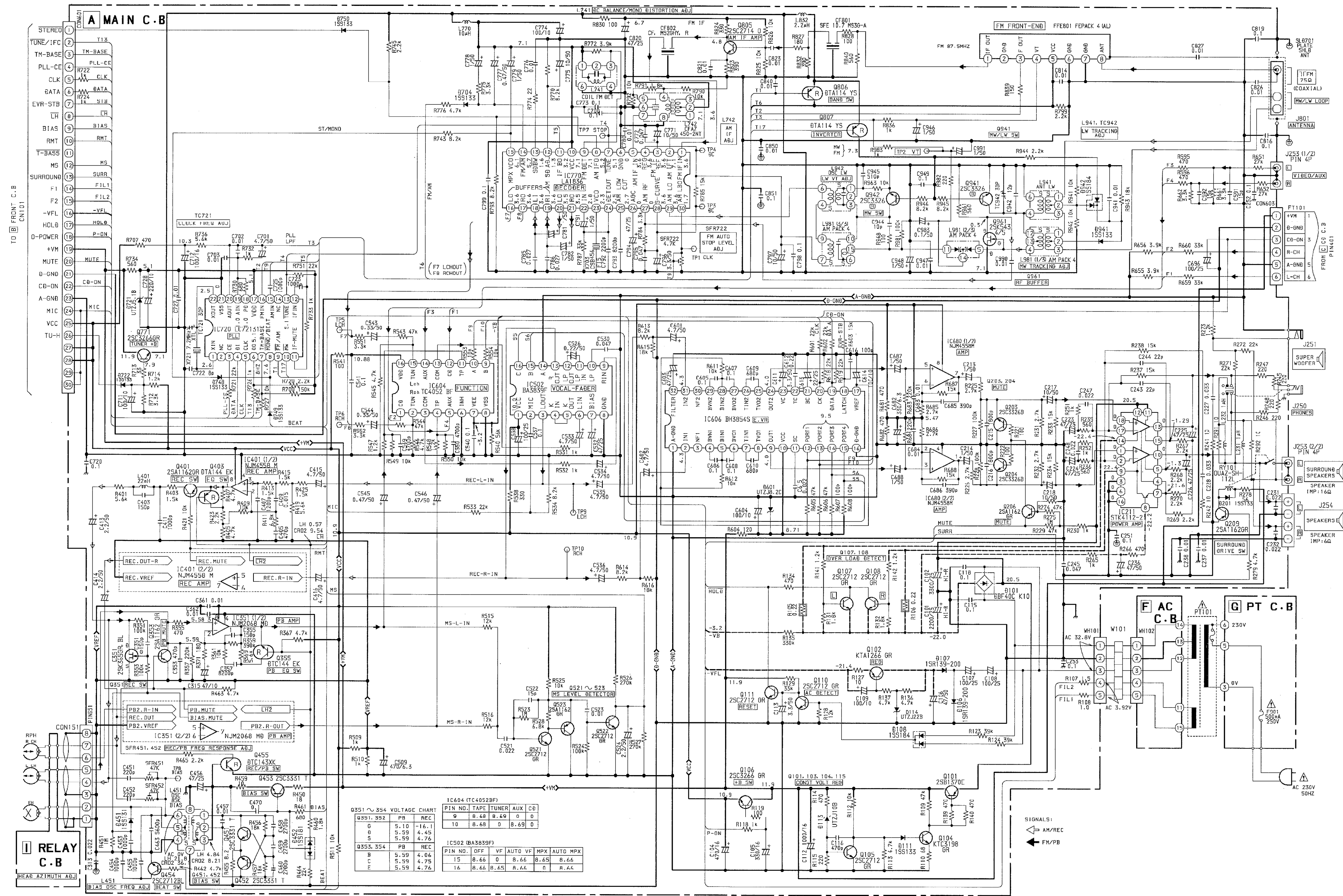

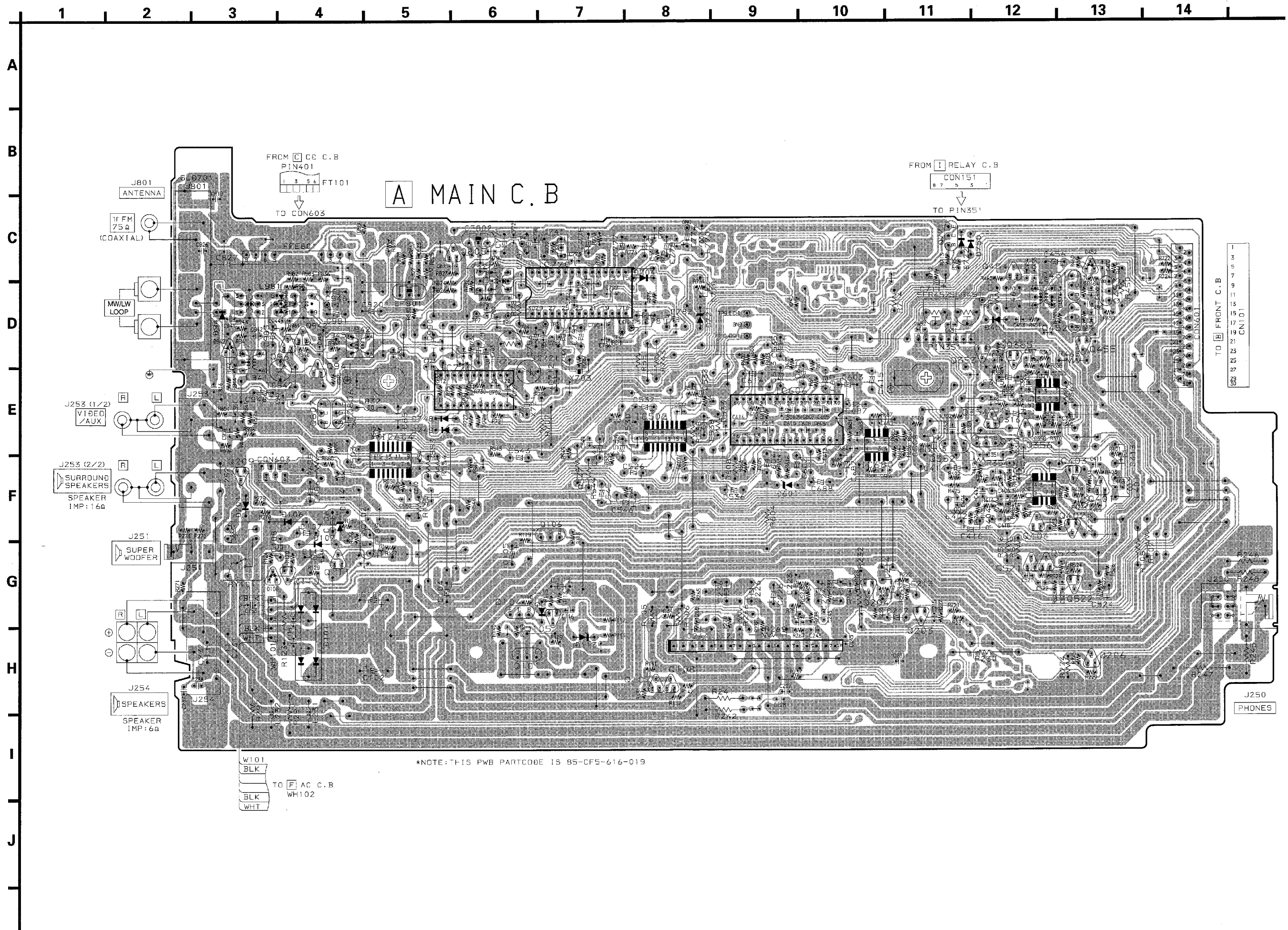

W101
BLK
TO AC C.B.
WH102
BLK
WHT

*NOTE: THIS PWB PARTCODE IS 95-CF5-616-019

IC BLOCK DIAGRAM - 2

IC, TC4094BF

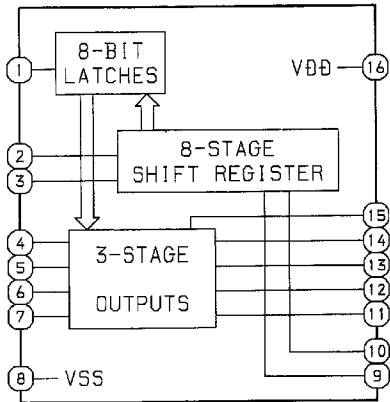

IC, TA7291S

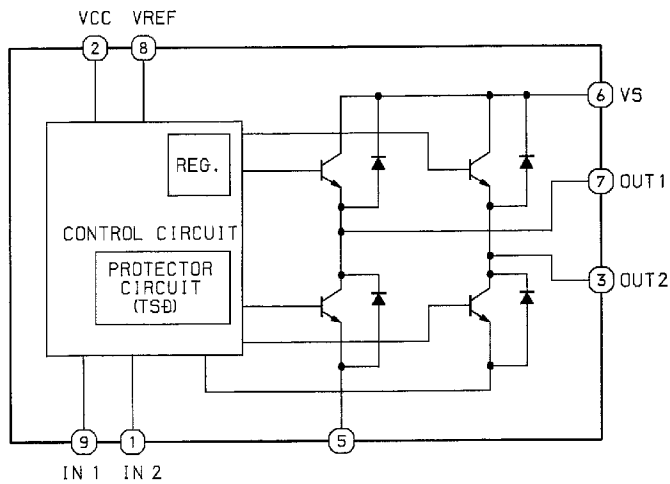

INPUT		OUTPUT		MODE
IN1	IN2	OUT1	OUT2	
0	0	∞	∞	STOP
1	0	H	L	CW
0	1	L	H	CCW
1	1	L	L	BRAKE

∞ : HI IMPEADENCE
NOTE : INPUT "H" ACTIVE

IC, TA2058F

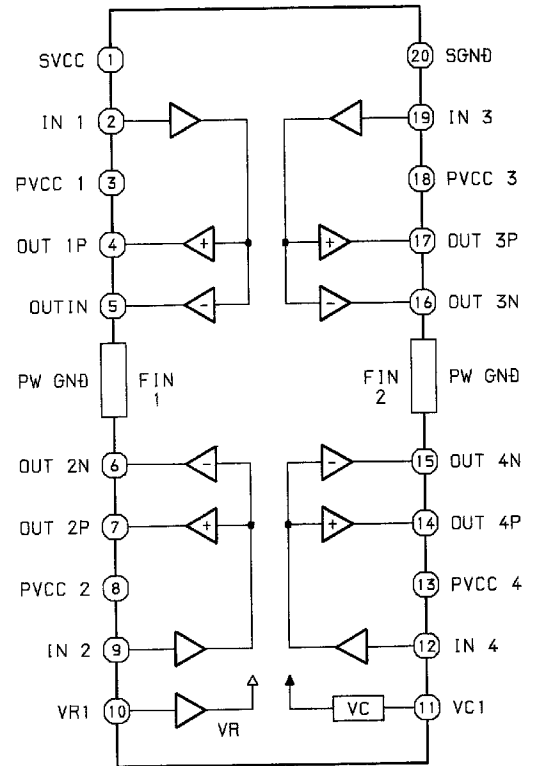

FL (8-BT-179GK) GRID ASSIGNMENT / ANODE CONNECTION

GRID ASSIGNMENT

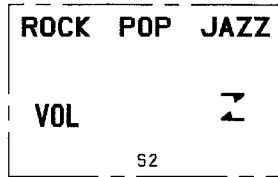
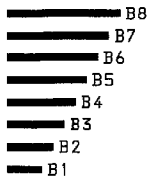
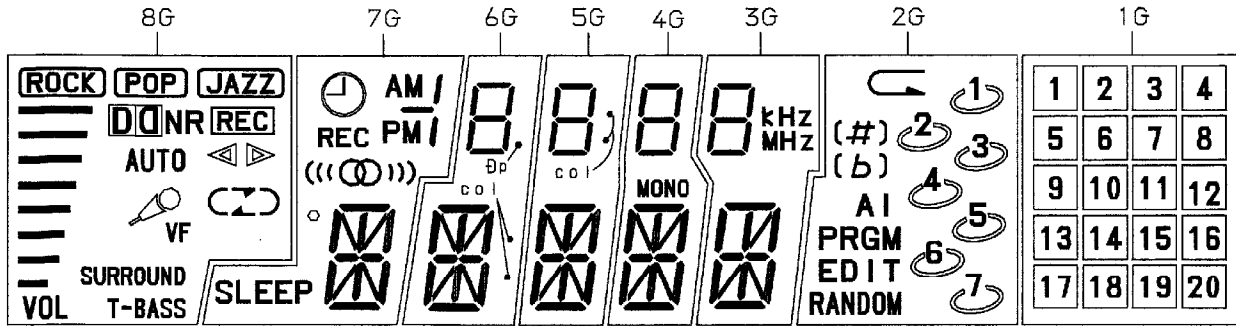

(8G)

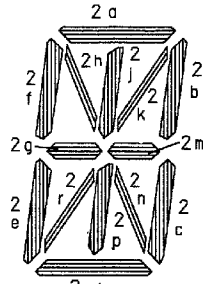

(7G ~ 3G)

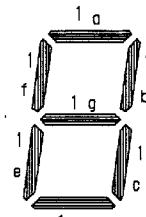

(6G ~ 3G)

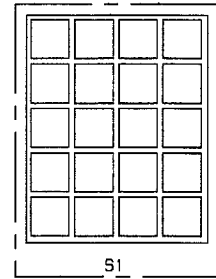

(1G)

ANODE CONNECTION

	8G	7G	6G	5G	4G	3G	2G	1G
P1	T-BASS	2d	2d	2d	2d	2d	RANDOM	20
P2	SURROUND	2j, 2p	2j, 2p	2j, 2p	2j, 2p	2j, 2p	EDIT	19
P3	VF	2n	2n	2n	2n	2n	PRGM	18
P4	(2r	2r	2r	2r	2r	AI	17
P5)	2c	2c	2c	2c	2c	(7)	16
P6	AUTO	2e	2e	2e	2e	2e	7	15
P7	▶	2m	2m	2m	2m	2m	(6)	14
P8	◀	2g	2g	2g	2g	2g	6	13
P9	DO NR	2f	2f	2f	2f	2f	(5)	12
P10	REC	2b	2b	2b	2b	2b	5	11
P11	(JAZZ)	2k	2k	2k	2k	2k	(4)	10
P12	(POP)	2h	2h	2h	2h	2h	4	9
P13	(ROCK)	2a	2a	2a	2a	2a	(3)	8
P14	B1	SLEEP	col	col [DOWN]	MONO	MHZ	3	7
P15	B2	o	θp	col [UP]	-	KHZ	(2)	6
P16	B3	AM	1a	1a	1a	1a	2	5
P17	B4	/	1b	1b	1b	1b	(1)	4
P18	B5	-	1f	1f	1f	1f	1	3
P19	B6	PM	1g	1g	1g	1g	(1)	2
P20	B7	⌚	1c	1c	1c	1c	(#)	1
P21	B8	REC	1e	1e	1e	1e	(b)	S1
P22	S2	((⊙))	1d	1d	1d	1d	#b	-

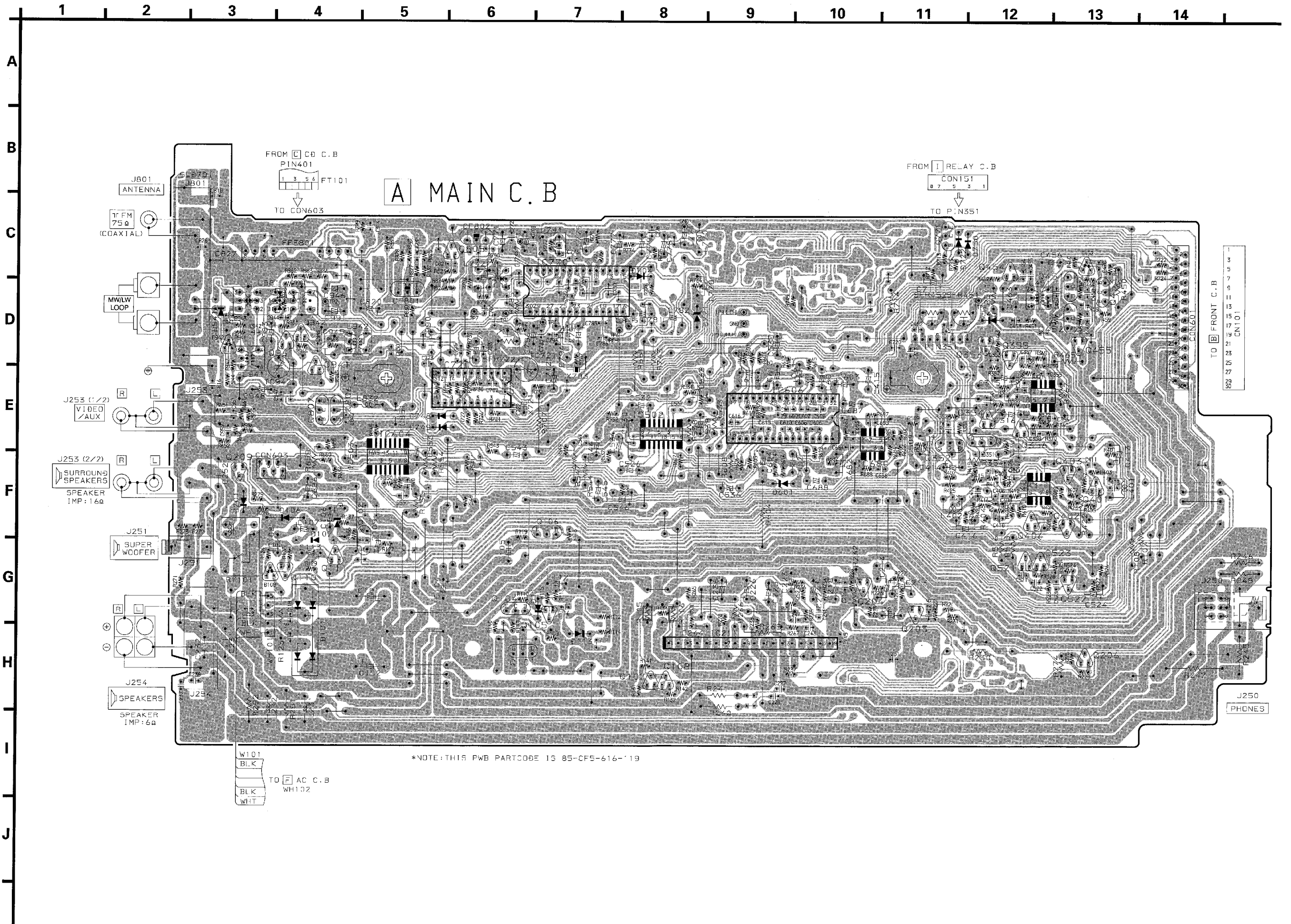

A MAIN C.B

*NOTE: THIS PWB PART CODE IS 85-CFS-616-19

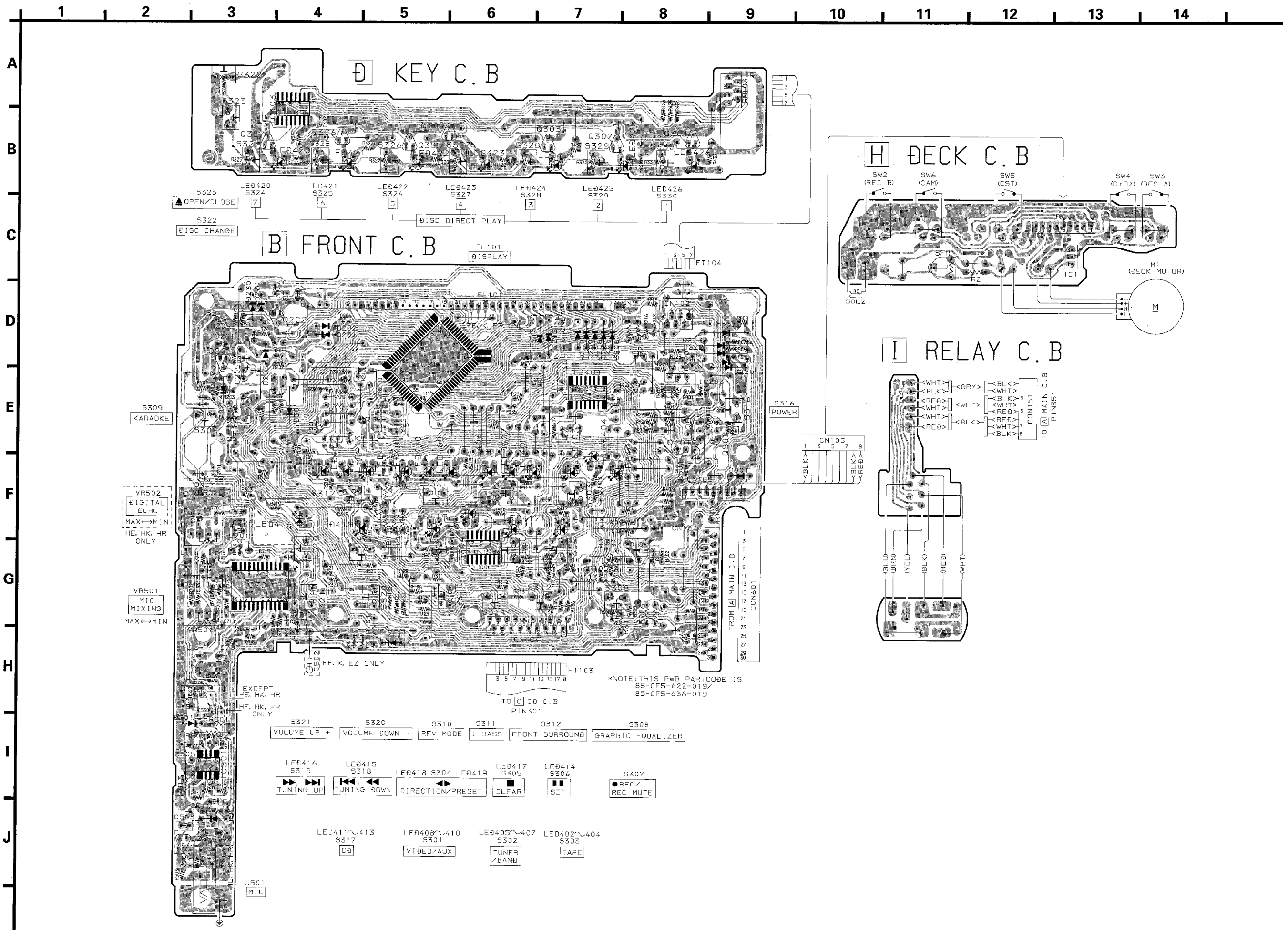

*NOTE: THIS PWB PARTCODE IS
85-CF5-622-019/
85-CF5-636-019

AD PORT INPUT LEVEL / WAVEFORM

① I-CD SW2

CD SWITCH (LIMIT SW, CHACK SW) AD INPUT

LIMIT SW : Switch on at the most internal circle.

CHACK SW : Switch on when chacking.

Voltage must be within when below mode.

VOLTAGE	AD		LIMIT-SW	CHACK-SW
	Hex	Dec		
5.60	FF	255	OFF	OFF
4.95	E 1	225	ON	OFF
3.83	AE	174	OFF	ON
3.08	8C	140	ON	ON
0.00	00	0		

② I-CD SW1

CD SWITCH (OPEN SW, BOX SW) AD INPUT

OPEN SW : Switch off when open or close.

BOX SW : Switch on when the box is the most below position.

Voltage must be within when below mode.

VOLTAGE	AD		LIMIT-SW	CHACK-SW
	Hex	Dec		
5.60	FF	255	OFF	OFF
4.95	E 1	225	ON	OFF
3.83	AE	174	OFF	ON
3.08	8C	140	ON	ON
0.00	00	0		

③ BOX COUNT SENSOR

Tray 1 open / close

CLOSE

VOLT / DIV : 5V

TIME / DIV : 200mS

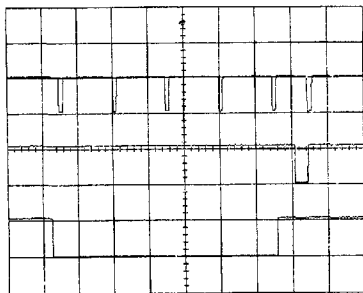

1-BOX CNT

O-BOX UP

O-BOX DN

OPEN

VOLT / DIV : 5V

TIME / DIV : 200mS

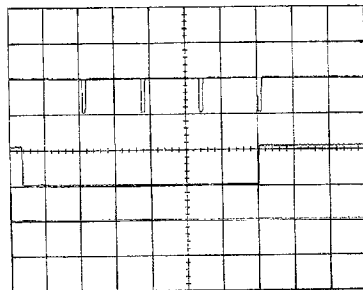

1-BOX CNT

O-BOX UP

O-BOX DN

④ DISC 1

⑤ DISC 2

Signal pattern : No disc, 8 cm, 12 cm

Tray can not close when signal pattern is different.

No disc

VOLT / DIV : 2V

TIME / DIV : 100mS

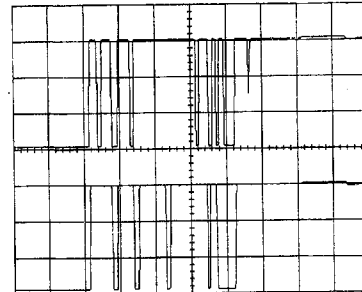

⑤
DISC 2

④
DISC 1

8 cm

VOLT / DIV : 2V

TIME / DIV : 100mS

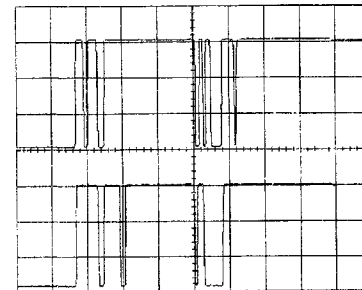

⑤
DISC 2

④
DISC 1

12 cm

VOLT / DIV : 2V

TIME / DIV : 100mS

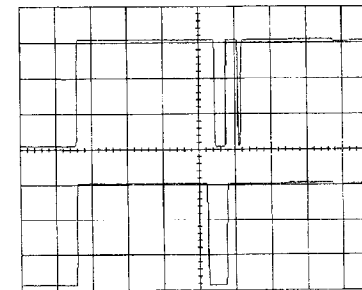

⑤
DISC 2

④
DISC 1

- ⑥ PDO
- ⑦ LPFO
- Disc turn speed

High VOLT / DIV : 2V
TIME / DIV : 1μS

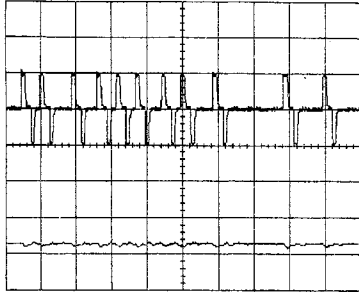

⑥
PDO

⑦
LPFO

- ⑧ DMPC
- ⑨ DMFC
- ⑩ DMEO
- Spindle motor rotation speed

High ⑧ ⑨ VOLT / DIV : 2V
TIME / DIV : 5mS
⑩ VOLT / DIV : 1V
TIME / DIV : 5mS

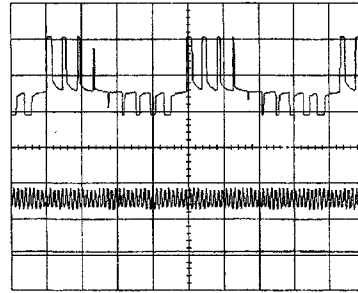

⑧
DMPC

⑨
DMFC

⑩
DMEO

Slow

VOLT / DIV : 2V
TIME / DIV : 1μS

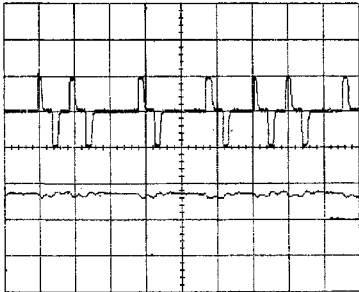

⑥
PDO

⑦
LPFO

Slow ⑧ ⑨ VOLT / DIV : 2V
TIME / DIV : 5mS
⑩ VOLT / DIV : 1V
TIME / DIV : 5mS

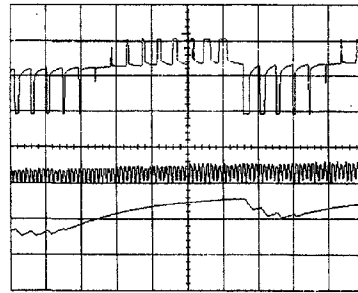

⑧
DMPC

⑨
DMFC

⑩
DMEO

Normal

VOLT / DIV : 2V
TIME / DIV : 1μS

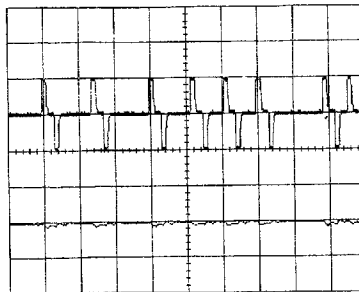

⑥
PDO

⑦
LPFO

Normal ⑧ ⑨ VOLT / DIV : 2V
TIME / DIV : 5mS
⑩ VOLT : 1V
TIME / DIV : 5mS

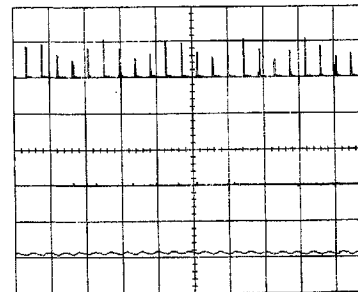

⑧
DMPC
VREF LEVEL

⑨
DMFC
VREF LEVEL

⑩
DMEO
VREF LEVEL

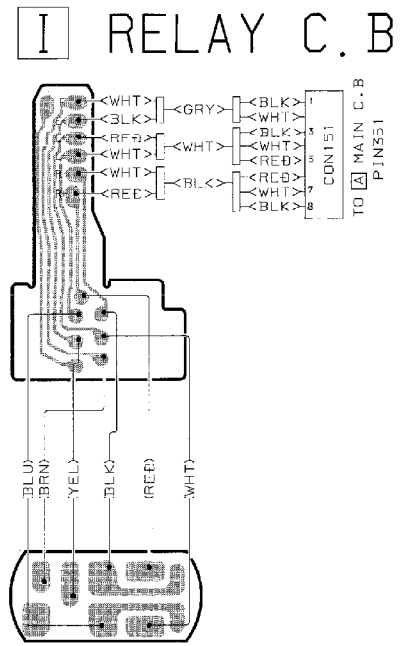
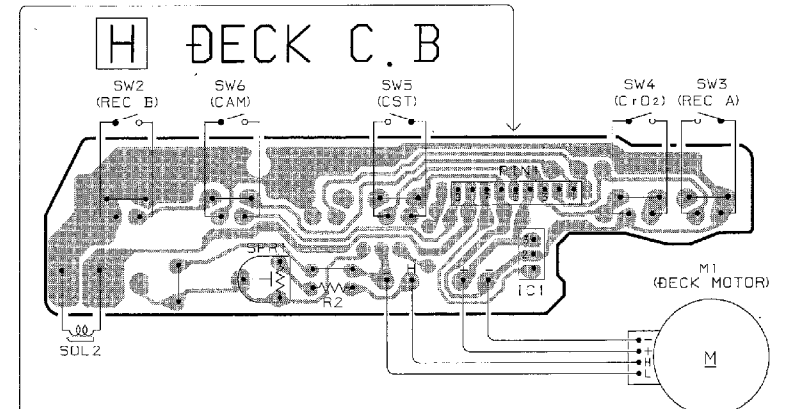
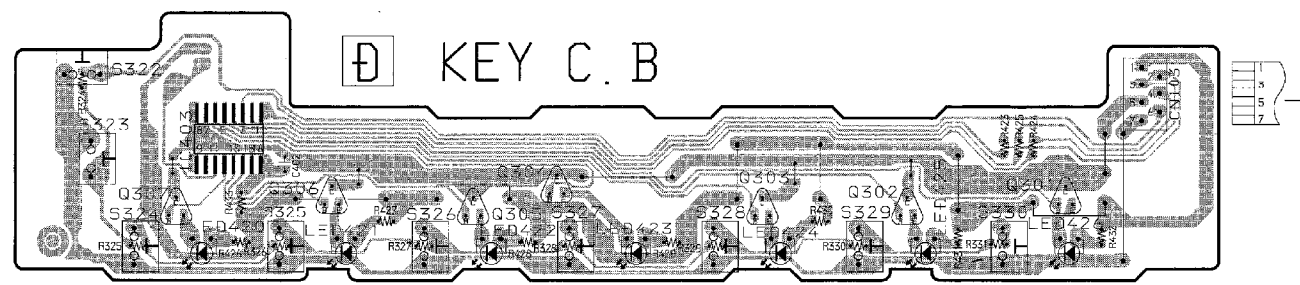
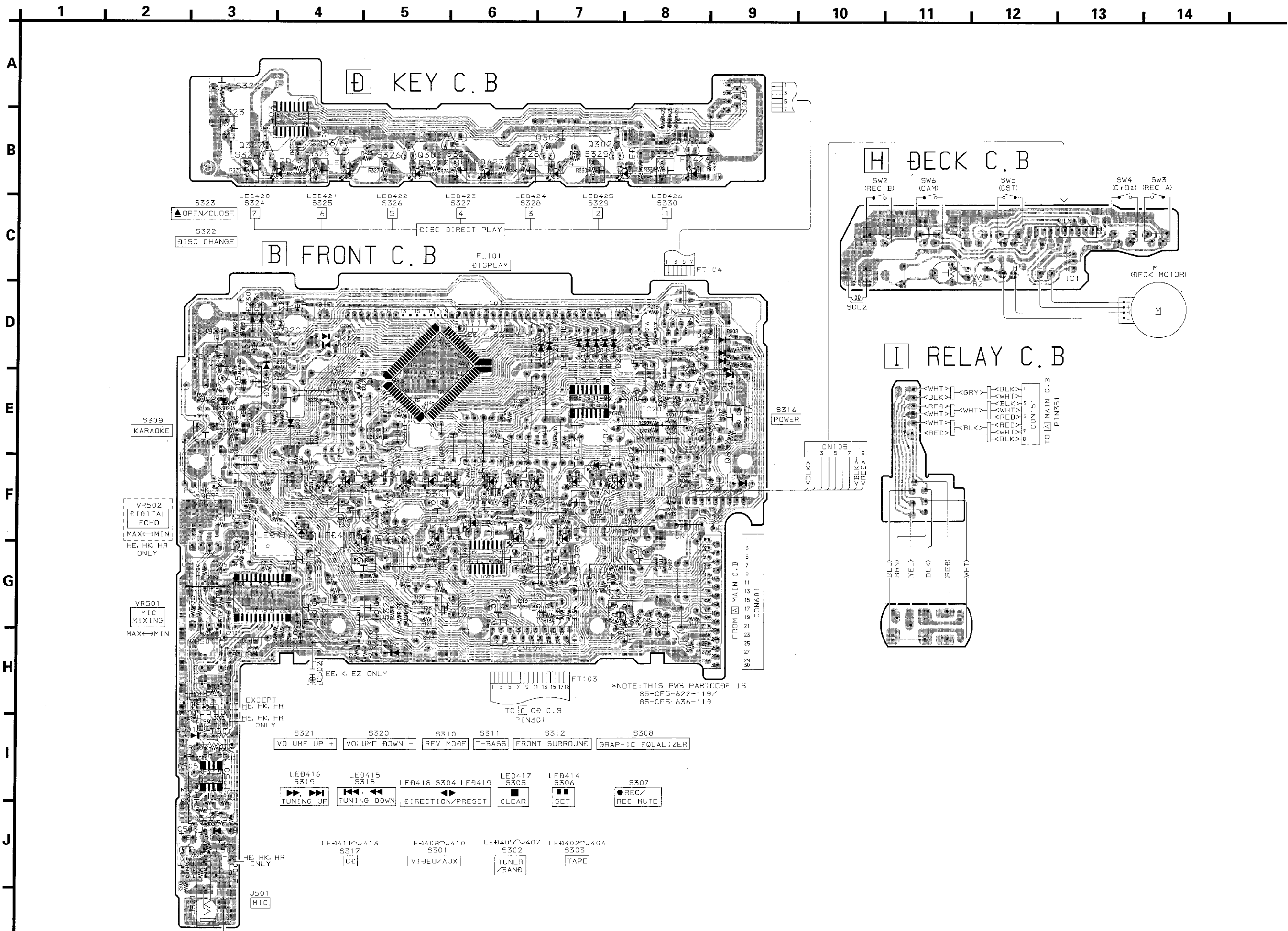

*NOTE: THIS PCB PART NO. IS
85-CF5-622-19/
85-CF5-636-19

SCHEMATIC DIAGRAM - 4 (CD)

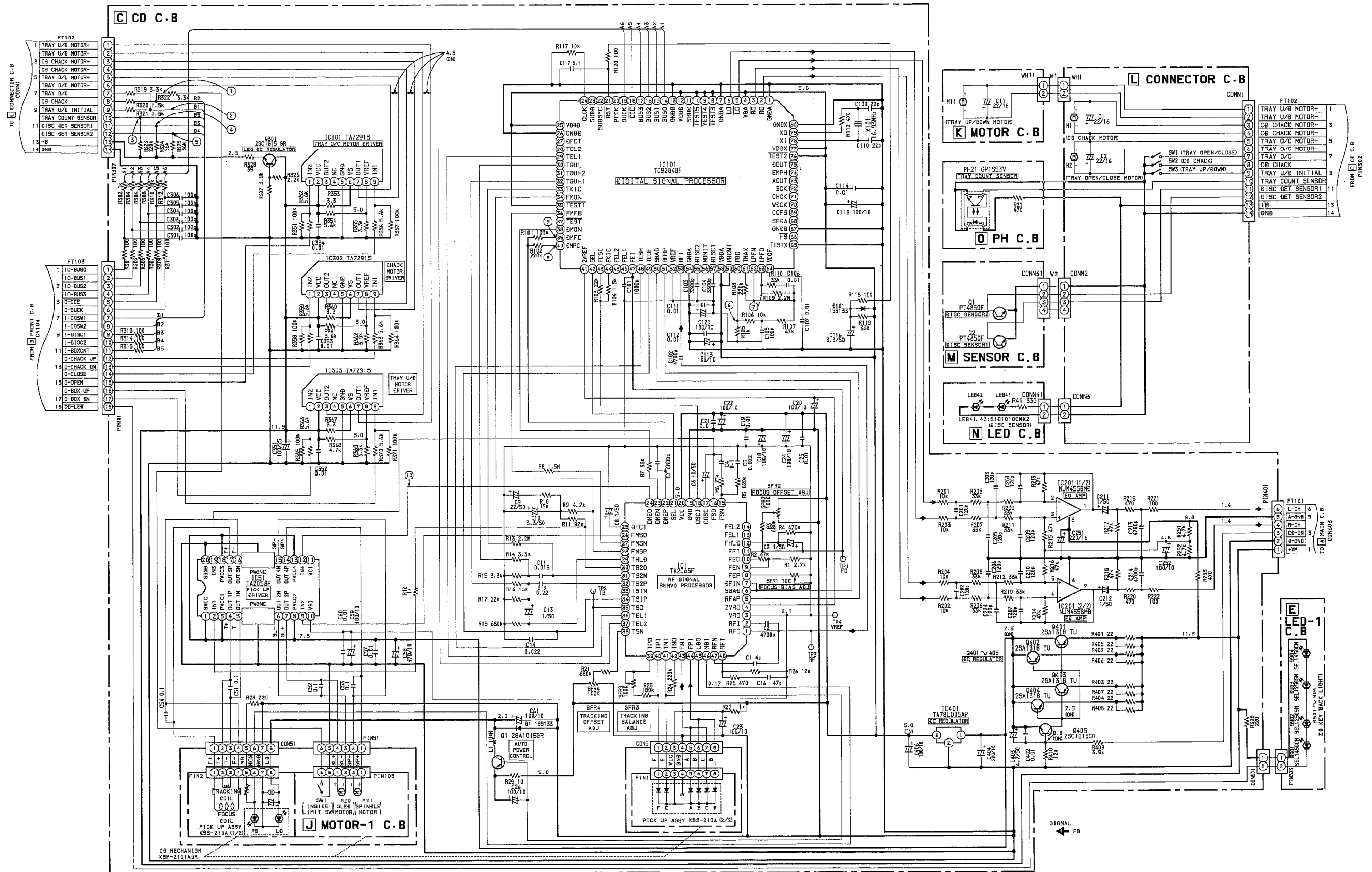

1 2 3 4 5 6 7 8 9 10 11 12 13 14

A
B
C
D
E
F
G
H
I
J

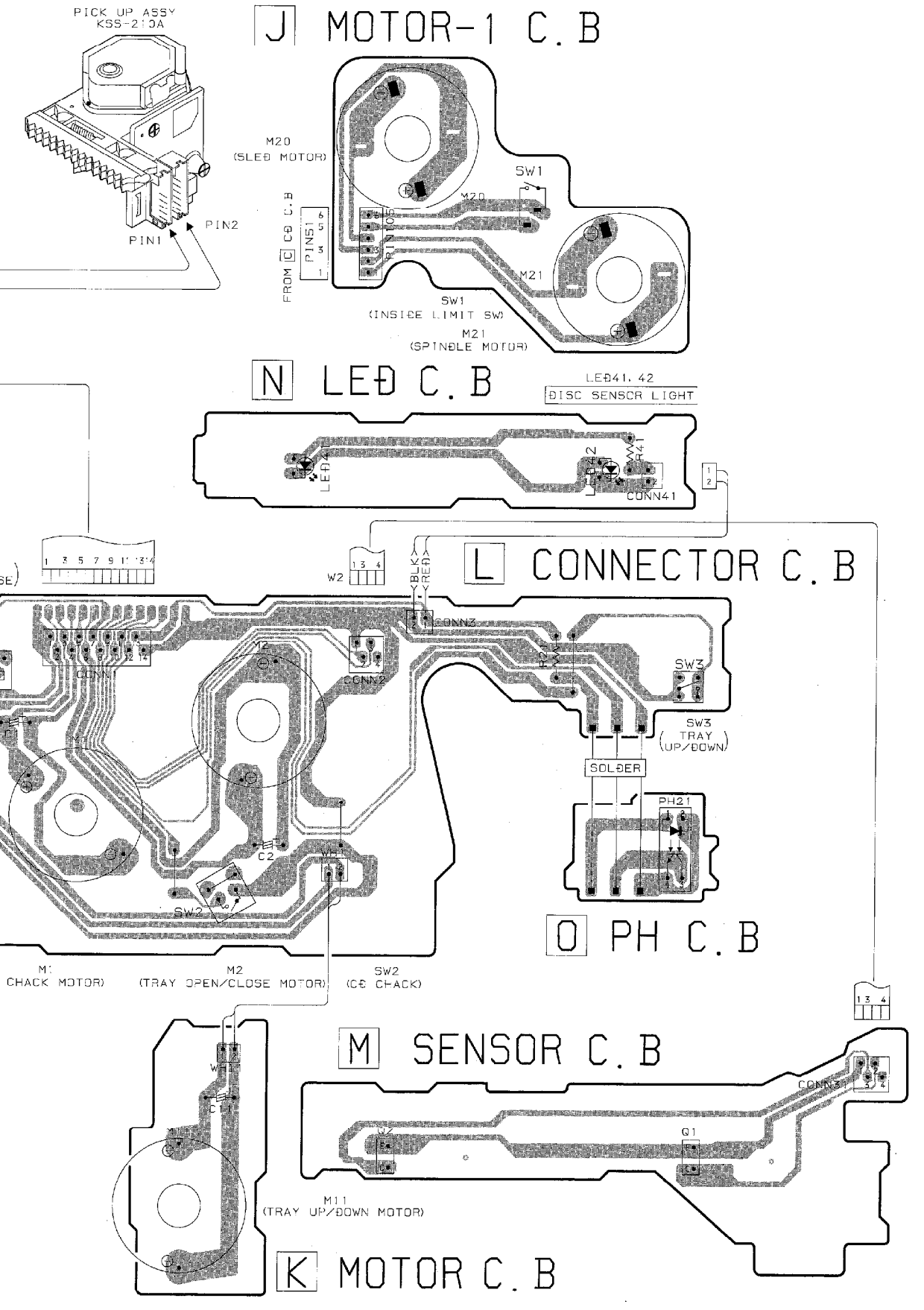
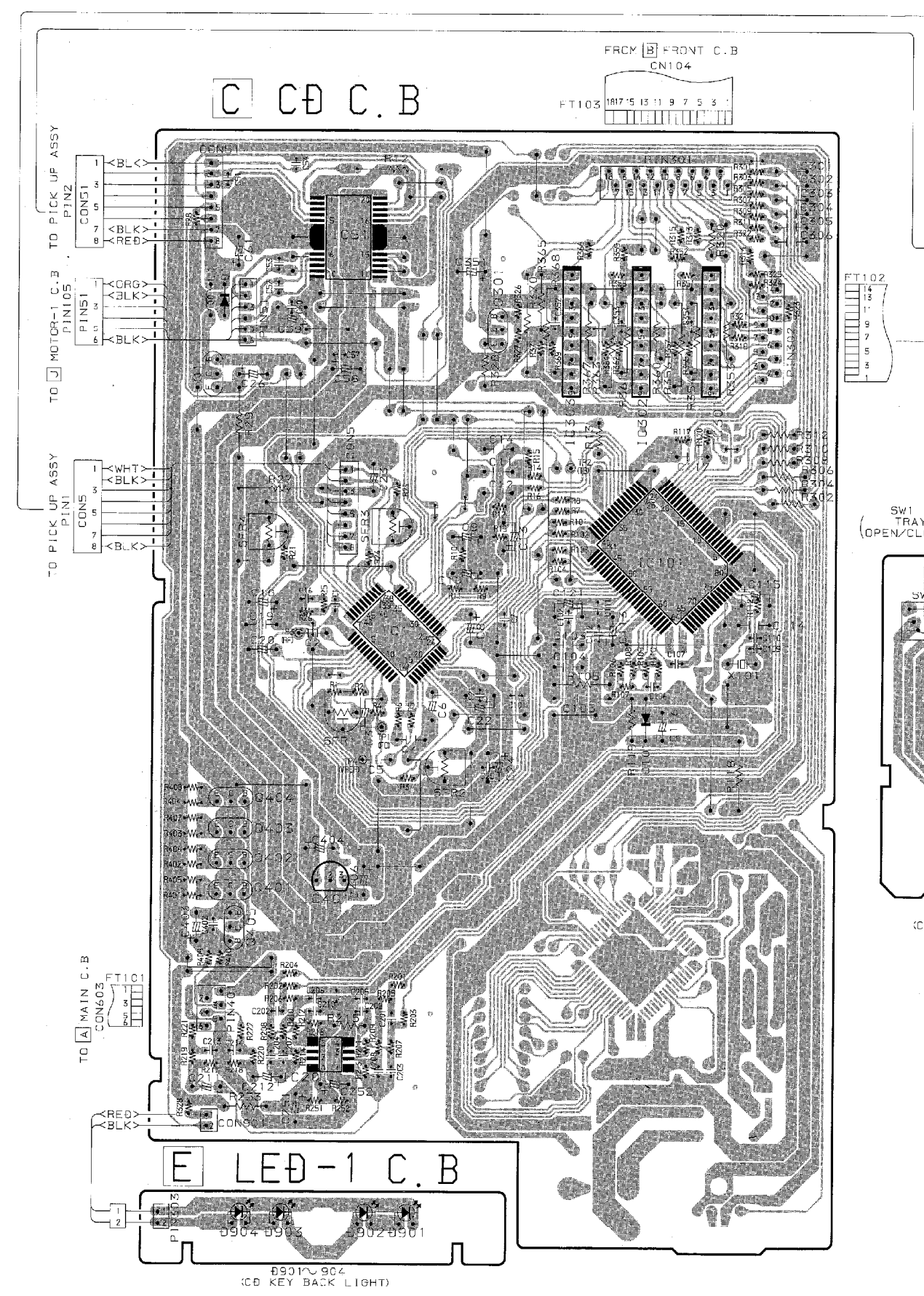

WIRING - 8 (PT)

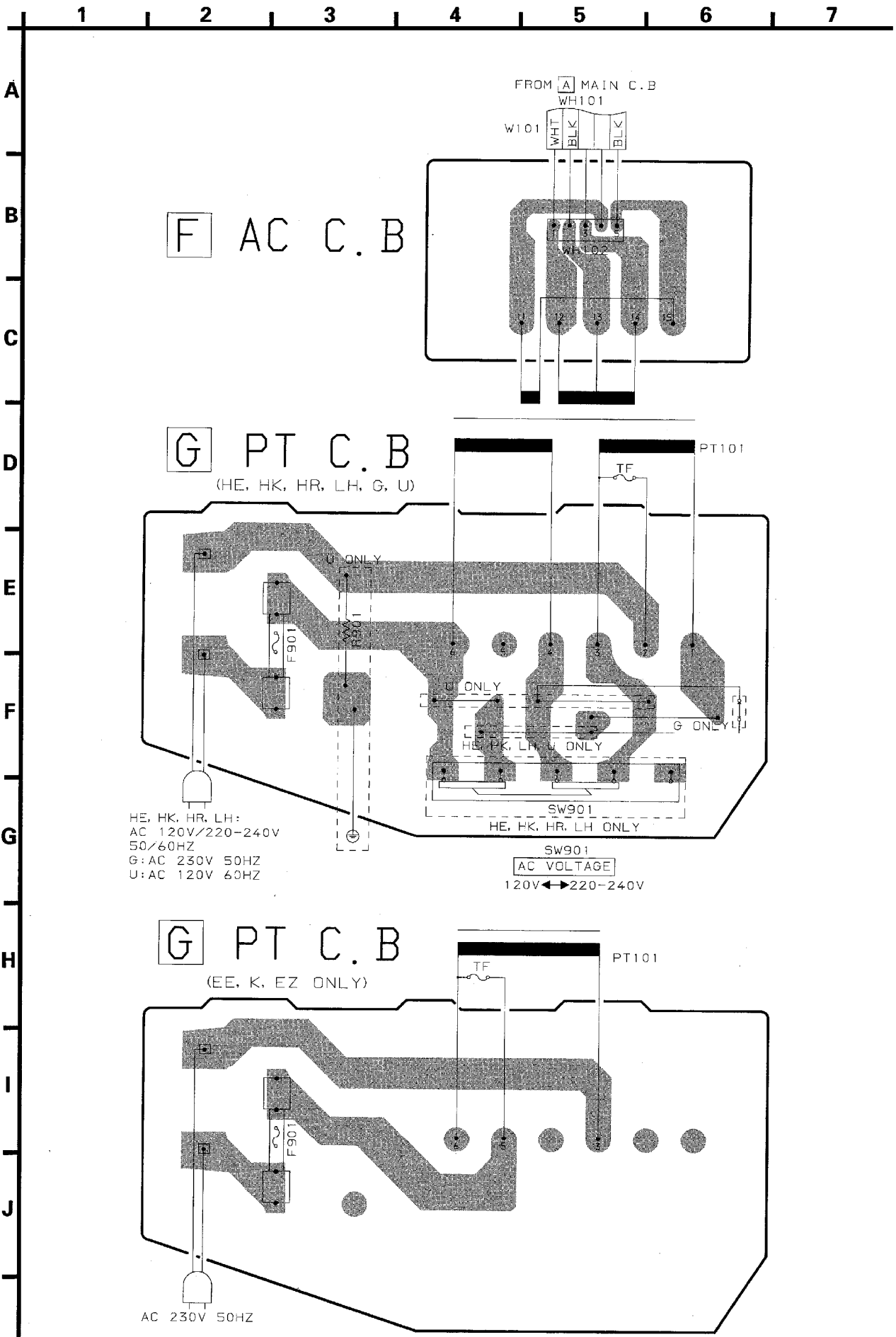

ADJUSTMENT - 1 <TUNER / DECK>

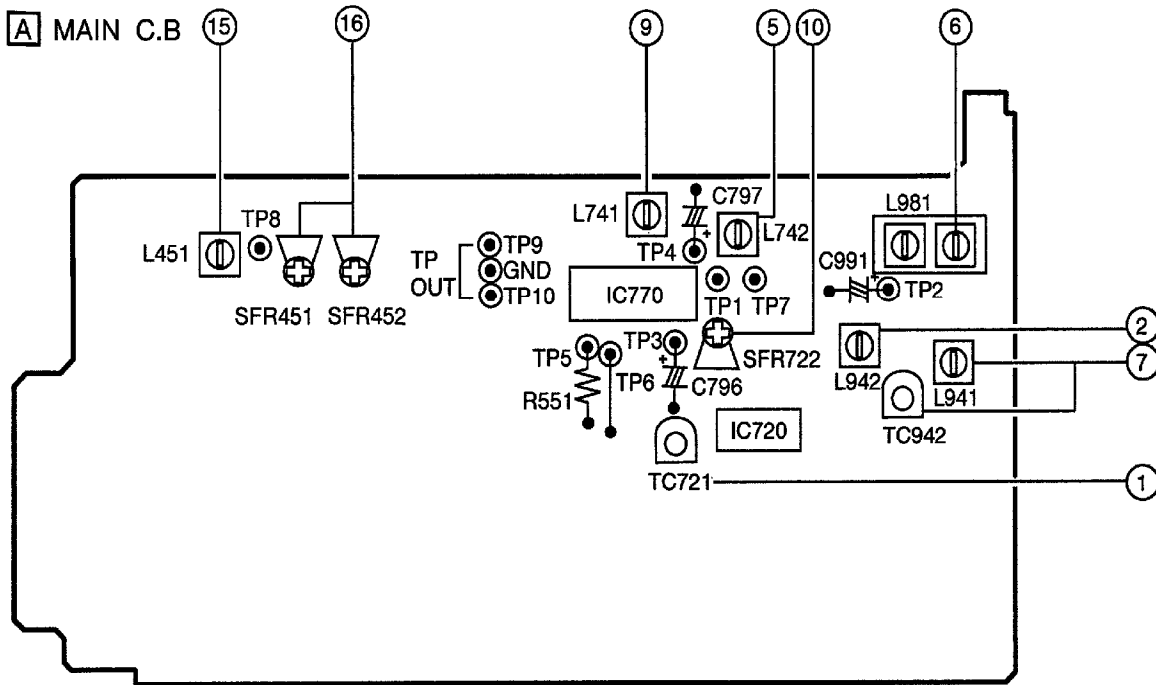

H DECK C.B

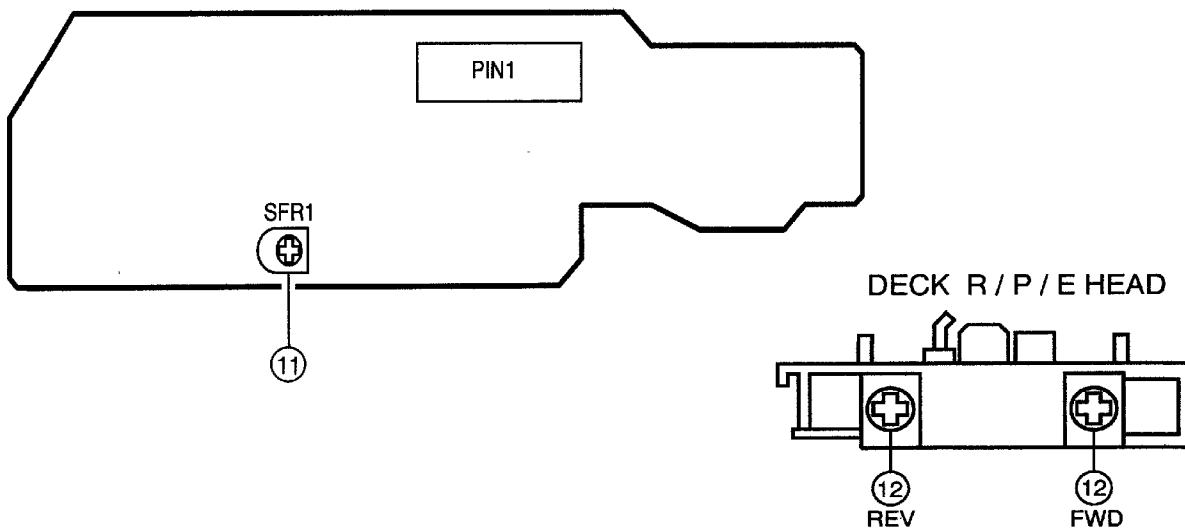

< TUNER SECTION >

1. Clock Frequency Adjustment
 - Settings : • Test point : TP1 (CLK IC770 pin30)
 - Adjustment location : TC721
 - Method : Set to MW 1602kHz (HE, HK, HR, G, EE, K, EZ), 1710kHz (LH, U) and adjust TC721 so that the test point becomes 2052kHz \pm 0.01kHz (HE, HK, HR, G, EE, K, EZ), 2160kHz \pm 0.01kHz (LH, U).
2. LW VT Adjustment <EE, K, EZ>
 - Settings : • Test point : TP2 (VT)
 - Adjustment location : L942
 - Method : Set to LW 144kHz and adjust L942 so that the test point becomes 1.5V \pm 0.05V.
3. FM VT Check
 - Settings : • Test point : TP2 (VT)
 - Method : Set to FM 108MHz and check that the test point is 7.0V \pm 1.0V.
4. MW VT Check
 - Settings : • Test point : TP2 (VT)
 - Method : Set to MW 1602kHz (HE, HK, HR, G, EE, K, EZ), 1710kHz (LH, U) and check that the test point is 6.5V \pm 1.0V (HE, HK, HR, G, EE, K, EZ), 7.0V \pm 1.0V (LH, U).
5. AM IF Adjustment
 - Settings : • Test point : TP5 (Lch), TP6 (Rch)
 - L742 450kHz

6. MW Tracking Adjustment
 Settings : • Test point : TP5 (Lch), TP6 (Rch)
 • Adjustment location : L981
 Method : Set to MW 999kHz (HE, HK, HR, G, EE, K, EZ), 1000kHz (LH, U) and adjust L981 so that the test point becomes maximum.
7. LW Tracking Adjustment <EE, K, EZ>
 Settings : • Test point : TP5 (Lch), TP6 (Rch)
 • Adjustment location :
 L941 144kHz
 TC942 290kHz
 Method : Set up TC942 to center before adjustment. The level at 144kHz is adjusted to MAX by L941. Then the level at 290kHz is adjusted to MAX by TC942.
8. FM Sensitivity Check
 Settings : • Test point : TP5 (Lch), TP6 (Rch)
 Method : Set to FM 87.5MHz and 108MHz, and check that the test point is $2\text{dB} \pm 6\text{dB}$ (HE, HK, HR, LH, U, G), $6\text{dB} \pm 6\text{dB}$ (EE, K, EZ)
9. DC Balance / Mono Distortion Adjustment
 Settings : • Test point : TP3, TP4 (DC Balance)
 TP5, TP6 (Mono Distortion)
 • Adjustment location : L741
 • Input level : 54dB
 Method : Set to FM 98.0MHz and adjust L741 so that the voltage between TP3 and TP4 becomes $0\text{V} \pm 0.04\text{V}$.
 Next, check that the distortion is less than 1.3%.
10. FM Auto Stop Level Adjustment
 Settings : • Test point : TP7
 • Adjustment location : SFR722
 • Input level : 16dB
 Method : Set to FM 98.0MHz and adjust voltage low (about 0.01V) by SFR722. After that voltage high (about 7.0V) out by 2dB down.
- < DECK SECTION >
11. Tape Speed Check
 Settings : • Test tape : TTA-100
 • Test point : TP OUT
 • Adjustment location : SFR1
 Method : Play back the test tape and check for $3000\text{Hz} \pm 5\text{Hz}$ (FWD) and FWD PLAY speed $\pm 45\text{Hz}$ (REV).
12. Head Azimuth Adjustment
 Settings : • Test tape : TTA-300
 • Test point : TP OUT
 • Adjustment location : Head azimuth adjustment screw
 Method : Play back the 10kHz signal of the test tape and adjust screw so that the output becomes maximum.
 Next, perform on each FWD PLAY and REV PLAY mode.
13. PB Sensitivity Check
 Settings : • Test tape : TTA-200
 • Test point : TP OUT
 Method : Play back the 400Hz signal of the test tape and check that the test point is within $300\text{mV} \pm 3\text{dB}$.
14. PB Frequency Response Check
 Settings : • Test tape : TTA-300
 • Test point : TP OUT
 Method : Play back the 315Hz and 10kHz signals of the test tape and check that the 10Hz signal with respect to that of the 315Hz signal is within 2dB.
15. Bias OSC Frequency Adjustment
 Settings : • Test tape : TTA-601
 • Test point : TP8
 • Adjustment location : L451
 Method : Set to the REC mode. Adjust L451 so that the frequency at the test point becomes 84kHz to 92kHz.
16. REC/PB Frequency Response Adjustment
 Settings : • Test tape : TTA-602
 • Test point : TP OUT
 • Input signal : 1kHz / 10kHz
 (VIDEO/AUX IN)
 • Adjustment location : SFR451 (Lch)
 SFR452 (Rch)
 Method : Apply a 1kHz signal and REC mode. Then adjust OSC attenuator so that the output level at the TP OUT becomes 210mV. Record and play back the 1kHz and 10kHz signals and adjust SFRs so that the output level of the 10kHz signal becomes $0\text{dB} \pm 0.5\text{dB}$ with respect to that of the 1kHz.
17. REC/PB Sensitivity Check
 Settings : • Test tape : TTA-602
 • Test point : TP OUT
 • Input signal : 1kHz (VIDEO/AUX IN)
 Method : Apply a 1kHz signal and REC mode. Then adjust OSC attenuator so that the output level at the TP OUT becomes 21mV. Record and play back the 1kHz signal and check that the output level is $21\text{mV} \pm 3\text{dB}$.

ADJUSTMENT – 2 <CD>

CD C.B

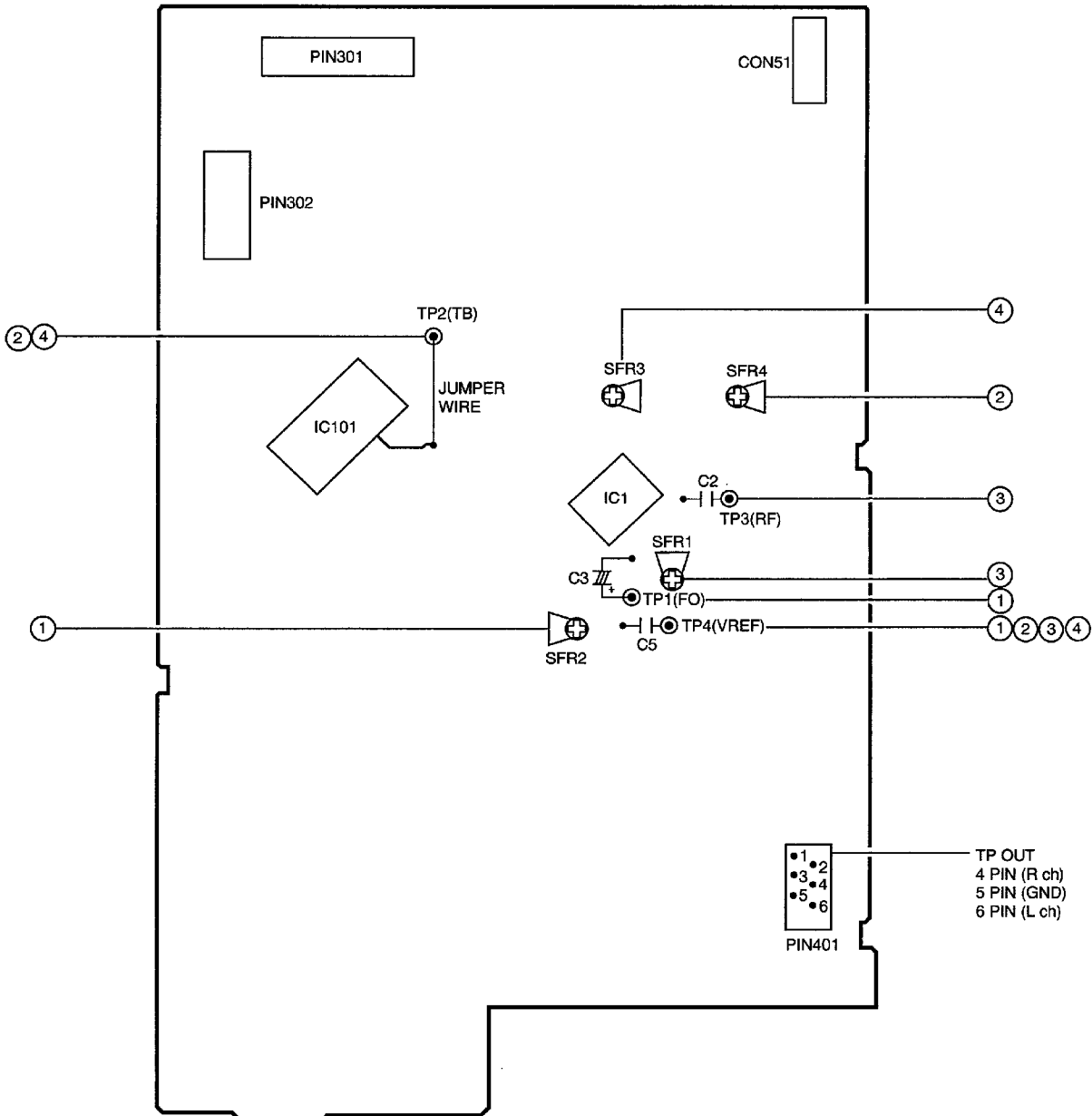

Note :
Connect a probe (10:1) of the oscilloscope or the frequency counter to a test point.

1. Focus Offset Adjustment

- 1) Short the pin 1 and pin 3 of PIN401 with wire.
- 2) Connect an oscilloscope to the test points TP1 (FO) and TP4 (VREF).
- 3) Turn on the power switch.
- 4) Adjust SFR2 so that the offset voltage becomes $0mV \pm 5mV$.
- 5) After the adjustment is completed, remove the short wire from PIN401.

2. Tracking Offset Adjustment

- 1) Short the pin 1 and pin 3 of PIN401 with wire.
- 2) Connect an oscilloscope to the test points TP2 (TB) and TP4 (VREF).
- 3) Turn on the power switch.
- 4) Adjust SFR4 so that the offset voltage becomes $0mV \pm 5mV$.
- 5) After the adjustment is completed, remove the short wire from PIN401.

3. Focus Bias Adjustment

Make the focus bias adjustment when replacing and repairing the optical block.

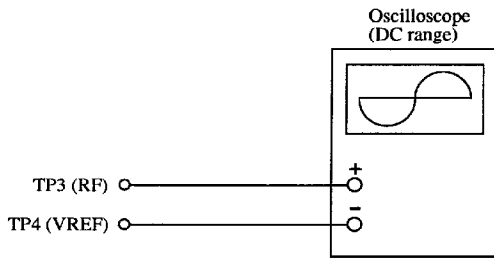

- 1) Connect an oscilloscope to the test points TP3 (RF) and TP4 (VREF).
- 2) Turn on the power switch.
- 3) Insert test disc TCD-782 (YEDS-18) and play back the second composition.
- 4) Adjust SFR1 so that RF signal of the test point TP3 (RF) is MAX and CLEARREST.

RF signal waveform

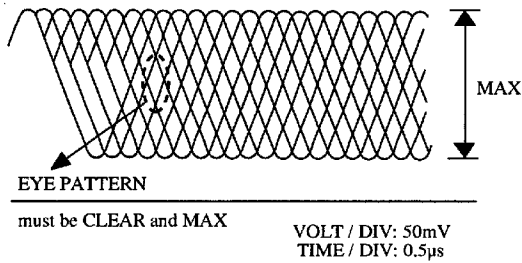

Note:

The current of the laser signal can be checked with the voltages on both sides of R23 (10Ω). The difference for the specified value shown on the level must be within ± 6.0mA.

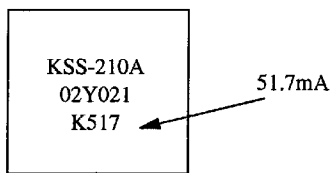

$$\text{Laser current } I_{op} = \frac{\text{Voltage across R23}}{10\Omega}$$

4. Tracking Balance Adjustment

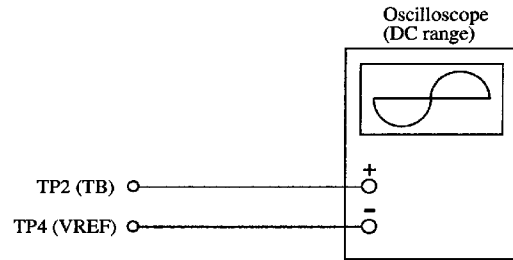

- 1) Connect an oscilloscope to the test points TP2 (TB) and TP4 (VREF).
- 2) Turn on the power switch.
- 3) Insert test disc TCD-782 (YEDS-18) and press the PLAY button.
- 4) Adjust SFR3 so that the waveform on the oscilloscope is vertically symmetrical as shown in the figure below.
- 5) After the adjustment is completed, remove the connected lead wires from the terminals.

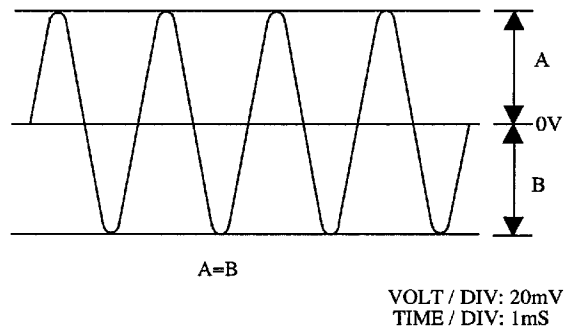

PRACTICAL SERVICE FIGURE

<TUNER SECTION>

<FM SECTION>

IHF Sensitivity : (THD 3%)	6dB ± 6dB [at 87.5MHz (HE, HK, HR, G, LH, U)] 12dB ± 6dB [at 87.5MHz (EE, K, EZ)] 4dB ± 6dB [at 98.0 / 108.0MHz (HE, HK, HR, G, LH, U)] 11dB ± 6dB [at 98.0 / 108.0MHz (EE, K, EZ)]
S/N 50dB Quieting sensitivity :	30dB ± 5dB [at 87.5 / 98.0 / 108.0MHz (HE, HK, HR, G, LH, U)] 36dB ± 5dB [at 87.5 / 98.0 / 108.0MHz (EE, K, EZ)]
Signal to noise ratio :	More than 64dB [at 98.0MHz (HE, HK, HR, G, LH, U)] More than 59dB [at 98.0MHz (EE, K, EZ)]
Distortion :	Less than 1.5% [at 98.0MHz]
Auto stop level :	20dB ± 10dB [at 98.0MHz]
Stereo separation :	More than 25dB [at 98.0MHz (HE, HK, HR, G, LH, U)] More than 20dB [at 98.0MHz (EE, K, EZ)]
Intermediate frequency :	10.7MHz

<AM(MW) SECTION>

Sensitivity : (S/N 20 dB)	48 ~ 62dB [at 603kHz (HE, HK, HR, EE, K, EZ)] [at 620kHz (G, LH, U)] 47 ~ 59dB [at 999kHz (HE, HR, HK, EE, K, EZ)] [at 1000kHz (G, LH, U)] 47 ~ 59dB [at 1404kHz (HE, HR, HK, EE, K, EZ)] [at 1410kHz (G, LH, U)]
Signal to noise ratio :	More than 36dB [at 999kHz (HE, HR, HK, EE, K, EZ)] [at 1000kHz (G, LH, U)]
Distortion :	Less than 1.5% [at 999kHz (HE, HR, HK, EE, K, EZ)] [at 1000kHz (G, LH, U)]
Auto stop level :	55dB ± 10dB [at 999kHz (HE, HR, HK, EE, K, EZ)] [at 1000kHz (G, LH, U)]
Intermediate frequency :	450kHz

<LW SECTION>(EE, K, EZ only)

Sensitivity : (S/N 20dB)	66dB ± 5dB [at 144kHz] 63dB ± 5dB [at 198kHz] 62dB ± 5dB [at 290kHz]
Signal to noise ratio :	More than 32dB [at 198kHz]
Distortion :	Less than 1.5% [at 198kHz]
Auto stop level :	60dB ± 10dB [at 198kHz]
Intermediate frequency :	450kHz

<DECK SECTION>

Tape speed :	3000Hz ± 45Hz
Wow & flutter :	Less than 0.35% (R.M.S)
Take-up torque :	30 ~ 55g-cm (FWD, REV)
F.F & REW torque :	75 ~ 180g-cm
Back tension :	2 ~ 7g-cm (FWD, REV)
PB output level :	2.8V ± 3dB (SP OUT 2V)
REC/PB output level :	2.0V ± 3dB (SP OUT 2V)
Distortion (REC/PB) :	Less than 2.0%
Noise level (PB) :	Less than 110mV (NORM, SP OUT 2V) Less than 80mV (CrO ₂ , SP OUT 2V)
Noise level (REC/PB) :	Less than 30mV/10mV (DIN/WTD, NORM, SP OUT 2V) Less than 20mV/8mV (DIN/WTD, CrO ₂ , SP OUT 2V)
Crosstalk :	More than 60dB (1kHz, 0VU)
Channel separation :	More than 40dB (1kHz, 0VU)
Erasing ratio :	More than 60dB (at 125Hz)
Test tape :	TTA-602 (NORMAL) TTA-610 (CrO ₂)

TEST MODE

1. How to Activate CD Test Mode



- 1) Insert the AC plug while pressing the function CD button.
- 2) All FL display tubes will light up, and initialization will be started. (Initialize time: approx. 80 seconds)

2. How to cancel CD Test Mode

- Either one of the following operations will cancel the CD test mode.
- Press the function button.
 - Press the power switch button.
 - Disconnect the AC plug.

3. CD Test Mode Functions

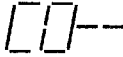
When test mode is activated, the following mode functions from No. 1 to No. 5 can be used by pressing the operation keys.

Mode / No.	Operation	FL display	Operation	Contents
Start mode No. 1	Test mode activation	All FL light up	<ul style="list-style-type: none"> • Laser diode illuminated under normal circumstances <p>(CD block power supply ON)</p>	<p>Displays the machine mode that it is a test mode.</p> <p>All FL displays light up</p> <ul style="list-style-type: none"> • Laser current measurement (Across R29 100 ohms resistor)
Search mode No. 2	■ key		<ul style="list-style-type: none"> • Continual focus search * NOTE 1 (The pickup lens repeats the full-swing up-down motion.) * Avoid continual searches that last for more than 10 minutes. 	<p>FOCUS SERVO</p> <ul style="list-style-type: none"> • Check focus search waveform (OSC1 terminal) • Check focus error waveform (FE1 terminal)
Play mode No. 3	▶ key		<ul style="list-style-type: none"> • Normal playback • Focus search is continued if TOC cannot be read * NOTE 1 	<p>FOCUS SERVO / TRACKING SERVO CLV SERVO / SLED SERVO</p> <p>Check FOK (SEL terminal)</p>
Traverse mode No. 4	key		<ul style="list-style-type: none"> • During normal disc playback Press once; tracking servo OFF Press twice; tracking servo ON * NOTE 2 	<p>TRACKING SERVO ON / OFF</p> <p>Tracking balance (traverse) adjustment</p>
Sled mode No. 5	◀◀ key ▶▶ key	All FL light up	<ul style="list-style-type: none"> • Pickup moves to the outermost track • Pickup moves to the innermost track * NOTE 3 <p>(During playback, machine operates normally.)</p>	<p>SLED SERVO</p> <p>Check SLED mechanism operation</p>

* NOTE 1: There are cases when the tracking servo cannot be locked owing to the protection circuit being operated when heat builds up in the driver IC if the focus search is operated continually for more than 10 minutes. In these cases, the power supply should be switched off for 10 minutes until heat has been reduced and then re-started.

* NOTE 2: Do not press the ◀◀ or ▶▶ keys when the machine is in the || status is active. If they are pressed, playback will not be possible after the || status has been canceled. If the ◀◀ or ▶▶ keys are pressed in the || status, press the ■ key and return to start mode (No. 1).

* NOTE 3: When pressing the ◀◀ or ▶▶ keys, take care to avoid damage to the gears. Because the sled motor is activated when the ◀◀ or ▶▶ keys are pressed, even when the pick-up is at the outermost or innermost track.

* NOTE 4: Press the eject key if the CD changer mechanism is jammed while initializing.

* NOTE 5: Disc cannot be changed during the test mode. (Use the first disc tray)

4. Operation Outline

The operation of each mode is carried out in the direction of the arrows from the start mode as indicated in the following illustration.

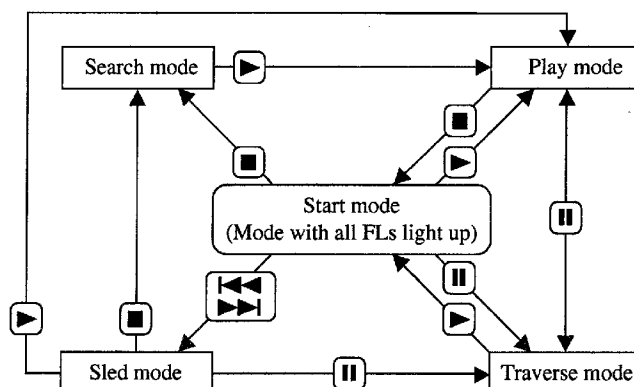

CD TROUBLE-SHOOTING

Flow Chart

- * When the TEST MODE cannot be initiated,
 - CD functions will not operate
 - Check the system control circuit
 - Abnormality in the CD block power supply circuit
 - Pin 406 +12V
- * Reference: IC check-point terminals

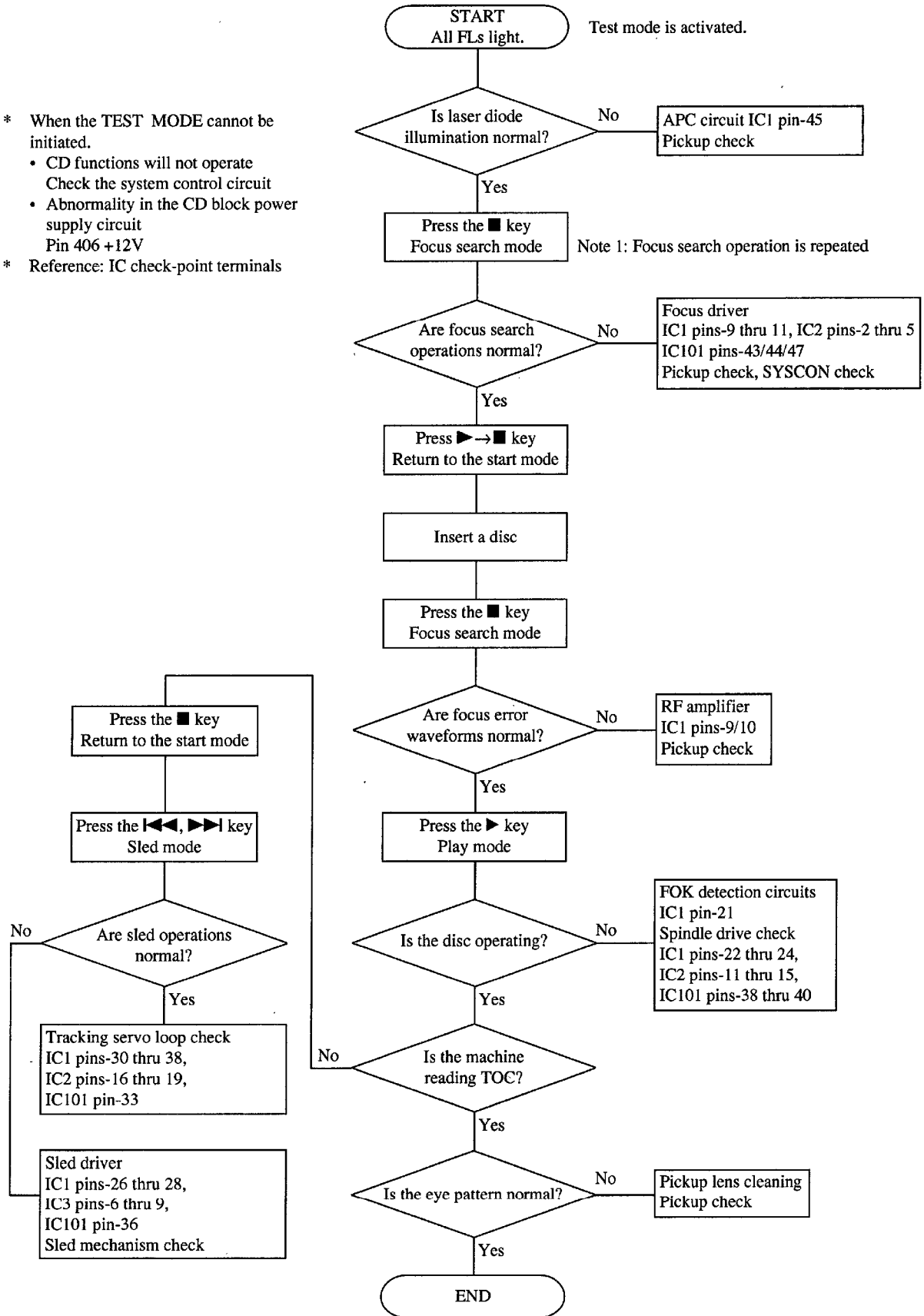

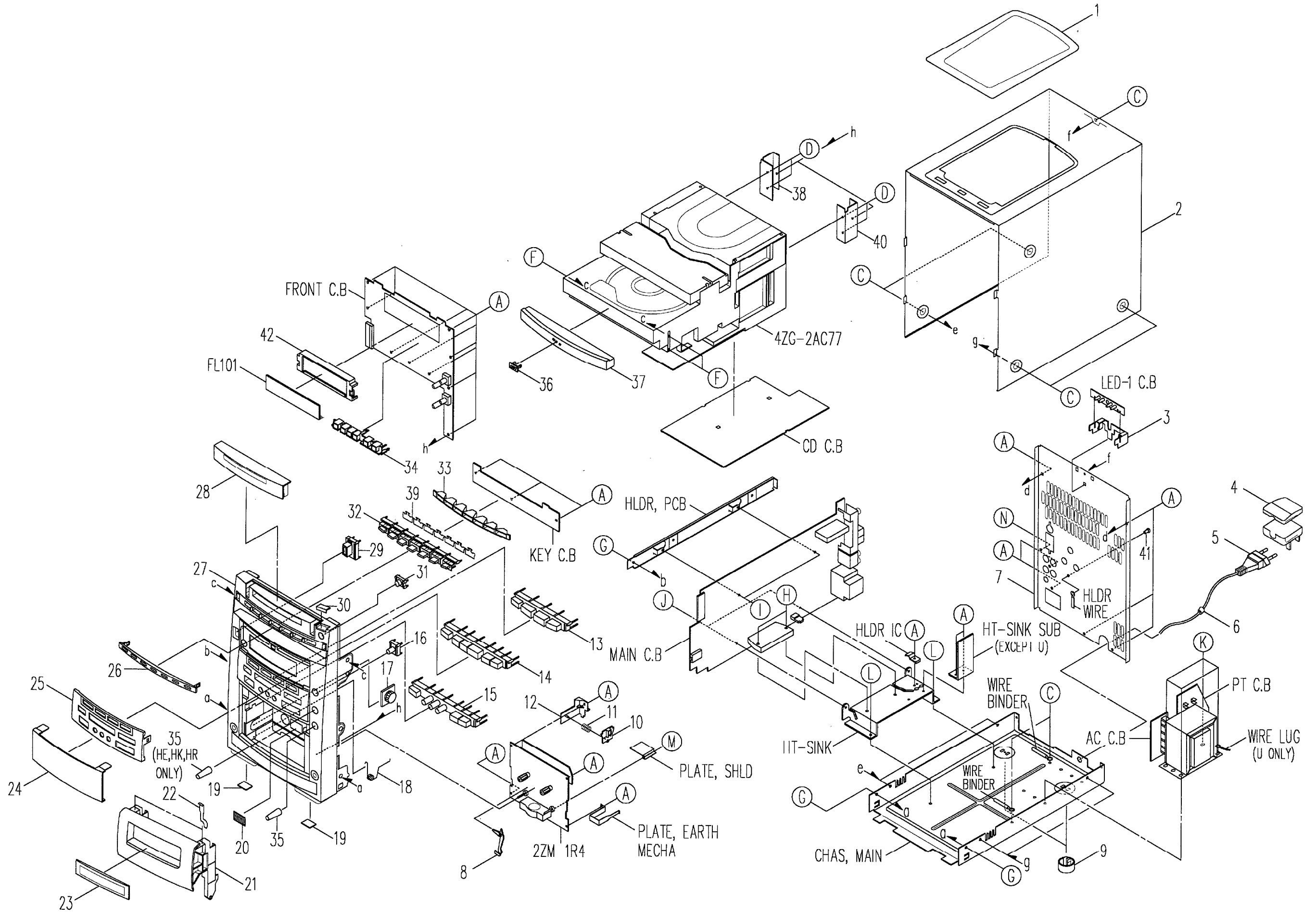

MECHANICAL PARTS LIST 1 / 1

If can't understand for Description please kindly refer to "REFERENCE NAME LIST".

REF. NO.	PART NO.	KANRI NO.	DESCRIPTION	REF. NO.	PART NO.	KANRI NO.	DESCRIPTION
1	85-CL5-019-019		WINDOW, TOP	24	85-CL5-020-019		WINDOW, DISP
2	85-CL5-002-019		CAB, STEEL	25	85-CL5-024-019		PANEL, FR
3	85-CL5-212-019		HLDR, LED	26	85-CL5-026-019		PANEL, CD
4	87-099-811-018		PLUG, ADPTR CONV(K)<HK>	27	85-CL5-001-119		CAB, FR<K, EE, LH, G, EZ>
△ 5	87-050-079-019		AC CORD ASSY, E<EXCEPT U, K, G>	27	85-CL5-027-119		CAB, FR H<HE, HK, HR>
△ 5	87-050-081-119		AC CORD ASSY, G<G>	27	85-CL5-025-119		CAB, FR U<U>
△ 5	87-050-100-019		AC CORD ASSY, K3P<K>	28	85-CL5-022-019		WINDOW, CD
△ 5	87-050-053-019		AC CORD ASSY, U-2<U>	29	85-CL5-005-019		KEY, POWER
6	87-085-185-010		BUSHING, AC CORD E<EXCEPT U>	30	85-CL5-007-019		KEY, DISC
6	87-085-189-019		BUSHING, AC CORD U<U>	31	85-CL5-006-019		KEY, OPEN
7	85-CL5-031-019		PANEL, REAR EEBN<EE>	32	85-CL5-008-019		KEY, CD
7	85-CL5-033-019		PANEL, REAR EZBN<EZ>	33	85-CL5-205-019		GUIDE, LED CD
7	85-CL5-039-019		PANEL, REAR GBN<G>	34	85-CL5-206-019		GUIDE, LED PLAY
7	85-CL5-037-019		PANEL, REAR HFJBN<HE>	35	85-CL5-018-019		KNOR, MIC
7	85-CL5-038-019		PANEL, REAR HKJBN<HK>	36	82-NE6-067-019		BADGE AIWA 30N
7	85-CL5-052-019		PANEL, REAR HRJBN<HR>	37	85-CL5-004-119		PANEL, TRAY
7	85-CL5-035-119		PANEL, REAR KBN<K>	38	85-CL5-209-019		HLDR, CD1
7	85-CL5-036-019		PANEL, REAR LHBN<LH>	39	85-CL5-023-019		SH, CD
7	85-CL5-030-019		PANEL, REAR UBN<U>	40	85-CL5-210-019		HLDR, CD2
8	82-ZM1-263-119		LVR, EJECT L	41	87-084-077-019		NYLON RIVET DIA 3.5-4.5
9	81-675-010-010		FOOT, H10	42	82-NF7-210-019		GUIDE, FL
10	82-NF5-229-019		PLATE, LOCK	A	87-067-703-019		BVT 2+3-10(W/O SLOT)
11	82-NF5-228-019		SPR-C, LOCK	B	87-751-096-419		VT 2+3-10 GLD
12	82-NF5-226-019		HLDR LOCK 1N	C	87-067-641-019		UTT 2+3-8 W/O SLOT BLK
13	85-CL5-012-019		KEY ASSY, FUN	D	87-067-579-019		BVT 2+3-8 W/O SLOT
14	85-CL5-010-019		KEY, PLAY	E	87-078-019-019		S-SCREW, IT +4-6
15	85-CL5-009-219		KEY, AMP	F	87-721-097-419		QT 2+3-12 GLD
16	85-CL5-011-019		KEY, KARAOKE	G	87-591-094-419		QIT + 3-6 GOLD
17	87-063-165-019		OIL-DMPR 150	H	87-067-581-019		BVT 2+3-15 W/O SLOT
18	84-CF3-207-219		SPR-T, EJECT	I	87-078-084-019		BVTT +3-6 W, CONVEX
19	80-VT1-202-019		FELT, 12.5-15.5-2	J	87-067-633-019		BVT 2+3-8 W/CONVEX
20	81-532-080-019		LBL, CASS-COMPT	K	87-751-092-419		VT 2+3-4
21	85-CL5-003-019		BOX, CASS	L	87-067-584-019		BVT 2+3-6 W/O SLOT
22	80-CD3-218-110		SPR-P, CASS	M	87-571-032-419		VIT +2-3
23	85-CL5-021-019		WINDOW, CASS	N	87-571-092-419		VIT +3-4

CD MECHANISM EXPLODED VIEW 1/2

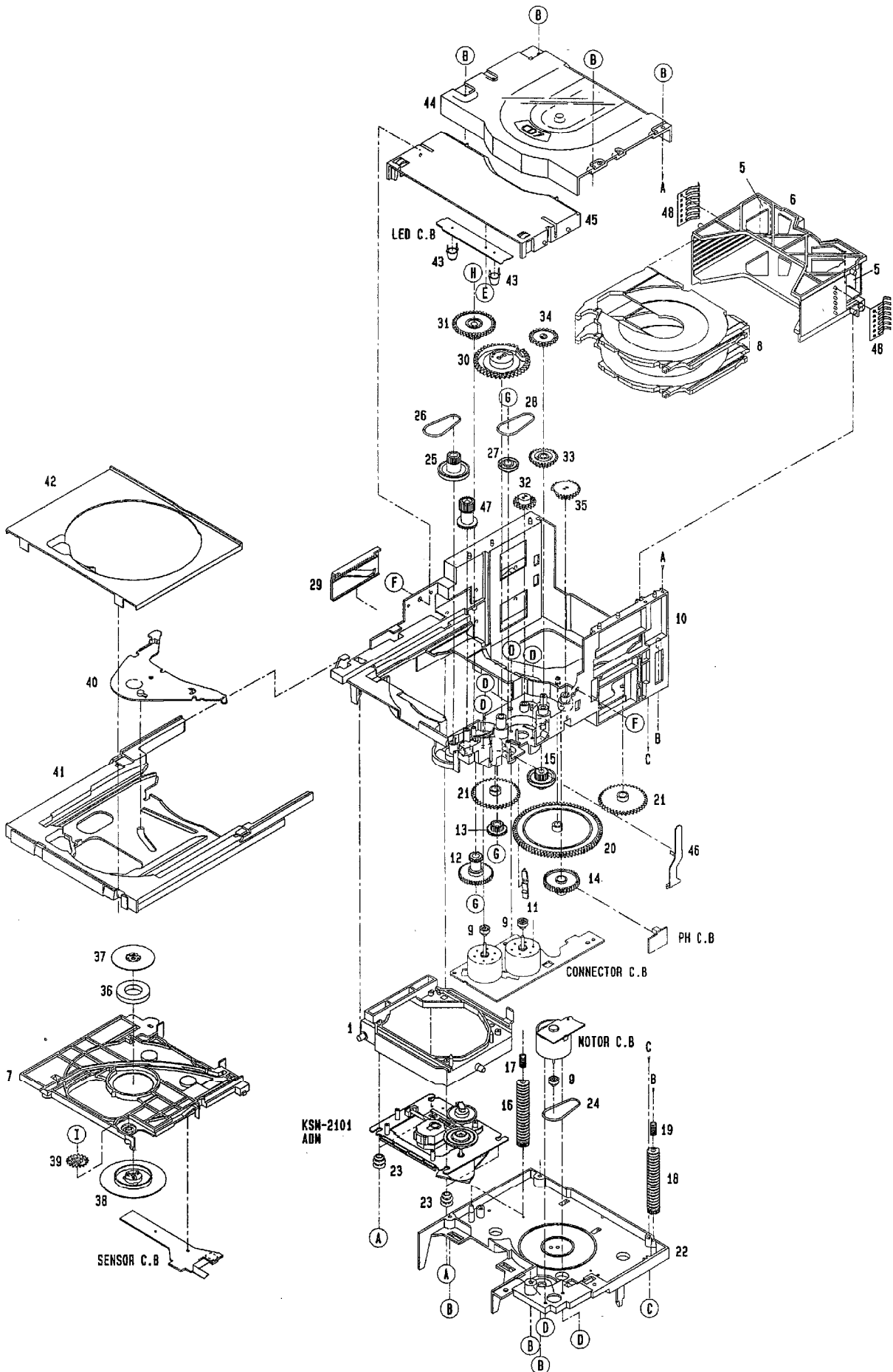

CD MECHANISM PARTS LIST 1 / 2

If can't understand for Description please kindly refer to "REFERENCE NAME LIST".

REF. NO.	PART NO.	KANRI NO.	DESCRIPTION	REF. NO.	PART NO.	KANRI NO.	DESCRIPTION
1	84-ZG2-205-010		HLLDR, MECH	34	84-ZG2-217-010		GEAR, MECH-B
5	84-ZG2-237-010		CLOTH, BOX	35	84-ZG2-216-010		GEAR, MECH-A
6	84-ZG2-203-010		BOX, TRAY	36	87-036-326-010		MAGNET, CLAMPER 93
7	84-ZG2-204-010		HLLDR, MAGNET	37	81-ZG1-229-110		PLATE, MAGNET
8	84-ZG2-006-010		TRAY, DISC	38	81-ZG1-228-210		HLLDR, MAGNET
9	84-ZG2-228-010		PULLEY, MOT	39	84-ZG2-222-010		GEAR, CAM LOCK
10	84-ZG2-201-010		CHAS, MECH	40	84-ZG2-003-010		LVR, TRAY
11	84-ZG2-225-010		LVR, A	41	84-ZG2-001-010		TRAY, L
12	84-ZG2-213-010		GEAR, TRAY LOAD-B	42	84-ZG2-002-010		TRAY, COVER
13	84-ZG2-214-010		GEAR, TRAY LOAD-C	43	84-ZG2-240-010		COVER, LED 2
14	84-ZG2-209-010		GEAR, UP DOWN-B	44	84-ZG2-011-010		COVER, TOP S
15	84-ZG2-208-010		GEAR, UP DOWN-A	45	84-ZG2-010-010		COVER, LED
16	84-ZG2-206-010		GEAR, CAM BOX 1	46	84-ZG2-226-010		LVR, B
17	84-ZG2-238-010		SPR-C, G-BOX 1	47	84-ZG2-212-010		GEAR, TRAY LOAD-A
18	84-ZG2-207-010		GEAR, CAM BOX 2	48	84-ZG2-232-010		SPR-P, LOCK
19	84-ZG2-239-010		SPR-C, G-BOX 2	A	81-ZG1-271-010		S-SCREW, MECH REAR
20	84-ZG2-210-010		GEAR, UP DOWN-C	B	87-067-703-010		BVT2+3-10 (W/O SLOT)
21	84-ZG2-211-010		GEAR, UP DOWN-D	C	87-067-822-010		BVT 2+3-20W/O SLOT
22	84-ZG2-202-010		CHAS, BOTTOM	D	87-251-071-410		U+2.6-4
23	80-CD3-214-010		CUSH CD A	E	87-067-584-010		BVT2+3-6
24	84-ZG2-231-010		BELT, SQ-C	F	87-721-097-410		QT2+3-12 GLD
25	84-ZG2-221-010		GEAR, MECH-F	G	87-067-828-010		VFT2+3-15DIA10, GLD
26	84-ZG2-229-010		BELT, SQ-A	H	87-078-061-010		VFT2+3-20DIA10, GLD
27	84-ZG2-215-010		GEAR, TRAY LOAD-D	I	87-761-097-410		VFT2 +3-12
28	84-ZG2-230-010		BELT, SQ-B				
29	84-ZG2-224-010		CAM, SL				
30	84-ZG2-223-010		GEAR, CAM				
31	84-ZG2-220-010		GEAR, MECH-E				
32	84-ZG2-219-010		GEAR, MECH-D				
33	84-ZG2-218-010		GEAR, MECH-C				

CD MECHANISM EXPLODED VIEW 2 / 2

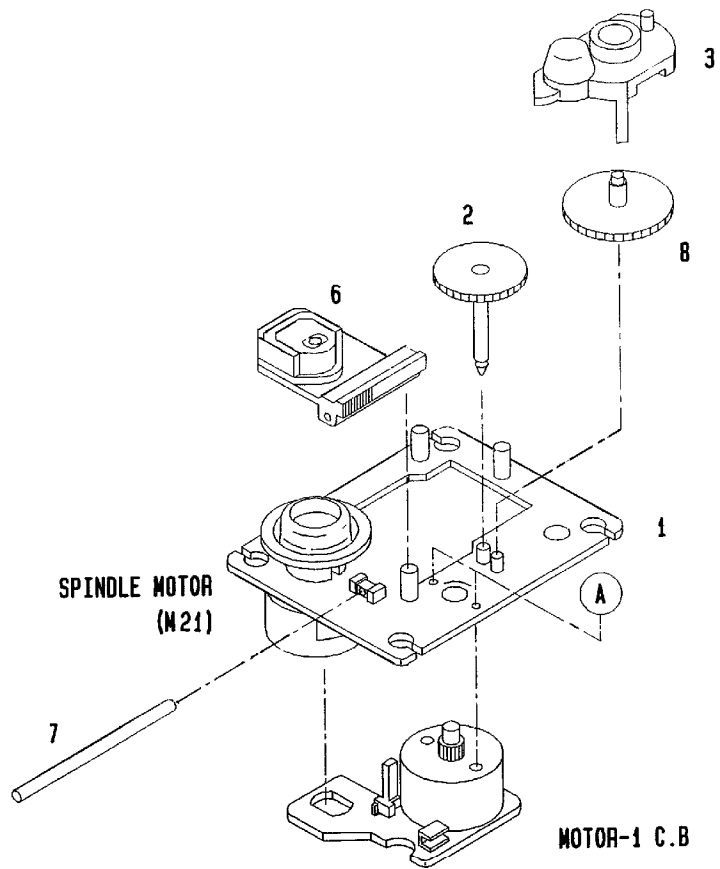

CD MECHANISM PARTS LIST 2 / 2

If can't understand for Description please kindly refer to "REFERENCE NAME LIST".

REF. NO.	PART NO.	KANRI NO.	DESCRIPTION
1	9X-262-587-110		MOTOR CHASSIS ASSY
2	92-625-188-020		GEAR(A)
3	92-625-544-010		COVER
6	98-848-127-110		OPTICAL PICK UP KSS-210A
7	92-626-908-010		SHAFT SLED
8	92-626-081-010		GEAR B
A	87-261-032-210		V+2-3

TAPE MECHANISM EXPLODED VIEW 1 / 1

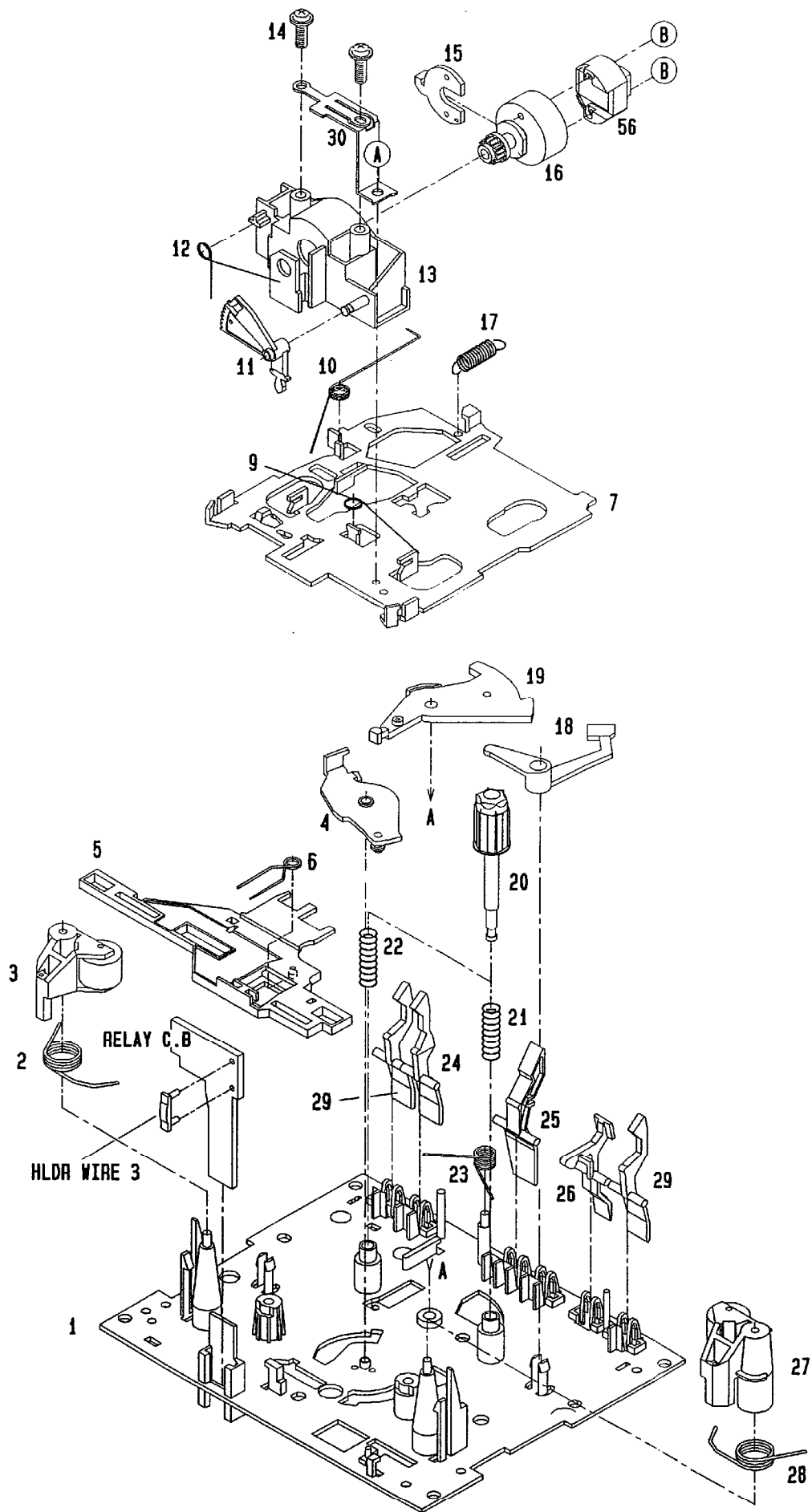

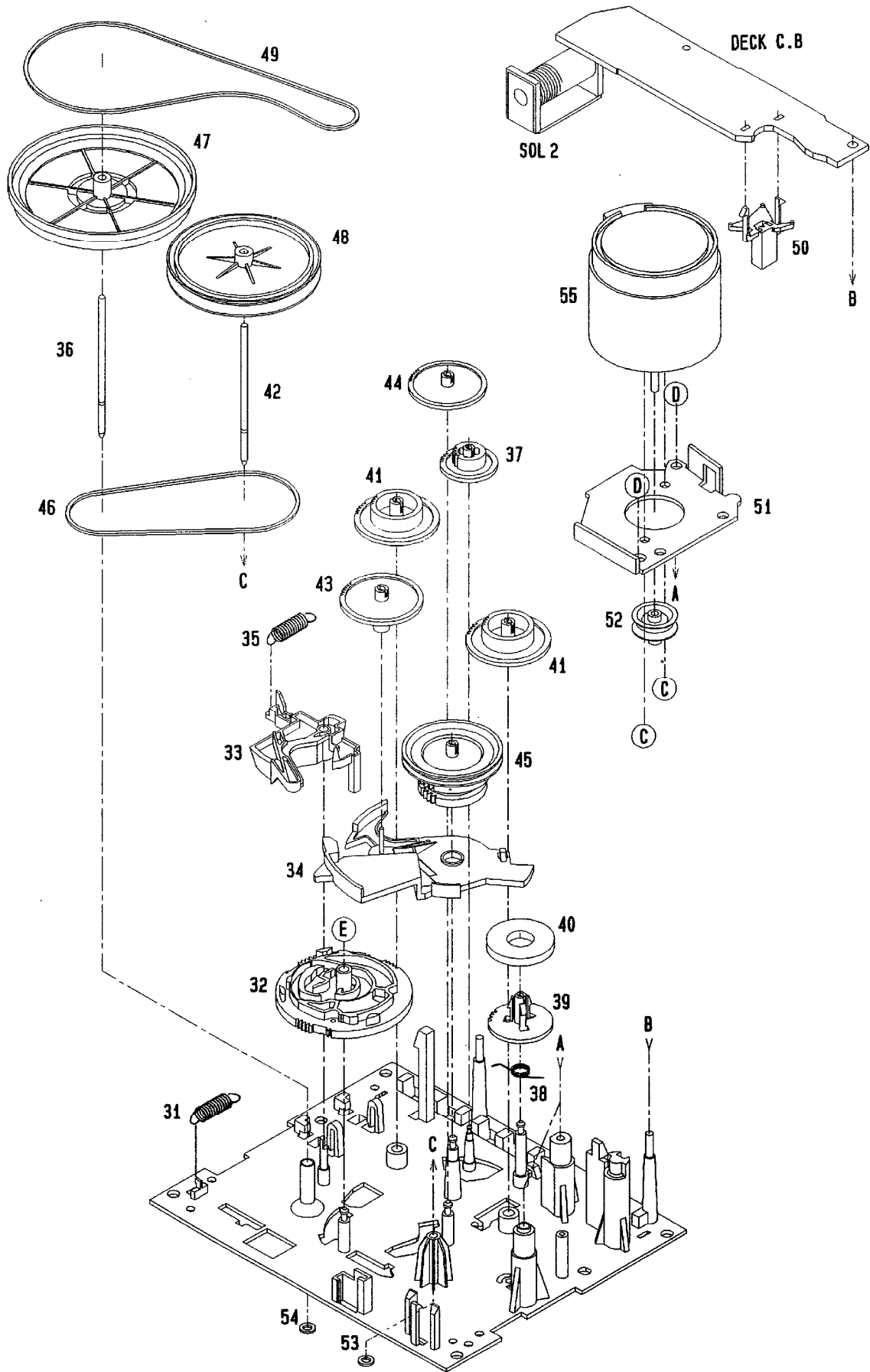

TAPE MECHANISM PARTS LIST 1 / 1

If can't understand for Description please kindly refer to "REFERENCE NAME LIST".

REF. NO.	PART NO.	KANRI NO.	DESCRIPTION	REF. NO.	PART NO.	KANRI NO.	DESCRIPTION
1	82-ZM1-299-110		CHAS ASSY, R	32	82-ZM1-221-110		GEAR, CAM
2	82-ZM1-258-010		SPR-T, PINCH L	33	82-ZM1-227-210		LVR, TRIG
3	82-ZM1-248-510		LVR ASSY, PINCH L	34	82-ZM1-224-410		LVR, FR
4	82-ZM1-295-310		PLATE ASSY, LINK	35	82-ZM1-305-110		SPR-E, TRIG 2
5	82-ZM1-266-110		LVR, DIR	36	82-ZM1-312-019		CAPSTAN, N 2.2-41.7
6	82-ZM1-214-010		SPR-T, DIR	37	82-ZM1-223-010		GEAR, PLAY
7	82-ZM1-206-610		CHAS, HEAD	38	82-ZM1-322-010		SPR-T, FR 60
9	82-ZM1-269-210		SPR-T, BRG	39	82-ZM1-220-210		GEAR, IDLER
10	82-ZM1-219-110		SPR-T, LINK	40	82-ZM1-316-010		RING MAGNET 3
11	82-ZM1-210-110		GEAR, H T	41	82-ZM1-216-310		GEAR, REEL
12	82-ZM1-213-010		SPR-T, HEAD	42	82-ZM1-313-019		CAPSTAN, N 2-41.5
13	82-ZM1-207-610		GUIDE, TAPE	43	82-ZM1-225-010		GEAR, FR
14	82-ZM1-283-310		S-SCREW, AZIMUTH	44	82-ZM1-226-010		GEAR, REW
15	82-ZM1-314-119		PLATE, HEAD	45	82-ZM1-228-610		SLIP DISK ASSY
16	82-ZM1-208-010		HLDR, HEAD	46	82-ZM1-334-010		BELT, FR 3
17	82-ZM1-218-010		SPR-E, HB	47	82-ZM1-238-610		FLY-WHL ASSY, R
18	82-ZM1-264-010		LVR, EJECT R (DECK 1)	48	82-ZM1-235-310		FLY-WHL ASSY, L
19	82-ZM1-222-210		LVR, PLAY	49	82-ZM1-260-010		BELT, MAIN
20	82-ZM1-217-310		REEL TABLE	50	82-ZM1-245-210		HLDR, IC
21	82-ZM1-244-510		SPR-C, BT	51	82-ZM1-246-010		HLDR, MOTOR
22	82-ZM1-285-410		SPR-C, BT L	52	82-ZM1-247-110		PULLEY, MOTOR
23	82-ZM1-257-010		SPR-T, CAS	53	82-ZM1-288-010		SH, 1.63-3.2-0.5 SLT
24	82-ZM1-241-310		LVR, MC	54	80-ZM6-243-010		SH, 1.75-3.6-0.5 SLT
25	82-ZM1-242-010		LVR, CAS	55	87-045-348-010		MOT, SHW 2L 70(M1)
26	82-ZM1-243-010		LVR, STOP	56	87-046-414-019		HEAD, RPH KC9242(RPH)
27	82-ZM1-253-510		LVR ASSY, PINCH R	A	82-ZM1-315-010		S-SCREW, GUIDE TAPE
28	82-ZM1-259-010		SPR-T, PINCH R	B	80-ZM6-207-010		V+1.6-7
29	82-ZM1-240-110		LVR, REC	C	87-251-070-410		U+2.6-3
30	82-ZM1-298-010		SPR-P, EARTH	D	87-741-073-410		UT2+2.6-6 GLD
31	82-ZM1-255-310		SPR-E, LVR DIR	E	82-ZM1-597-010		PW, 2.15-6.8-0.4 SLT

SPRING APPLICATION POSITION

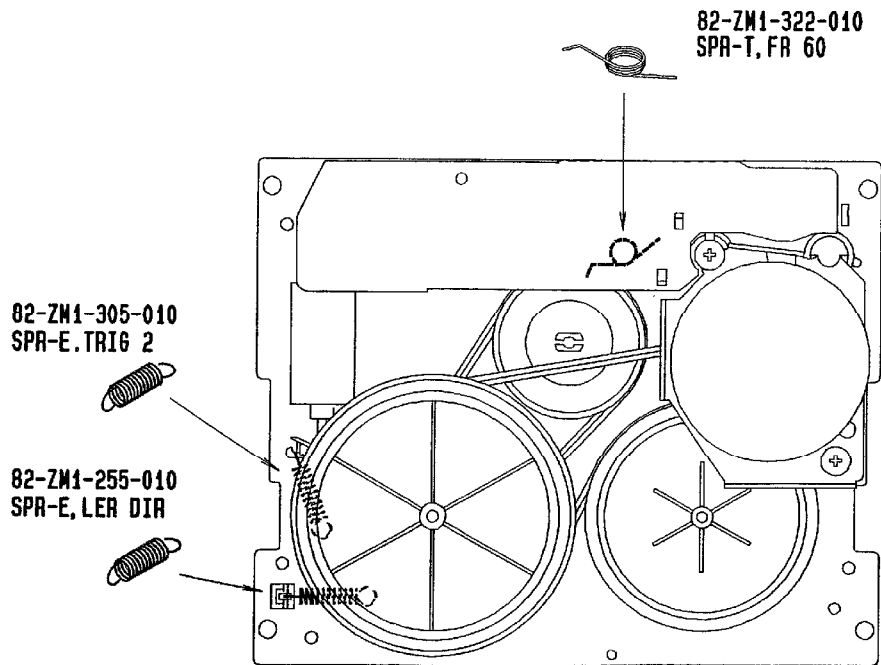
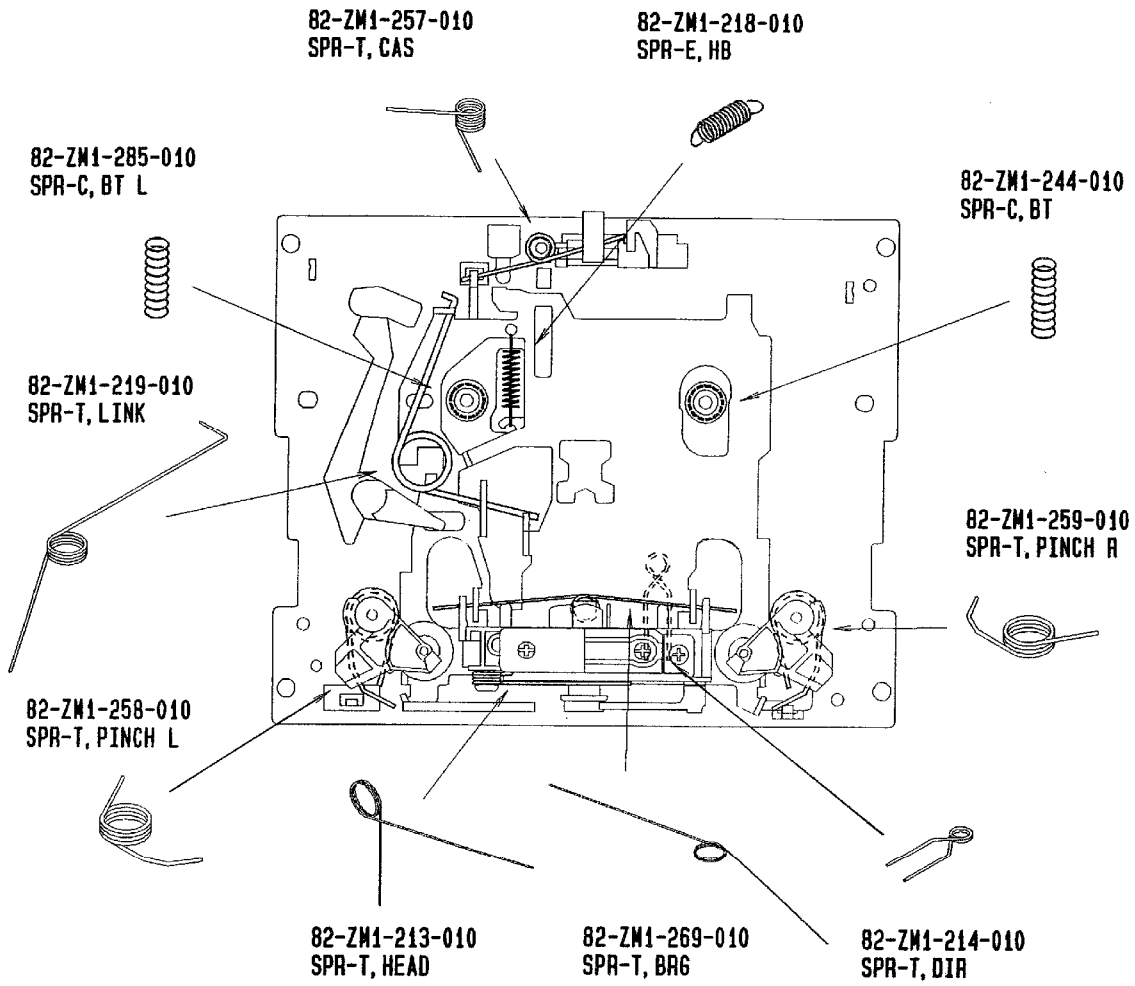

SPEAKER DISASSEMBLY INSTRUCTIONS

矢印の位置にマイナスドライバーを差し込んで、パネルをはずして、各々のスピーカー・ユニットのビスを取り、スピーカー・ユニットをはずしてください。

Insert a flat - bladed screwdriver into the position indicated by the arrows and remove the panel.

Remove the screws of each speaker unit and then remove the speaker units.

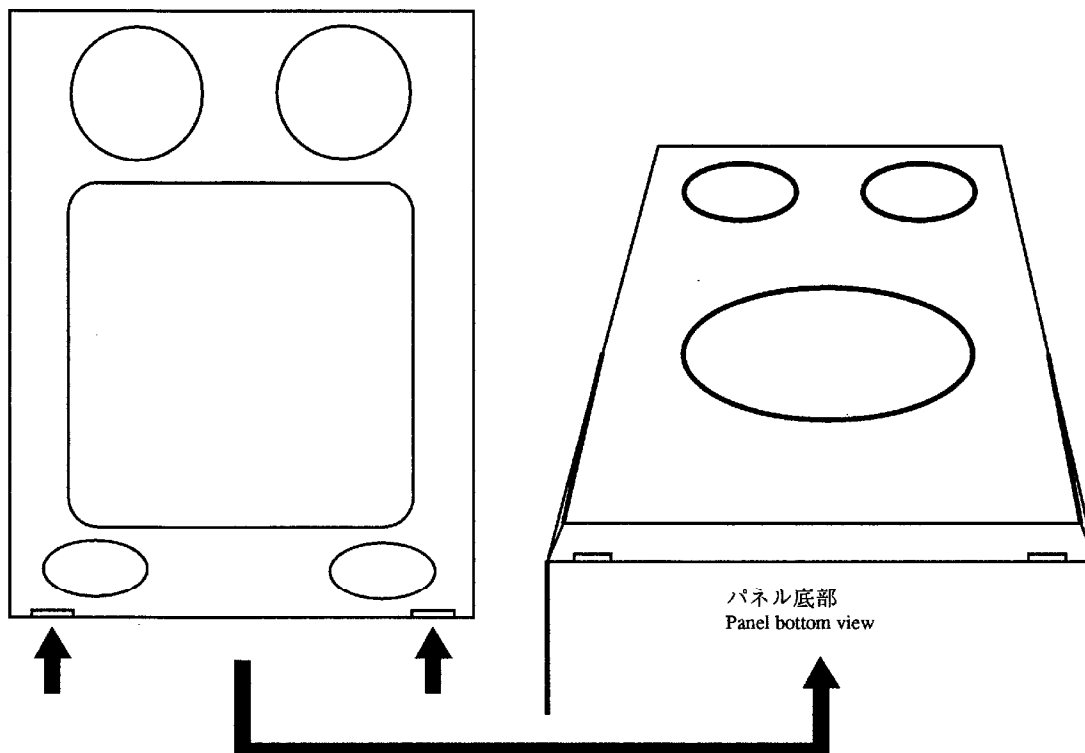

SPEAKER PARTS LIST (SX-SL700)

If can't understand for Description please kindly refer to "REFERENCE NAME LIST".

REF. NO.	PART NO.	KANRI NO.	DESCRIPTION	REF. NO.	PART NO.	KANRI NO.	DESCRIPTION
1	85-CP5-014-010		SPEAKER GRILL R	6	85-CP5-604-010		SPEAKER TWEETER
2	85-CP5-015-010		SPEAKER GRILL L	7	85-CP5-606-010		CERAMIC
3	85-CP5-019-010		GRILL FRAME ASSY R	8	85-CP5-611-010		SPEAKER CORD Y/B
4	85-CP5-020-010		GRILL FRAME ASSY L	9	83-096-614-010		SPEAKER CORD
5	85-CP6-602-010		SPEAKER WOOFER				

ACCESSORIES / PACKAGE LIST

If can't understand for Description please kindly refer to "REFERENCE NAME LIST".

REF. NO.	PART NO.	KANRI NO.	DESCRIPTION
1	85-CF5-652-019	RC, RC-T515	
2	85-CF5-902-119	IB, ESC(S) <EXCEPT U>	
2	85-CF5-903-119	IB, GFI(S) <EE, EZ>	
2	85-CF5-905-119	IB, U-ESF(S) <U>	
3	87-043-115-01B	ANT, FEEDER FM <EXCEPT K, EE, EZ>	
3	87-043-106-019	FM WIRE ANT(Z) <K, EE, EZ>	
4	87-006-225-019	AM LOOP ANT NC2	
5	87-099-789-019	PLUG, ADPTR IR44 <LH, HE, HR>	

REFERENCE NAME LIST

ELECTRICAL SECTION

DESCRIPTION	REFERENCE NAME
ANT	ANTENNAS
C-	CHIP
C-CAP	CAP, CHIP
C-CAP TN	CAP, CHIP TANTALUM
C-COIL	COIL, CHIP
C-DI	DIODE, CHIP
C-DIODE	DIODE, CHIP
C-FET	FET, CHIP
C-FOTR	FILTER, CHIP
C-JACK	JACK, CHIP
C-LED	LED, CHIP
C-RES	RES, CHIP
C-SFR	SFR, CHIP
C-SLIDE SW	SLIDE SWITCH, CHIP
C-SW	SWITCH, CHIP
C-TR	TRANSISTOR, CHIP
C-VR	VOLUME, CHIP
C-ZENER	ZENER, CHIP
CAP, CER	CAP, CERA-SOL
CAP, E	CAP, ELECT
CAP, M/F	CAP, FILM
CAP, TC	CAP, CERA-SOL
CAP, TC-U	CAP, CERA-SOL SS
CAP, TN	CAP, TANTALUM
CERA FIL	FILTER, CERAMIC
CF	FILTER, CERAMIC
DL	DELAY LINE
E/CAP	CAP, ELECT
FILT	FILTER
FLTR	FILTER
FUSE RES	RES, FUSE
MOT	MOTOR
P-DIODE	PHOTO DIODE
P-SNSR	PHOTO SENSER
P-TR	PHOTO TRANSISTOR
POLY VARI	VARIABLE CAPACITOR
PPCAP	CAP, PP
PT	POWER TRANSFORMER
PTR, RES	PTR, MELF
RC	REMOTE CONTROLLER
RES NF	RES, NON-FLAMMABLE
RESO	RESONATOR
SHLD	SHIELD
SOL	SOLENOID
SPKR	SPEAKER
SW, LVR	SWITCH, LEVER
SW, RTRY	SWITCH, ROTARY
SW, SL	SWITCH, SLIDE
TC CAP	CAP, CERA-SOL
THMS	THERMISTOR
TR	TRANSISTOR
TRIMER	CAP, TRIMMER
TUN-CAP	VARIABLE CAPACITOR
VIB, CER	RESONATOR, CERAMIC
VIB, XTAL	RESONATOR, CRYSTAL
VR	VOLUME
ZENER	DIODE, ZENER

MECHANICAL SECTION

DESCRIPTION	REFERENCE NAME
ADHESHIV	SHEET ADHESHIVE
AZ	AZIMUTH
BAR-ANT	BAR-ANTENNA
BAT	BATTERY
BATT	BATTERY
BRG	BEARING
BTN	BUTTON
CAB	CABINET
CASS	CASSETTE
CHAS	CHASSIS
CLR	COLLAR
CONT	CONTROL
CRSR	CURSOR
CU	CUSHION
CUSH	CUSHION
DIR	DIRECTION
DUBB	DUBBING
FL	FRONT LOADING
FLY-WHL	FLYWHEEL
FR	FRONT
FUN	FUNCTION
G-CU	G-CUSHION
HDL	HANDOL
HIMERON	CLOTH
HINGE, BAT	HINGE, BATTERY
HLDR	HOLDER
HT-SINK	HEAT SINK
IB	INSTRUCTION BOOKLET
IDLE	IDLER
IND, L-R	INDICATOR, L-R
KEY, CONT	KEY, CONTROL
KEY, PRGM	KEY, PROGRAM
KNOB, SL	KNOB, SLIDE
LBL	LABEL
LID, BATT	LID, BATTERY
LID, CASS	LID, CASSETTE
LVR	LEVER
P-SP	P-SPRING
PANEL, CONT	PANEL, CONTROL
PANEL, FR	PANEL, FRONT
PRGM	PROGRAM
PULLY, LOAD MO	PULLY, LOAD MOTOR
RBN	RIBBON
S-	SPECIAL
SEG	SEGMENT
SH	SHEET
SHLD-SH	SHIELD-SHEET
SL	SLIDE
SP	SPRING
SP-SCREW	SPECIAL-SCREW
SPACER, BAT	SPACER, BATTERY
SPR	SPRING
SPR-P	P-SPRING
SPR-PC-PUSH	P-SPRING, C-PUSH
T-SP	T-SPRING
TERM	TERMINAL
TRIG	TRIGGER
TUN	TUNING
VOL	VOLUME
W	WASHER
WHL	WHEEL
WORM-WHL	WORM-WHEEL

サービス技術ニュース	
番号	連絡内容
G-	-
G-	-
G-	-

アイワ株式会社
AIWA CO.,LTD.

9420025, 750038

Tokyo Japan

〒110 東京都台東区池之端1-2-11 ☎03 (3827) 3111 (代表)

Printed in Singapore