

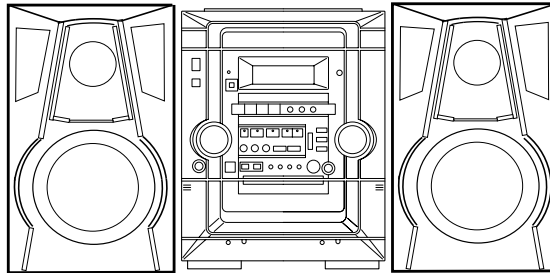

<b><u>NSX-AJ24</u></b>	U
<b><u>NSX-BL23</u></b>	LH
<b><u>NSX-BL24</u></b>	LH, HS
<b><u>NSX-BL34</u></b>	LH
<b><u>NSX-BL24E</u></b>	HA
<b><u>NSX-BL34E</u></b>	HA



# SERVICE MANUAL

COMPACT DISC STEREO SYSTEM

BASIC TAPE MECHANISM : ZZM-3  
BASIC CD MECHANISM : AZG-1

- This Service Manual is the "Revision Publishing" and replaces "Simple Manual".  
NSX-AJ24 <U> / BL24 <LH> (S/M Code No. 09-003-426-1T1)  
NSX-BL23 <LH> / BL34 <LH> (S/M Code No. 09-004-426-1T4)  
NSX-BL24 <HS> (S/M Code No. 09-004-426-1T5)
- If requiring information about the CD mechanism, see Service Manual of AZG-1.  
AZG-1 ZD8RDC (S/M Code No. 09-001-335-3NA)  
AZG-1 YZD8RDM (S/M Code No. 09-001-335-3N6)  
AZG-1 ZD4RDC (S/M Code No. 09-001-335-3N8)

# aiwa

S/M Code No. 09-005-426-1R1

REVISION

DATA

SYSTEM COMBINATION TABLE

SYSTEM	CD CASSEIVER	SPEAKER	TAPE MECHANISM	CD MECHANISM	REMOTE CONTROLLER
NSX-AJ24	CX-NAJ24	SX-NAJ25 SX-R140	ZZM-3 YPR1NC	AZG-1 ZD8RDC	RC-ZAS02
NSX-BL23	CX-NBL23	SX-NBL25	ZZM-3 YPR1NM	AZG-1 YZD8RDM	
NSX-BL24	CX-NBL24		ZZM-3 YPR1NC	AZG-1 ZD8RDC	
NSX-BL34	CX-NBL34	SX-NBL42		AZG-1 ZD8RDC	
NSX-BL24E	CX-NBL24E	SX-NBL25		AZG-1 ZD4RDC	
NSX-BL34E	CX-NBL34E	SX-NBL42			

# SPECIFICATIONS

## Main unit

### <FM Tuner section>

**Tuning range** 87.5 MHz to 108 MHz  
**Usable sensitivity (IHF)** 13.2 dBf  
**Antenna terminals** 75 ohms (unbalanced)

### <AM Tuner section>

**Tuning range** 530 kHz to 1710 kHz (10 kHz step)  
 531 kHz to 1602 kHz (9 kHz step)  
**Usable sensitivity** 350 µV/m  
**Antenna** Loop antenna

### <Amplifier section>

#### CX-NAJ24 <U>:

**Power output** 50 W + 50 W (50 Hz – 20 kHz,  
 T.H.D. less than 1 %, 6 ohms)  
 62 W + 62 W (1 kHz, T.H.D.  
 less than 10 %, 6 ohms)

**Total harmonic distortion** 0.08 %  
 (25 W, 1 kHz, 6 ohms, DIN AUDIO)

#### CX-NBL23/CX-NBL24 <LH>, CX-NBL24E <HA>:

**Power output** Rated: 40 W + 40 W  
 (6 ohms, T.H.D. 1 %, 1 kHz)  
 Reference: 50 W + 50 W  
 (6 ohms, T.H.D. 10 %, 1 kHz).

**Total harmonic distortion** 0.05 %  
 (25 W, 1 kHz, 6 ohms, DIN AUDIO)

#### CX-NBL34 <LH>, CX-NBL34E <HA>:

**Power output** Rated: 65 W + 65 W  
 (6 ohms, T.H.D. 1 %, 1 kHz)  
 Reference: 80 W + 80 W  
 (6 ohms, T.H.D. 10 %, 1 kHz).

**Total harmonic distortion** 0.05 %  
 (40 W, 1 kHz, 6 ohms, DIN AUDIO)

#### CX-NBL24 <HS>:

**Power output** Rated: 24 W + 24 W  
 (6 ohms, T.H.D. 1 %, 1 kHz)  
 Reference: 30 W + 30 W  
 (6 ohms, T.H.D. 10 %, 1 kHz).

**Total harmonic distortion** 0.08 %  
 (15 W, 1 kHz, 6 ohms, DIN AUDIO)

### Inputs

### Outputs

VIDEO/AUX: 500 mV  
 SPEAKERS: accepts speakers of  
 6 ohms or more  
 SURROUND SPEAKERS <U only> :  
 accepts speakers of 8 ohms to  
 16 ohms  
 PHONES (stereo jack): accepts  
 headphones of 32 ohms or more

### <Cassette deck section>

**Track format** 4 tracks, 2 channels stereo  
**Frequency response** 50 Hz – 15 kHz  
**Recording system** AC bias  
**Heads** DECK 1: Playback head x 1  
 DECK 2: Recording/playback head x 1,  
 erase head x 1

### <Compact disc player section>

**Laser** Semiconductor laser (λ =780 nm)  
**D/A converter** 1 bit dual  
**Signal-to-noise ratio** 85 dB (1 kHz, 0 dB)  
**Harmonic distortion** 0.05 % (1 kHz, 0 dB)

### <General>

#### Power requirements

**U:** 120 V AC, 60 Hz  
**HS:** 220 V AC, 60 Hz  
**LH, HA:** 120 V/220 – 230 V/240 V AC  
 Switchable, 50/60 Hz

#### CX-NAJ24 <U>:

**Power consumption** 75 W  
**Power consumption in standby mode** 13 W with power-economizing mode off  
 0.9 W with power-economizing mode on  
**Dimensions (W x H x D)** 260 x 328 x 329 mm  
 (10<sup>1</sup>/<sub>4</sub> x 13 x 13 in.)  
**Weight** 6.4 kg (14 lbs 2 oz.)

#### CX-NBL23/CX-NBL24 <LH>, CX-NBL24E <HA>:

**Power consumption** 80 W  
**Power consumption in standby mode** 13 W with power-economizing mode off  
 0.9 W with power-economizing mode on  
**Dimensions (W x H x D)** 260 x 328 x 329 mm  
**Weight** 6.3 kg

#### CX-NBL34 <LH>, CX-NBL34E <HA>:

**Power consumption** 125 W  
**Power consumption in standby mode** 17 W with power-economizing mode off  
 0.9 W with power-economizing mode on  
**Dimensions (W x H x D)** 260 x 328 x 329 mm  
**Weight** 7.1 kg

#### CX-NBL24 <HS>:

**Power consumption** 70 W  
**Power consumption in standby mode** 13 W with power-economizing mode off  
 0.9 W with power-economizing mode on  
**Dimensions (W x H x D)** 260 x 328 x 329 mm  
**Weight** 6.3 kg

### Speaker system SX-NAJ25 <NSX-AJ24>

### Speaker system SX-NBL25 <NSX-BL23/BL24/BL24E>

### Speaker system SX-NBL42 <NSX-BL34/BL34E>

**Speaker system** 3 way, bass reflex  
 (magnetic shield type)  
**Speaker units** Woofer:  
 140 mm (5<sup>5</sup>/<sub>8</sub> in.) cone type  
 Tweeter:  
 60 mm (2<sup>3</sup>/<sub>8</sub> in.) cone type  
 Super tweeter:  
 20 mm (1<sup>3</sup>/<sub>16</sub> in.) ceramic type

### Impedance

### Sensitivity

### Dimensions (W x H x D)

**SX-NAJ25/SX-NBL25:**

202 x 324 x 219 mm

(8 x 12<sup>7</sup>/<sub>8</sub> x 8<sup>5</sup>/<sub>8</sub> in.)

**SX-NBL42:**

220 x 324 x 230 mm

### Weight

**SX-NAJ25/SX-NBL25:**

3.8 kg (8 lbs 6 oz.)

**SX-NBL42:**

4.0 kg

• Design and specifications are subject to change without notice.

• The word "BBE" and the "BBE symbol" are trademarks of BBE Sound, Inc.  
 Under license from BBE Sound, Inc.

# PROTECTION OF EYES FROM LASER BEAM DURING SERVICING

This set employs laser. Therefore, be sure to follow carefully the instructions below when servicing.

## WARNING!!

WHEN SERVICING, DO NOT APPROACH THE LASER EXIT WITH THE EYE TOO CLOSELY. IN CASE IT IS NECESSARY TO CONFIRM LASER BEAM EMISSION. BE SURE TO OBSERVE FROM A DISTANCE OF MORE THAN 30cm FROM THE SURFACE OF THE OBJECTIVE LENS ON THE OPTICAL PICK-UP BLOCK.

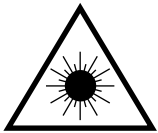

- Caution: Invisible laser radiation when open and interlocks defeated avoid exposure to beam.
- Advarsel: Usynlig laserstråling ved åbning, når sikkerhedsafbrydere er ude af funktion. Undgå udsættelse for stråling.

## VAROITUS!

Laiteen Käyttäminen muulla kuin tässä käyttöohjeessa mainitulla tavalla saattaa altistaa käyt-täjän turvallisuusluokan 1 ylittävälle näkymättömälle lasersäteilylle.

## WARNING!

Om apparaten används på annat sätt än vad som specificeras i denna bruksanvisning, kan användaren utsättas för osynlig laserstråling, som överskrider gränsen för laserklass 1.

## CAUTION

Use of controls or adjustments or performance of procedures other than those specified herein may result in hazardous radiation exposure.

## ATTENTION

L'utilisation de commandes, réglages ou procédures autres que ceux spécifiés peut entraîner une dangereuse exposition aux radiations.

## ADVARSEL

Usynlig laserstråling ved åbning, når sikkerhedsafbrydere er ude af funktion. Undgå udsættelse for stråling.

This Compact Disc player is classified as a CLASS 1 LASER product.

The CLASS 1 LASER PRODUCT label is located on the rear exterior.

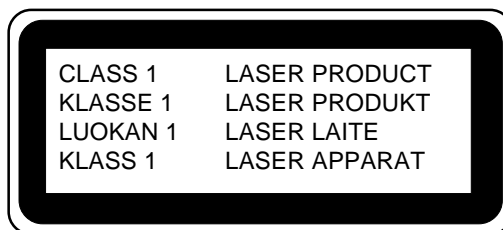

Precaution to replace Optical block

**(KSS – 213F)**

**(KSM – 880CAB)**

Body or clothes electrostatic potential could ruin laser diode in the optical block. Be sure ground body and workbench, and use care the clothes do not touch the diode.

- 1) After the connection, remove solder shown in the right figure.

**(KSS – 213F)**  
PICKUP Assy P.C.B.

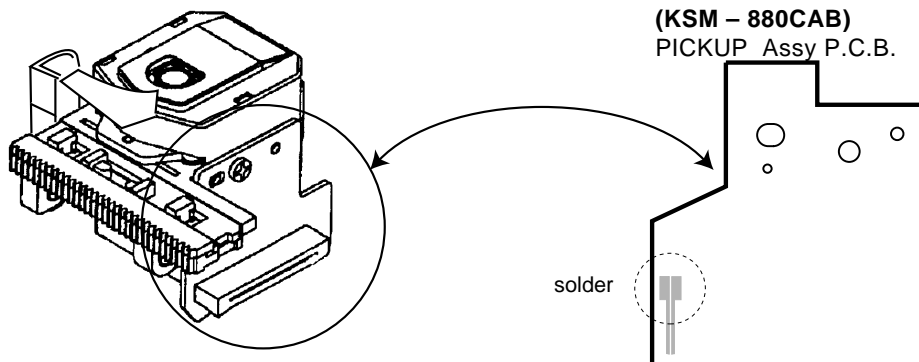
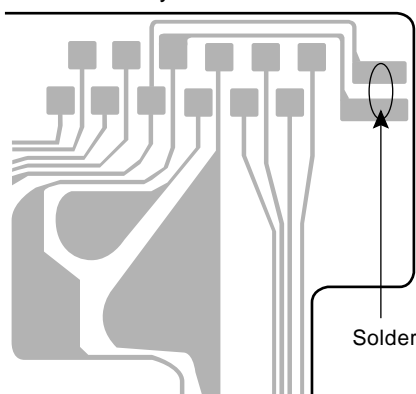

## NOTE ON BEFORE STARTING REPAIR

### 1. Forced discharge of electrolytic capacitor of power supply block

When repair is going to be attempted in the set that uses relay circuit in the power supply block, electric potential is kept charged across the electrolytic capacitors (C101, 102) even though AC power cord is removed. If repair is attempted in this condition, secondary defect can occur.

In order to prevent the secondary trouble, perform the following measures before starting repair work.

#### Discharge procedure

- ① Remove the AC power cord.
- ② Connect a discharging resistor at an end of lead wire that has clips at both ends. Connect the other end of the lead wire to metal chassis.
- ③ Contact the other end of the discharging resistor to the positive (+) side (+VH) of C101. (For two seconds)
- ④ Contact the same end of the discharging resistor as step ③ to the negative (-) side (-VH) of C102 in the same way. (For two seconds)
- ⑤ Check that voltage across C101 and C102 has decreased to 1 V or less using a multimeter or an oscilloscope.

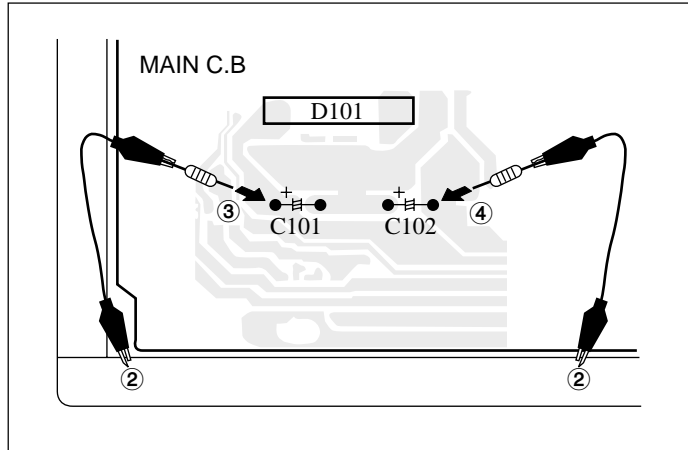

Fig-1

Select a discharging resistor referring to the following table.

Charging voltage (V) (C101, 102)	Discharging resistor ( $\Omega$ )	Rated power (W)	Parts number
25-48	100	3	87-A00-247-090
49-140	220	5	87-A00-232-090

Note: The reference numbers (C101, C102) of the electrolytic capacitors can change depending on the models. Be sure to check the reference numbers of the charging capacitors on schematic diagram before starting the discharging work.

### 2. Check items before exchanging the MICROCOMPUTER

Be sure to check the following items before exchanging the MICROCOMPUTER. Exchange the MICROCOMPUTER after confirming that the MICROCOMPUTER is surely defective.

#### 2-1. Regarding the HOLD terminal of the MICROCOMPUTER

When the HOLD terminal (INPUT) of the MICROCOMPUTER is "H", the MICROCOMPUTER is judged to be operating correctly. When this terminal is "L", the main power cannot be turned on. Therefore, be sure to check the terminal voltage of the HOLD terminal before exchange.

When the MICROCOMPUTER is not defective, the HOLD terminal can also go "L" when the POWER AMPLIFIER has any abnormalities that triggers the abnormality detection circuit on the MAIN C. B. that sets the HOLD terminal to "L".

- Good or no good judgement of the MICROCOMPUTER

- ① Turn on the AC main power.
- ② Confirm that the main power is turned on and the HOLD terminal of the MICROCOMPUTER keeps the "H" level or not.
- ③ When the HOLD terminal is "L" level, the abnormality detection circuit is judged to be working correctly and the MICROCOMPUTER is judged to be good.

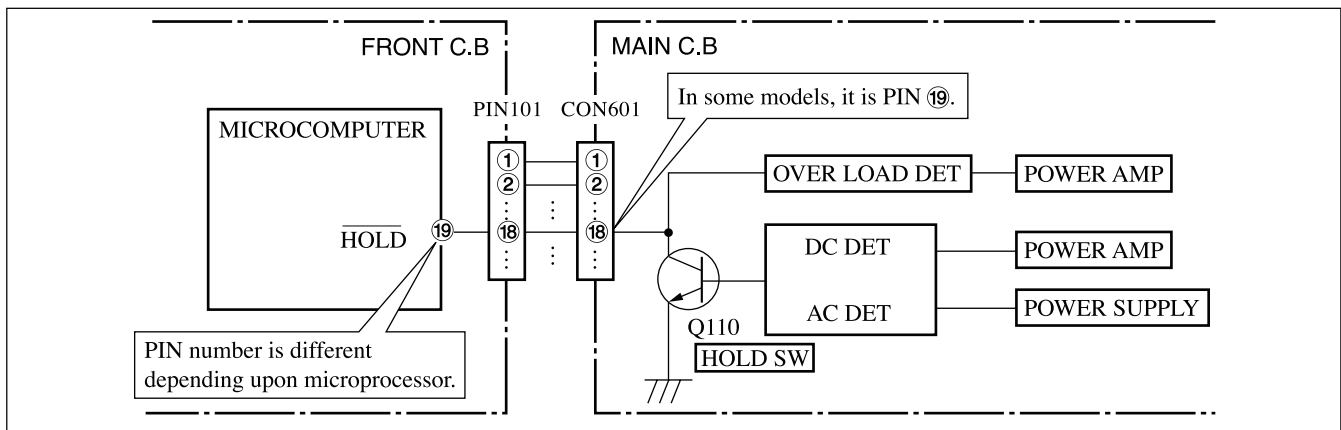

Fig-2-1

In such a case, check also if the POWER AMPLIFIER circuit or power supply circuit has any abnormalities or not.

## 2-2. Regarding reset

There are cases that the machine does not work correctly because the MICROCOMPUTER is not reset even though the AC power cord is re-inserted, or the software reset (pressing the STOP key + POWER key) is performed.

When the above described phenomenon occurs, it can lead to wrong judgement as if the MICROCOMPUTER is defective and to exchange the MICROCOMPUTER. In such a case, perform the forced-reset by the following procedure and check good or no good of the MICROCOMPUTER.

- ① Remove the AC power cord.

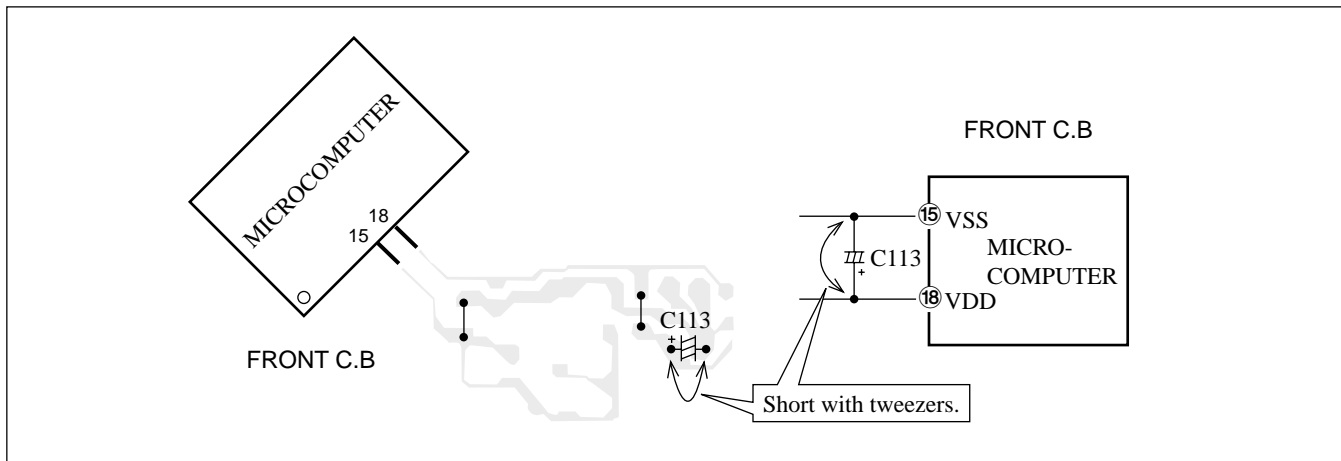

Fig-2-2

- ② Short both ends of the electrolytic capacitor C113 that is connected to VDD of the MICROCOMPUTER with tweezers.
- ③ Connect the AC power cord again. If the MICROCOMPUTER returns to the normal operation, the MICROCOMPUTER is good.

**Note:** The reference number or MICROCOMPUTER pin number of transistor (Q110) and electrolytic capacitor (C113) can change depending on the models. Be sure to check the reference numbers on schematic diagram before starting the discharging work.

## 2-3. Confirmation of soldering state of MICROCOMPUTER

Check the soldering state of the MICROCOMPUTER in addition to the above described procedures. Be sure to exchange the MICROCOMPUTER after surely confirming that the trouble is not caused by poor soldering but the MICROCOMPUTER itself.

# ELECTRICAL MAIN PARTS LIST

REF. NO.	PART NO.	KANRI NO.	DESCRIPTION	REF. NO.	PART NO.	KANRI NO.	DESCRIPTION
<b>IC</b>				C21	87-016-495-000		CAP,E 3300-25 M SMG<24U>
	87-A21-269-010	IC,EW732		C21	87-A12-183-090		CAP,E 3300-25 M 85<24HS>
	87-A21-396-010	IC,STK490-040<24HS>		C21	87-A10-520-000		CAP,E 3300-35 M SMG<23LH,24LH>
	87-A21-398-010	IC,STK490-110<EXCEPT 24HS>		C21	87-A12-182-090		CAP,E 3300-35 M85<24EHA,34LH,34EHA>
	87-A21-419-040	C-IC,NJM14558MD-TE2		C22	87-016-495-000		CAP,E 3300-25 M SMG<24U>
	87-A21-401-040	C-IC,M61503FP		C22	87-A12-183-090		CAP,E 3300-25 M 85<24HS>
	87-A21-415-010	IC,LA1843<24LH,24U>		C22	87-A10-520-000		CAP,E 3300-35 M SMG<23LH,24LH>
	87-A21-560-010	IC,LA1844L-A<EXCEPT 24LH,24U>		C22	87-A12-182-090		CAP,E 3300-35 M85<24EHA,34LH,34EHA>
	8A-NF9-601-110	C-IC,UPD780226GF-014-3BA		C25	87-010-385-080		CAP,ELECT 220-25V
	87-A21-482-010	IC,RPM6938-H4		C26	87-010-247-080		CAP,ELECT 100-50V
	87-070-127-110	IC,LC72131D		C30	87-010-430-080		CAP,ELECT 100-63
<b>TRANSISTOR</b>				C31	87-010-263-080		CAP,ELECT 100-10V
	87-026-609-080	TR,KTA1266GR		C32	87-010-197-080		CAP,CHIP 0.01 DM
	89-213-702-010	TR,2SB1370E		C33	87-010-263-080		CAP,ELECT 100-10V<24U>
	87-026-610-080	TR,KTC3198GR		C34	87-010-247-080		CAP,ELECT 100-50V
	87-A30-076-080	C-TR,2SC3052F		C35	87-010-380-080		CAP,ELECT 47-16V
	87-A30-075-080	C-TR,2SA1235F		C36	87-010-381-080		CAP,ELECT 330-16V
	87-A30-484-080	C-TR,KRA102S<24LH>		C38	87-010-197-080		CAP,CHIP 0.01 DM
	87-A30-074-080	C-TR,RT1P141C<EXCEPT 24LH>		C60	87-010-403-080		CAP,ELECT 3.3-50V
	87-A30-468-080	C-TR,KRC102S-RTK		C61	87-010-260-080		CAP,ELECT 47-25V
	87-A30-107-070	C-TR,CMBT5401		C97	87-010-196-080		CHIP CAPACITOR,0.1-25
	87-A30-106-040	C-TR,CMBT5551		C101	87-010-185-080		C-CAP,S 3900P-50 B
	87-026-235-080	C-TR,DTC114EK<24U>		C102	87-010-185-080		C-CAP,S 3900P-50 B
	87-026-245-080	TR,DTC114ES<EXCEPT 24U>		C103	87-010-545-080		CAP,ELECT 0.22-50V
	87-A30-087-080	C-FET,2SK2158		C104	87-010-545-080		CAP,ELECT 0.22-50V
	87-A30-091-080	FET,2SJ460		C105	87-010-187-080		CAP,CHIP S5600P
	87-A30-090-080	FET,2SK2541		C106	87-010-187-080		CAP,CHIP S5600P
	87-A30-062-080	C-TR,KRC104S		C107	87-010-404-080		CAP,ELECT 4.7-50V
	87-A30-318-080	TR,CSA952K		C108	87-010-404-080		CAP,ELECT 4.7-50V
	89-333-317-880	TR,2SC3331(T/U)		C109	87-010-179-080		C-CAP,S 1200P-50K<23LH,24EHA,34EHA>
	87-A30-329-080	TR,CD1585BC		C110	87-010-179-080		C-CAP,S 1200P-50K<23LH,24EHA,34EHA>
	89-327-143-080	C-TR,2SC27140<EXCEPT 24LH,24U>		C111	87-010-391-080		CAP,E 10-35 SME
	87-A30-072-080	C-TR,RT1P144C		C112	87-010-391-080		CAP,E 10-35 SME
	87-A30-234-080	TR,CSC4115BC		C113	87-010-405-080		CAP,E 10-50<23LH,24LH,24HS,24EHA>
	87-A30-198-080	TR,KTC3199GR<EXCEPT 24U>		C113	87-010-866-080		CAP,E 10-63 M VX<24U,34LH,34EHA>
<b>DIODE</b>				C114	87-010-405-080		CAP,E 10-50<23LH,24LH,24HS,24EHA>
	87-A40-736-080	DIODE,1N4148M(SEM)<24LH>		C114	87-010-866-080		CAP,E 10-63 M VX<24U,34LH,34EHA>
	87-A40-393-090	DIODE,1N5402 GW(F20)<24U>		C119	87-012-369-080		C-CAP,S 0.047-50 ZF<24U>
	87-020-465-080	DIODE,1SS133<EXCEPT 24LH>		C119	87-010-197-080		CAP,CHIP 0.01<23LH,24LH,24HS,24EHA>
	87-A40-455-090	DIODE,RL203 GW<EXCEPT 24HS>		C119	87-016-369-080		C-CAP,S 0.033-25 KB GRM<34LH,34EHA>
	87-A40-535-080	DIODE,1N5393<EXCEPT 24U,34LH,34EHA>		C120	87-012-369-080		C-CAP,S 0.047-50 ZF<24U>
	87-A40-553-080	DIODE,1N4003 LES		C120	87-010-197-080		CAP,CHIP 0.01<23LH,24LH,24HS,24EHA>
	87-A40-776-080	ZENER,UZ27BSD		C120	87-016-369-080		C-CAP,S 0.033-25 KB GRM<34LH,34EHA>
	87-A40-764-080	ZENER,UZ10BSC		C125	87-012-368-080		C-CAP,S 0.1-50 F
	87-A40-313-080	C-DIODE,MC2840		C126	87-012-368-080		C-CAP,S 0.1-50 F
	87-A40-270-080	C-DIODE,MC2838		C127	87-012-368-080		C-CAP,S 0.1-50 F
	87-A40-269-080	C-DIODE,MC2836		C128	87-012-368-080		C-CAP,S 0.1-50 F
	87-A40-854-080	ZENER,UZ15BSA		C129	87-010-191-080		C-CAP,S 0.015-50 F
	87-A40-752-080	ZENER,UZ6.2BSC		C130	87-010-191-080		C-CAP,S 0.015-50 F
	87-A40-739-080	ZENER,UZ2.7BSA		C131	87-010-197-080		CAP,CHIP 0.01 DM
	87-017-149-080	ZENER,HZS6A2L		C132	87-010-197-080		CAP,CHIP 0.01 DM
				C133	87-010-186-080		CAP,CHIP 4700P
				C140	87-010-182-080		C-CAP,S 2200P-50 B
				C141	87-010-196-080		CHIP CAPACITOR,0.1-25
				C235	87-010-408-080		CAP,ELECT 47-50V<24U>
<b>MAIN C.B</b>				C236	87-010-408-080		CAP,ELECT 47-50V<24U>
				C239	87-010-196-080		CHIP CAPACITOR,0.1-25
				C301	87-010-178-080		CHIP CAP,1000P
C3	87-012-368-080	C-CAP,S 0.1-50 F		C302	87-010-178-080		CHIP CAP,1000P
C4	87-012-368-080	C-CAP,S 0.1-50 F		C303	87-010-178-080		CHIP CAP,1000P
C5	87-012-368-080	C-CAP,S 0.1-50 F		C304	87-010-178-080		CHIP CAP,1000P
C6	87-012-368-080	C-CAP,S 0.1-50 F		C305	87-010-198-080		C-CAP,S 0.022-25 KB<34LH,34EHA>
C9	87-012-368-080	C-CAP,S 0.1-50 F		C307	87-010-263-080		CAP,ELECT 100-10V
C10	87-012-368-080	C-CAP,S 0.1-50 F		C308	87-010-263-080		CAP,ELECT 100-10V
C11	87-012-368-080	C-CAP,S 0.1-50 F		C309	87-010-318-080		C-CAP,S 47P-50 CH
C12	87-012-368-080	C-CAP,S 0.1-50 F		C310	87-010-318-080		C-CAP,S 47P-50 CH
C19	87-A12-193-090	CAP,E 2200-50 M 85 SAMXON<24HS>		C313	87-010-188-080		CAP,CHIP 6800P
C19	87-A12-036-000	CAP,E 2200-63 M SMG<EXCEPT 24HS>		C314	87-010-188-080		CAP,CHIP 6800P
C20	87-A12-193-090	CAP,E 2200-50 M 85 SAMXON<24HS>		C315	87-010-263-080		CAP,ELECT 100-10V
C20	87-A12-036-000	CAP,E 2200-63 M SMG<EXCEPT 24HS>		C317	87-010-546-080		CAP,ELECT 0.33-50V

REF. NO.	PART NO.	KANRI NO.	DESCRIPTION	REF. NO.	PART NO.	KANRI NO.	DESCRIPTION
C318	87-010-546-080		CAP,ELECT 0.33-50V	C800	87-012-369-080		C-CAP,S 0.047-50F
C326	87-010-198-080		CAP,CHIP 0.022	C801	87-010-403-080		CAP,ELECT 3.3-50V
C327	87-012-368-080		C-CAP,S 0.1-50 F	C802	87-010-194-080		CAP,CHIP 0.047
C360	87-010-401-080		CAP,ELECT 1-50V	C803	87-010-198-080		CAP,CHIP 0.022
C399	87-012-140-080		CAP,470P	C804	87-010-263-080		CAP,ELECT 100-10V
C401	87-010-544-080		CAP,ELECT 0.1-50V	C807	87-010-400-080		CAP,ELECT 0.47-50V
C402	87-010-544-080		CAP,ELECT 0.1-50V	C808	87-010-401-080		CAP,ELECT 1-50V
C403	87-010-321-080		CHIP CAPACITOR,82P(J)	C809	87-010-401-080		CAP,ELECT 1-50V
C404	87-010-321-080		CHIP CAPACITOR,82P(J)	C810	87-010-196-080		CHIP CAPACITOR,0.1-25
C405	87-010-197-080		CAP,CHIP 0.01 DM	C814	87-010-197-080		CAP,CHIP 0.01 DM
C406	87-010-197-080		CAP,CHIP 0.01 DM	C815	87-010-400-080		CAP,ELECT 0.47-50V
C407	87-010-197-080		CAP,CHIP 0.01 DM	C816	87-010-400-080		CAP,ELECT 0.47-50V
C408	87-010-197-080		CAP,CHIP 0.01 DM	C821	87-010-405-080		CAP,ELECT 10-50V
C409	87-010-182-080		C-CAP,S 2200P-50 B	C823	87-010-177-080		C-CAP,S 820P-50 J SL
C410	87-010-182-080		C-CAP,S 2200P-50 B	C824	87-010-405-080		CAP,ELECT 10-50V
C411	87-010-405-080		CAP,ELECT 10-50V	C825	87-010-596-080		CAP,S 0.047-16
C412	87-010-405-080		CAP,ELECT 10-50V	C842	87-010-197-080		CAP,CHIP 0.01 DM
C452	87-010-382-080		CAP,ELECT 22-25V	C844	87-010-197-080		CAP,CHIP 0.01 DM
C453	87-010-183-080		C-CAP,S 2700P-50 B	C850	87-010-260-080		CAP,ELECT 47-25V
C454	87-010-183-080		C-CAP,S 2700P-50 B	C851	87-010-197-080		CAP,CHIP 0.01 DM
C455	87-010-183-080		C-CAP,S 2700P-50 B	C852	87-010-197-080		CAP,CHIP 0.01 DM
C456	87-010-197-080		CAP,CHIP 0.01 DM	C853	87-010-197-080		CAP,CHIP 0.01 DM
C460	87-010-196-080		CHIP CAPACITOR,0.1-25	C858	87-010-196-080		CHIP CAPACITOR,0.1-25
C461	87-012-158-080		C-CAP,S 390P-50 CH	C859	87-010-196-080		CHIP CAPACITOR,0.1-25
C462	87-012-158-080		C-CAP,S 390P-50 CH	C860	87-010-197-080		CAP,CHIP 0.01 DM
C605	87-010-184-080		C-CAP,S 3300P-50 KB<24U,34LH,34EHA>	C959	87-010-196-080		CHIP CAPACITOR,0.1-25
C605	87-010-179-080		C-CAP,S 1200P<23LH,24LH,24HS,24EHA>	C960	87-010-196-080		CHIP CAPACITOR,0.1-25
C606	87-010-184-080		C-CAP,S 3300P-50 KB<24U,34LH,34EHA>	C961	87-010-152-080		C-CAP,S 8P-50 D CH GRM
C606	87-010-179-080		C-CAP,S 1200P<23LH,24LH,24HS,24EHA>	C963	87-015-785-080		CHIP CAPACITOR,0.1FZ-25Z
C609	87-010-213-080		C-CAP,S 0.015-25 B	C971	87-010-381-080		CAP,ELECT 330-16V
C610	87-010-213-080		C-CAP,S 0.015-25 B	C972	87-010-404-080		CAP,ELECT 4.7-50V
C611	87-010-545-080		CAP,ELECT 0.22-50V	C973	87-010-197-080		CAP,CHIP 0.01 DM
C612	87-010-545-080		CAP,ELECT 0.22-50V	C974	87-010-197-080		CAP,CHIP 0.01 DM
C613	87-010-545-080		CAP,ELECT 0.22-50V	C979	87-010-322-080		C-CAP,S 100P-50 CH
C614	87-010-545-080		CAP,ELECT 0.22-50V	C981	87-010-260-080		CAP,ELECT 47-25V
C615	87-010-154-080		CAP,CHIP 10P	C982	87-010-196-080		CHIP CAPACITOR,0.1-25
C616	87-010-221-080		CAP,ELECT 470-10V	C983	87-010-197-080		CAP,CHIP 0.01 DM
C617	87-010-221-080		CAP,ELECT 470-10V	C984	87-010-197-080		CAP,CHIP 0.01 DM
C618	87-010-405-080		CAP,ELECT 10-50V	C987	87-010-197-080		CAP,CHIP 0.01 DM
C630	87-016-669-080		C-CAP,S 0.1-25 K B	C991	87-010-312-080		C-CAP,S 15P-50 CH
C631	87-010-185-080		C-CAP,S 3900P-50 B	C992	87-010-312-080		C-CAP,S 15P-50 CH
C632	87-010-185-080		C-CAP,S 3900P-50 B	C993	87-010-178-080		CHIP CAP,1000P
C633	87-016-369-080		C-CAP,S 0.033-25 B K	C995	87-010-178-080		CHIP CAP,1000P
C634	87-016-369-080		C-CAP,S 0.033-25 B K	C997	87-010-196-080		CHIP CAPACITOR,0.1-25
C669	87-010-322-080		C-CAP,S 100P-50 CH	C998	87-010-260-080		CAP,ELECT 47-25V
C670	87-010-322-080		C-CAP,S 100P-50 CH	C999	87-A11-155-080		CAP,TC U 0.01-16 Z F
C671	87-010-196-080		CHIP CAPACITOR,0.1-25<24HS>	CF831	87-008-261-010		FLTR,CF SFE10.7MA5
C672	87-010-196-080		CHIP CAPACITOR,0.1-25<24HS>	CF832	87-008-261-010		FLTR,CF SFE10.7MA5
C673	87-010-182-080		C-CAP,S 2200P-50KB<24HS>	CN301	87-A60-620-010		CONN,3P V 2MM JMT
C677	87-010-197-080		CAP,CHIP 0.01 DM	CN351	87-A60-625-010		CONN,8P V 2MM JMT
C771	87-010-263-080		CAP,ELECT 100-10V	CN601	87-099-719-010		CONN,30P TYK-B(X)
C772	87-010-197-080		CAP,CHIP 0.01 DM	CN602	87-A60-131-010		CONN,6P V FE
C782	87-010-197-080		CAP,CHIP 0.01 DM	CNA1	8A-NF8-653-010		CONN ASSY,9P TID-A(480)<EXCEPT 24U>
C783	87-010-197-080		CAP,CHIP 0.01 DM	FFC602	88-906-251-110		FF-CABLE,6P 1.25
C784	87-010-197-080		CAP,CHIP 0.01 DM	FFE831	A8-8ZA-191-030		8ZA-1 YFEUNM<23LH>
C785	87-010-197-080		CAP,CHIP 0.01 DM	FFE831	A8-8ZA-193-070		8ZA-1 YFEUNC<EXCEPT 23LH>
C786	87-010-197-080		CAP,CHIP 0.01 DM	J202	87-A60-488-010		JACK,DIA6.3 BLK ST W/SW KM16AT
C788	87-010-149-080		C-CAP,S 5P-50 CH	J203	87-A60-238-010		TERMINAL,SP 4P (MSC)
C789	87-A10-801-080		C-CAP,S 0.022-16 JB CM<24HS>	J205	87-A60-881-010		JACK,PIN 2P MSP 242V05 PBSN<24U>
C789	87-A12-052-080		C-CAP,S 0.033-25 JB<EXCEPT 24HS>	J602	87-A60-881-010		JACK,PIN 2P MSP 242V05 PBSN
C790	87-A10-801-080		C-CAP,S 0.022-16 JB CM<24HS>	J831	87-A60-202-010		TERMINAL,ANT 4P MSP-154V-02
C790	87-A12-052-080		C-CAP,S 0.033-25 JB<EXCEPT 24HS>	L101	87-A50-610-010		COIL,1UH K(MDEC)
C791	87-010-196-080		CHIP CAPACITOR,0.1-25	L102	87-A50-610-010		COIL,1UH K(MDEC)
C792	87-010-197-080		CAP,CHIP 0.01 DM	L451	87-007-342-010		COIL,OSC 85K BIAS
C793	87-010-404-080		CAP,ELECT 4.7-50V	L801	87-A50-540-010		COIL,FM DET(TOK)<24U,24LH>
C795	87-010-197-080		CAP,CHIP 0.01 DM	L801	87-A50-608-010		COIL,FM DET-N(TOK)<EXCEPT 24U,24LH>
C796	87-010-197-080		CAP,CHIP 0.01 DM	L802	87-A91-551-010		FLTR,PCFJZH-450 L(TOK)
C797	87-010-405-080		CAP,ELECT 10-50V	L811	87-005-847-080		COIL,2.2UH(CECS)
C798	87-010-197-080		CAP,CHIP 0.01 DM	L832	87-005-847-080		COIL,2.2UH(CECS)
C799	87-010-407-080		CAP,ELECT 33-50V	L951	8A-NF8-667-010		COIL,AM PACK 4(TOK)



REF. NO.	PART NO.	KANRI NO.	DESCRIPTION	REF. NO.	PART NO.	KANRI NO.	DESCRIPTION
R129	87-A00-669-080		RES,M/F 0.22-2W JRA<24U,34LH,34EHA>	C913	87-010-248-040		CAP,E 220-10 SME
R130	87-A00-669-080		RES,M/F 0.22-2W JRA<24U,34LH,34EHA>	C914	87-010-248-040		CAP,E 220-10 SME
R131	87-A00-669-080		RES,M/F 0.22-2W JRA<24U,34LH,34EHA>	C915	87-010-196-080		CHIP CAPACITOR,0.1-25
R131	87-A00-257-080		RES,M/F 0.15-1W J<23LH,24LH,24EHA>	C916	87-010-196-080		CHIP CAPACITOR,0.1-25
R131	87-A00-258-080		RES,M/F 0.22-1W J<24HS>	C917	87-010-196-080		CHIP CAPACITOR,0.1-25
R132	87-A00-669-080		RES,M/F 0.22-2W JRA<24U,34LH,34EHA>	C919	87-010-197-080		CAP,CHIP 0.01 DM
R132	87-A00-257-080		RES,M/F 0.22-1W J<23LH,24LH,24EHA>	C920	87-012-369-080		C-CAP,S 0.047-50F
R132	87-A00-258-080		RES,M/F 0.22-1W J<24HS>	C921	87-010-186-080		CAP,CHIP 4700P
R143	87-A00-440-050		RES,220-1/2W J RP	C951	87-010-312-080		C-CAP,S 15P-50 CH
R144	87-A00-440-050		RES,220-1/2W J RP	C952	87-012-155-080		C-CAP,180P-50CH
R145	87-A00-440-050		RES,220-1/2W J RP	C953	87-012-140-080		CAP,470P
R146	87-A00-440-050		RES,220-1/2W J RP	C961	87-010-378-040		CAP,E 10-16
R653	87-A11-144-080		CAP,TC U 0.1-50 K B	C962	87-012-157-080		C-CAP,S 330P-50 CH
R654	87-A11-144-080		CAP,TC U 0.1-50 K B	C963	87-010-196-080		CHIP CAPACITOR,0.1-25
R790	87-010-197-080		CAP,CHIP 0.01 DM	CN104	87-A60-057-010		CONN,11P V 9604S-11C
R991	87-010-322-080		C-CAP,S 100P-50 CH	CN701	87-099-720-010		CONN,30P TYK-B(P)
R993	87-010-322-080		C-CAP,S 100P-50 CH	CN731	87-099-015-010		CONN,13P 6216V
R995	87-010-322-080		C-CAP,S 100P-50 CH	EMI401	87-008-372-080		FLTR,EMIBL01RN1<24HS>
SFR451	87-A90-432-080		SFR,30K H NVZ6TLTA	FFC104	88-911-101-110		FF-CABLE,11P 1.25
SFR452	87-A90-432-080		SFR,30K H NVZ6TLTA	FFC731	88-913-301-110		FF-CABLE,13P 1.25
W99	8A-NF9-609-010		F-CABLE,9P 2.5 480MM<24U>	FL901	8A-NF9-605-010		FL,HNA-10SS12
WH1	87-A90-510-010		HLDR,WIRE 2.5-9P	J401	87-A61-242-010		JACK 6.3 BLK MONO W/SW VKM<24HS>
X991	87-A70-061-010		VIB,XTAL 4.500MHZ CSA-309	L951	87-A50-434-010		COIL,CLK 4.19M(TOKO)
				LED201	87-A40-619-040		LED,SLR-56PT-T31-W GRN
				LED202	87-A40-619-040		LED,SLR-56PT-T31-W GRN
FRONT C.B				LED204	87-A40-619-040		LED,SLR-56PT-T31-W GRN
C101	87-010-196-080		CHIP CAPACITOR,0.1-25	LED205	87-A40-619-040		LED,SLR-56PT-T31-W GRN
C102	87-010-196-080		CHIP CAPACITOR,0.1-25	LED209	87-A40-317-080		LED,SLR-342VCT31 RED
C103	87-010-498-040		CAP,E 10-16 GAS	LED210	87-A40-619-040		LED,SLR-56PT-T31-W GRN
C104	87-010-196-080		CHIP CAPACITOR,0.1-25	S301	87-A90-164-080		SW,TACT SKQNB(N)
C107	87-010-493-040		CAP,E 0.47-50 GAS	S302	87-A90-164-080		SW,TACT SKQNB(N)
C108	87-012-393-080		C-CAP,S 0.22-16 R K	S303	87-A90-164-080		SW,TACT SKQNB(N)
C153	87-010-198-080		CAP,CHIP 0.022	S304	87-A90-164-080		SW,TACT SKQNB(N)
C154	87-010-246-040		CAP,E 47-35 SME	S305	87-A90-164-080		SW,TACT SKQNB(N)
C155	87-010-404-040		CAP,E 4.7-50 SME	S306	87-A90-164-080		SW,TACT SKQNB(N)
C156	87-010-404-040		CAP,E 4.7-50 SME	S307	87-A90-164-080		SW,TACT SKQNB(N)
C361	87-010-178-080		CHIP CAP,1000P	S308	87-A90-164-080		SW,TACT SKQNB(N)
C362	87-010-178-080		CHIP CAP,1000P	S309	87-A90-164-080		SW,TACT SKQNB(N)
C371	87-010-178-080		CHIP CAP,1000P	S321	87-A90-164-080		SW,TACT SKQNB(N)
C372	87-010-178-080		CHIP CAP,1000P	S322	87-A90-164-080		SW,TACT SKQNB(N)
C401	87-010-186-080		C-CAP,S 4700P-50 KB<24HS>	S323	87-A90-164-080		SW,TACT SKQNB(N)
C402	87-010-112-040		CAP,E 100-16 M 11L SME<24HS>	S324	87-A90-164-080		SW,TACT SKQNB(N)
C403	87-010-545-040		CAP,E 0.22-50 M 11L SME<24HS>	S325	87-A90-164-080		SW,TACT SKQNB(N)
C404	87-010-320-080		C-CAP,S 68P-50 J CH GRM<24HS>	S326	87-A90-164-080		SW,TACT SKQNB(N)
C405	87-010-544-040		CAP,E 0.1-50 M 11L SME<24HS>	S341	87-A90-164-080		SW,TACT SKQNB(N)
C406	87-010-544-040		CAP,E 0.1-50 M 11L SME<24HS>	S342	87-A90-164-080		SW,TACT SKQNB(N)
C407	87-010-405-040		CAP,E 10-50 M 11L SME<24HS>	S343	87-A90-164-080		SW,TACT SKQNB(N)
C408	87-010-322-080		C-CAP,S 100P-50 J CH GRM<24HS>	S344	87-A90-164-080		SW,TACT SKQNB(N)
C409	87-010-265-040		CAP,E 33-16 M 11L SME<24HS>	S345	87-A90-164-080		SW,TACT SKQNB(N)
C410	87-012-369-080		C-CAP,S 0.047-50 ZF<24HS>	S346	87-A90-164-080		SW,TACT SKQNB(N)
C413	87-010-177-080		C-CAP,S 820P-50 J SL<24HS>	S347	87-A90-164-080		SW,TACT SKQNB(N)
C601	87-010-382-040		CAP,E 22-25 SME	S348	87-A90-164-080		SW,TACT SKQNB(N)
C801	87-010-195-080		C-CAP,S 0.068-25 F	S349	87-A90-164-080		SW,TACT SKQNB(N)
C802	87-010-195-080		C-CAP,S 0.068-25 F	S350	87-A90-164-080		SW,TACT SKQNB(N)
C803	87-010-402-040		CAP,E 2.2-50 SME	S361	87-A91-633-010		SW,RTRY XRE012103PVB25FINA 1-2
C804	87-010-402-040		CAP,E 2.2-50 SME	S371	87-A91-632-010		SW,RTRY XRE012103PVB25FINB 1-2
C805	87-010-196-080		CHIP CAPACITOR,0.1-25	VR401	87-NB7-602-010		VR,RTRY 10KAX1 1V<24HS>
C806	87-010-196-080		CHIP CAPACITOR,0.1-25				
C901	87-010-322-080		C-CAP,S 100P-50 CH				
C902	87-010-322-080		C-CAP,S 100P-50 CH				
C903	87-010-322-080		C-CAP,S 100P-50 CH				
C904	87-010-322-080		C-CAP,S 100P-50 CH				
C905	87-010-322-080		C-CAP,S 100P-50 CH				
C906	87-010-322-080		C-CAP,S 100P-50 CH				
C907	87-010-322-080		C-CAP,S 100P-50 CH				
C908	87-010-322-080		C-CAP,S 100P-50 CH				
C909	87-010-322-080		C-CAP,S 100P-50 CH				
C910	87-010-322-080		C-CAP,S 100P-50 CH				
C911	87-010-178-080		CHIP CAP,1000P				
C912	87-010-196-080		CHIP CAPACITOR,0.1-25				
				PT C.B <24U ONLY>			
				C183	87-010-387-080		CAP,E 470-25 SME
				C184	87-010-403-080		CAP,ELECT 3.3-50V
				△ PT1	8A-NF9-612-010		PT,ANF-9 U
				△ PT181	8A-NF8-661-010		PT,SUB ANF-8(U)
				△ RY181	87-A91-418-010		RELAY,AC12V G5PA-1-M
				△ T181	87-A60-317-010		TERMINAL,1P MSC
				△ T182	87-A60-317-010		TERMINAL,1P MSC
				WH181	87-A90-510-010		HLDR,WIRE 2.5-9P

REF. NO.	PART NO.	KANRI NO.	DESCRIPTION
PT C.B <EXCEPT 24U>			
C1	87-010-387-080		CAP,E 470-25 M SME
C31	87-010-403-080		CAP,E 3.3-50 M 11L SME
CN1	87-A61-110-010		CPNN,9P V TID-A
△PT1	8A-NF9-614-010		PT,ANF-9 HR-HI<23LH,24LH,24EHA>
△PT1	8A-NF9-613-010		PT,ANF-9 HR<24HS>
△PT1	8A-NF9-616-010		PT,ANF-9 LH-H<34LH,34EHA>
△PT2	8A-NF8-673-010		PT,SUB ANF-8(H)KAMI
△RY1	87-A91-339-010		RELAY,AC DC12V GSPA-2
△S1	87-A90-165-010		SW,SL 1-2-3 SWS2301<23LH,24LH,24EHA,34LH,34EHA>
△T1	87-A60-317-010		TERMINAL,1P MSC
△T2	87-A60-317-010		TERMINAL,1P MSC

DECK C.B

CN1	87-099-753-010	CONN,11P H 9604
SFR1	87-024-581-010	SFR,3.3K H KVSF637A
SOL1	82-ZM3-627-010	SOL ASSY,27 S0
SOL2	82-ZM3-627-010	SOL ASSY,27 S0
SW1	87-A90-673-010	SW,MICRO ESE11SH1C
SW2	87-A91-500-010	SW,MICRO MPU11470MLB0
SW3	87-A91-500-010	SW,MICRO MPU11470MLB0
SW4	87-A91-500-010	SW,MICRO MPU11470MLB0
SW5	87-A90-673-010	SW,MICRO ESE11SH1C
W1	82-ZM3-601-010	RBN-CORD,4P-75

○チップ抵抗部品コード/CHIP RESISTOR PART CODE

チップ抵抗部品コードの成り立ち

Chip Resistor Part Coding

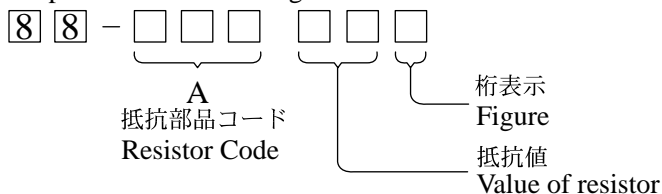

チップ抵抗  
Chip resistor

容量 Wattage	種類 Type	許容誤差 Tolerance	記号 Symbol	寸法/Dimensions (mm)			抵抗コード : A Resistor Code : A	
				外形/Form	L	W		t
1/16W	1005	± 5%	CJ		1.0	0.5	0.35	104
1/16W	1608	± 5%	CJ		1.6	0.8	0.45	108
1/10W	2125	± 5%	CJ		2	1.25	0.45	118
1/8W	3216	± 5%	CJ		3.2	1.6	0.55	128

# TRANSISTOR ILLUSTRATION

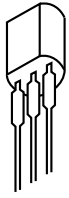

E C B

CD1585  
CSA952  
CSC4115  
KTA1266  
KTC3198



E C B

DTC114ES  
KTC3199



E C B

2SC3331

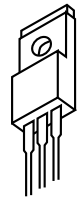

B C E

2SB1370

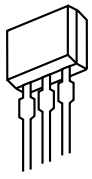

S D G

2SJ460  
2SK2541

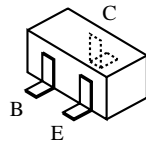

B  
E

2SA1235  
2SC2714  
2SC3052  
CMBT5401  
CMBT5551  
DTC114EK  
KRA102S  
KRC102S  
KRC104S  
RT1P141C  
RT1P144C

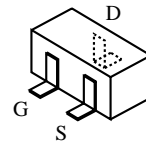

G  
S

2SK2158

# FL (HNA-10SS12) GRID ASSIGNMENT / ANODE CONNECTION / PIN CONNECTION

## GRID ASSIGNMENT

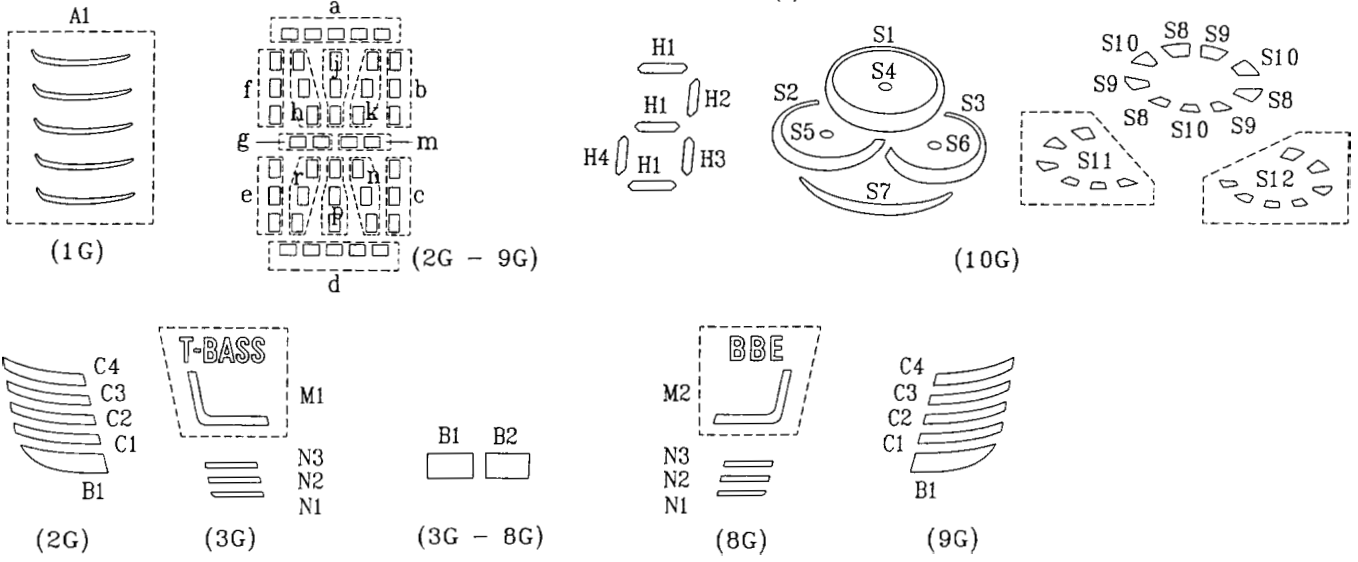
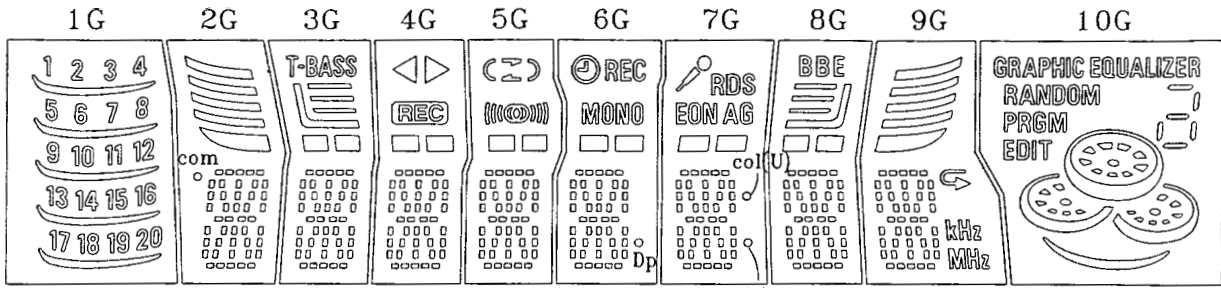

## ANODE CONNECTION

	1G	2G	3G	4G	5G	6G	7G	8G	9G	10G
P1	20	d	d	d	d	d	d	d	d	S1
P2	19	n	n	n	n	n	n	n	n	S2
P3	18	p	p	p	p	p	p	p	p	S3
P4	17	r	r	r	r	r	r	r	r	S4
P5	16	e	e	e	e	e	e	e	e	S5
P6	15	c	c	c	c	c	c	c	c	S6
P7	14	g	g	g	g	g	g	g	g	S7
P8	13	m	m	m	m	m	m	m	m	S8
P9	12	f	f	f	f	f	f	f	f	S9
P10	11	b	b	b	b	b	b	b	b	S10
P11	10	k	k	k	k	k	k	k	k	S11
P12	9	j	j	j	j	j	j	j	j	S12
P13	8	h	h	h	h	h	h	h	h	EDIT
P14	7	a	a	a	a	a	a	a	a	PRGM
P15	6	B1	B1	B1	B1	B1	B1	B1	B1	RANDOM
P16	5	C1	B2	B2	B2	B2	B2	B2	C1	GRAPHIC EQUALIZER
P17	4	C2	M1	REC	MONO	Dp	col(U)	M2	C2	H1
P18	3	C3	N1	<	C	MONO	col(L)	N1	C3	H2
P19	2	C4	N2	>	N	REC	EON	N2	C4	H3
P20	1	com	N3	/	)	Ⓢ	AG	N3	↺	H4
P21	A1	/	/	/	/	/	RDS	/	kHz	/
P22	/	/	/	/	/	/	/	/	MHz	/

## PIN CONNECTION

PIN NO.	45	44	43	42	41	40	39	38	37	36	35	34	33	32	31	30	29	28	27	26	25	24	23	22	21	20	19	18	17	16	15	14	13	12	11
CONNECTION	F2	F2	NP	NP	P1	P2	P3	P4	P5	P6	P7	P8	P9	P10	P11	P12	P13	P14	P15	P16	P17	P18	P19	P20	P21	P22	NC	NC	NC	NC	NC	1G	2G	3G	4G

© Notes ©

- 1) Fn : Filament pin
- 2) nG : Grid pin
- 3) Pn : Anode pin
- 4) NC : No Connected pin
- 5) NP : No pin

10	9	8	7	6	5	4	3	2	1
5G	6G	7G	8G	9G	10G	NP	NP	F1	F1

32 31 30 29 28 27 26 25 24 23 22 21 20 19 18 17 16 15 14 13 12 11 10 9 8 7 6 5 4 3 2 1

A  
B  
C  
D  
E  
F  
G  
H  
I  
J  
K  
L  
M  
N  
O  
P  
Q  
R  
S  
T  
U

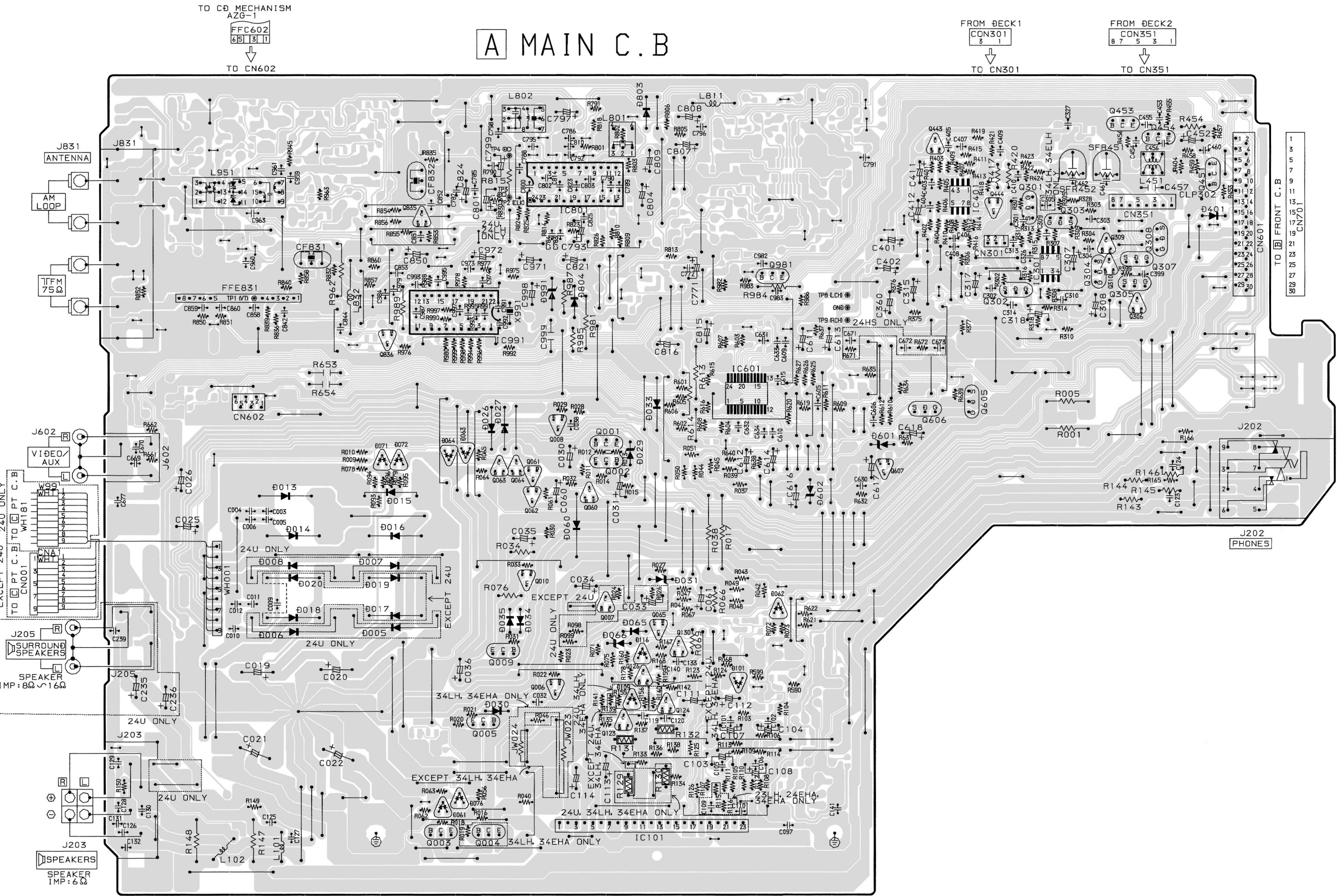

SCHEMATIC DIAGRAM - 1 (MAIN : 1/2 <AMP SECTION>)

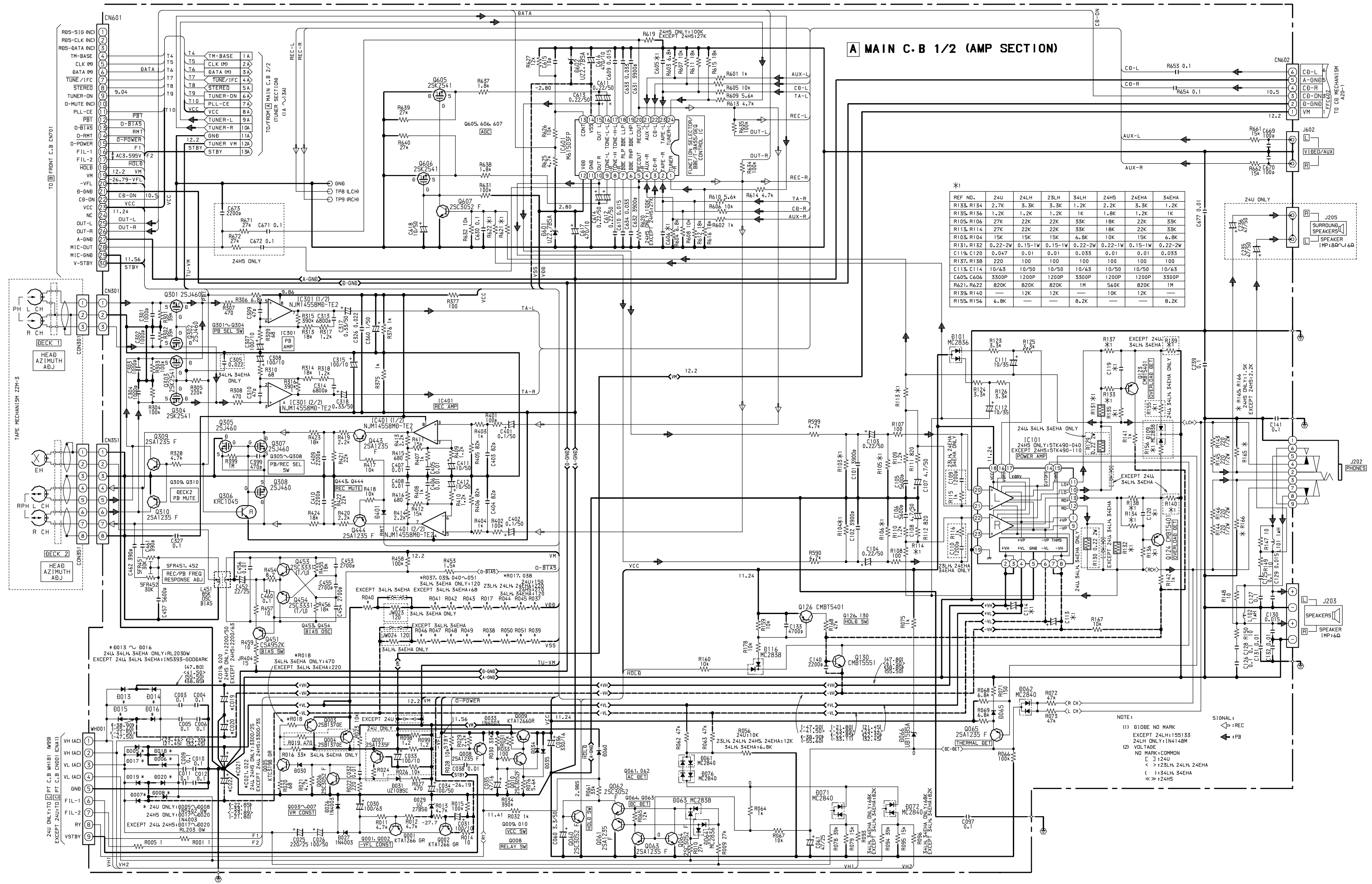

\*1

REF NO.	24U	24LH	23LH	34LH	24HS	24EHA	34EHA
R133, R134	2.7K	3.3K	3.3K	1.2K	2.2K	3.3K	1.2K
R135, R136	1.2K	1.2K	1.2K	1K	1.8K	1.2K	1K
R105, R106	27K	22K	22K	35K	18K	22K	35K
R113, R114	27K	22K	22K	35K	18K	22K	35K
R103, R104	15K	15K	15K	6.8K	10K	15K	6.8K
R131, R132	0.22-2W	0.15-1W	0.15-1W	0.22-2W	0.22-1W	0.15-1W	0.22-2W
C119, C120	0.047	0.01	0.01	0.033	0.01	0.01	0.033
R137, R138	220	100	100	100	100	100	100
C113, C114	10/63	10/50	10/50	10/63	10/50	10/50	10/63
C605, C606	3300P	1200P	1200P	3300P	1200P	1200P	3300P
R621, R622	820K	820K	1M	560K	820K	1M	820K
R139, R140	12K	12K	12K	10K	12K	12K	12K
R155, R156	6.8K	—	—	8.2K	—	—	8.2K

NOTE:  
 (1) 010E NO MARK  
 EXCEPT 24LH:1S9133  
 24LH ONLY:1N4148M  
 (2) VOLTAGE  
 NO MARK:COMMON  
 C : 24U  
 < : 23LH, 24LH, 24EHA  
 < : 34LH, 34EHA  
 <> : 24HS



32 31 30 29 28 27 26 25 24 23 22 21 20 19 18 17 16 15 14 13 12 11 10 9 8 7 6 5 4 3 2 1

# B FRONT C.B

IC961 (REMOTE SENSOR)

S308 BBE

S309 T-BASS

FL901 (DISPLAY)

S323 CD

S324 VIDEO/AUX

S325 TUNER BAND

S326 TAPE DECK 1/2

LED209 (STANDBY)

S301 POWER STANDBY/ON

S302 ECO

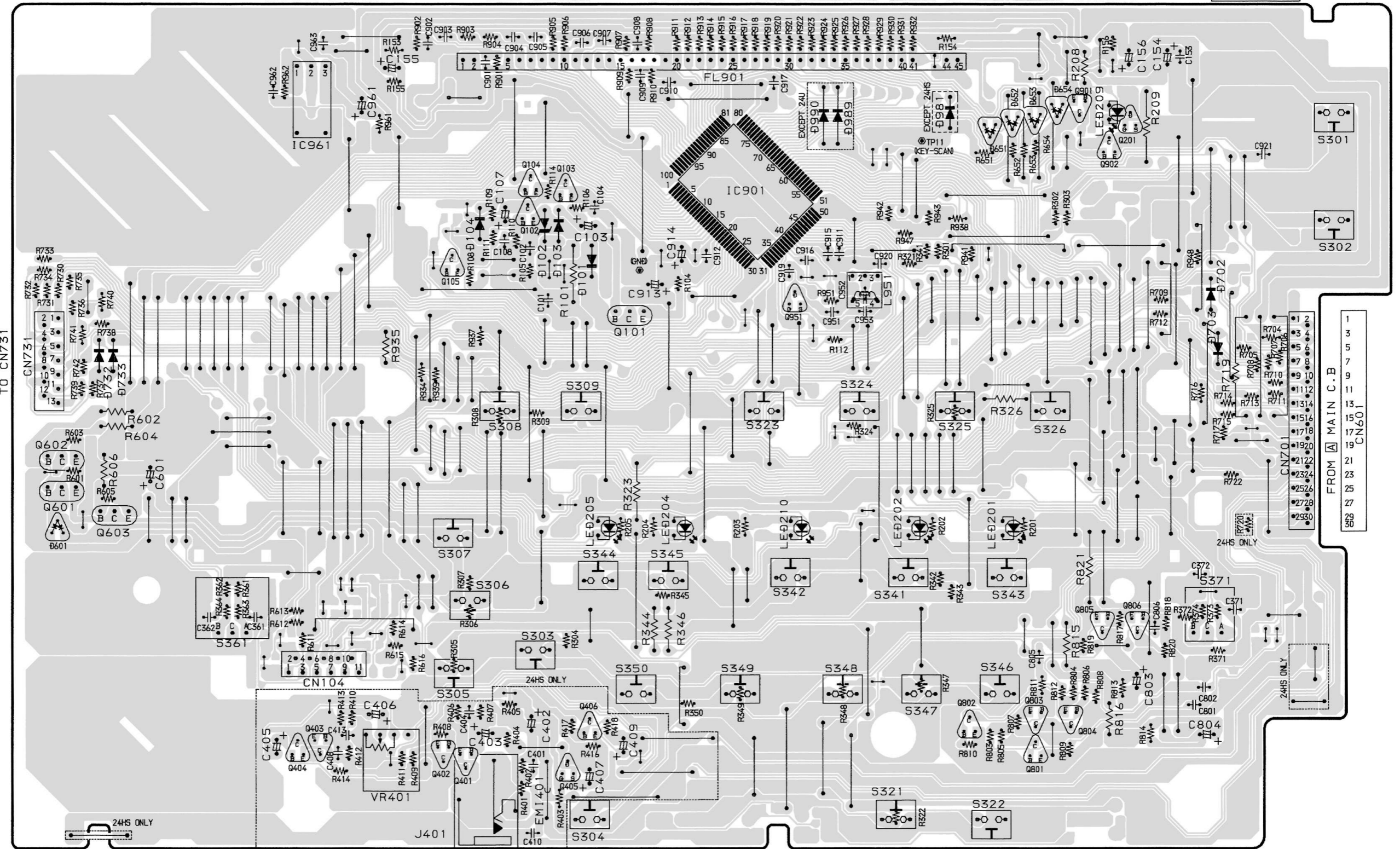
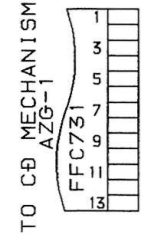

A B C D E F G H I J K L M N O P Q R S T U

S361 MULTI JOG

TO CN104

S303 ENTER

TUNING

LED210 S342

LED202 S341

LED201 S343

S371 VOLUME

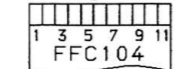

S307 ROCK

S306 POP

S305 CLASSIC

GRAPHIC EQUALIZER

LED205 S344 UP

LED204 S345 DOWN

DISC DIRECT PLAY

S348 3

S347 2

S346 1

VR401 MIC MIXING

J401 MIC

S304 TIMER

S350 OPEN/CLOSE

S349 DISC CHANGE

S321 REC/REC MUTE

S322 SYNC DUB

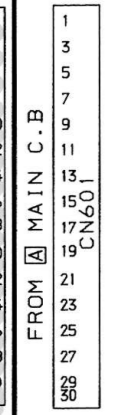



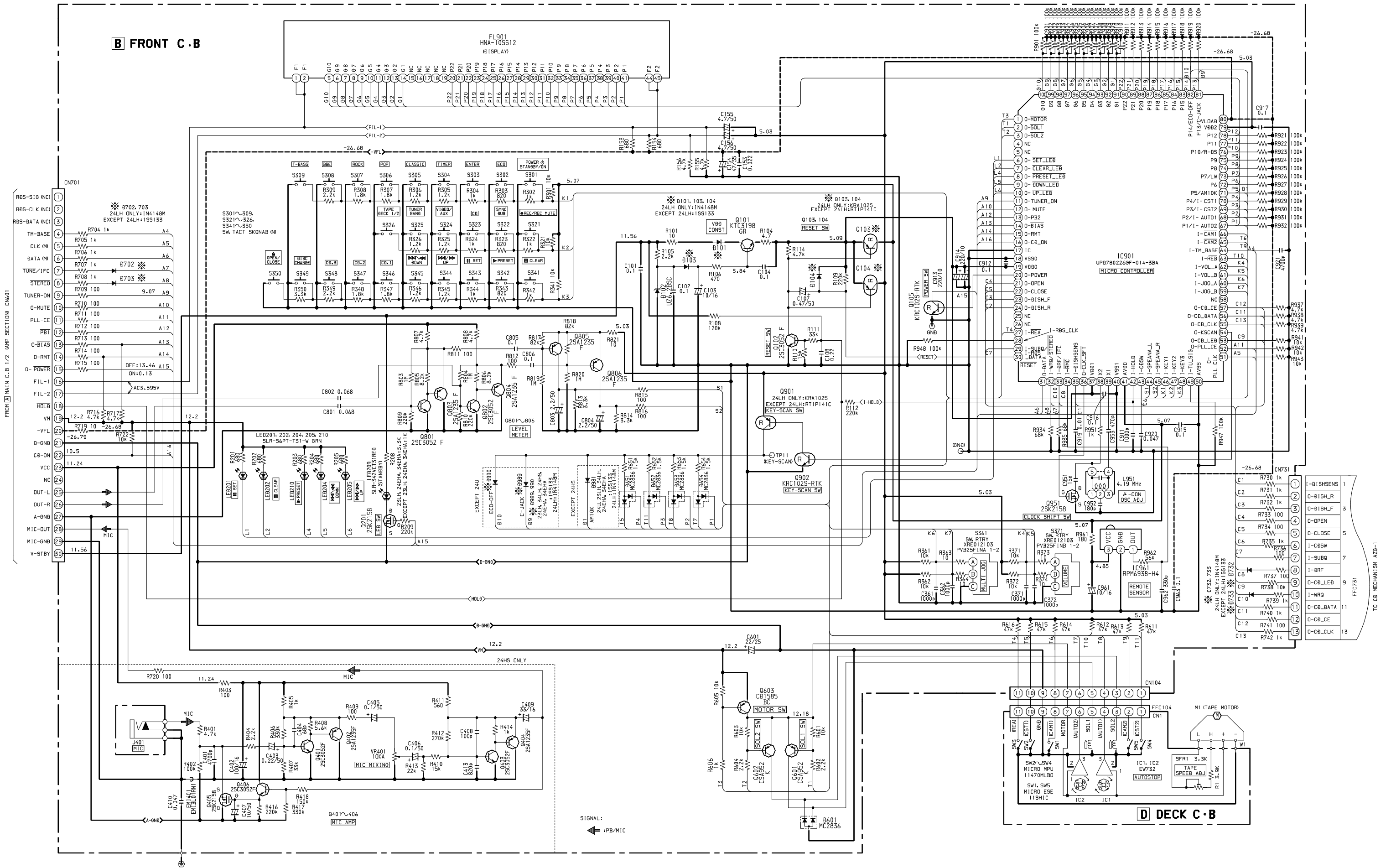

WIRING - 3 (PT) <24U ONLY>

15	14	13	12	11	10	9	8	7	6	5	4	3	2	1
----	----	----	----	----	----	---	---	---	---	---	---	---	---	---

A
B
C
D
E
F
G
H
I
J
K
L
M
N
O
P
Q
R
S
T
U

**C** PT C.B <24U ONLY>

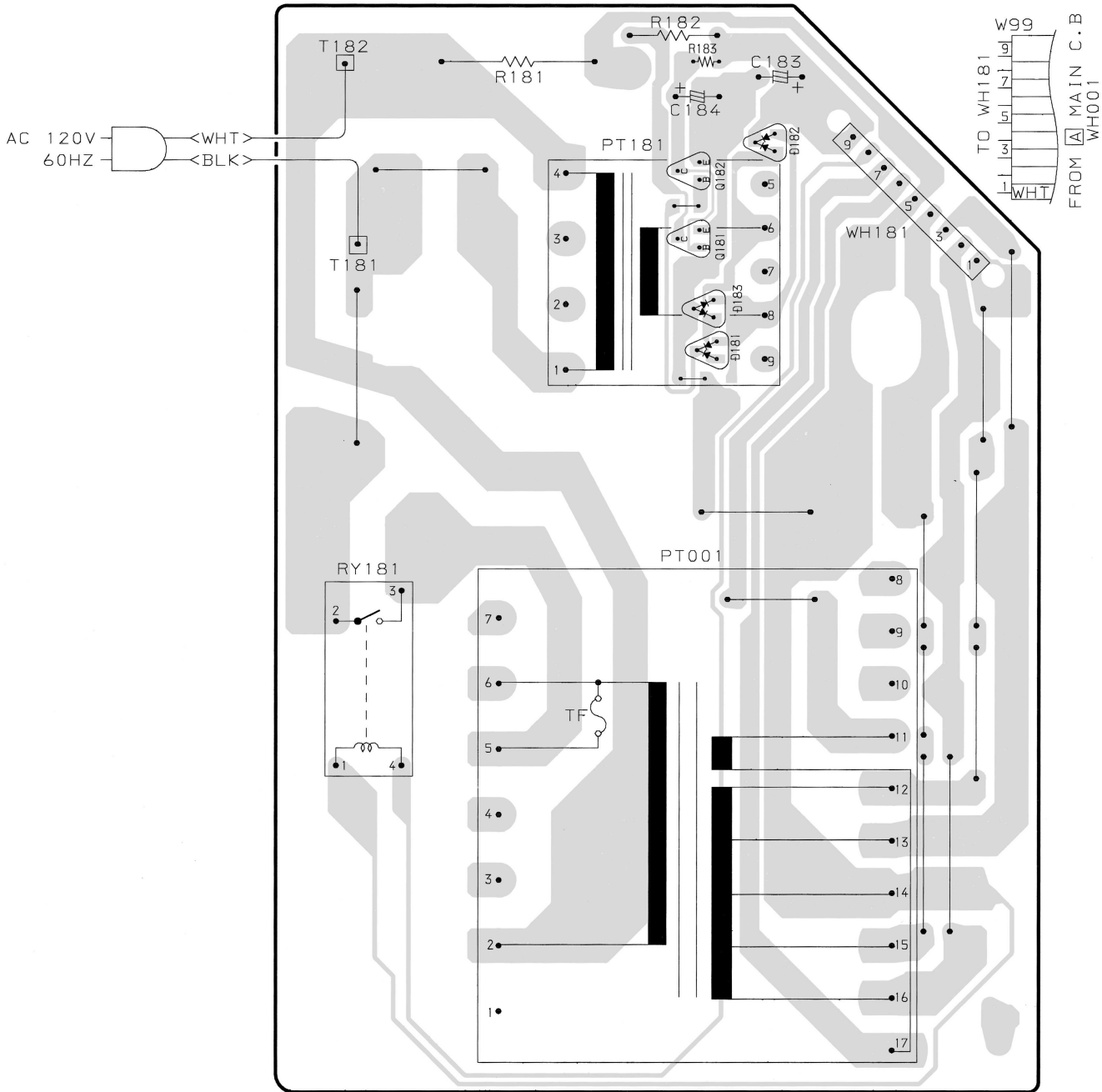

SCHEMATIC DIAGRAM - 4 (PT) <24U ONLY>

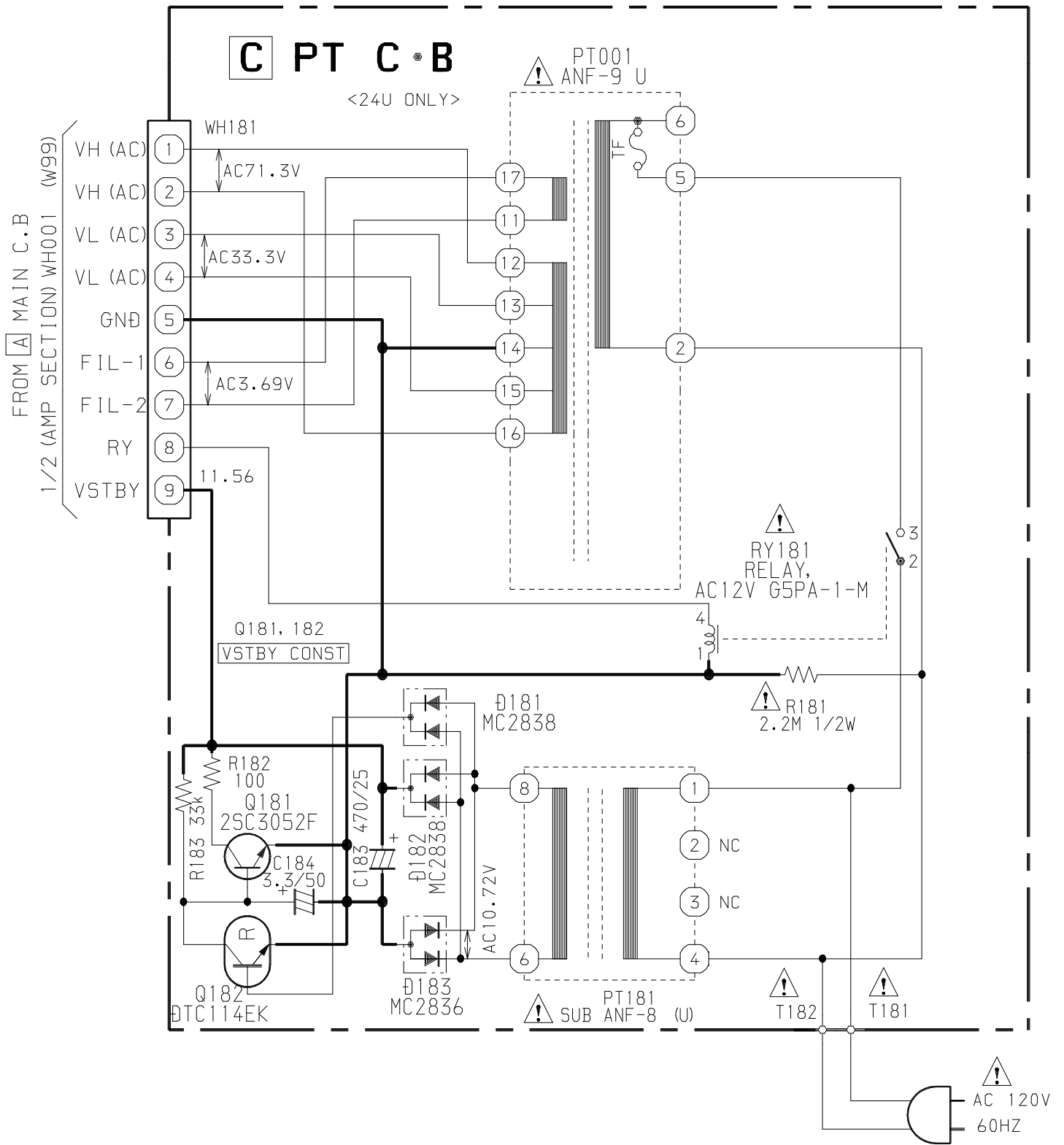

WIRING - 4 (PT) <EXCEPT 24U>

15	14	13	12	11	10	9	8	7	6	5	4	3	2	1
----	----	----	----	----	----	---	---	---	---	---	---	---	---	---

A
B
C
D
E
F
G
H
I
J
K
L
M
N
O
P
Q
R
S
T
U

C PT C.B <EXCEPT 24U>

23LH, 24LH, 34LH, 24EHA, 34EHA } AC 120V / 220-230V / 240V : 50 / 60HZ  
 24HS: AC 220V 60HZ

TO CNO01  
 15 CNA1  
 14 MAIN C.B  
 13 FORM  
 12 WH001

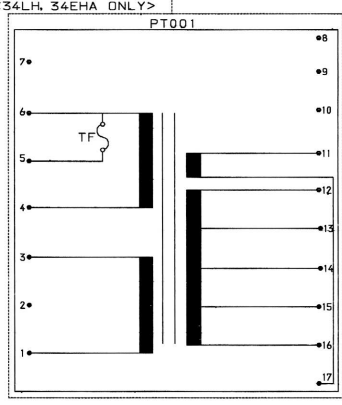
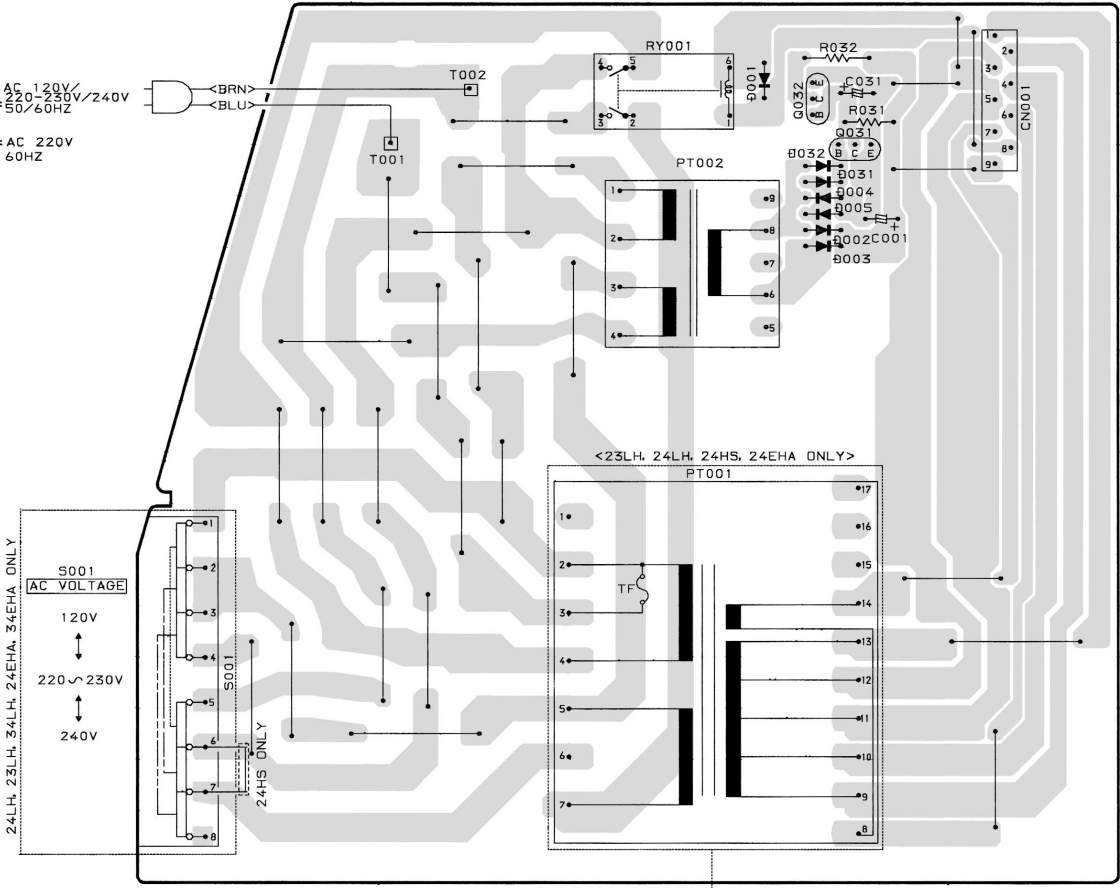

SCHEMATIC DIAGRAM - 5 (PT) <EXCEPT 24U>

FROM MAIN C.B 1/2 (AMP SECTION) WH001 (CNA1)

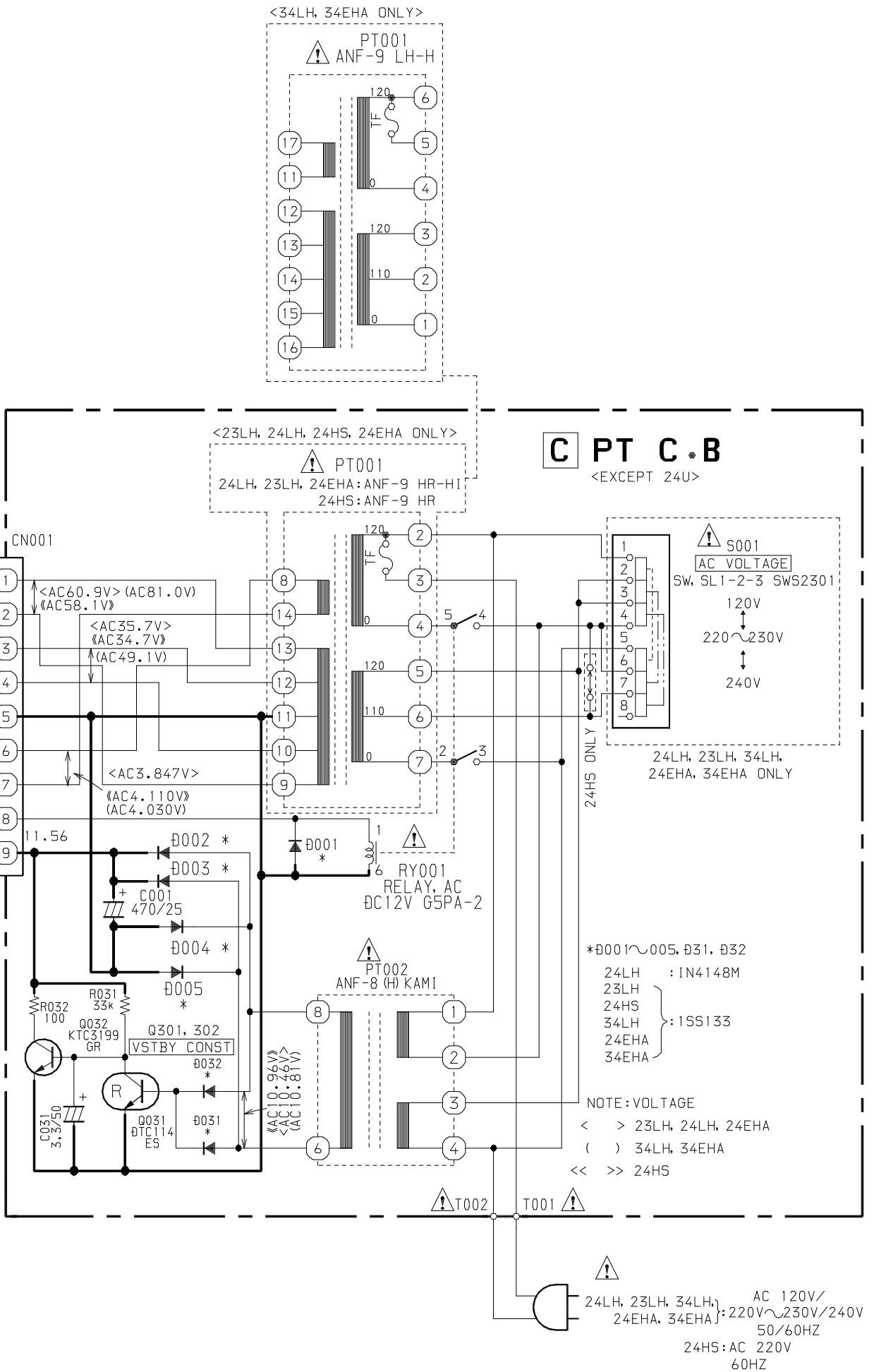

32	31	30	29	28	27	26	25	24	23	22	21	20	19	18	17	16	15	14	13	12	11	10	9	8	7	6	5	4	3	2	1
----	----	----	----	----	----	----	----	----	----	----	----	----	----	----	----	----	----	----	----	----	----	----	---	---	---	---	---	---	---	---	---

**D** DECK C.B

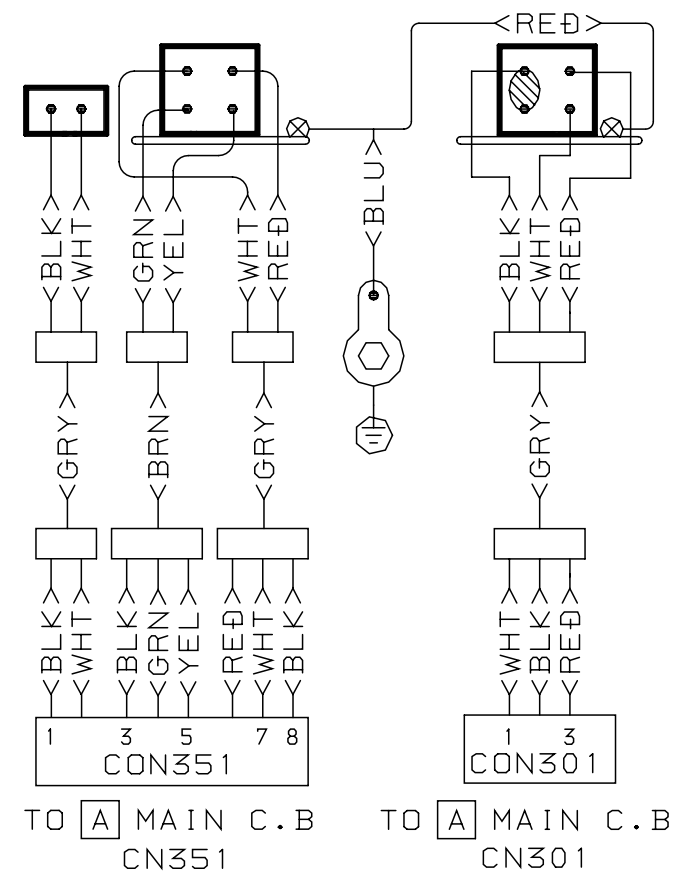
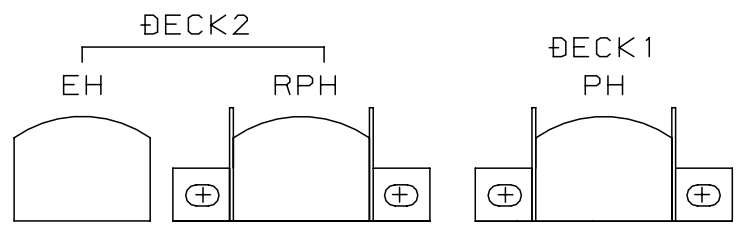
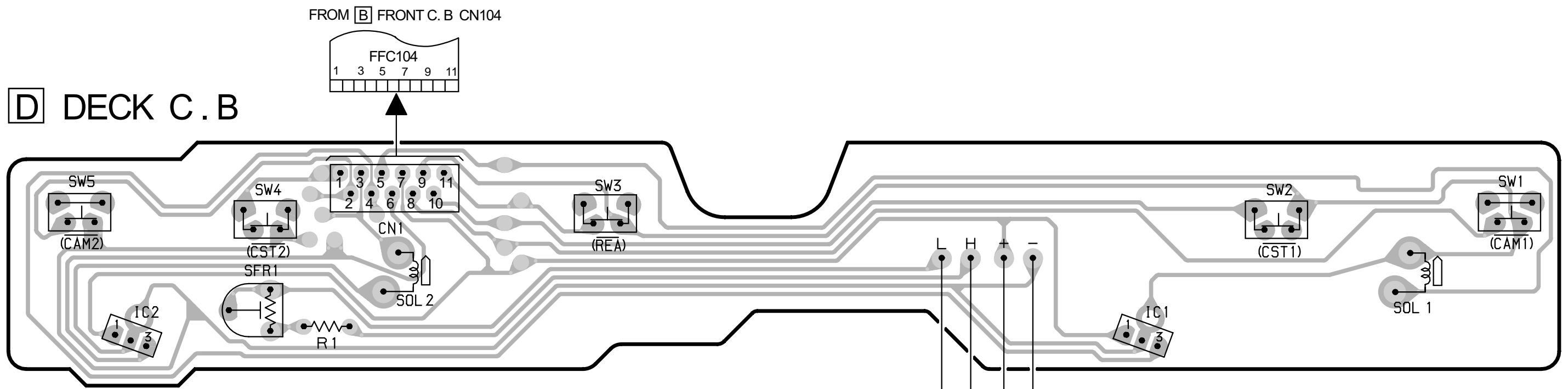

A  
B  
C  
D  
E  
F  
G  
H  
I  
J  
K  
L  
M  
N  
O  
P  
Q  
R  
S  
T  
U

# IC BLOCK DIAGRAM

IC, LA1844L-A

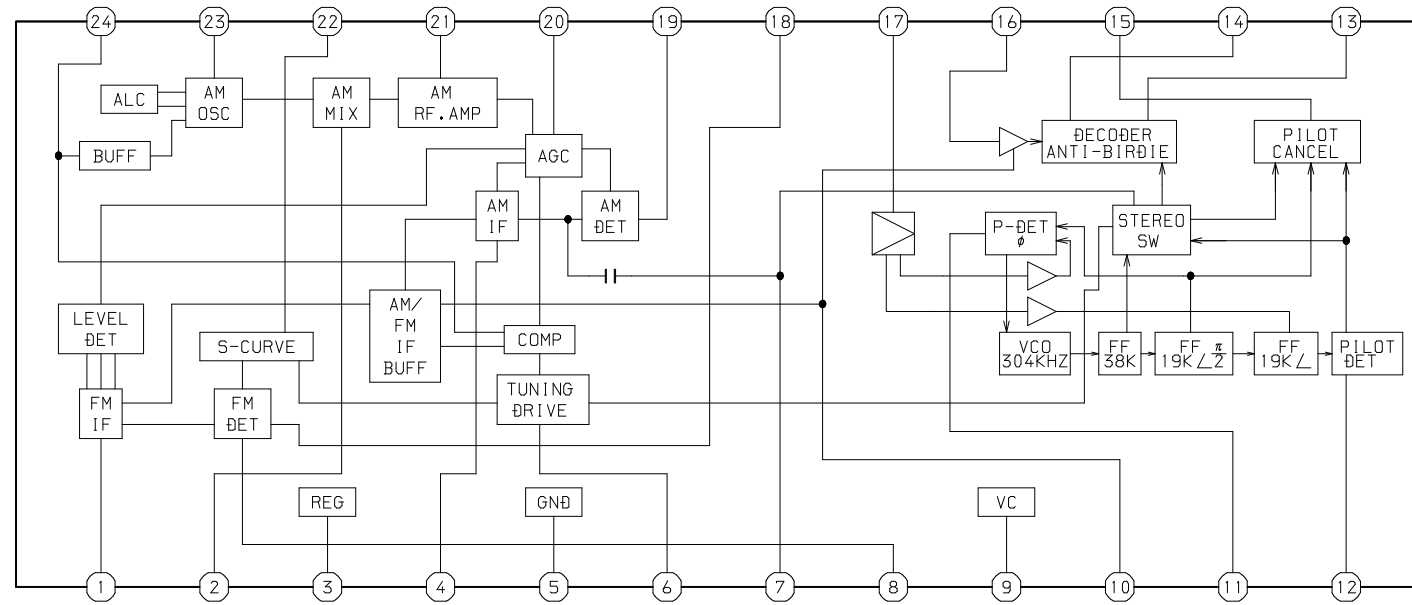

IC, LA1843

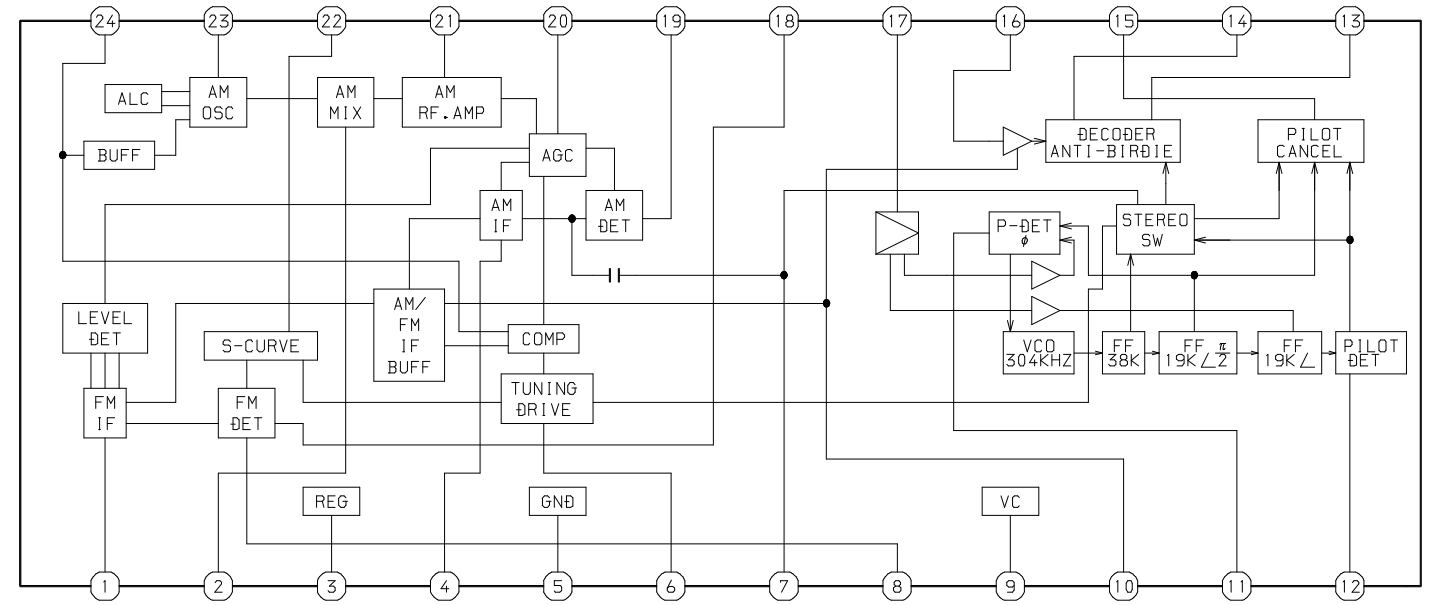

IC, LC72131D

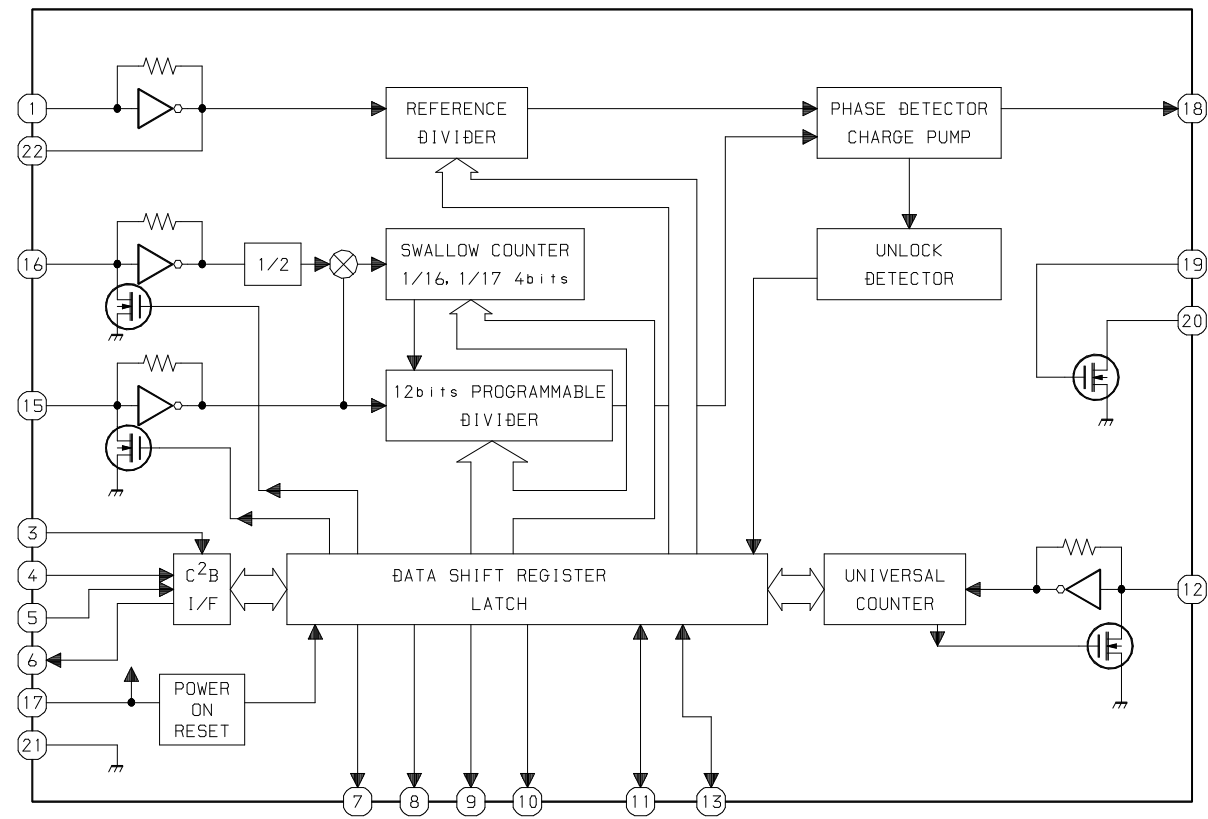

IC, M61503FP

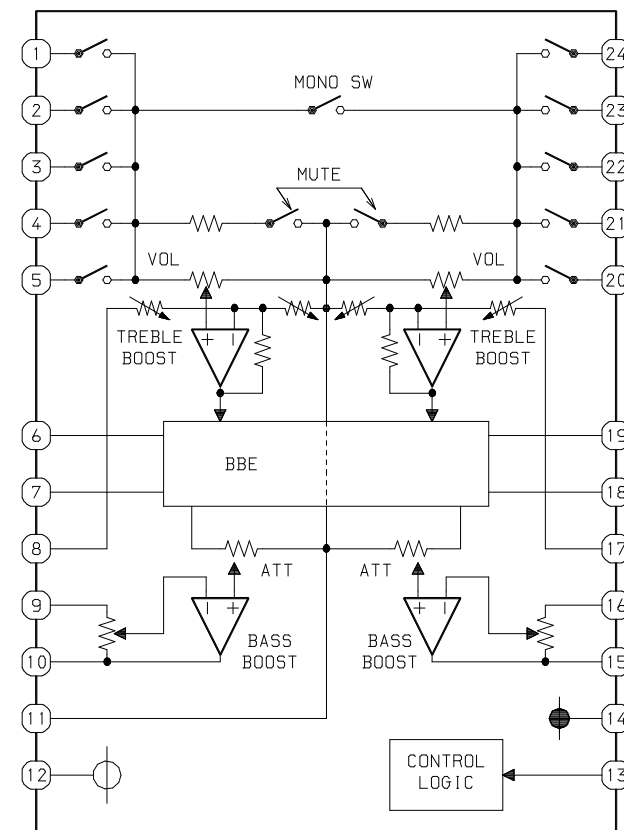

## IC DESCRIPTION

IC,  $\mu$ PD780226GF-014-3BA

Pin No.	Pin Name	I/O	Description
1	O-MOTOR	O	DECK MOTOR ON/OFF output.
2	O-SOL1	O	DECK1 solenoid output.
3	O-SOL2	O	DECK2 solenoid output.
4	NC	–	Not connected.
5	NC	–	Not connected.
6	O-SET_LED	O	SET LED ON/OFF output.
7	O-CLEAR_LED	O	CLEAR LED ON/OFF output.
8	O-PRESET_LED	O	PRESET LED ON/OFF output.
9	O-DOWN_LED	O	DOWN LED ON/OFF output.
10	O-UP_LED	O	UP LED ON/OFF output.
11	O-TUNER_ON	O	TUNER ON output.
12	O-MUTE	O	MUTE output.
13	O-PB2	O	DECK2/DECK1 play output.
14	O-BIAS	O	BIAS ON output.
15	O-RMT	O	REC mute output.
16	O-CD_ON	O	CD ON output.
17	IC	–	Internal connection (connected to GND).
18	VSS0	–	GND.
19	VDD0	–	Power supply.
20	O-POWER	O	System power supply ON/OFF output.
21	O-OPEN	O	CD tray open data output.
22	O-CLOSE	O	CD tray close data output.
23	O-DISH_F	O	CD turntable forward rotation output.
24	O-DISH_R	O	CD turntable reverse rotation output.
25	NC	–	Not connected.
26	NC	–	Not connected.
27	I-RE $\bar{A}$	I	Deck 2 side-A recordable switch data input. "L" = REC.
28	I-RDS_CLK	I	Tuner RDS clock input. (Not used)
29	I-SUBQ/I-RDS_DATA	I	CD SUBQ data input / Tuner RDS data input (not used).
30	$\overline{\text{RESET}}$	–	System reset.
31	O-DATA	O	Data output for MAIN.
32	I-WRQ/STEREO	I	CD WRQ input / Tuner stereo input.
33	I-DRF/IF $\bar{C}$	I	CD DRF input / Tune IF count serial data input.
34	I-RM $\bar{C}$	I	System remote control input.
35	I-DISHSENS	I	CD turntable photo sensor input.
36	O-CLK_SFT	O	Micon clock shift output.
37	VDD1	–	Power supply.
38	X2	–	4.19MHz oscillator circuit.
39	X1	–	4.19MHz oscillator circuit.
40	VSS1	–	GND.
41	AVDD	–	Power supply.



Pin No.	Pin Name	I/O	Description
42	I-HOLD	I	Power failure detected input.
43	I-CDSW	I	CD mecha switch input.
44	I-SPEANA_L	I	A/D L-input for spectrum analyser level display.
45	I-SPEANA_R	I	A/D R-input for spectrum analyser level display.
46	I-KEY1	I	Key1 input.
47	I-KEY2	I	Key2 input.
48	I-KEY3	I	Key3 input.
49	I-TU_SIG	I	Tuner signal input. (Not used)
50	AVSS	–	GND.
51	O-PLL_CLK	O	PLL clock enable output.
52	O-PLL_CE	O	Chip enable output for tuner PLL.
53	O-CD_LED	O	CD flash window LED ON/OFF output.
54	O-KSCAN	O	Key scan output.
55	O-CD_CLK	O	CD clock output.
56	O-CD_DATA	O	CD data output.
57	O-CD_CE	O	CD enable output.
58	NC	–	Not connected.
59	I-JOG_B	I	Dial jog rotary encoder input B.
60	I-JOG_A	I	Dial jog rotary encoder input A.
61	I-VOL_B	I	Volume rotary encoder input B.
62	I-VOL_A	I	Volume rotary encoder input A.
63	I-REB	–	Deck 2 side-B recordable switch data input. "L" = REC. (Not used)
64	I-TM_BASE	I	Base input for clock.
65	I-CAM2	I	DECK2 CAM switch data input.
66	I-CAM1	I	DECK1 CAM switch data input.
67	P1/I-AUTO2	O/I	FL segment P1 output / DECK2 AUTO STOP switch data input.
68	P2/I-AUTO1	O/I	FL segment P2 output / DECK1 AUTO STOP switch data input.
69	P3/I-CST2	O/I	FL segment P3 output / DECK2 cassette detect switch data input.
70	P4/I-CST1	O/I	FL segment P4 output / DECK1 cassette detect switch2 data input.
71	P5/AM10K	O/I	FL segment P5 output / AM10K data input <except 24HS>.
72	P6	O	FL segment P6 output.
73	P7/LW	O/I	FL segment P7 output / LW mode data input (not used).
74 ~ 75	P8 ~ P9	O	FL segment P8 ~ P9 output.
76	P10/RDS	O/I	FL segment P10 output / RDS data input (not used).
77 ~ 78	P11 ~ P12	O	FL segment P11 ~ P12 output.
79	VDD2	–	Power supply.
80	VLOAD	–	Power supply for FL display.
81	P13/C-JACK	O/I	FL segment P13 output / C-JACK data input <except 24U>.
82	P14/ECO-OFF	O/I	FL segment P14 output / ECO-OFF data input <except 24U>.
83 ~ 90	P15 ~ P22	O	FL segment P15 ~ P22 output.
91 ~100	G1 ~ G10	O	FL grid G1 ~ G10 output.

IC, LC72131D

Pin No.	Pin Name	I/O	Description																								
1	X-IN	I	A crystal oscillator (4.5MHz) is connected between these pins.																								
22	X-OUT	O																									
2	NC	–	Not connected.																								
3	CE	I	To enable the IC. Active "H".																								
4	DI	I	Digital data input from CPU ( $\mu$ PD780226GF-014-3BA) when relevant key is operated. Active "H".																								
5	CL	I	To clock in the data DI.																								
6	DO	O	Digital data output to CPU ( $\mu$ PD780226GF-014-3BA).																								
7	TM-BASE	O	Outputs a reference clock signal (8Hz) for the clock.																								
8	$\overline{\text{MONO}} / \text{BEAT}$	O	Outputs "H" when MONO / BEAT is switched.																								
9	$\overline{\text{FM}} / \overline{\text{SW}}$	O	Output "L" or "H" as follows: <table border="1" style="margin-left: 20px;"> <thead> <tr> <th colspan="2">2 BAND</th> <th colspan="3">3 BAND</th> <th colspan="3">3 BAND</th> </tr> <tr> <th>AM</th> <th>FM</th> <th>LW</th> <th>MW</th> <th>FM</th> <th>MW</th> <th>SW</th> <th>FM</th> </tr> </thead> <tbody> <tr> <td>H</td> <td>L</td> <td>H</td> <td>H</td> <td>L</td> <td>H</td> <td>L</td> <td>L</td> </tr> </tbody> </table>	2 BAND		3 BAND			3 BAND			AM	FM	LW	MW	FM	MW	SW	FM	H	L	H	H	L	H	L	L
2 BAND		3 BAND			3 BAND																						
AM	FM	LW	MW	FM	MW	SW	FM																				
H	L	H	H	L	H	L	L																				
10	$\overline{\text{MW}} / \text{SW}$	O	Outputs "L" or "H" as follows: <table border="1" style="margin-left: 20px;"> <thead> <tr> <th colspan="2">2 BAND</th> <th colspan="3">3 BAND</th> <th colspan="3">3 BAND</th> </tr> <tr> <th>AM</th> <th>FM</th> <th>LW</th> <th>MW</th> <th>FM</th> <th>MW</th> <th>SW</th> <th>FM</th> </tr> </thead> <tbody> <tr> <td>L</td> <td>L</td> <td>H</td> <td>L</td> <td>L</td> <td>L</td> <td>H</td> <td>L</td> </tr> </tbody> </table>	2 BAND		3 BAND			3 BAND			AM	FM	LW	MW	FM	MW	SW	FM	L	L	H	L	L	L	H	L
2 BAND		3 BAND			3 BAND																						
AM	FM	LW	MW	FM	MW	SW	FM																				
L	L	H	L	L	L	H	L																				
11	IF-MUTE	O	To control internal counter.																								
12	IF-IN	I	General purpose counter input.																								
13	$\overline{\text{TUNE}}$	I	Receives "L" when station is tuned.																								
14	NC	–	Not connected.																								
15	AM-IN	I	Receives the AM local oscillator frequency signal.																								
16	FM-IN	I	Receives the FM local oscillator frequency signal.																								
17	VDD	–	Supply power to IC (+5V).																								
18	PD	O	PLL charge pump output.																								
19	A-IN	I	The MOS transistor used for PLL active low pass filter.																								
20	A-OUT	O																									
21	VSS	–	Ground.																								

# ADJUSTMENT – 1 <TUNER / DECK>

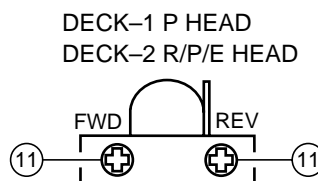
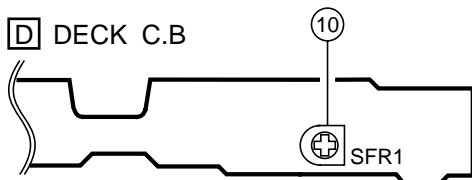
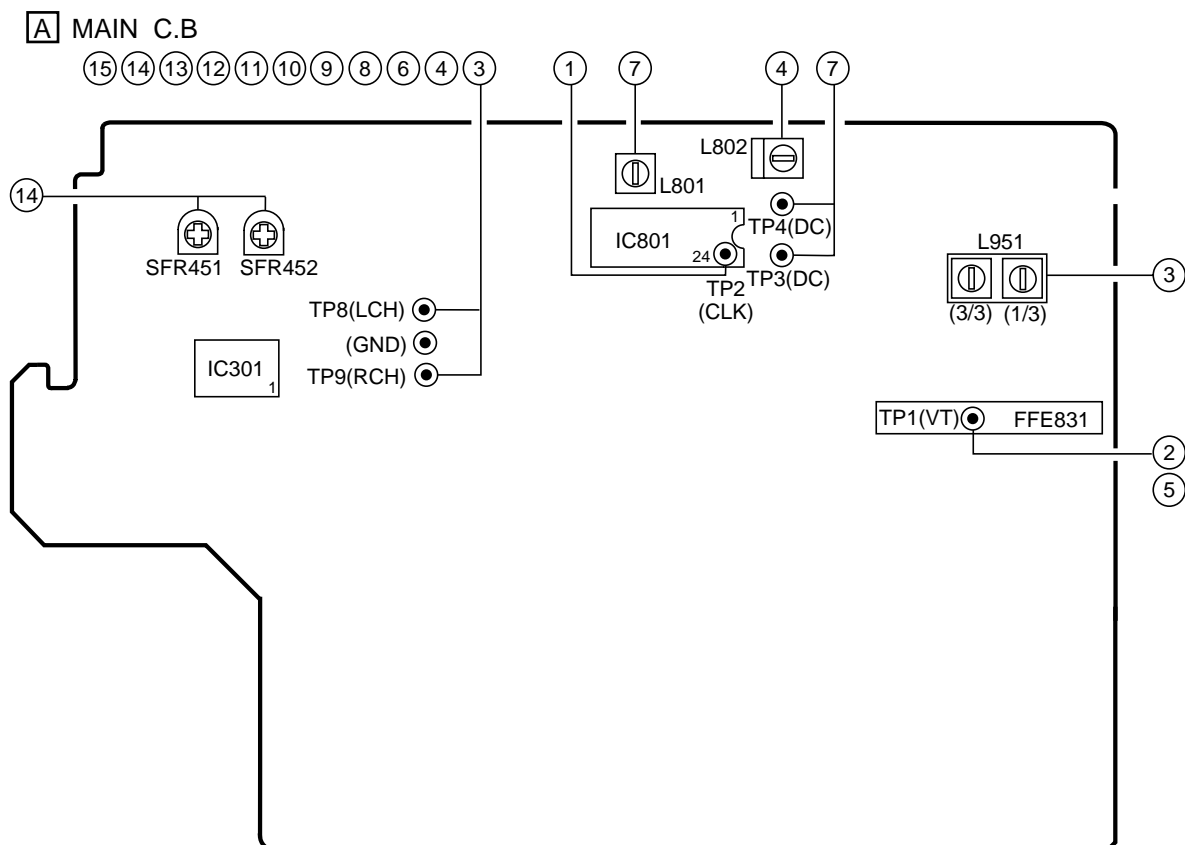

## < TUNER SECTION >

1. Clock frequency Check
  - Settings : • Test point : TP2 (CLK)
  - Method : Set to AM 1710kHz <LH,U,HA>, AM 1602 kHz <HS> and check that the test point is 2160kHz ± 45Hz <LH,U,HA>, 2052kHz ± 45Hz <HS>.
2. AM VT Check
  - Settings : • Test point : TP1 (VT)
  - Method : Set to AM 1710kHz <LH,U,HA>, AM 1602 kHz <HS> and check that the test point is less than 8.5V <LH,U,HA>, less than 8.0V <HS>. Then set to AM 530kHz <LH,U,HA>, AM 531kHz <HS> and check that the test point is more than 0.6V.
3. AM Tracking Adjustment
  - Settings : • Test point : TP8 (Lch), TP9 (Rch)
  - Adjustment location : L951(1/3)
  - Method : Set to AM 1000kHz <LH,U,HA>, AM 999kHz <HS> and adjust L951(1/3) so that the test point becomes maximum.
4. AM IF Adjustment
  - Settings : • Test point : TP8 (Lch), TP9 (Rch)
  - Adjustment location : L802 ..... 450kHz
5. FM VT Check
  - Settings : • Test point : TP1 (VT)
  - Method : Set to FM 87.5MHz and check that the test point is more than 0.5V. Then set to FM 108.0MHz and check that the test point is less than 8.0V.
6. FM Tracking Check
  - Settings : • Test point : TP8 (Lch), TP9 (Rch)
  - Method : Set to FM 98.0MHz and check that the test point is less than 9dBμV.

7. DC Balance / Mono Distortion Adjustment

Settings : • Test point : TP3, TP4 (DC)  
• Adjustment location : L801  
• Input level : 60dB $\mu$ V

Method : Set to FM 98.0MHz and adjust L801 to achieve minimum distortion. Then check that the voltage between TP3 and TP4 is within 0V  $\pm$  300mV.

8. Output Level Check

<AM>

Settings : • Test point : TP8 (Lch), TP9 (Rch)  
• Input level : 74dB $\mu$ V

Method : Set to AM 1000kHz <LH,U,HA>, AM 999kHz <HS> and check that the test point is 40mV  $\pm$  3dB.

<FM>

Settings : • Test point : TP8 (Lch), TP9 (Rch)  
• Input level : 60dB $\mu$ V

Method : Set to FM 98.0MHz and check that the test point is 140mV  $\pm$  3dB.

9. FM Separation Check

Settings : • Test point : TP8 (Lch), TP9 (Rch)  
• Input level : 60dB $\mu$ V

Method : Set to FM 98.0MHz and check that the test point is more than 25dB.

< DECK SECTION >

10. Tape Speed Adjustment (DECK 2)

Settings : • Test tape : TTA-100  
• Test point : TP8 (Lch), TP9 (Rch)  
• Adjustment location : SFR1

Method : Play back the 3kHz signal of the test tape and adjust SFR1 so that the test point becomes 3000Hz  $\pm$  5Hz (FWD) and FWD SPEED  $\pm$  45Hz (REV).

11. Head Azimuth Adjustment (DECK 1, DECK 2)

Settings : • Test tape : TTA-330  
• Test point : TP8 (Lch), TP9 (Rch)  
• Adjustment location : Head azimuth adjustment screw

Method : Play back (FWD) the 8kHz signal of the test tape and adjust screw so that the output becomes maximum. Next, perform on REV PLAY mode.

12. PB Frequency Response Check (DECK 1, DECK 2)

Settings : • Test tape : TTA-330  
• Test point : TP8 (Lch), TP9 (Rch)

Method : Play back the 315Hz and 8kHz signals of the test tape and check that the output ratio of the 8kHz signal with respect to that of the 315Hz signal is 0dB  $\pm$  5dB.

13. PB Sensitivity Check (DECK 1, DECK 2)

Settings : • Test tape : TTA-200  
• Test point : TP8 (Lch), TP9 (Rch)

Method : Play back the test tape and check that the output level of the test point is 110mV  $\pm$  3dB.

14. REC/PB Frequency Response Adjustment (DECK 2)

Settings : • Test tape : TTA-602  
• Test point : TP8 (Lch), TP9 (Rch)  
• Input signal : 1kHz / 8kHz  
(-20VU / -26dBV)  
• Adjustment location : SFR451 (Lch)  
SFR452 (Rch)

Method : Apply a 1kHz signal and REC mode. Then adjust OSC attenuator so that the output level at the TP8, TP9 becomes 5.5mV  $\sim$  9.5mV. Record and play back the 1kHz and 8kHz signals and adjust SFRs so that the output of the 8kHz signals becomes 0dB  $\pm$  0.5dB <LH,HA,HS>, -1.5dB  $\pm$  0.5dB <U> with respect to that of the 1kHz signal.

15. REC/PB Sensitivity Check (DECK 2)

Settings : • Test tape : TTA-602  
• Test point : TP8 (Lch), TP9 (Rch)  
• Input signal : 1kHz (0VU / -6dBV)

Method : Apply a 1kHz signal and REC mode. Then adjust OSC attenuator so that the output level at TP8, TP9 becomes 55mV  $\sim$  95mV. Record and play back the 1kHz signals and check that the output is -1dB  $\pm$  3.5dB.

# ADJUSTMENT – 2 <FRONT>

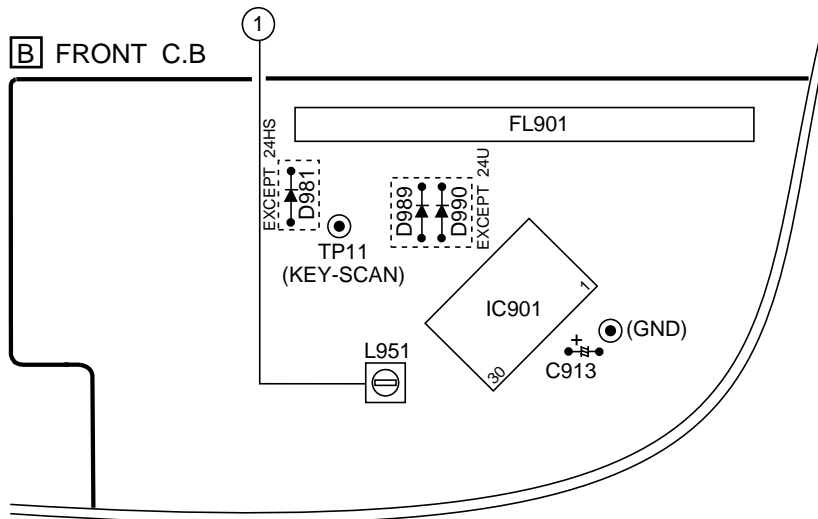

## < FRONT SECTION >

### 1. $\mu$ -CON OSC Adjustment

Settings : • Test point : TP11 (KEY-SCAN), (GND)  
 • Adjustment location : L951

Method : Connect a frequency counter across TP11 and GND via a CR network filter as shown below.

Then adjust L951 so that the test point becomes  $184.94\text{Hz} \pm 0.18\text{Hz}$ .

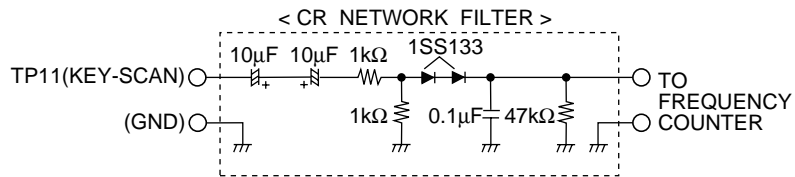

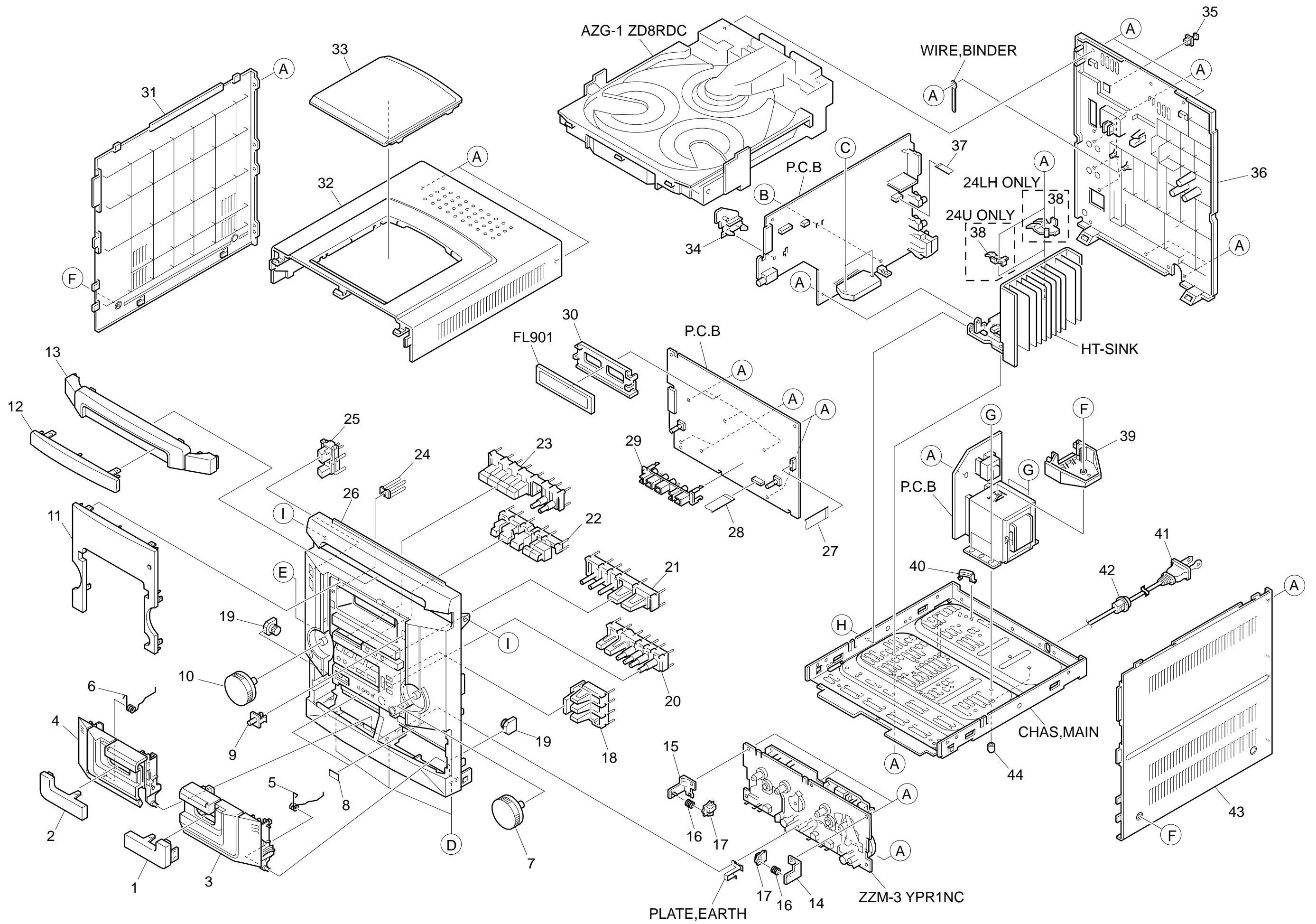

# MECHANICAL PARTS LIST 1 / 1 (NSX-AJ24) <U>, (NSX-BL24) <LH>

REF. NO.	PART NO.	KANRI NO.	DESCRIPTION	REF. NO.	PART NO.	KANRI NO.	DESCRIPTION
1	8A-NF0-007-010		WINDOW,CASS 2	30	82-NF7-210-110		GUIDE,FL(*)
2	8A-NF0-006-010		WINDOW,CASS 1	31	8A-NF8-007-010		PANEL,LEFT V-2
3	8A-NF0-004-010		BOX,CASS 2	32	8A-NF8-005-010		PANEL,TOP
4	8A-NF0-003-010		BOX,CASS 1	33	8A-NF8-006-010		WINDOW,TOP
5	8A-NF8-208-010		SPR-T,EJECT 2	34	8A-NF8-206-010		HLDR,PWB M
6	8A-NF8-207-010		SPR-T,EJECT 1	35	84-ZG1-245-210		CAP,OPTICAL
7	8A-NF0-016-010		KNOB,RTRY JOG	36	8A-NF0-062-010		CABI,REAR LHSC 24<24LHSC>
8	81-532-080-010		LABEL, CASS. COMPT	36	8A-NF0-061-010		CABI,REAR USC<24USC>
9	8A-NF0-056-010		LENS,REMOCON	37	88-906-251-110		FF-CABLE,6P 1.25
10	8A-NF0-016-010		KNOB,RTRY VOL	38	8A-NF8-205-010		HLDR,IC<24LHSC>
11	8A-NF0-005-010		WINDOW,DISP U	38	86-NF6-211-010		HLDR,IC T1.6<24USC>
12	8A-NF0-038-010		WINDOW,CD	39	8A-NF9-211-010		HLDR,PWB PT HI
13	8A-NF0-014-010		PANEL,TRAY	40	87-NF4-221-010		HLDR,CABLE
14	87-NF4-217-110		HLDR,LOCK 2	△	41	87-A80-092-010	AC CORD ASSY,E BLK SUN FAI<24LHSC>
15	87-NF4-216-010		HLDR,LOCK 1	△	41	87-A80-110-010	AC CORD ASSY,U SPT-2W<24USC>
16	86-NF9-224-010		SPR-C,LOCK	42	87-085-185-010		BUSHING, AC CORD (E)<24LHSC>
17	82-NF5-229-010		PLATE,LOCK	42	87-A91-422-010		BUSHING,AC CORD(U)<24USC>
18	8A-NF0-025-010		KEY,ENTER	43	8A-NF8-008-010		PANEL,RIGHT V-2
19	8A-NF8-209-010		OIL-DMPR,120	44	8Z-NB8-240-010		COVER, PL
20	8A-NF0-018-010		KEY,SYNC	A	87-067-703-010		TAPPING SCREW, BVT2+3-10
21	8A-NF0-019-010		KEY,CD	B	87-NF4-224-010		S-SCREW,IT3B+3-8 CU
22	8A-NF0-010-010		KEY,ASSY OPE 1 WAY	C	87-067-581-010		TAPPING SCREW, BVT2+3-15
23	8A-NF0-009-010		KEY,FUN	D	87-067-689-010		TAPPING SCREW, BVT+3-8
24	8A-NF0-021-010		REFLECTOR,ECO	E	87-723-096-410		QT2+3-10W/O SLOT BL
25	8A-NF0-008-010		KEY,POWER	F	87-067-641-010		UTT2+3-8(W/O SLOT)BL
26	8A-NF0-026-010		CABI,FR LH 24<24LHSC>	G	87-078-191-010		S-SCREW,IT+4-10
26	8A-NF0-001-010		CABI,FR U<24USC>	H	87-721-096-410		QT2+3-10 GLD
27	88-913-301-110		FF-CABLE,13P-1.25	I	87-721-097-410		QT2+3-12 GLD
28	88-911-101-110		FF-CABLE,11P 1.25				
29	8A-NF0-201-010		GUIDE,OPE 1 WAY				

## COLOR NAME TABLE

Basic color symbol	Color	Basic color symbol	Color	Basic color symbol	Color
B	Black	C	Cream	D	Orange
G	Green	H	Gray	L	Blue
LT	Transparent Blue	N	Gold	P	Pink
R	Red	S	Silver	ST	Titan Silver
T	Brown	V	Violet	W	White
WT	Transparent White	Y	Yellow	YT	Transparent Yellow
LM	Metallic Blue	LL	Light Blue	GT	Transparent Green
LD	Dark Blue	DT	Transparent Orange	GM	Metallic Green
YM	Metallic Yellow	DM	Metallic Orange		

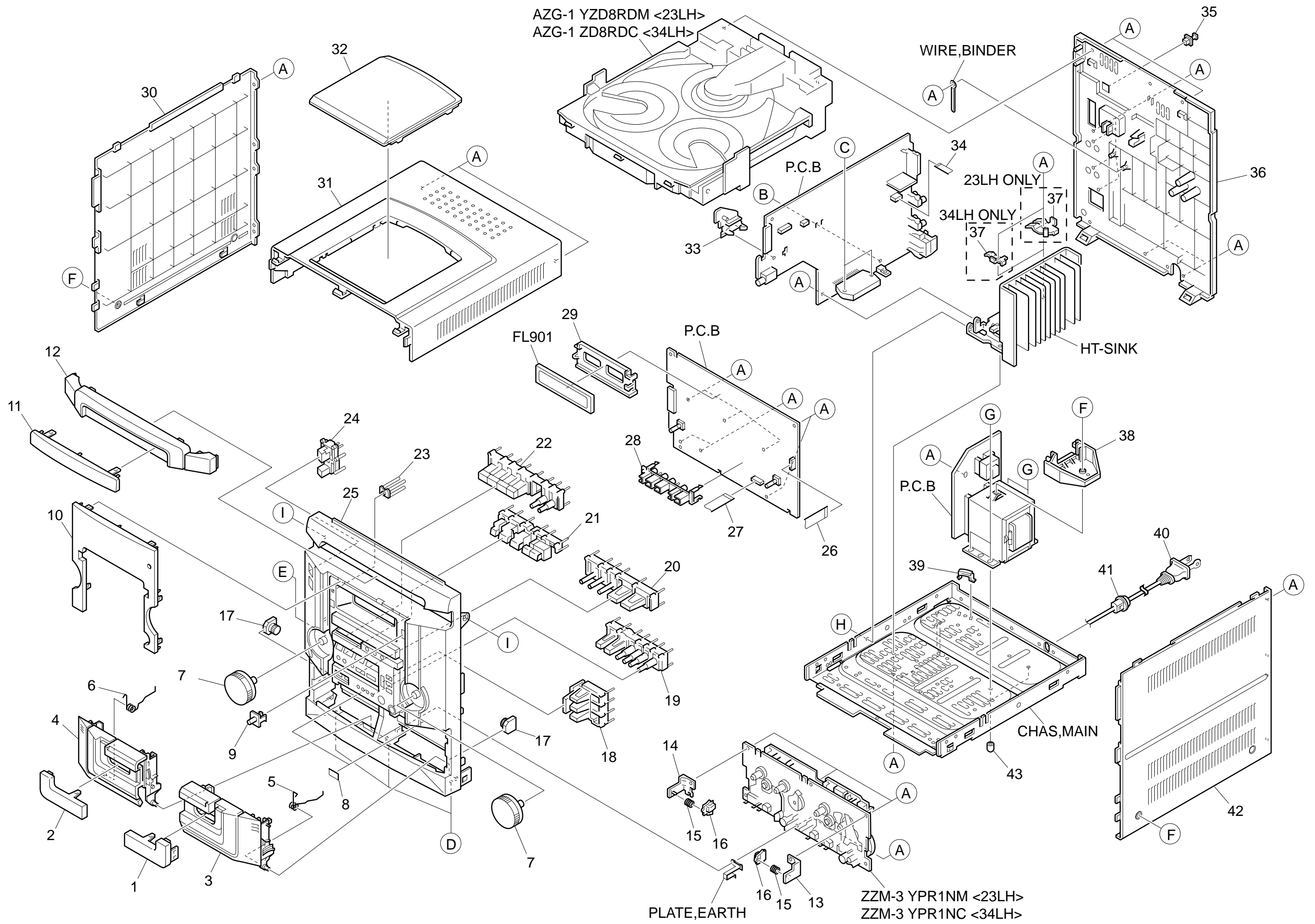



# MECHANICAL PARTS LIST 1 / 1 (NSX-BL23 / BL34) <LH>

REF. NO.	PART NO.	KANRI NO.	DESCRIPTION	REF. NO.	PART NO.	KANRI NO.	DESCRIPTION
1	8A-NF0-007-010		WINDOW,CASS 2	30	8A-NF8-007-010		PANEL,LEFT V-2
2	8A-NF0-006-010		WINDOW,CASS 1	31	8A-NF8-005-010		PANEL, TOP
3	8A-NF0-004-010		BOX,CASS 2	32	8A-NF8-006-010		WINDOW, TOP
4	8A-NF0-003-010		BOX,CASS 1	33	8A-NF8-206-010		HLDR,PWB M
5	8A-NF8-208-010		SPR-T,EJECT 2	34	88-906-251-110		FF-CABLE,6P 1.25
6	8A-NF8-207-010		SPR-T,EJECT 1	35	84-ZG1-245-210		CAP,OPTICAL
7	8A-NF0-016-010		KNOB,RTRY VOL	36	8A-NFX-005-010		CABI,REAR LH W/O SPEC<23LHSC3M>
8	81-532-080-010		LABEL, CASS. COMPT	36	8A-NF0-063-010		CABI,REAR LHSC 34<34LHSC>
9	8A-NF0-056-010		LENS,REMOCON	37	8A-NF8-205-010		HLDR,IC<23LHSC3M>
10	8A-NF0-005-010		WINDOW,DISP U	37	86-NF6-211-010		HLDR,IC T1.6<34LHSC>
11	8A-NF0-038-010		WINDOW,CD	38	8A-NF9-211-010		HLDR,PWB PT HI
12	8A-NF0-014-010		PANEL, TRAY	39	87-NF4-221-010		HLDR,CABLE
13	87-NF4-217-110		HLDR,LOCK 2	△ 40	87-A80-157-010		AC CORD ASSY,E BLK CC
14	87-NF4-216-010		HLDR,LOCK 1	41	87-085-185-010		BUSHING, AC CORD(E)
15	86-NF9-224-010		SPR-C,LOCK	42	8A-NF8-008-010		PANEL,RIGHT V-2
16	82-NF5-229-010		PLATE,LOCK	43	8Z-NB8-240-010		COVER, PL
17	8A-NF8-209-010		OIL-DMPR,120	A	87-067-703-010		TAPPING SCREW, BVT2+3-10
18	8A-NF0-025-010		KEY,ENTER	B	87-NF4-224-010		S-SCREW,IT3B+3-8 CU
19	8A-NF0-018-010		KEY,SYNC	C	87-067-581-010		TAPPING SCREW, BVT2+3-15
20	8A-NF0-019-010		KEY,CD	D	87-067-689-010		TAPPING SCREW, BVTT+3-8
21	8A-NF0-010-010		KEY,ASSY OPE 1 WAY	E	87-723-096-410		QT2+3-10W/O SLOT BL
22	8A-NF0-009-010		KEY,FUN	F	87-067-641-010		UTT2+3-8(W/O SLOT)BL
23	8A-NF0-021-010		REFLECTOR,ECO	G	87-078-191-010		S-SCREW,IT+4-10
24	8A-NF0-008-010		KEY,POWER	H	87-721-096-410		QT2+3-10 GLD
25	8A-NF0-027-010		CABI,FR LH 34<34LHSC>	I	87-721-097-410		QT2+3-12 GLD
25	8A-NF0-040-010		CABI,FR LHSC3M 24J<23LHSC3M>				
26	88-913-301-110		FF-CABLE,13P-1.25				
27	88-911-101-110		FF-CABLE,11P 1.25				
28	8A-NF9-201-010		GUIDE,OPE 1 WAY				
29	82-NF7-210-110		GUIDE,FL(*)				

## COLOR NAME TABLE

Basic color symbol	Color	Basic color symbol	Color	Basic color symbol	Color
B	Black	C	Cream	D	Orange
G	Green	H	Gray	L	Blue
LT	Transparent Blue	N	Gold	P	Pink
R	Red	S	Silver	ST	Titan Silver
T	Brown	V	Violet	W	White
WT	Transparent White	Y	Yellow	YT	Transparent Yellow
LM	Metallic Blue	LL	Light Blue	GT	Transparent Green
LD	Dark Blue	DT	Transparent Orange	GM	Metallic Green
YM	Metallic Yellow	DM	Metallic Orange		

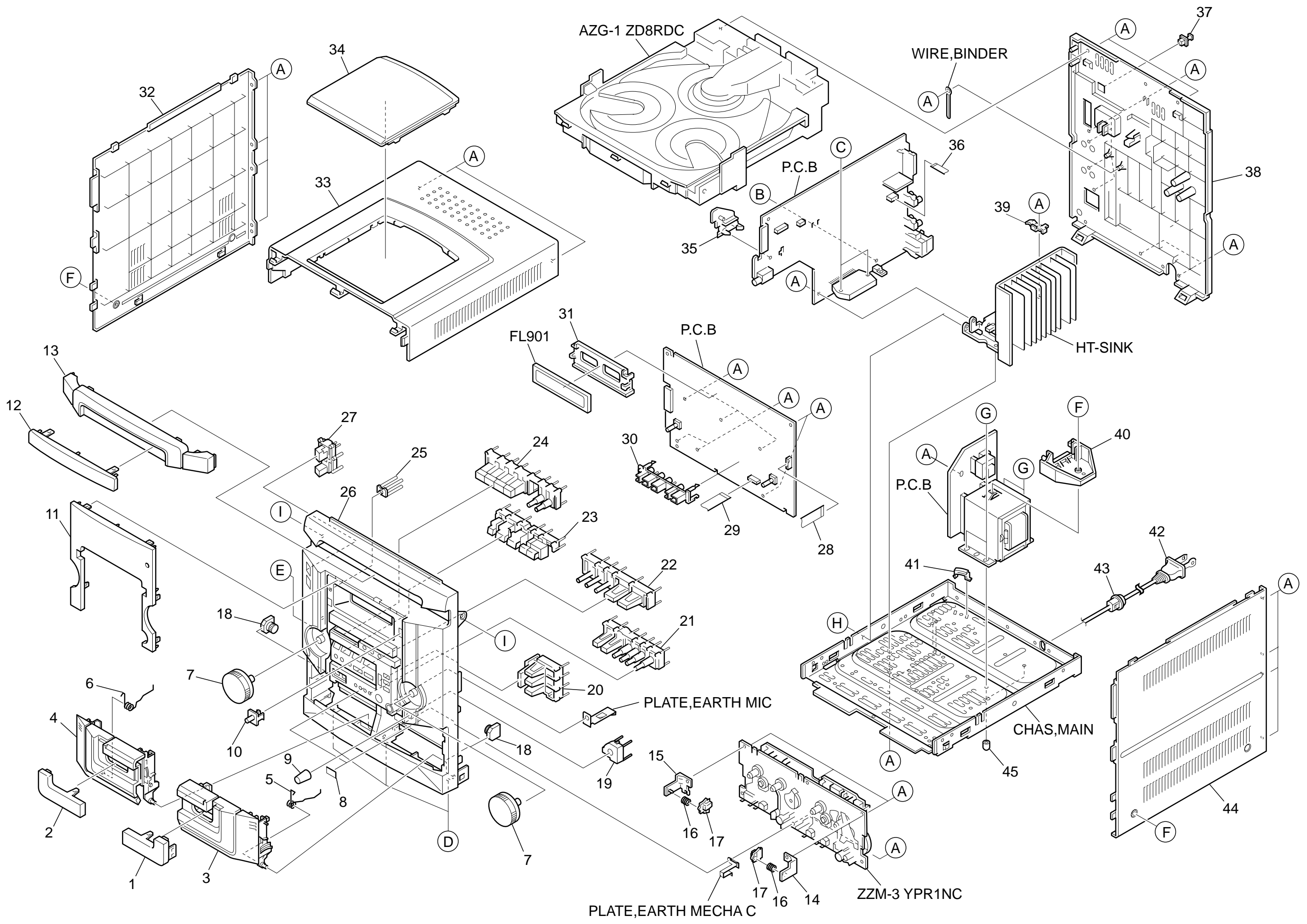

# MECHANICAL PARTS LIST 1 / 1 (NSX-BL24) <HS>

REF. NO.	PART NO.	KANRI NO.	DESCRIPTION	REF. NO.	PART NO.	KANRI NO.	DESCRIPTION
1	8A-NF0-007-010		WINDOW,CASS 2	31	82-NF7-210-110		GUIDE,FL(*)
2	8A-NF0-006-010		WINDOW,CASS 1	32	8A-NF8-007-010		PANEL,LEFT V-2
3	8A-NF0-004-010		BOX,CASS 2	33	8A-NF8-005-010		PANEL,TOP
4	8A-NF0-003-010		BOX,CASS 1	34	8A-NF8-006-010		WINDOW,TOP
5	8A-NF8-208-010		SPR-T,EJECT 2	35	8A-NF8-206-010		HLDR,PWB M
6	8A-NF8-207-010		SPR-T,EJECT 1	36	88-906-251-110		FF-CABLE,6P 1.25
7	8A-NF0-016-010		KNOB,RTRY VOL	37	84-ZG1-245-210		CAP,OPTICAL
8	81-532-080-010		LABEL,CASS. COMPT	38	8A-NF0-070-010		CABI,REAR HS
9	8A-NF9-015-010		KNOB,RTRY MIC	39	8A-NF8-216-010		HLDR,IC C
10	8A-NF0-056-010		LENS,REMOCON	40	8A-NF9-211-010		HLDR,PWB PT HI
11	8A-NF0-005-010		WINDOW,DISP U	41	87-NF4-221-010		HLDR,CABLE
12	8A-NF0-038-010		WINDOW,CD	△ 42	87-A80-155-010		AC CORD ASSY,HS TS
13	8A-NF0-014-010		PANEL,TRAY	43	87-085-185-010		BUSHING, AC CORD(E)
14	87-NF4-217-110		HLDR,LOCK 2	44	8A-NF8-008-010		PANEL,RIGHT V-2
15	87-NF4-216-010		HLDR,LOCK 1	45	8Z-NB8-240-010		COVER, PL
16	86-NF9-224-010		SPR-C,LOCK	A	87-067-703-010		TAPPING SCREW, BVT2+3-10
17	82-NF5-229-010		PLATE,LOCK	B	87-NF4-224-010		S-SCREW,IT3B+3-8 CU
18	8A-NF8-209-010		OIL-DMPR,120	C	87-067-581-010		TAPPING SCREW, BVT2+3-15
19	8A-NF9-021-010		PLATE,MIC	D	87-067-689-010		TAPPING SCREW, BVT2+3-8
20	8A-NF0-025-010		KEY,ENTER	E	87-723-096-410		QT2+3-10W/O SLOT BL
21	8A-NF0-018-010		KEY,SYNC	F	87-067-641-010		UTT2+3-8(W/O SLOT)BL
22	8A-NF0-019-010		KEY,CD	G	87-078-191-010		S-SCREW,IT4-10
23	8A-NF0-010-010		KEY,ASSY OPE 1 WAY	H	87-721-096-410		QT2+3-10 GLD
24	8A-NF0-009-010		KEY,FUN	I	87-721-097-410		QT2+3-12 GLD
25	8A-NF0-021-010		REFLECTOR,ECO				
26	8A-NF0-032-010		CABI,FR HS				
27	8A-NF0-008-010		KEY,POWER				
28	88-913-301-110		FF-CABLE,13P-1.25				
29	88-911-101-110		FF-CABLE,11P 1.25				
30	8A-NF9-201-010		GUIDE,OPE 1 WAY				

## COLOR NAME TABLE

Basic color symbol	Color	Basic color symbol	Color	Basic color symbol	Color
B	Black	C	Cream	D	Orange
G	Green	H	Gray	L	Blue
LT	Transparent Blue	N	Gold	P	Pink
R	Red	S	Silver	ST	Titan Silver
T	Brown	V	Violet	W	White
WT	Transparent White	Y	Yellow	YT	Transparent Yellow
LM	Metallic Blue	LL	Light Blue	GT	Transparent Green
LD	Dark Blue	DT	Transparent Orange	GM	Metallic Green
YM	Metallic Yellow	DM	Metallic Orange		

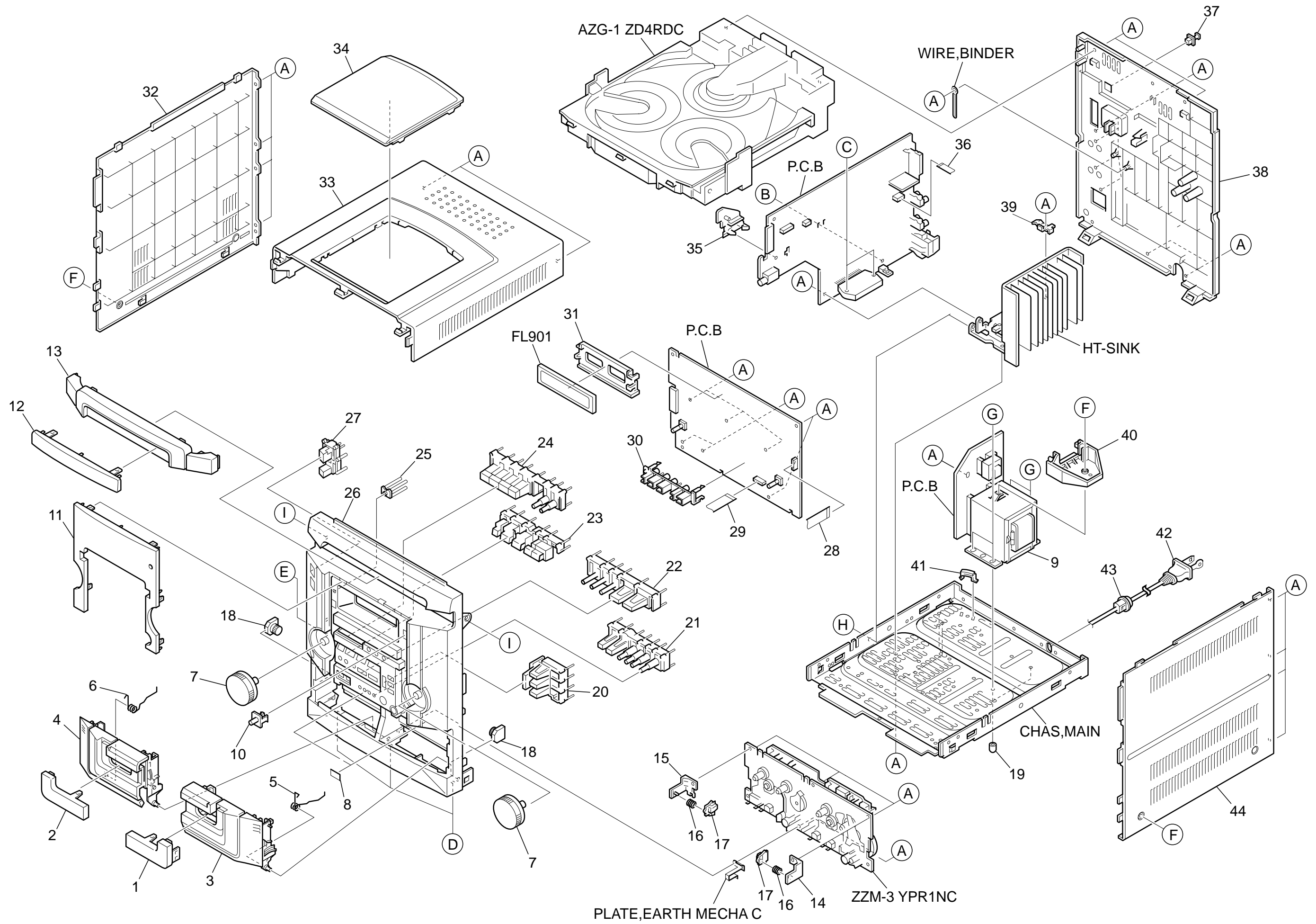

# MECHANICAL PARTS LIST 1 / 1 (NSX-BL24E / BL34E) <HA>

REF. NO.	PART NO.	KANRI NO.	DESCRIPTION	REF. NO.	PART NO.	KANRI NO.	DESCRIPTION
1	8A-NF0-007-010		WINDOW,CASS 2	29	88-911-101-110		FF-CABLE,11P 1.25
2	8A-NF0-006-010		WINDOW,CASS 1	30	8A-NF0-201-010		GUIDE,OPE 1 WAY
3	8A-NF0-004-010		BOX,CASS 2	31	82-NF7-210-110		GUIDE,FL(*)
4	8A-NF0-003-010		BOX,CASS 1	32	8A-NF8-007-010		PANEL,LEFT V-2
5	8A-NF8-208-010		SPR-T,EJECT 2	33	8A-NF8-005-010		PANEL,TOP
6	8A-NF8-207-010		SPR-T,EJECT 1	34	8A-NF8-006-010		WINDOW,TOP
7	8A-NF0-016-010		KNOB,RTRY VOL	35	8A-NF8-206-010		HLDR,PWB M
8	81-532-080-010		LABEL, CASS. COMPT	36	88-906-251-110		FF-CABLE,6P 1.25
△	9	8A-NF9-614-010	PT,ANF-9 HR-HI<24EHASC>	37	84-ZG1-245-210		CAP,OPTICAL
△	9	8A-NF9-616-010	PT,ANF-9 LH-HI<34EHASC>	38	8A-NFX-005-110		CABI,REAR LH W/O SPEC
10	8A-NF0-056-010		LENS,REMOCON	39	8A-NF8-216-010		HLDR,IC C<24EHASC>
11	8A-NF0-005-010		WINDOW,DISP U	39	86-NF6-211-010		HLDR,IC T1.6<34EHASC>
12	8A-NF0-038-010		WINDOW,CD	40	8A-NF9-211-010		HLDR,PWB PT HI
13	8A-NF0-014-010		PANEL,TRAY	41	87-NF4-221-010		HLDR,CABLE
14	87-NF4-217-110		HLDR,LOCK 2	△	42	87-A80-105-010	AC CORD ASSY,AZ
15	87-NF4-216-010		HLDR,LOCK 1	43	87-085-185-010		BUSHING, AC CORD(E)
16	86-NF9-224-010		SPR-C,LOCK	44	8A-NF8-008-010		PANEL,RIGHT V-2
17	82-NF5-229-010		PLATE,LOCK	A	87-067-703-010		TAPPING SCREW, BVT2+3-10
18	8A-NF8-209-010		OIL-DMPR,120	B	87-NF4-224-010		S-SCREW,IT3B+3-8 CU
19	8Z-NB8-240-010		COVER, PL	C	87-067-581-010		TAPPING SCREW, BVT2+3-15
20	8A-NF0-025-010		KEY,ENTER	D	87-067-689-010		TAPPING SCREW, BVTT+3-8
21	8A-NF0-018-010		KEY,SYNC	E	87-723-096-410		QT2+3-10W/O SLOT BL
22	8A-NF0-019-010		KEY,CD	F	87-067-641-010		UTT2+3-8(W/O SLOT)BL
23	8A-NF0-010-010		KEY,ASSY OPE 1 WAY	G	87-078-191-010		S-SCREW,IT+4-10
24	8A-NF0-009-010		KEY,FUN	H	87-721-096-410		QT2+3-10 GLD
25	8A-NF0-021-010		REFLECTOR,ECO	I	87-721-097-410		QT2+3-12 GLD
26	8A-NF0-039-010		CABI,FR HASC1M 24E<24EHASC>				
26	8A-NF0-033-010		CABI,FR HASC2M 34E<34EHASC>				
27	8A-NF0-008-010		KEY,POWER				
28	88-913-301-110		FF-CABLE,13P-1.25				

## COLOR NAME TABLE

Basic color symbol	Color	Basic color symbol	Color	Basic color symbol	Color
B	Black	C	Cream	D	Orange
G	Green	H	Gray	L	Blue
LT	Transparent Blue	N	Gold	P	Pink
R	Red	S	Silver	ST	Titan Silver
T	Brown	V	Violet	W	White
WT	Transparent White	Y	Yellow	YT	Transparent Yellow
LM	Metallic Blue	LL	Light Blue	GT	Transparent Green
LD	Dark Blue	DT	Transparent Orange	GM	Metallic Green
YM	Metallic Yellow	DM	Metallic Orange		

TAPE MECHANISM EXPLODED VIEW 1 / 1

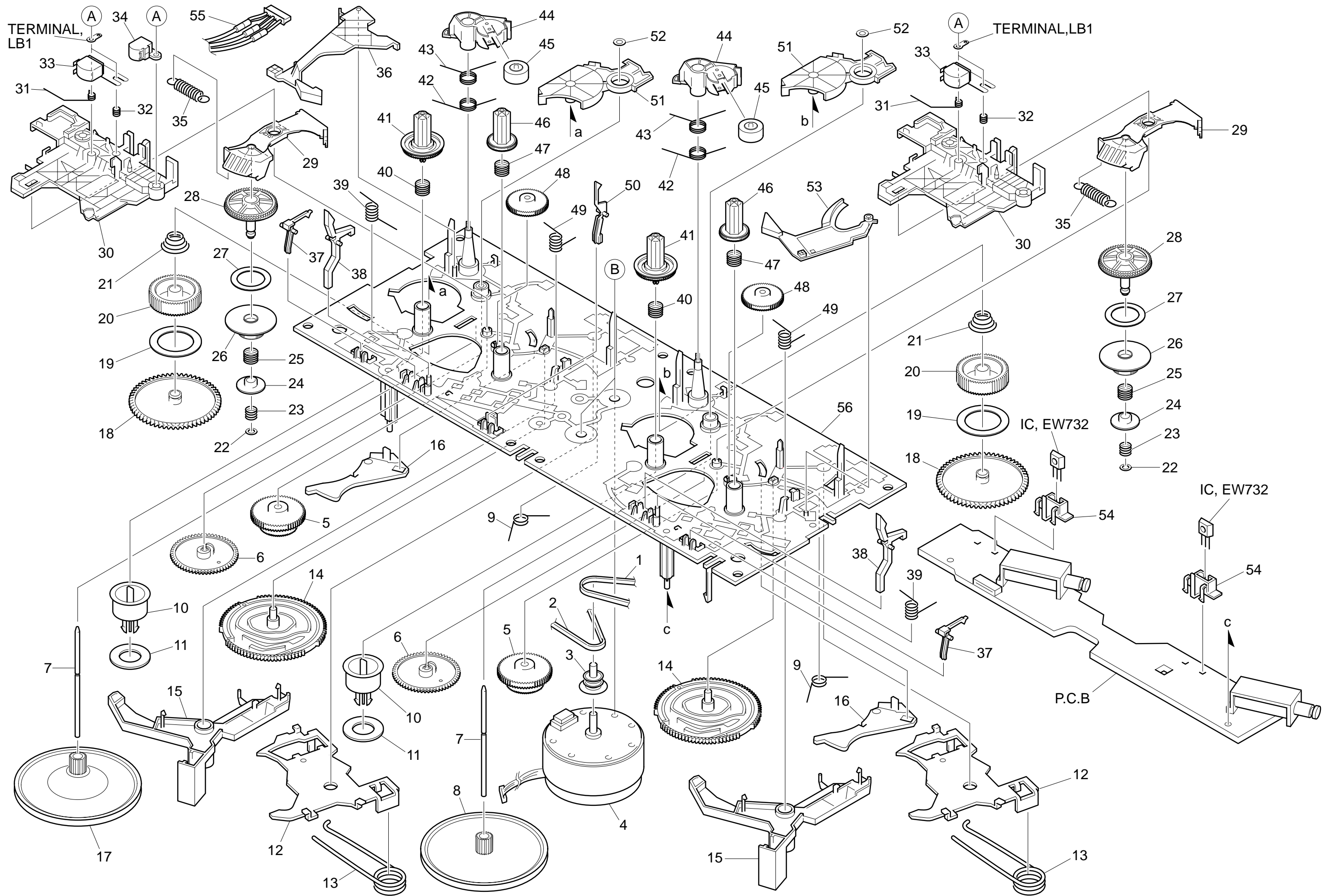

# TAPE MECHANISM PARTS LIST 1 / 1

REF. NO.	PART NO.	KANRI NO.	DESCRIPTION	REF. NO.	PART NO.	KANRI NO.	DESCRIPTION
1	8Z-ZM3-227-010		BELT,MAIN M3	31	8Z-ZM3-233-010		SPR-T,BRG M3
2	8Z-ZM3-235-010		BELT,MAIN L	32	84-ZM2-227-310		SPR-C,AZIMUTH
3	8Z-ZM1-235-010		PULLEY,MOT	33	87-A90-403-110		HEAD,RPH MS15R
4	87-045-347-010		MOT,SHU2L 70	34	87-A90-404-010		HEAD,EH LE15B
5	8Z-ZM1-232-010		GEAR,IDL FF/REW	35	8Z-ZM3-239-010		SPR-E,FR
6	8Z-ZM3-244-010		GEAR,CAM TD20	36	8Z-ZM3-211-010		LEVER,EJECT R
7	8Z-ZM3-242-010		SHAFT,CAP M3	37	8Z-ZM3-225-010		LEVER,STOP
8	8Z-ZM3-228-010		FLY-WHL,M3	38	8Z-ZM3-221-010		LEVER,CAS
9	8Z-ZM3-231-010		SPR-T,TRIG	39	8Z-ZM3-234-010		SPR-T,LVR CAS
10	8Z-ZM3-213-010		CLR,MG	40	8Z-ZM3-223-010		SPR-C,REEL R M3
11	82-ZM3-616-010		RING MAGNET 4	41	8Z-ZM1-225-110		GEAR,REEL R
12	8Z-ZM3-243-010		LEVER ASSY,HD UP	42	8Z-ZM3-240-010		SPR-T,T-UP M3
13	8Z-ZM3-238-010		SPR-T,HD UP	43	8Z-ZM3-237-010		SPR-T,PINCH M3
14	8Z-ZM3-219-010		GEAR,CAM M3	44	8Z-ZM3-215-010		LEVER,PINCH M3
15	8Z-ZM3-206-010		LEVER,TRIG	45	8Z-ZM1-261-110		ROLLER ASSY,PINCH
16	8Z-ZM3-209-010		LEVER,CAM FR	46	8Z-ZM1-226-010		GEAR,REEL L
17	8Z-ZM2-211-010		FLY-WHL,ZZM-2	47	8Z-ZM3-222-010		SPR-C,REEL L M3
18	8Z-ZM1-228-010		GEAR,SLIP T-UP B	48	8Z-ZM3-251-010		GEAR,IDL REW M3
19	8Z-ZM1-265-010		FELT,T-UP	49	8Z-ZM3-236-010		SPR-T,PLAY M3
20	8Z-ZM1-227-010		GEAR,SLIP T-UP A	50	82-ZM1-240-110		LVR,REC(*)
21	8Z-ZM1-251-110		SPR-C,T-UP SLIP	51	8Z-ZM3-216-010		LEVER,T-UP M3
22	8Z-ZM1-275-010		W-L,1,47-4-0.25	52	87-B10-301-010		W-L,1.63-3.2-05 SLIT
23	8Z-ZM1-257-010		SPR-C,F/R	53	8Z-ZM3-212-010		LEVER,EJECT L
24	8Z-ZM1-236-010		CLR,SLIP FF/REW	54	8Z-ZM3-214-010		HLDR,IC
25	8Z-ZM3-226-010		SPR-C,FR M3	55	86-ZM3-605-110		CONN ASSY,8P -RPB
26	8Z-ZM3-250-010		GEAR,SLIP F/R A M3	56	8Z-ZM3-203-010		CHAS ASSY,M3
27	8Z-ZM1-269-010		FELT,FF/REW 2	A	84-ZM2-242-010		S-SCREW,AZ1-2-6.4
28	8Z-ZM1-238-110		GEAR,SLIP FF/REW B 2	B	8Z-ZM2-220-110		V+2.6 ZZM-2
29	8Z-ZM3-220-010		LEVER,FR M3				
30	8Z-ZM3-205-010		LEVER,PLAY M3				

# SPEAKER DISASSEMBLY INSTRUCTIONS

## Type.1

Insert a flat-bladed screwdriver into the position indicated by the arrows and remove the panel. Remove the screws of each speaker unit and then remove the speaker units.

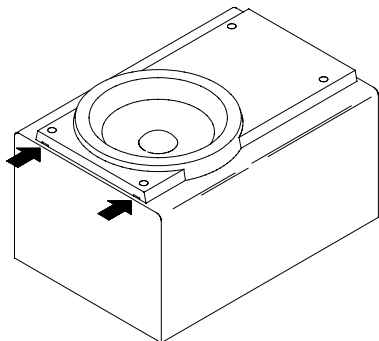

## Type.2

Remove the grill frame and four pieces of rubber caps by pulling out with a flat-bladed screwdriver. Remove the screws from hole where installed rubber caps. Insert a flat-bladed screwdriver into the position indicated by the arrows and remove the panel. Remove the screws of each speaker unit and then remove the speaker units.

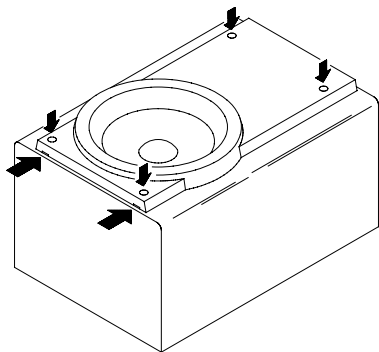

## Type.3

Insert a flat-bladed screwdriver into the position indicated by the arrows and remove the panel. Turn the speaker unit to counter-clockwise direction while inserting a flat-bladed screwdriver into one of the hollows around speaker unit, and then remove the speaker unit. After replacing the speaker unit, install it turning to clockwise direction until "click" sound comes out.

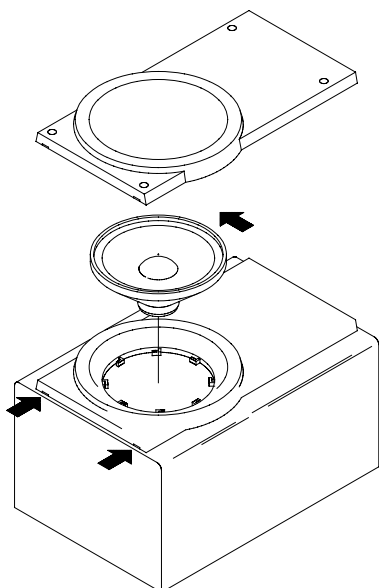

## Type.4

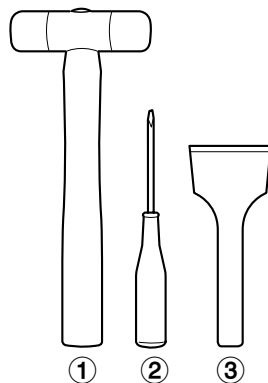

### TOOLS

- ① Plastic head hammer
- ② (⊖) flat head screwdriver
- ③ Cut chisel

## How to Remove the PANEL, FR

1. Insert the (⊖) flat head screwdriver tip into the gap between the PANEL, FR and the PANEL, SPKR. Tap the head of the (⊖) flat head screwdriver with the plastic hammer head, and create the clearance as shown in Fig-1.
2. Insert the cut chisel in the clearance, and tap the head of the cut chisel with plastic hammer as shown in Fig-2, to remove the PANEL, FR.
3. Place the speaker horizontally. Tap head of the cut chisel with plastic hammer as shown in Fig-3, and remove the PANEL, FR completely.

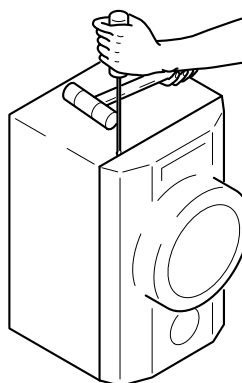

Fig-1

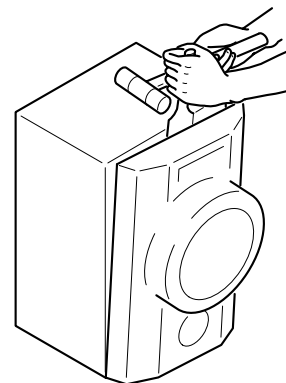

Fig-2

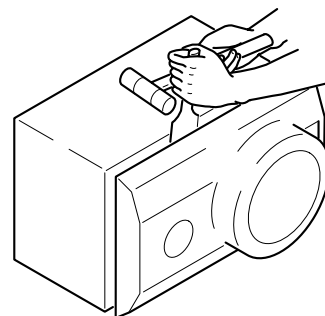

Fig-3

## How to Attach the PANEL, FR

Attach the PANEL, FR to the PANEL, SPKR. Tap the four corners of the PANEL, FR with the plastic hammer to fit the PANEL, FR into the PANEL, SPKR completely.



## SPEAKER PARTS LIST

(SX-NAJ25) <YUSL, YUSC9>

(SX-NBL25) <Y1SL, YLSL, YLSC9, YLSC3M, YUSC9>

REF. NO.	PART NO.	KANRI NO.	DESCRIPTION
1	8A-NSA-001-010		PANEL,FR
2	8A-NSA-003-010		GRILLE,FRAME ASSY
3	8A-NSK-602-010		SPKR,W 140
4	8A-NSK-606-010		SPKR,T 60
5	87-NSH-612-010		SPKR,CERAMIC ASSY
6	87-NS7-611-010		CORD,SPKR
7	8A-NSA-014-010		PANEL,DUCT
8	8Z-NSY-003-010		CORD,BUSH<YLSC3M>

## SPEAKER PARTS LIST

(SX-NBL42) <YLSL>

REF. NO.	PART NO.	KANRI NO.	DESCRIPTION
1	8A-NSX-001-010		PANEL,FR
2	8A-NSX-003-010		GRILLE,FRAME ASSY
3	8A-NSJ-602-010		SPKR,W 130
4	88-NS5-605-010		SPKR,T 60
5	87-NSH-612-010		SPKR,CERAMIC ASSY
6	87-NS7-611-010		CORD,SPKR

## SPEAKER PARTS LIST

(SX-R140) <YUSC>

REF. NO.	PART NO.	KANRI NO.	DESCRIPTION
1	8A-YS4-001-010		GRILLE,FRAME ASSY
2	8A-YS4-601-010		SPKR,80
3	8A-YS4-610-010		CORD,SPKR 3.5
4	87-NS7-611-010		SPKR,CORD
5	87-010-384-010		CAP,E 100-25 SME

## ACCESSORIES / PACKAGE LIST

REF. NO.	PART NO.	KANRI NO.	DESCRIPTION
1	8A-NF0-902-010		IB,LH(ESP)FM-BL24/BL34<24LH,34LH,24EHA,34EHA>
1	8A-NF0-903-010		IB,U(ESF)FM-AJ24<24U>
1	8A-NF0-922-010		IB,LH(P)CCE-BL24J<23LH>
2	87-006-225-010		ANT,LOOP ANT NC2<23LH>
2	87-A90-030-010		ANT,LOOP AM-NC C<EXCEPT 23LH>
3	87-043-115-010		FEEDER-ANT,FM
△ 4	87-A91-017-010		PLUG,CONVERSION JT-0476<24LH,34LH>
5	8Z-NF9-701-210		RC UNIT,ZAS02<23LH>
5	8Z-NF9-702-010		RC UNIT,ZAS02<EXCEPT 23LH>

**アイワ株式会社** 〒110-8710 東京都台東区池之端1-2-11 ☎03(3827)3111 (代表)  
**AIWA CO.,LTD.** 2-11, IKENOHATA 1-CHOME, TAITO-KU, TOKYO 110, JAPAN TEL:03 (3827) 3111