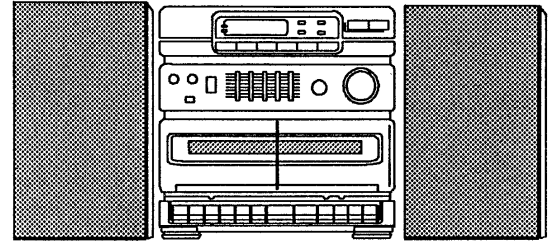

**AIWA®****NSX-D2  
XG-D2****SERVICE  
MANUAL**

COMPACT DISC STEREO SYSTEM

- BASIC TAPE MECHANISM: TN - 21ZSW

- TYPE. D (XG - D2)  
H, U, E (NSX - D2)

- 製品コード: 81CX4 - 0110  
81CX4 - 0210

SYSTEM	CASSIVER	SPEAKER	REMOTE CONTROLLER	COMPACT DISC
NSX - D2	XS - N2	SX - N2	RC - CN3	※DX - N3/ DX - NR3
XG - D2	XS - N2	SX - N2	RC - CN3	※DX - N3

※As to the service information of DX - N3/DX - NR3, see the individual service manual of DX - N3/DX - NR3.

※DX - N3は各専用のサービスマニュアルを参照して下さい。

サービス技術ニュース	
番号	連絡内容
G - -	
G - -	
G - -	

**アイワ株式会社**  
**AIWA Co., Ltd.**

**Tokyo Japan**

# SPECIFICATIONS

## チューナー部

<FM>	76MHz ~ 90MHz
受信周波数	75Ω フィーダーアンテナ
アンテナ	
<AM>	531kHz ~ 1,629kHz
受信周波数	AMワイヤーアンテナ
アンテナ	

## アンプ部

定格出力	7W + 7W (1kHz, 10%) EIAJ
入力感度 (負荷インピーダンス)	CD/LINE IN: 300mV (47kΩ)

## カセットデッキ部

トラック方式	4トラック2チャンネル
周波数特性	50~12,000 Hz (TYPE I)
SN比	50dB
ワウ・フラッター	0.2% (WRMS)
テープ速度	4.8cm/sec
	9.5cm/sec (倍速ダビング時)
モーター	DCサーボモーター (1)

## スピーカー部

型式	3ウェイ
インピーダンス	3.2Ω
最大入力	25W
使用スピーカー	ウーハー: 156mmコーン型 ミッドレンジ: 65mmコーン型 ツイーター: 27mmセラミック型
寸法	197(W)×328(H)×214(D)mm×2
重量	3.0kg×2

## 共通部

電源	AC100V 50/60Hz
消費電力	25W
本体寸法	265 (W)×250 (H)×230 (D)mm
本体重量	4.3kg
システム寸法	659 (W)×328 (H)×230 (D)mm
システム重量	10.3kg

● 外観及び仕様は予告なく変更する場合があります。

## TUNER SECTION

H model		
Band	Frequency range	Antenna
FM	87.5-108 MHz	Feeder
SW2	7.1-21.85 MHz	Wire
SW1	2.3-6.2 MHz	Wire/ Ferrite bar*
MW	531-1,602 kHz (9 kHz) 530-1,610 kHz (10 kHz)	

E model		
Band	Frequency range	Antenna
FM	87.5-108 MHz	Feeder
SW	5.95-15.6 MHz	Wire
MW	531-1,602 kHz	Wire/ Ferrite bar*
LW	146-281 kHz	

U model		
Band	Frequency range	Antenna
FM	87.5-108 MHz	Feeder
AM	530-1,710 kHz	Wire/ Ferrite bar*

(\* Built-in antenna.)

## AMPLIFIER SECTION

Power output	7 W + 7 W (4 ohms, EIAJ) Max.: 10 W + 10 W FTC RULE (U model) 5.3 watts per channel, Min. RMS at 3.2 ohms, from 80 Hz to 20 kHz, with no more than 3% distortion.
Input sensitivity (load impedance)	MIC: 2 mV (10 kohms) CD/LINE IN: 300 mV (47 kohms)
Power requirements	H, U: AC 110-120 V/220-240 V selectable, 50/60 Hz E: AC 220 V, 50/60 Hz
Power consumption	H : 30 W U : 25 W E : 35 W

## CASSETTE DECK SECTION

Track format	4 tracks, 2 channels
Frequency response	Normal tape: 50-12,000 Hz
Signal to noise ratio	50 dB (Normal tape)
Wow and flutter	0.2% (WRMS)
Tape speed	4.8 cm/sec (1 7/8 ips)
Rewind time	120 sec (C-60)
Fast forward time	120 sec (C-60)
Recording system	AC bias
Erase system	Magnetic erase
Motor	DC motor x 1
Heads	Record/playback head x 1 (deck 1) Erase head x 1 (deck 1) Playback head x 1 (deck 2)

## COMMON SECTION

Dimensions (WxHxD)	265 x 250 x 230 mm (10 1/2 x 9 7/8 x 9 1/8 in.)
Weight	4.3 kg (9.5 lbs) (Including batteries)

## SPEAKER

Cabinet type	3-way Bass reflex type
Speaker	156 mm (6 1/4 in.) cone type woofer 65 mm (2 5/8 in.) cone type mid-range 27 mm (1 1/8 in.) ceramic type tweeter
Impedance	3.2 ohms
Dimensions (WxHxD)	197 x 328 x 214 mm x 2 (7 7/8 x 13 x 8 1/2 in.)
Weight	3.0 kg x 2 (6.6 lbs x 2)

● Design and specifications are subject to change without notice.

# DISASSEMBLY INSTRUCTIONS

## 1. リヤキャビネットのはずし方 (Fig-1 参照)

- 1) ビス 9 本 (A×4, B×5) はずし、  
リヤキャビネットをはずす。

## 1. "Cabinet, Rear" Removal (See Figure - 1)

- 1) Remove 9 screws (A×4, B×5) and remove  
"Cabinet, Rear".

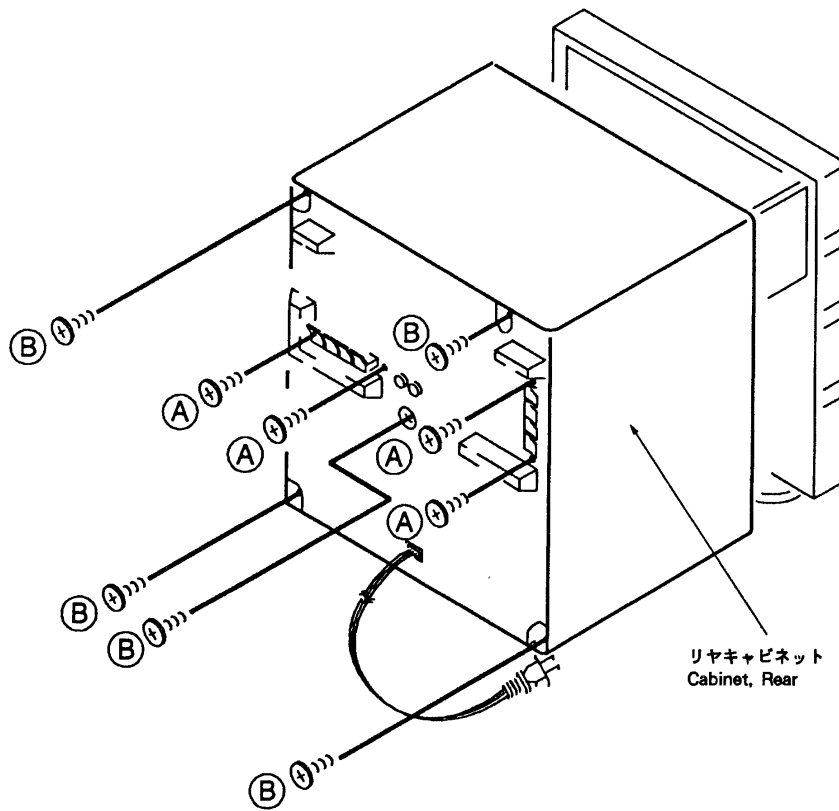

Fig - 1

## ■ ACCESSORIES/PACKAGE LIST

REF. NO.	PART NO.	DESCRIPTION	Q,TY	カンリ NO.
1	★S9-338-320-200	トリセツ (D)	1	1B
2	★S9-338-320-110	INSTRUCTION BOOKLET (U, EE, H)	1	

# ELECTRICAL MAIN PARTS LIST

REF. NO.	PART NO.	DESCRIPTION	カリNO.
===IC===			
	87-020-828-010	IC, BA3416BL	1C
	S4-038-220-000	IC, BA3822LS	1C
	S4-054-120-000	IC, BA5412	1E
	S4-245-550-000	IC, CD4555BE	1B
	81-504-628-010	IC, LA3220	1B
	S2-240-130-000	IC, MC14013BCP	1B
	87-020-356-010	IC, TA7358AP	1B
	S8-381-320-000	IC, TA8132AN	1H
	S8-493-070-000	IC, TC9307AF008	2M
===TRANSISTOR===			
	S9-011-800-180	FET, 2SK118R	1A
	89-311-623-010	トランジスタ 2SC1162C	1B
	S3-141-700-080	トランジスタ 2SC1417H, G	0E
	89-328-785-010	トランジスタ 2SC2878B	0E
	S3-045-800-030	トランジスタ 2SC458C	0E
	S7-805-000-020	トランジスタ PE8050B, C, D	0E
	S7-855-000-020	トランジスタ PE8550B, C	0E
===DIODE===			
	S0-240-010-000	ダイオード 1N4001B	0E
	82-135-799-010	ダイオード 1N4148	0E
	S0-254-010-000	ダイオード 1N5401BL	0E
	S0-001-010-000	ダイオード 1SV101	1B
	S0-001-490-000	ダイオード 1SV149B	1C
	S0-000-000-000	ダイオード CDG00	0E
	87-027-224-010	ツェナーダイオード 05AZ12VV	0E
	87-020-511-010	ツェナーダイオード 05AZ4.7V	0E
	S0-100-681-200	ツェナーダイオード 05AZ6.8V	0E
	S0-101-001-200	ツェナーダイオード 10V 1.2W	0E
===MAIN CIRCUIT BOARD SECTION===			
C305	★87-010-263-010	コンデンサ 100-10	0E
C306	★87-010-263-010	コンデンサ 100-10	0E
C311	★87-010-412-010	コンデンサ 10-25V	0E
C312	★87-010-412-010	コンデンサ 10-25V	0E
C313	★87-010-248-010	コンデンサ 220-10V	0E
C314	★88-333-210-010	コンデンサ 22-10V	0E
C315	★87-010-404-010	コンデンサ 4.7-50V	0E
C403	★87-010-404-010	コンデンサ 4.7-50V	0E
C404	★87-010-404-010	コンデンサ 4.7-50V	0E
C405	★87-010-374-010	コンデンサ 47-10V	0E
C406	★87-010-374-010	コンデンサ 47-10V	0E
C407	★87-010-412-010	コンデンサ 10-25V	0E
C408	★87-010-412-010	コンデンサ 10-25V	0E
C409	★87-010-412-010	コンデンサ 10-25V	0E
C410	★87-010-412-010	コンデンサ 10-25V	0E
C413	★87-010-374-010	コンデンサ 47-10V	0E
C414	★87-010-263-010	コンデンサ 100-10	0E
C415	★87-010-248-010	コンデンサ 220-10V	0E
C416	★87-010-221-010	コンデンサ 470-10V	0E
C423	★87-010-404-010	コンデンサ 4.7-50V	0E
C424	★87-010-404-010	コンデンサ 4.7-50V	0E
C602	★87-010-400-010	コンデンサ 0.47-50V	0E
C604	★87-010-400-010	コンデンサ 0.47-50V	0E
C605	★88-333-210-010	コンデンサ 22-10V	0E
C701	★87-015-962-010	コンデンサ 0.33-50V	0E
C702	★87-015-962-010	コンデンサ 0.33-50V	0E
C725	★87-010-412-010	コンデンサ 10-25V	0E
C726	★87-010-412-010	コンデンサ 10-25V	0E
C803	★87-015-965-010	コンデンサ 1-50	0E
C804	★87-015-965-010	コンデンサ 1-50	0E
C807	★87-010-380-010	コンデンサ 47-16V	0E
C808	★87-010-380-010	コンデンサ 47-16V	0E
C809	★87-010-112-010	コンデンサ 100-16V	0E
C812	★87-010-380-010	コンデンサ 47-16V	0E

REF. NO.	PART NO.	DESCRIPTION	カリリNO.
C813	★87-010-380-010	デンカイク 47-16V	0E
C814	★87-010-237-010	デンカイク 1000-16V	1A
C815	★87-010-237-010	デンカイク 1000-16V	1A
C818	★87-010-390-010	デンカイク 3300-25V	1C
C819	★87-010-380-010	デンカイク 47-16V	0E
C820	★87-010-380-010	デンカイク 47-16V	0E
C821	★87-010-380-010	デンカイク 47-16V	0E
C822	★87-010-380-010	デンカイク 47-16V	0E
C823	★87-010-112-010	デンカイク 100-16V	0E
C825	★87-010-112-010	デンカイク 100-16V	0E
C826	★87-010-412-010	デンカイク 10-25	0E
C906	★87-010-380-010	デンカイク 47-16V	0E
C908	★87-010-112-010	デンカイク 100-16V	0E
C910	★87-010-263-010	デンカイク 100-10	0E
C911	★87-010-112-010	デンカイク 100-16V	0E
C913	★87-010-221-010	デンカイク 470-10V	0E
C914	★87-010-265-010	デンカイク 33-16V	0E
J801	★S0-535-083-500	HP ジャック HTJ-035-08 (PHONES)	1B
J802	★S0-535-093-500	HP ジャック HTF-035-09 (MIC)	1A
J803	★S0-200-320-000	RCA ジャック (CD/LINE IN)	1B
J804	★S0-401-040-000	スピーカージャック (SPEAKERS)	1B
SW301	★S0-062-200-000	REC SW 6P2T (REC)	1A
SW401	★S2-300-711-000	スライド SW MSK2X3 RG (OSC)	1A
SW701	★S0-000-430-000	レバー SW FLPA43 (FUNCTION)	1C
SW702	★S2-203-000-000	PB SW PS22F03 (DUBBING SPEED)	1A
T401	★S0-036-300-100	IFT, 4A363R (B)	0E
VR401	★S1-030-850-000	SFR, 10K	0E
VR801	★S1-040-010-000	VR, 100KB (BALANCE)	1B
VR802	★S5-030-020-000	VR, 50KAX2 (VOLUME)	1B
VR901	★S2-020-850-000	SFR, 2K	0E
VR902	★S5-010-850-000	SFR, 500	0E
===TUNER CIRCUIT BOARD SECTION===			
BP201	★S1-000-080-010	BPF BFMMB8L	1B
C229	★87-010-221-010	デンカイク 470-10V	0E
C237	★87-010-404-010	デンカイク 4. 7-50V	0E
C241	★87-010-404-010	デンカイク 4. 7-50V	0E
C242	★87-010-404-010	デンカイク 4. 7-50V	0E
C248	★87-010-404-010	デンカイク 4. 7-50V	0E
C249	★87-010-404-010	デンカイク 4. 7-50V	0E
CF201	★S0-003-660-000	セラミックフィルタ C366-A	1B
CF202	★S0-004-500-000	セラミックフィルタ SFU450	1A
CF203	★S0-003-660-000	セラミックフィルタ C366-A	1B
CF204	★S6-004-560-000	セラミックレゾナータ CSB456F18	1B
J201	★S0-401-040-010	EXT. スピーカージャック (ANTENNA)	1B
L201	★S0-400-450-080	コイル FM 4T, 4. 5MM	0E
L202	★S0-600-450-080	コイル FM 6T, 4. 5MM	0E
L202	★S0-300-500-080	FM, COIL 3T, 5MM (H, U, E)	
L203	★S0-100-250-000	INDUCTOR 1UH (E, H)	
L204	★S0-190-411-000	SW, COIL 19:4 (H)	
L204	★S2-552-600-120	LW, COIL 255:26, 80 (E)	
L205	★S0-802-501-000	コイル MW 80:25	0E
	★S0-101-200-000	フェライト棒 10×120	1A
L206	★S0-045-700-000	IF, KM457 (H)	
L206	★S0-045-100-000	IFT, KM451R (E)	
L207	★S0-100-140-000	コイル 100UH	0E
L208	★S0-102-260-000	INDUCTOR 22UH (E, H)	
T200	★S0-045-000-110	IFT, KM450	0E
T201	★S0-012-700-100	IFT, 7A127N	0E
T202	★S0-103-800-100	IFT, 7A-1038R (H)	
T202	★S0-061-100-000	IFT, 1A611R (E)	
T203	★S0-061-200-100	IFT, 1A612R	0E
T204	★S0-045-800-000	IFT, KM458R (H)	
T204	★S0-045-200-000	IFT, KM452R (E)	
T205	★S0-022-400-100	IFT, 4A-224R	0E
TC201	★S2-101-690-000	トリマー TZ03T110FR169	1A
TC202	★S2-101-690-000	トリマー TZ03T110FR169 (H)	
TC202	★S2-001-690-000	トリマー TZ03R300FR169 (E)	

REF. NO.	PART NO.	DESCRIPTION	カテゴリ
TC203	★S2-101-690-000	トリム TZ03T110FR169	TRIMMER TZ03T110FR169
TC204	★S2-101-690-000		TRIMMER TZ03T110FR169 (H, E)
===EQ CIRCUIT BOARD SECTION===			
C703	★87-015-962-010	デンカコン 0.33-50V	CAP, ELECT 0.33-50V
C707	★87-015-965-010	デンカコン 1-50	CAP, ELECT 1-50
C711	★87-015-965-010	デンカコン 1-50	CAP, ELECT 1-50
C715	★87-015-962-010	デンカコン 0.33-50V	CAP, ELECT 0.33-50V
C719	★87-010-404-010	デンカコン 4.7-50V	CAP, ELECT 4.7-50V
C720	★87-010-404-010	デンカコン 4.7-50V	CAP, ELECT 4.7-50V
C728	★87-010-248-010	デンカコン 220-10V	CAP, ELECT 220 10V
VR701	★S5-030-000-220	スライダVR 50KAX2(100Hz)	VR, SLIDE 50KAX2(100Hz)
VR702	★S5-030-000-220	スライダVR 50KAX2(350Hz)	VR, SLIDE 50KAX2(350Hz)
VR703	★S5-030-000-220	スライダVR 50KAX2(1kHz)	VR, SLIDE 50KAX2(1kHz)
VR704	★S5-030-000-220	スライダVR 50KAX2(3.5kHz)	VR, SLIDE 50KAX2(3.5kHz)
VR705	★S5-030-000-220	スライダVR 50KAX2(10kHz)	VR, SLIDE 50KAX2(10kHz)
===CPU CIRCUIT BOARD SECTION===			
C103	★87-010-380-010	デンカコン 47-16V	CAP, ELECT 47-16V
C107	★87-010-400-010	デンカコン 0.47-50V	CAP, ELECT 0.47-50V
C114	★87-015-961-010	デンカコン 0.1-50	CAP, ELECT 0.1-50
C118	★88-333-210-010	デンカコン 22-10V	CAP, ELECT 22-10V
CY101	★S4-150-000-000	クォーツ発振子 KF-38R5	X'TAL KF-38R5
D212	★S0-024-202-050	LED, LN-242-RPH RED (FM MODE)	LED, LN-242-RPH RED (FM MODE)
D907	★S0-024-202-050	LED, LN-242-RPH RED (POWER)	LED, LN-242-RPH RED (POWER)
L101	★S0-100-140-000	コイル 100UH	INDUCTOR 100UH
L102	★S0-102-250-000	コイル 220UH	INDUCTOR 220UH
L105	★S0-100-140-000	コイル 100UH	INDUCTOR 100UH
LCD101	★S0-093-640-010	LCD DISPLAY BU9364(DISPLAY)	LCD DISPLAY BU9364(DISPLAY) (U)
LCD101	★S0-094-290-000		LCD DISPLAY BU9429(DISPLAY) (H, E)
SM1	★S0-083-000-000	タクト SW (FM MODE)	SW, TACT (FM MODE)
SM2	★S0-083-000-000	タクト SW (UP▲)	SW, TACT (UP▲)
SM3	★S0-083-000-000	タクト SW (SHIFT)	SW, TACT (SHIFT)
SM4	★S0-083-000-000	タクト SW (▼DOWN)	SW, TACT (▼DOWN)
SM5	★S0-083-000-000	タクト SW (3/8)	SW, TACT (3/8)
SM6	★S0-083-000-000	タクト SW (2/7)	SW, TACT (2/7)
SM7	★S0-083-000-000	タクト SW (1/6)	SW, TACT (1/6)
SM8	★S0-083-000-000	タクト SW (MEMORY)	SW, TACT (MEMORY)
SM9	★S0-083-000-000	タクト SW (5/10)	SW, TACT (5/10)
SM10	★S0-083-000-000	タクト SW (4/9)	SW, TACT (4/9)
SM11	★S0-083-000-000	タクト SW (BAND)	SW, TACT (BAND)
SM12	★S0-083-000-000	タクト SW (AUTO SCAN)	SW, TACT (AUTO SCAN)
SW101	★S2-200-511-000		SW, SLIDE SK22F03G5 (AM STEP) (H)
TB801	★S1-120-500-000	ランプ 12V, 50MMA	LAMP 12V, 50MMA
TB802	★S1-120-500-000	ランプ 12V, 50MMA	LAMP 12V, 50MMA
===POWER CIRCUIT BOARD SECTION===			
△	★S7-900-000-000	ヒューズホルダ	HOLDER, FUSE
C905	★87-010-389-000	デンカコン 2200-25V	CAP, ELECT 2200-25V
△F901	★S0-315-100-000	ヒューズ 3.15A 5-20MM (H, U)	FUSE 3.15A, 125V, 5-20MM (H, U)
===BATT-1 CIRCUIT BOARD SECTION===			
===BATT-2 CIRCUIT BOARD SECTION===			
===MISCELLANEOUS===			
△	★S0-001-200-000	ACコード	
△	★S1-171-200-010		AC CORD 117V APP (H)
△	★S1-171-200-000		AC CORD 117V UL/CSA (U)
△	★S2-201-200-000		AC CORD (EE) (E)
M1	S6-002-020-190	モーターデッキ EG539YD-9B	DECK, MOTOR EG539YD-9B
△PT101	★S5-393-380-300	パワートランス	
△PT101	★S5-693-380-700		POWER TRANSFORMER (HJ) (H)
△PT101	★S5-293-381-000		POWER TRANSFORMER (EE) (E)
△PT101	★S5-693-380-200		POWER TRANSFORMER (U)
SP101	S6-032-250-100	スピーカー 6" 3.2 25W (Lch)	SPEAKER 6" 3.2 25W (Lch)
SP102	S6-032-250-100	スピーカー 6" 3.2 25W (Rch)	SPEAKER 6" 3.2 25W (Rch)
SP103	★S2-580-010-100	スピーカー 2.5" 8 1W (Lch)	SPEAKER 2.5" 8 1W (Lch)
SP104	★S2-580-010-100	スピーカー 2.5" 8 1W (Rch)	SPEAKER 2.5" 8 1W (Rch)

REF. NO.	PART NO.		DESCRIPTION	カテゴリNO.
SP105	★S3-270-010-000	ブザー 27MM(L ch)	BUZZER 27MM(L ch)	1C
SP106	★S3-270-010-000	ブザー 27MM(R ch)	BUZZER 27MM(R ch)	1C
SW1	S6-401-011-520	リ-7 SW MSW-1541F(DECK 1)	SW, LEAF MSW-1541F(DECK 1)	1B
SW2	S6-401-011-610	リ-7 SW MSW-1115RK(DECK 1)	SW, LEAF MSW-1115RK(DECK 2)	1B
SW3	S6-401-011-520	リ-7 SW MSW-1541F(DECK 2)	SW, LEAF MSW-1541F(DECK 2)	1B
△SW901	★S1-200-000-010		SW, SLIDE SS-12J01M(AC VOLTAGE) (H, U)	
EH	S6-209-100-080	Eヘッド PH-K380-MS1-2A(DECK 1)	HEAD, E PH-K380-MS1-2A(DECK 1)	1A
PH	S6-201-010-750	Pヘッド RP-7442BS-0951(DECK 2)	HEAD, P RP-7442BS-0951(DECK 2)	1A
RPH	S6-201-010-750	Pヘッド RP-7442BS-0951(DECK 1)	HEAD, P RP-7442BS-0951(DECK 1)	1A

## TRANSISTOR ILLUSTRATION



E C B

2SC458

2SC1417

2SC2878

PE8050

PE8550



E C B

2SC1162



D G S

2SK118





**A MAIN C.B**

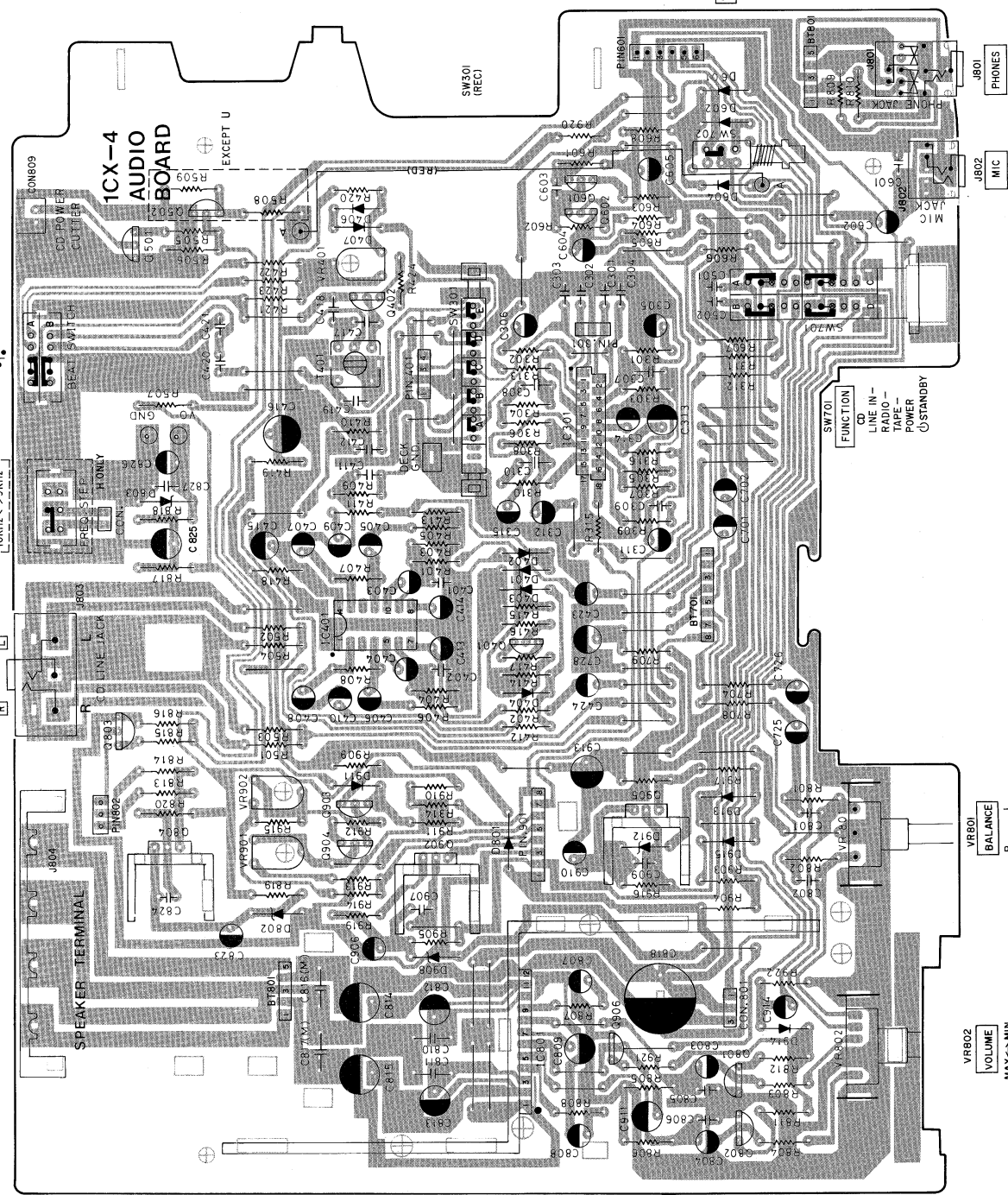

**C EQ C.B**

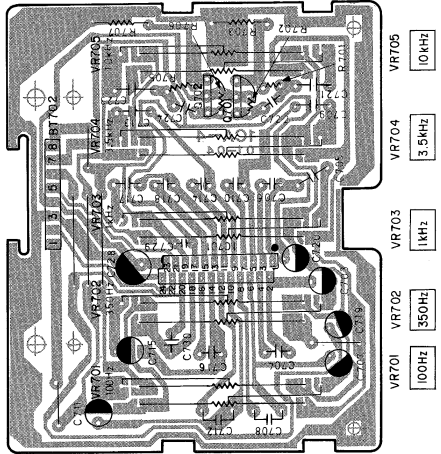

# ADJUSTMENT – 1 (D MODEL) < TUNER SECTION >

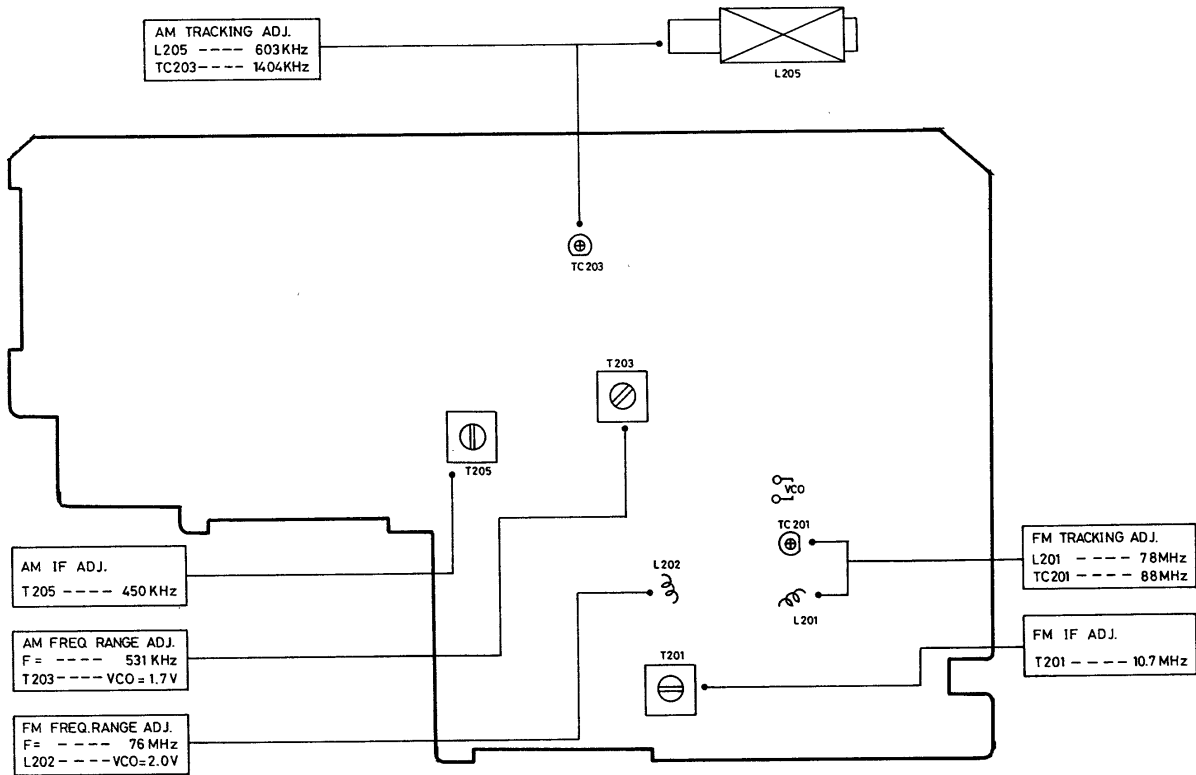

### IC 101 (TC 9307)

PIN'S NUMBER	1	2	3	4	5	6	7	8	9
MW	0	0	0	0	5.2	5.2	5.2	5.2	2.3
FM	0	0	0	0	5	5	5	5	2.1

### TC 9037

PIN'S NUMBER	10	26	27	28	29	30	31	32	33	34
MW	3.7	3.8		5.0	5.4	0	0	2.3	1	
FM	3.4	3.5		5.0	5.2	5.2	0	2.5	1	

### TC 9307

PIN'S NUMBER	35	36	37	38	39	40	41	42	43	44
MW	5.4	0	0	2.5	5.2	2.4	1.9	5.2	0	0
FM	5.2	2.5	0	0	5.0	2.7	1.8	5.0	0	0

### IC 102 (MC 14013)

PIN'S NUMBER	1	3	2,5	4,6,7,8,10	9,12,	11	13	14
AM	5.3	0	0	0	5.5	0	0	5.5
FM MONO	0.3	0	5.2	0	0	0	5.2	5.2
FM STEREO	5.2	0	0	0	0	0	5.2	5.2

### IC 202 (TA 8132)AN

PIN'S NUMBER	1	2	3	4	5	6	7	8	9	10
AM	5.1	5.1	5.2	4.8	5.2	4.5	0.5	0	5.2	
FM MONO	4.3	4.2	4.3	4.3	4.3	3.6	0.5	0	4.2	
FM STEREO	4.2	4.2	4.2	4.2	4.2	3.6	0.5	0	4.1	

### TA 8132 AN

PIN'S NUMBER	11	12	13	14	15	16	17	18	19	20
AM	4.1	0	1.0	1.0	4.6	5.2	4.9	0.7	1.3	4.6
FM MONO	4.0	0	1.0	1.0	4.0	4.0	4.2	0.7	1.0	3.3
FM STEREO	0.1	0	1.0	1.0	3.5	3.4	3.3	0.7	1.1	3.4

### TA 8132 AN

PIN'S NUMBER	21	22	23	24
AM	5.1	4.4	5.2	5.2
FM MONO	4.3	4.1	4.3	4.2
FM STEREO	4.2	4.1	4.2	4.1

### IC 201 (TA 7358)AP

PIN'S NUMBER	1	2	3	4	5	6	7	8	9
FM	0.8	1.5	4.0	1.5	0	3.9	3.1	3.9	3.9

IC 301 (BA 3416)

PIN'S NUMBER	1	2	3	4	5	6	7	8	9
DECK 1 LOW	0	0	0	0	0.6	0.6	0.1	0	0.1
DECK 1 HIGH	0	0	0	0	0.6	0.6	1.5	0	1.5
DECK 2 LOW	0	0	0	0	0.6	0.6	0.1	0	0.1
DECK 2 HIGH	0	0	0	0	0.6	0.6	1.5	0	1.5

BA 3416

PIN'S NUMBER	10	11	12	13	14	15	16	17	18
DECK 1 LOW	4.9	0.7	5.2	2.8	2.7	0	0	0	0.1
DECK 1 HIGH	4.7	0.7	5.0	2.6	2.6	0	0	0	0.1
DECK 2 LOW	4.8	1.9	5.2	2.7	2.6	0	0	0	1.6
DECK 2 HIGH	4.7	1.9	5.0	2.6	2.5	0	0	0	1.6

IC 401 (LA 3220)

PIN'S NUMBER	1	2	3	4	5	6	7
REC POSITION	0	2.9	5.1	2.9	2.9	0	0/0.1

LA 3220

PIN'S NUMBER	8	9	10	11	12	13	14
REC POSITION	2.9	0	2.9	2.9	5.1	2.9	5.8

IC 701 (BA 3822)

PIN'S NUMBER	1	2	3	4	5	6	7	8
CD POSITION	3.5	3.5	4.1	4.1	3.5	3.5	4.1	4.1

BA 3822

PIN'S NUMBER	9	10	11	12	13	14	15	16
CD POSITION	3.5	3.5	4.1	4.1	3.5	3.5	4.1	4.1

BA 3822

PIN'S NUMBER	17	18	19	20	21	22	23	24
CD POSITION	2.8	1.7	1.7	2.9	2.3	2.3	4.5	0

IC 801 (BA 5412)

PIN'S NUMBER	1	2	3	4	5	6
CD POSITION	18	9	15.5	0.6	0	6

BA 5412

PIN'S NUMBER	7	8	9	10	11	12
CD POSITION	16.4	0	0.6	15.5	9	0

BAND	Q 101 (K 118R)AN			Q 102 (C 458)AN			Q 103 (C 458)AN		
	G	D	S	B	C	E	B	C	E
MW 531kHz	1.7		2.1		1.7			1.7	
MW 1629kHz	8.6	12.1	9.0	1.0	8.6	0.6	0.6	8.6	0
FM 76 MHz	2.0		2.4		2.0			2.0	
FM 90 MHz	8.6	12.1	9.0	1.0	8.6	0.6	0.6	8.6	0

BAND	Q 201 (1417)			Q 202 (C 1417)			Q 209 (C 458)			Q 210 (8550)		
	B	C	E	B	C	E	B	C	E	B	C	E
FM 76.0 ---- 90.0 MHz	0.7	1.6	0	0.7	3.6	0	0.7	0.1	0	3.2	3.9	3.9

	Q 211 (8550)			Q 212 (8550)			Q 213 (8050)		
	B	C	E	B	C	E	B	C	E
AM MONO	4.4	5.1	5.1	4.5	5.1	5.1	0	0	0
FM MONO	3.6	4.3	4.3	4.6	4.0	4.3	0	0	0
FM STEREO	5.2	3.3	4.3	4.6	3.5	4.2	0	0	0

TAPE	Q 401 (C 458)			Q 903 (C 458)			Q 904 (8550)		
	B	C	E	B	C	E	B	C	E
LOW SPEED	0.1	0	0	2.2	10.3	1.6	10.8	11.4	11.4
HIGH SPEED	0.7	0	0	2.2	10.0	2.4	10.0	9.0	11.5

Q 402 (8050)			Q 601 (C 458)			Q 602 (C 458)			Q 701 (C 458)		
B	C	E	B	C	E	B	C	E	B	C	E
0.7	5.7	0.1	0.7	3.4	0.2	3.4	4.9	2.7	3.0	4.5	2.5

Q 702 (C 458)			Q 801 (C 458)			Q 802 (C 458)			Q 905 (C 1162)		
B	C	E	B	C	E	B	C	E	B	C	E
3.1	4.5	2.5	0	0	0	0	0	0	7.2	19.6	6.5

Q 902 (C 1162)			Q 906 (C 458)			Q 803 (8050)			Q 804 (C 1162)		
B	C	E	B	C	E	B	C	E	B	C	E
7.0	17.1	6.3	0	6.0	0	0.8	0.1	0	9.9	15.3	9.3

SCHEMATIC DIAGRAM - 1 (D MODEL)

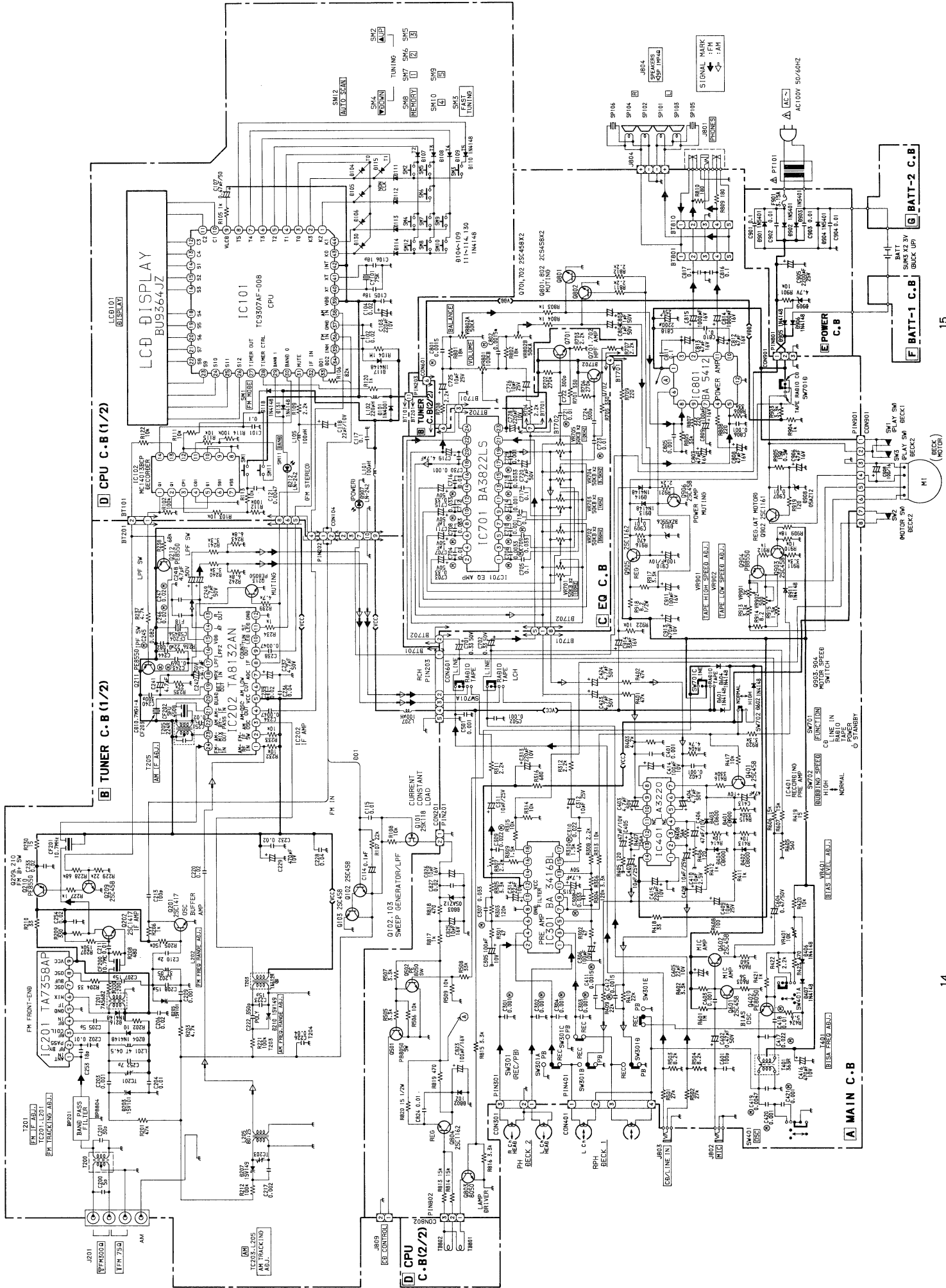



IC 301 (BA 3416)									
PIN'S NUMBER	1	2	3	4	5	6	7	8	9
DECK 1 LOW	0	0	0	0	0.6	0.6	0.1	0	0.1
DECK 2 HIGH	0	0	0	0	0.6	0.6	1.5	0	0.1
DECK 1 LOW	0	0	0	0	0.6	0.6	0.1	0	0.1
DECK 2 HIGH	0	0	0	0	0.6	0.6	1.5	0	1.5

BA 3416									
PIN'S NUMBER	10	11	12	13	14	15	16	17	18
DECK 1 LOW	5	0.7	5.3	2.5	2.6	0	0	0	0.1
DECK 2 HIGH	4.8	0.7	5.1	2.4	2.4	0	0	0	0.1
DECK 1 LOW	4.9	1.9	5.3	2.6	2.6	0	0	0	1.7
DECK 2 HIGH	4.8	1.9	5.1	2.4	2.5	0	0	0	1.7

IC 401 (LA 3220)							
PIN'S NUMBER	1	2	3	4	5	6	7
REC POSITION	0	2.9	5.1	2.9	2.9	0	0/0.1

LA 3220							
PIN'S NUMBER	8	9	10	11	12	13	14
REC POSITION	2.9	0	2.9	2.9	5.1	2.9	5.8

IC 701 (BA 3822)								
PIN'S NUMBER	1	2	3	4	5	6	7	8
CD POSITION	3.5	3.5	4.1	4.1	3.5	3.5	4.1	4.1

BA 3822								
PIN'S NUMBER	9	10	11	12	13	14	15	16
CD POSITION	3.5	3.5	4.1	4.1	3.5	3.5	4.1	4.1

BA 3822								
PIN'S NUMBER	17	18	19	20	21	22	23	24
CD POSITION	2.8	1.7	1.7	2.9	2.3	2.3	4.5	0

IC 801 (BA 5412)						
PIN'S NUMBER	1	2	3	4	5	6
CD POSITION (AC)	18	9	15.5	0.6	0	6

BA 5412 AN						
PIN'S NUMBER	7	8	9	10	11	12
CD POSITION	16.4	0	0.6	15.5	9	0

BAND	Q 101 (K 118R)			Q 102 (C 458)			Q 103 (458)		
	G	D	S	B	C	E	B	C	E
MW 531kHz	1.7	12.1	2.3	1.0	1.7	0.6	0.6	1.7	0
MW 1602kHz	8.5	12.1	9.1	1.0	8.5	0.6	0.6	8.5	0
FM 87.5kHz	2.8	12.1	3.3	0	2.8	0.6	0.6	2.8	0
FM 108MHz	8.9	12.1	9.4	1.0	8.9	0.6	0.6	8.9	0
SW 1 2.3MHz	2.5	12.1	3	1.0	2.5	0.6	0.6	2.5	0
SW 1 6.2MHz	8.5	12.1	8.6	1.0	8.5	0.6	0.6	8.5	0
SW 2 7.1MHz	1.7	12.1	2.2	1.0	1.7	0.6	0.6	1.7	0
SW 2 15.6MHz	9.3	12.1	9.8	1.0	9.3	0.6	0.6	9.3	0

	Q 203 (C 2878)			Q 204 (C 2878)			Q 205 (C 2878)		
	B	C	E	B	C	E	B	C	E
MW	0	0	0	0.7	0	0	0	0	0
FM	0	0	0	0	0	0	0	0	0
SW 1	0.7	0	0	0	0	0	0	0	0

	Q 206 (C 2878)			Q 207 (C 2878)			Q 205 (C 2078)		
	B	C	E	B	C	E	B	C	E
MW	0	5.0	5.0	5.8	5.0	5.0	0	5.0	5.0
FM									
SW 1	5.8	5.0	5.0	0	5.0	5.0	0	5.0	5.0
SW 2	0	5.0	5.0	0	5.0	5.0	5.8	5.0	5.0

BAND	Q 201 (1417)			Q 202 (C 1417)			Q 209 (C458)			Q 210 (8550)		
	B	C	E	B	C	E	B	C	E	B	C	E
FM 87.5 ----108 MHz	0.7	1.6	0	0.7	3.6	0	0.7	0.1	0	3.2	3.9	3.9

	Q 211 (8550)			Q 212 (8550)			Q 213 (8050)		
	B	C	E	B	C	E	B	C	E
AM MONO	4.4	5.1	5.1	4.5	5.1	5.1	0	0	0
FM MONO	3.6	4.3	4.3	4.6	4.0	4.3	0	0	0
FM STEREO	5.2	3.3	4.3	4.6	3.5	4.2	0	0	0

TAPE	Q401 (C 458)			Q 903 (C 458)			Q 904 (8550)		
	B	C	E	B	C	E	B	C	E
LOW SPEED	0.1	0	0	2.2	10.3	1.6	10.8	11.4	11.4
HIGH SPEED	0.7	0	0	2.2	10.0	2.4	10.0	9.0	11.5

Q 402 (8050)			Q 601 (C 458)			Q 602 (C 458)			Q 701 (C 458)		
B	C	E	B	C	E	B	C	E	B	C	E
0.7	5.7	0.1	0.7	3.4	0.2	3.4	4.9	2.7	3.0	4.5	2.5

Q 702 (C 458)			Q 801 (C 458)			Q 802 (C 458)			Q 905 (C 1162)		
B	C	E	B	C	E	B	C	E	B	C	E
3.1	4.5	2.5	0	0	0	0	0	0	7.2	19.6	6.5

Q 902 (C 1162)			Q 906 (C458)			Q 803 (8050)			Q 804 (C 1162)		
B	C	E	B	C	E	B	C	E	B	C	E
7.0	17.1	6.3	0	6.0	0	0.8	0.1	0	9.9	15.3	9.3



SCHEMATIC DIAGRAM - 3 (U MODEL)

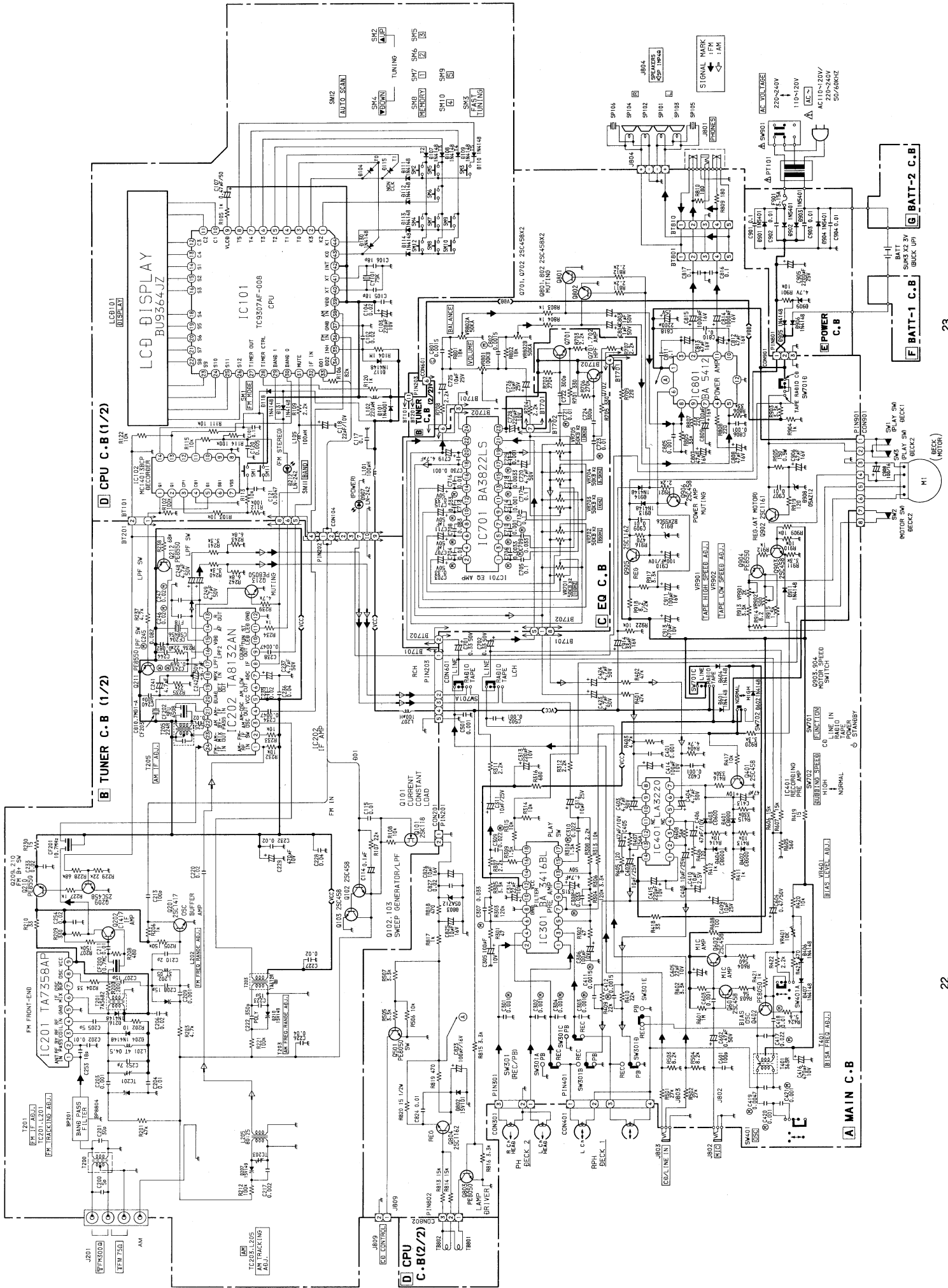



# ADJUSTMENT – 3 (U MODEL) < TUNER SECTION >

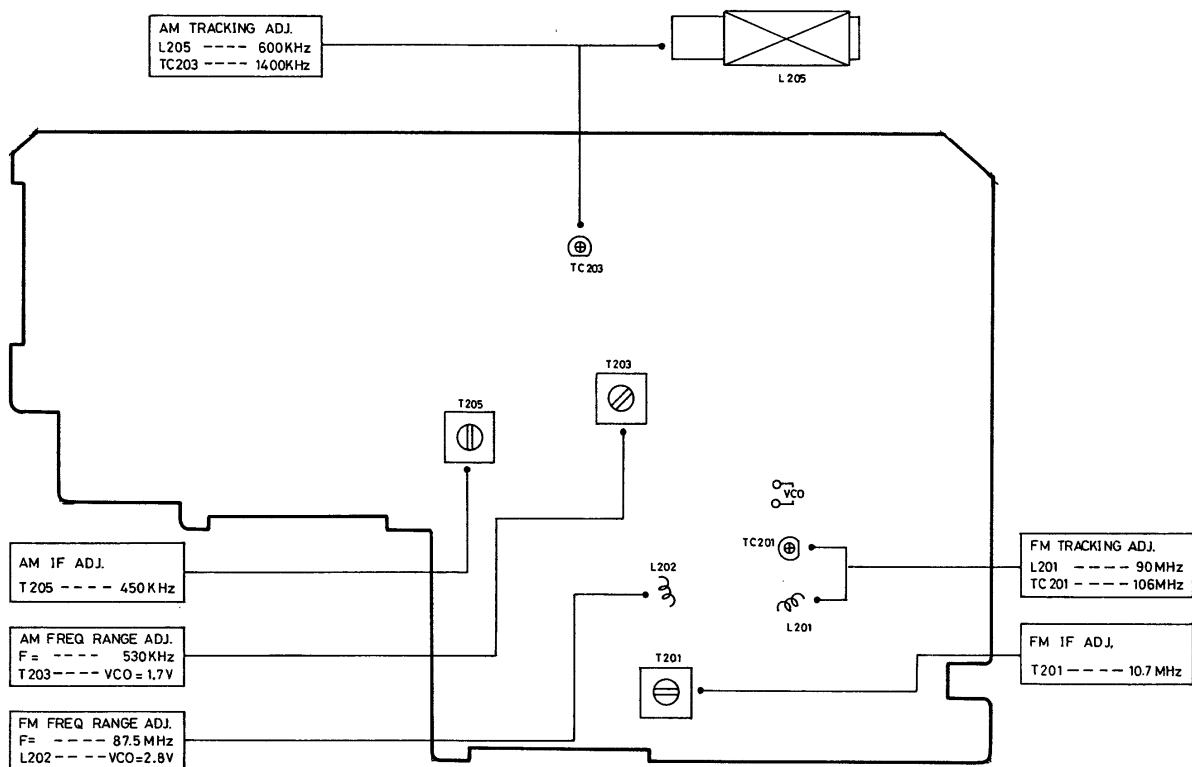

IC 101 (TC 9307)

PIN'S NUMBER	1	2	3	4	5	6	7	8	9
MW	0	0	0	0	5.2	5.2	5.2	5.2	2.3
FM	0	0	0	0	5	5	5	5	2.1

TC 9037

PIN'S NUMBER	10	26	27	28	29	30	31	32	33	34
MW	3.7	3.8		5.0	5.4	0	0	2.3	1	
FM	3.4	3.5		5.0	5.2	5.2	0	2.5	1	

TC 9307

PIN'S NUMBER	35	36	37	38	39	40	41	42	43	44
MW	5.4	0	0	2.5	5.2	2.4	1.9	5.2	0	0
FM	5.2	2.5	0	0	5.0	2.7	1.8	5.0	0	0

IC 102 (MC 14013)

PIN'S NUMBER	1	3	2,5	4,6,7,8,10	9,12,	11	13	14
AM	5.3	0	0	0	5.5	0	0	5.5
FM MONO	0.3	0	5.2	0	0	0	5.2	5.2
FM STEREO	5.2	0	0	0	0	0	5.2	5.2

IC 202 (TA 8132)AN

PIN'S NUMBER	1	2	3	4	5	6	7	8	9	10
AM	5.1	5.1	5.2	4.8	5.2	4.5	0.5	0	5.2	
FM MONO	4.3	4.2	4.3	4.3	4.3	3.6	0.5	0	4.2	
FM STEREO	4.2	4.2	4.2	4.2	4.2	3.6	0.5	0	4.1	

TA 8132 AN

PIN'S NUMBER	11	12	13	14	15	16	17	18	19	20
AM	4.1	0	1.0	1.0	4.6	5.2	4.9	0.7	1.3	4.6
FM MONO	4.0	0	1.0	1.0	4.0	4.0	4.2	0.7	1.0	3.3
FM STEREO	0.1	0	1.0	1.0	3.5	3.4	3.3	0.7	1.1	3.4

TA 8132 AN

PIN'S NUMBER	21	22	23	24
AM	5.1	4.4	5.2	5.2
FM MONO	4.3	4.1	4.3	4.2
FM STEREO	4.2	4.1	4.2	4.1

IC 201 (TA 7358)AP

PIN'S NUMBER	1	2	3	4	5	6	7	8	9
FM	0.8	1.5	4.0	1.5	0	3.9	3.1	3.9	3.9

IC 301 (BA 3416)

PIN'S NUMBER	1	2	3	4	5	6	7	8	9
DECK 1 LOW	0	0	0	0	0.6	0.6	0.1	0	0.1
DECK 1 HIGH	0	0	0	0	0.6	0.6	1.5	0	1.5
DECK 2 LOW	0	0	0	0	0.6	0.6	0.1	0	0.1
DECK 2 HIGH	0	0	0	0	0.6	0.6	1.5	0	1.5

BA 3416

PIN'S NUMBER	10	11	12	13	14	15	16	17	18
DECK 1 LOW	4.9	0.7	5.2	2.8	2.7	0	0	0	0.1
DECK 1 HIGH	4.7	0.7	5.0	2.6	2.6	0	0	0	0.1
DECK 2 LOW	4.8	1.9	5.2	2.7	2.6	0	0	0	1.6
DECK 2 HIGH	4.7	1.9	5.0	2.6	2.5	0	0	0	1.6

IC 401 (LA 3220)

PIN'S NUMBER	1	2	3	4	5	6	7
REC POSITION	0	2.9	5.1	2.9	2.9	0	0/0.1

LA 3220

PIN'S NUMBER	8	9	10	11	12	13	14
REC POSITION	2.9	0	2.9	2.9	5.1	2.9	5.8

IC 701 (BA 3822)

PIN'S NUMBER	1	2	3	4	5	6	7	8
CD POSITION	3.5	3.5	4.1	4.1	3.5	3.5	4.1	4.1

BA 3822

PIN'S NUMBER	9	10	11	12	13	14	15	16
CD POSITION	3.5	3.5	4.1	4.1	3.5	3.5	4.1	4.1

BA 3822

PIN'S NUMBER	17	18	19	20	21	22	23	24
CD POSITION	2.8	1.7	1.7	2.9	2.3	2.3	4.5	0

IC 801 (BA 5412)

PIN'S NUMBER	1	2	3	4	5	6
CD POSITION	18	9	15.5	0.6	0	6

BA 5412

PIN'S NUMBER	7	8	9	10	11	12
CD POSITION	16.4	0	0.6	15.5	9	0

BAND	Q 101 (K 118R)IAN			Q 102 (C 458)IAN			Q 103 (C 458)IAN		
	G	D	S	B	C	E	B	C	E
MW 530kHz	1.7		2.1		1.7			1.7	
MW 1710kHz	8.6	12.1	9.0	1.0	8.6	0.6	0.6	8.6	0
FM 87.5MHz	2.8		3.2		2.8			2.8	
FM 108MHz	8.6	12.1	9.0	1.0	8.6	0.6	0.6	8.6	0

BAND	Q 201 (1417)			Q 202 (C 1417)			Q 209 (C 458)			Q 210 (8550)		
	B	C	E	B	C	E	B	C	E	B	C	E
FM 87.5 ---- 108 MHz	0.7	1.6	0	0.7	3.6	0	0.7	0.1	0	3.2	3.9	3.9

	Q 211 (8550)			Q 212 (8550)			Q 213 (8050)		
	B	C	E	B	C	E	B	C	E
AM MONO	4.4	5.1	5.1	4.5	5.1	5.1	0	0	0
FM MONO	3.6	4.3	4.3	4.6	4.0	4.3	0	0	0
FM STEREO	5.2	3.3	4.3	4.6	3.5	4.2	0	0	0

TAPE	Q 401 (C 458)			Q 903 (C 458)			Q 904 (8550)		
	B	C	E	B	C	E	B	C	E
LOW SPEED	0.1	0	0	2.2	10.3	1.6	10.8	11.4	11.4
HIGH SPEED	0.7	0	0	2.2	10.0	2.4	10.0	9.0	11.5

Q 402 (8050)			Q 601 (C 458)			Q 602 (C 458)			Q 701 (C 458)		
B	C	E	B	C	E	B	C	E	B	C	E
0.7	5.7	0.1	0.7	3.4	0.2	3.4	4.9	2.7	3.0	4.5	2.5

Q 702 (C 458)			Q 801 (C 458)			Q 802 (C 458)			Q 905 (C 1162)		
B	C	E	B	C	E	B	C	E	B	C	E
3.1	4.5	2.5	0	0	0	0	0	0	12.0	17.2	11.3

Q 902 (C 1162)			Q 906 (C 458)			Q 803 (8050)			Q 804 (C 1162)		
B	C	E	B	C	E	B	C	E	B	C	E
7.0	17.1	6.3	0	6.0	0	0.8	0.1	0	9.9	15.3	9.3

# ADJUSTMENT - 4 (E MODEL) < TUNER SECTION >

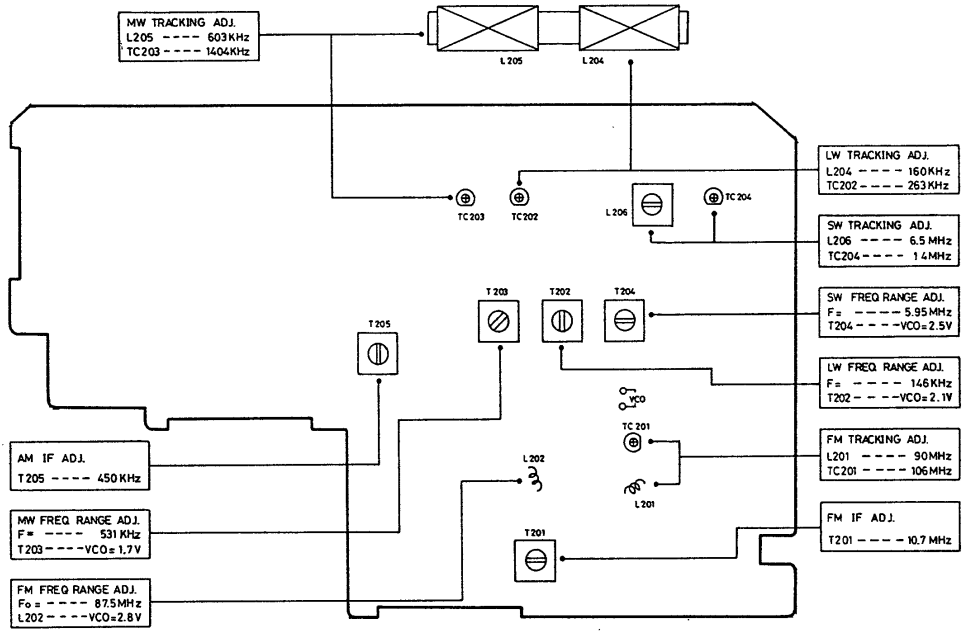

### IC 101 (TC 9307)

PIN'S NUMBER	1	2	3	4	5	6	7	8	9
MW	0	0	0	0	5.2	5.2	5.2	5.2	2.3
FM	0	0	0	0	5	5	5	5	2.1

### TC 9037

PIN'S NUMBER	10	26	27	28	29	30	31	32	33	34
MW	3.7	3.8		5.0	5.4	0	0	2.3	1	
FM	3.4	3.5		5.0	5.2	5.2	0	2.5	1	

### TC 9307

PIN'S NUMBER	35	36	37	38	39	40	41	42	43	44
MW	5.4	0	0	2.5	5.2	2.4	1.9	5.2	0	0
FM	5.2	2.5	0	0	5.0	2.7	1.8	5.0	0	0

### IC 102 (MC 14013)

PIN'S NUMBER	1	3	2,5	4,6,7,8,10	9,12,	11	13	14
AM	5.3	0	0	0	5.5	0	0	5.5
FM MONO	0.3	0	5.2	0	0	0	5.2	5.2
FM STEREO	5.2	0	0	0	0	0	5.2	5.2

### IC 202 (TA 8132)AN

PIN'S NUMBER	1	2	3	4	5	6	7	8	9	10
AM	5.1	5.1	5.2	4.8	5.2	4.5	0.5	0	5.2	
FM MONO	4.3	4.2	4.3	4.3	4.3	3.6	0.5	0	4.2	
FM STEREO	4.2	4.2	4.2	4.2	4.2	3.6	0.5	0	4.1	

### TA 8132 AN

PIN'S NUMBER	11	12	13	14	15	16	17	18	19	20
AM	4.1	0	1.0	1.0	4.6	5.2	4.9	0.7	1.3	4.6
FM MONO	4.0	0	1.0	1.0	4.0	4.0	4.2	0.7	1.0	3.3
FM STEREO	0.1	0	1.0	1.0	3.5	3.4	3.3	0.7	1.1	3.4

### TA 8132 AN

PIN'S NUMBER	21	22	23	24
AM	5.1	4.4	5.2	5.2
FM MONO	4.3	4.1	4.3	4.2
FM STEREO	4.2	4.1	4.2	4.1

### IC 201 (TA 7358)AP

PIN'S NUMBER	1	2	3	4	5	6	7	8	9
FM	0.8	1.5	4.0	1.5	0	3.9	3.1	3.9	3.9

**IC 301 (BA 3416)**

PIN'S NUMBER	1	2	3	4	5	6	7	8	9
DECK 1 LOW	0	0	0	0	0.6	0.6	0.1	0	0.1
DECK 1 HIGH	0	0	0	0	0.6	0.6	1.5	0	1.5
DECK 2 LOW	0	0	0	0	0.6	0.6	0.1	0	0.1
DECK 2 HIGH	0	0	0	0	0.6	0.6	1.5	0	1.5

**BA 3416**

PIN'S NUMBER	10	11	12	13	14	15	16	17	18
DECK 1 LOW	4.9	0.7	5.2	2.8	2.7	0	0	0	0.1
DECK 1 HIGH	4.7	0.7	5.0	2.6	2.6	0	0	0	0.1
DECK 2 LOW	4.8	1.9	5.2	2.7	2.6	0	0	0	1.6
DECK 2 HIGH	4.7	1.9	5.0	2.6	2.5	0	0	0	1.6

**IC 401 (LA 3220)**

PIN'S NUMBER	1	2	3	4	5	6	7
REC POSITION	0	2.9	5.1	2.9	2.9	0	0/0.1

**LA 3220**

PIN'S NUMBER	8	9	10	11	12	13	14
REC POSITION	2.9	0	2.9	2.9	5.1	2.9	5.8

**IC 701 (BA 3822)**

PIN'S NUMBER	1	2	3	4	5	6	7	8
CD POSITION	3.5	3.5	4.1	4.1	3.5	3.5	4.1	4.1

**BA 3822**

PIN'S NUMBER	9	10	11	12	13	14	15	16
CD POSITION	3.5	3.5	4.1	4.1	3.5	3.5	4.1	4.1

**BA 3822**

PIN'S NUMBER	17	18	19	20	21	22	23	24
CD POSITION	2.8	1.7	1.7	2.9	2.3	2.3	4.5	0

**IC 801 (BA 5412)**

PIN'S NUMBER	1	2	3	4	5	6
CD POSITION	18	9	15.5	0.6	0	6

**BA 5412**

PIN'S NUMBER	7	8	9	10	11	12
CD POSITION	16.4	0	0.6	15.5	9	0

BAND	Q 101 (K 118)IAN			Q 102 (C 458)AN			Q 103 (C 458)AN		
	G	D	S	B	C	E	B	C	E
MW 531kHz	1.7		2.1		1.7			1.7	
MW 1629kHz	8.6	12.1	9.0	1.0	8.6	0.6	0.6	8.6	0
FM 76 MHz	2.0		2.4		2.0			2.0	
FM 90 MHz	8.6	12.1	9.0	1.0	8.6	0.6	0.6	8.6	0

BAND	Q 201 (1417)			Q 202 (C 1417)			Q 209 (C 458)			Q 210 (8550)		
	B	C	E	B	C	E	B	C	E	B	C	E
FM 76.0 ---- 90.0 MHz	0.7	1.6	0	0.7	3.6	0	0.7	0.1	0	3.2	3.9	3.9

	Q 211 (8550)			Q 212 (8550)			Q 213 (8050)		
	B	C	E	B	C	E	B	C	E
AM MONO	4.4	5.1	5.1	4.5	5.1	5.1	0	0	0
FM MONO	3.6	4.3	4.3	4.6	4.0	4.3	0	0	0
FM STEREO	5.2	3.3	4.3	4.6	3.5	4.2	0	0	0

TAPE	Q 401 (C 458)			Q 903 (C 458)			Q 904 (8550)		
	B	C	E	B	C	E	B	C	E
LOW SPEED	0.1	0	0	2.2	10.3	1.6	10.8	11.4	11.4
HIGH SPEED	0.7	0	0	2.2	10.0	2.4	10.0	9.0	11.5

Q 402 (8050)			Q 601 (C 458)			Q 602 (C 458)			Q 701 (C 458)		
B	C	E	B	C	E	B	C	E	B	C	E
0.7	5.7	0.1	0.7	3.4	0.2	3.4	4.9	2.7	3.0	4.5	2.5

Q 702 (C 458)			Q 801 (C 458)			Q 802 (C 458)			Q 905 (C 1162)		
B	C	E	B	C	E	B	C	E	B	C	E
3.1	4.5	2.5	0	0	0	0	0	0	7.2	19.6	6.5

Q 902 (C 1162)			Q 906 (C 458)			Q 803 (8050)			Q 804 (C 1162)		
B	C	E	B	C	E	B	C	E	B	C	E
7.0	17.1	6.3	0	6.0	0	0.8	0.1	0	9.9	15.3	9.3







# MECHANICAL PARTS LIST

REF. NO.	PART NO.	DESCRIPTION	Q'TY	カンリ NO.
1-1	★S9-238-010-200	フロントパネル	PANEL, FRONT (U)	1 1H
1-1	★S9-238-010-300		PANEL, FRONT (H, E)	1 1H
1-2	★S9-238-070-000	ボリュームノブ	KNOB, VOLUME	1 OE
1-3	★S9-238-080-000	バランスノブ	KNOB, BALANCE	1 OE
1-4	★S9-238-030-000	カセットドアブタ	LID, CASSETTE DOOR	2 1A
1-5	★S9-238-440-000	カセットドアスプリング	SPRING, CASSETTE DOOR	2 OE
1-6	★S9-238-050-200	カセットドアカバー R	COVER, CASSETTE DOOR R	1 1B
1-7	★S9-238-550-100	カセットドアレンズ R	LENS, CASSETTE DOOR R	1 OE
1-8	★S9-238-560-100	カセットドアレンズ L	LENS, CASSETTE DOOR L	1 OE
1-9	★S9-238-040-200	カセットドアカバー L	COVER, CASSETTE DOOR L	1 1B
1-10	★S9-238-280-000	AIWAロゴ	LOGO, AIWA	3 OE
1-11	★S9-238-060-000	ギヤ	GEAR	2 OE
1-12	★S9-338-140-100	ファンクションコントロールレンズ	LENS, FUNCTION CONTROL (U, E)	1 1A
1-12	★S9-338-140-200		LENS, FUNCTION CONTROL (H)	1 1A
1-13	★S9-338-060-000	LCDライトレンズ	LENS, LCD LIGHT	1 OE
1-14	★S9-338-050-000	LCDブラケット	BRACKET, LCD	1 OE
1-15	★S2-500-000-000	バーアンテナホルダー	HOLDER, BAR ANTENNA	2 OE
1-16	★S0-101-200-000	フェライトバー 10-120	BAR, FERRITE 10-120	1 1A
1-17	---	PCBフィクスト	FIXED, P. C. B	1
1-18	★S9-238-260-000	ファンクショントグルノブ	KNOB, FUNCTION TOGGLE	1 OE
1-19	★S9-238-270-000	ダビングプッシュボタン	BUTTON, DUBBING PUSH	1 OE
1-20	---	ヒートシンク	HEAT SINK	3
1-21	---	ヒートシンク	HEAT SINK	1
1-22	★S9-238-140-000	EQノブ	KNOB, EQ	5 OE
1-23	★S9-238-130-000	スライドボリュームブラケット	BRACKET, SLIDE VOLUME	1 OE
1-24	★S9-238-460-000	RECORDプッシャー	PUSHER, RECORD	1 OE
1-25	★S9-238-470-000	レコードプッシュホルダー	HOLDER, RECORD PUSH	1 OE
1-26	★S9-238-480-000	RECORDプッシャーロッド	ROD, RECORD PUSHER	1 OE
1-27	★S9-238-220-000	PAUSEカセットノブ	KNOB, CASSETTE PAUSE	2 OE
1-28	★S9-238-210-000	S/Eカセットノブ	KNOB, CASSETTE S/E	2 OE
1-29	★S9-238-200-000	FFカセットノブ	KNOB, CASSETTE FF	2 OE
1-30	★S9-238-190-000	REWカセットノブ	KNOB, CASSETTE REW	2 OE
1-31	★S9-238-230-000	PLAYカセットノブ A	KNOB, CASSETTE PLAY A	1 OE
1-32	★S9-238-180-000	PLAYカセットノブ B	KNOB, CASSETTE PLAY B	1 OE
1-33	★S9-238-170-000	RECORDカセットノブ	KNOB, CASSETTE RECORD	1 OE
1-34	★S9-238-600-100	ラジオコントロールボタン	BUTTON, RADIO CONTROL	1 1A
1-35	★S9-238-160-200	バンドプリセットボタン	BUTTON, BAND PRESET (U, E)	1 1A
1-35	★S9-238-160-100		BUTTON, BAND PRESET (H)	1 1A



# EXPLODED VIEW - 2

REF. NO.	PART NO.	DESCRIPTION
A	87-741-104-410	SCREW VT2 + 3 - 30
B	87-741-096-410	SCREW VT2 + 3 - 10
C	S1-002-601-200	SCREW ST 2.6 - 12

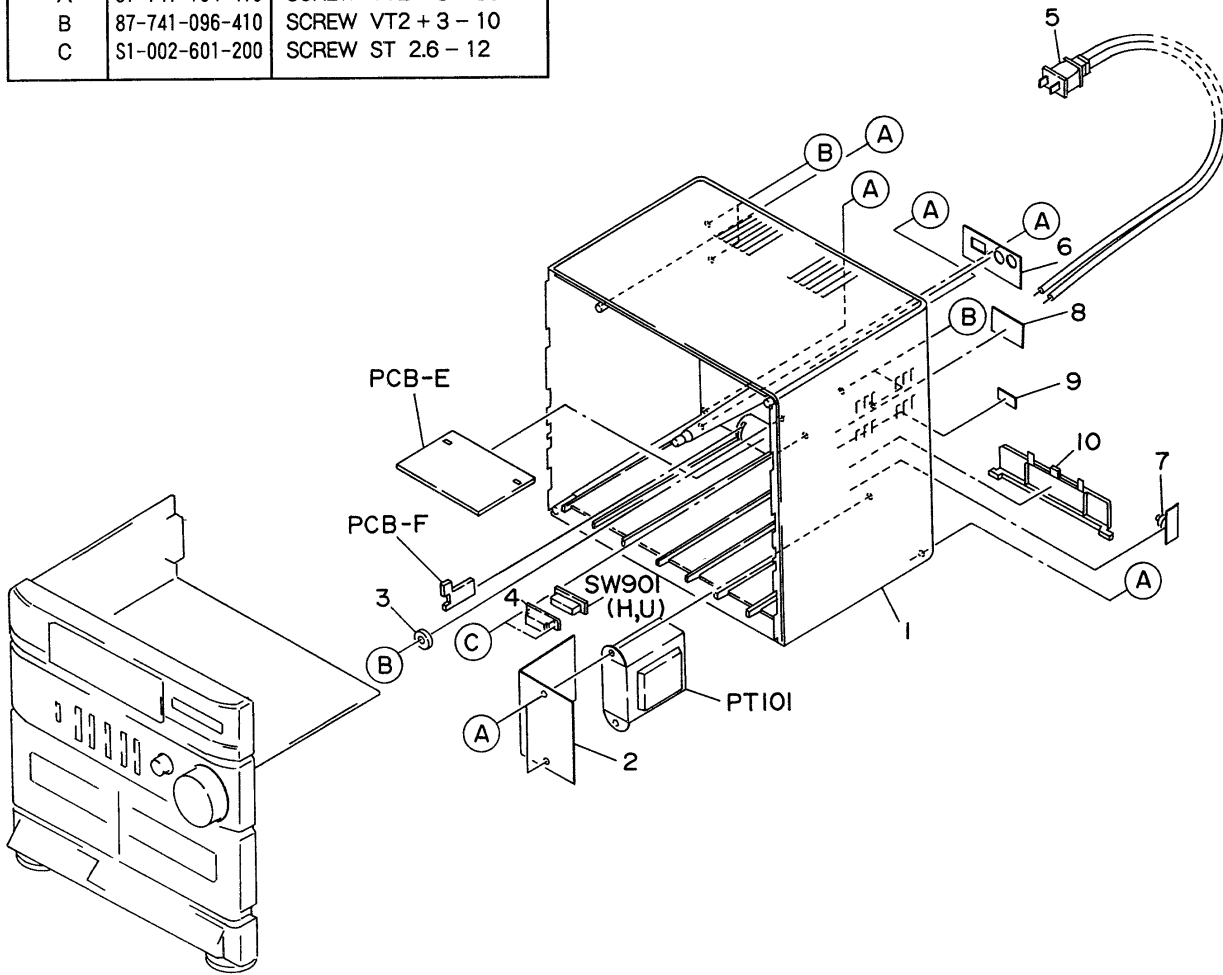

REF. NO.	PART NO.	DESCRIPTION	Q'TY	カンリ NO.
2-1	★S9-338-020-000	リヤキャビネット	1	2M
2-2	---	シールドプレート	1	
2-3	---	コードクランプワッシャー	1	
2-4	★S2-838-080-000	COVER, VOLTAGE SWITCH (H, U)	1	
2-5	★S0-001-200-000	ACコード	1	1D
2-5	★S1-171-200-000	CORD, AC (H)	1	
2-5	★S1-171-200-010	CORD, AC (U)	1	
2-5	★S2-201-200-000	CORD, AC (E)	1	
2-6	★S9-338-160-100	ジャックプレート	1	OE
2-6	★S9-338-150-100	PLATE, JACK (H)	1	
2-7	★S9-238-300-000	バッテリースプリング⊕⊖	1	OE
2-8	★S9-338-200-100	バックプレート	1	OE
2-8	★S9-338-200-700	PLATE, BACK (H)	1	
2-8	★S9-338-200-400	PLATE, BACK (U)	1	
2-8	★S9-338-200-400	PLATE, BACK (E)	1	
2-9	★S9-238-580-000	ボルテージスイッチプレート	1	OE
2-10	★S9-338-070-000	バッテリードア	1	OE

# EXPLODED VIEW - 3

REF. NO.	PART NO.	DESCRIPTION
A	S9-179-000-000	SCREW C TAPPING M2 - 3
B	S9-422-000-000	PW1.2 - 3.8 - 0.3 CUT
C	S9-679-000-000	SCREW P TAPPING M2 - 5
D	S9-999-180-090	SCREW CAMERA TAPPING M2 - 4.5
E	S9-922-000-000	SCREW M2 - 7 AZIMUTH
F	S9-115-000-000	SCREW ⊕ M2 - 3 BIND
G	S9-999-140-020	SCREW S CAMERA TAPPING M2 - 8
H	S9-786-000-000	PW 2 - 3.5 - 0.3
I	S9-999-200-410	SCREW PS TAPPING 2 - 3
J	S9-999-030-130	PW1.45 - 3.8 - 0.5 CUT
K	S9-004-000-000	SCREW M2 - 6

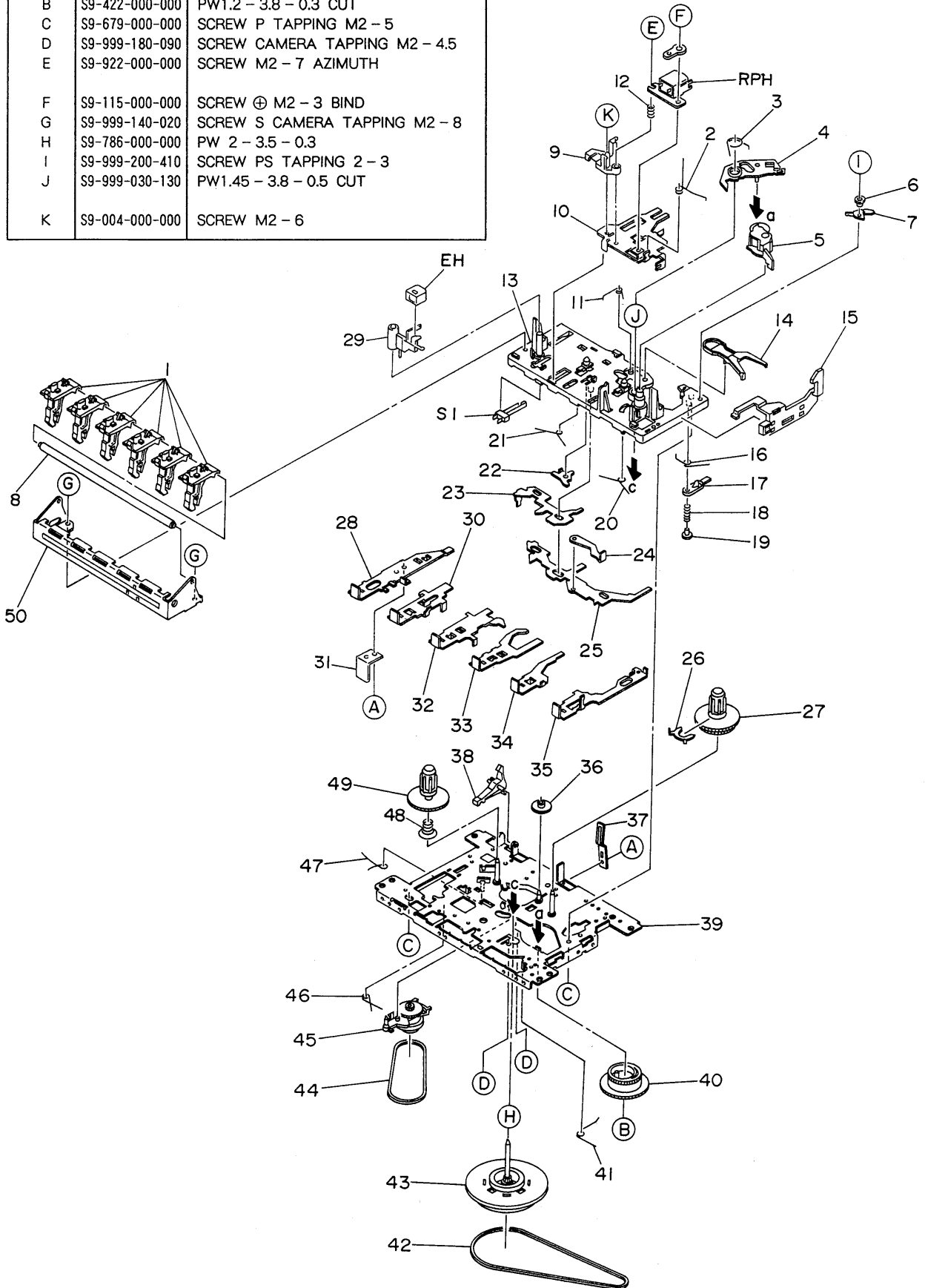

REF. NO.	PART NO.	DESCRIPTION	Q'TY	カンリ NO.
3-1	★S1-821-310-070	オペレーションレバー	6	0E
3-2	★S1-921-030-030	パネルPスプリング	1	0E
3-3	★S1-921-260-050	ギヤプレートスプリング	1	0E
3-4	★S1-921-265-020	ギヤプレートASSY	1	1B
3-5	★S1-921-043-090	ピンチローラーアームASSY	1	1C
3-6	★S1-921-140-370	Pアームカラー	1	0E
3-7	★S1-921-140-340	Pアーム	1	1A
3-8	★S1-829-310-030	ボタンレバーシャフト	1	0E
3-9	★S1-921-030-440	ヘッドベース	1	0E
3-10	★S1-921-030-110	ヘッドパネル	1	1A
3-11	★S1-921-140-180	Mスプリング, コントロール	1	0E
3-12	★S1-821-030-070	アジマススプリング	1	0E
3-13	★S1-921-143-010	ベースASSY	1	1C
3-14	★S1-921-260-040	センシングレバー	1	0E
3-15	★S1-921-130-020	イジェクトスライドレバー	1	0E
3-16	★S1-921-141-3A0	Pスプリング, コントロール	1	0E
3-17	★S1-921-140-550	PAUSEレバー E	1	0E
3-18	★S1-921-140-120	PAUSEレバースプリング	1	0E
3-19	★S1-921-140-110	PAUSEストッパー	1	0E
3-20	★S1-921-140-150	ボタンレバースプリング B	1	0E
3-21	★S1-921-140-140	ボタンレバースプリング A	1	0E
3-22	★S1-921-140-200	PRストッパー	1	0E
3-23	★S1-921-140-090	スイッチサドウ	1	0E
3-24	★S1-821-011-590	Eキックレバー	1	0E
3-25	★S1-921-140-080	プッシュボタンサドウ	1	0E
3-26	★S1-921-050-060	センサー	1	0E
3-27	★S1-921-053-030	テイクアップリールASSY	1	1F
3-28	★S1-921-140-220	RECボタンレバー	1	0E
3-29	★S1-921-030-050	MGアーム	1	0E
3-30	★S1-921-140-230	PLAYボタンレバー	1	0E
3-31	★S1-510-020-020	RECスプリングプレート	1	0E
3-32	★S1-921-140-240	REWボタンレバー	1	0E
3-33	★S1-921-140-250	FFボタンレバー	1	0E
3-34	★S1-921-140-260	STOPボタンレバー	1	0E
3-35	★S1-921-140-610	PAUSEボタンレバー	1	0E
3-36	★S1-821-100-700	FFギヤ	1	0E
3-37	★S1-829-100-010	バックスプリング	1	0E
3-38	★S1-821-100-690	RECセフティレバー	1	0E
3-39	---	シャーシASSY	1	-
3-40	★S1-921-260-020	カムギヤ	1	0E
3-41	★S1-921-140-160	サドウEスプリング	1	0E
3-42	★S1-921-090-240	メインベルト	1	1C
3-43	★S1-921-093-030	フライホイールASSY	1	1F
3-44	★S1-921-070-030	RFベルト	1	1C
3-45	★S1-921-073-020	RFクラッチASSY	1	1F
3-46	★S1-921-140-170	PSレバースプリング	1	0E
3-47	★S1-921-140-210	RECボタンレバースプリング	1	0E
3-48	★S1-829-100-100	バックテンションスプリング	1	0E
3-49	★S1-921-053-040	サプライリールASSY	1	1E
3-50	★S1-821-310-060	ボタンSフレーム	1	1B

# EXPLODED VIEW - 4

REF. NO.	PART NO.	DESCRIPTION
A	S9-179-000-000	SCREW C TAPPING M2 - 3
B	S9-180-000-000	SCREW C TAPPING M2 - 4
C	S9-679-000-000	SCREW P TAPPING M2 - 5
D	S9-999-180-090	SCREW CAMERA TAPPING M2 - 4.5
E	S9-004-000-000	SCREW M2 - 6
F	S9-115-000-000	SCREW ⊕ M2 - 3 BIND
G	S9-922-000-000	SCREW M2 - 7 AZIMUTH
H	S9-182-000-000	SCREW C TAPPING M2 - 3
I	S9-422-000-000	PW1.2 - 3.8 - 0.3 CUT
J	S9-999-030-130	PW1.45 - 3.8 - 0.5 CUT
K	S9-786-000-000	PW2 - 3.5 - 0.3
L	S9-999-140-020	SCREW S CAMERA TAPPING M2 - 8
M	S9-999-200-410	SCREW PS TAPPING 2 - 3

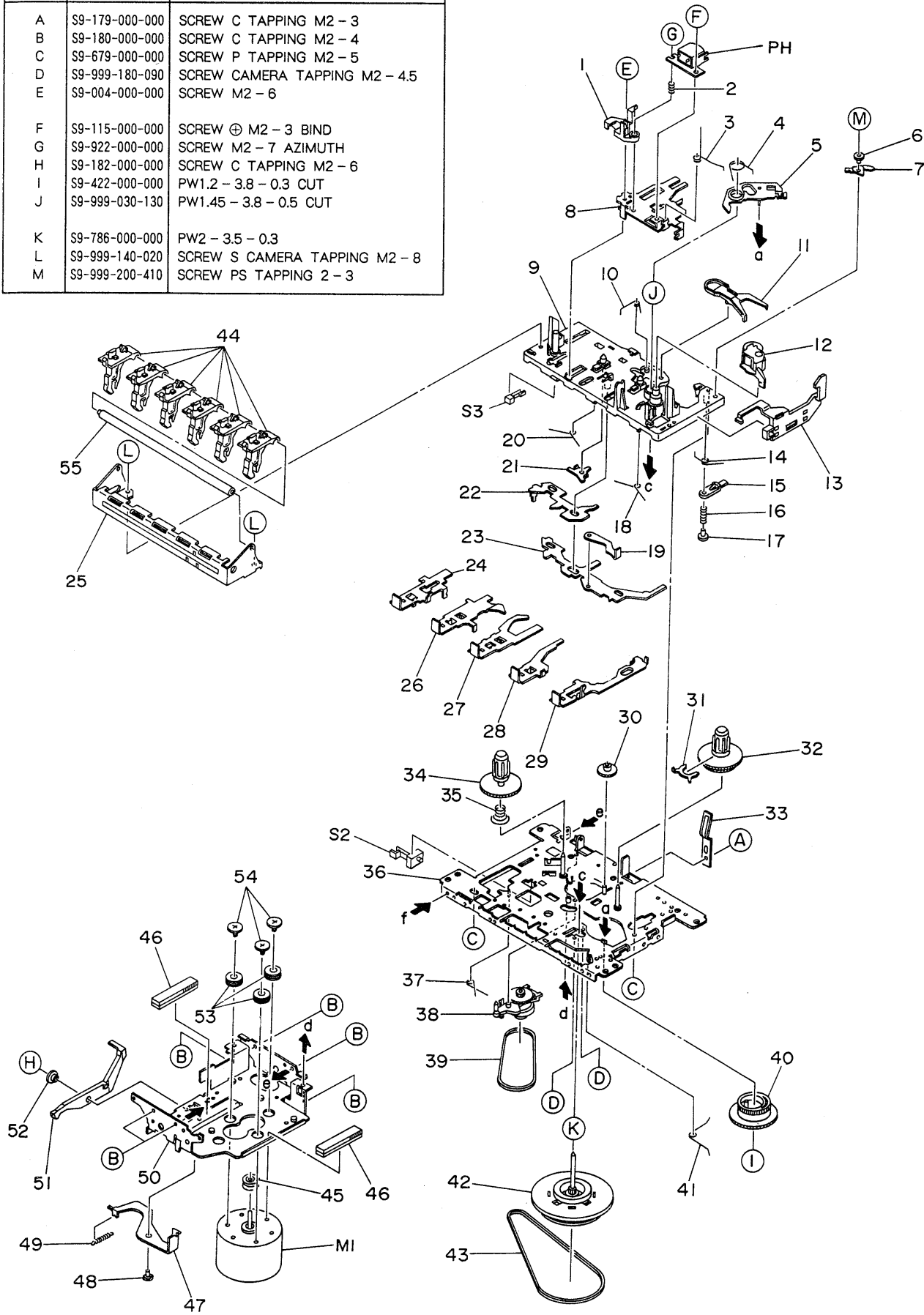

REF. NO.	PART NO.	DESCRIPTION	Q'TY	カンリ NO.
4-1	★S1-921-030-4A0	ヘッドベース	1	0E
4-2	★S1-821-030-070	アジマススプリング	1	0E
4-3	★S1-921-030-030	パネルPスプリング	1	0E
4-4	★S1-921-260-050	ギヤプレートスプリング	1	0E
4-5	★S1-921-265-020	ギヤプレートASSY	1	1B
4-6	★S1-921-140-370	Pアームカラー	1	0E
4-7	★S1-921-140-340	Pアーム	1	1A
4-8	★S1-921-030-110	ヘッドパネル	1	1A
4-9	★S1-921-143-010	ベースASSY	1	1C
4-10	★S1-921-140-180	Mスプリング, コントロール	1	0E
4-11	★S1-921-260-040	センシングレバー	1	0E
4-12	★S1-921-043-090	ピンチローラーアームASSY	1	1C
4-13	★S1-921-130-020	イジェクトスライドレバー	1	0E
4-14	★S1-921-141-3A0	コントロールPスプリング	1	0E
4-15	★S1-921-140-550	PAUSEレバー E	1	0E
4-16	★S1-921-140-120	PAUSEレバースプリング	1	0E
4-17	★S1-921-140-110	PAUSEストッパー	1	0E
4-18	★S1-921-140-150	ボタンレバースプリング B	1	0E
4-19	★S1-821-011-590	Eキックレバー	1	0E
4-20	★S1-921-140-140	ボタンレバースプリング A	1	0E
4-21	★S1-921-140-200	PRストッパー	1	0E
4-22	★S1-921-140-090	スイッチサドウ	1	0E
4-23	★S1-921-140-080	PUSHボタンサドウ	1	0E
4-24	★S1-921-140-230	PLAYボタンレバー	1	0E
4-25	★S1-821-310-060	ボタンSフレーム	1	1B
4-26	★S1-921-140-240	REWボタンレバー	1	0E
4-27	★S1-921-140-250	FFボタンレバー	1	0E
4-28	★S1-921-140-260	STOPボタンレバー	1	0E
4-29	★S1-921-140-610	PAUSEボタンレバー	1	0E
4-30	★S1-821-100-700	FFギヤ	1	0E
4-31	★S1-921-050-060	センサー	1	0E
4-32	★S1-921-053-030	テイクアップリールASSY	1	1F
4-33	★S1-829-100-010	バックスプリング	1	0E
4-34	★S1-921-053-040	サプライリールASSY	1	1E
4-35	★S1-829-100-100	バックテンションスプリング	1	0E
4-36	---	シャーシASSY	1	-
4-37	★S1-921-140-170	PSレバースプリング	1	0E
4-38	★S1-921-073-020	RFクラッチASSY	1	1F
4-39	★S1-921-070-030	RFベルト	1	1C
4-40	★S1-921-260-020	カムギヤ	1	0E
4-41	★S1-921-140-160	サドウEスプリング	1	0E
4-42	★S1-921-093-040	フライホイールASSY	1	1F
4-43	★S1-921-090-240	メインベルト	1	1C
4-44	★S1-821-310-070	オペレーションレバー	6	0E
4-45	★S1-921-120-130	モータープーリー	1	0E
4-46	---	ボウシンマット	2	-
4-47	★S1-821-120-680	Pキックレバー A	1	1A
4-48	★S1-821-120-230	PKカラースクリュー A	1	0E
4-49	★S1-821-120-250	Pスプリング, キックレバー	1	1B
4-50	★S1-921-120-110	モーターブラケット	1	1B
4-51	★S1-921-120-090	Pキックレバー B	1	1B
4-52	★S1-821-120-650	カラー B	1	0E
4-53	★S1-820-130-060	モーターラバー	3	0E
4-54	★S1-821-120-020	モーターカラースクリュー	3	0E
4-55	★S1-829-310-030	ボタンレバーシャフト	1	0E

# EXPLODED VIEW-5

REF. NO.	PART NO.	DESCRIPTION
A	S1-203-002-510	WOOD SCREW 3-25
B	S0-403-501-200	SCREW ST 3.5-12
C	87-741-096-410	SCREW VT2+3-10

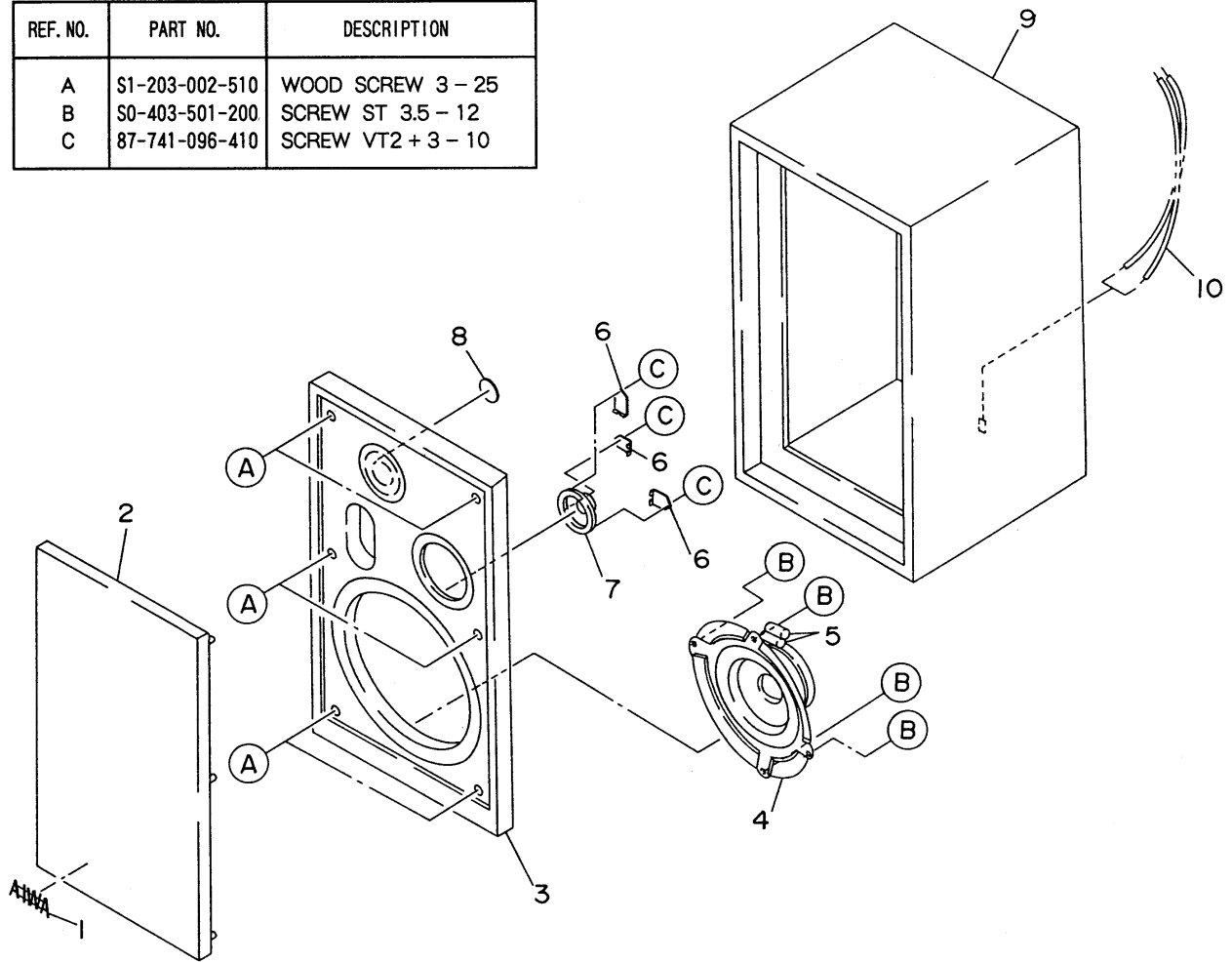

REF. NO.	PART NO.	DESCRIPTION	QTY	カンリ NO.
5-1	★S9-238-730-000	AIWAロゴ	1	0E
5-2	★S9-338-010-000	プラスチックパネル	1	1B
5-3	★S9-338-030-100	スピーカーパネル L	1	2A
5-3	★S9-338-040-100	スピーカーパネル R	1	2A
5-4	★S6-032-250-100	スピーカー	1	2M
5-5	★87-010-380-010	デンカイコン 47 μF	2	0E
5-6	---	スピーカークリップ	3	
5-7	★S2-580-010-100	スピーカー	1	1C
5-8	★S3-270-010-000	ブザー	1	0E
5-9	★S9-338-120-000	スピーカーボックス	1	2M
5-10	★S0-020-206-010	スピーカーワイヤー	1	1A

