

NSX-DR2 EZ (S)

NSX-DR3 EZ (S)

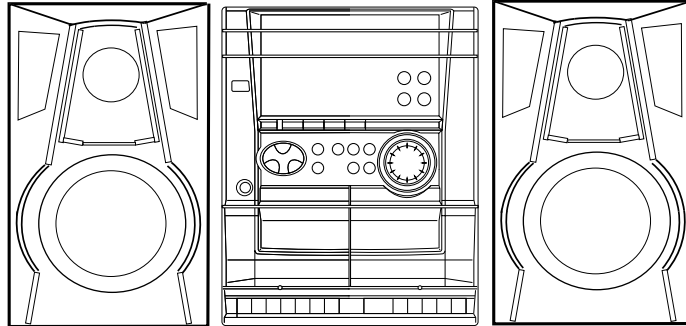

SERVICE MANUAL

COMPACT DISC
STEREO CASSEIVER

BASIC CD MECHANISM : AZG-1 ZA3RNM/ZA4RNC
BASIC TAPE MECHANISM : ZZM-2 PR1NM/PR1NC

SYSTEM	CD CASSEIVER	SPEAKER	REMOTE CONTROLLER
NSX-DR2	CX-NDR2	SX-NSZ7	RC-ZAS02
NSX-DR3	CX-NDR3	SX-NSZ5	

- If requiring information about the CD mechanism, see Service Manual of AZG-1, (S/M Code No. 09-001-335-3NC).

SPECIFICATIONS

Main unit

FM tuner section

Tuning range	87.5 MHz to 108 MHz
Usable sensitivity (IHF)	16.8 dBf
Antenna terminals	75 ohms (unbalanced)

MW tuner section

Tuning range	531 kHz to 1602 kHz (9 kHz step) 530 kHz to 1710 kHz (10 kHz step)
Usable sensitivity	350 μ V/m
Antenna	Loop antenna

LW tuner section

Tuning range	144 kHz to 290 kHz
Usable sensitivity	1400 μ V/m
Antenna	Loop antenna

Amplifier section

Power output	Rated: 6.4 W + 6.4 W (6 ohms, T.H.D. 1%, 1 kHz/DIN 45500) Reference: 8 W + 8 W (6 ohms, T.H.D. 10%, 1 kHz/DIN 45324) DIN MUSIC POWER: 15 W + 15 W
Total harmonic distortion	0.1% (3 W, 1 kHz, 6 ohms, DIN AUDIO)
Inputs	VIDEO/AUX: 500 mV
Outputs	SPEAKERS: accept speakers of 6 ohms or more PHONES (stereo jack): accepts headphones of 32 ohms or more

Cassette deck section

Track format	4 tracks, 2 channels stereo
Frequency response	50 Hz – 8000 Hz
Recording system	AC bias
Heads	Deck 1: Recording/playback head × 1, erase head × 1 Deck 2: Playback head × 1

Compact disc player section

Laser	Semiconductor laser ($\lambda = 780$ nm)
D/A converter	1 bit dual
Signal-to-noise ratio	85 dB (1 kHz, 0 dB)
Harmonic distortion	0.05% (1 kHz, 0 dB)

General

Power requirements	230 V AC, 50 Hz
Power consumption	42 W
Power consumption in standby mode	14 W with power-economizing mode off 0.9 W with power-economizing mode on
Dimensions (W × H × D)	260 × 324 × 346 mm
Weight	4.7 kg

Speaker system SX-NSZ5/SX-NSZ7

Speaker system	2 way, bass reflex (magnetic shielded type)
Speaker units	Woofer: 120 mm cone type Tweeter: 20 mm ceramic type
Impedance	6 ohms
Sensitivity	87 dB/W/m
Dimensions (W × H × D)	220 × 324 × 204 mm
Weight	2.0 kg

• Design and specifications are subject to change without notice.

ACCESSORIES LIST

REF. NO	PART NO.	KANRI NO.	DESCRIPTION
1	8A-NFB-916-110		IB,EZ (9L) M -SZ7 (RDS) <NDR2>
1	8A-NFB-918-010		IB,EZ (9L) S<NDR3>
2	87-A90-118-010		ANT,WIRE FM (Z)
3	87-A90-030-010		ANT,LOOP AM-NC C<NDR3>
3	87-006-225-010		ANT,LOOP ANT NC2<NDR2>
4	8Z-NF9-701-210		RC UNIT,ZAS02<NDR2>
4	8Z-NF9-702-010		RC UNIT,ZAS02<NDR3>

PROTECTION OF EYES FROM LASER BEAM DURING SERVICING

This set employs laser. Therefore, be sure to follow carefully the instructions below when servicing.

WARNING!

WHEN SERVICING, DO NOT APPROACH THE LASER EXIT WITH THE EYE TOO CLOSELY. IN CASE IT IS NECESSARY TO CONFIRM LASER BEAM EMISSION. BE SURE TO OBSERVE FROM A DISTANCE OF MORE THAN 30cm FROM THE SURFACE OF THE OBJECTIVE LENS ON THE OPTICAL

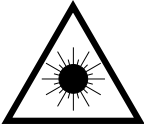

- Caution: Invisible laser radiation when open and interlocks defeated avoid exposure to beam.
- Advarsel: Usynlig laserstråling ved åbning, når sikkerhedsafbrydere er ude af funktion. Undgå udsættelse for stråling.

VAROITUS!

Laiteen Käyttäminen muulla kuin tässä käyttöohjeessa mainitulla tavalla saattaa altistaa käyt-täjän turvallisuusluokan 1 ylittävälle näkymättömälle lasersäteilylle.

WARNING!

Om apparaten används på annat sätt än vad som specificeras i denna bruksanvisning, kan användaren utsättas för osynlig laserstrålning, som överskrider gränsen för laserklass 1.

CAUTION

Use of controls or adjustments or performance of procedures other than those specified herein may result in hazardous radiation exposure.

ATTENTION

L'utilisation de commandes, réglages ou procédures autres que ceux spécifiés peut entraîner une dangereuse exposition aux radiations.

ADVARSEL!

Usynlig laserstråling ved åbning, når sikkerhedsafbrydere er ude af funktion. Undgå udsættelse for stråling.

This Compact Disc player is classified as a CLASS 1 LASER product. The CLASS 1 LASER PRODUCT label is located on the rear exterior.

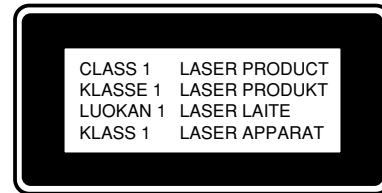

Precaution to replace Optical block (KSS-213F)

Body or clothes electrostatic potential could ruin laser diode in the optical block. Be sure ground body and workbench, and use care the clothes do not touch the diode.

- 1) After the connection, remove solder shown in the right figure.

PICK-UP Assy PWB

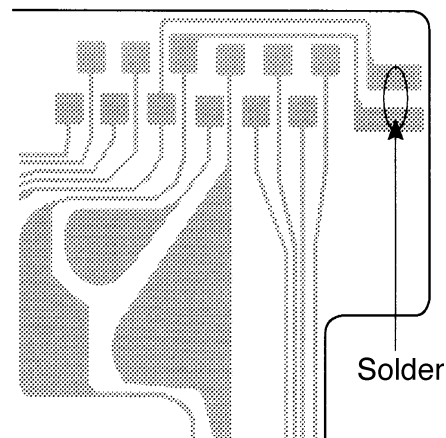

NOTE ON BEFORE STARTING REPAIR -1/2

1. Forced discharge of electrolytic capacitor of power supply block

When repair is going to be attempted in the set that uses relay circuit in the power supply block, electric potential is kept charged across the electrolytic capacitors (C101, 102) even though AC power cord is removed. If repair is attempted in this condition, secondary defect can occur. In order to prevent the secondary trouble, perform the following measures before starting repair work.

Discharge procedure

- ① Remove the AC power cord.
- ② Connect a discharging resistor at an end of lead wire that has clips at both ends. Connect the other end of the lead wire to metal chassis.
- ③ Contact the other end of the discharging resistor to the positive (+) side (+VH) of C101. (For two seconds)
- ④ Contact the same end of the discharging resistor as step ③ to the negative (-) side (-VH) of C102 in the same way. (For two seconds)
- ⑤ Check that voltage across C101 and C102 has decreased to 1 V or less using a multimeter or an oscilloscope.

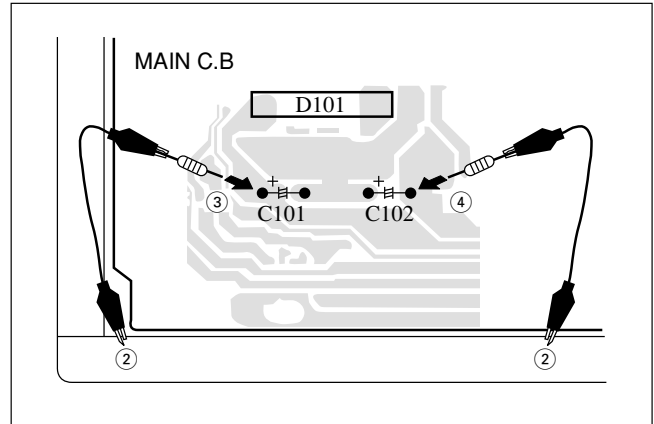

Fig-1

Select a discharging resistor referring to the following table.

Charging voltage (V) (C101, 102)	Discharging resistor ()	Rated power (W)	Parts number
25-48	100	3	87-A00-247-090
49-140	220	5	87-A00-232-090

Note: The reference numbers (C101, C102) of the electrolytic capacitors can change depending on the models. Be sure to check the reference numbers of the charging capacitors on schematic diagram before starting the discharging work.

2. Check items before exchanging the MICROCOMPUTER

Be sure to check the following items before exchanging the MICROCOMPUTER. Exchange the MICROCOMPUTER after confirming that the MICROCOMPUTER is surely defective.

2-1. Regarding the HOLD terminal of the MICROCOMPUTER

When the HOLD terminal (INPUT) of the MICROCOMPUTER is “H”, the MICROCOMPUTER is judged to be operating correctly. When this terminal is “L”, the main power cannot be turned on. Therefore, be sure to check the terminal voltage of the HOLD terminal before exchange.

When the MICROCOMPUTER is not defective, the HOLD terminal can also go “L” when the POWER AMPLIFIER has any abnormalities that triggers the abnormality detection circuit on the MAIN C. B. that sets the HOLD terminal to “L”.

• Good or no good judgement of the MICROCOMPUTER

- ① Turn on the AC main power.
- ② Confirm that the main power is turned on and the HOLD terminal of the MICROCOMPUTER keeps the “H” level or not.
- ③ When the HOLD terminal is “L” level, the abnormality detection circuit is judged to be working correctly and the MICROCOMPUTER is judged to be good.

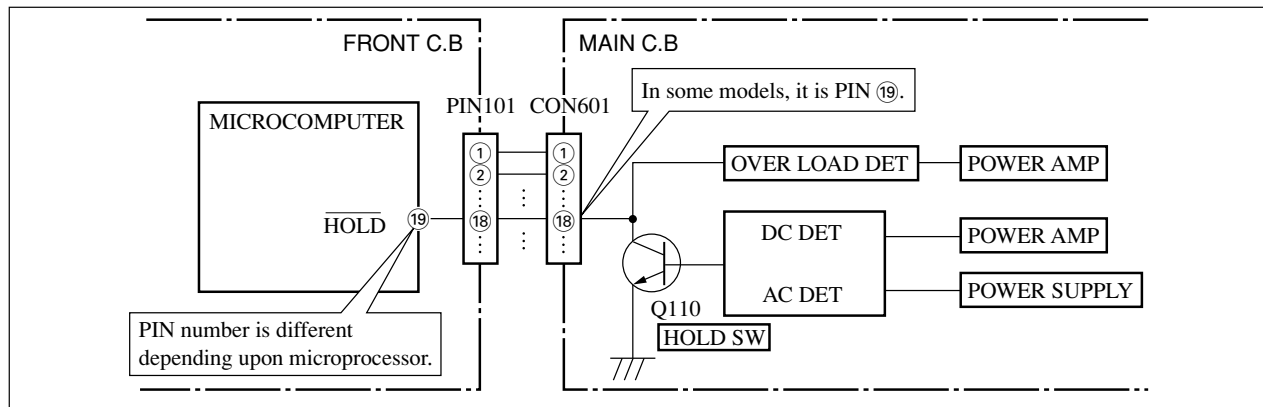

Fig-2-1

NOTE ON BEFORE STARTING REPAIR -2/2

In such a case, check also if the POWER AMPLIFIER circuit or power supply circuit has any abnormalities or not.

2-2. Regarding reset

There are cases that the machine does not work correctly because the MICROCOMPUTER is not reset even though the AC power cord is re-inserted, or the software reset (pressing the STOP key + POWER key) is performed.

When the above described phenomenon occurs, it can lead to wrong judgement as if the MICROCOMPUTER is defective and to exchange the MICROCOMPUTER. In such a case, perform the forced-reset by the following procedure and check good or no good of the MICROCOMPUTER.

- ① Remove the AC power cord.

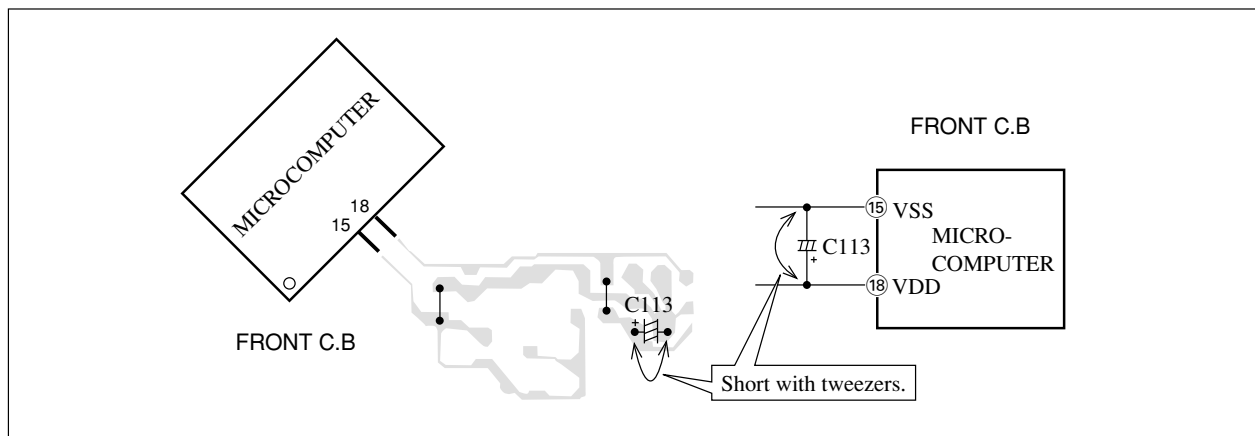

Fig-2-2

- ② Short both ends of the electrolytic capacitor C113 that is connected to VDD of the MICROCOMPUTER with tweezers.
- ③ Connect the AC power cord again. If the MICROCOMPUTER returns to the normal operation, the MICROCOMPUTER is good.

Note: The reference number or MICROCOMPUTER pin number of transistor (Q110) and electrolytic capacitor (C113) can change depending on the models. Be sure to check the reference numbers on schematic diagram before starting the discharging work.

2-3. Confirmation of soldering state of MICROCOMPUTER

Check the soldering state of the MICROCOMPUTER in addition to the above described procedures. Be sure to exchange the MICROCOMPUTER after surely confirming that the trouble is not caused by poor soldering but the MICROCOMPUTER itself.

ELECTRICAL MAIN PARTS LIST -1/3

REF. NO	PART NO.	KANRI NO.	DESCRIPTION	REF. NO	PART NO.	KANRI NO.	DESCRIPTION
IC				C0106	87-010-186-080		C-CAP,S 4700P-50 K B C2012
	8A-NFA-615-010		C-IC,M38B57MCH-E236FP<NDR3>	C0107	87-010-403-080		CAP,E 3.3-50 M 11L SME
	8A-NFA-616-010		C-IC,M38B59MFH-E251FP<NDR2>	C0108	87-010-403-080		CAP,E 3.3-50 M 11L SME
	87-A21-482-010		IC,RPM6938-H4	C0109	87-010-322-080		C-CAP,S 100P-50 J CH GRM
	87-A21-419-040		C-IC,NJM1455MD-TE2	C0110	87-010-322-080		C-CAP,S 100P-50 J CH GRM
	87-A21-443-040		C-IC,M62495AFP	C0111	87-010-260-080		CAP,E 47-25 M 11L SME
	87-A21-695-010		IC,LA1845L	C0112	87-010-260-080		CAP,E 47-25 M 11L SME
	87-A20-440-040		C-IC,BUI920FS<NDR2>	C0113	87-010-322-080		C-CAP,S 100P-50 J CH GRM
	87-A21-928-010		IC,LC72131D-N	C0114	87-010-322-080		C-CAP,S 100P-50 J CH GRM
				C0119	87-010-197-080		C-CAP,S 0.01-25 K B C2012
TRANSISTOR				C0120	87-010-197-080		C-CAP,S 0.01-25 K B C2012
	87-026-609-080		TR,KTA1266GR	C0123	87-010-197-080		C-CAP,S 0.01-25 K B C2012
	89-213-702-010		TR,2SB1370E	C0124	87-010-197-080		C-CAP,S 0.01-25 K B C2012
	87-026-610-080		TR,KTC3198GR	C0125	87-010-196-080		C-CAP,S 0.1-25 Z F C2012
	87-A30-076-080		C-TR,2SC3052F	C0126	87-010-196-080		C-CAP,S 0.1-25 Z F C2012
	87-A30-075-080		C-TR,2SA1235F	C0127	87-010-196-080		C-CAP,S 0.1-25 Z F C2012
	87-A30-090-080		FET,2SK2541	C0128	87-010-196-080		C-CAP,S 0.1-25 Z F C2012
	87-A30-484-040		C-TR,KRA102S	C0133	87-010-186-080		C-CAP,S 4700P-50 K B C2012
	87-A30-468-040		C-TR,KRC102S-RTK	C0140	87-010-182-080		C-CAP,S 2200P-50 K B C2012
	89-420-613-010		TR,2SD2061F	C0301	87-010-179-080		C-CAP,S 1200P-50 K B GRM
	89-213-703-010		TR,2SB1370F	C0302	87-010-179-080		C-CAP,S 1200P-50 K B GRM
	87-A30-091-080		FET,2SJ460	C0303	87-010-178-080		C-CAP,S 1000P-50 K B C2012
	87-A30-062-040		C-TR,KRC104S	C0304	87-010-178-080		C-CAP,S 1000P-50 K B C2012
	87-A30-495-080		TR,2SA1981Y	C0305	87-010-198-080		C-CAP,S 0.022-25 K B C2012
	87-A30-492-080		TR,2SC5343G	C0307	87-010-263-080		CAP,E 100-10 M 11L SME
	87-A30-234-080		TR,CSC4115BC	C0308	87-010-263-080		CAP,E 100-10 M 11L SME
	89-327-143-080		C-TR,2SC27140	C0309	87-010-311-080		C-CAP,S 12P-50 J CH GRM
	87-A30-489-040		C-TR,KRA107S	C0310	87-010-314-080		C-CAP,S 22P-50 J CH GRM
	87-A30-086-040		C-TR,CSD1306E	C0311	87-010-598-080		C-CAP,S 0.068-16 K R GRM
	89-503-602-080		C-FET,2SK360E	C0312	87-010-598-080		C-CAP,S 0.068-16 K R GRM
DIODE				C0313	87-010-188-080		C-CAP,S 6800P-50 K B C2012
	87-A40-535-080		DIODE,1N5393-GOODARK	C0314	87-010-188-080		C-CAP,S 6800P-50 K B C2012
	87-A40-553-080		DIODE,1N4003 LES	C0315	87-010-263-080		CAP,E 100-10 M 11L SME
	87-A40-774-080		ZENER,UZ24BSD	C0317	87-010-546-080		CAP,E 0.33-50 M 11L SME
	87-020-465-080		DIODE,1SS133	C0318	87-010-546-080		CAP,E 0.33-50 M 11L SME
	87-A40-764-080		ZENER,UZ10BSC	C0320	87-010-196-080		C-CAP,S 0.1-25 Z F C2012
	87-A40-752-080		ZENER,UZ6.2BSC	C0321	87-010-196-080		C-CAP,S 0.1-25 Z F C2012
	87-A40-270-080		C-DIODE,MC2838	C0324	87-010-196-080		C-CAP,S 0.1-25 Z F C2012
	87-A40-269-080		C-DIODE,MC2836	C0325	87-010-196-080		C-CAP,S 0.1-25 Z F C2012
	87-A40-739-080		ZENER,UZ2.7BSA	C0326	87-010-198-080		C-CAP,S 0.022-25 K B C2012
	87-017-149-080		ZENER,HZS6A2L	C0327	87-010-196-080		C-CAP,S 0.1-25 Z F C2012
MAIN C.B				C0350	87-010-196-080		C-CAP,S 0.1-25 Z F C2012
C0009	87-010-196-080		C-CAP,S 0.1-25 Z F C2012	C0360	87-010-401-080		CAP,E 1-50 M 11L SME
C0010	87-010-196-080		C-CAP,S 0.1-25 Z F C2012	C0363	87-010-197-080		C-CAP,S 0.01-25 K B C2012
C0011	87-010-196-080		C-CAP,S 0.1-25 Z F C2012	C0399	87-012-140-080		C-CAP,S 470P-50 J CH
C0012	87-010-196-080		C-CAP,S 0.1-25 Z F C2012	C0401	87-010-544-080		CAP,E 0.1-50 M 11L SME
C0021	87-016-495-090		CAP,E 3300-25 M SMG	C0402	87-010-544-080		CAP,E 0.1-50 M 11L SME
C0022	87-A10-831-080		CAP,E 1000-25 M SMG	C0403	87-010-321-080		C-CAP,S 82P-50 J CH
C0025	87-010-383-080		CAP,E 33-25 M 11L SME	C0404	87-010-321-080		C-CAP,S 82P-50 J CH
C0026	87-010-383-080		CAP,E 33-25 M 11L SME	C0405	87-010-197-080		C-CAP,S 0.01-25 K B C2012
C0030	87-010-384-080		CAP,E 100-25 M 11L SME	C0406	87-010-197-080		C-CAP,S 0.01-25 K B C2012
C0031	87-010-263-080		CAP,E 100-10 M 11L SME	C0407	87-010-197-080		C-CAP,S 0.01-25 K B C2012
C0032	87-010-197-080		C-CAP,S 0.01-25 K B C2012	C0408	87-010-197-080		C-CAP,S 0.01-25 K B C2012
C0034	87-010-247-080		CAP,E 100-50 M SME	C0409	87-010-182-080		C-CAP,S 2200P-50 K B C2012
C0035	87-010-406-080		CAP,E 22-50 M 11L SME	C0410	87-010-182-080		C-CAP,S 2200P-50 K B C2012
C0036	87-010-381-080		CAP,E 330-16 M SME	C0411	87-010-405-080		CAP,E 10-50 M 11L SME
C0038	87-010-190-080		C-CAP,S 0.01-50 Z F C2012	C0412	87-010-405-080		CAP,E 10-50 M 11L SME
C0050	87-010-384-080		CAP,E 100-25 M 11L SME	C0452	87-010-382-080		CAP,E 22-25 M 11L SME
C0060	87-010-403-080		CAP,E 3.3-50 M 11L SME	C0453	87-010-183-080		C-CAP,S 2700P-50 K B GRM
C0061	87-010-260-080		CAP,E 47-25 M 11L SME	C0454	87-010-183-080		C-CAP,S 2700P-50 K B GRM
C0101	87-010-185-080		C-CAP,S 3900P-50 K B	C0455	87-010-183-080		C-CAP,S 2700P-50 K B GRM
C0102	87-010-185-080		C-CAP,S 3900P-50 K B	C0456	87-010-197-080		C-CAP,S 0.01-25 K B C2012
C0103	87-010-545-080		CAP,E 0.22-50 M 11L SME	C0457	87-A12-361-080		CAP,M 5600P-100 J CP
C0104	87-010-545-080		CAP,E 0.22-50 M 11L SME	C0458	87-010-178-080		C-CAP,S 1000P-50 K B C2012
C0105	87-010-186-080		C-CAP,S 4700P-50 K B C2012	C0459	87-010-175-080		C-CAP,S 560P-50 J SL
				C0460	87-010-196-080		C-CAP,S 0.1-25 Z F C2012
				C0461	87-012-158-080		C-CAP,S 390P-50 J CH GRM
				C0462	87-012-158-080		C-CAP,S 390P-50 J CH GRM
				C0470	87-018-127-080		CAP,TC U 470P-50 K B UP050
				C0605	87-010-179-080		C-CAP,S 1200P-50 K B GRM

ELECTRICAL MAIN PARTS LIST -2/3

REF. NO	PART NO.	KANRI NO.	DESCRIPTION	REF. NO	PART NO.	KANRI NO.	DESCRIPTION
C0606	87-010-179-080		C-CAP,S 1200P-50 K B GRM	C0876	87-010-405-080		CAP,E 10-50 M 11L SME<NDR2>
C0609	87-010-213-080		C-CAP,S 0.015-25 K B GRM	C0877	87-010-197-080		C-CAP,S 0.01-25 K B C2012<NDR2>
C0610	87-010-213-080		C-CAP,S 0.015-25 K B GRM	C0878	87-010-316-080		C-CAP,S 33P-50 J CH GRM<NDR2>
C0611	87-010-545-080		CAP,E 0.22-50 M 11L SME	C0879	87-010-314-080		C-CAP,S 22P-50 J CH GRM<NDR2>
C0612	87-010-545-080		CAP,E 0.22-50 M 11L SME	C0940	87-010-197-080		C-CAP,S 0.01-25 K B C2012
C0613	87-010-545-080		CAP,E 0.22-50 M 11L SME	C0942	87-010-149-080		C-CAP,S 5P-50 C CH GRM
C0614	87-010-545-080		CAP,E 0.22-50 M 11L SME	C0947	87-010-197-080		C-CAP,S 0.01-25 K B C2012
C0615	87-010-154-080		C-CAP,S 10P-50 D CH GRM	C0948	87-012-140-080		C-CAP,S 470P-50 J CH
C0616	87-010-248-080		CAP,E 220-10 M 11L SME	C0952	87-010-197-080		C-CAP,S 0.01-25 K B C2012
C0617	87-010-248-080		CAP,E 220-10 M 11L SME	C0957	87-010-311-080		C-CAP,S 12P-50 J CH GRM
C0618	87-010-405-080		CAP,E 10-50 M 11L SME	C0958	87-010-197-080		C-CAP,S 0.01-25 K B C2012
C0630	87-016-669-080		C-CAP,S 0.1-25 K B	C0959	87-010-196-080		C-CAP,S 0.1-25 Z F C2012
C0669	87-010-322-080		C-CAP,S 100P-50 J CH GRM	C0960	87-010-196-080		C-CAP,S 0.1-25 Z F C2012
C0670	87-010-322-080		C-CAP,S 100P-50 J CH GRM	C0962	87-010-401-080		CAP,E 1-50 M 11L SME
C0677	87-010-197-080		C-CAP,S 0.01-25 K B C2012	C0963	87-015-785-080		C-CAP, 0.1-25 Z F C3216
C0771	87-010-263-080		CAP,E 100-10 M 11L SME	C0971	87-010-381-080		CAP,E 330-16 M SME
C0772	87-010-197-080		C-CAP,S 0.01-25 K B C2012	C0972	87-010-404-080		CAP,E 4.7-50 M 11L SME
C0779	87-010-971-080		C-CAP,S 4700P-50 J B	C0973	87-010-197-080		C-CAP,S 0.01-25 K B C2012
C0780	87-010-971-080		C-CAP,S 4700P-50 J B	C0974	87-010-197-080		C-CAP,S 0.01-25 K B C2012
C0782	87-010-197-080		C-CAP,S 0.01-25 K B C2012	C0979	87-010-322-080		C-CAP,S 100P-50 J CH GRM
C0783	87-010-197-080		C-CAP,S 0.01-25 K B C2012	C0981	87-010-260-080		CAP,E 47-25 M 11L SME
C0784	87-010-197-080		C-CAP,S 0.01-25 K B C2012	C0982	87-010-196-080		C-CAP,S 0.1-25 Z F C2012
C0785	87-010-197-080		C-CAP,S 0.01-25 K B C2012	C0983	87-010-197-080		C-CAP,S 0.01-25 K B C2012
C0786	87-010-197-080		C-CAP,S 0.01-25 K B C2012	C0984	87-010-197-080		C-CAP,S 0.01-25 K B C2012
C0788	87-010-149-080		C-CAP,S 5P-50 C CH GRM	C0985	87-010-322-080		C-CAP,S 100P-50 J CH GRM
C0789	87-A10-801-080		C-CAP,S 0.022-16 J B CM	C0987	87-010-197-080		C-CAP,S 0.01-25 K B C2012
C0790	87-A10-801-080		C-CAP,S 0.022-16 J B CM	C0989	87-010-197-080		C-CAP,S 0.01-25 K B C2012
C0791	87-010-196-080		C-CAP,S 0.1-25 Z F C2012	C0991	87-010-312-080		C-CAP,S 15P-50 J CH GRM
C0792	87-010-197-080		C-CAP,S 0.01-25 K B C2012	C0992	87-010-312-080		C-CAP,S 15P-50 J CH GRM
C0793	87-010-404-080		CAP,E 4.7-50 M 11L SME	C0993	87-010-178-080		C-CAP,S 1000P-50 K B C2012
C0794	87-010-322-080		C-CAP,S 100P-50 J CH GRM	C0995	87-010-178-080		C-CAP,S 1000P-50 K B C2012
C0795	87-010-197-080		C-CAP,S 0.01-25 K B C2012	C0997	87-010-196-080		C-CAP,S 0.1-25 Z F C2012
C0796	87-010-197-080		C-CAP,S 0.01-25 K B C2012	C0998	87-010-260-080		CAP,E 47-25 M 11L SME
C0797	87-010-405-080		CAP,E 10-50 M 11L SME	C0999	87-A11-155-080		CAP,TC U 0.01-16 Z F
C0798	87-010-197-080		C-CAP,S 0.01-25 K B C2012	CF0831	87-008-423-010		FLTR,CF SFE10.7MS3G-A
C0799	87-010-407-080		CAP,E 33-50 M 11L SME	CF0832	82-785-747-010		CF,MS2 GHY,R
C0800	87-012-369-080		C-CAP,S 0.047-50 Z F	CN0301	87-A60-620-010		CONN,3P V 2MM JMT
C0801	87-010-403-080		CAP,E 3.3-50 M 11L SME	CN0351	87-A60-625-010		CONN,8P V 2MM JMT
C0802	87-012-369-080		C-CAP,S 0.047-50 Z F	CN0601	87-099-719-010		CONN,30P H BLK TYK-B(X)
C0803	87-010-198-080		C-CAP,S 0.022-25 K B C2012	CN0602	87-099-194-010		CONN,6P V BLK 6216
C0804	87-010-263-080		CAP,E 100-10 M 11L SME	CON0301	8A-NFA-633-010		CONN ASSY,3P (PH)
C0807	87-010-400-080		CAP,E 0.47-50 M 11L SME	CON0351	8A-NFA-634-010		CONN ASSY,8P RPB
C0808	87-010-401-080		CAP,E 1-50 M 11L SME	FB0301	87-008-372-080		FLTR,EMI BL01 RN1
C0809	87-010-401-080		CAP,E 1-50 M 11L SME	FB0602	87-008-372-080		FLTR,EMI BL01 RN1
C0810	87-010-196-080		C-CAP,S 0.1-25 Z F C2012	FFC0602	88-906-181-110		FF-CABLE, 6P 1.25
C0814	87-010-197-080		C-CAP,S 0.01-25 K B C2012	FFE0831	A8-6ZA-199-170		6ZA-1 FEENC<NDR3>
C0815	87-010-403-080		CAP,E 3.3-50 M 11L SME	FFE0831	A8-6ZA-19H-030		6ZA-1 FEMENM<NDR2>
C0816	87-010-403-080		CAP,E 3.3-50 M 11L SME	J0101	87-A60-602-010		JACK,DIA6.3 BLK ST W/SW TC
C0818	87-010-180-080		C-CAP,S 1500P-50 K B C2012	J0103	87-A60-238-010		TERMINAL,SP 4P (MSC)
C0821	87-010-405-080		CAP,E 10-50 M 11L SME	J0602	87-A60-881-010		JACK,PIN 2P MSP 242V05 PBSN
C0823	87-012-349-080		C-CAP,S 1000P-50 J CH GRM	J0832	87-A60-403-010		TERMINAL,ANT PAL 2P HSP-312V05
C0824	87-010-404-080		CAP,E 4.7-50 M 11L SME	L0101	87-A50-611-010		COIL,1UH K(CS)<NDR3>
C0825	87-010-596-080		C-CAP,S 0.047-16 K R C2012	L0101	87-A50-610-010		COIL,1UH K(MDEC)<NDR2>
C0831	87-010-406-080		CAP,E 22-50 M 11L SME	L0102	87-A50-611-010		COIL,1UH K(CS)<NDR3>
C0842	87-010-197-080		C-CAP,S 0.01-25 K B C2012	L0102	87-A50-610-010		COIL,1UH K(MDEC)<NDR2>
C0844	87-010-197-080		C-CAP,S 0.01-25 K B C2012	L0451	87-007-342-010		COIL,OSC 85KHZ BIAS
C0850	87-010-260-080		CAP,E 47-25 M 11L SME	L0801	87-A50-608-010		COIL,FM DET-N(TOK)
C0851	87-010-197-080		C-CAP,S 0.01-25 K B C2012	L0802	87-A91-551-010		FLTR,PCFJZH-450 L(TOK)
C0852	87-010-197-080		C-CAP,S 0.01-25 K B C2012	L0811	87-005-847-080		COIL,2.2UH K CECS
C0853	87-010-197-080		C-CAP,S 0.01-25 K B C2012	L0832	87-005-847-080		COIL,2.2UH K CECS
C0858	87-010-196-080		C-CAP,S 0.1-25 Z F C2012	L0861	87-005-847-080		COIL,2.2UH K CECS<NDR2>
C0859	87-010-196-080		C-CAP,S 0.1-25 Z F C2012	L0941	87-A50-020-010		COIL,ANT LW (COI) 252KHZ
C0860	87-010-197-080		C-CAP,S 0.01-25 K B C2012	L0942	87-A50-019-010		COIL,OSC LW (COI) 856KHZ
C0869	87-010-197-080		C-CAP,S 0.01-25 K B C2012<NDR2>	L0951	8A-NF8-668-010		COIL,AM PACK 2(TOK)
C0870	87-010-178-080		C-CAP,S 1000P-50 K B C2012<NDR2>	R0653	87-016-669-080		C-CAP,S 0.1-25 K B
C0871	87-012-156-080		C-CAP,S 220P-50 J CH GRM<NDR2>	R0654	87-016-669-080		C-CAP,S 0.1-25 K B
C0872	87-012-156-080		C-CAP,S 220P-50 J CH GRM<NDR2>	R0790	87-010-197-080		C-CAP,S 0.01-25 K B C2012
C0873	87-012-140-080		C-CAP,S 470P-50 J CH<NDR2>	R0991	87-010-322-080		C-CAP,S 100P-50 J CH GRM
C0874	87-010-405-080		CAP,E 10-50 M 11L SME<NDR2>	R0993	87-010-322-080		C-CAP,S 100P-50 J CH GRM
C0875	87-010-196-080		C-CAP,S 0.1-25 Z F C2012<NDR2>	R0995	87-010-322-080		C-CAP,S 100P-50 J CH GRM

ELECTRICAL MAIN PARTS LIST -3/3

REF. NO	PART NO.	KANRI NO.	DESCRIPTION	REF. NO	PART NO.	KANRI NO.	DESCRIPTION
TC0942	87-A91-774-080		TRIMMER, PLY 30P 6.8X5.4 CDYL	S0101	87-A91-555-010		SW, RTRY EC12E24504
WH0001	87-A90-460-010		HLDR, WIRE 2.5-7P	S0301	87-A90-164-080		SW, TACT SKQNB(N)
X0861	87-A70-091-010		VIB, XTAL 4.332MHZ CSA-309<NDR2>	S0302	87-A90-164-080		SW, TACT SKQNB(N)
X0991	87-A70-061-010		VIB, XTAL 4.500MHZ CSA-309	S0303	87-A90-164-080		SW, TACT SKQNB(N)
				S0304	87-A90-164-080		SW, TACT SKQNB(N)
FRONT C.B				S0305	87-A90-164-080		SW, TACT SKQNB(N)
C0101	87-010-196-080		C-CAP, S 0.1-25 Z F C2012	S0306	87-A90-164-080		SW, TACT SKQNB(N)
C0102	87-012-369-080		C-CAP, S 0.047-50 Z F	S0307	87-A90-164-080		SW, TACT SKQNB(N)
C0103	87-010-374-040		CAP, E 47-10 M 11L SME	S0308	87-A90-164-080		SW, TACT SKQNB(N)
C0104	87-A10-797-040		CAP, E 47-35 M 5L SRM	S0309	87-A90-164-080		SW, TACT SKQNB(N)
C0105	87-010-192-080		C-CAP, S 0.022-50 Z F C2012	S0310	87-A90-164-080		SW, TACT SKQNB(N) <NDR2>
C0107	87-010-196-080		C-CAP, S 0.1-25 Z F C2012	S0311	87-A90-164-080		SW, TACT SKQNB(N) <NDR2>
C0108	87-010-178-080		C-CAP, S 1000P-50 K B C2012	S0312	87-A90-164-080		SW, TACT SKQNB(N) <NDR2>
C0109	87-012-369-080		C-CAP, S 0.047-50 Z F	S0321	87-A90-164-080		SW, TACT SKQNB(N)
C0110	87-010-197-080		C-CAP, S 0.01-25 K B C2012	S0322	87-A90-164-080		SW, TACT SKQNB(N)
C0111	87-010-196-080		C-CAP, S 0.1-25 Z F C2012	S0323	87-A90-164-080		SW, TACT SKQNB(N)
C0113	87-010-178-080		C-CAP, S 1000P-50 K B C2012	S0324	87-A90-164-080		SW, TACT SKQNB(N)
C0114	87-010-154-080		C-CAP, S 10P-50 D CH GRM	S0325	87-A90-164-080		SW, TACT SKQNB(N)
C0115	87-010-175-080		C-CAP, S 560P-50 J SL	S0326	87-A90-164-080		SW, TACT SKQNB(N)
C0116	87-010-400-040		CAP, E 0.47-50 M 11L SME	S0327	87-A90-164-080		SW, TACT SKQNB(N)
C0117	87-016-460-080		C-CAP, S 0.22-16 K B	S0328	87-A90-164-080		SW, TACT SKQNB(N)
C0118	87-A10-189-040		CAP, E 220-10 M 5L	S0329	87-A90-164-080		SW, TACT SKQNB(N)
C0119	87-A10-189-040		CAP, E 220-10 M 5L	S0330	87-A90-164-080		SW, TACT SKQNB(N)
C0120	87-012-156-080		C-CAP, S 220P-50 J CH GRM	S0331	87-A90-164-080		SW, TACT SKQNB(N)
C0123	87-010-196-080		C-CAP, S 0.1-25 Z F C2012	SFR0701	87-024-431-080		SFR, 3.3K H RH063MC
C0124	87-010-196-080		C-CAP, S 0.1-25 Z F C2012	PT C.B			
C0125	87-010-405-040		CAP, E 10-50 M 11L SME	C0183	87-010-387-080		CAP, E 470-25 M SME
C0126	87-010-196-080		C-CAP, S 0.1-25 Z F C2012	C0184	87-010-403-080		CAP, E 3.3-50 M 11L SME
C0129	87-010-374-040		CAP, E 47-10 M 11L SME	C0185	87-018-209-080		CAP, TC U 0.1-50 Z F UP050
C0210	87-012-156-080		C-CAP, S 220P-50 J CH GRM	△PT0001	8A-NFB-611-010		PT, ANF-B EZ LOW
C0212	87-010-404-040		CAP, E 4.7-50 M 11L SME	△PT0181	8A-NFB-662-010		PT, SUB ANF-8 (E)
C0213	87-010-404-040		CAP, E 4.7-50 M 11L SME	△RY0181	87-A90-976-010		RELAY, AC12V SDT-S-112LMR
C0701	87-010-384-040		CAP, E 100-25 M 11L SME	△T0181	87-A60-317-010		TERMINAL, 1P MSC
C0702	87-010-178-080		C-CAP, S 1000P-50 K B C2012	△T0182	87-A60-317-010		TERMINAL, 1P MSC
CN0101	87-099-720-010		CONN, 30P BLK TYK-B(P)	W0181	8A-NFA-628-010		F-CABLE, 7P 2.5 260MM
CN0701	87-A60-673-010		CONN, 9P H 2MM JMT	WH0181	87-A90-460-010		HLDR, WIRE 2.5-7P
CN0801	87-099-015-010		CONN, 13P V BLK 6216				
FFC0801	88-913-221-110		FF-CABLE, 13P 1.25 220MM				
FL0201	8A-NFA-604-010		FL, 10-BT-224GNK				
L0101	87-A50-655-010		COIL, CLK 4.19MHZ (TOKO) 7KLY				
LED0101	87-A40-317-080		LED, SLR-342VCT31 RED				

- Regarding connectors, they are not stocked as they are not the initial order items. The connectors are available after they are supplied from connector manufacturers upon the order is received.

チップ抵抗部品コード/CHIP RESISTOR PART CODE

チップ抵抗部品コードの成り立ち

Chip Resistor Part Coding



A
抵抗部品コード
Resistor Code

桁表示
Figure
抵抗値
Value of resistor

チップ抵抗 Chip resistor

容量 Wattage	種類 Type	許容誤差 Tolerance	記号 Symbol	寸法/Dimensions (mm)			抵抗コード : A Resistor Code : A	
				外形/Form	L	W		t
1/16W	1005	± 5%	CJ		1.0	0.5	0.35	104
1/16W	1608	± 5%	CJ		1.6	0.8	0.45	108
1/10W	2125	± 5%	CJ		2	1.25	0.45	118
1/8W	3216	± 5%	CJ		3.2	1.6	0.55	128

TRANSISTOR ILLUSTRATION



E C B

2SA1981
2SC5343
CSC4115
KTA1266
KTC3198

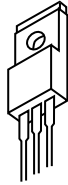

B C E

2SB1370
2SD2061

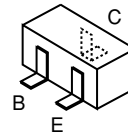

2SA1235
2SC2714
2SC3052
CSD1306
KRA102S
KRA107S
KRC102S
KRC104S



S D G

2SJ460
2SK2541

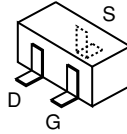

2SK302
2SK360
2SK882

SCHEMATIC DIAGRAM - 1/4 (MAIN AMP SECTION)

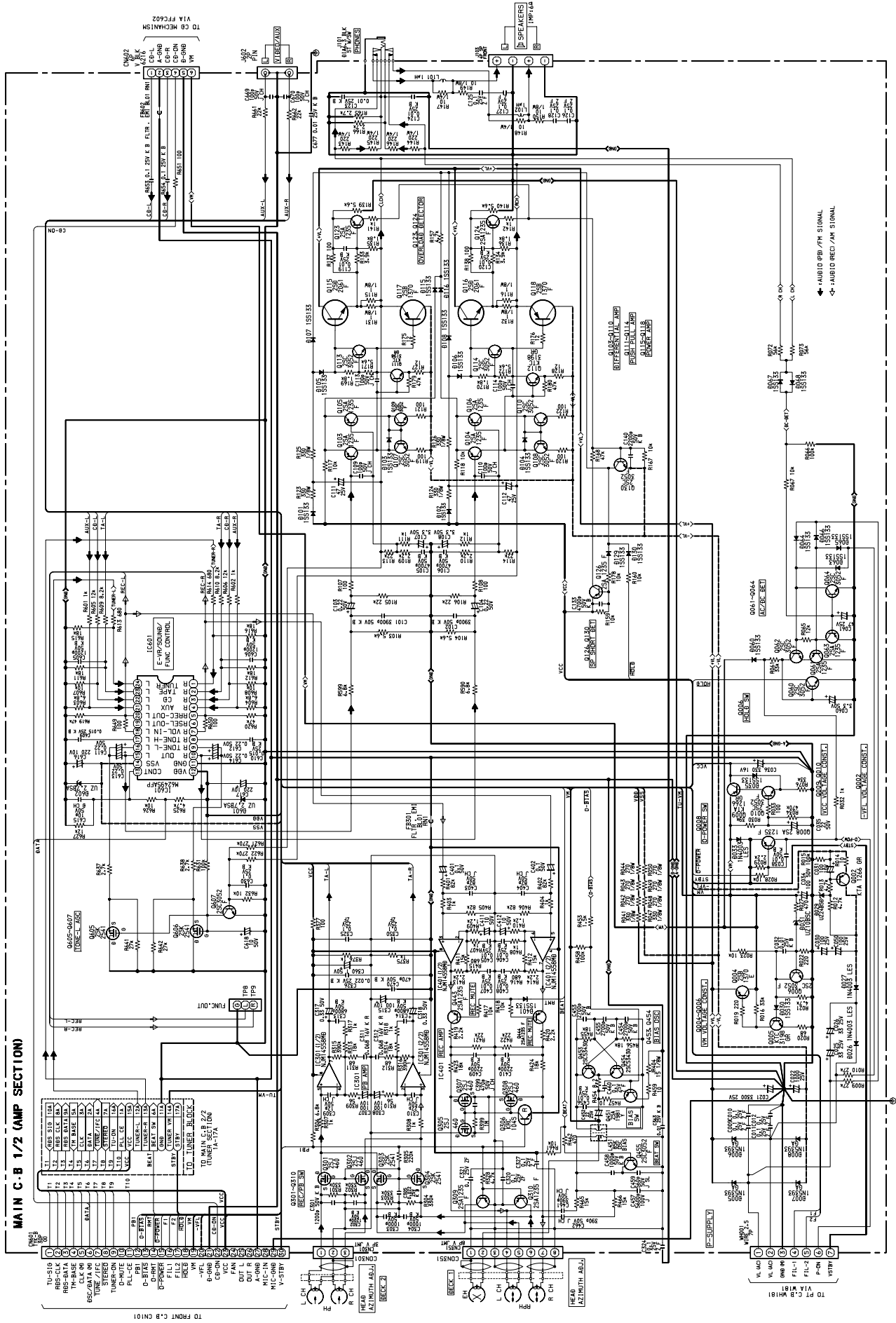

SCHEMATIC DIAGRAM - 2/4 (MAIN TUNER SECTION)

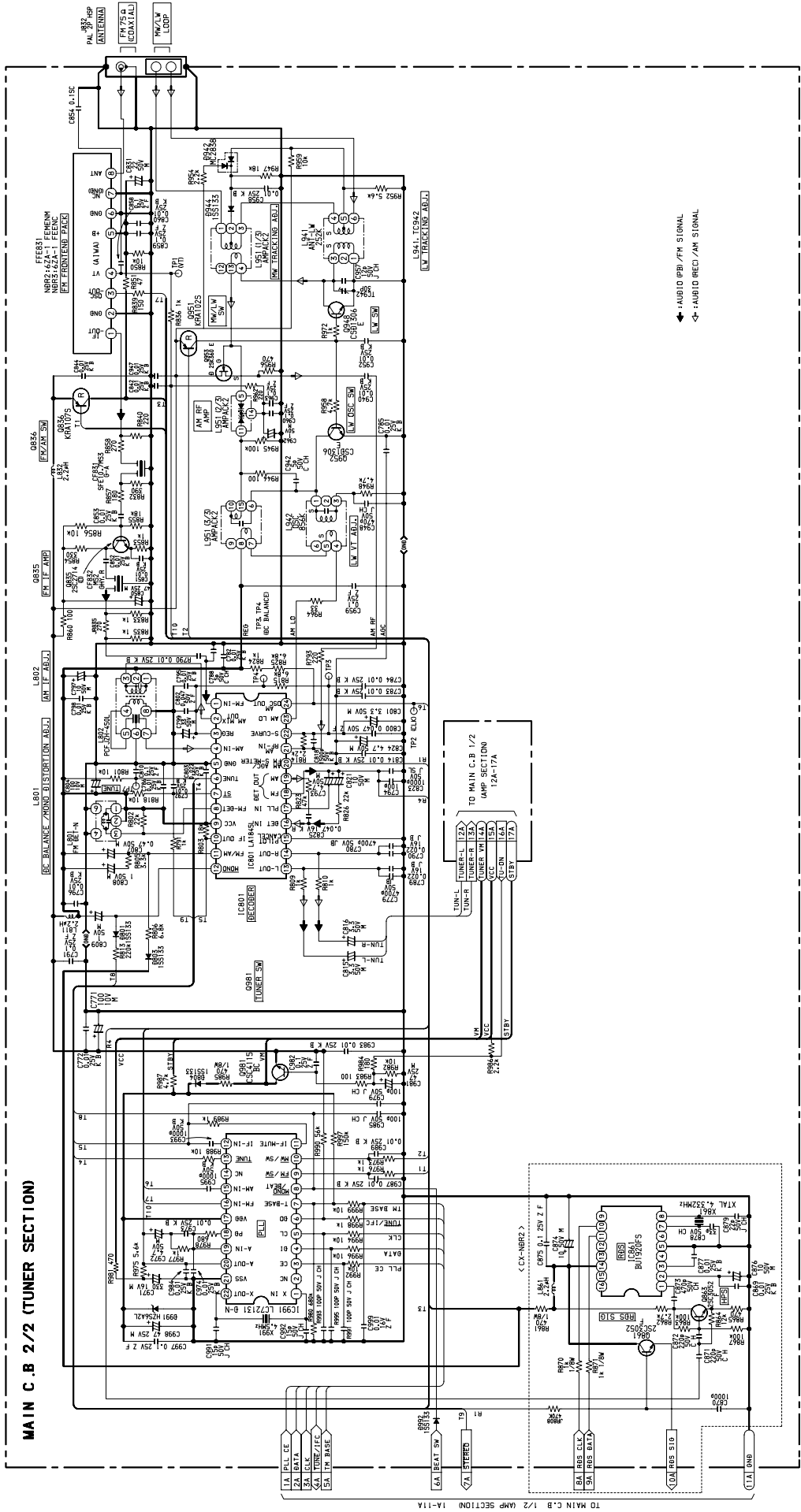

A B C D E F G H I J K L M N O P Q R S T U

1 2 3 4 5 6 7 8 9 10 11 12 13 14 15 16 17 18 19 20 21 22 23 24 25 26 27 28 29 30 31 32

TO CD MECHANISM
FFC602
1 6
CN602

TO DECK1
CON351
8
CN351

TO DECK2
CON301
8
CN301

MAIN C.B.

TPS, TP4, GC BALANCED

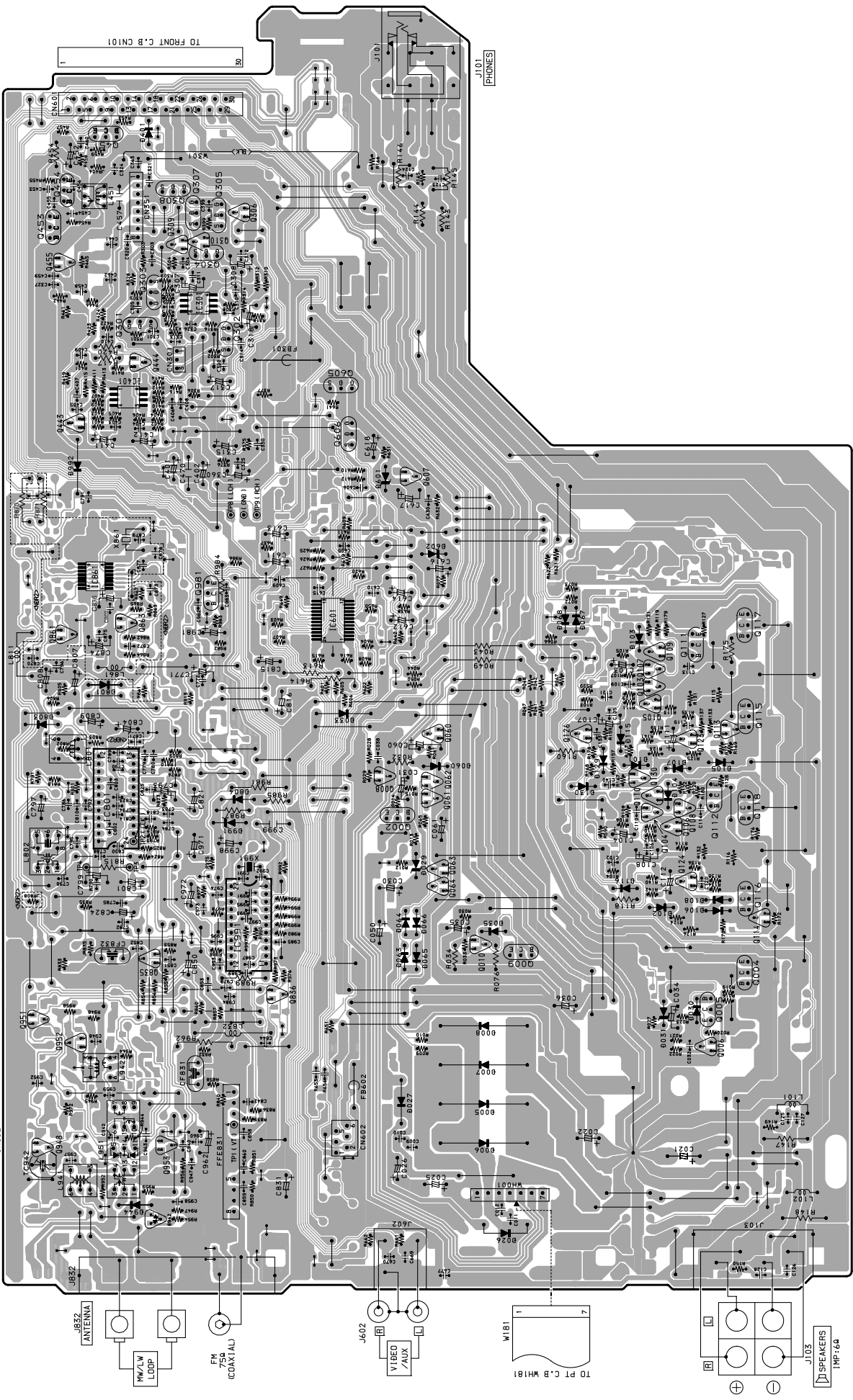

J852 ANTENNA
FM COAXIAL
WAVE LOOP

J602 VIDEO/AUX

W181 TO PT C.B. WH181

J103 SPEAKERS
IMP: 64

J101 PHONES

TO FRONT C.B. CN101

TO CB MECHANISM

FRONT C.B

FL201
DISPLAY

IC102
REMOTE
SENSOR

S501
POWER

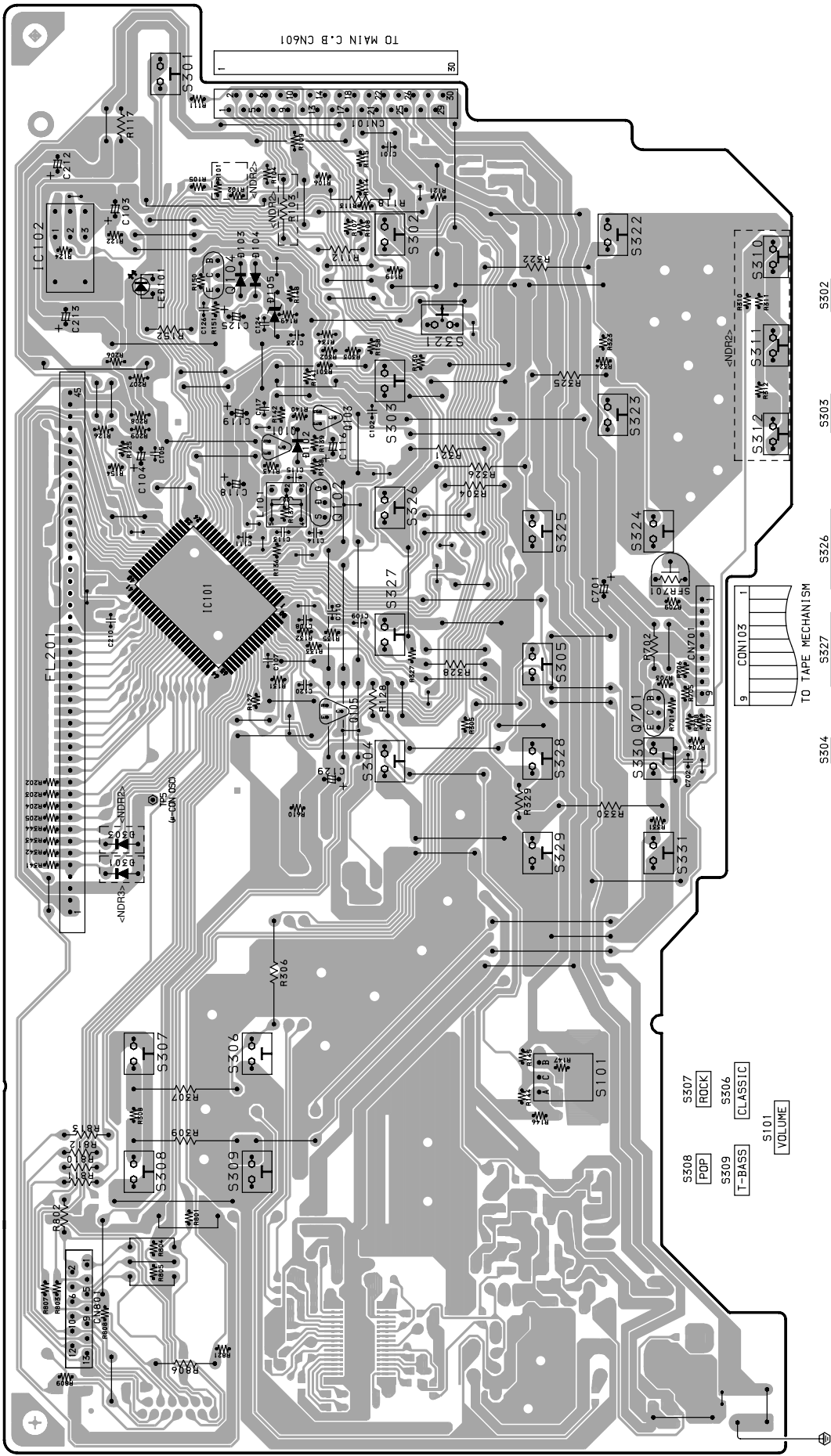

- S307 [ROCK]
- S308 [POP]
- S309 [T-BASS]
- S101 [VOLUME]
- S306 [CLASSIC]

- S329 [PRESET]
- S331 [UP]
- S330 [DOWN]
- S328 [CLEAR]
- S304 [CD]
- S327 [VIBED/AUX]
- S326 [TUNER/BAND]
- S325 [DISC CHANGE]
- S324 [OPEN/CLOSE]
- S305 [SET]

- S303 [TAPE]
- S321, S322, S323 [DISC DIRECT PLAY 1-3]
- S312 [AG]
- S311 [PTY]
- S310 [RT]
- S320 [ECCD]

TO TAPE MECHANISM

CONT103

TO MAIN C.B CN601

WIRING - 3/4 (DECK SECTION)

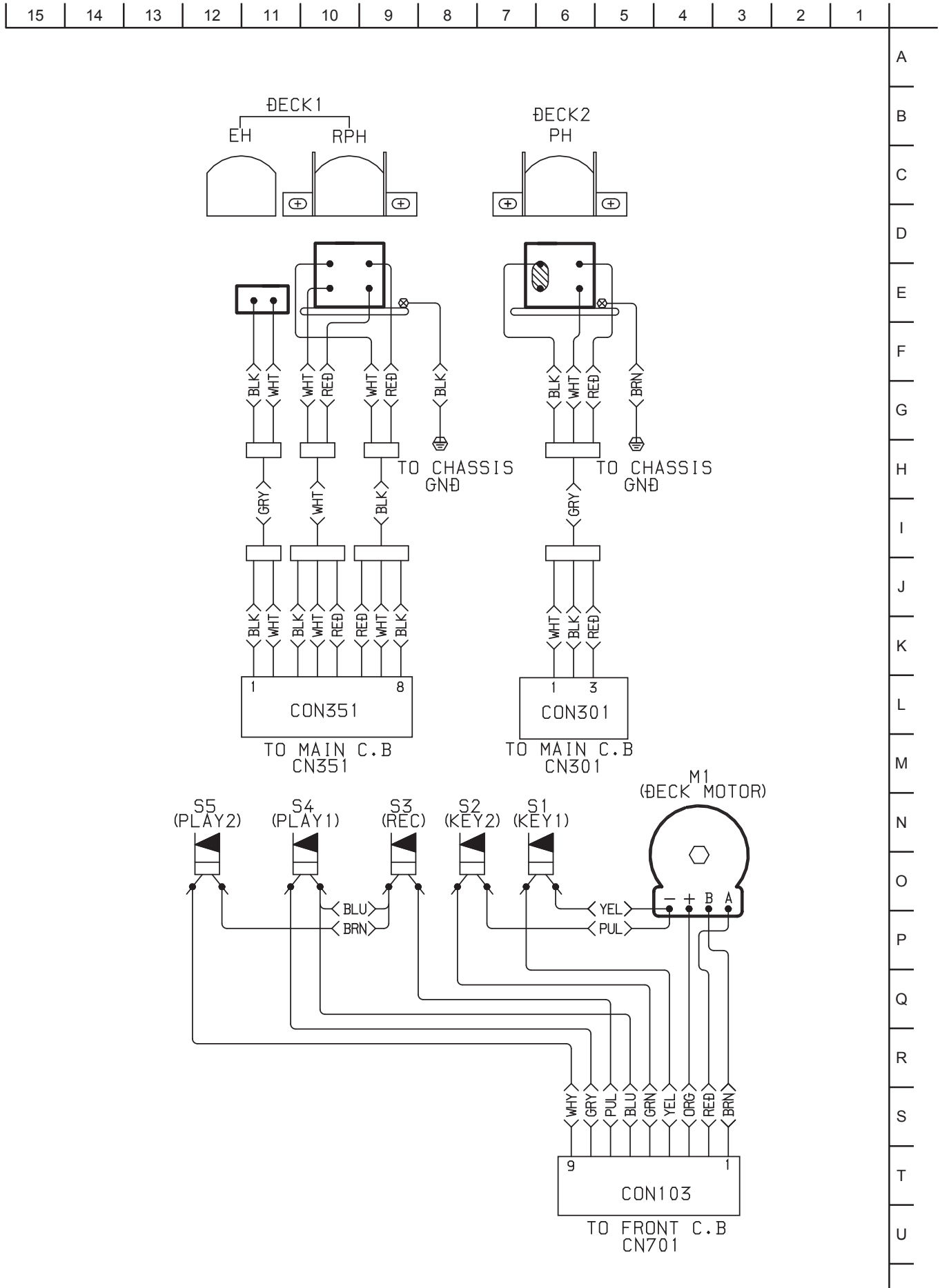

SCHEMATIC DIAGRAM -4/4 (PT SECTION)

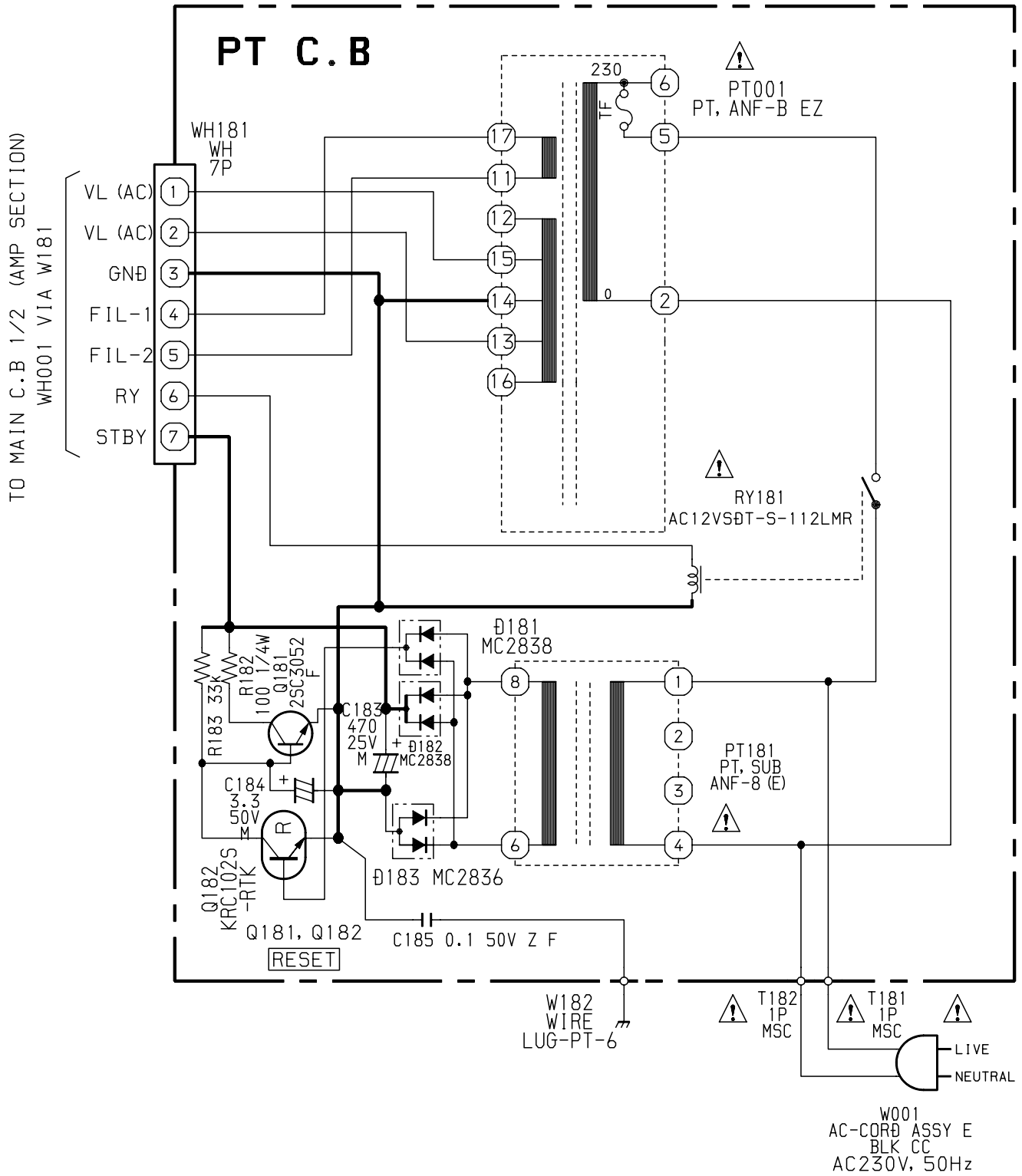

WIRING - 4/4 (PT C.B)

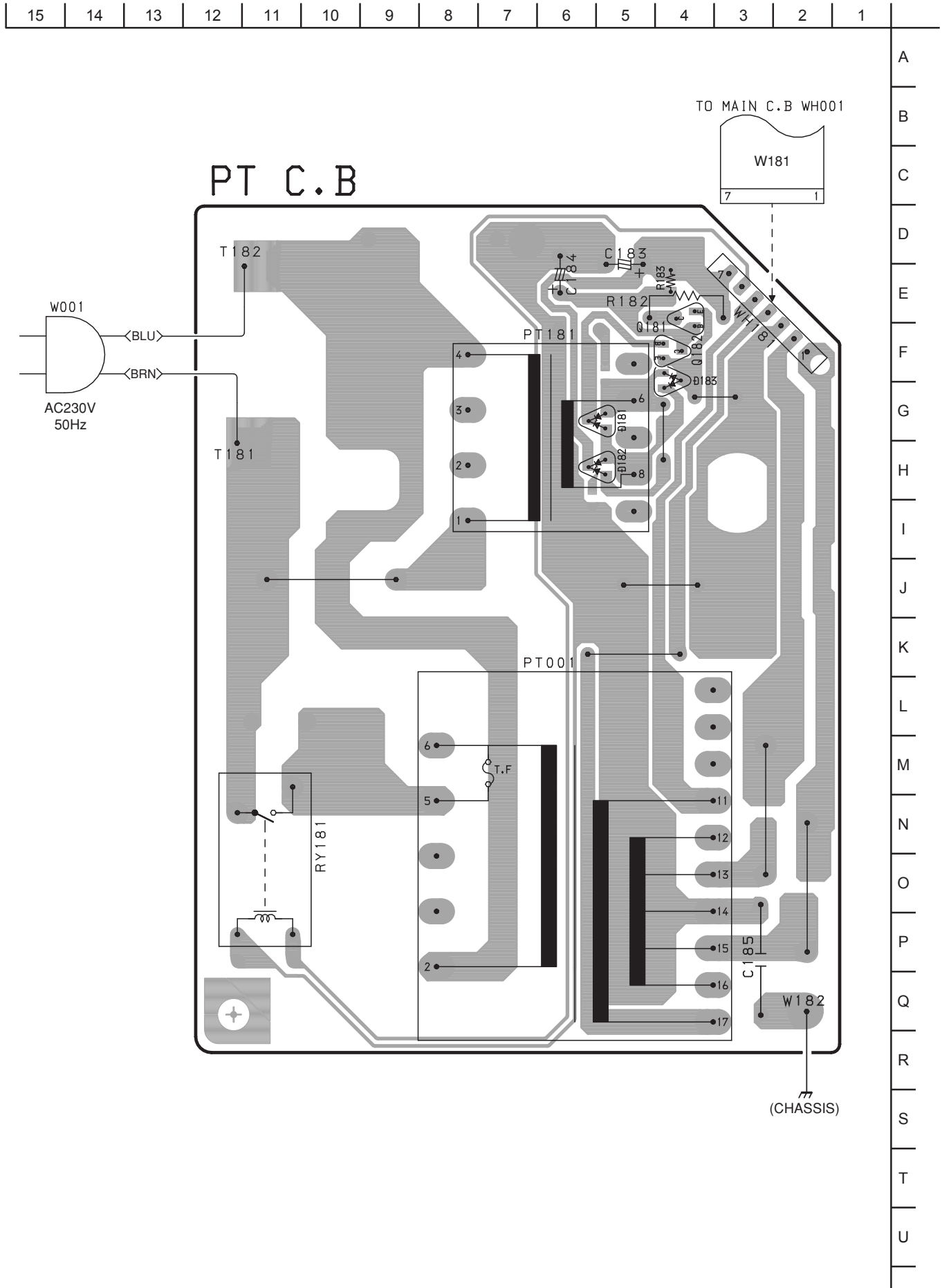

IC BLOCK DIAGRAM -1/2

IC, LC72131D-N

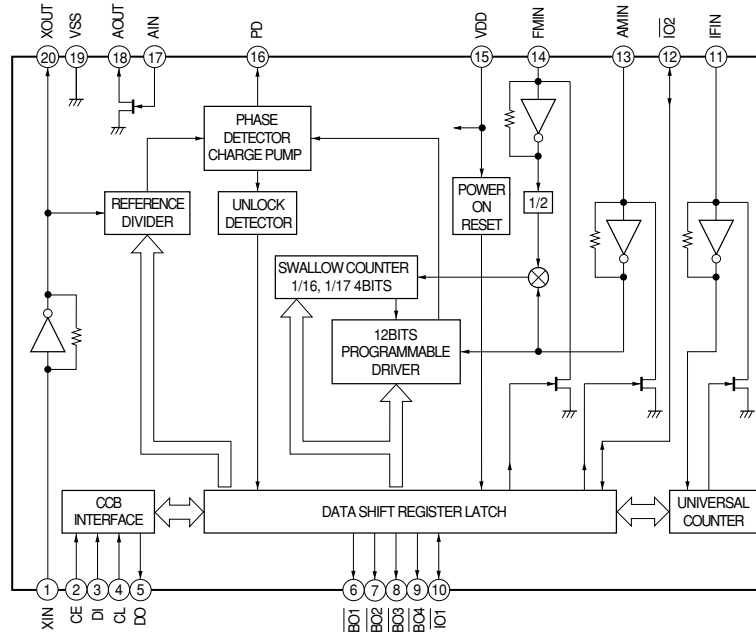

IC, M62495AFP

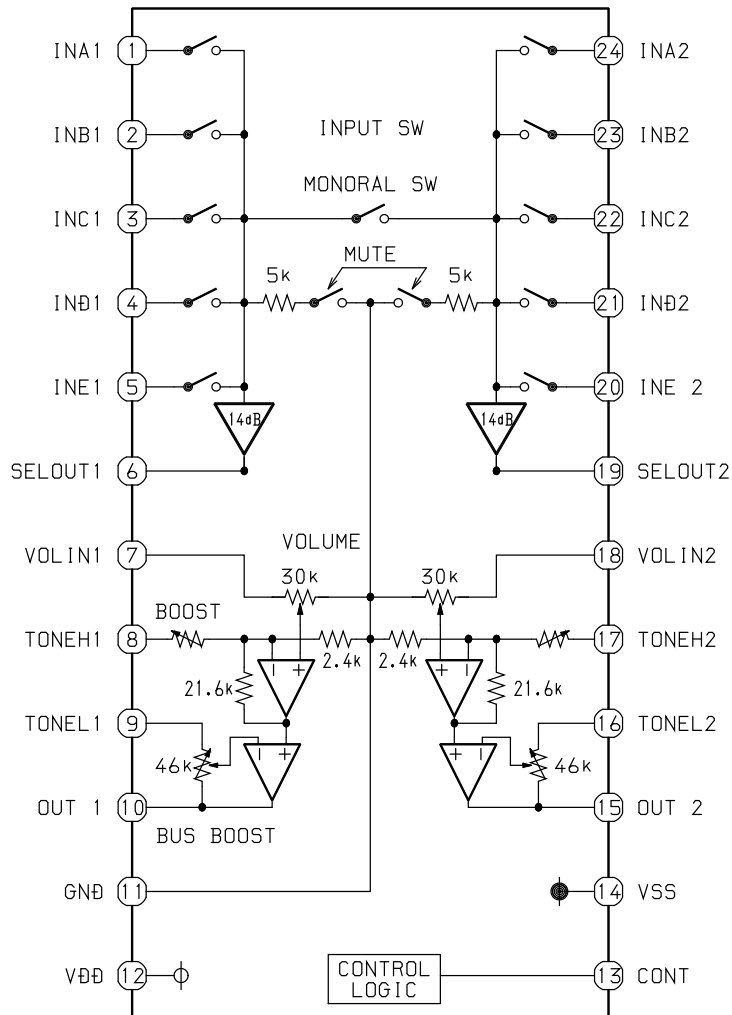

IC BLOCK DIAGRAM -2/2

IC, LA1845L

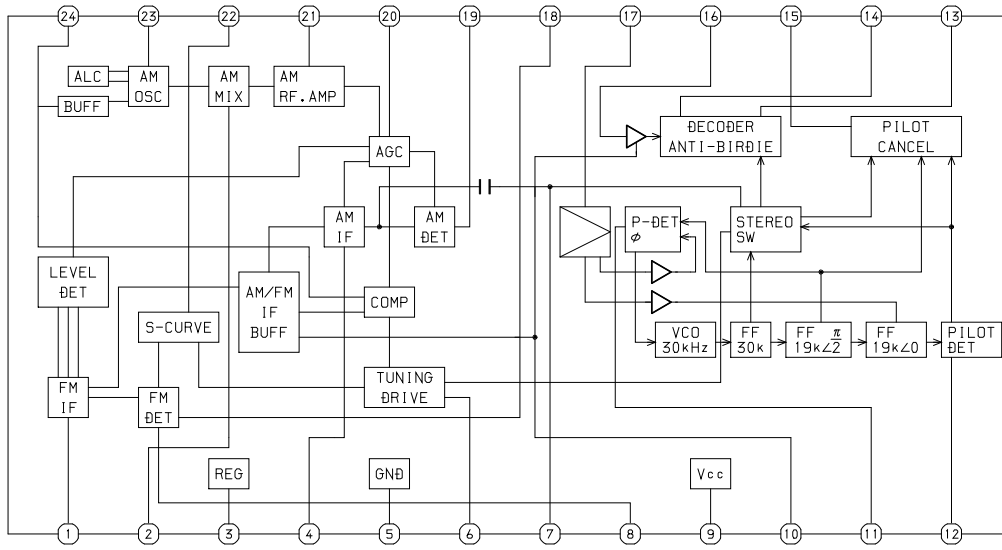

IC, BU1920FS

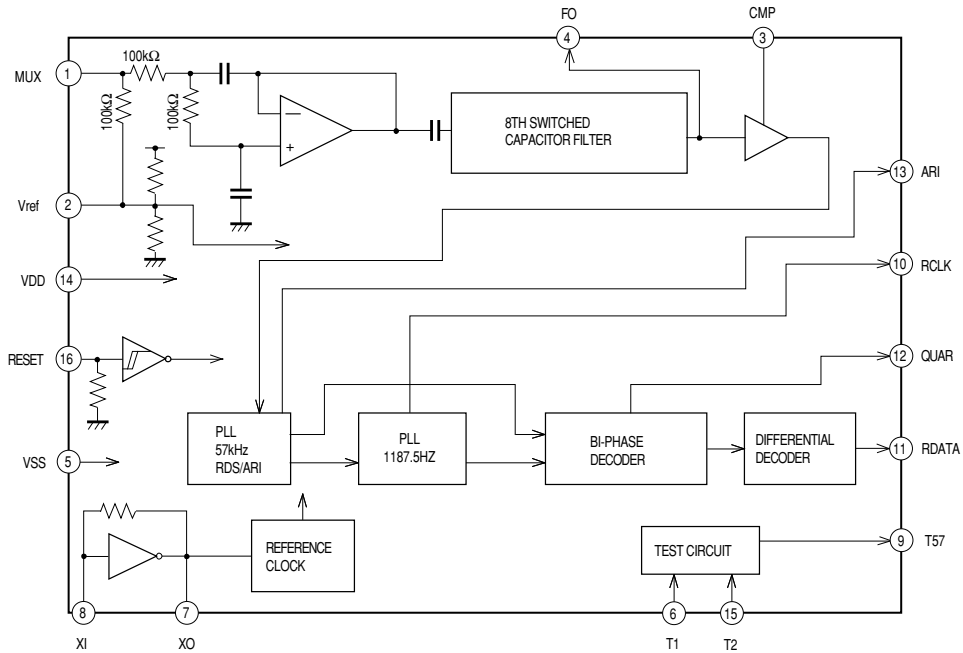

IC DESCRIPTION -1/1 (M38B57MCH-E236FP/M38B59MFH-E251FP) -1/2

Pin No.	Pin Name	I/O	Description
1	I-SIG	I	RDS signal level A/D input. (Not used)
2	I-HOLD	I	Hold voltage level A/D input.
3	I-SW (CD)	I	CD mecha SW A/D input.
4	I-DISH	I	CD turn-table position check A/D input.
5	I-KEY2	I	KEY2 A/D input.
6	I-KEY1	I	KEY1 A/D input.
7	I-RDS-DATA/ (O-DSP_DATA)	I/O	RDS data input/DSP IC data (V-CD) output. (Not used)
8	O-MOTOR	O	Deck motor supply ON/OFF output.
9	I-RMC	I	System remote control signal input. ("L"=ACTIVE)
10	RESET	I	System reset input. ("L"=RESET)
11	I-STEREO	I	Tuner stereo input. ("L"=STEREO)
12	O-DSC/O-PLL_DATA	O	Function IC control & PLL data output.
13	VSS	—	GND.
14, 15	XIN, XOUT	I/O	4.19MHz system CLK input/output.
16	VCC	—	Power supply input.
17	O-PB1	O	Deck 1/2 switch output. ("L"=PLAYBACK DECK 1)
18	O-STBY	O	Standby LED ON/OFF output. ("L"=ON)
19	O-RMT	O	REC mute output. ("H"=MUTE)
20	O-BIAS	O	Record bias ON/OFF output. ("L"=ON)
21	O-TU_ON	O	Tuner supply ON/OFF output. ("H"=ON)
22	O-CD_ON	O	CD supply ON/OFF output. ("H"= ON)
23	O-C.SHIFT	O	MICON clock shift output. ("L"=SHIFT)
24	O-PLL-CLK	O	PLL IC CLK output.
25	I-TM_BASE	I	8 Hz time base input.
26	O-CLOSE	O	CD door close output.
27	O-CD-OPEN	O	CD door open output.
28	VEE	—	Power supply input for FL display.
29	O-STB (DSP)	O	DSP IC strobe output. (Not used)
30	K-SCAN	O	Initial key scan output.
31	O-PLL_CE	O	CD PLL IC chip enable output.
32	O-CD_LED	O	CD flash window LED output.
33-42	G10-G1	O	FL grid output (G10-G1).
43	P22	O	FL segment output (P22). (Not used)
44-58	P21-P7	O	FL segment output (P21-P7).
59	PHONO/P6	I/O	PHONO diode input/FL segment output (P6).
60	CASINO DEMO/P5	I/O	CASINO DEMO diode input (Not used)/FL segment output (P5).
61	NON-ECO/P4	I/O	ECO OFF diode input/FL segment output (P4).
62	I-TU3/P3	I/O	TU 3 diode input (Not used)/FL segment output (P3).
63	I-TU2/P2	I/O	TU 2 diode input (Not used)/FL segment output (P2).
64	I-TU1/P1	I/O	TU 1 diode input (Not used)/FL segment output (P1).

IC DESCRIPTION -1/1 (M38B57MCH-E236FP/M38B59MFH-E251FP) -2/2

Pin No.	Pin Name	I/O	Description
65	O-DISH_R	O	CD turn-table reverse turn output.
66	O-DISH_F	O	CD turn-table forward turn output.
67	I-SUBQ	I	Sub code-Q data input.
68	O-CD_CE	O	CD DSP chip enable output.
69	I-WRQ	I	CD WRQ input.
70	O-CLK (CD)	O	CD control clock output .
71	O-DATA (CD)	O	CD control data output.
72	I-TUNE/IFC	I	Tuner SD input/IF count input.
73	AVSS	—	GND.
74	VREF	—	Reference voltage.
75	I-DRF	I	CD DRF input.
76	I-RDS_CLK	I	RDS clock input. (Not used)
77	I-LEVEL	I	Connected to GND through a resistor.
78	O-POWER	O	SYSTEM Power ON/OFF output. (“H”=ON)
79	I-RE_VOL	I	Rotary encoder A/D input.
80	I-TP_SW	I	Deck mecha SW A/D input.

MAIN C.B

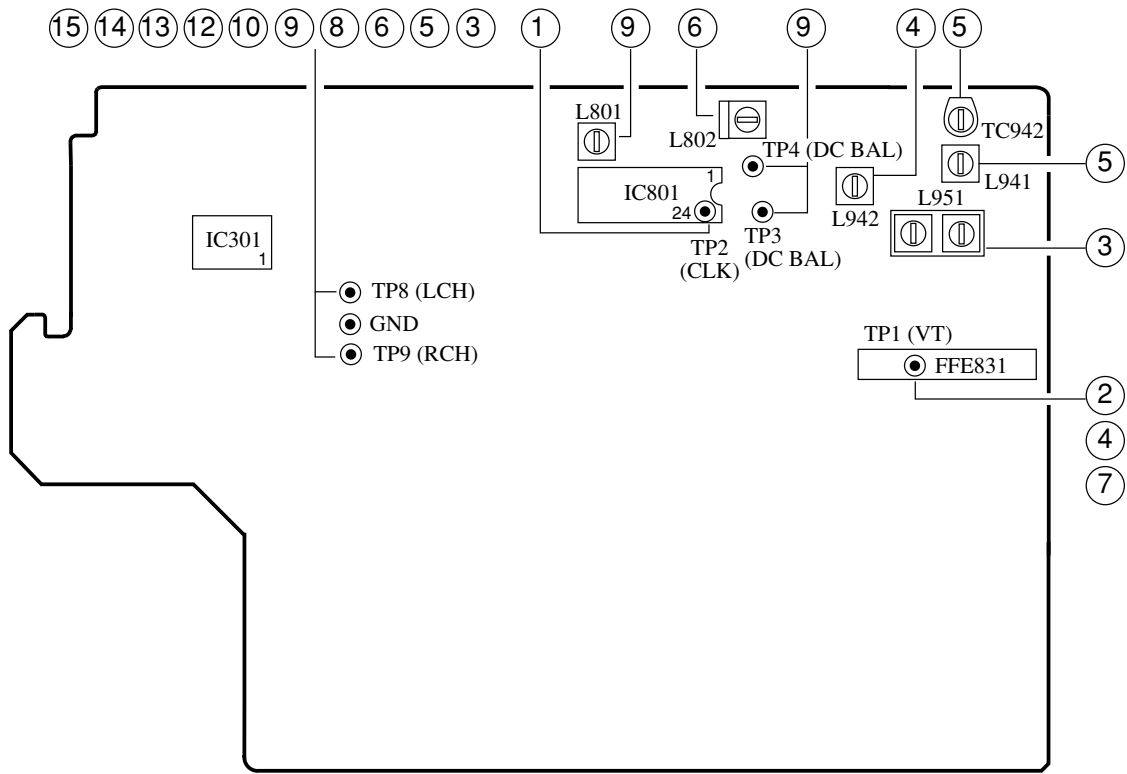

DECK-1 R/P/E, DECK-2 P HEAD

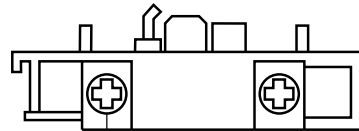

11
FWD

FRONT C.B

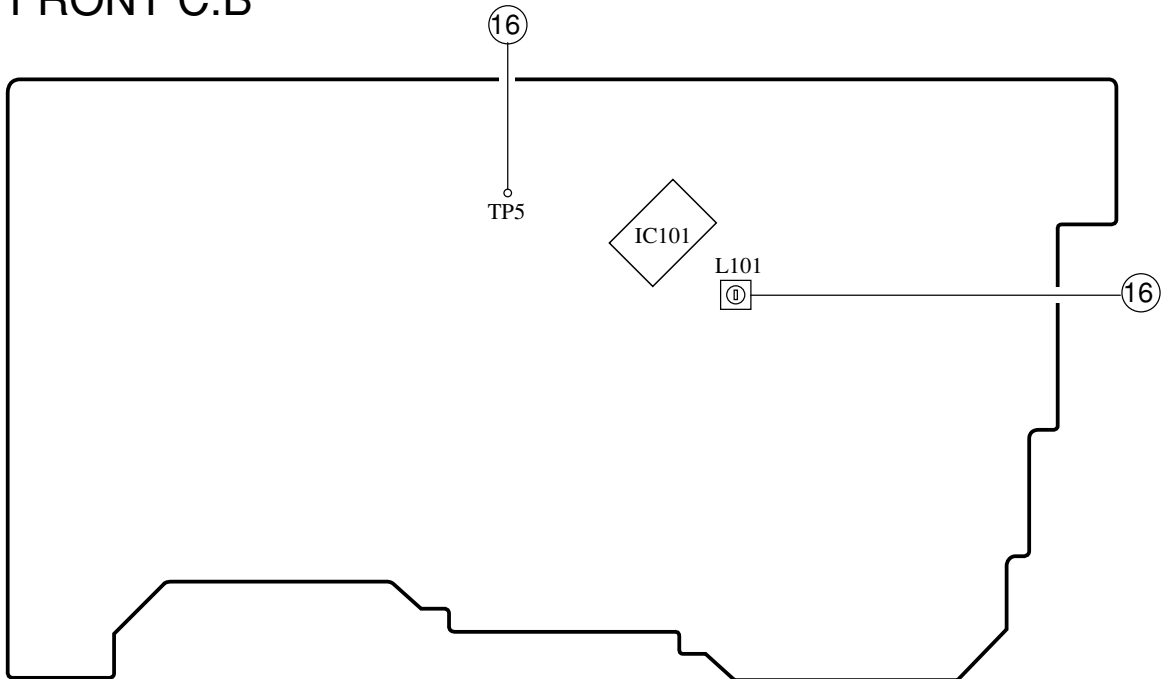

ADJUSTMENT -2/2

< TUNER SECTION >

1. Clock Frequency Check
Settings: • Test point: TP2 (CLK)
Method: Set to MW 1602kHz and check that the test point is 2052kHz±45Hz.
2. MW VT Check
Settings: • Test point: TP1 (VT)
Method: Set to MW 1602kHz and check that the test point is less than 8.0V. Then set to MW 531kHz and check that the test point is more than 0.6V.
3. MW Tracking Adjustment
Settings: • Test point: TP8 (Lch), TP9 (Rch)
• Adjustment location: L951 (1/3)
Method: Set to MW 999kHz and adjust L951 (1/3) so that the test point becomes maximum.
4. LW VT Adjustment
Settings: • Test point: TP1 (VT)
• Adjustment location: L942
Method: Set to LW 144kHz and adjust L942 so that the test point becomes 1.3V±0.05V.
Then set to LW 290kHz and check that the test point is less than 8.0V.
5. LW Tracking Adjustment
Settings: • Test point: TP8 (Lch), TP9 (Rch)
• Adjustment location:
L941 144kHz
TC942 290kHz
Method: Set up TC942 to center before adjustment.
The level at 144kHz is adjusted to maximum by L941.
Then the level at 290kHz is adjusted to maximum by TC942.
6. AM IF Adjustment
Settings: • Test point: TP8 (Lch), TP9 (Rch)
• Adjustment location:
L802 450kHz
7. FM VT Check
Settings: • Test point: TP1 (VT)
Method: Set to FM 108.0MHz and check that the test point is less than 8.0V (V model: 9.5V). Then set to FM 87.5MHz (V model: 65.0MHz) and check that the test point is more than 0.5V (V model: 1.0V).
8. FM Tracking Check
Settings: • Test point: TP8 (Lch), TP9 (Rch)
Method: Set to FM 98.0MHz and check that the test point is less than 13dBµV (V model: 8dBµV).
9. DC Balance/Mono Distortion Adjustment
Settings: • Test point: TP3, TP4 (DC balance)
TP8 (Lch), TP9 (Rch) (Distortion)
• Adjustment location: L801
• Input level: 60dBµV
Method: Set to FM 98.0MHz and adjust L801 so that the voltage between TP3 and TP4 becomes 0V±0.04V.
Next, check that the distortion is less than 1.3%.

< DECK SECTION >

10. Tape Speed Adjustment (DECK 1)
Settings: • Test tape: TTA-100
• Test point: TP8 (Lch), TP9 (Rch)
• Adjustment location: SFR701
Method: Play back the test tape and adjust SFR701 so that the frequency counter reads 3000Hz±5Hz.
 11. Head Azimuth Adjustment (DECK 1, DECK 2)
Settings: • Test tape: TTA-330
• Test point: TP8 (Lch), TP9 (Rch)
• Adjustment location: Head azimuth adjustment screw
Method: Play back (FWD) the 8kHz signal of the test tape and adjust screw so that the output becomes maximum.
Next, perform on REV PLAY mode.
 12. PB Frequency Response Check (DECK 1, DECK 2)
Settings: • Test tape: TTA-330
• Test point: TP8 (Lch), TP9 (Rch)
Method: Play back the 315Hz and 8kHz signals of the test tape and check that the output ratio of the 8kHz signal with respect to that of the 315Hz signal is within 4dB.
 13. PB Sensitivity Check (DECK 1, DECK 2)
Settings: • Test tape: TTA-200
• Test point: TP8 (Lch), TP9 (Rch)
Method: Play back the test tape and check that the output level of the test point is 110mV±3.5dB.
 14. REC/PB Frequency Response Check (DECK 1)
Settings: • Test tape: TTA-602
• Test point: TP8 (Lch), TP9 (Rch)
• Input signal: 1kHz/8kHz (LINE IN)
Method: Apply a 1kHz signal and REC mode. Then adjust OSC attenuator so that the output level at the test points becomes -20VU. Record and play back the 1kHz and 8kHz signals and check that the output of the 8kHz signals is 0dB±5dB with respect to that of the 1kHz signal.
 15. REC/PB Sensitivity Check (DECK 1)
Settings: • Test tape: TTA-602
• Test point: TP8 (Lch), TP9 (Rch)
• Input signal: 1kHz (LINE IN)
Method: Apply a 1kHz signal and REC mode. Then adjust OSC attenuator so that the output level at TP8, TP9 becomes 0VU. Record and play back the 1kHz signals and check that the output is -2dB±3.5dB.
- ### < FRONT SECTION >
16. u-CON OSC Adjustment
Settings: • Test point: TP5
• Adjustment location: L101
Method: Insert AC plug with pressing of TUNER function key and POWER key. Adjust L101 so that the frequency across the test point is 58.350Hz±0.02Hz.

GRID ASSIGNMENT

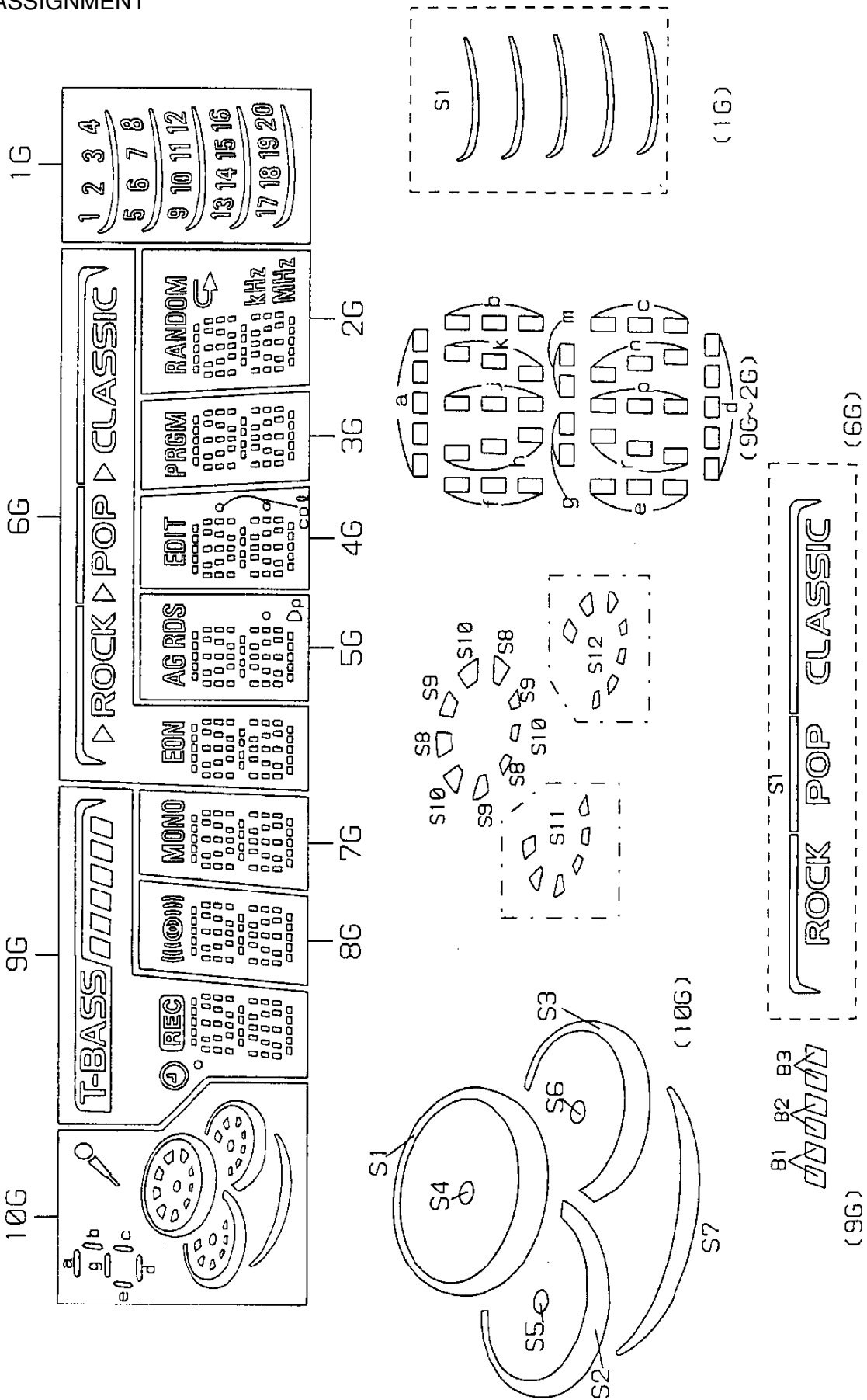

ANODE CONNECTION

	10G	9G	8G	7G	6G	5G	4G	3G	2G	1G
P1	-	d	d	c	d	d	d	d	d	20
P2	S7	n	n	n	n	n	n	n	n	19
P3	-	p	p	p	p	p	p	p	p	18
P4	S11	r	r	r	r	r	r	r	r	17
P5	S5	e	e	e	e	e	e	e	e	16
P6	S2	c	c	c	c	c	c	c	c	15
P7	S12	g	g	g	g	g	g	g	g	14
P8	S6	n	m	m	m	m	m	m	m	13
P9	S3	f	f	f	f	f	f	f	f	12
P10	S10	b	b	b	b	b	b	b	b	11
P11	S9	k	k	k	k	k	k	k	k	10
P12	S8	J	J	J	J	J	J	J	J	9
P13	S4	h	h	h	h	h	h	h	h	8
P14	S1	a	a	a	a	a	a	a	a	7
P15	-	Ⓟ	(((CO)))	MONO	EON	Dp	col (F)	-	MHZ	6
P16	-	(REG)	-	-	-	AG	col (±)	-	KHZ	5
P17	🔑	○	-	-	▷ (CLASSIC)	RDS	EDIT	PRGM	↩	4
P18	a, d, g	BASE	-	-	▷ (ROCK)	-	-	-	-	3
P19	b	B1	-	-	▷ (POP)	-	-	-	-	2
P20	c	B2	-	-	S1	-	-	-	RANDOM	1
P21	e	B3	-	-	-	-	-	-	-	SI

MECHANICAL EXPLODED VIEW -1/1

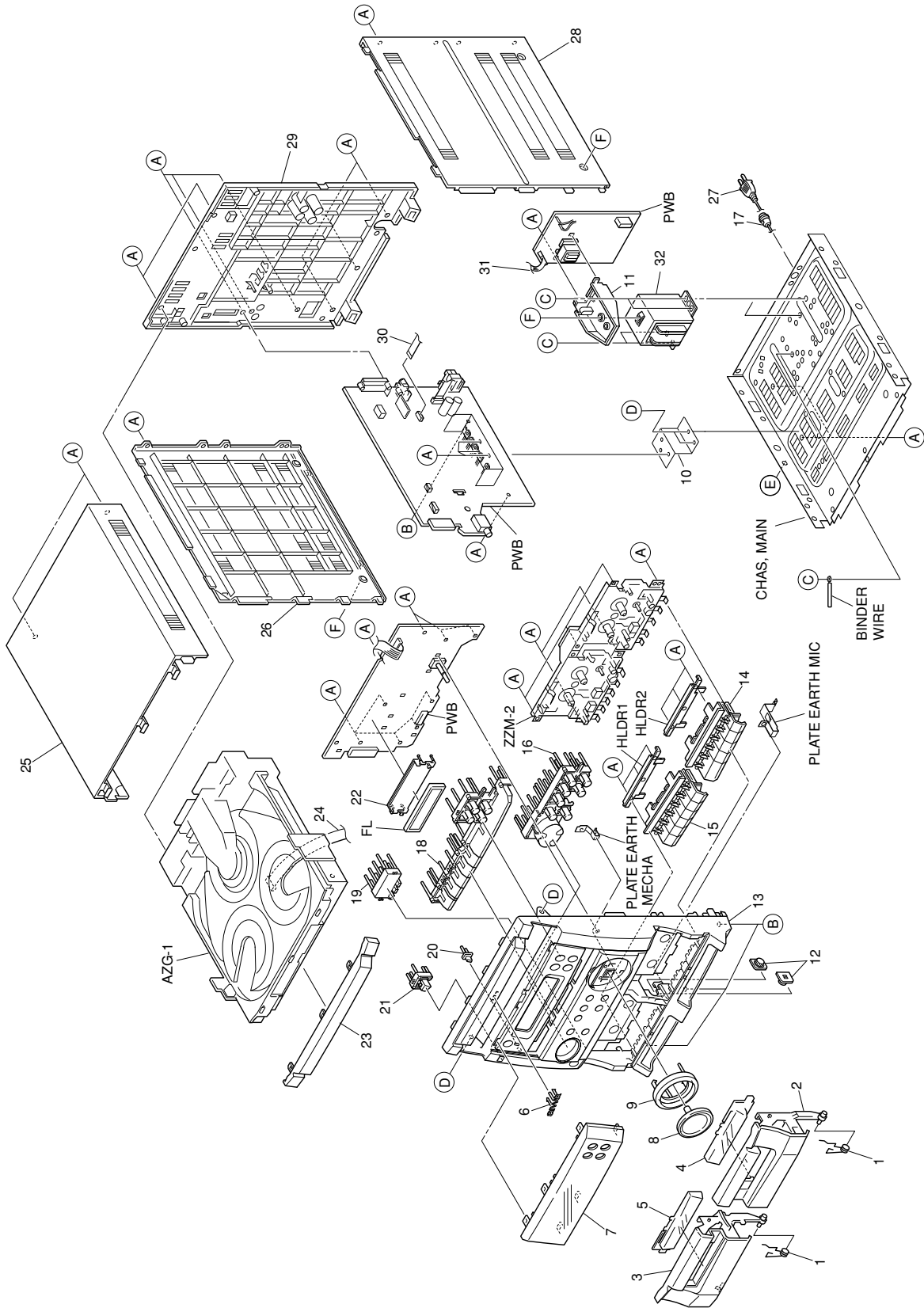

MECHANICAL MAIN PARTS LIST 1/1

REF. NO	PART NO.	KANRI NO.	DESCRIPTION
1	82-NF7-218-010		SPR-T, CASS
2	8A-NFA-004-010		BOX, CASS 2
3	8A-NFA-003-010		BOX, CASS 1
4	8A-NFA-007-010		WINDOW, CASS 2
5	8A-NFA-006-010		WINDOW, CASS 1
6	87-B00-002-010		BADGE, AIWA 30 ABS SIL<NDR3>
6	87-CE3-023-010		BADGE, AIWA 30N SILV<NDR2>
7	8A-NFB-004-010		WINDOW, DISP EZ DR2<NDR2>
7	8A-NFB-005-010		WINDOW, DISP EZ DR3<NDR3>
8	8A-NFA-011-110		KNOB, RTRY VOL
9	8A-NFA-012-010		RING, VOL
10	8A-NFB-202-010		HLDR, HT-SINK S STEEL
△	11	8A-NF9-211-010	HLDR, FWB PT HI
	12	86-NFZ-231-010	DMPR, 70
	13	8A-NFA-042-210	CABI, FR EZ<NDR2>
	13	8A-NFA-091-210	CABI, FR K<NDR3>
	14	8A-NFA-014-110	KEY, CASS 2P
	15	8A-NFA-013-210	KEY, CASS 1
	16	8A-NFA-010-110	KEY, OPE
△	17	87-085-185-010	BUSHING, AC CORD (E) CM-22B
	18	8A-NFA-009-010	KEY, FUN
	19	8A-NFA-016-010	KEY, RDS<NDR2>
	20	8A-NFA-018-010	REFLECTOR, ECO
	21	8A-NFA-008-010	KEY, POWER
	22	8A-NFA-208-010	GUIDE, FL 100-25 ANFA
	23	8A-NFA-002-010	PANEL, TRAY H
	24	88-913-221-110	FF-CABLE, 13P 1.25 220MM
	25	8A-NFA-062-010	PANEL, TOP V-2
	26	8A-NFA-067-010	PANEL, RIGHT V-2 PL
△	27	87-A80-157-010	AC CORD ASSY, E BLK CC
	28	8A-NFA-063-010	PANEL, LEFT V-2
	29	8A-NFB-017-010	CABI, REAR EZ W/O SPEC
	30	88-906-181-110	FF-CABLE, 6P 1.25
	31	8A-NFA-628-010	F-CABLE, 7P 2.5 260MM
△	32	8A-NFB-611-010	PT, ANF-B EZ LOW
	A	87-067-703-010	BVT2+3-10 W/O SLOT
	B	87-NF4-224-010	S-SCREW, IT3B+3-8 CU
	C	87-078-200-010	S-SCREW, ITC4+4-8 R
	D	87-721-097-410	QT2+3-12 W/O SLOT
	E	87-067-688-010	BVTT+3-6
	F	87-067-641-010	UTT2+3-8 W/O SLOT BLK

COLOR NAME TABLE

Basic color symbol	Color	Basic color symbol	Color	Basic color symbol	Color
B	Black	C	Cream	D	Orange
G	Green	H	Gray	L	Blue
LT	Transparent Blue	N	Gold	P	Pink
R	Red	S	Silver	ST	Titan Silver
T	Brown	V	Violet	W	White
WT	Transparent White	Y	Yellow	YT	Transparent Yellow
LM	Metallic Blue	LL	Light Blue	GT	Transparent Green
LD	Dark Blue	DT	Transparent Orange	GM	Metallic Green
YM	Metallic Yellow	DM	Metallic Orange	PT	Transparent Pink
LA	Aqua Blue	GL	Light Green	HT	Transparent Gray
HM	Metallic Gray	NH	Champagne Gold	M	Wood Pattern

TAPE MECHANISM EXPLODED VIEW -1/1 (ZZM-2 PRINNM/PRINC)

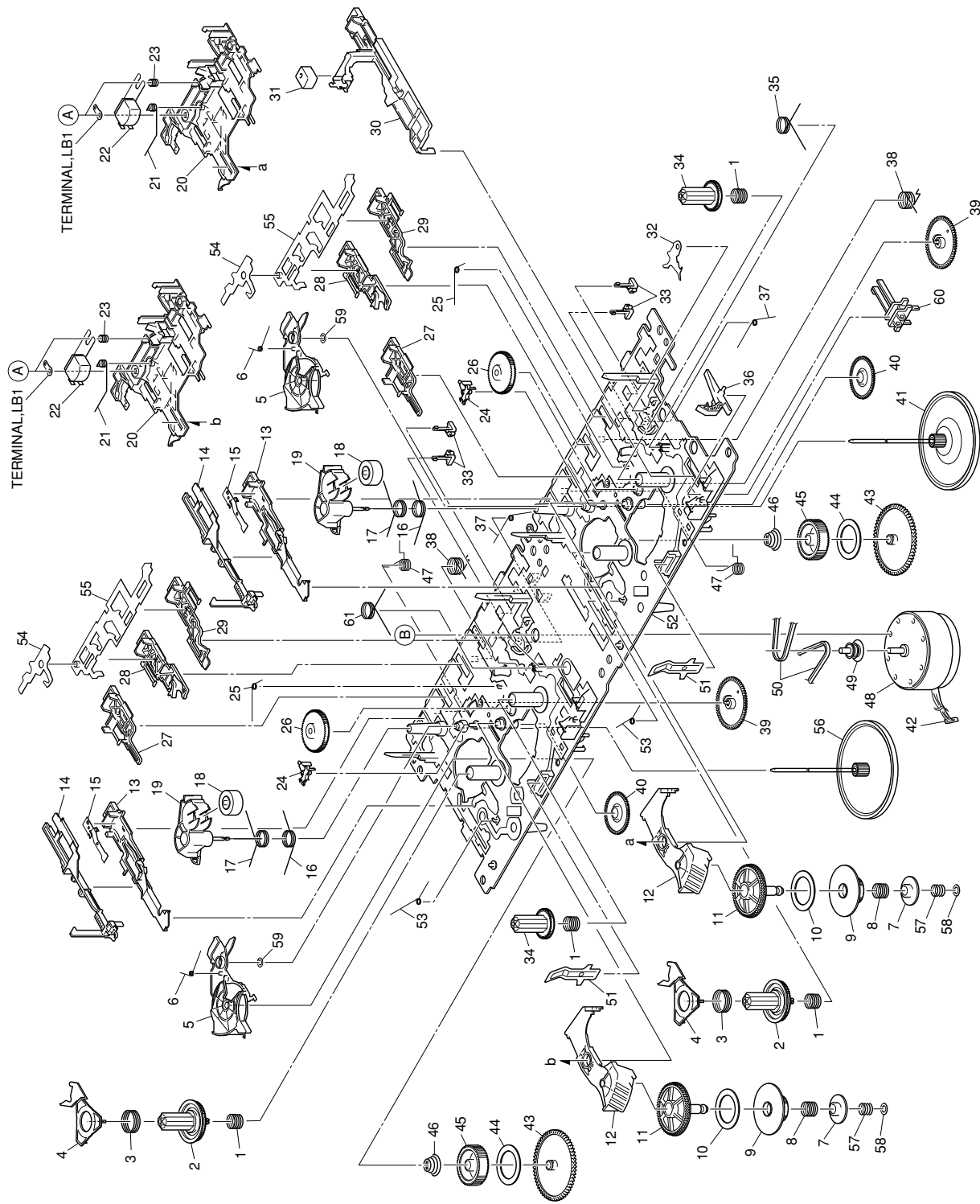

TAPE MECHANISM PARTS LIST -1/1 (ZZM-2 PRINM/PRINC)

REF. NO	PART NO.	KANRI NO.	DESCRIPTION	REF. NO	PART NO.	KANRI NO.	DESCRIPTION
1	8Z-ZM1-254-210		SPR-C, REEL R	36	8Z-ZM1-220-110		LEVER, REC SENSOR
2	8Z-ZM1-225-110		GEAR, REEL R	37	8Z-ZM1-249-010		SPR-T, FR
3	8Z-ZM1-253-110		SPR-C, AUTO SENSOR	38	8Z-ZM1-242-110		SPR-T, FF/REW
4	8Z-ZM1-217-110		LEVER, AUTO SENSOR	39	8Z-ZM1-229-010		GEAR, CAM
5	8Z-ZM1-212-110		LEVER, T-UP	40	8Z-ZM1-232-010		GEAR, IDL FF/REW
6	8Z-ZM1-245-010		SPR-T, AUTO	41	8Z-ZM1-234-010		FLY-WHL, ZZM-1
7	8Z-ZM1-236-010		CLR, SLIP FF/REW	42	8Z-ZM1-267-010		SHAFT, CAPSTAN 2
8	8Z-ZM1-252-010		SPR-C, FF/REW	43	8Z-ZM1-228-010		GEAR, SLIP T-UP B
9	8Z-ZM1-230-010		GEAR, SLIP FF/REW A	44	8Z-ZM1-265-010		FELT, T-UP
10	8Z-ZM1-269-010		FELT, FF/REW 2	45	8Z-ZM1-227-010		GEAR, SLIP T-UP A
11	8Z-ZM1-238-110		GEAR, SLIP FF/REW B 2	46	8Z-ZM1-251-110		SPR-C, T-UP SLIP
12	8Z-ZM1-237-010		LEVER, FF/REW 2	47	8Z-ZM1-243-210		SPR-T, STOP/PAUSE
13	8Z-ZM1-209-210		LEVER, PAUSE	48	87-A91-532-010		MOT, MS15U2LW1A
14	8Z-ZM1-218-110		LEVER, E-LOCK H	49	8Z-ZM1-235-010		PULLEY, MOT
15	8Z-ZM1-256-010		SPR-P, PAUSE	50	8Z-ZM2-216-010		BELT, MAIN M
16	8Z-ZM1-244-010		SPR-T, T-UP	51	8Z-ZM1-260-010		SPR-P, CASSETTE
17	8Z-ZM1-247-210		SPR-T, PINCH	52	8Z-ZM2-201-010		CHAS ASSY, ZZM-2
18	8Z-ZM1-261-110		ROLLER ASSY, PINCH	53	8Z-ZM1-255-110		SPR-T, E-LOCK
19	8Z-ZM1-221-010		LEVER, PINCH	54	8Z-ZM2-219-010		LEVER, E-OPEN ZZM-2
20	8Z-ZM1-205-210		LEVER, PLAY	55	8Z-ZM1-214-110		LEVER, LOCK
21	8Z-ZM1-248-110		SPR-T, BRG	56	8Z-ZM2-211-010		FLY-WHL, ZZM-2
22	87-A90-403-110		HEAD, RPH MS15R	57	8Z-ZM1-257-110		SPR-C, F/R
23	84-ZM2-227-310		SPR-C, AZIMUTH	58	8Z-ZM1-275-010		W-L, 1.47-4-0.25
24	8Z-ZM1-216-010		LEVER, AUTO	59	80-ZM6-243-010		SH 1.75-3.6-0.5 SLT
25	8Z-ZM1-246-010		SPR-T, AUTO 2	60	87-A91-494-010		SW, LEAF MSW17820
26	8Z-ZM2-214-010		GEAR, IDL REW ZZM-2	61	8Z-ZM1-241-010		SPR-T, PLAY
27	8Z-ZM2-212-010		LEVER, STOP ZZM-2	62	8Z-ZM2-601-010		CONN ASSY, 9P ZZM-2
28	8Z-ZM1-207-010		LEVER, FF	A	84-ZM2-242-010		S-SCREW, AZ1-2-6.4
29	8Z-ZM1-206-010		LEVER, REW	B	8Z-ZM2-220-110		V+2.6 ZZM-2
30	8Z-ZM1-210-010		LEVER, REC				
31	87-A90-404-010		HEAD, EH LE15B				
32	8Z-ZM2-218-010		LEVER, REC LOCK ZZM-2				
33	87-A91-492-010		SW, LEAF MSW18560				
34	8Z-ZM1-226-010		GEAR, REEL L				
35	8Z-ZM1-241-010		SPR-T, PLAY				

SPEAKER DISASSEMBLY INSTRUCTIONS

Type.1

Insert a flat-bladed screwdriver into the position indicated by the arrows and remove the panel. Remove the screws of each speaker unit and then remove the speaker units.

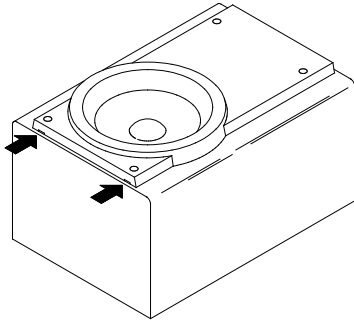

Type.2

Remove the grill frame and four pieces of rubber caps by pulling out with a flat-bladed screwdriver. Remove the screws from hold where installed rubber caps. Insert a flat-bladed screwdriver into the position indicated by the arrows and remove the panel. Remove the screws of each speaker unit and then remove the speaker units.

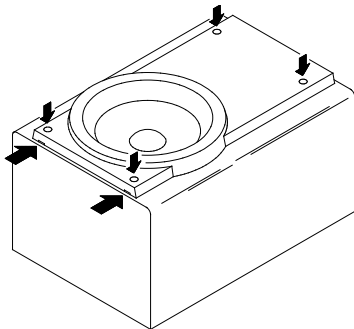

Type.3

Insert a flat-bladed screwdriver into the position indicated by the arrows and remove the panel. Turn the speaker unit to counterclockwise direction while inserting a flat-bladed screwdriver into one of the hollows around speaker unit, and then remove the speaker unit. After replacing the speaker unit, install it turning to clockwise direction until "click" sound comes out.

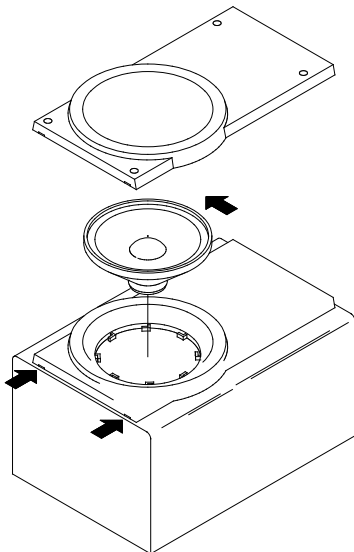

Type.4

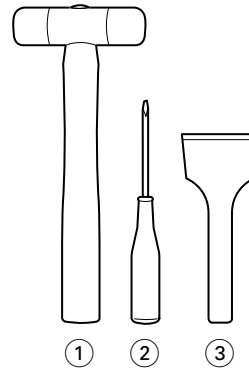

TOOLS

- ① Plastic head hammer
- ② (⊖) flat head screwdriver
- ③ Cut chisel

How to Remove the PANEL, FR

1. Insert the (⊖) flat head screwdriver tip into the gap between the PANEL, FR and the PANEL, SPKR. Tap the head of the (⊖) flat head screwdriver with the plastic hammer head, and create the clearance as shown in Fig-1.
2. Insert the cut chisel in the clearance, and tap the head of the cut chisel with plastic hammer as shown in Fig-2, to remove the PANEL, FR.
3. Place the speaker horizontally. Tap head of the cut chisel with plastic hammer as shown in Fig-3, and remove the PANEL, FR completely.

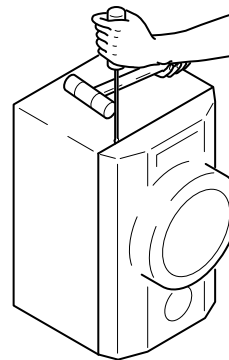

Fig-1

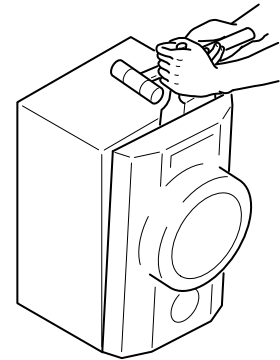

Fig-2

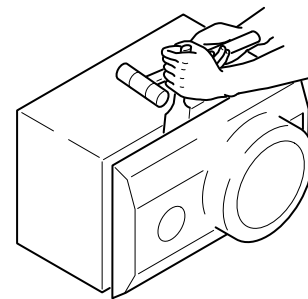

Fig-3

How to Attach the PANEL, FR

Attach the PANEL, FR to the PANEL, SPKR. Tap the four corners of the PANEL, FR with the plastic hammer to fit the PANEL, FR into the PANEL, SPKR completely.

SPEAKER PARTS LIST -1/1

REF. NO	PART NO.	KANRI NO.	DESCRIPTION
1	8A-NSL-001-010		PANEL, FR
2	8A-NSL-003-010		GRILLE, FRAME ASSY<EXCEPT NSZ7YSC1>
2	8A-NSL-021-010		GRILLE, FRAME ASSY L<NSZ7YSC1>
3	8Z-NSL-601-110		SPKR, W 120<NSZ5YSC9>
3	8A-NSL-606-010		SPKR, W 120<EXCEPT NSZ5YSC9, NSZ7YSC9>
3	8Z-NSL-603-010		SPKR, W 120<NSZ7YSC9>
4	87-NS7-611-010		CORD, SPKR<NSZ5YSC9, NSZ7YSC9>
4	8A-NSL-017-010		CORD, SPKR ASSY<EXCEPT NSZ5YSC9, NSZ7YSC9>



アイワ株式会社 〒110-8710 東京都台東区池之端1-2-11 ☎03(3827)3111 (代表)
AIWA CO.,LTD. 2-11, IKENOHATA 1-CHOME, TAITO-KU, TOKYO 110, JAPAN TEL:03 (3827) 3111
