

aiwa



NSX-MA545

COMPACT DISC STEREO SYSTEM

- BASIC TAPE MECHANISM: 6ZM-3 PR1NM
- BASIC CD MECHANISM: 4ZG-1 Z3RDSHM

• TYPE: U

SIMPLE MANUAL

- Replace this Service Manual with "Revision Publishing" when it is issued.

S/M Code No. 09-98C-323-0T1

MANUAL
SERVICE

ELECTRICAL PARTS LIST-1/7

NOTE: The characters in the suffix column indicate the part usage.

REF.NO	PARTS NO.	DESCRIPTION	SUFFIX	
USTMXX	A.....	
		KANRI		
		NO.		
C	503	87-010-112-040	CAP,E 100-16	AB.....
C	502	87-010-186-080	CAP,CHIP 4700P	AB.....
C	506	87-010-320-080	CHIP CAP 68P	AB.....
C	504	87-010-405-040	CAP,E 10-50	AB.....
C	507	87-010-544-040	CAP,E 0.1-50 SME	AB.....
C	509	87-010-544-040	CAP,E 0.1-50 SME	AB.....
C	505	87-010-546-040	CAP,E 0.33-50	AB.....
J	501	87-A60-651-010	JACK,3.5MONO	AB.....
Q	504	87-A30-075-080	C-TR,2SA1235F	AB.....
Q	505	87-A30-076-080	C-TR,2SC3052F	AB.....
Q	501	87-A30-087-080	C-FET,2SK2158	AB.....
VR	501	87-NE7-602-010	VR,RTRY 10KAX1 1 V	AB.....
		8Z-NF8-661-010	PT,SUB ZNF-8(U)	A.....
		8Z-NF8-662-010	PT,SUB ZNF-8(E)
		8Z-NF8-663-010	PT,SUB ZNF-8(H)
C	1	87-010-388-080	CAP ELECT 1000-25V SME	AB.....
C	9	87-010-917-090	CAP,E 3300-50 M SMG	AB.....
C	8	87-010-917-090	CAP,E 3300-50 M SMG	AB.....
C	5	87-018-209-010	CAP 0.1	AB.....
C	3	87-018-209-010	CAP 0.1	AB.....
C	4	87-018-209-010	CAP 0.1	AB.....
CN	1	87-A60-851-010	CONN,9P V VH	AB.....
D	6	87-017-447-010	DIODE,GBU4DL	AB.....
D	4	87-020-465-080	DIODE,1SS133 (110MA)	AB.....
D	3	87-020-465-080	DIODE,1SS133 (110MA)	AB.....
D	2	87-020-465-080	DIODE,1SS133 (110MA)	AB.....
D	5	87-020-465-080	DIODE,1SS133 (110MA)	AB.....
D	1	87-020-465-080	DIODE,1SS133 (110MA)	AB.....
RY	2	87-A90-976-010	RELAY,AC12V SDT-S-112LMR	A.....
RY	1	87-A91-281-010	RELAY,AC DC12V OSA-SS-212DM5	.B.....
T	1	87-A60-317-010	TERMINAL, 1P MSC	AB.....
T	2	87-A60-317-010	TERMINAL, 1P MSC	AB.....
		88-NF8-205-010	GUIDE,FL	AB.....
*		8Z-NF8-201-010	GUIDE,OPE	AB.....
*		8Z-NF8-202-010	GUIDE,FUN	AB.....
C	201	87-012-156-080	C-CAP,S 220P-50 CH	AB.....
C	254	87-010-194-080	CAP,CHIP 0.047	AB.....
C	252	87-010-198-080	CAP,CHIP 0.022	AB.....
C	259	87-015-699-040	CAP,E 10-50 7L	AB.....
C	256	87-015-699-040	CAP,E 10-50 7L	AB.....
C	251	87-015-699-040	CAP,E 10-50 7L	AB.....
C	255	87-A10-586-040	CAP,E 47-35 7L SR	AB.....
C	260	87-010-198-080	CAP,CHIP 0.022	AB.....
C	301	87-010-182-080	C-CAP,S 2200P-50 B	AB.....
C	302	87-010-182-080	C-CAP,S 2200P-50 B	AB.....
C	311	87-010-194-080	CAP,CHIP 0.047	AB.....
C	314	87-010-194-080	CAP,CHIP 0.047	AB.....
C	312	87-010-405-040	CAP,E 10-50	AB.....
C	324	87-010-194-080	CAP,CHIP 0.047	AB.....
C	323	87-010-248-040	CAP,E 220-10 SME	AB.....
C	325	87-010-263-040	CAP,E 100-10	AB.....
C	322	87-015-694-040	E/CAP 0.47-50	AB.....
C	332	87-010-198-080	CAP,CHIP 0.022	AB.....
C	334	87-010-312-080	C-CAP,S 15P-50 CH	AB.....
C	335	87-012-140-080	CAP 470P	AB.....
C	333	87-012-140-080	CAP 470P	AB.....
C	338	87-012-155-080	C-CAP 180P-50CH	AB.....
C	339	87-012-156-080	C-CAP,S 220P-50 CH	AB.....
C	340	87-010-197-080	CAP,CHIP 0.01 DM	AB.....
C	351	87-010-382-040	CAP,E 22-25 SME	AB.....
C	401	87-010-197-080	CAP,CHIP 0.01 DM	AB.....
C	457	87-010-196-080	CHIP CAPACITOR,0.1-25	AB.....
C	455	87-010-196-080	CHIP CAPACITOR,0.1-25	AB.....
C	456	87-012-158-080	C-CAP,S 390P-50 CH	AB.....
C	601	87-010-196-080	CHIP CAPACITOR,0.1-25	AB.....
C	604	87-010-322-080	C-CAP,S 100P-50 CH	AB.....
C	603	87-010-322-080	C-CAP,S 100P-50 CH	AB.....
C	602	87-010-322-080	C-CAP,S 100P-50 CH	AB.....
C	701	87-010-196-080	CHIP CAPACITOR,0.1-25	AB.....
CON	102	87-099-015-010	CONN,13P 6216V	AB.....
CON	101	87-099-720-010	CONN,30P TYK-B(P)	AB.....
CON	301	87-099-013-010	CONN,11P 6216 V	A.....
CON	301	87-099-017-010	CONN,15P 6216 V	.B.....
D	208	87-020-465-080	DIODE,1SS133 (110MA)	AB.....
D	311	87-A40-509-080	ZENER,MTZJ6.8C	AB.....
D	452	87-017-932-080	ZENER,MTJ6.2B	AB.....
EMI	201	87-008-372-080	FILTER,EMI BL OIRNI	AB.....
EMI	202	87-A50-322-080	C-COIL,S BK2125 LM252	AB.....
FL	401	8Z-NH8-603-010	FL,BJ674GNK	AB.....
IC	201	8Z-NF8-602-010	C-IC,UPD780228GF-031-3BA	AB.....
IC	251	87-A20-914-010	IC,SPS-442-1-F	AB.....
IC	451	87-A21-023-040	C-IC,BA3835F	AB.....
IC	601	87-A21-021-040	C-IC,BU2099FV	AB.....
L	331	87-A50-434-010	COIL,CLK 4.19M(TOKO)	AB.....
LED	311	87-A40-317-080	LED,SLR-342VCT31 RED	AB.....
LED	611	87-A40-619-080	LED,SLR-56PT-TE7-W GRN	AB.....

ELECTRICAL PARTS LIST-2/7

LED	634	87-A40-619-040	LED,SLR-56PT-T31-W GRN	AB.....
LED	633	87-A40-619-040	LED,SLR-56PT-T31-W GRN	AB.....
Q	207	87-A30-087-080	C-FET,2SK2158	AB.....
Q	251	87-A30-074-080	C-TR,RT1P 141C	AB.....
Q	301	87-A30-159-080	C-TR,KTA1298Y	AB.....
Q	302	87-A30-159-080	C-TR,KTA1298Y	AB.....
Q	303	87-A30-240-080	TR,CSA1585BC	AB.....
Q	311	87-026-610-080	TR,KTC3198GR	AB.....
Q	312	87-A30-087-080	C-FET,2SK2158	AB.....
Q	322	87-A30-073-080	C-TR,RT1N 141C	AB.....
Q	323	87-A30-087-080	C-FET,2SK2158	AB.....
S	434	87-A91-024-080	SW,TACT KSH0611BT	AB.....
SW	252	87-A90-535-010	SW,RTRY EC16B24304	AB.....
SW	253	87-A90-950-010	SW,RTRY EC12E12504 ENCORDER	AB.....
C	309	87-010-196-080	CHIP CAPACITOR,0.1-25	AB.....
C	302	87-010-318-080	C-CAP,S 47P-50 CH	AB.....
C	301	87-010-318-080	C-CAP,S 47P-50 CH	AB.....
C	305	87-012-145-080	CAP,CHIP S 270P CH	AB.....
C	306	87-012-145-080	CAP,CHIP S 270P CH	AB.....
C	303	87-012-157-080	C-CAP,S 330P-50 CH	AB.....
C	304	87-012-157-080	C-CAP,S 330P-50 CH	AB.....
C	315	87-010-178-080	CHIP CAP 1000P	.B.....
C	314	87-010-178-080	CHIP CAP 1000P	.B.....
C	316	87-010-178-080	CHIP CAP 1000P	.B.....
C	313	87-010-178-080	CHIP CAP 1000P	.B.....
C	314	87-010-180-080	C-CER 1500P	A.....
C	313	87-010-180-080	C-CER 1500P	A.....
C	316	87-010-182-080	C-CAP,S 2200P-50 B	A.....
C	315	87-010-182-080	C-CAP,S 2200P-50 B	A.....
C	310	87-010-196-080	CHIP CAPACITOR,0.1-25	AB.....
C	311	87-010-198-080	CAP,CHIP 0.022	AB.....
C	312	87-010-198-080	CAP,CHIP 0.022	AB.....
C	324	87-010-260-080	CAP,ELECT 47-25V	AB.....
C	325	87-010-370-080	CAP,E 330-6.3 SME	AB.....
C	327	87-010-404-080	CAP,ELECT 4.7-50V	AB.....
C	328	87-010-404-080	CAP,ELECT 4.7-50V	AB.....
C	321	87-016-492-080	C-CAP,S 0.33-16 FZ	AB.....
C	322	87-016-492-080	C-CAP,S 0.33-16 FZ	AB.....
C	336	87-010-401-080	CAP,ELECT 1-50V	AB.....
C	335	87-010-401-080	CAP,ELECT 1-50V	AB.....
C	354	87-010-175-080	CAP 560P	AB.....
C	358	87-010-183-080	C-CAP,S 2700P-50 B	AB.....
C	359	87-010-183-080	C-CAP,S 2700P-50 B	AB.....
C	357	87-010-197-080	CAP,CHIP 0.01 DM	AB.....
C	356	87-010-260-080	CAP,ELECT 47-25V	AB.....
C	351	87-012-140-080	CAP 470P	AB.....
C	352	87-012-140-080	CAP 470P	AB.....
C	355	87-012-349-080	C-CAP,S 1000P-50 CH	AB.....
C	360	87-010-183-080	C-CAP,S 2700P-50 B	AB.....
C	363	87-A10-772-080	CAP,M 5600P-50 J	AB.....
C	379	87-010-382-080	CAP,ELECT 22-25V	AB.....
C	373	87-016-083-080	C-CAP,S 0.15-16 RK	AB.....
C	374	87-016-083-080	C-CAP,S 0.15-16 RK	AB.....
C	380	87-010-382-080	CAP,ELECT 22-25V	AB.....
C	388	87-012-156-080	C-CAP,S 220P-50 CH	AB.....
C	391	87-010-319-080	C-CAP,S 56P-50 CH	AB.....
C	392	87-010-319-080	C-CAP,S 56P-50 CH	AB.....
C	393	87-010-319-080	C-CAP,S 56P-50 CH	AB.....
C	394	87-010-319-080	C-CAP,S 56P-50 CH	AB.....
CN	301	87-099-827-010	CONN,3P S2M-3W	AB.....
CN	351	87-099-832-010	CONN,8P S2M-8W	AB.....
D	352	87-A40-269-080	C-DIODE,MC2836	AB.....
IC	303	87-A20-783-040	C-IC,BA7762AFS	AB.....
L	301	87-A50-049-010	COIL,TRAP 85K(COI)	AB.....
L	302	87-A50-049-010	COIL,TRAP 85K(COI)	AB.....
L	351	87-007-342-010	COIL,OSC 85K BIAS	AB.....
Q	359	87-026-610-080	TR,KTC3198GR	AB.....
Q	358	87-026-610-080	TR,KTC3198GR	AB.....
Q	357	87-026-610-080	TR,KTC3198GR	AB.....
Q	354	87-A30-087-080	C-FET,2SK2158	AB.....
Q	351	87-A30-087-080	C-FET,2SK2158	AB.....
Q	353	87-A30-087-080	C-FET,2SK2158	AB.....
Q	355	87-A30-105-080	C-TR,RT1P 441C	AB.....
SFR	351	87-A90-433-080	SFR,50K H NVZ6TLTA	AB.....
SFR	352	87-A90-433-080	SFR,50K H NVZ6TLTA	AB.....
C	457	87-010-196-080	CHIP CAPACITOR,0.1-25	A.....
C	458	87-010-196-080	CHIP CAPACITOR,0.1-25	A.....
C	451	87-010-401-080	CAP,ELECT 1-50V	AB.....
C	452	87-010-401-080	CAP,ELECT 1-50V	AB.....
C	459	87-A11-004-080	CAP,M 0.022-50 J DE	A.....
C	467	87-010-805-080	CAP,S 1-16	AB.....
C	466	87-A11-004-080	CAP,M 0.022-50 J DE	A.....
C	460	87-A11-004-080	CAP,M 0.022-50 J DE	A.....
C	465	87-A11-004-080	CAP,M 0.022-50 J DE	A.....
IC	451	87-A21-031-040	C-IC,BU4551BF	A.....
C	9	87-010-917-090	CAP,E 3300-50 M SMG	AB.....
C	5	87-012-368-080	C-CAP,S 0.1-50 F	AB.....
C	3	87-012-368-080	C-CAP,S 0.1-50 F	AB.....
C	6	87-012-368-080	C-CAP,S 0.1-50 F	AB.....
C	4	87-012-368-080	C-CAP,S 0.1-50 F	AB.....
C	1	87-012-369-080	C-CAP,S 0.047-50F	AB.....
C	2	87-012-369-080	C-CAP,S 0.047-50F	AB.....

ELECTRICAL PARTS LIST-3/7

C	10	87-010-917-090	CAP,E 3300-50 M SMG	AB.....
C	23	87-010-247-080	CAP, ELECT 100-50V	AB.....
C	24	87-010-247-080	CAP, ELECT 100-50V	AB.....
C	29	87-010-247-080	CAP, ELECT 100-50V	AB.....
C	28	87-010-263-080	CAP, ELECT 100-10V	AB.....
C	22	87-010-385-080	CAP, ELECT 220-25V	AB.....
C	21	87-010-385-080	CAP, ELECT 220-25V	AB.....
C	25	87-010-430-080	CAP, ELECT 100-63	AB.....
C	27	87-012-140-080	CAP 470P	AB.....
C	30	87-010-112-080	CAP, ELECT 100-16V	AB.....
C	31	87-010-235-080	CAP,E 470-16 SME	AB.....
C	34	87-010-405-080	CAP, ELECT 10-50V	AB.....
C	33	87-010-405-080	CAP, ELECT 10-50V	AB.....
C	61	87-010-260-080	CAP, ELECT 47-25V	AB.....
C	62	87-010-403-080	CAP, ELECT 3.3-50V	AB.....
C	92	87-010-248-080	CAP, ELECT 220-10V	A.....
C	93	87-010-380-080	CAP, ELECT 47-16V	AB.....
C	91	87-010-401-080	CAP, ELECT 1-50V	AB.....
CN	1	87-A60-739-010	CONN,13P JL-BT	A.....
CN	91	87-A60-109-010	CONN,2P V S2M-2W	AB.....
CNA	1	8Z-NF8-669-010	CONN ASSY,9P VH	AB.....
D	1	87-017-654-060	DIODE,GBU6J	AB.....
D	8	87-020-465-080	DIODE,1SS133 (110MA)	AB.....
D	9	87-020-465-080	DIODE,1SS133 (110MA)	AB.....
D	5	87-070-274-080	DIODE,1N4003 SEM	AB.....
D	6	87-070-274-080	DIODE,1N4003 SEM	AB.....
D	3	87-070-274-080	DIODE,1N4003 SEM	AB.....
D	4	87-070-274-080	DIODE,1N4003 SEM	AB.....
D	7	87-A40-383-080	ZENER,MTZJ30A	AB.....
D	10	87-A40-345-080	ZENER,MTZJ10C	AB.....
D	64	87-070-274-080	DIODE,1N4003 SEM	AB.....
D	62	87-A40-269-080	C-DIODE,MC2836	AB.....
D	61	87-A40-270-080	C-DIODE,MC2838	AB.....
D	91	87-020-465-080	DIODE,1SS133 (110MA)	AB.....
D	92	87-020-465-080	DIODE,1SS133 (110MA)	AB.....
JW	16	87-008-372-080	FILTER, EMI BL OIRNI	.B.....
Q	1	87-026-609-080	TR,KTA1266GR	AB.....
Q	2	87-026-609-080	TR,KTA1266GR	AB.....
Q	5	87-026-610-080	TR,KTC3198GR	AB.....
Q	7	87-A30-075-080	C-TR,2SA1235F	AB.....
Q	9	87-A30-196-080	TR,2SC4115SRS	AB.....
Q	3	89-213-702-010	TR,2SB1370 (1.8W)	.B.....
Q	61	87-A30-074-080	C-TR,RT1P 141C	.B.....
Q	66	87-A30-075-080	C-TR,2SA1235F	AB.....
Q	64	87-A30-075-080	C-TR,2SA1235F	AB.....
Q	92	87-026-609-080	TR,KTA1266GR	AB.....
Q	91	87-A30-076-080	C-TR,2SC3052F	AB.....
R	20	87-A00-261-080	RES,M/F 0.56-1W J	A.....
WH	1	87-A90-510-010	HLDR,WIRE 2.5-9P	AB.....
		87-067-703-010	TAPPING SCREW, BVT2+3-10	.B.....
C	101	87-010-178-080	CHIP CAP 1000P	AB.....
C	102	87-010-178-080	CHIP CAP 1000P	AB.....
C	102	87-010-182-080	C-CAP,S 2200P-50 B	.B.....
C	101	87-010-182-080	C-CAP,S 2200P-50 B	.B.....
C	105	87-010-186-080	CAP,CHIP 4700P	.B.....
C	106	87-010-186-080	CAP,CHIP 4700P	.B.....
C	109	87-010-322-080	C-CAP,S 100P-50 CH	.B.....
C	108	87-010-404-080	CAP, ELECT 4.7-50V	.B.....
C	107	87-010-404-080	CAP, ELECT 4.7-50V	.B.....
C	112	87-010-260-080	CAP, ELECT 47-25V	.B.....
C	111	87-010-260-080	CAP, ELECT 47-25V	.B.....
C	110	87-010-322-080	C-CAP,S 100P-50 CH	.B.....
C	118	87-016-247-080	C-CAP,0.1-50 F	.B.....
C	117	87-016-247-080	C-CAP,0.1-50 F	.B.....
C	113	87-A10-812-080	C-CAP,S 220P-200 J CH	.B.....
C	114	87-A10-812-080	C-CAP,S 220P-200 J CH	.B.....
C	123	87-010-176-080	C-CAP,S 680P-50 SL	AB.....
C	124	87-010-176-080	C-CAP,S 680P-50 SL	AB.....
C	129	87-010-191-080	C-CAP,S 0.015-50 F	AB.....
C	130	87-010-191-080	C-CAP,S 0.015-50 F	AB.....
C	133	87-010-197-080	CAP, CHIP 0.01 DM	AB.....
C	136	87-012-368-080	C-CAP,S 0.1-50 F	AB.....
D	109	87-020-465-080	DIODE,1SS133 (110MA)	.B.....
D	108	87-A40-488-080	DIODE,1SS244	.B.....
D	107	87-A40-488-080	DIODE,1SS244	.B.....
D	110	87-020-465-080	DIODE,1SS133 (110MA)	.B.....
D	111	87-A40-270-080	C-DIODE,MC2838	.B.....
J	203	87-A60-238-010	TERMINAL,SP 4P (MSC)	AB.....
J	201	87-A60-483-010	JACK,DIA6.3 BLK ST W/S KM	AB.....
L	101	87-003-383-010	COIL,1UH-S	AB.....
L	102	87-003-383-010	COIL,1UH-S	AB.....
Q	106	87-A30-075-080	C-TR,2SA1235F	AB.....
Q	104	87-A30-075-080	C-TR,2SA1235F	AB.....
Q	103	87-A30-075-080	C-TR,2SA1235F	AB.....
Q	105	87-A30-075-080	C-TR,2SA1235F	AB.....
Q	107	87-A30-076-080	C-TR,2SC3052F	.B.....
Q	108	87-A30-076-080	C-TR,2SC3052F	.B.....
Q	109	87-A30-076-080	C-TR,2SC3052F	.B.....
Q	101	87-A30-257-080	C-TR,2SD1306E	AB.....
Q	102	87-A30-257-080	C-TR,2SD1306E	AB.....
Q	110	87-A30-076-080	C-TR,2SC3052F	.B.....
Q	115	87-A30-097-010	TR, FN 1016	.B.....

ELECTRICAL PARTS LIST-4/7

Q	116	87-A30-097-010	TR, FN 1016	.B.....
Q	117	87-A30-098-010	TR, FP 1016	.B.....
Q	118	87-A30-098-010	TR, FP 1016	.B.....
Q	111	87-A30-190-080	TR, CC5551	.B.....
Q	112	87-A30-190-080	TR, CC5551	.B.....
Q	126	87-A30-075-080	C-TR, 2SA1235F	AB.....
Q	129	87-A30-076-080	C-TR, 2SC3052F	.B.....
Q	128	87-A30-076-080	C-TR, 2SC3052F	.B.....
Q	124	87-A30-106-070	C-TR, CMBT5551	.B.....
Q	123	87-A30-106-070	C-TR, CMBT5551	.B.....
Q	130	87-A30-076-080	C-TR, 2SC3052F	.B.....
Q	131	87-A30-076-080	C-TR, 2SC3052F	.B.....
R	129	87-A00-257-080	RES, M/F 0.15-1W J	.B.....
R	130	87-A00-257-080	RES, M/F 0.15-1W J	.B.....
R	131	87-A00-257-080	RES, M/F 0.15-1W J	.B.....
R	132	87-A00-257-080	RES, M/F 0.15-1W J	.B.....
R	146	87-A00-439-050	RES, 180-1/2W J RP	A.....
R	145	87-A00-439-050	RES, 180-1/2W J RP	A.....
R	144	87-A00-439-050	RES, 180-1/2W J RP	A.....
R	143	87-A00-439-050	RES, 180-1/2W J RP	A.....
R	144	87-A00-440-050	RES, 220-1/2W J RP	.B.....
R	146	87-A00-440-050	RES, 220-1/2W J RP	.B.....
R	143	87-A00-440-050	RES, 220-1/2W J RP	.B.....
R	145	87-A00-440-050	RES, 220-1/2W J RP	.B.....
R	165	87-A00-257-080	RES, M/F 0.15-1W J	.B.....
R	166	87-A00-257-080	RES, M/F 0.15-1W J	.B.....
TH	101	87-A91-042-080	C-THMS, 100K 55001	.B.....
TH	102	87-A91-042-080	C-THMS, 100K 55001	.B.....
C	203	87-010-177-080	C-CAP, S 820P-50 SL	A.....
C	204	87-010-177-080	C-CAP, S 820P-50 SL	A.....
C	209	87-010-404-080	CAP, ELECT 4.7-50V	.B.....
C	212	87-010-182-080	C-CAP, S 2200P-50 B	.B.....
C	211	87-010-182-080	C-CAP, S 2200P-50 B	.B.....
C	217	87-010-260-080	CAP, ELECT 47-25V	.B.....
C	218	87-010-260-080	CAP, ELECT 47-25V	.B.....
C	210	87-010-404-080	CAP, ELECT 4.7-50V	.B.....
C	213	87-010-408-080	CAP, ELECT 47-50V	.B.....
C	214	87-010-408-080	CAP, ELECT 47-50V	.B.....
C	219	87-A10-946-080	C-CAP, S 220P-100 J CH	.B.....
C	228	87-010-186-080	CAP, CHIP 4700P	.B.....
C	227	87-010-186-080	CAP, CHIP 4700P	.B.....
C	226	87-010-544-080	CAP, ELECT 0.1-50V	.B.....
C	225	87-010-544-080	CAP, ELECT 0.1-50V	.B.....
C	220	87-A10-946-080	C-CAP, S 220P-100 J CH	.B.....
C	234	87-010-190-080	S CHIP F 0.01	AB.....
C	232	87-010-196-080	CHIP CAPACITOR, 0.1-25	AB.....
C	238	87-010-322-080	C-CAP, S 100P-50 CH	AB.....
C	230	87-010-993-080	C-CAP, S 0.056-25 B	AB.....
C	252	87-010-183-080	C-CAP, S 2700P-50 B	AB.....
C	251	87-010-402-080	CAP, ELECT 2.2-50V	AB.....
C	899	87-010-196-080	CHIP CAPACITOR, 0.1-25	AB.....
C	898	87-010-993-080	C-CAP, S 0.056-25 B	AB.....
C	900	87-010-196-080	CHIP CAPACITOR, 0.1-25	AB.....
CN	201	87-A60-739-010	CONN, 13P JL-BT	A.....
D	208	87-A40-488-080	DIODE, 1SS244	.B.....
D	207	87-A40-488-080	DIODE, 1SS244	.B.....
D	213	87-020-465-080	DIODE, 1SS133 (110MA)	.B.....
D	211	87-A40-270-080	C-DIODE, MC2838	.B.....
J	205	87-A60-751-010	JACK, PIN 2P R/W BLUE	A.....
J	204	87-A60-752-010	JACK, PIN 4P R/W, O/B	.B.....
J	206	87-A60-872-010	JACK, PIN 3P W/R/O	A.....
L	202	87-003-383-010	COIL, 1UH-S	AB.....
L	801	87-003-383-010	COIL, 1UH-S	AB.....
Q	204	87-A30-075-080	C-TR, 2SA1235F	.B.....
Q	206	87-A30-075-080	C-TR, 2SA1235F	.B.....
Q	205	87-A30-075-080	C-TR, 2SA1235F	.B.....
Q	203	87-A30-075-080	C-TR, 2SA1235F	.B.....
Q	209	87-A30-076-080	C-TR, 2SC3052F	.B.....
Q	208	87-A30-076-080	C-TR, 2SC3052F	.B.....
Q	207	87-A30-076-080	C-TR, 2SC3052F	.B.....
Q	210	87-A30-076-080	C-TR, 2SC3052F	.B.....
Q	219	87-A30-119-040	C-TR, 2SC3906K R	.B.....
Q	212	87-A30-190-080	TR, CC5551	.B.....
Q	211	87-A30-190-080	TR, CC5551	.B.....
Q	218	87-A30-255-010	TR, 2SB1342	.B.....
Q	217	87-A30-255-010	TR, 2SB1342	.B.....
Q	216	87-A30-256-010	TR, 2SD1933	.B.....
Q	215	87-A30-256-010	TR, 2SD1933	.B.....
Q	225	87-A30-076-080	C-TR, 2SC3052F	.B.....
Q	227	87-A30-076-080	C-TR, 2SC3052F	.B.....
Q	226	87-A30-076-080	C-TR, 2SC3052F	.B.....
Q	224	87-A30-076-080	C-TR, 2SC3052F	.B.....
Q	223	87-A30-105-080	C-TR, RT1P 441C	AB.....
Q	220	87-A30-119-040	C-TR, 2SC3906K R	.B.....
Q	230	87-A30-257-080	C-TR, 2SD1306E	AB.....
R	233	87-A00-258-080	RES, M/F 0.22-1W J	.B.....
R	231	87-A00-258-080	RES, M/F 0.22-1W J	.B.....
R	232	87-A00-258-080	RES, M/F 0.22-1W J	.B.....
R	234	87-A00-258-080	RES, M/F 0.22-1W J	.B.....
R	266	87-A00-258-080	RES, M/F 0.22-1W J	.B.....
R	265	87-A00-258-080	RES, M/F 0.22-1W J	.B.....
C	801	87-010-176-080	C-CAP, S 680P-50 SL	AB.....

ELECTRICAL PARTS LIST-5/7

C	802	87-010-176-080	C-CAP,S 680P-50 SL	AB.....
C	808	87-010-401-080	CAP, ELECT 1-50V	AB.....
C	807	87-010-401-080	CAP, ELECT 1-50V	AB.....
C	806	87-010-958-080	CHIP -CAP,S 0.01-25BJ	AB.....
C	803	87-010-958-080	CHIP -CAP,S 0.01-25BJ	AB.....
C	804	87-010-958-080	CHIP -CAP,S 0.01-25BJ	AB.....
C	805	87-010-958-080	CHIP -CAP,S 0.01-25BJ	AB.....
C	810	87-010-112-080	CAP, ELECT 100-16V	AB.....
C	817	87-010-221-080	CAP, ELECT 470-10V	AB.....
C	813	87-010-400-080	CAP, ELECT 0.47-50V	AB.....
C	812	87-010-493-080	CAP,E 0.47-50 GAS	AB.....
C	811	87-010-493-080	CAP,E 0.47-50 GAS	AB.....
C	814	87-010-494-080	CAP ELECT GAS 1/50	AB.....
C	819	87-A10-800-080	C-CAP,S 6800P-16 J B CM	AB.....
C	818	87-A10-891-080	CAP,E 4.7-25 SME(K)	AB.....
C	824	87-010-374-080	CAP, ELECT 47-10V	AB.....
C	820	87-010-374-080	CAP, ELECT 47-10V	AB.....
C	829	87-010-545-080	CAP, ELECT 0.22-50V	AB.....
C	822	87-A10-804-080	C-CAP,S 0.1-25 J B	AB.....
C	839	87-010-805-080	CAP, S 1-16	AB.....
C	831	87-010-971-080	C-CAP,S 4700P-50 B J	AB.....
C	837	87-010-971-080	C-CAP,S 4700P-50 B J	AB.....
C	830	87-012-142-080	CAP, S 0.33-16	AB.....
C	838	87-012-349-080	C-CAP,S 1000P-50 CH	AB.....
C	832	87-012-349-080	C-CAP,S 1000P-50 CH	AB.....
C	835	87-A11-182-080	C-CAP,S 0.27-16 J B	AB.....
C	834	87-A11-182-080	C-CAP,S 0.27-16 J B	AB.....
C	836	87-A11-183-080	C-CAP,S 0.12-16 J B	AB.....
C	833	87-A11-183-080	C-CAP,S 0.12-16 J B	AB.....
C	840	87-010-401-080	CAP, ELECT 1-50V	AB.....
C	846	87-010-404-080	CAP, ELECT 4.7-50V	AB.....
C	847	87-010-404-080	CAP, ELECT 4.7-50V	AB.....
C	848	87-012-393-080	C-CAP,S 0.22-16 R K	AB.....
C	849	87-012-393-080	C-CAP,S 0.22-16 R K	AB.....
C	844	87-012-393-080	C-CAP,S 0.22-16 R K	AB.....
C	845	87-012-393-080	C-CAP,S 0.22-16 R K	AB.....
C	843	87-A10-229-080	C-CAP,S 0.68-10 K W5	AB.....
C	841	87-A10-799-080	C-CAP,S 5600P-16 J B CM	AB.....
C	842	87-A10-802-080	C-CAP,S 0.047-16 J B CM	AB.....
C	850	87-016-081-080	C-CAP,S 0.1-16 RK	AB.....
C	853	87-016-081-080	C-CAP,S 0.1-16 RK	AB.....
C	857	87-016-081-080	C-CAP,S 0.1-16 RK	AB.....
C	854	87-016-081-080	C-CAP,S 0.1-16 RK	AB.....
C	856	87-A10-801-080	C-CAP,S 0.022-16 J B CM	AB.....
C	855	87-A10-801-080	C-CAP,S 0.022-16 J B CM	AB.....
C	851	87-A10-802-080	C-CAP,S 0.047-16 J B CM	AB.....
C	852	87-A10-802-080	C-CAP,S 0.047-16 J B CM	AB.....
C	899	87-010-196-080	CHIP CAPACITOR,0.1-25	AB.....
C	898	87-010-993-080	C-CAP,S 0.056-25 B	.B.....
D	802	87-070-136-080	ZENER,MTZJ5.1B	AB.....
D	801	87-A40-442-080	ZENER,MTZJ9.1A	AB.....
IC	801	87-A20-853-010	C-IC,M62463FP	AB.....
L	801	87-003-383-010	COIL,1UH-S	.B.....
R	807	87-022-214-080	C-RES S100K-1/10WF	AB.....
C	601	87-010-180-080	C-CER 1500P	AB.....
C	602	87-010-180-080	C-CER 1500P	AB.....
C	606	87-010-318-080	C-CAP,S 47P-50 CH	AB.....
C	605	87-010-318-080	C-CAP,S 47P-50 CH	AB.....
C	619	87-010-185-080	C-CAP,S 3900P-50 B	AB.....
C	613	87-016-081-080	C-CAP,S 0.1-16 RK	AB.....
C	614	87-016-081-080	C-CAP,S 0.1-16 RK	AB.....
C	617	87-A11-008-080	CAP,M 0.056-50 J DE	AB.....
C	618	87-A11-008-080	CAP,M 0.056-50 J DE	AB.....
C	616	87-A11-011-080	CAP,M 0.12-50 J DE	AB.....
C	615	87-A11-011-080	CAP,M 0.12-50 J DE	AB.....
C	620	87-010-185-080	C-CAP,S 3900P-50 B	AB.....
C	627	87-010-196-080	CHIP CAPACITOR,0.1-25	AB.....
C	622	87-010-401-080	CAP, ELECT 1-50V	AB.....
C	621	87-010-401-080	CAP, ELECT 1-50V	AB.....
C	629	87-010-405-080	CAP, ELECT 10-50V	AB.....
C	624	87-A10-773-080	CAP,M 0.10-50 J	AB.....
C	623	87-A10-773-080	CAP,M 0.10-50 J	AB.....
C	637	87-010-183-080	C-CAP,S 2700P-50 B	AB.....
C	636	87-010-194-080	CAP, CHIP 0.047	AB.....
C	635	87-010-196-080	CHIP CAPACITOR,0.1-25	AB.....
C	634	87-010-196-080	CHIP CAPACITOR,0.1-25	AB.....
C	630	87-010-213-080	C-CAP,S 0.015-50 B	AB.....
C	633	87-010-263-080	CAP, ELECT 100-10V	AB.....
C	632	87-010-263-080	CAP, ELECT 100-10V	AB.....
C	638	87-010-314-080	C-CAP,S 22P-50V	AB.....
C	639	87-010-314-080	C-CAP,S 22P-50V	AB.....
C	631	87-010-992-080	C-CAP,S 0.047-25 B	AB.....
C	641	87-010-196-080	CHIP CAPACITOR,0.1-25	AB.....
CN	604	87-099-570-010	CONN,13P TUC-P13P-B1	AB.....
CN	601	87-099-719-010	CONN,30P TYK-B(X)	AB.....
CN	602	87-A60-131-010	CONN,6P V FE	AB.....
CN	605	87-A60-189-010	CONN,16P V TUC-P16P-B1	AB.....
D	601	87-A40-002-080	ZENER,MTZJ5.1C	AB.....
D	602	87-A40-438-080	ZENER,MTZJ4.7A	AB.....
IC	601	87-A21-011-040	C-IC,M62445FP-600D	AB.....
J	602	87-A60-398-010	JACK,PIN 2P R/W HSP-242V24	AB.....
JW	604	87-020-465-080	DIODE,1SS133 (110MA)	A.....

ELECTRICAL PARTS LIST-6/7

O	601	87-026-609-080	TR,KTA1266GR	AB.....
C	736	87-010-193-080	CHIP CAPACITOR,0.033	AB.....
C	732	87-010-196-080	CHIP CAPACITOR,0.1-25	AB.....
C	733	87-010-196-080	CHIP CAPACITOR,0.1-25	AB.....
C	731	87-010-560-080	CAP,E 10-50 GAS	AB.....
C	734	87-012-157-080	C-CAP,S 330P-50 CH	AB.....
C	834	87-A11-182-080	C-CAP,S 0.27-16 J B	A.....
C	835	87-A11-182-080	C-CAP,S 0.27-16 J B	A.....
C	836	87-A11-183-080	C-CAP,S 0.12-16 J B	A.....
C	833	87-A11-183-080	C-CAP,S 0.12-16 J B	A.....
Q	732	87-A30-075-080	C-TR,2SA1235F	AB.....
Q	731	87-A30-076-080	C-TR,2SC3052F	AB.....
C	900	87-010-196-080	CHIP CAPACITOR,0.1-25	.B.....
C	102	87-010-405-080	CAP, ELECT 10-50V	A.....
C	101	87-010-405-080	CAP, ELECT 10-50V	A.....
C	199	87-010-197-080	CAP, CHIP 0.01 DM	A.....
C	204	87-010-405-080	CAP, ELECT 10-50V	A.....
C	203	87-010-405-080	CAP, ELECT 10-50V	A.....
C	208	87-010-408-080	CAP, ELECT 47-50V	A.....
C	207	87-010-408-080	CAP, ELECT 47-50V	A.....
C	212	87-010-260-080	CAP, ELECT 47-25V	A.....
C	211	87-010-260-080	CAP, ELECT 47-25V	A.....
C	219	87-016-247-080	C-CAP,0.1-50 F	A.....
C	214	87-A10-812-080	C-CAP,S 220P-200 J CH	A.....
C	213	87-A10-812-080	C-CAP,S 220P-200 J CH	A.....
C	221	87-010-178-080	CHIP CAP 1000P	A.....
C	222	87-010-178-080	CHIP CAP 1000P	A.....
C	220	87-016-247-080	C-CAP,0.1-50 F	A.....
C	309	87-010-322-080	C-CAP,S 100P-50 CH	A.....
C	308	87-010-403-080	CAP, ELECT 3.3-50V	A.....
C	307	87-010-403-080	CAP, ELECT 3.3-50V	A.....
C	303	87-010-404-080	CAP, ELECT 4.7-50V	A.....
C	304	87-010-404-080	CAP, ELECT 4.7-50V	A.....
C	313	87-010-260-080	CAP, ELECT 47-25V	A.....
C	314	87-010-260-080	CAP, ELECT 47-25V	A.....
C	310	87-010-322-080	C-CAP,S 100P-50 CH	A.....
C	319	87-012-368-080	C-CAP,S 0.1-50 F	A.....
C	311	87-A10-946-080	C-CAP,S 220P-100 J CH	A.....
C	312	87-A10-946-080	C-CAP,S 220P-100 J CH	A.....
C	322	87-010-186-080	CAP,CHIP 4700P	A.....
C	321	87-010-186-080	CAP,CHIP 4700P	A.....
C	320	87-012-368-080	C-CAP,S 0.1-50 F	A.....
C	407	87-010-186-080	CAP,CHIP 4700P	A.....
C	404	87-010-260-080	CAP, ELECT 47-25V	A.....
C	401	87-010-322-080	C-CAP,S 100P-50 CH	A.....
C	403	87-010-403-080	CAP, ELECT 3.3-50V	A.....
C	400	87-010-404-080	CAP, ELECT 4.7-50V	A.....
C	408	87-010-544-080	CAP, ELECT 0.1-50V	A.....
C	405	87-A10-946-080	C-CAP,S 220P-100 J CH	A.....
C	501	87-010-183-080	C-CAP,S 2700P-50 B	A.....
C	509	87-010-186-080	CAP,CHIP 4700P	A.....
C	506	87-010-260-080	CAP, ELECT 47-25V	A.....
C	503	87-010-322-080	C-CAP,S 100P-50 CH	A.....
C	505	87-010-403-080	CAP, ELECT 3.3-50V	A.....
C	502	87-010-404-080	CAP, ELECT 4.7-50V	A.....
C	507	87-A10-946-080	C-CAP,S 220P-100 J CH	A.....
C	510	87-010-544-080	CAP, ELECT 0.1-50V	A.....
C	603	87-010-190-080	S CHIP F 0.01	A.....
C	601	87-010-993-080	C-CAP,S 0.056-25 B	A.....
C	602	87-012-368-080	C-CAP,S 0.1-50 F	A.....
CN	101	87-A60-727-010	CONN,13P JL-R	A.....
CN	102	87-A60-727-010	CONN,13P JL-R	A.....
CN	501	87-099-043-010	CONN 2P EH	A.....
CN	502	87-099-043-010	CONN 2P EH	A.....
D	197	87-A40-270-080	C-DIODE,MC2838	A.....
D	208	87-A40-488-080	DIODE,1SS244	A.....
D	207	87-A40-488-080	DIODE,1SS244	A.....
D	212	87-A40-270-080	C-DIODE,MC2838	A.....
D	309	87-A40-488-080	DIODE,1SS244	A.....
D	312	87-A40-270-080	C-DIODE,MC2838	A.....
D	310	87-A40-488-080	DIODE,1SS244	A.....
D	404	87-A40-488-080	DIODE,1SS244	A.....
D	412	87-A40-270-080	C-DIODE,MC2838	A.....
D	504	87-A40-488-080	DIODE,1SS244	A.....
JW	104	87-020-465-080	DIODE,1SS133 (110MA)	A.....
JW	103	87-020-465-080	DIODE,1SS133 (110MA)	A.....
L	601	87-003-383-010	COIL,1UH-S	A.....
Q	102	89-213-702-010	TR,2SB1370 (1.8W)	A.....
Q	101	89-213-702-010	TR,2SB1370 (1.8W)	A.....
Q	209	87-A30-190-080	TR,CC5551	A.....
Q	210	87-A30-190-080	TR,CC5551	A.....
Q	216	87-A30-214-010	TR,2SB1344	A.....
Q	215	87-A30-214-010	TR,2SB1344	A.....
Q	217	87-A30-215-010	TR,2SD2025	A.....
Q	218	87-A30-215-010	TR,2SD2025	A.....
Q	222	87-A30-106-070	C-TR,CMBT5551	A.....
Q	221	87-A30-106-070	C-TR,CMBT5551	A.....
Q	317	87-A30-106-070	C-TR,CMBT5551	A.....
Q	318	87-A30-106-070	C-TR,CMBT5551	A.....
Q	311	87-A30-190-080	TR,CC5551	A.....
Q	312	87-A30-190-080	TR,CC5551	A.....
Q	313	87-A30-255-010	TR,2SB1342	A.....

ELECTRICAL PARTS LIST-7/7

Q	314	87-A30-255-010	TR, 2SB1342	A.....
Q	316	87-A30-256-010	TR, 2SD1933	A.....
Q	315	87-A30-256-010	TR, 2SD1933	A.....
Q	403	87-A30-075-080	C-TR, 2SA1235F	A.....
Q	407	87-A30-190-080	TR, CC5551	A.....
Q	409	87-A30-255-010	TR, 2SB1342	A.....
Q	408	87-A30-256-010	TR, 2SD1933	A.....
Q	410	87-A30-119-040	C-TR, 2SC3906K R	A.....
Q	502	87-A30-075-080	C-TR, 2SA1235F	A.....
Q	504	87-A30-075-080	C-TR, 2SA1235F	A.....
Q	506	87-A30-076-080	C-TR, 2SC3052F	A.....
Q	503	87-A30-076-080	C-TR, 2SC3052F	A.....
Q	505	87-A30-076-080	C-TR, 2SC3052F	A.....
Q	507	87-A30-076-080	C-TR, 2SC3052F	A.....
Q	508	87-A30-190-080	TR, CC5551	A.....
Q	509	87-A30-256-010	TR, 2SD1933	A.....
Q	501	87-A30-257-080	C-TR, 2SD1306E	A.....
Q	511	87-A30-119-040	C-TR, 2SC3906K R	A.....
Q	510	87-A30-255-010	TR, 2SB1342	A.....
R	226	87-A00-257-080	RES, M/F 0.15-1W J	A.....
R	227	87-A00-257-080	RES, M/F 0.15-1W J	A.....
R	228	87-A00-257-080	RES, M/F 0.15-1W J	A.....
R	225	87-A00-257-080	RES, M/F 0.15-1W J	A.....
R	239	87-A00-257-080	RES, M/F 0.15-1W J	A.....
R	242	87-A00-257-080	RES, M/F 0.15-1W J	A.....
R	520	87-A00-258-080	RES, M/F 0.22-1W J	A.....
R	521	87-A00-258-080	RES, M/F 0.22-1W J	A.....

MECHANICAL PARTS LIST-1/1

NOTE: The characters in the suffix column indicate the part usage.

REF.NO	PARTS NO.	DESCRIPTION	SUFFIX
USTMXX	A.....
		KANRI	
		NO.	
82-NE6-067-010		BADGE,AIWA 30N	AB.....
86-NFZ-001-010		WINDOW, TOP	AB.....
8Z-NB8-011-110		PANEL, LEFT V-2	AB.....
8Z-NF8-003-010		BOX, CASS 1U	A.....
8Z-NF8-004-010		BOX, CASS 2U	A.....
8Z-NF8-021-010		WINDOW, CASS 1	AB.....
8Z-NF8-022-010		WINDOW, CASS 2	AB.....
8Z-NF8-024-010		WINDOW, CD	AB.....
8Z-NF8-025-010		PANEL, TRAY U	AB.....
8Z-NF8-037-010		BOX, CASS 1H	.B.....
8Z-NF8-038-010		BOX, CASS 2H	.B.....
8Z-NF9-042-010		PANEL, TOP V-2	AB.....
8Z-NF9-043-010		PANEL, RIGHT S V-2	AB.....
8Z-NFV-003-010		WINDOW, DISP U	A.....
8Z-NFV-004-010		WINDOW, DISP H	.B.....
8Z-NFV-006-010		CABI, FR U	A.....
8Z-NFV-013-010		CABI, FR LH	.B.....
8Z-NFV-021-010		CABI, REAR USTNM	A.....
8Z-NFV-022-010		CABI, REAR KSTE
8Z-NFV-023-010		CABI, REAR EZSTE
8Z-NFV-026-010		CABI, REAR LHSTM	.B.....
8Z-NF8-005-010		KEY, POWER	AB.....
8Z-NF8-006-010		KEY, CD	AB.....
8Z-NF8-007-010		REFLECTOR, ECO	AB.....
8Z-NF8-008-010		KEY, TIMER	AB.....
8Z-NF8-010-010		KEY, ASSY FUN	AB.....
8Z-NF8-013-010		KEY, ASSY PLAY	.B.....
8Z-NF8-016-010		KEY, ASSY PAUSE	AB.....
8Z-NF8-026-010		KNOB, RTRY JOG	AB.....
8Z-NF8-027-010		KNOB, RTRY VOL	AB.....
8Z-NF8-028-010		KNOB, RTRY MIC	AB.....
8Z-NF8-029-010		REFLECTOR, JOG	AB.....
8Z-NF8-030-010		KEY, ASSY PLAY U	A.....
8Z-NF8-050-010		KEY, KARAOKE	AB.....
8Z-NFV-001-010		KEY, PRO	.B.....
8Z-NFV-010-010		KEY, PRO U	A.....
81-532-080-010		LABEL, CASS. COMPT	AB.....
87-NF6-616-010		CONN ASSY, 8P RPB	.B.....
84-ZG1-245-210		CAP, OPTICAL	AB.....
82-NF5-218-010		SPR-T, EJECT 1 (SIN)	AB.....
82-NF5-219-010		SPR-T, EJECT 2 (SIN)	AB.....
82-NF5-229-010		PLATE, LOCK	AB.....
86-NF9-224-010		SPR-C, LOCK	AB.....
87-NF4-216-010		HLDR, LOCK 1	AB.....
87-NF4-217-010		HLDR, LOCK 2	AB.....
87-NF4-221-010		HLDR, CABLE	AB.....
87-NF8-220-010		DMPR, 150	AB.....
88-NF5-208-010		HLDR, PWB-M N	AB.....
8Z-NB8-240-010		COVER, PL	AB.....
8Z-NF8-205-010		HLDR, HT-SINK	.B.....
8Z-NF9-204-010		PLATE, MIC	AB.....
8Z-NFV-203-010		HLDR, HT F	A.....
8Z-NFV-204-010		HLDR, HT R	A.....
87-067-581-010		TAPPING SCREW, BVT2+3-15	.B.....
87-067-688-010		BVTT+3-6	AB.....
87-067-703-010		TAPPING SCREW, BVT2+3-10	AB.....
87-067-758-010		BVT2+3-12 W/O SLOT	.B.....
87-067-822-010		BVT2+3-20 W/O SLOT	A.....
87-078-191-010		S-SCREW, IT+4-10	AB.....
87-721-096-410		QT2+3-10 GLD	AB.....
87-721-097-410		QT2+3-12 GLD	AB.....
87-B10-091-010		UTT2+3-10 W/O BLK	AB.....
87-NF4-224-010		S-SCREW, IT3B+3-8 CU	AB.....
87-050-034-010		AC CORD ASSY, E
87-050-079-010		AC-CORD ASSY, E	.B.....
87-085-185-010		BUSHING, AC CORD (E)	.B.....
87-085-189-010		BUSHING, CORD (U)	A.....
87-099-811-010		PLUG, ADPTR CONV(K)
87-A80-110-010		AC CORD ASSY, U SPT-2W	A.....
87-A90-796-010		FAN, F614R-12MC-15-300MM	AB.....
88-906-251-110		FF-CABLE, 6P 1.25	AB.....
88-911-101-110		FF-CABLE, 11P 1.25	A.....
88-913-301-110		FF-CABLE, 13P-1.25	AB.....
88-915-101-110		FF-CABLE, 15P 1.25 100MM	.B.....
8Z-NFV-604-010		PT, ZNF-28 U	A.....
8Z-NFV-606-010		PT, ZNF-28 EZ
8Z-NFV-607-010		PT, ZNF-28 LH	.B.....
C 705 87-012-349-080		C-CAP, S 1000P-50 CH	AB.....
8Z-NF8-661-010		PT, SUB ZNF-8(U)	A.....
8Z-NF8-662-010		PT, SUB ZNF-8(E)
8Z-NF8-663-010		PT, SUB ZNF-8(H)	.B.....
88-NF8-205-010		GUIDE, FL	AB.....
WH 1 87-A90-510-010		HLDR, WIRE 2.5-9P	AB.....
87-067-703-010		TAPPING SCREW, BVT2+3-10	.B.....

ACCESSORIES / PACKAGE LIST-1/1

NOTE: The characters in the suffix column indicate the part usage.

REF.NO	PARTS NO.	NO.	DESCRIPTION	SUFFIX
USTM		XX		A
		KANRI		
	8Z-NFV-902-010		IB,LH(ESP)M	.B
	8Z-NFV-903-010		IB,U(ESF)M	A
	8Z-NFV-905-010		IB,K(E)E	
	8Z-NFV-906-010		IB,EZ(9L)E	
	87-006-225-010		AM LOOP ANT NC2	AB
	87-043-106-010		WIRE, FM ANT (Z)	
	87-043-115-010		ANT,FEEDER FM	AB
	87-099-789-010		PLUG,ADPTR IR44	.B
	8Z-NFV-702-010		RC UNIT,RC-ZAS05	AB

SCHEMATIC DIAGRAM - 1 (MAIN)

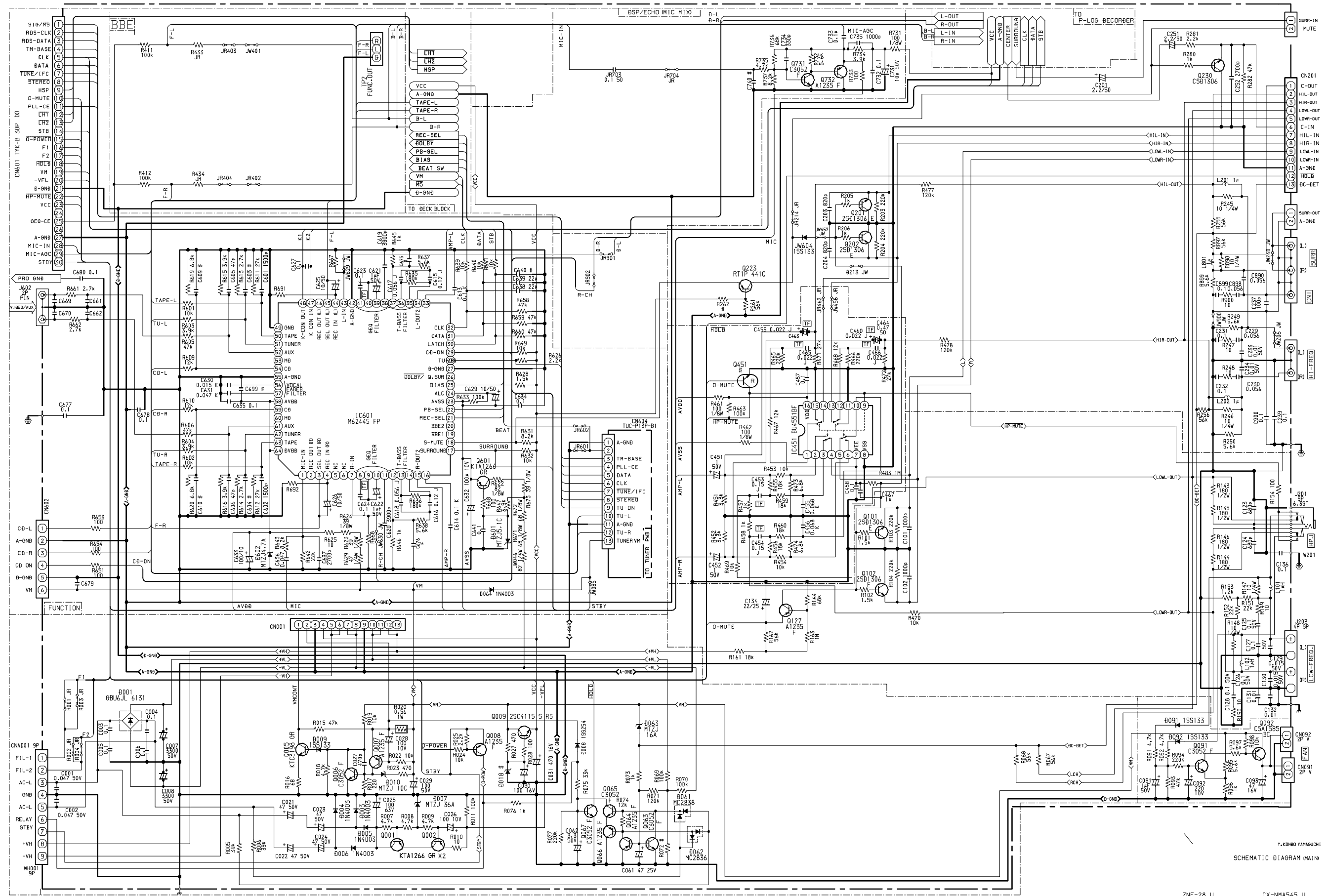

B-ZNF-28MAIN (P1)

ZNF-28 U CX-NMA545 U
27 NOV 1998

SCHEMATIC DIAGRAM - 2 (MAIN-DECK)

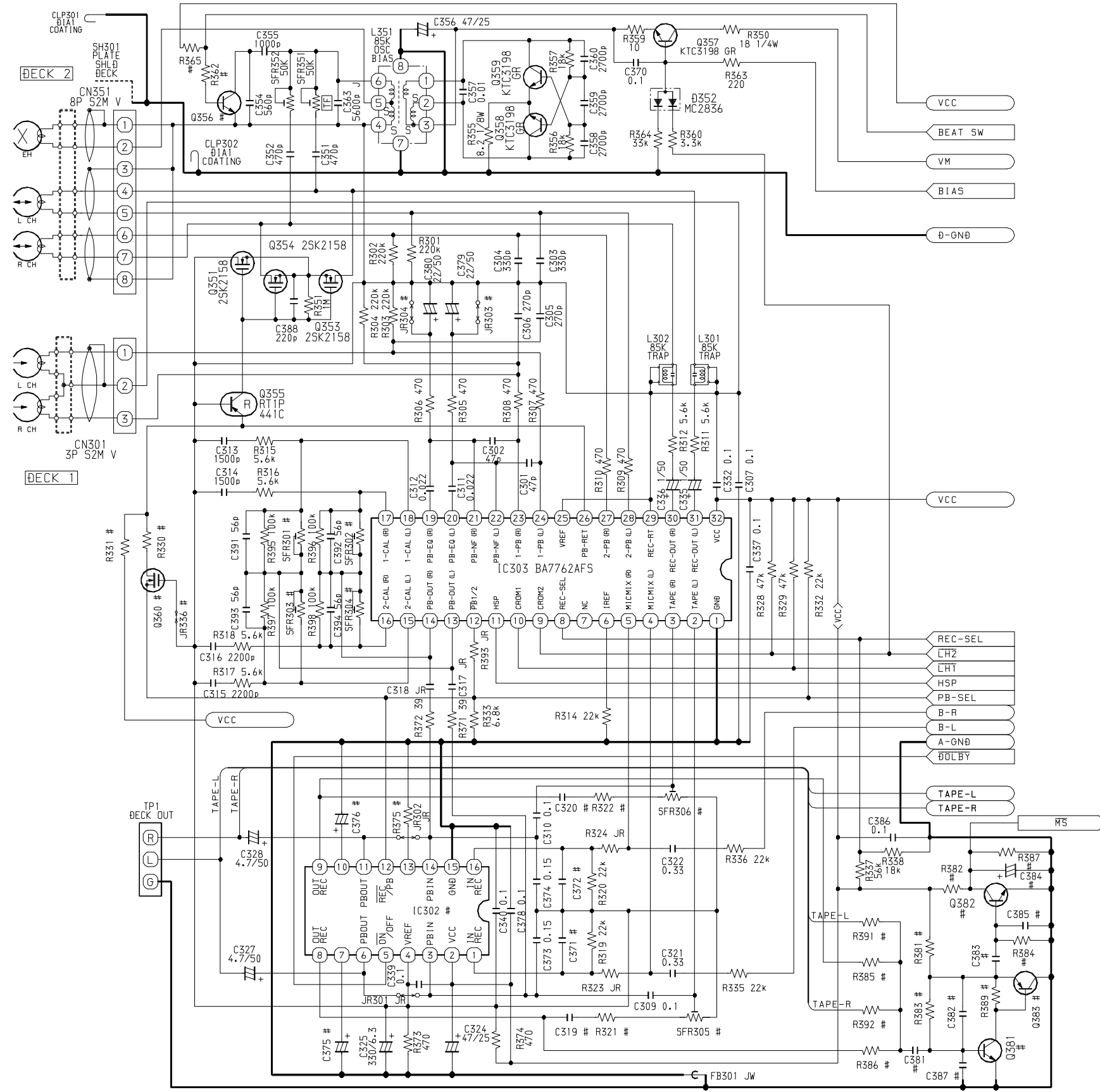

T-ZNF-MAIN-ALL (P2)

SCHEMATIC DIAGRAM (DECK)

SCHEMATIC DIAGRAM - 3 (MAIN-PROLOGIC)

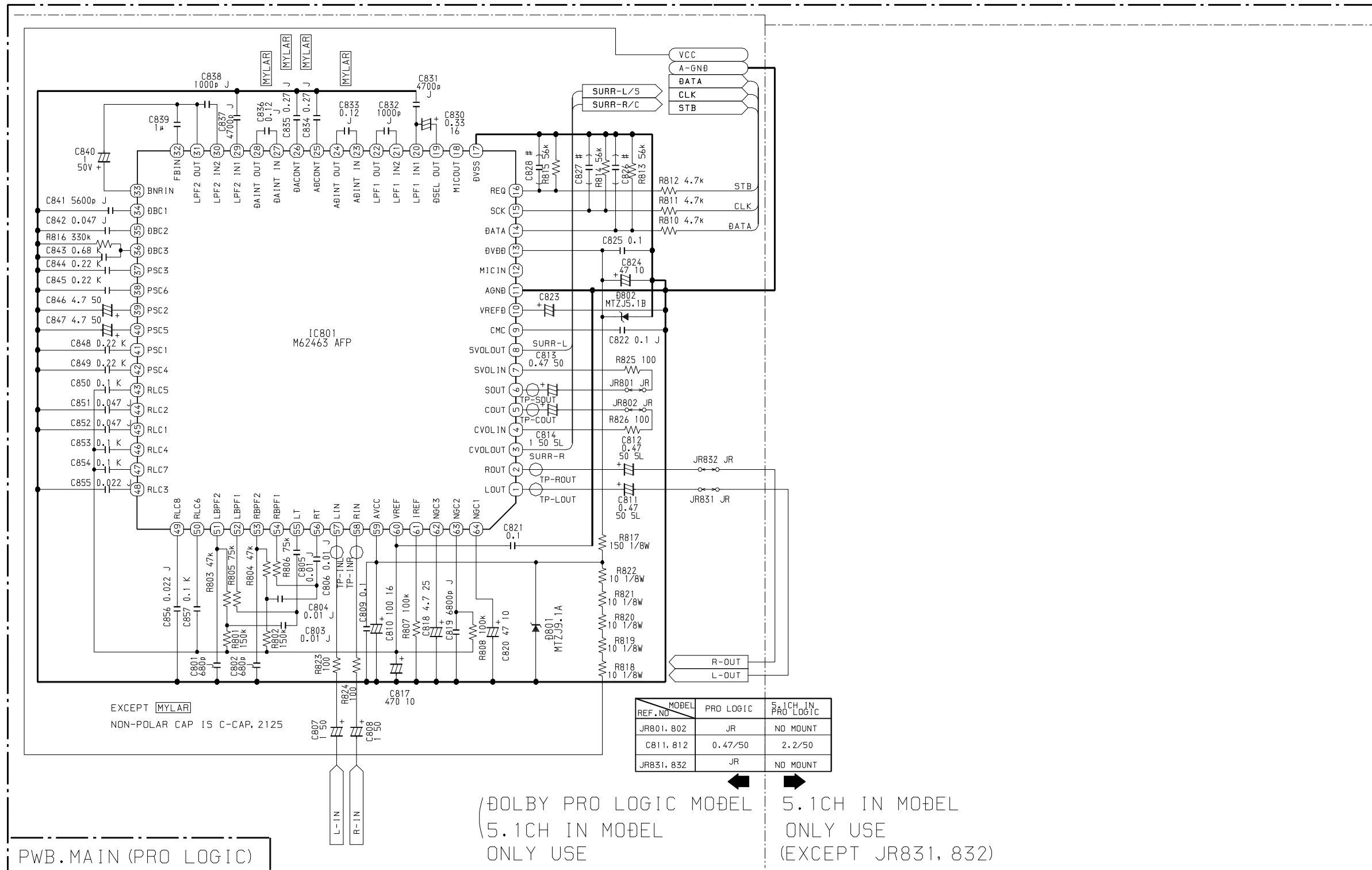

Y.KONDO
(PRO LOGIC)
SCHEMATIC DIAGRAM

SCHEMATIC DIAGRAM - 4 (AMP)

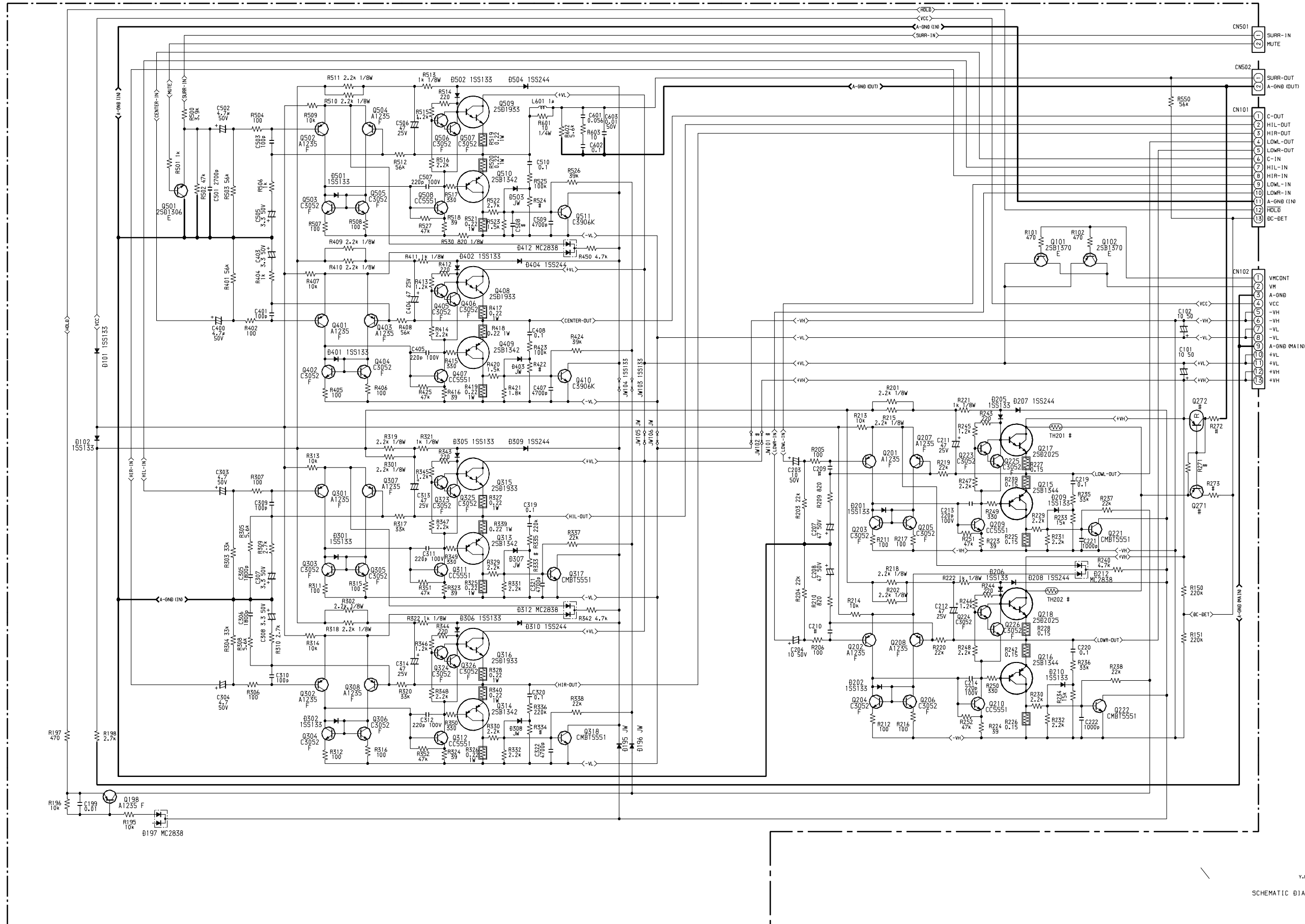

Y.KONDO
SCHEMATIC DIAGRAM (AMP)

B-ZNF-28PRD

ZNF-28 U

CX-NMA545 U
27 NOV 1998

SCHEMATIC DIAGRAM - 5 (FRONT)

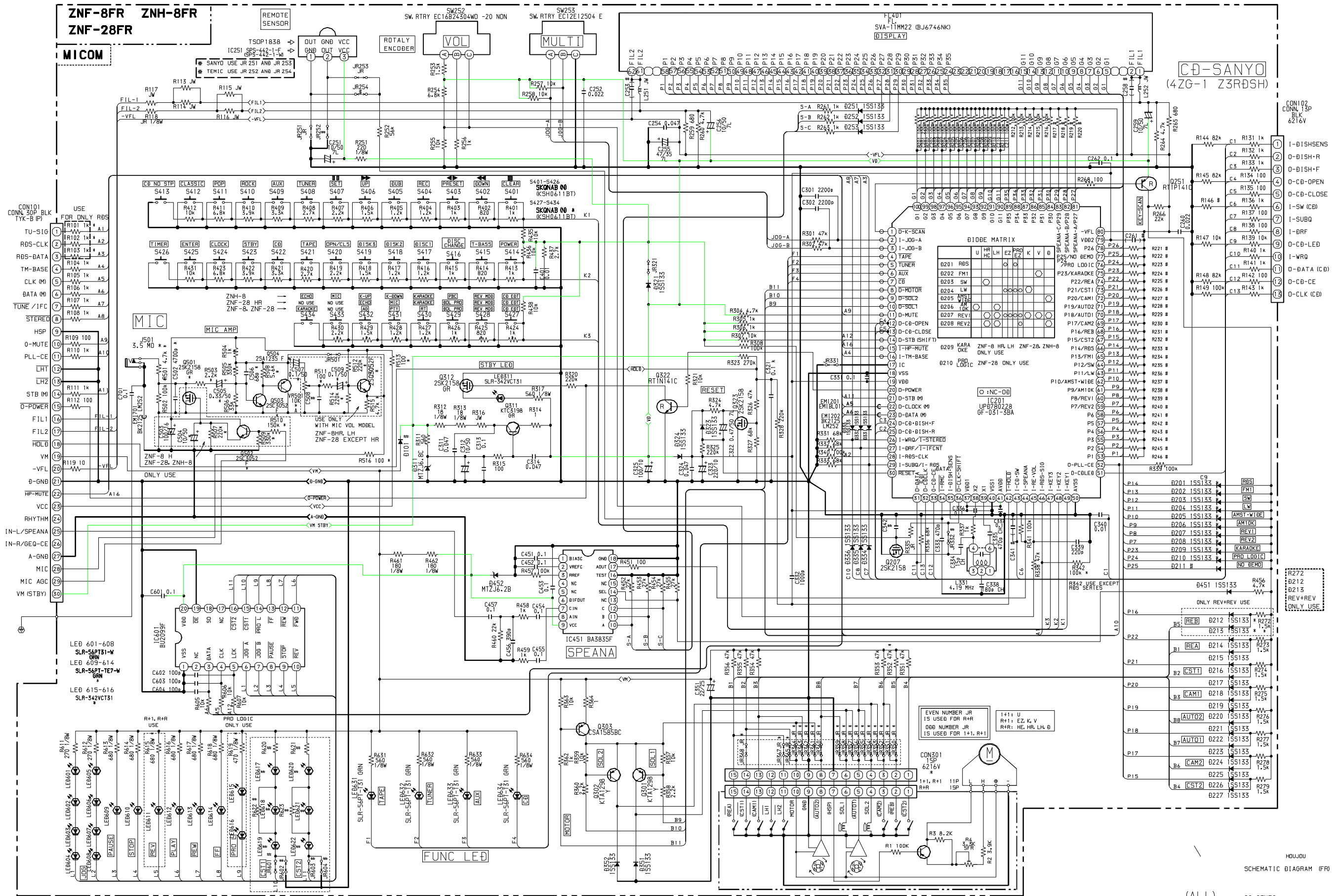

(ALL) QC-82NF8- ZNF-8

SCHEMATIC DIAGRAM - 6(PS)

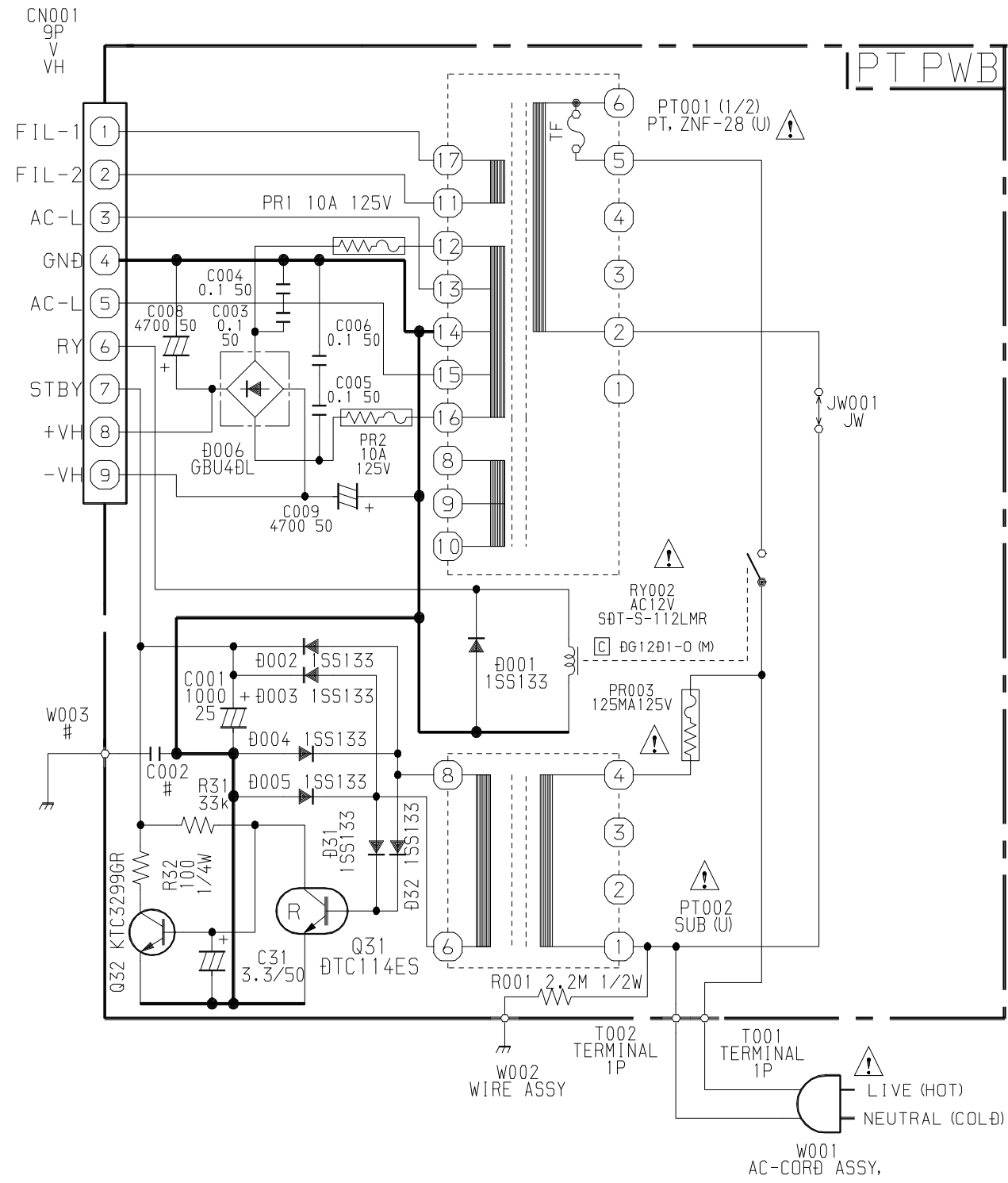

SCHEMATIC DIAGRAM (PT)

ZNF-28 U

CX-NMA545

17 DEC 1998

サービス技術ニュース	
番号	連絡内容
G- -	
G- -	
G- -	

アイワ株式会社
AIWA CO.,LTD.

9820527

Tokyo Japan