

# aiwa



## NSX-MT725

---

COMPACT DISC STEREO  
CASSETTE RECEIVER

---

• TYPE: U

SIMPLE MANUAL

• Replace this Service Manual with "Revision Publishing" when it is issued.

S/M Code No. 09-992-404-0T1

MANUAL  
SERVICE

# ELECTRICAL MAIN PARTS LIST - 1/8

NOTE: The characters in the suffix column indicate the part usage.

U	REF.NO	PARTS NO.	XX KANRI NO.	DESCRIPTION	A SUFFIX
C	606	87-010-112-040		CAP,E 100-16	A.....
C	608	87-010-178-080		CHIP CAP 1000P	A.....
C	601	87-010-186-080		CAP,CHIP 4700P	A.....
C	607	87-010-196-080		CHIP CAPACITOR,0.1-25	A.....
C	605	87-010-196-080		CHIP CAPACITOR,0.1-25	A.....
C	603	87-010-320-080		CHIP CAP 68P	A.....
C	602	87-010-405-040		CAP,E 10-50	A.....
C	604	87-010-546-040		CAP,E 0.33-50	A.....
C	652	87-010-183-080		C-CAP,S 2700P-50 B	A.....
C	653	87-010-213-080		C-CAP,S 0.015-50 B	A.....
FB	601	87-A50-190-080		C-COIL,S BLM21A102S	A.....
J	601	87-A60-651-010		JACK,3.5MONO	A.....
J	602	87-A60-651-010		JACK,3.5MONO	A.....
Q	604	87-A30-075-080		C-TR,2SA1235F	A.....
Q	603	87-A30-076-080		C-TR,2SC3052F	A.....
Q	602	87-A30-076-080		C-TR,2SC3052F	A.....
Q	601	87-A30-087-080		C-FET,2SK2158	A.....
C	1	87-010-387-080		CAP,E 470-25 SME	A.....
C	9	87-016-520-090		CAP,E 3300-65	A.....
C	8	87-016-520-090		CAP,E 3300-65	A.....
C	3	87-018-209-080		CAP,CER 0.1-50V	A.....
C	6	87-018-209-080		CAP,CER 0.1-50V	A.....
C	5	87-018-209-080		CAP,CER 0.1-50V	A.....
C	4	87-018-209-080		CAP,CER 0.1-50V	A.....
C	31	87-010-403-040		CAP,E 3.3-50 SME	A.....
CN	1	87-A60-851-010		CONN,9P V VH	A.....
D	6	87-017-447-010		DIODE,GBU4DL	A.....
D	3	87-020-465-080		DIODE,1SS133 (110MA)	A.....
D	5	87-020-465-080		DIODE,1SS133 (110MA)	A.....
D	4	87-020-465-080		DIODE,1SS133 (110MA)	A.....
D	2	87-020-465-080		DIODE,1SS133 (110MA)	A.....
D	1	87-020-465-080		DIODE,1SS133 (110MA)	A.....
D	32	87-020-465-080		DIODE,1SS133 (110MA)	A.....
D	31	87-020-465-080		DIODE,1SS133 (110MA)	A.....
PR	1	87-026-691-080		FUSE,10A 125V 251	A.....
PR	2	87-026-691-080		FUSE,10A 125V 251	A.....
PR	3	87-A91-276-080		FUSE,125MA 125V F 251	A.....
PT	2	8Z-NF8-661-010		PT,SUB ZNF-8(U)	A.....
Q	31	87-026-245-080		TR,DTC114ES	A.....
Q	32	87-A30-198-080		TR,KTC3199GR	A.....
RY	2	87-A90-976-010		RELAY,AC12V SDT-S-112LMR	A.....
T	2	87-A60-317-010		TERMINAL,1P MSC	A.....
T	1	87-A60-317-010		TERMINAL,1P MSC	A.....
		8Z-NF7-201-010		GUIDE,FUNCTION	A.....
		8Z-NF7-202-010		GUIDE,PLAY	A.....
		8Z-NF7-203-010		GUIDE,CD	A.....
C	103	87-010-178-080		CHIP CAP 1000P	A.....
C	106	87-010-312-080		C-CAP,S 15P-50 CH	A.....
C	105	87-010-322-080		C-CAP,S 100P-50 CH	A.....
C	108	87-010-405-040		CAP,E 10-50	A.....
C	107	87-012-157-080		C-CAP,S 330P-50 CH	A.....
C	114	87-010-196-080		CHIP CAPACITOR,0.1-25	A.....
C	115	87-010-198-080		CAP,CHIP 0.022	A.....
C	116	87-010-493-040		CAP,E 0.47-50 GAS	A.....
C	117	87-010-498-040		CAP,E 10-16 GAS	A.....
C	112	87-016-081-080		C-CAP,S 0.1-16 RK	A.....
C	113	87-A10-189-040		CAP,E 220-10	A.....
C	111	87-A10-189-040		CAP,E 220-10	A.....
C	122	87-010-178-080		CHIP CAP 1000P	A.....
C	125	87-010-196-080		CHIP CAPACITOR,0.1-25	A.....
C	123	87-010-196-080		CHIP CAPACITOR,0.1-25	A.....
C	124	87-010-196-080		CHIP CAPACITOR,0.1-25	A.....
C	126	87-012-145-080		CAP,CHIP S 270P CH	A.....
C	121	87-012-368-080		C-CAP,S 0.1-50 F	A.....
C	151	87-010-194-080		CAP,CHIP 0.047	A.....
C	153	87-010-196-080		CHIP CAPACITOR,0.1-25	A.....
C	154	87-010-264-040		CAP,E 100-10 5L	A.....
C	183	87-010-182-080		C-CAP,S 2200P-50 B	A.....
C	182	87-010-197-080		CAP,CHIP 0.01 DM	A.....
C	181	87-012-157-080		C-CAP,S 330P-50 CH	A.....
C	202	87-012-140-080		CAP 470P	A.....
C	221	87-010-404-040		CAP,E 4.7-50 SME	A.....
C	222	87-010-404-040		CAP,E 4.7-50 SME	A.....
C	223	87-010-408-040		CAP,E 47-50 SME	A.....
C	224	87-012-369-080		C-CAP,S 0.047-50F	A.....
C	386	87-010-196-080		CHIP CAPACITOR,0.1-25	A.....
C	381	87-010-196-080		CHIP CAPACITOR,0.1-25	A.....
C	387	87-010-196-080		CHIP CAPACITOR,0.1-25	A.....
C	383	87-010-196-080		CHIP CAPACITOR,0.1-25	A.....
C	385	87-010-196-080		CHIP CAPACITOR,0.1-25	A.....
C	384	87-010-196-080		CHIP CAPACITOR,0.1-25	A.....
C	382	87-012-158-080		C-CAP,S 390P-50 CH	A.....
C	401	87-010-196-080		CHIP CAPACITOR,0.1-25	A.....
C	402	87-010-196-080		CHIP CAPACITOR,0.1-25	A.....
C	403	87-010-322-080		C-CAP,S 100P-50 CH	A.....
C	408	87-010-322-080		C-CAP,S 100P-50 CH	A.....

# ELECTRICAL MAIN PARTS LIST - 2/8

C	407	87-010-322-080	C-CAP,S 100P-50 CH	A.....
C	406	87-010-322-080	C-CAP,S 100P-50 CH	A.....
C	405	87-010-322-080	C-CAP,S 100P-50 CH	A.....
C	404	87-010-322-080	C-CAP,S 100P-50 CH	A.....
C	411	87-010-401-040	CAP,E 1-50 SME	A.....
CN	101	87-099-720-010	CONN,30P TYK-B(P)	A.....
CN	104	87-A60-140-010	CONN,15P V FE	A.....
CN	301	87-A60-131-010	CONN,6P V FE	A.....
CN	302	87-A60-131-010	CONN,6P V FE	A.....
CN	901	87-A60-138-010	CONN,13P V FE	A.....
D	104	87-020-465-080	DIODE,1SS133 (110MA)	A.....
D	108	87-020-465-080	DIODE,1SS133 (110MA)	A.....
D	103	87-020-465-080	DIODE,1SS133 (110MA)	A.....
D	107	87-A40-270-080	C-DIODE,MC2838	A.....
D	109	87-A40-509-080	ZENER,MTZJ6.8C	A.....
D	111	87-020-465-080	DIODE,1SS133 (110MA)	A.....
D	302	87-020-465-080	DIODE,1SS133 (110MA)	A.....
D	306	87-020-465-080	DIODE,1SS133 (110MA)	A.....
D	307	87-020-465-080	DIODE,1SS133 (110MA)	A.....
D	303	87-020-465-080	DIODE,1SS133 (110MA)	A.....
D	308	87-020-465-080	DIODE,1SS133 (110MA)	A.....
D	305	87-020-465-080	DIODE,1SS133 (110MA)	A.....
D	304	87-020-465-080	DIODE,1SS133 (110MA)	A.....
D	301	87-020-465-080	DIODE,1SS133 (110MA)	A.....
D	309	87-020-465-080	DIODE,1SS133 (110MA)	A.....
D	315	87-020-465-080	DIODE,1SS133 (110MA)	A.....
D	316	87-020-465-080	DIODE,1SS133 (110MA)	A.....
D	311	87-020-465-080	DIODE,1SS133 (110MA)	A.....
D	318	87-020-465-080	DIODE,1SS133 (110MA)	A.....
D	313	87-020-465-080	DIODE,1SS133 (110MA)	A.....
D	319	87-020-465-080	DIODE,1SS133 (110MA)	A.....
D	310	87-020-465-080	DIODE,1SS133 (110MA)	A.....
D	314	87-020-465-080	DIODE,1SS133 (110MA)	A.....
D	312	87-020-465-080	DIODE,1SS133 (110MA)	A.....
D	385	87-017-932-080	ZENER,MTJ6.2B	A.....
D	384	87-020-465-080	DIODE,1SS133 (110MA)	A.....
D	383	87-020-465-080	DIODE,1SS133 (110MA)	A.....
D	382	87-020-465-080	DIODE,1SS133 (110MA)	A.....
D	381	87-020-465-080	DIODE,1SS133 (110MA)	A.....
D	701	87-A40-269-080	C-DIODE,MC2836	A.....
FL	201	8Z-NF7-610-010	FL,BJ679GK	A.....
IC	102	87-A20-951-010	IC,TSOP1838RF1	A.....
IC	101	8Z-NF7-605-010	C-IC,LC876572W-****	A.....
IC	380	87-A21-023-040	C-IC,BA3835F	A.....
IC	402	87-A21-021-040	C-IC,BU2099FV	A.....
IC	401	87-A21-021-040	C-IC,BU2099FV	A.....
L	101	87-A50-333-010	COIL,OSC 9.43MHZ	A.....
LED	293	87-A40-589-040	LED,SLR-56VCT31 RED	A.....
LED	402	87-A40-317-080	LED,SLR-342VCT31 RED	A.....
LED	404	87-A40-317-080	LED,SLR-342VCT31 RED	A.....
LED	403	87-A40-317-080	LED,SLR-342VCT31 RED	A.....
LED	401	87-A40-317-080	LED,SLR-342VCT31 RED	A.....
LED	405	87-A40-317-080	LED,SLR-342VCT31 RED	A.....
LED	406	87-A40-496-040	LED,SLR-342MCT31 GRN	A.....
LED	407	87-A40-496-040	LED,SLR-342MCT31 GRN	A.....
LED	408	87-A40-496-040	LED,SLR-342MCT31 GRN	A.....
LED	409	87-A40-496-040	LED,SLR-342MCT31 GRN	A.....
LED	413	87-A40-496-040	LED,SLR-342MCT31 GRN	A.....
LED	414	87-A40-496-040	LED,SLR-342MCT31 GRN	A.....
LED	411	87-A40-496-040	LED,SLR-342MCT31 GRN	A.....
LED	410	87-A40-496-040	LED,SLR-342MCT31 GRN	A.....
LED	412	87-A40-496-040	LED,SLR-342MCT31 GRN	A.....
LED	415	87-A40-496-040	LED,SLR-342MCT31 GRN	A.....
LED	418	87-A40-619-080	LED,SLR-56PT-TE7-W GRN	A.....
LED	417	87-A40-619-080	LED,SLR-56PT-TE7-W GRN	A.....
LED	416	87-A40-619-080	LED,SLR-56PT-TE7-W GRN	A.....
LED	419	87-A40-619-080	LED,SLR-56PT-TE7-W GRN	A.....
LED	421	87-A40-619-080	LED,SLR-56PT-TE7-W GRN	A.....
LED	420	87-A40-619-080	LED,SLR-56PT-TE7-W GRN	A.....
LED	439	87-A40-317-080	LED,SLR-342VCT31 RED	A.....
LED	438	87-A40-317-080	LED,SLR-342VCT31 RED	A.....
LED	440	87-A40-317-080	LED,SLR-342VCT31 RED	A.....
LED	444	87-A40-637-040	LED,SLV-312MC GRN	A.....
LED	441	87-A40-637-040	LED,SLV-312MC GRN	A.....
LED	443	87-A40-637-040	LED,SLV-312MC GRN	A.....
LED	442	87-A40-637-040	LED,SLV-312MC GRN	A.....
LED	445	87-A40-637-040	LED,SLV-312MC GRN	A.....
LED	451	87-A40-589-040	LED,SLR-56VCT31 RED	A.....
LED	450	87-A40-589-040	LED,SLR-56VCT31 RED	A.....
LED	452	87-A40-589-040	LED,SLR-56VCT31 RED	A.....
LED	486	87-A40-619-040	LED,SLR-56PT-T31-W GRN	A.....
LED	481	87-A40-619-040	LED,SLR-56PT-T31-W GRN	A.....
LED	487	87-A40-619-040	LED,SLR-56PT-T31-W GRN	A.....
LED	483	87-A40-619-040	LED,SLR-56PT-T31-W GRN	A.....
LED	488	87-A40-619-040	LED,SLR-56PT-T31-W GRN	A.....
LED	485	87-A40-619-040	LED,SLR-56PT-T31-W GRN	A.....
LED	484	87-A40-619-040	LED,SLR-56PT-T31-W GRN	A.....
LED	482	87-A40-619-040	LED,SLR-56PT-T31-W GRN	A.....
Q	102	87-026-610-080	TR,KTC3198GR	A.....
Q	108	87-A30-073-080	C-TR,RT1N 141C	A.....
Q	103	87-A30-087-080	C-FET,2SK2158	A.....
Q	104	87-A30-087-080	C-FET,2SK2158	A.....

# ELECTRICAL MAIN PARTS LIST - 3/8

Q	101	87-A30-087-080	C-FET,2SK2158	A.....
Q	262	87-A30-159-080	C-TR,KTA1298Y	A.....
Q	301	87-A30-076-080	C-TR,2SC3052F	A.....
Q	703	87-A30-159-080	C-TR,KTA1298Y	A.....
Q	702	87-A30-159-080	C-TR,KTA1298Y	A.....
Q	701	87-A30-240-080	TR,CSA1585BC	A.....
R	209	87-012-157-080	C-CAP,S 330P-50 CH	A.....
R	213	87-012-157-080	C-CAP,S 330P-50 CH	A.....
R	210	87-012-157-080	C-CAP,S 330P-50 CH	A.....
S	101	87-A90-471-010	SW,RTRY EC16B24304-25 NON	A.....
S	102	87-A91-018-010	SW,RTRY EC12E12504ENC-30	A.....
S	308	87-A90-095-080	SW,TACT EVQ11G04M	A.....
S	301	87-A90-095-080	SW,TACT EVQ11G04M	A.....
S	302	87-A90-095-080	SW,TACT EVQ11G04M	A.....
S	307	87-A90-095-080	SW,TACT EVQ11G04M	A.....
S	303	87-A90-095-080	SW,TACT EVQ11G04M	A.....
S	309	87-A90-095-080	SW,TACT EVQ11G04M	A.....
S	315	87-A90-095-080	SW,TACT EVQ11G04M	A.....
S	314	87-A90-095-080	SW,TACT EVQ11G04M	A.....
S	311	87-A90-095-080	SW,TACT EVQ11G04M	A.....
S	313	87-A90-095-080	SW,TACT EVQ11G04M	A.....
S	312	87-A90-095-080	SW,TACT EVQ11G04M	A.....
S	310	87-A90-095-080	SW,TACT EVQ11G04M	A.....
S	323	87-A90-095-080	SW,TACT EVQ11G04M	A.....
S	326	87-A90-095-080	SW,TACT EVQ11G04M	A.....
S	327	87-A90-095-080	SW,TACT EVQ11G04M	A.....
S	321	87-A90-095-080	SW,TACT EVQ11G04M	A.....
S	328	87-A90-095-080	SW,TACT EVQ11G04M	A.....
S	325	87-A90-095-080	SW,TACT EVQ11G04M	A.....
S	324	87-A90-095-080	SW,TACT EVQ11G04M	A.....
S	322	87-A90-095-080	SW,TACT EVQ11G04M	A.....
S	329	87-A90-095-080	SW,TACT EVQ11G04M	A.....
S	334	87-A90-095-080	SW,TACT EVQ11G04M	A.....
S	333	87-A90-095-080	SW,TACT EVQ11G04M	A.....
S	332	87-A90-095-080	SW,TACT EVQ11G04M	A.....
S	335	87-A90-095-080	SW,TACT EVQ11G04M	A.....
S	344	87-A90-095-080	SW,TACT EVQ11G04M	A.....
S	346	87-A90-095-080	SW,TACT EVQ11G04M	A.....
S	342	87-A90-095-080	SW,TACT EVQ11G04M	A.....
S	348	87-A90-095-080	SW,TACT EVQ11G04M	A.....
S	341	87-A90-095-080	SW,TACT EVQ11G04M	A.....
S	343	87-A90-095-080	SW,TACT EVQ11G04M	A.....
S	345	87-A90-095-080	SW,TACT EVQ11G04M	A.....
S	349	87-A90-095-080	SW,TACT EVQ11G04M	A.....
S	350	87-A90-095-080	SW,TACT EVQ11G04M	A.....
S	355	87-A90-095-080	SW,TACT EVQ11G04M	A.....
S	352	87-A90-095-080	SW,TACT EVQ11G04M	A.....
S	351	87-A90-095-080	SW,TACT EVQ11G04M	A.....
S	354	87-A90-095-080	SW,TACT EVQ11G04M	A.....
S	353	87-A90-095-080	SW,TACT EVQ11G04M	A.....
C	802	87-010-176-080	C-CAP,S 680P-50 SL	A.....
C	803	87-010-187-080	CAP CHIP S5600P	A.....
C	807	87-010-196-080	CHIP CAPACITOR,0.1-25	A.....
C	804	87-010-213-080	C-CAP,S 0.015-50 B	A.....
C	806	87-010-401-040	CAP,E 1-50 SME	A.....
C	809	87-012-155-080	C-CAP 180P-50CH	A.....
C	801	87-012-156-080	C-CAP,S 220P-50 CH	A.....
C	810	87-010-263-040	CAP,E 100-10	A.....
C	811	87-010-382-040	CAP,E 22-25 SME	A.....
C	812	87-010-405-040	CAP,E 10-50	A.....
D	801	87-017-931-080	ZENER,MTZJ5.6B	A.....
IC	801	87-A21-051-040	C-IC,BU9990-03FS	A.....
L	801	87-A50-093-010	COIL,CLOCK 5.76MHZ	A.....
C	309	87-010-196-080	CHIP CAPACITOR,0.1-25	A.....
C	307	87-010-196-080	CHIP CAPACITOR,0.1-25	A.....
C	302	87-010-318-080	C-CAP,S 47P-50 CH	A.....
C	301	87-010-318-080	C-CAP,S 47P-50 CH	A.....
C	305	87-012-145-080	CAP,CHIP S 270P CH	A.....
C	306	87-012-145-080	CAP,CHIP S 270P CH	A.....
C	303	87-012-157-080	C-CAP,S 330P-50 CH	A.....
C	304	87-012-157-080	C-CAP,S 330P-50 CH	A.....
C	313	87-010-178-080	CHIP CAP 1000P	A.....
C	315	87-010-178-080	CHIP CAP 1000P	A.....
C	316	87-010-178-080	CHIP CAP 1000P	A.....
C	314	87-010-178-080	CHIP CAP 1000P	A.....
C	310	87-010-196-080	CHIP CAPACITOR,0.1-25	A.....
C	312	87-010-198-080	CAP,CHIP 0.022	A.....
C	311	87-010-198-080	CAP,CHIP 0.022	A.....
C	324	87-010-260-080	CAP,ELECT 47-25V	A.....
C	325	87-010-370-080	CAP,E 330-6.3 SME	A.....
C	327	87-010-404-080	CAP,ELECT 4.7-50V	A.....
C	328	87-010-404-080	CAP,ELECT 4.7-50V	A.....
C	322	87-016-492-080	C-CAP,S 0.33-16 FZ	A.....
C	321	87-016-492-080	C-CAP,S 0.33-16 FZ	A.....
C	332	87-010-196-080	CHIP CAPACITOR,0.1-25	A.....
C	339	87-010-196-080	CHIP CAPACITOR,0.1-25	A.....
C	337	87-010-196-080	CHIP CAPACITOR,0.1-25	A.....
C	336	87-010-401-080	CAP,ELECT 1-50V	A.....
C	335	87-010-401-080	CAP,ELECT 1-50V	A.....
C	340	87-010-196-080	CHIP CAPACITOR,0.1-25	A.....
C	354	87-010-175-080	CAP 560P	A.....
C	359	87-010-183-080	C-CAP,S 2700P-50 B	A.....

# ELECTRICAL MAIN PARTS LIST - 4/8

C	358	87-010-183-080	C-CAP,S 2700P-50 B	A.....
C	357	87-010-197-080	CAP, CHIP 0.01 DM	A.....
C	356	87-010-260-080	CAP, ELECT 47-25V	A.....
C	351	87-012-140-080	CAP 470P	A.....
C	352	87-012-140-080	CAP 470P	A.....
C	355	87-012-349-080	C-CAP,S 1000P-50 CH	A.....
C	360	87-010-183-080	C-CAP,S 2700P-50 B	A.....
C	378	87-010-196-080	CHIP CAPACITOR,0.1-25	A.....
C	370	87-010-196-080	CHIP CAPACITOR,0.1-25	A.....
C	379	87-010-382-080	CAP, ELECT 22-25V	A.....
C	374	87-016-083-080	C-CAP,S 0.15-16 RK	A.....
C	373	87-016-083-080	C-CAP,S 0.15-16 RK	A.....
C	386	87-010-196-080	CHIP CAPACITOR,0.1-25	A.....
C	381	87-010-197-080	CAP, CHIP 0.01 DM	A.....
C	383	87-010-197-080	CAP, CHIP 0.01 DM	A.....
C	382	87-010-312-080	C-CAP,S 15P-50 CH	A.....
C	380	87-010-382-080	CAP, ELECT 22-25V	A.....
C	384	87-010-402-080	CAP, ELECT 2.2-50V	A.....
C	387	87-012-145-080	CAP, CHIP S 270P CH	A.....
C	388	87-012-156-080	C-CAP,S 220P-50 CH	A.....
C	393	87-010-319-080	C-CAP,S 56P-50 CH	A.....
C	394	87-010-319-080	C-CAP,S 56P-50 CH	A.....
C	391	87-010-319-080	C-CAP,S 56P-50 CH	A.....
C	392	87-010-319-080	C-CAP,S 56P-50 CH	A.....
CN	301	87-099-827-010	CONN,3P S2M-3W	A.....
CN	351	87-099-832-010	CONN,8P S2M-8W	A.....
D	352	87-A40-269-080	C-DIODE,MC2836	A.....
IC	303	87-A20-783-040	C-IC,BA7762AFS	A.....
L	301	87-A50-049-010	COIL,TRAP 85K(COI)	A.....
L	302	87-A50-049-010	COIL,TRAP 85K(COI)	A.....
L	351	87-007-342-010	COIL,OSC 85K BIAS	A.....
Q	359	87-026-610-080	TR,KTC3198GR	A.....
Q	357	87-026-610-080	TR,KTC3198GR	A.....
Q	358	87-026-610-080	TR,KTC3198GR	A.....
Q	353	87-A30-087-080	C-FET,2SK2158	A.....
Q	351	87-A30-087-080	C-FET,2SK2158	A.....
Q	354	87-A30-087-080	C-FET,2SK2158	A.....
Q	355	87-A30-105-080	C-TR,RT1P 441C	A.....
Q	383	87-A30-075-080	C-TR,2SA1235F	A.....
Q	382	87-A30-076-080	C-TR,2SC3052F	A.....
Q	381	87-A30-076-080	C-TR,2SC3052F	A.....
SFR	352	87-A90-433-080	SFR,50K H NVZ6TLTA	A.....
SFR	351	87-A90-433-080	SFR,50K H NVZ6TLTA	A.....
C	407	87-010-188-080	CAP,CHIP 6800P	A.....
C	408	87-010-188-080	CAP,CHIP 6800P	A.....
C	401	87-010-196-080	CHIP CAPACITOR,0.1-25	A.....
C	402	87-010-260-080	CAP, ELECT 47-25V	A.....
C	404	87-010-404-080	CAP, ELECT 4.7-50V	A.....
C	406	87-010-404-080	CAP, ELECT 4.7-50V	A.....
C	405	87-010-404-080	CAP, ELECT 4.7-50V	A.....
C	403	87-010-404-080	CAP, ELECT 4.7-50V	A.....
C	409	87-012-140-080	CAP 470P	A.....
C	415	87-010-197-080	CAP, CHIP 0.01 DM	A.....
C	416	87-010-197-080	CAP, CHIP 0.01 DM	A.....
C	419	87-010-260-080	CAP, ELECT 47-25V	A.....
C	414	87-010-404-080	CAP, ELECT 4.7-50V	A.....
C	413	87-010-404-080	CAP, ELECT 4.7-50V	A.....
C	412	87-010-404-080	CAP, ELECT 4.7-50V	A.....
C	411	87-010-404-080	CAP, ELECT 4.7-50V	A.....
C	418	87-010-956-080	CHIP-CAP,S 0.068-25B	A.....
C	417	87-010-956-080	CHIP-CAP,S 0.068-25B	A.....
C	410	87-012-140-080	CAP 470P	A.....
D	402	87-020-465-080	DIODE,1SS133 (110MA)	A.....
D	401	87-A40-269-080	C-DIODE,MC2836	A.....
IC	401	87-A21-022-040	C-IC,BA3880FS	A.....
C	451	87-010-404-080	CAP, ELECT 4.7-50V	A.....
C	452	87-010-404-080	CAP, ELECT 4.7-50V	A.....
C	467	87-016-314-080	C-CAP,S 1-16 F	A.....
C	5	87-067-579-010	TAPPING SCREW, BVT2+3-8	A.....
C	6	87-012-368-080	C-CAP,S 0.1-50 F	A.....
C	3	87-012-368-080	C-CAP,S 0.1-50 F	A.....
C	4	87-012-368-080	C-CAP,S 0.1-50 F	A.....
C	1	87-012-369-080	C-CAP,S 0.047-50F	A.....
C	2	87-012-369-080	C-CAP,S 0.047-50F	A.....
C	9	87-016-658-090	CAP,E 4700-35 SMG	A.....
C	10	87-016-658-090	CAP,E 4700-35 SMG	A.....
C	26	87-010-263-080	CAP, ELECT 100-10V	A.....
C	28	87-010-263-080	CAP, ELECT 100-10V	A.....
C	29	87-010-384-080	CAP, ELECT 100-25V	A.....
C	21	87-010-385-080	CAP, ELECT 220-25V	A.....
C	24	87-010-385-080	CAP, ELECT 220-25V	A.....
C	23	87-010-385-080	CAP, ELECT 220-25V	A.....
C	22	87-010-385-080	CAP, ELECT 220-25V	A.....
C	25	87-010-430-080	CAP, ELECT 100-63	A.....
C	27	87-012-140-080	CAP 470P	A.....
C	30	87-010-112-080	CAP, ELECT 100-16V	A.....
C	31	87-010-235-080	CAP,E 470-16 SME	A.....
C	61	87-010-260-080	CAP, ELECT 47-25V	A.....
C	62	87-010-496-080	CAP,E 3.3-50 5L	A.....
CNA	1	8Z-NF8-669-010	CONN ASSY,9P VH	A.....
D	1	87-017-654-060	DIODE,GBU6J	A.....

# ELECTRICAL MAIN PARTS LIST - 5/8

D	9	87-020-465-080	DIODE,1SS133 (110MA)	A.....
D	8	87-020-465-080	DIODE,1SS133 (110MA)	A.....
D	4	87-070-274-080	DIODE,1N4003 SEM	A.....
D	3	87-070-274-080	DIODE,1N4003 SEM	A.....
D	6	87-070-274-080	DIODE,1N4003 SEM	A.....
D	5	87-070-274-080	DIODE,1N4003 SEM	A.....
D	7	87-A40-341-080	ZENER,MTZJ 36 A	A.....
D	10	87-A40-345-080	ZENER,MTZJ10C	A.....
D	64	87-070-274-080	DIODE,1N4003 SEM	A.....
D	62	87-A40-269-080	C-DIODE,MC2836	A.....
D	61	87-A40-270-080	C-DIODE,MC2838	A.....
Q	2	87-026-609-080	TR,KTA1266GR	A.....
Q	1	87-026-609-080	TR,KTA1266GR	A.....
Q	5	87-026-610-080	TR,KTC3198GR	A.....
Q	8	87-A30-075-080	C-TR,2SA1235F	A.....
Q	7	87-A30-075-080	C-TR,2SA1235F	A.....
Q	6	87-A30-076-080	C-TR,2SC3052F	A.....
Q	9	87-A30-234-080	TR,CSC4115BC	A.....
Q	3	89-213-702-010	TR,2SB1370 (1.8W)	A.....
Q	4	89-213-702-010	TR,2SB1370 (1.8W)	A.....
Q	66	87-A30-075-080	C-TR,2SA1235F	A.....
Q	64	87-A30-075-080	C-TR,2SA1235F	A.....
Q	67	87-A30-076-080	C-TR,2SC3052F	A.....
Q	63	87-A30-076-080	C-TR,2SC3052F	A.....
Q	65	87-A30-076-080	C-TR,2SC3052F	A.....
FR	20	87-A00-261-080	RES,M/F 0.56-1W J	A.....
WH	1	87-A90-510-010	HLD R,WIRE 2.5-9P	A.....
		87-067-703-010	TAPPING SCREW, BVT2+3-10	A.....
C	32	87-012-368-080	C-CAP,S 0.1-50 F	A.....
C	33	87-016-299-080	CAP,E 10-100 SME	A.....
C	34	87-016-299-080	CAP,E 10-100 SME	A.....
C	101	87-010-183-080	C-CAP,S 2700P-50 B	A.....
C	102	87-010-183-080	C-CAP,S 2700P-50 B	A.....
C	105	87-010-186-080	CAP,CHIP 4700P	A.....
C	106	87-010-186-080	CAP,CHIP 4700P	A.....
C	108	87-010-403-080	CAP,ELECT 3.3-50V	A.....
C	107	87-010-403-080	CAP,ELECT 3.3-50V	A.....
C	104	87-010-546-080	CAP,ELECT 0.33-50V	A.....
C	103	87-010-546-080	CAP,ELECT 0.33-50V	A.....
C	112	87-010-260-080	CAP,ELECT 47-25V	A.....
C	111	87-010-260-080	CAP,ELECT 47-25V	A.....
C	118	87-016-247-080	C-CAP,0.1-50 F	A.....
C	117	87-016-247-080	C-CAP,0.1-50 F	A.....
C	114	87-A10-812-080	C-CAP,S 220P-200 J CH	A.....
C	113	87-A10-812-080	C-CAP,S 220P-200 J CH	A.....
C	121	87-010-186-080	CAP,CHIP 4700P	A.....
C	122	87-010-186-080	CAP,CHIP 4700P	A.....
C	126	87-012-368-080	C-CAP,S 0.1-50 F	A.....
C	125	87-012-368-080	C-CAP,S 0.1-50 F	A.....
C	127	87-012-368-080	C-CAP,S 0.1-50 F	A.....
C	128	87-012-368-080	C-CAP,S 0.1-50 F	A.....
C	136	87-010-196-080	CHIP CAPACITOR,0.1-25	A.....
C	133	87-010-197-080	CAP,CHIP 0.01 DM	A.....
D	14	87-020-465-080	DIODE,1SS133 (110MA)	A.....
D	15	87-020-465-080	DIODE,1SS133 (110MA)	A.....
D	12	87-020-465-080	DIODE,1SS133 (110MA)	A.....
D	11	87-020-465-080	DIODE,1SS133 (110MA)	A.....
D	13	87-020-465-080	DIODE,1SS133 (110MA)	A.....
D	19	87-A40-183-090	DIODE,RK36(F)	A.....
D	16	87-A40-345-080	ZENER,MTZJ10C	A.....
D	24	87-070-136-080	ZENER,MTZJ5.1B	A.....
D	23	87-070-136-080	ZENER,MTZJ5.1B	A.....
D	20	87-A40-183-090	DIODE,RK36(F)	A.....
D	25	87-A40-345-080	ZENER,MTZJ10C	A.....
D	104	87-020-465-080	DIODE,1SS133 (110MA)	A.....
D	101	87-020-465-080	DIODE,1SS133 (110MA)	A.....
D	103	87-020-465-080	DIODE,1SS133 (110MA)	A.....
D	102	87-020-465-080	DIODE,1SS133 (110MA)	A.....
D	109	87-020-465-080	DIODE,1SS133 (110MA)	A.....
D	108	87-A40-488-080	DIODE,1SS244	A.....
D	107	87-A40-488-080	DIODE,1SS244	A.....
D	111	87-020-331-080	CHIP-DIODE,DAN202K	A.....
D	113	87-020-465-080	DIODE,1SS133 (110MA)	A.....
D	115	87-020-465-080	DIODE,1SS133 (110MA)	A.....
D	112	87-020-465-080	DIODE,1SS133 (110MA)	A.....
D	114	87-020-465-080	DIODE,1SS133 (110MA)	A.....
D	110	87-020-465-080	DIODE,1SS133 (110MA)	A.....
J	203	87-033-240-010	TERMINAL,SP 4P32SV1-05	A.....
L	201	87-A60-483-010	JACK,DIA6.3 BLK ST W/S KM	A.....
L	101	87-003-383-010	COIL,1UH-S	A.....
L	102	87-003-383-010	COIL,1UH-S	A.....
Q	10	87-A30-072-080	C-TR,RT1P 144C	A.....
Q	12	87-A30-075-080	C-TR,2SA1235F	A.....
Q	11	87-A30-076-080	C-TR,2SC3052F	A.....
Q	14	87-A30-186-010	FET,2SK3053	A.....
Q	13	87-A30-186-010	FET,2SK3053	A.....
Q	61	87-A30-074-080	C-TR,RT1P 141C	A.....
Q	62	87-A30-268-040	C-TR,2SA1514K(S)	A.....
Q	108	87-A30-076-080	C-TR,2SC3052F	A.....
Q	107	87-A30-076-080	C-TR,2SC3052F	A.....
Q	109	87-A30-076-080	C-TR,2SC3052F	A.....
Q	101	87-A30-257-080	C-TR,2SD1306E	A.....

# ELECTRICAL MAIN PARTS LIST - 6/8

Q	102	87-A30-257-080	C-TR,2SD1306E	A.....
Q	104	87-A30-268-040	C-TR,2SA1514K(S)	A.....
Q	106	87-A30-268-040	C-TR,2SA1514K(S)	A.....
Q	103	87-A30-268-040	C-TR,2SA1514K(S)	A.....
Q	105	87-A30-268-040	C-TR,2SA1514K(S)	A.....
Q	110	87-A30-076-080	C-TR,2SC3052F	A.....
Q	119	87-A30-137-010	TR,2SD2494	A.....
Q	111	87-A30-190-080	TR,CC5551	A.....
Q	112	87-A30-190-080	TR,CC5551	A.....
Q	127	87-A30-075-080	C-TR,2SA1235F	A.....
Q	129	87-A30-076-080	C-TR,2SC3052F	A.....
Q	128	87-A30-076-080	C-TR,2SC3052F	A.....
Q	123	87-A30-106-070	C-TR,CMBT5551	A.....
Q	124	87-A30-106-070	C-TR,CMBT5551	A.....
Q	120	87-A30-137-010	TR,2SD2494	A.....
Q	122	87-A30-138-010	TR,2SB1625	A.....
Q	121	87-A30-138-010	TR,2SB1625	A.....
Q	126	87-A30-268-040	C-TR,2SA1514K(S)	A.....
Q	130	87-A30-076-080	C-TR,2SC3052F	A.....
Q	131	87-A30-076-080	C-TR,2SC3052F	A.....
R	129	87-A00-262-080	RES,M/F 0.15-2W J	A.....
R	130	87-A00-262-080	RES,M/F 0.15-2W J	A.....
R	131	87-A00-262-080	RES,M/F 0.15-2W J	A.....
R	132	87-A00-262-080	RES,M/F 0.15-2W J	A.....
R	143	87-A00-439-050	RES,180-1/2W J RP	A.....
R	144	87-A00-439-050	RES,180-1/2W J RP	A.....
R	145	87-A00-439-050	RES,180-1/2W J RP	A.....
R	146	87-A00-439-050	RES,180-1/2W J RP	A.....
R	165	87-A00-262-080	RES,M/F 0.15-2W J	A.....
R	166	87-A00-262-080	RES,M/F 0.15-2W J	A.....
TH	102	87-A91-042-080	C-THMS,100K 55001	A.....
TH	101	87-A91-042-080	C-THMS,100K 55001	A.....
C	203	87-010-182-080	C-CAP,S 2200P-50 B	A.....
C	204	87-010-183-080	C-CAP,S 2700P-50 B	A.....
C	202	87-010-401-080	CAP,ELECT 1-50V	A.....
C	201	87-010-401-080	CAP,ELECT 1-50V	A.....
C	209	87-010-403-080	CAP,ELECT 3.3-50V	A.....
C	214	87-010-246-080	CAP,ELECT 47-35V	A.....
C	213	87-010-258-080	CAP,E 22-35 SME	A.....
C	217	87-010-260-080	CAP,ELECT 47-25V	A.....
C	218	87-010-260-080	CAP,ELECT 47-25V	A.....
C	210	87-010-403-080	CAP,ELECT 3.3-50V	A.....
C	219	87-A10-596-080	C-CAP,S 100P-100 J CH	A.....
C	228	87-010-186-080	CAP,CHIP 4700P	A.....
C	227	87-010-186-080	CAP,CHIP 4700P	A.....
C	229	87-010-993-080	C-CAP,S 0.056-25 B	A.....
C	220	87-A10-596-080	C-CAP,S 100P-100 J CH	A.....
C	226	87-A10-712-080	C-CAP,S 0.22-50 Z F	A.....
C	225	87-A10-712-080	C-CAP,S 0.22-50 Z F	A.....
C	231	87-010-196-080	CHIP CAPACITOR,0.1-25	A.....
C	240	87-015-690-080	CAP,E 22-35 7L	A.....
C	898	87-010-993-080	C-CAP,S 0.056-25 B	A.....
C	899	87-012-368-080	C-CAP,S 0.1-50 F	A.....
D	201	87-020-465-080	DIODE,1SS133 (110MA)	A.....
D	202	87-020-465-080	DIODE,1SS133 (110MA)	A.....
D	203	87-020-465-080	DIODE,1SS133 (110MA)	A.....
D	204	87-020-465-080	DIODE,1SS133 (110MA)	A.....
D	207	87-A40-488-080	DIODE,1SS244	A.....
D	208	87-A40-488-080	DIODE,1SS244	A.....
D	211	87-020-331-080	CHIP-DIODE,DAN202K	A.....
D	213	87-020-465-080	DIODE,1SS133 (110MA)	A.....
D	214	87-020-465-080	DIODE,1SS133 (110MA)	A.....
J	204	87-A60-752-010	JACK,PIN 4P R/W,O/B	A.....
L	201	87-003-383-010	COIL,1UH-S	A.....
L	801	87-003-383-010	COIL,1UH-S	A.....
Q	203	87-A30-075-080	C-TR,2SA1235F	A.....
Q	205	87-A30-075-080	C-TR,2SA1235F	A.....
Q	206	87-A30-075-080	C-TR,2SA1235F	A.....
Q	204	87-A30-075-080	C-TR,2SA1235F	A.....
Q	209	87-A30-076-080	C-TR,2SC3052F	A.....
Q	208	87-A30-076-080	C-TR,2SC3052F	A.....
Q	207	87-A30-076-080	C-TR,2SC3052F	A.....
Q	202	87-A30-257-080	C-TR,2SD1306E	A.....
Q	201	87-A30-257-080	C-TR,2SD1306E	A.....
Q	210	87-A30-076-080	C-TR,2SC3052F	A.....
Q	219	87-A30-119-040	C-TR,2SC3906K R	A.....
Q	211	87-A30-190-080	TR,CC5551	A.....
Q	212	87-A30-190-080	TR,CC5551	A.....
Q	217	87-A30-214-010	TR,2SB1344	A.....
Q	215	87-A30-215-010	TR,2SD2025	A.....
Q	218	87-A30-255-010	TR,2SB1342	A.....
Q	216	87-A30-256-010	TR,2SD1933	A.....
Q	224	87-A30-076-080	C-TR,2SC3052F	A.....
Q	226	87-A30-076-080	C-TR,2SC3052F	A.....
Q	227	87-A30-076-080	C-TR,2SC3052F	A.....
Q	225	87-A30-076-080	C-TR,2SC3052F	A.....
Q	223	87-A30-105-080	C-TR,RT1P 441C	A.....
Q	220	87-A30-119-040	C-TR,2SC3906K R	A.....
R	231	87-A00-258-080	RES,M/F 0.22-1W J	A.....
R	232	87-A00-258-080	RES,M/F 0.22-1W J	A.....
R	233	87-A00-258-080	RES,M/F 0.22-1W J	A.....
R	234	87-A00-258-080	RES,M/F 0.22-1W J	A.....

# ELECTRICAL MAIN PARTS LIST - 7/8

R	265	87-A00-258-080	RES,M/F 0.22-1W J	A.....
R	266	87-A00-258-080	RES,M/F 0.22-1W J	A.....
C	801	87-010-176-080	C-CAP,S 680P-50 SL	A.....
C	802	87-010-176-080	C-CAP,S 680P-50 SL	A.....
C	809	87-010-196-080	CHIP CAPACITOR,0.1-25	A.....
C	808	87-010-401-080	CAP, ELECT 1-50V	A.....
C	807	87-010-401-080	CAP, ELECT 1-50V	A.....
C	806	87-010-958-080	CHIP -CAP,S 0.01-25BJ	A.....
C	805	87-010-958-080	CHIP -CAP,S 0.01-25BJ	A.....
C	804	87-010-958-080	CHIP -CAP,S 0.01-25BJ	A.....
C	803	87-010-958-080	CHIP -CAP,S 0.01-25BJ	A.....
C	810	87-010-112-080	CAP, ELECT 100-16V	A.....
C	817	87-010-221-080	CAP, ELECT 470-10V	A.....
C	813	87-010-400-080	CAP, ELECT 0.47-50V	A.....
C	812	87-010-493-080	CAP,E 0.47-50 GAS	A.....
C	811	87-010-493-080	CAP,E 0.47-50 GAS	A.....
C	814	87-010-494-080	CAP ELECT GAS 1/50	A.....
C	819	87-A10-800-080	C-CAP,S 6800P-16 J B CM	A.....
C	818	87-A10-891-080	CAP,E 4.7-25 SME(K)	A.....
C	825	87-010-196-080	CHIP CAPACITOR,0.1-25	A.....
C	821	87-010-196-080	CHIP CAPACITOR,0.1-25	A.....
C	824	87-010-374-080	CAP, ELECT 47-10V	A.....
C	820	87-010-374-080	CAP, ELECT 47-10V	A.....
C	829	87-010-545-080	CAP, ELECT 0.22-50V	A.....
C	822	87-A10-804-080	C-CAP,S 0.1-25 J B	A.....
C	839	87-010-805-080	CAP, S 1-16	A.....
C	831	87-010-971-080	C-CAP,S 4700P-50 B J	A.....
C	837	87-010-971-080	C-CAP,S 4700P-50 B J	A.....
C	830	87-012-142-080	CAP, S 0.33-16	A.....
C	838	87-012-349-080	C-CAP,S 1000P-50 CH	A.....
C	832	87-012-349-080	C-CAP,S 1000P-50 CH	A.....
C	835	87-A11-182-080	C-CAP,S 0.27-16 J B	A.....
C	834	87-A11-182-080	C-CAP,S 0.27-16 J B	A.....
C	833	87-A11-183-080	C-CAP,S 0.12-16 J B	A.....
C	836	87-A11-183-080	C-CAP,S 0.12-16 J B	A.....
C	840	87-010-401-080	CAP, ELECT 1-50V	A.....
C	846	87-010-404-080	CAP, ELECT 4.7-50V	A.....
C	847	87-010-404-080	CAP, ELECT 4.7-50V	A.....
C	845	87-012-393-080	C-CAP,S 0.22-16 R K	A.....
C	849	87-012-393-080	C-CAP,S 0.22-16 R K	A.....
C	848	87-012-393-080	C-CAP,S 0.22-16 R K	A.....
C	844	87-012-393-080	C-CAP,S 0.22-16 R K	A.....
C	843	87-A10-229-080	C-CAP,S 0.68-10 K W5	A.....
C	841	87-A10-799-080	C-CAP,S 5600P-16 J B CM	A.....
C	842	87-A10-802-080	C-CAP,S 0.047-16 J B CM	A.....
C	850	87-016-081-080	C-CAP,S 0.1-16 RK	A.....
C	857	87-016-081-080	C-CAP,S 0.1-16 RK	A.....
C	854	87-016-081-080	C-CAP,S 0.1-16 RK	A.....
C	853	87-016-081-080	C-CAP,S 0.1-16 RK	A.....
C	855	87-A10-801-080	C-CAP,S 0.022-16 J B CM	A.....
C	856	87-A10-801-080	C-CAP,S 0.022-16 J B CM	A.....
C	851	87-A10-802-080	C-CAP,S 0.047-16 J B CM	A.....
C	852	87-A10-802-080	C-CAP,S 0.047-16 J B CM	A.....
D	802	87-070-136-080	ZENER,MTZJ5.1B	A.....
J	801	87-A40-442-080	ZENER,MTZJ9.1A	A.....
IC	801	87-A20-853-010	C-IC,M62463FP	A.....
R	807	87-022-214-080	C-RES S100K-1/10WF	A.....
C	602	87-010-183-080	C-CAP,S 2700P-50 B	A.....
C	601	87-010-183-080	C-CAP,S 2700P-50 B	A.....
C	619	87-010-185-080	C-CAP,S 3900P-50 B	A.....
C	613	87-016-081-080	C-CAP,S 0.1-16 RK	A.....
C	614	87-016-081-080	C-CAP,S 0.1-16 RK	A.....
C	620	87-010-185-080	C-CAP,S 3900P-50 B	A.....
C	627	87-010-196-080	CHIP CAPACITOR,0.1-25	A.....
C	625	87-010-401-080	CAP, ELECT 1-50V	A.....
C	626	87-010-401-080	CAP, ELECT 1-50V	A.....
C	621	87-010-401-080	CAP, ELECT 1-50V	A.....
C	622	87-010-401-080	CAP, ELECT 1-50V	A.....
C	629	87-010-405-080	CAP, ELECT 10-50V	A.....
C	623	87-A10-773-080	CAP,M 0.10-50 J	A.....
C	624	87-A10-773-080	CAP,M 0.10-50 J	A.....
C	637	87-010-183-080	C-CAP,S 2700P-50 B	A.....
C	634	87-010-196-080	CHIP CAPACITOR,0.1-25	A.....
C	635	87-010-196-080	CHIP CAPACITOR,0.1-25	A.....
C	630	87-010-213-080	C-CAP,S 0.015-50 B	A.....
C	633	87-010-263-080	CAP, ELECT 100-10V	A.....
C	632	87-010-263-080	CAP, ELECT 100-10V	A.....
C	636	87-010-992-080	C-CAP,S 0.047-25 B	A.....
C	631	87-010-992-080	C-CAP,S 0.047-25 B	A.....
C	641	87-010-196-080	CHIP CAPACITOR,0.1-25	A.....
C	640	87-010-314-080	C-CAP,S 22P-50V	A.....
CN	604	87-099-570-010	CONN,13P TUC-P13P-B1	A.....
CN	601	87-099-719-010	CONN,30P TYK-B(X)	A.....
CN	602	87-A60-131-010	CONN,6P V FE	A.....
D	601	87-A40-002-080	ZENER,MTZJ5.1C	A.....
D	603	87-A40-234-080	ZENER,MTZJ5.6A	A.....
D	602	87-A40-438-080	ZENER,MTZJ4.7A	A.....
IC	601	87-A21-011-040	C-IC,M62445FP-600D	A.....
J	601	87-A60-402-010	JACK,PIN 6P R/W HSP-246V30	A.....
Q	604	87-026-444-080	C-TR,DTA123EK	A.....
Q	601	87-026-609-080	TR,KTA1266GR	A.....
C	735	87-010-178-080	CHIP CAP 1000P	A.....



# ELECTRICAL MAIN PARTS LIST - 8/8

C	733	87-010-196-080	CHIP CAPACITOR,0.1-25	A.....
C	736	87-010-196-080	CHIP CAPACITOR,0.1-25	A.....
C	731	87-010-498-080	CAP,E 10-16 GAS	A.....
C	734	87-012-156-080	C-CAP,S 220P-50 CH	A.....
Q	732	87-A30-075-080	C-TR,2SA1235F	A.....
Q	731	87-A30-076-080	C-TR,2SC3052F	A.....

# ELECTRICAL MAIN PARTS LIST - 1/3 (TUNER: ZZA-1)

NOTE: The characters in the suffix column indicate the part usage.

URTM	REF.NO	PARTS NO.	XX KANRI NO.	DESCRIPTION	C SUFFIX
C	701	87-010-381-080	0E	CAP, ELECT 330-16V	ABC.....
C	702	87-010-404-080	0E	CAP, ELECT 4.7-50V	ABC.....
C	704	87-012-286-080	0E	CAP, U 0.01-25	ABC.....
C	703	87-012-286-080	0E	CAP, U 0.01-25	ABC.....
C	711	87-010-260-080	0E	CAP, ELECT 47-25V	ABC.....
C	711	87-010-553-080	0E	CAP, E 47-16	.....
C	712	87-010-831-080	0E	C-CAP, U, 0.1-16F	ABC.....
C	718	87-012-179-080	0E	C-CAP, U 20P-50 CH	.BC.....
C	714	87-012-286-080	0E	CAP, U 0.01-25	ABC.....
C	717	87-012-286-080	0E	CAP, U 0.01-25	ABC.....
C	719	87-012-286-080	0E	CAP, U 0.01-25	ABC.....
C	727	87-010-196-080	0E	CHIP CAPACITOR, 0.1-25	ABC.....
C	728	87-010-248-080	0E	CAP, ELECT 220-10V	ABC.....
C	721	87-012-176-080	0E	CAP 15P	ABC.....
C	722	87-012-176-080	0E	CAP 15P	ABC.....
C	720	87-012-195-080	0E	C-CAP, U 100P-50CH	ABC.....
C	729	87-012-274-080	0E	CHIP CAP, U 1000P-50B	ABC.....
C	725	87-018-131-080	0E	CAP, CER 1000P-50V	.....
CN	701	87-A60-650-010	1A	CONN, 16P H GRY TUC-P16X-C1	.....
CN	701	87-A60-700-010	0E	CONN, 13P H GRY TUC-P13X-C1	ABC.....
D	721	87-017-149-080	0E	ZENER, HZS6A2L	.BC.....
D	722	87-020-465-080	0E	DIODE, 1SS133 (110MA)	.....
D	721	87-A40-234-080	0E	ZENER, MTZJ5.6A	A.....
IC	721	87-070-127-110	1C	IC, LC72131 D	ABC.....
Q	713	87-A30-072-080	0E	C-TR, RT1P 144C	.....
Q	712	87-A30-072-080	0E	C-TR, RT1P 144C	.....
Q	711	87-A30-196-080	0E	TR, 2SC4115SR	A.....
Q	711	87-A30-234-080	0E	TR, CSC4115BC	.BC.....
X	721	87-A70-061-010	1A	VIB, XTAL 4.500MHZ CSA-309	ABC.....
C	872	87-010-400-080	0E	CAP, ELECT 0.47-50V	AB.....
C	873	87-010-404-080	0E	CAP, ELECT 4.7-50V	AB.....
C	877	87-012-278-080	0E	C-CAP, U 2200P-50 B	AB.....
C	878	87-012-278-080	0E	C-CAP, U 2200P-50 B	AB.....
C	889	87-010-248-080	0E	CAP, ELECT 220-10V	AB.....
C	884	87-010-260-080	0E	CAP, ELECT 47-25V	AB.....
C	883	87-010-404-080	0E	CAP, ELECT 4.7-50V	AB.....
C	885	87-010-545-080	0E	CAP, ELECT 0.22-50V	A.....
C	886	87-010-545-080	0E	CAP, ELECT 0.22-50V	A.....
C	888	87-010-787-080	0E	CAP, U 0.022-25	AB.....
C	881	87-012-141-080	0E	CHIP-CAPACITOR, 0.22-16F	AB.....
C	882	87-012-172-080	0E	CAPACITOR CHIP U 10P CH	AB.....
C	887	87-012-286-080	0E	CAP, U 0.01-25	AB.....
C	885	87-016-460-080	0E	C-CAP, S 0.22-16 B	.B.....
C	886	87-016-460-080	0E	C-CAP, S 0.22-16 B	.B.....
IC	871	87-070-060-040	1F	IC, TA2040AF	AB.....
IC	873	87-026-226-080	0E	CHIP-TR, DTA143EK	AB.....
X	891	87-030-394-010	1B	VIB, CER CSA3.6MGF228	AB.....
C	705	87-010-213-080	0E	C-CAP, S 0.015-50 B	.....
C	706	87-010-213-080	0E	C-CAP, S 0.015-50 B	.....
C	705	87-A10-592-080	0E	C-CAP, S 0.015-50 J B	.BC.....
C	706	87-A10-592-080	0E	C-CAP, S 0.015-50 J B	.BC.....
C	733	87-010-180-080	0E	C-CER 1500P	.....
C	738	87-010-180-080	0E	C-CER 1500P	.....
C	737	87-010-180-080	0E	C-CER 1500P	.....
C	734	87-010-180-080	0E	C-CER 1500P	.....
C	735	87-010-213-080	0E	C-CAP, S 0.015-50 B	.....
C	736	87-010-213-080	0E	C-CAP, S 0.015-50 B	.....
C	736	87-010-987-080	0E	C-CAP, S 1500P-50 CH	.BC.....
C	733	87-010-987-080	0E	C-CAP, S 1500P-50 CH	.BC.....
C	735	87-010-987-080	0E	C-CAP, S 1500P-50 CH	.BC.....
C	734	87-010-987-080	0E	C-CAP, S 1500P-50 CH	.BC.....
C	734	87-012-280-080	0E	CAP, U 3300P-50	.....
C	733	87-012-280-080	0E	CAP, U 3300P-50	.....
C	738	87-A10-592-080	0E	C-CAP, S 0.015-50 J B	.BC.....
C	737	87-A10-592-080	0E	C-CAP, S 0.015-50 J B	.BC.....
C	752	87-010-220-080	0E	C-CAP, S 0.018-25 B	.B.....
C	751	87-010-220-080	0E	C-CAP, S 0.018-25 B	.B.....
C	758	87-012-167-080	0E	C-CAP, U 5P-50 CH	ABC.....
C	757	87-012-188-080	0E	C-CAP, U 47P-50 CH	ABC.....
C	753	87-012-195-080	0E	C-CAP, U 100P-50CH	.....
C	752	87-012-282-080	0E	CAP, U 4700P-50	.....
C	756	87-012-286-080	0E	CAP, U 0.01-25	ABC.....
C	751	87-012-365-080	0E	C-CAP, S 0.027-25VBK	.C.....
C	752	87-012-365-080	0E	C-CAP, S 0.027-25VBK	.C.....
C	766	87-010-197-080	0E	CAP, CHIP 0.01 DM	.....
C	769	87-010-260-080	0E	CAP, ELECT 47-25V	ABC.....
C	768	87-012-286-080	0E	CAP, U 0.01-25	ABC.....
C	765	87-012-286-080	0E	CAP, U 0.01-25	ABC.....
C	764	87-012-337-080	0E	C-CAP, U 56P-50 CH	ABC.....
C	774	87-010-263-080	0E	CAP, ELECT 100-10V	ABC.....
C	771	87-010-383-080	0E	CAP, ELECT 33-25V	ABC.....
C	777	87-010-400-080	0E	CAP, ELECT 0.47-50V	ABC.....
C	775	87-010-404-080	0E	CAP, ELECT 4.7-50V	ABC.....
C	777	87-010-493-040	0E	CAP, E 0.47-50 GAS	.....
C	777	87-010-493-080	0E	CAP, E 0.47-50 GAS	.....
C	770	87-010-829-080	0E	CAP, U 0.047-16	ABC.....

# ELECTRICAL MAIN PARTS LIST - 2/3 (TUNER: ZZA-1)

C	780	87-010-196-080	0E	CHIP CAPACITOR,0.1-25	ABC.....	
C	786	87-010-401-080	0E	CAP, ELECT 1-50V	ABC.....	
C	785	87-010-401-080	0E	CAP, ELECT 1-50V	ABC.....	
C	786	87-010-405-080	0E	CAP, ELECT 10-50V	ABC.....	
C	785	87-010-405-080	0E	CAP, ELECT 10-50V	ABC.....	
C	785	87-010-494-080	0E	CAP ELECT GAS 1/50	.....	
C	786	87-010-494-080	0E	CAP ELECT GAS 1/50	.....	
C	787	87-012-275-080	0E	C-CAP,U 1200P-50 B	ABC.....	
C	788	87-012-275-080	0E	C-CAP,U 1200P-50 B	ABC.....	
C	784	87-012-286-080	0E	CAP, U 0.01-25	ABC.....	
C	796	87-010-403-080	0E	CAP, ELECT 3.3-50V	ABC.....	
C	794	87-010-406-080	0E	CAP, ELECT 22-50	ABC.....	
C	795	87-010-596-080	0E	CAP, S 0.047-16	..C.....	
C	793	87-012-273-080	0E	C-CAP,U 820P-50 B	ABC.....	
C	797	87-012-276-080	0E	CAP, CHIP SS 1500 PBK	A.....	
C	798	87-012-276-080	0E	CAP, CHIP SS 1500 PBK	A.....	
D	771	87-020-465-080	0E	DIODE,1SS133 (110MA)	ABC.....	
D	773	87-A40-291-080	0E	DIODE,1N4148 (CPT)	.....	
IC	771	87-A20-913-010	1D	IC,LA1837NL	ABC.....	
L	771	87-A50-266-010	1A	COIL,FM DET-2N(TOK)	ABC.....	
L	772	87-A90-052-010	1C	FLTR,CFMT-450A(TOK)	.....	
L	772	87-A90-053-010	1C	FLTR,PCFMT-060(TOK)	AB.....	
L	772	87-A90-733-010	1A	FLTR,PCFAZH-450 (TOK)	.....	
L	772	87-A91-110-010	FLTR,PCFJZH-450 (TOK)	.....	..C.....	
L	781	87-005-847-080	0E	COIL,2.2UH(CECS)	.....	
L	792	87-A50-027-010	1A	COIL,1 POLE MPX(TOK)	.....	
L	791	87-A50-027-010	1A	COIL,1 POLE MPX(TOK)	.....	
X	771	87-030-354-010	1A	VIB,CF BFU 450C	.....	
C	859	87-012-286-080	0E	CAP, U 0.01-25	.....	
C	865	87-010-196-080	0E	CHIP CAPACITOR,0.1-25	.....	
C	866	87-010-405-080	0E	CAP, ELECT 10-50V	.....	
C	864	87-010-405-080	0E	CAP, ELECT 10-50V	.....	
C	869	87-012-180-080	0E	C-CAP,U 22P-50 CH	.....	
C	868	87-012-184-080	0E	C-CAP,U 33P-50 CH	.....	
C	862	87-012-199-080	0E	CAP 220P	.....	
C	861	87-012-199-080	0E	CAP 220P	.....	
C	863	87-012-270-080	0E	CAP, U 470P-50	.....	
C	867	87-012-286-080	0E	CAP, U 0.01-25	.....	
IC	851	87-A20-440-040	1H	C-IC,BU1920FS	.....	
L	851	87-005-847-080	0E	COIL,2.2UH(CECS)	.....	
Q	853	87-A30-076-080	0E	C-TR,2SC3052F	.....	
X	851	87-A70-091-010	1B	VIB,XTAL 4.332MHZ CSA-309	.....	
C	820	87-010-260-080	0E	CAP, ELECT 47-25V	ABC.....	
C	942	87-012-172-080	0E	CAPACITOR CHIP U 10P CH	.....	
C	941	87-012-180-080	0E	C-CAP,U 22P-50 CH	.....	
C	947	87-012-286-080	0E	CAP, U 0.01-25	ABC.....	
C	940	87-012-286-080	0E	CAP, U 0.01-25	ABC.....	
C	944	87-014-049-080	0E	CAP,PP 470P-100 J	.....	
C	944	87-014-051-080	0E	CAPACITOR (PP), 560P	.....	
C	949	87-A10-039-080	0E	C-CAP,U 470P-50 J CH	.....	
C	958	87-010-197-080	0E	CAP, CHIP 0.01 DM	.....	
C	956	87-010-263-080	0E	CAP, ELECT 100-10V	.....	
C	959	87-010-831-080	0E	C-CAP,U,0.1-16F	.....	
C	952	87-012-286-080	0E	CAP, U 0.01-25	ABC.....	
C	954	87-012-358-080	0E	C-CAP,S 0.47-10 F Z	.....	
C	950	87-014-073-080	0E	CAP,PP 4700P-100 J	.....	
C	963	87-010-196-080	0E	CHIP CAPACITOR,0.1-25	ABC.....	
C	962	87-010-401-080	0E	CAP, ELECT 1-50V	.....	
C	964	87-012-170-080	0E	C-CAP,U 8P-50 CH	A.....	
C	961	87-012-174-080	0E	CAP CHIP CERA SS 12P CHJ	.BC.....	
C	960	87-012-350-080	0E	C-CAP,1-25 F	.....	
CF	802	82-785-747-010	1A	CF MS2 GHY R	.....	
CF	802	87-008-261-010	1A	FILTER, SFE10.7MA5-A	ABC.....	
CF	801	87-008-261-010	1A	FILTER, SFE10.7MA5-A	ABC.....	
CF	801	87-008-423-010	1A	CERAMIC FILTER, SFE10.7	.....	
D	944	87-020-465-080	0E	DIODE,1SS133 (110MA)	.....	
D	942	87-A40-270-080	0E	C-DIODE,MC2838	.....	
FFE	801	A8-6ZA-190-030	0E	6ZA-1 FEUNM	.....	
FFE	801	A8-6ZA-191-130	6ZA-1 FEENM	.....	.....	
FFE	801	A8-6ZA-192-030	2Y	6ZA-1 FEJNM	.B.....	
FFE	801	A8-6ZA-199-170	6ZA-1 FEENC	.....	.....	
FFE	801	A8-6ZA-19A-070	6ZA-1 FEJNC	.....	.....	
FFE	801	A8-6ZA-19D-070	1H	6ZA-1 YFEJNC	A.....	
FFE	801	A8-8ZA-190-030	8ZA-1 FEUNM	.....	..C.....	
FFE	801	A8-8ZA-192-070	8ZA-1 FEUNC	.....	.....	
FFE	801	A8-8ZA-193-070	1E	8ZA-1 YFEUNC	.....	.....
J	801	87-033-241-010	1B	TERMINAL,ANT AJ-2039	.....	
J	801	87-A60-702-010	1B	TERMINAL,ANT 4P CJ-9036	ABC.....	
J	801	87-A60-703-010	1A	TERMINAL,ANT 3P CJ-9037	.....	
J	940	81-754-629-010	0E	CONNECTOR, 2P	.....	
L	832	87-005-847-080	0E	COIL,2.2UH(CECS)	.....	
L	943	87-005-372-080	0E	COIL S 1MHM	.....	
L	942	87-A50-019-010	0E	COIL,OSC LW(COI)	.....	
L	941	87-A50-020-010	0E	COIL,ANT LW(COI)	.....	
L	941	87-A50-022-010	0E	COIL,ANT SW(COI)	.....	
L	944	87-A50-159-010	0E	COIL,10MH K C2B	.....	
L	942	87-A50-173-010	0E	COIL,OSC SW-N(COI)	.....	
L	943	87-A50-432-010	COIL,1MH K CW	.....	.....	
L	981	87-A50-430-010	COIL,ANT MW(3BSW)	.....	.....	
L	982	87-A50-431-010	COIL,OSC MW(3BSW)	.....	.....	
L	981	87-NF4-650-010	1D	COIL,AM PACK 4N(TOK)	A.....	
L	981	87-NF4-651-010	1C	COIL,AM PACK2N(TOM)	.....	

# ELECTRICAL MAIN PARTS LIST - 3/3 (TUNER: ZZA-1)

L	981	88-NF8-625-110	1D	COIL,AM PACK3N(TOK)	.....
L	981	8Z-ZA1-664-010		COIL,AM PACK 4(TOK)	.BC.....
L	981	8Z-ZA1-665-010		COIL,AM PACK 2(TOK)	.....
Q	712	87-A30-072-080	0E	C-TR,RT1P 144C	ABC.....
Q	805	89-327-143-080	0E	TR,2SC2714 (0.1W)	ABC.....
Q	943	87-A30-075-080	0E	C-TR,2SA1235F	.....
Q	942	87-A30-075-080	0E	C-TR,2SA1235F	.....
Q	949	87-A30-076-080	0E	C-TR,2SC3052F	.....
Q	945	87-A30-076-080	0E	C-TR,2SC3052F	.....
Q	944	87-A30-076-080	0E	C-TR,2SC3052F	.....
Q	948	87-A30-086-070	0E	C-TR,CSD1306E	.....
Q	947	89-503-602-080	1A	C-FET,2SK360E	.....
Q	947	89-505-434-540	0E	C-FET,2SK543(4/5)	.....
Q	951	87-A30-074-080	0E	C-TR,RT1P 141C	.....
SCR	981	87-A40-618-080		VARI-CAP,SVC 348(S/T)	.....
TC	942	87-011-164-010	0E	CAPACITOR,TRIMMER 30P	.....
TC	941	87-011-173-010	1A	CERAMIC TRIMMER 20P	.....
TC	941	87-011-220-080	1A	TRIMMER CAP 20P VTC	.....
TC	943	87-011-221-080	1A	CAP, TRIMMER 30P	.....

# MECHANICAL PARTS LIST - 1/1

NOTE: The characters in the suffix column indicate the part usage.

REF.NO	PARTS NO.	XX KANRI NO.	DESCRIPTION	A SUFFIX
	82-NE6-067-010		BADGE,AIWA 30N	A.....
	86-NF6-101-110		WINDOW, TOP UL	A.....
	8Z-NB8-011-110		PANEL, LEFT V-2	A.....
	8Z-NB8-013-010		PANEL, TOP V-2	A.....
	8Z-NF7-003-010		BOX, CASS 1	A.....
	8Z-NF7-004-010		BOX, CASS 2	A.....
	8Z-NF7-005-010		PANEL, TRAY	A.....
	8Z-NF7-006-010		PANEL, CD	A.....
	8Z-NF7-007-010		REFLECTOR, CD	A.....
	8Z-NF7-009-010		WINDOW, CASS 1	A.....
	8Z-NF7-010-010		WINDOW, CASS 2	A.....
	8Z-NF7-014-010		RING, VOL	A.....
	8Z-NF7-015-010		RING, JOG	A.....
	8Z-NF7-016-010		REFLECTOR, JOG	A.....
	8Z-NF9-043-010		PANEL, RIGHT S V-2	A.....
	8Z-NFU-001-010		CABI, FR U	A.....
	8Z-NFU-013-010		WINDOW, DISPLAY U	A.....
	8Z-NFU-021-010		CABI, REAR USTM	A.....
	8Z-NF7-011-010		KNOB, RTRY VOL	A.....
	8Z-NF7-012-010		KNOB, RTRY JOG	A.....
	8Z-NF7-018-010		KEY, POWER	A.....
	8Z-NF7-019-010		KEY, CD	A.....
	8Z-NF7-021-010		KEY, KARAOKE U	A.....
	8Z-NF7-022-010		KEY, FUNCTION	A.....
	8Z-NF7-023-010		KEY, ASSY PLAY	A.....
	8Z-NF7-025-010		BTN, PLAY	A.....
	8Z-NF7-026-010		PANEL, PLAY	A.....
	8Z-NF7-027-010		KEY, NSP	A.....
	8Z-NF7-029-010		KEY, PAD	A.....
	8Z-NF7-031-010		KEY, DEMO H	A.....
	8Z-NF7-033-010		KEY, JOG H	A.....
	8Z-NF7-036-010		REFLECTOR, ECO	A.....
	8Z-NFU-011-010		KEY, PRO	A.....
	81-532-080-010		LABEL, CASS. COMPT	A.....
	86-NF6-061-010		REFLECTOR, CASS	A.....
	8Z-NFU-012-010		PLATE, PRO	A.....
	87-NF6-616-010		CONN ASSY, 8P RPB	A.....
	84-ZG1-245-210		CAP, OPTICAL	A.....
	82-NF5-218-010		SPR-T, EJECT 1 (SIN)	A.....
	82-NF5-219-010		SPR-T, EJECT 2 (SIN)	A.....
	82-NF5-229-010		PLATE, LOCK	A.....
	86-NF9-224-010		SPR-C, LOCK	A.....
	87-NF4-216-010		HLDR, LOCK 1	A.....
	87-NF4-217-010		HLDR, LOCK 2	A.....
	87-NF8-220-010		DMPR, 150	A.....
	8Z-NB8-215-010		HLDR, PWB M	A.....
	8Z-NB8-240-010		COVER, PL	A.....
	8Z-NF8-205-010		HLDR, HT-SINK	A.....
	87-067-641-010		UTT2+3-8(W/O SLOT)BL	A.....
	87-067-688-010		BVTT+3-6	A.....
	87-067-703-010		TAPPING SCREW, BVT2+3-10	A.....
	87-078-191-010		S-SCREW, IT+4-10	A.....
	87-721-096-410		QT2+3-10 GLD	A.....
	87-721-097-410		QT2+3-12 GLD	A.....
	87-723-096-410		QT2+3-10W/O SLOT BL	A.....
	87-NF4-224-010		S-SCREW, IT3B+3-8 CU	A.....
	85-NF5-617-010		CABLE, FFC 6P-1.25	A.....
	85-NF5-618-010		CABLE, FFC 13P-1.25	A.....
	88-915-121-110		FF-CABLE, 15P 1.25	A.....
PT 101	8Z-NF7-621-010		PT, U ZNF-7	A.....
W 1	87-085-189-010		BUSHING, CORD (U)	A.....
W 101	87-A80-110-010		AC CORD ASSY, U SPT-2W	A.....
	8Z-NF7-201-010		GUIDE, FUNCTION	A.....
	8Z-NF7-202-010		GUIDE, PLAY	A.....
	8Z-NF7-203-010		GUIDE, CD	A.....
	87-067-579-010		TAPPING SCREW, BVT2+3-8	A.....
WH 1	87-A90-510-010		HLDR, WIRE 2.5-9P	A.....
	87-067-703-010		TAPPING SCREW, BVT2+3-10	A.....

# ACCESSORIES / PACKAGE LIST - 1/1

NOTE: The characters in the suffix column indicate the part usage.

REF.NO	PARTS NO.	NO.	DESCRIPTION	SUFFIX
U		XX		A
		KANRI		
	8Z-NFU-903-010		IB,U(ESF)M	A.....
	87-006-225-010		AM LOOP ANT NC2	A.....
	87-043-115-010		ANT,FEEDER FM	A.....
	8Z-NFV-702-010		RC UNIT,RC-ZAS05	A.....

SCHEMATIC DIAGRAM - 1 (MAIN 1/3: AMP)

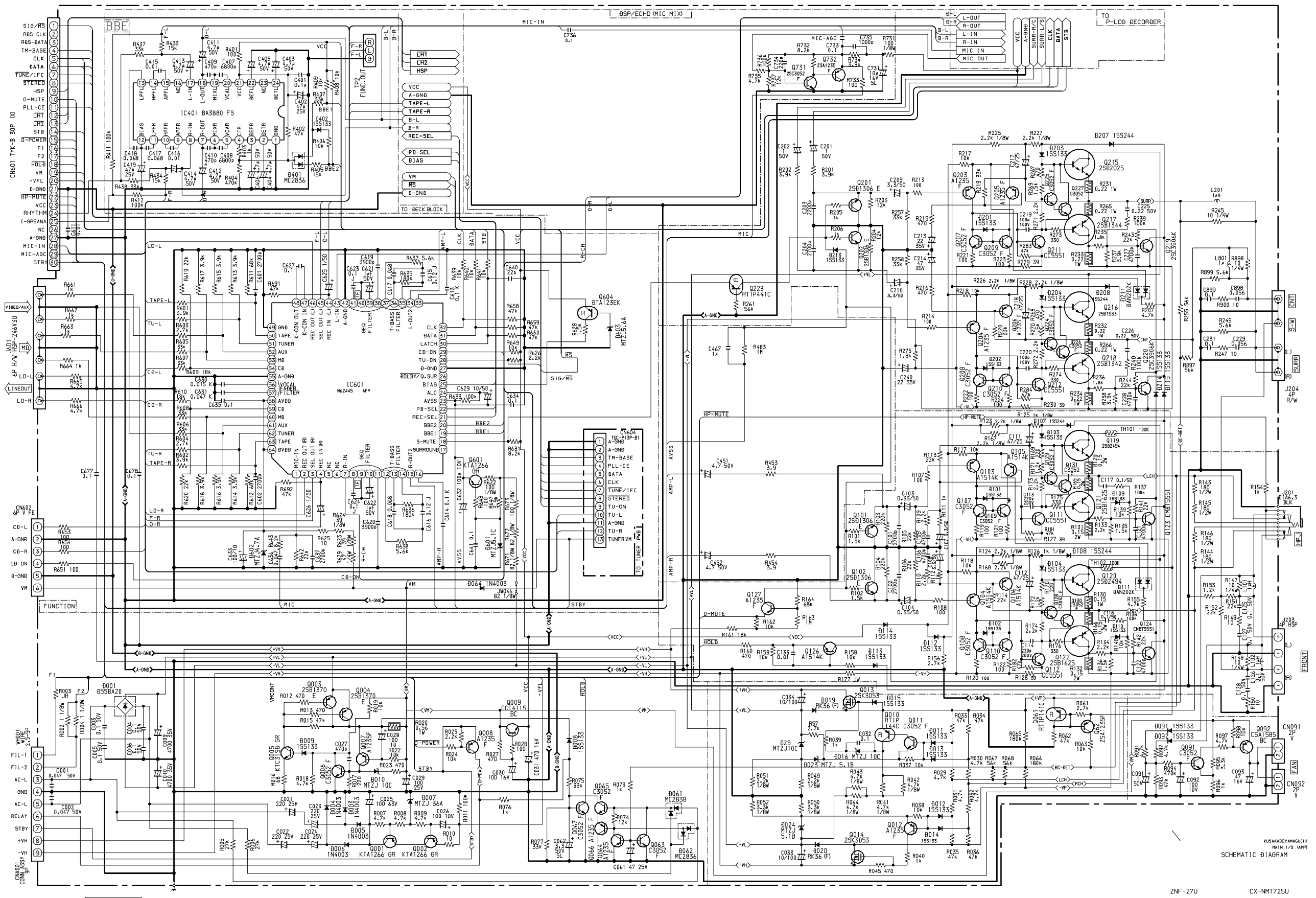

KUSAKABEYAMAGUCHI  
MAIN 1/3 (AMP)  
SCHEMATIC DIAGRAM

SCHEMATIC DIAGRAM – 2 (MAIN 2/3: DECK)

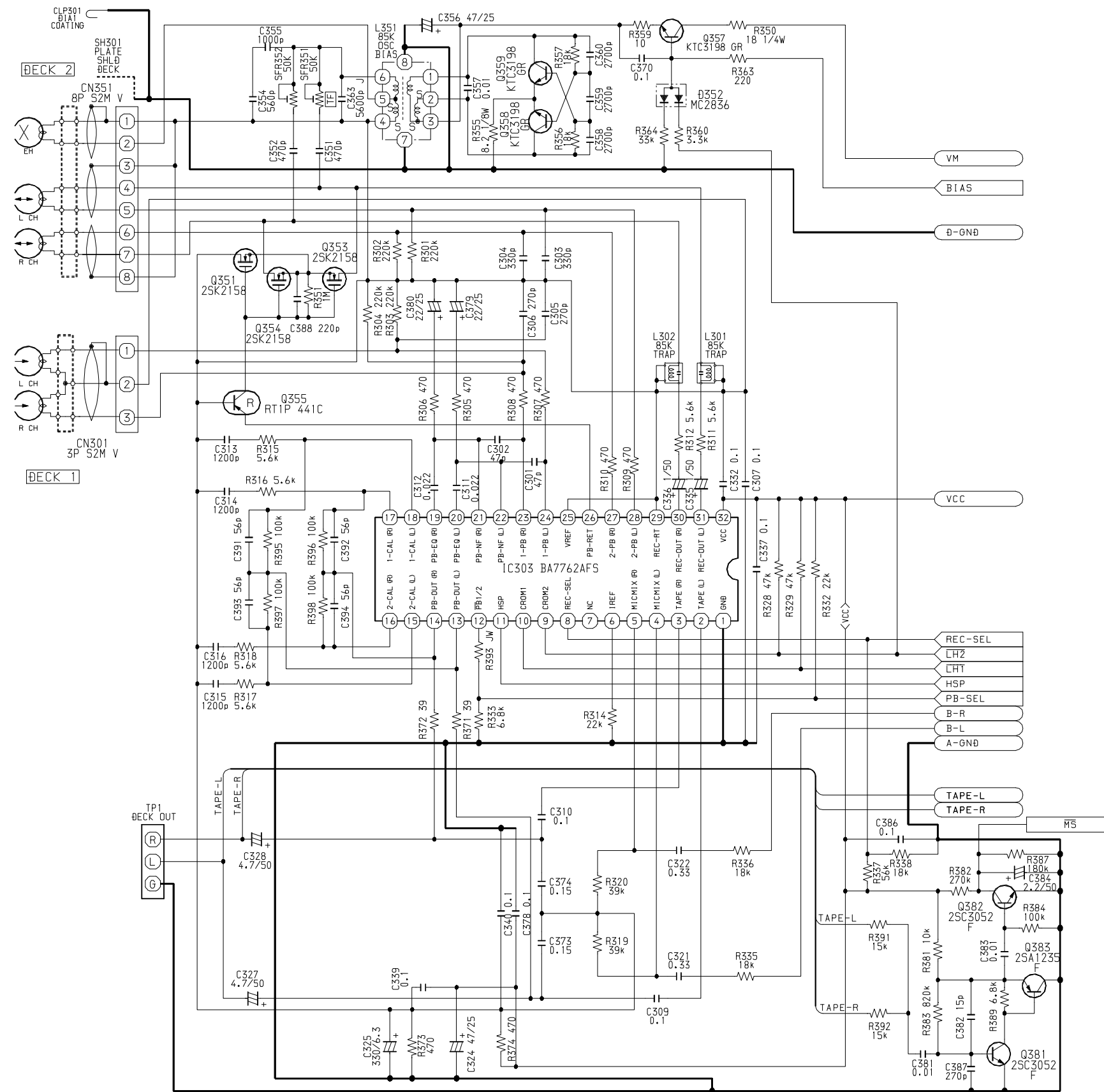

K. KOMATSU  
 MAIN 2/3 (DECK)  
 SCHEMATIC DIAGRAM



SCHEMATIC DIAGRAM - 3 (MAIN 3/3: PROLOGIC)

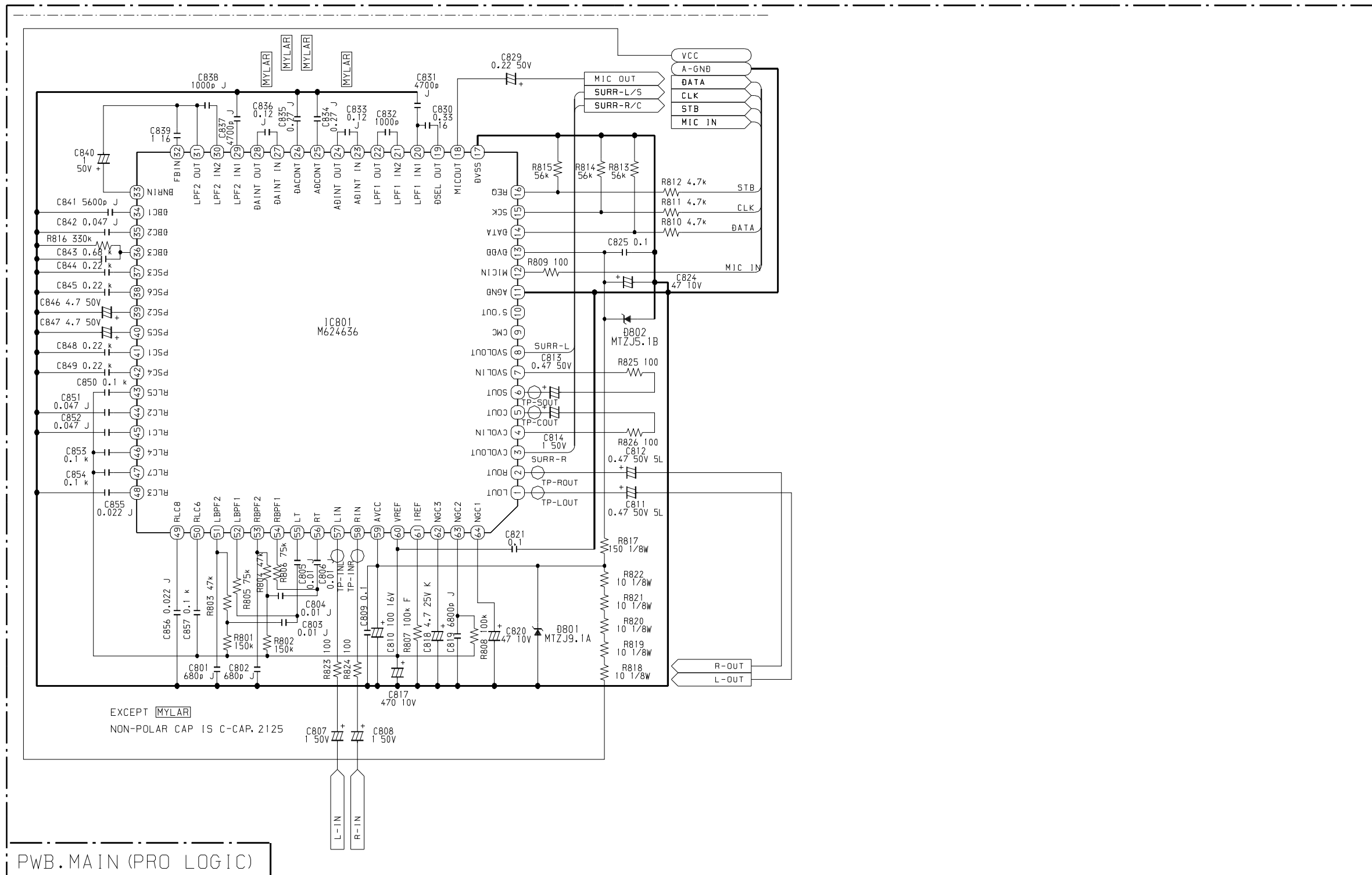

T.UEKI 1,SHIMIZU  
MAIN 3/3 (PRO-LOGIC)  
SCHEMATIC DIAGRAM

SCHEMATIC DIAGRAM - 4 (FRONT)

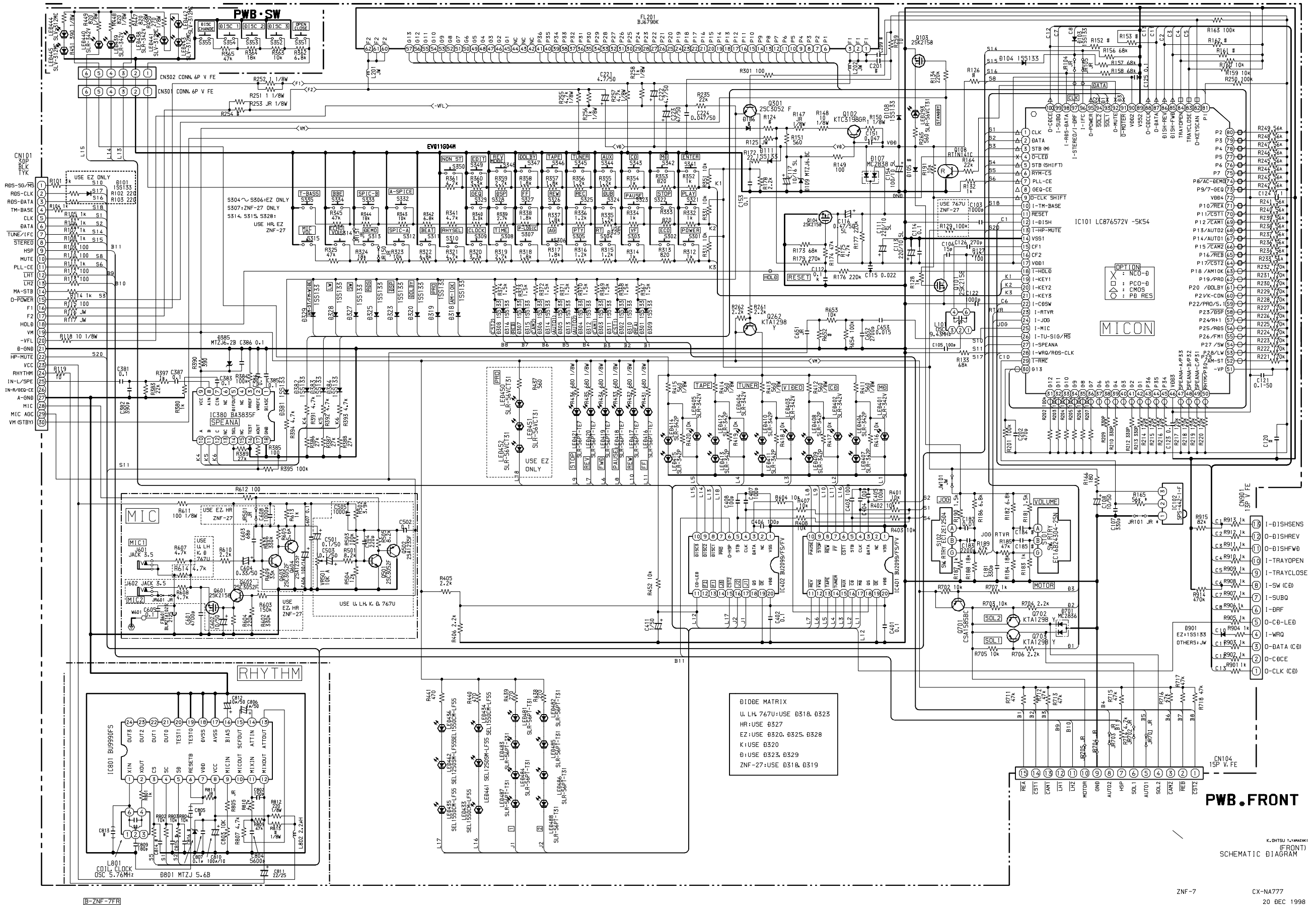

PWB.FRONT

K. OHTSU T. YAMAZAKI  
SCHEMATIC DIAGRAM

SCHEMATIC DIAGRAM – 5 (PT)

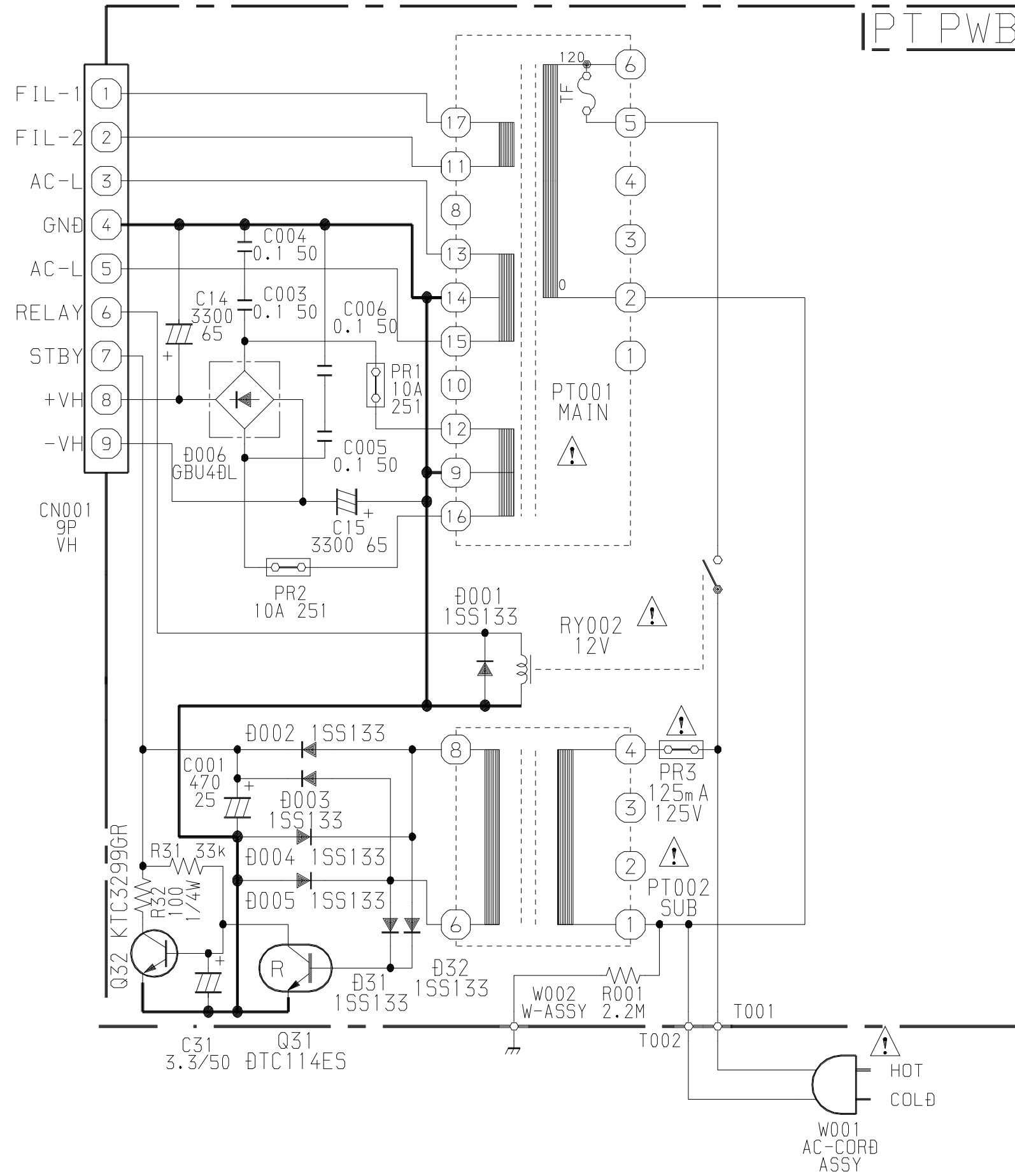

SCHEMATIC DIAGRAM - 6 (TUNER)

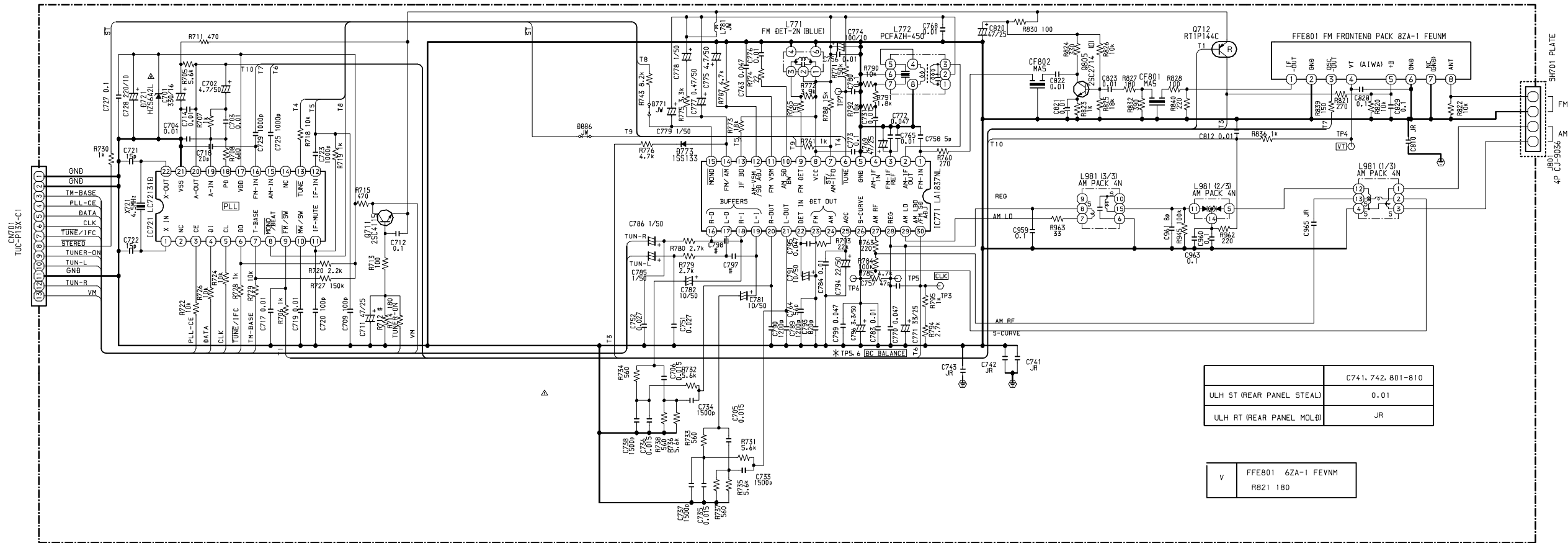

B-ZZA-1-ULH

981021 CHANGE D721  
 M7J5.6A -> HZ56A2L  
 981001 CANCEL C894 JR

94V0 t=1.6  
 FENORIC 130t 8Z 2A1 621 11  
 OC-8Z2A1-02-1

# SCHEMATIC DIAGRAM - 7 (TUNER FRONT END)

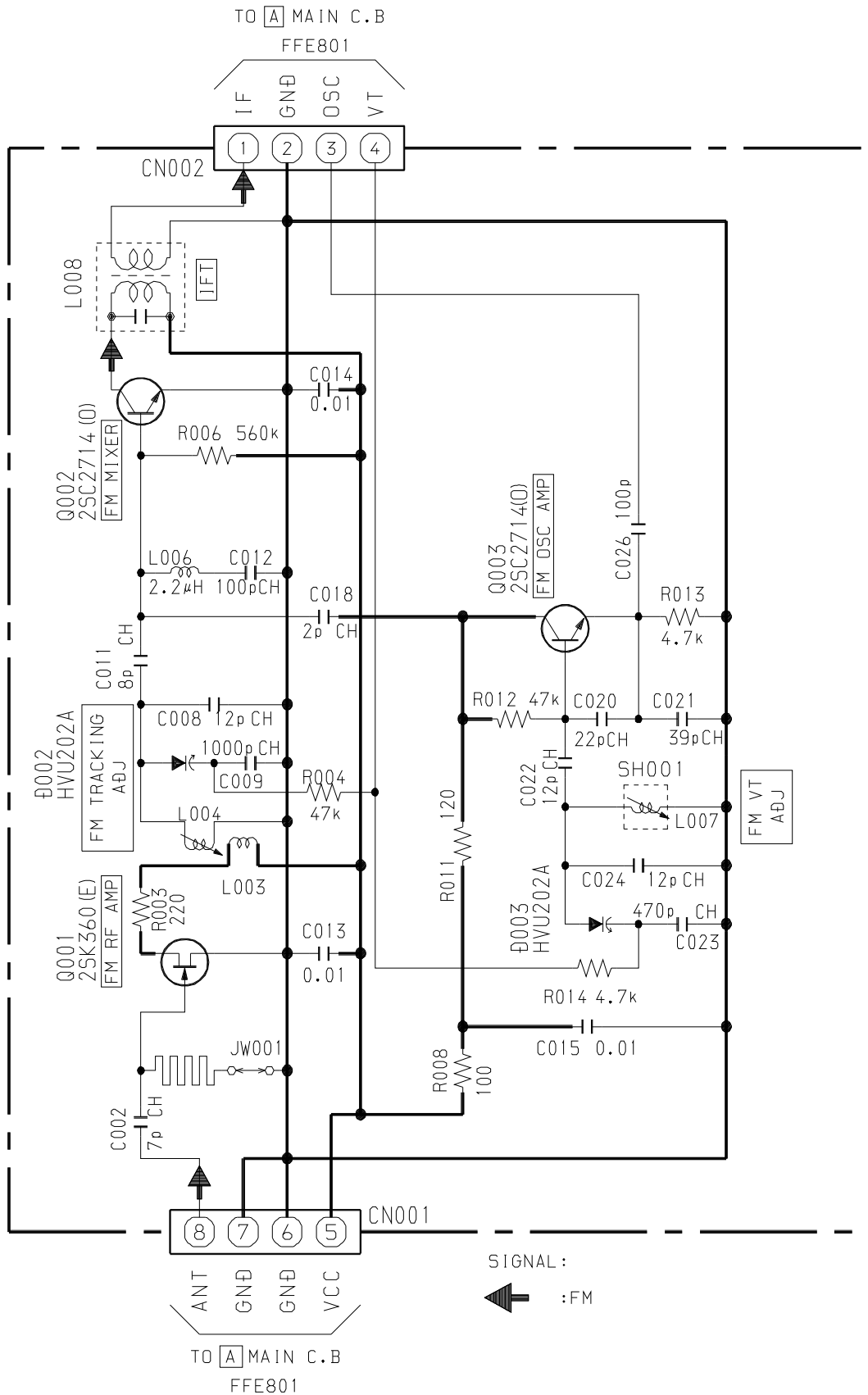

サービス技術ニュース	
番号	連絡内容
G- -	
G- -	
G- -	

**アイワ株式会社**  
**AIWA CO.,LTD.**

9420208

Tokyo Japan

〒110-8710 東京都台東区池之端1-2-11 ☎03(3827)3111 (代表)

Printed in Singapore