

SERVICE MANUAL

CD STEREO SYSTEM

BASIC CD MECHANISM : BZG-2 ZD9GNC2
 BASIC TAPE MECHANISM : CMAT6Z2(1+1)ALPS

SYSTEM	CD CASSEIVER	SPEAKER	REMOTE CONTROLLER
NSX-R14	CX-NR14	SX-NR22	RC-CAS03(VS)

If requiring information about the CD mechanism, see Service Manual of BZG-2 ZD9GNC2, (S/M Code No. 09-023-353-2NA).

TABLE OF CONTENTS -1/1

SPECIFICATIONS	3
PROTECTION OF EYES FROM LASER BEAM DURING SERVICING	4
NOTE ON BEFORE STARTING REPAIR	5, 6
ACCESSORIES PARTS LIST	7
ELECTRICAL PARTS LIST	8 ~ 20
TRANSISTOR ILLUSTRATION	21
SCHEMATIC DIAGRAM -1/5 (MAIN-1/2, AMP SECTION)	22
SCHEMATIC DIAGRAM -2/5 (MAIN-2/2, TUNER SECTION)	23
SCHEMATIC DIAGRAM -3/5 (HP SECTION)	24
WIRING -1/4 (MAIN C.B, HP C.B)	25
SCHEMATIC DIAGRAM -4/5 (FRONT/MIC/DECK SECTION)	26
WIRING -2/4 (FRONT C.B/MIC C.B)	27
WIRING -3/4 (DECK C.B)	28
SCHEMATIC DIAGRAM -5/5 (PT SECTION)	29
WIRING -4/4 (PT C.B)	30
ELECTRICAL ADJUSTMENT	31 ~ 36
CD TEST MODE	37
FL DISPLAY (HUA-13SS09T)	38
IC BLOCK DIAGRAM	39 ~ 40
IC DESCRIPTION	41 ~ 42
MECHANICAL EXPLODED VIEW	43
MECHANICAL PARTS LIST	44
COLOR NAME TABLE	45
TAPE MECHANISM EXPLODED VIEW <CMAT6Z2 (1+1)ALPS>	46
TAPE MECHANISM PARTS LIST <CMAT6Z2 (1+1)ALPS>	47
GENERAL SPEAKER DISASSEMBLY INSTRUCTIONS (FOR REFERENCE)	48
SPEAKER PARTS LIST (SX-NR22)	49
OTHER PARTS LIST	50

SPECIFICATIONS -1/1

MAIN UNIT CX-NR14

TUNER

FM tuning range	87.5 MHz to 108 MHz
FM usable sensitivity (IHF)	13.2 dBf
FM antenna terminal	75 ohms (unbalanced)
AM tuning range	530 kHz to 1710 kHz (10 kHz step) 531 kHz to 1602 kHz (9 kHz step)
AM usable sensitivity	350 μ V/m
AM antenna	Loop antenna

AMPLIFIER

Power output	Rated: 17 W + 17 W (6 ohms, T.H.D. 1 %, 1 kHz) Reference: 20 W + 20 W (6 ohms, T.H.D. 10 %, 1 kHz)
Total harmonic distortion	0.08 % (10 W, 1 kHz, 6 ohms, DIN AUDIO)
Inputs	VIDEO/AUX: 500 mV MIC: 1.0 mV (10 kohms)
Outputs	SPEAKERS: 6 ohms or more PHONES: 32 ohms or more

CASSETTE DECK

Track format	4 tracks, 2 channels stereo
Frequency response	50 Hz - 15 kHz
Recording system	AC bias
Heads	DECK 1: playback x 1 DECK 2: recording/playback x 1, erase x 1

CD PLAYER

Laser	Semiconductor laser ($\lambda = 780$ nm)
D/A converter	1 bit dual
Signal-to-noise ratio	85 dB (1 kHz, 0 dB)
Harmonic distortion	0.05 % (1 kHz, 0 dB)

GENERAL

Power requirements	120 V/220 - 230 V/240 V AC (Switchable), 50 Hz/60 Hz
Power consumption	64 W
Dimensions (W x H x D)	260 x 324 x 315 mm
Weight	5.2 kg

FRONT SPEAKERS SX-NR22

Speaker system	2 way, bass reflex (magnetic shielded)
Speaker units	Woofer: 120 mm cone Tweeter: 60 mm ceramic
Impedance	6 ohms
Dimensions (W x H x D)	210 x 324 x 215 mm
Weight	3.0 kg

- Specifications and external appearance are subject to change without notice.

PROTECTION OF EYES FROM LASER BEAM DURING SERVICING -1/1

This set employs laser. Therefore, be sure to follow carefully the instructions below when servicing.

WARNING!!

WHEN SERVICING, DO NOT APPROACH THE LASER EXIT WITH THE EYE TOO CLOSELY. IN CASE IT IS NECESSARY TO CONFIRM LASER BEAM EMISSION. BE SURE TO OBSERVE FROM A DISTANCE OF MORE THAN 30cm FROM THE SURFACE OF THE OBJECTIVE LENS ON THE OPTICAL PICK-UP BLOCK.

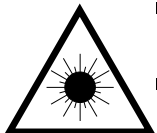

- Caution: Invisible laser radiation when open and interlocks defeated avoid exposure to beam.
- Advarsel: Usynlig laserstråling ved åbning, når sikkerhedsafbrydere er ude af funktion. Undgå udsættelse for stråling.

VAROITUS!

Laiteen Käyttäminen muulla kuin tässä käyttöohjeessa mainitulla tavalla saattaa altistaa käyttäjän turvallisuusluokan 1 ylittävälle näkymättömälle lasersäteilylle.

WARNING!

Om apparaten används på annat sätt än vad som specificeras i denna bruksanvisning, kan användaren utsättas för osynlig laserstråling, som överskrider gränsen för laserklass 1.

CAUTION

Use of controls or adjustments or performance of procedures other than those specified herein may result in hazardous radiation exposure.

ATTENTION

L'utilisation de commandes, réglages ou procédures autres que ceux spécifiés peut entraîner une dangereuse exposition aux radiations.

ADVARSEL

Usynlig laserstråling ved åbning, når sikkerhedsafbrydere er ude af funktion. Undgå udsættelse for stråling.

This Compact Disc player is classified as a CLASS 1 LASER product.

The CLASS 1 LASER PRODUCT label is located on the rear exterior.

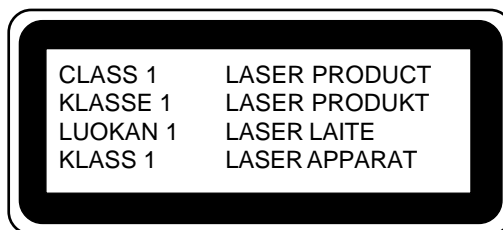

Precaution to replace Optical block

(PXR-104X-BP-0101)

Body or clothes electrostatic potential could ruin laser diode in the optical block. Be sure ground body and workbench, and use care the clothes do not touch the diode.

- 1) After the connection, remove solder shown in right figure.

CD PICK-UP Assy PWB

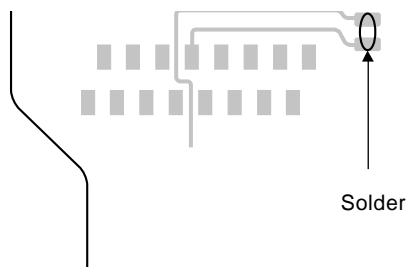

NOTE ON BEFORE STARTING REPAIR -1/2

1. Forced discharge of electrolytic capacitor of power supply block

When repair is going to be attempted in the set that uses relay circuit in the power supply block, electric potential is kept charged across the electrolytic capacitors (C101, 102) even though AC power cord is removed. If repair is attempted in this condition, secondary defect can occur. In order to prevent the secondary trouble, perform the following measures before starting repair work.

Discharge procedure

- ① Remove the AC power cord.
- ② Connect a discharging resistor at an end of lead wire that has clips at both ends. Connect the other end of the lead wire to metal chassis.
- ③ Contact the other end of the discharging resistor to the positive (+) side (+VH) of C101. (For two seconds)
- ④ Contact the same end of the discharging resistor as step ③ to the negative (-) side (-VH) of C102 in the same way. (For two seconds)
- ⑤ Check that voltage across C101 and C102 has decreased to 1 V or less using a multimeter or an oscilloscope.

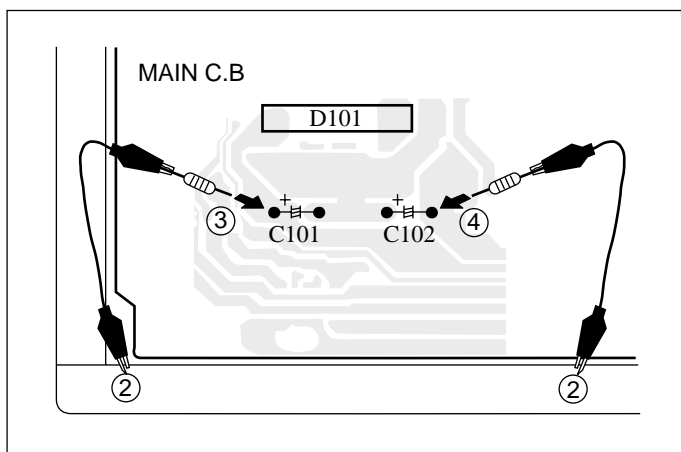

Fig-1

Select a discharging resistor referring to the following table.

Charging voltage (V) (C101, 102)	Discharging resistor (Ω)	Rated power (W)	Parts number
25-48	100	3	87-A00-247-090
49-140	220	5	87-A00-232-090

Note: The reference numbers (C101, C102) of the electrolytic capacitors can change depending on the models. Be sure to check the reference numbers of the charging capacitors on schematic diagram before starting the discharging work.

2. Check items before exchanging the MICROCOMPUTER

Be sure to check the following items before exchanging the MICROCOMPUTER. Exchange the MICROCOMPUTER after confirming that the MICROCOMPUTER is surely defective.

2-1. Regarding the HOLD terminal of the MICROCOMPUTER

When the HOLD terminal (INPUT) of the MICROCOMPUTER is "H", the MICROCOMPUTER is judged to be operating correctly.

When this terminal is "L", the main power cannot be turned on. Therefore, be sure to check the terminal voltage of the HOLD terminal before exchange.

When the MICROCOMPUTER is not defective, the HOLD terminal can also go "L" when the POWER AMPLIFIER has any abnormalities that triggers the abnormality detection circuit on the MAIN C. B. that sets the HOLD terminal to "L".

• Good or no good judgement of the MICROCOMPUTER

- ① Turn on the AC main power.
- ② Confirm that the main power is turned on and the HOLD terminal of the MICROCOMPUTER keeps the "H" level or not.
- ③ When the HOLD terminal is "L" level, the abnormality detection circuit is judged to be working correctly and the MICROCOMPUTER is judged to be good.

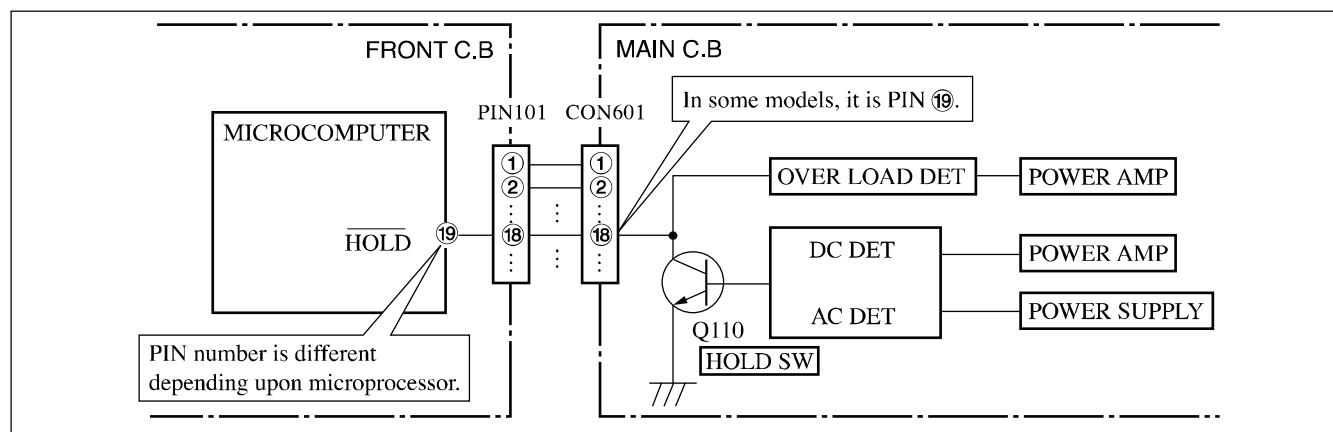

Fig-2-1

NOTE ON BEFORE STARTING REPAIR -2/2

In such a case, check also if the POWER AMPLIFIER circuit or power supply circuit has any abnormalities or not.

2-2. Regarding reset

There are cases that the machine does not work correctly because the MICROCOMPUTER is not reset even though the AC power cord is re-inserted, or the software reset (pressing the STOP key + POWER key) is performed.

When the above described phenomenon occurs, it can lead to wrong judgement as if the MICROCOMPUTER is defective and to exchange the MICROCOMPUTER. In such a case, perform the forced-reset by the following procedure and check good or no good of the MICROCOMPUTER.

- ① Remove the AC power cord.

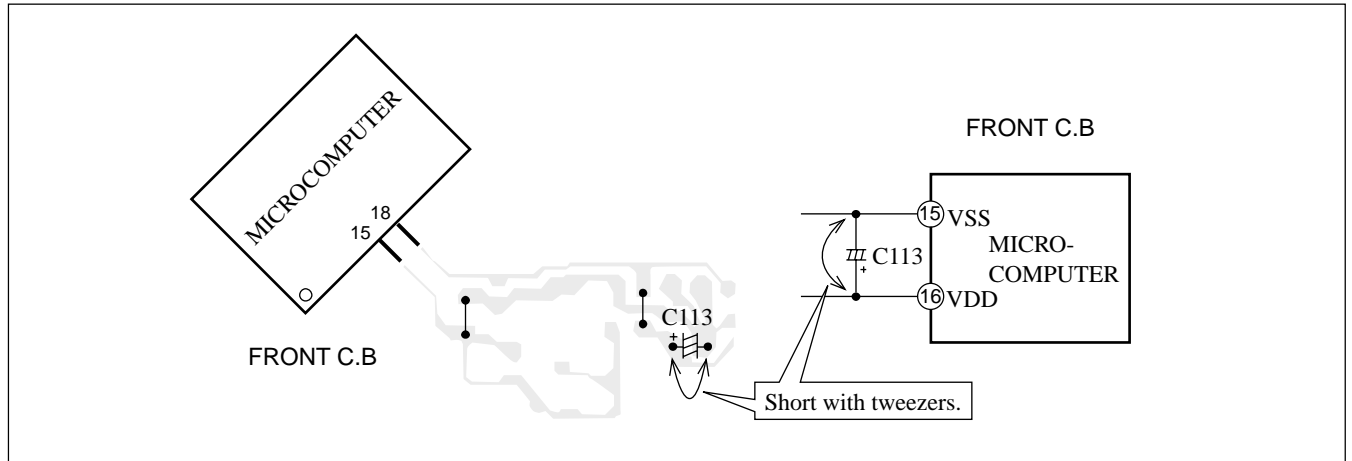

Fig-2-2

- ② Short both ends of the electrolytic capacitor C113 that is connected to VDD of the MICROCOMPUTER with tweezers.
- ③ Connect the AC power cord again. If the MICROCOMPUTER returns to the normal operation, the MICROCOMPUTER is good.

Note: The reference number or MICROCOMPUTER pin number of transistor (Q110) and electrolytic capacitor (C113) can change depending on the models. Be sure to check the reference numbers on schematic diagram before starting the discharging work.

2-3. Confirmation of soldering state of MICROCOMPUTER

Check the soldering state of the MICROCOMPUTER in addition to the above described procedures. Be sure to exchange the MICROCOMPUTER after surely confirming that the trouble is not caused by poor soldering but the MICROCOMPUTER itself.

ACCESSORIES PARTS LIST -1/1

! = Δ SAFETY PARTS

C = Components marked

All components used on this model at the production line are shown in this service manual.

However, please note that not all components will be available as spare parts for after-sales service.

Components marked S and O are designated as spare parts for service and will be stocked at the spare parts centers.

Components marked X and R are not designated as spare parts for after sales service, and will not be stocked at the spare parts centers.

UNIT-NAME	! C	REF-NO	PARTS-NO	PARTS-NAME	SUFFIX&MODEL
					CX-SNR14
					LHSC2
	O	AS1001	8C-NFA-912-010	IB, LH (ESP) BF NSX-R14	a
	O	AS1002	8C-NF8-702-110	RC UNIT, RC-CAS03 (VS)	a
	O	AS1003	87-A92-345-110	ANT, WIRE FM (SEMI-ST)	a
	O	AS1004	87-006-225-110	ANT, LOOP ANT NC2	a
	! O	AS1005	87-A91-017-010	PLUG, CONVERSION JT-0476	a

ELECTRICAL PARTS LIST - 1/13

! = SAFETY PARTS
 C = Components marked

All components used on this model at the production line are shown in this service manual.
 However, please note that not all components will be available as spare parts for after-sales service.
 Components marked S and O are designated as spare parts for service and will be stocked at the spare parts centers.
 Components marked X and R are not designated as spare parts for after sales service, and will not be stocked at the spare parts centers.

UNIT-NAME	! C	REF-NO	PARTS-NO	PARTS-NAME	SUFFIX&MODEL
					CX-SNR14 LHSC2
FRONT	O C	0108	87-010-785-080	C-CAP,U 0.015-25 K B GRM	a
FRONT	O C	0153	87-010-787-080	C-CAP,U 0.022-25 K B GRM	a
FRONT	O C	0154	87-010-246-040	CAP,E 47-35 M 11L SME	a
FRONT	O C	0155	87-010-404-040	CAP,E 4.7-50 M 11L SME	a
FRONT	O C	0156	87-010-404-040	CAP,E 4.7-50 M 11L SME	a
FRONT	O C	0301	87-012-278-080	C-CAP,U 2200P-50 K B GRM	a
FRONT	O C	0351	87-A10-353-080	C-CAP,U 0.22-10 K B	a
FRONT	O C	0361	87-012-274-080	C-CAP,U 1000P-50 K B GRM	a
FRONT	O C	0362	87-012-274-080	C-CAP,U 1000P-50 K B GRM	a
FRONT	O C	0371	87-012-274-080	C-CAP,U 1000P-50 K B GRM	a
FRONT	O C	0372	87-012-274-080	C-CAP,U 1000P-50 K B GRM	a
FRONT	O C	0601	87-010-382-040	CAP,E 22-25 M 11L SME	a
FRONT	O C	0801	87-A10-353-080	C-CAP,U 0.22-10 K B	a
FRONT	O C	0803	87-012-280-080	C-CAP,U 3300P-50 K B GRM	a
FRONT	O C	0804	87-A10-592-080	C-CAP,S 0.015-50 J B	a
FRONT	O C	0806	87-012-273-080	C-CAP,U 820P-50 K B GRM	a
FRONT	O C	0808	87-010-544-040	CAP,E 0.1-50 M 11L SME	a
FRONT	O C	0809	87-010-404-040	CAP,E 4.7-50 M 11L SME	a
FRONT	O C	0810	87-010-759-080	C-CAP,U 0.1-25 Z F CM/CB	a
FRONT	O C	0811	87-A12-052-080	C-CAP,S 0.033-25 J B	a
					CX-SNR14 LHSC2
FRONT	O C	0812	87-012-285-080	C-CAP,U 8200P-50 K B GRM	a
FRONT	O C	0901	87-012-195-080	C-CAP,U 100P-50 J CH GRM	a
FRONT	O C	0902	87-012-195-080	C-CAP,U 100P-50 J CH GRM	a
FRONT	O C	0903	87-012-195-080	C-CAP,U 100P-50 J CH GRM	a
FRONT	O C	0904	87-012-195-080	C-CAP,U 100P-50 J CH GRM	a
FRONT	O C	0905	87-012-195-080	C-CAP,U 100P-50 J CH GRM	a
FRONT	O C	0906	87-012-195-080	C-CAP,U 100P-50 J CH GRM	a
FRONT	O C	0907	87-012-195-080	C-CAP,U 100P-50 J CH GRM	a
FRONT	O C	0908	87-012-195-080	C-CAP,U 100P-50 J CH GRM	a
FRONT	O C	0909	87-012-195-080	C-CAP,U 100P-50 J CH GRM	a
FRONT	O C	0910	87-012-195-080	C-CAP,U 100P-50 J CH GRM	a
FRONT	O C	0911	87-012-274-080	C-CAP,U 1000P-50 K B GRM	a
FRONT	O C	0912	87-010-759-080	C-CAP,U 0.1-25 Z F CM/CB	a
FRONT	O C	0913	87-A10-189-040	CAP,E 220-10 M 5L	a
FRONT	O C	0915	87-010-759-080	C-CAP,U 0.1-25 Z F CM/CB	a
FRONT	O C	0916	87-010-759-080	C-CAP,U 0.1-25 Z F CM/CB	a
FRONT	O C	0917	87-010-759-080	C-CAP,U 0.1-25 Z F CM/CB	a
FRONT	O C	0919	87-012-286-080	C-CAP,U 0.01-25 K B GRM	a
FRONT	O C	0920	87-010-829-080	C-CAP,U 0.047-16 Z F CM/CB	a
FRONT	O C	0921	87-012-282-080	C-CAP,U 4700P-50 K B GRM	a
					CX-SNR14 LHSC2
FRONT	O C	0922	87-012-195-080	C-CAP,U 100P-50 J CH GRM	a
FRONT	O C	0923	87-016-116-080	C-CAP,U 0.015-25 J B CB	a
FRONT	O C	0924	87-016-116-080	C-CAP,U 0.015-25 J B CB	a
FRONT	O C	0925	87-016-116-080	C-CAP,U 0.015-25 J B CB	a
FRONT	O C	0931	87-012-195-080	C-CAP,U 100P-50 J CH GRM	a
FRONT	O C	0932	87-012-195-080	C-CAP,U 100P-50 J CH GRM	a
FRONT	O C	0951	87-012-172-080	C-CAP,U 10P-50 D CH GRM	a
FRONT	O C	0952	87-010-854-080	C-CAP,S 560P-50 J CH CMC	a
FRONT	O C	0953	87-012-349-080	C-CAP,S 1000P-50 J CH GRM	a
FRONT	O C	0961	87-010-391-040	CAP,E 10-35 M 11L SME	a
FRONT	O C	0962	87-012-336-080	C-CAP,U 330P-50 J SL GRM	a
FRONT	O C	0963	87-010-759-080	C-CAP,U 0.1-25 Z F CM/CB	a
FRONT	O CN	0103	87-099-013-010	CONN,11P V BLK 6216	a
FRONT	O CN	0701	87-099-720-010	CONN,30P BLK TYK-B(P)	a
FRONT	O CN	0731	87-099-196-010	CONN,8P V BLK 6216	a
FRONT	S D	0103	87-020-465-080	DIODE,1SS133	a
FRONT	S D	0104	87-020-465-080	DIODE,1SS133	a
FRONT	S D	0301	87-A40-234-080	ZENER,MTZJ5.6A	a
FRONT	S D	0302	87-020-465-080	DIODE,1SS133	a
FRONT	S D	0601	87-A40-269-080	C-DIODE,MC2836	a
					CX-SNR14 LHSC2
FRONT	S D	0801	87-020-465-080	DIODE,1SS133	a
FRONT	S D	0981	87-020-465-080	DIODE,1SS133	a
FRONT	S D	0982	87-020-465-080	DIODE,1SS133	a
FRONT	S D	0991	87-020-465-080	DIODE,1SS133	a
FRONT	O FFC0103	88-911-101-110	FF-CABLE,11P 1.25 100MM	a	
FRONT	O FFC0731	88-908-301-110	FF-CABLE,8P 1.25 300MM	a	
FRONT	O FL 0201	8C-NF9-615-010	FL,HUA-13SS09T	a	
FRONT	S IC 0901	8C-NF9-610-030	C-IC,UPD780226GF-033-3BA	a	
FRONT	S IC 0961	87-A21-831-010	IC,SPS-442-1-F1	a	
FRONT	O L 0951	87-A50-655-010	COIL,CLK 4.19MHZ (TOKO)7KLY	a	
FRONT	S Q 0102	87-A30-076-080	C-TR,2SC3052F	a	
FRONT	S Q 0104	87-A30-538-040	C-TR,SRA2202S	a	
FRONT	S Q 0301	87-A30-494-080	TR,2SA1980G	a	
FRONT	S Q 0302	87-A30-076-080	C-TR,2SC3052F	a	
FRONT	S Q 0303	87-A30-076-080	C-TR,2SC3052F	a	
FRONT	S Q 0601	87-A30-495-080	TR,2SA1981Y	a	
FRONT	S Q 0602	87-A30-495-080	TR,2SA1981Y	a	
FRONT	S Q 0603	87-A30-200-080	TR,2SA1585SR	a	
FRONT	S Q 0801	87-A30-076-080	C-TR,2SC3052F	a	
FRONT	S Q 0802	87-A30-075-080	C-TR,2SA1235F	a	

ELECTRICAL PARTS LIST - 2/13

! = SAFETY PARTS
 C = Components marked

All components used on this model at the production line are shown in this service manual.

However, please note that not all components will be available as spare parts for after-sales service.

Components marked S and O are designated as spare parts for service and will be stocked at the spare parts centers.

Components marked X and R are not designated as spare parts for after sales service, and will not be stocked at the spare parts centers.

UNIT-NAME	! C	REF-NO	PARTS-NO	PARTS-NAME	SUFFIX&MODEL
					CX-SNR14 LHSC2
FRONT	S Q	0803	87-A30-076-080	C-TR,2SC3052F	a
FRONT	S Q	0804	87-A30-076-080	C-TR,2SC3052F	a
FRONT	S Q	0805	87-A30-076-080	C-TR,2SC3052F	a
FRONT	S Q	0901	87-A30-538-040	C-TR,SRA2202S	a
FRONT	O R	0109	88-108-224-080	C-RES,U 220K-1/16W J	a
FRONT	O R	0110	88-108-153-080	C-RES,U 15K-1/16W J	a
FRONT	X R	0111	88-108-333-080	C-RES,U 33K-1/16W J	a
FRONT	O R	0112	88-108-224-080	C-RES,U 220K-1/16W J	a
FRONT	O R	0114	88-108-103-080	C-RES,U 10K-1/16W J	a
FRONT	X R	0115	88-108-183-080	C-RES,U 18K-1/16W J	a
FRONT	X R	0116	88-108-124-080	C-RES,U 120K-1/16W J	a
FRONT	X R	0151	88-100-000-010	PLATING-JW, 0.58 SN95	a
FRONT	X R	0152	88-100-000-010	PLATING-JW, 0.58 SN95	a
FRONT	X R	0153	88-128-821-080	C-RES, 820-1/8W J	a
FRONT	X R	0154	88-128-821-080	C-RES, 820-1/8W J	a
FRONT	O R	0155	88-108-332-080	C-RES,U 3.3K-1/16W J	a
FRONT	O R	0156	88-108-332-080	C-RES,U 3.3K-1/16W J	a
FRONT	X R	0161	88-108-000-080	C-JUMPER,U	a
FRONT	X R	0162	88-108-000-080	C-JUMPER,U	a
FRONT	X R	0163	88-108-000-080	C-JUMPER,U	a
					CX-SNR14 LHSC2
FRONT	X R	0164	88-108-000-080	C-JUMPER,U	a
FRONT	X R	0165	88-108-000-080	C-JUMPER,U	a
FRONT	X R	0166	88-108-000-080	C-JUMPER,U	a
FRONT	X R	0301	88-108-104-080	C-RES,U 100K-1/16W J	a
FRONT	X R	0302	88-108-472-080	C-RES,U 4.7K-1/16W J	a
FRONT	O R	0303	88-108-153-080	C-RES,U 15K-1/16W J	a
FRONT	O R	0304	88-108-102-080	C-RES,U 1K-1/16W J	a
FRONT	X R	0306	88-108-471-080	C-RES,U 470-1/16W J	a
FRONT	O R	0321	88-108-103-080	C-RES,U 10K-1/16W J	a
FRONT	O R	0322	88-108-102-080	C-RES,U 1K-1/16W J	a
FRONT	X R	0323	88-108-821-080	C-RES,U 820-1/16W J	a
FRONT	O R	0324	88-108-102-080	C-RES,U 1K-1/16W J	a
FRONT	X R	0325	88-108-122-080	C-RES,U 1.2K-1/16W J	a
FRONT	X R	0326	88-121-122-080	RES,1.2K-1/8W J	a
FRONT	X R	0327	88-108-182-080	C-RES,U 1.8K-1/16W J	a
FRONT	X R	0328	88-121-182-080	RES,1.8K-1/8W J	a
FRONT	O R	0329	88-108-272-080	C-RES,U 2.7K-1/16W J	a
FRONT	O R	0330	88-108-332-080	C-RES,U 3.3K-1/16W J	a
FRONT	X R	0331	88-121-472-080	RES,4.7K-1/8W J	a
FRONT	X R	0332	88-108-682-080	C-RES,U 6.8K-1/16W J	a
					CX-SNR14 LHSC2
FRONT	O R	0333	88-108-103-080	C-RES,U 10K-1/16W J	a
FRONT	X R	0334	88-108-183-080	C-RES,U 18K-1/16W J	a
FRONT	O R	0335	88-108-473-080	C-RES,U 47K-1/16W J	a
FRONT	O R	0341	88-108-103-080	C-RES,U 10K-1/16W J	a
FRONT	O R	0342	88-108-102-080	C-RES,U 1K-1/16W J	a
FRONT	X R	0343	88-108-821-080	C-RES,U 820-1/16W J	a
FRONT	O R	0344	88-108-102-080	C-RES,U 1K-1/16W J	a
FRONT	X R	0345	88-108-122-080	C-RES,U 1.2K-1/16W J	a
FRONT	X R	0346	88-108-122-080	C-RES,U 1.2K-1/16W J	a
FRONT	X R	0347	88-108-182-080	C-RES,U 1.8K-1/16W J	a
FRONT	X R	0348	88-108-182-080	C-RES,U 1.8K-1/16W J	a
FRONT	O R	0361	88-108-103-080	C-RES,U 10K-1/16W J	a
FRONT	O R	0362	88-108-103-080	C-RES,U 10K-1/16W J	a
FRONT	X R	0363	88-108-100-080	C-RES,U 10-1/16W J	a
FRONT	X R	0364	88-108-100-080	C-RES,U 10-1/16W J	a
FRONT	O R	0371	88-108-103-080	C-RES,U 10K-1/16W J	a
FRONT	O R	0372	88-108-103-080	C-RES,U 10K-1/16W J	a
FRONT	X R	0373	88-108-100-080	C-RES,U 10-1/16W J	a
FRONT	X R	0374	88-108-100-080	C-RES,U 10-1/16W J	a
FRONT	O R	0601	88-108-103-080	C-RES,U 10K-1/16W J	a
					CX-SNR14 LHSC2
FRONT	X R	0602	88-108-222-080	C-RES,U 2.2K-1/16W J	a
FRONT	O R	0603	88-108-103-080	C-RES,U 10K-1/16W J	a
FRONT	X R	0604	88-108-222-080	C-RES,U 2.2K-1/16W J	a
FRONT	O R	0605	88-108-103-080	C-RES,U 10K-1/16W J	a
FRONT	O R	0606	88-108-102-080	C-RES,U 1K-1/16W J	a
FRONT	X R	0607	88-108-000-080	C-JUMPER,U	a
FRONT	O R	0611	88-108-473-080	C-RES,U 47K-1/16W J	a
FRONT	O R	0612	88-108-473-080	C-RES,U 47K-1/16W J	a
FRONT	O R	0613	88-108-473-080	C-RES,U 47K-1/16W J	a
FRONT	O R	0614	88-108-473-080	C-RES,U 47K-1/16W J	a
FRONT	O R	0615	88-108-473-080	C-RES,U 47K-1/16W J	a
FRONT	O R	0617	88-108-473-080	C-RES,U 47K-1/16W J	a
FRONT	O R	0618	88-108-473-080	C-RES,U 47K-1/16W J	a
FRONT	O R	0704	88-108-102-080	C-RES,U 1K-1/16W J	a
FRONT	O R	0705	88-108-102-080	C-RES,U 1K-1/16W J	a
FRONT	O R	0706	88-108-102-080	C-RES,U 1K-1/16W J	a
FRONT	O R	0707	88-108-102-080	C-RES,U 1K-1/16W J	a
FRONT	X R	0708	88-121-102-080	RES,1K-1/8W J	a
FRONT	O R	0709	88-108-101-080	C-RES,U 100-1/16W J	a
FRONT	X R	0710	88-128-101-080	C-RES, 100-1/8W J	a

ELECTRICAL PARTS LIST - 3/13

! = SAFETY PARTS
 C = Components marked

All components used on this model at the production line are shown in this service manual.
 However, please note that not all components will be available as spare parts for after-sales service.
 Components marked S and O are designated as spare parts for service and will be stocked at the spare parts centers.
 Components marked X and R are not designated as spare parts for after sales service, and will not be stocked at the spare parts centers.

UNIT-NAME	! C	REF-NO	PARTS-NO	PARTS-NAME	SUFFIX&MODEL
					CX-SNR14 LHSC2
FRONT	O R	0711	88-108-101-080	C-RES,U 100-1/16W J	a
FRONT	O R	0712	88-108-101-080	C-RES,U 100-1/16W J	a
FRONT	X R	0719	88-108-100-080	C-RES,U 10-1/16W J	a
FRONT	O R	0720	88-108-101-080	C-RES,U 100-1/16W J	a
FRONT	O R	0721	88-108-103-080	C-RES,U 10K-1/16W J	a
FRONT	O R	0730	88-108-102-080	C-RES,U 1K-1/16W J	a
FRONT	O R	0732	88-108-101-080	C-RES,U 100-1/16W J	a
FRONT	O R	0733	88-108-101-080	C-RES,U 100-1/16W J	a
FRONT	O R	0734	88-108-102-080	C-RES,U 1K-1/16W J	a
FRONT	O R	0735	88-108-102-080	C-RES,U 1K-1/16W J	a
FRONT	O R	0740	88-108-102-080	C-RES,U 1K-1/16W J	a
FRONT	O R	0741	88-108-101-080	C-RES,U 100-1/16W J	a
FRONT	O R	0742	88-108-102-080	C-RES,U 1K-1/16W J	a
FRONT	X R	0743	88-108-474-080	C-RES,U 470K-1/16W J	a
FRONT	O R	0744	88-108-823-080	C-RES,U 82K-1/16W J	a
FRONT	X R	0745	88-108-104-080	C-RES,U 100K-1/16W J	a
FRONT	X R	0749	88-108-474-080	C-RES,U 470K-1/16W J	a
FRONT	O R	0803	88-108-102-080	C-RES,U 1K-1/16W J	a
FRONT	O R	0804	88-108-224-080	C-RES,U 220K-1/16W J	a
FRONT	X R	0805	88-108-273-080	C-RES,U 27K-1/16W J	a
					CX-SNR14 LHSC2
FRONT	O R	0806	88-108-562-080	C-RES,U 5.6K-1/16W J	a
FRONT	X R	0807	88-108-000-080	C-JUMPER,U	a
FRONT	X R	0808	88-121-101-080	RES,100-1/8W J	a
FRONT	O R	0809	88-108-102-080	C-RES,U 1K-1/16W J	a
FRONT	X R	0810	88-108-182-080	C-RES,U 1.8K-1/16W J	a
FRONT	O R	0811	88-108-224-080	C-RES,U 220K-1/16W J	a
FRONT	O R	0813	88-108-224-080	C-RES,U 220K-1/16W J	a
FRONT	O R	0815	88-108-272-080	C-RES,U 2.7K-1/16W J	a
FRONT	X R	0816	88-108-104-080	C-RES,U 100K-1/16W J	a
FRONT	O R	0818	88-108-224-080	C-RES,U 220K-1/16W J	a
FRONT	X R	0819	88-108-222-080	C-RES,U 2.2K-1/16W J	a
FRONT	O R	0820	88-108-101-080	C-RES,U 100-1/16W J	a
FRONT	X R	0821	88-108-104-080	C-RES,U 100K-1/16W J	a
FRONT	O R	0822	88-108-224-080	C-RES,U 220K-1/16W J	a
FRONT	X R	0823	88-100-000-010	PLATING-JW, 0.58 SN95	a
FRONT	X R	0824	88-100-000-010	PLATING-JW, 0.58 SN95	a
FRONT	X R	0825	88-100-000-010	PLATING-JW, 0.58 SN95	a
FRONT	X R	0826	88-108-000-080	C-JUMPER,U	a
FRONT	O R	0827	88-108-473-080	C-RES,U 47K-1/16W J	a
FRONT	X R	0901	88-108-104-080	C-RES,U 100K-1/16W J	a
					CX-SNR14 LHSC2
FRONT	X R	0902	88-108-104-080	C-RES,U 100K-1/16W J	a
FRONT	X R	0903	88-108-104-080	C-RES,U 100K-1/16W J	a
FRONT	X R	0904	88-108-104-080	C-RES,U 100K-1/16W J	a
FRONT	X R	0905	88-108-104-080	C-RES,U 100K-1/16W J	a
FRONT	X R	0906	88-108-104-080	C-RES,U 100K-1/16W J	a
FRONT	X R	0907	88-108-104-080	C-RES,U 100K-1/16W J	a
FRONT	X R	0908	88-108-104-080	C-RES,U 100K-1/16W J	a
FRONT	X R	0909	88-108-104-080	C-RES,U 100K-1/16W J	a
FRONT	X R	0910	88-108-104-080	C-RES,U 100K-1/16W J	a
FRONT	X R	0911	88-108-104-080	C-RES,U 100K-1/16W J	a
FRONT	X R	0912	88-108-104-080	C-RES,U 100K-1/16W J	a
FRONT	X R	0913	88-108-104-080	C-RES,U 100K-1/16W J	a
FRONT	X R	0914	88-108-104-080	C-RES,U 100K-1/16W J	a
FRONT	X R	0915	88-108-104-080	C-RES,U 100K-1/16W J	a
FRONT	X R	0916	88-108-104-080	C-RES,U 100K-1/16W J	a
FRONT	X R	0917	88-108-104-080	C-RES,U 100K-1/16W J	a
FRONT	X R	0918	88-108-104-080	C-RES,U 100K-1/16W J	a
FRONT	X R	0919	88-108-104-080	C-RES,U 100K-1/16W J	a
FRONT	X R	0920	88-108-104-080	C-RES,U 100K-1/16W J	a
FRONT	X R	0921	88-108-104-080	C-RES,U 100K-1/16W J	a
					CX-SNR14 LHSC2
FRONT	X R	0922	88-108-104-080	C-RES,U 100K-1/16W J	a
FRONT	X R	0923	88-108-104-080	C-RES,U 100K-1/16W J	a
FRONT	X R	0924	88-108-104-080	C-RES,U 100K-1/16W J	a
FRONT	X R	0925	88-108-104-080	C-RES,U 100K-1/16W J	a
FRONT	X R	0926	88-108-104-080	C-RES,U 100K-1/16W J	a
FRONT	X R	0927	88-108-104-080	C-RES,U 100K-1/16W J	a
FRONT	X R	0928	88-108-104-080	C-RES,U 100K-1/16W J	a
FRONT	X R	0929	88-108-104-080	C-RES,U 100K-1/16W J	a
FRONT	X R	0930	88-108-104-080	C-RES,U 100K-1/16W J	a
FRONT	X R	0931	88-108-104-080	C-RES,U 100K-1/16W J	a
FRONT	X R	0932	88-108-104-080	C-RES,U 100K-1/16W J	a
FRONT	X R	0933	88-121-104-080	RES,100K-1/8W J	a
FRONT	X R	0934	88-108-683-080	C-RES,U 68K-1/16W J	a
FRONT	X R	0935	88-108-683-080	C-RES,U 68K-1/16W J	a
FRONT	X R	0936	88-108-104-080	C-RES,U 100K-1/16W J	a
FRONT	X R	0937	88-128-472-080	C-RES, 4.7K-1/8W J	a
FRONT	X R	0938	88-108-472-080	C-RES,U 4.7K-1/16W J	a
FRONT	X R	0939	88-108-472-080	C-RES,U 4.7K-1/16W J	a
FRONT	X R	0940	88-108-104-080	C-RES,U 100K-1/16W J	a
FRONT	X R	0941	88-108-104-080	C-RES,U 100K-1/16W J	a

ELECTRICAL PARTS LIST - 4/13

! = SAFETY PARTS
 C = Components marked

All components used on this model at the production line are shown in this service manual.
 However, please note that not all components will be available as spare parts for after-sales service.
 Components marked S and O are designated as spare parts for service and will be stocked at the spare parts centers.
 Components marked X and R are not designated as spare parts for after sales service, and will not be stocked at the spare parts centers.

UNIT-NAME	! C	REF-NO	PARTS-NO	PARTS-NAME	SUFFIX&MODEL
					CX-SNR14 LHSC2
FRONT	O R	0942	88-108-103-080	C-RES,U 10K-1/16W J	a
FRONT	X R	0943	88-121-472-080	RES,4.7K-1/8W J	a
FRONT	X R	0946	88-108-000-080	C-JUMPER,U	a
FRONT	X R	0947	88-108-104-080	C-RES,U 100K-1/16W J	a
FRONT	X R	0948	88-121-104-080	RES,100K-1/8W J	a
FRONT	O R	0951	88-108-102-080	C-RES,U 1K-1/16W J	a
FRONT	X R	0955	88-108-104-080	C-RES,U 100K-1/16W J	a
FRONT	X R	0956	88-108-104-080	C-RES,U 100K-1/16W J	a
FRONT	X R	0957	88-108-104-080	C-RES,U 100K-1/16W J	a
FRONT	O R	0958	88-108-103-080	C-RES,U 10K-1/16W J	a
FRONT	O R	0959	88-108-103-080	C-RES,U 10K-1/16W J	a
FRONT	X R	0961	88-121-181-080	RES,180-1/8W J	a
FRONT	O R	0963	88-108-563-080	C-RES,U 56K-1/16W J	a
FRONT	O R	0969	88-108-103-080	C-RES,U 10K-1/16W J	a
FRONT	O R	0981	88-108-103-080	C-RES,U 10K-1/16W J	a
FRONT	O R	0982	88-108-103-080	C-RES,U 10K-1/16W J	a
FRONT	O R	0983	88-108-103-080	C-RES,U 10K-1/16W J	a
FRONT	O R	0984	88-108-103-080	C-RES,U 10K-1/16W J	a
FRONT	X R	0985	88-121-103-080	RES,10K-1/8W J	a
FRONT	X R	0986	88-121-103-080	RES,10K-1/8W J	a
					CX-SNR14 LHSC2
FRONT	O R	0987	88-108-103-080	C-RES,U 10K-1/16W J	a
FRONT	O R	0988	88-108-103-080	C-RES,U 10K-1/16W J	a
FRONT	O R	0989	88-108-103-080	C-RES,U 10K-1/16W J	a
FRONT	O S	0321	87-A90-164-080	SW,TACT SKQAB(N)	a
FRONT	O S	0322	87-A90-164-080	SW,TACT SKQAB(N)	a
FRONT	O S	0323	87-A90-164-080	SW,TACT SKQAB(N)	a
FRONT	O S	0324	87-A90-164-080	SW,TACT SKQAB(N)	a
FRONT	O S	0325	87-A90-164-080	SW,TACT SKQAB(N)	a
FRONT	O S	0326	87-A90-164-080	SW,TACT SKQAB(N)	a
FRONT	O S	0327	87-A90-164-080	SW,TACT SKQAB(N)	a
FRONT	O S	0328	87-A90-164-080	SW,TACT SKQAB(N)	a
FRONT	O S	0329	87-A90-164-080	SW,TACT SKQAB(N)	a
FRONT	O S	0330	87-A90-164-080	SW,TACT SKQAB(N)	a
FRONT	O S	0331	87-A90-164-080	SW,TACT SKQAB(N)	a
FRONT	O S	0332	87-A90-164-080	SW,TACT SKQAB(N)	a
FRONT	O S	0333	87-A90-164-080	SW,TACT SKQAB(N)	a
FRONT	O S	0334	87-A90-164-080	SW,TACT SKQAB(N)	a
FRONT	O S	0335	87-A90-164-080	SW,TACT SKQAB(N)	a
FRONT	O S	0341	87-A90-164-080	SW,TACT SKQAB(N)	a
FRONT	O S	0342	87-A90-164-080	SW,TACT SKQAB(N)	a
					CX-SNR14 LHSC2
FRONT	O S	0343	87-A90-164-080	SW,TACT SKQAB(N)	a
FRONT	O S	0344	87-A90-164-080	SW,TACT SKQAB(N)	a
FRONT	O S	0345	87-A90-164-080	SW,TACT SKQAB(N)	a
FRONT	O S	0346	87-A90-164-080	SW,TACT SKQAB(N)	a
FRONT	O S	0347	87-A90-164-080	SW,TACT SKQAB(N)	a
FRONT	O S	0348	87-A90-164-080	SW,TACT SKQAB(N)	a
FRONT	O S	0361	87-A92-370-010	SW,RTRY RE012307PVB30F	a
FRONT	O S	0371	87-A92-371-010	SW,RTRY RE0123PVB30F	a
HP	O C	0251	87-010-176-080	C-CAP,S 680P-50 J SL C2012	a
HP	O C	0252	87-010-176-080	C-CAP,S 680P-50 J SL C2012	a
HP	O J	0230	87-A60-420-010	JACK,3.5 ST (MSC)	a
HP	X R	0230	88-130-331-080	RES,330-1/4W J	a
HP	X R	0231	88-130-331-080	RES,330-1/4W J	a
HP	X R	0234	88-128-222-080	C-RES, 2.2K-1/8W J	a
HP	X R	0235	88-128-222-080	C-RES, 2.2K-1/8W J	a
HP	O WH	0230	87-A90-459-010	HLDR,WIRE 2.5-5P	a
MAIN	O C	0003	87-010-759-080	C-CAP,U 0.1-25 Z F CM/CB	a
MAIN	O C	0004	87-010-759-080	C-CAP,U 0.1-25 Z F CM/CB	a
MAIN	O C	0005	87-010-759-080	C-CAP,U 0.1-25 Z F CM/CB	a
MAIN	O C	0006	87-010-759-080	C-CAP,U 0.1-25 Z F CM/CB	a
					CX-SNR14 LHSC2
MAIN	O C	0013	87-012-282-080	C-CAP,U 4700P-50 K B GRM	a
MAIN	O C	0014	87-010-260-040	CAP,E 47-25 M 11L SME	a
MAIN	O C	0018	87-012-286-080	C-CAP,U 0.01-25 K B GRM	a
MAIN	O C	0019	87-A12-440-000	CAP,E 3300-35 M 85 IV LELON	a
MAIN	O C	0021	87-A12-440-000	CAP,E 3300-35 M 85 IV LELON	a
MAIN	O C	0022	87-A12-440-000	CAP,E 3300-35 M 85 IV LELON	a
MAIN	O C	0025	87-010-384-080	CAP,E 100-25 M 11L SME	a
MAIN	O C	0026	87-010-384-080	CAP,E 100-25 M 11L SME	a
MAIN	O C	0027	87-010-384-080	CAP,E 100-25 M 11L SME	a
MAIN	O C	0028	87-010-384-080	CAP,E 100-25 M 11L SME	a
MAIN	O C	0030	87-A12-993-080	CAP,E 100-63 M SMG 8X11.5	a
MAIN	O C	0031	87-A12-317-080	C-CAP,U 0.1-50 Z F	a
MAIN	O C	0034	87-010-260-040	CAP,E 47-25 M 11L SME	a
MAIN	O C	0035	87-010-405-080	CAP,E 10-50 M 11L SME	a
MAIN	O C	0036	87-010-260-040	CAP,E 47-25 M 11L SME	a
MAIN	O C	0060	87-010-403-080	CAP,E 3.3-50 M 11L SME	a
MAIN	O C	0061	87-010-260-040	CAP,E 47-25 M 11L SME	a
MAIN	O C	0083	87-010-385-080	CAP,E 220-25 M SME	a
MAIN	O C	0097	87-010-831-080	C-CAP,U 0.1-16 Z F GRM	a
MAIN	O C	0099	87-010-831-080	C-CAP,U 0.1-16 Z F GRM	a

ELECTRICAL PARTS LIST - 5/13

! = SAFETY PARTS
 C = Components marked

All components used on this model at the production line are shown in this service manual.
 However, please note that not all components will be available as spare parts for after-sales service.
 Components marked S and O are designated as spare parts for service and will be stocked at the spare parts centers.
 Components marked X and R are not designated as spare parts for after sales service, and will not be stocked at the spare parts centers.

UNIT-NAME	! C	REF-NO	PARTS-NO	PARTS-NAME	SUFFIX&MODEL
					CX-SNR14 LHSC2
MAIN	O C	0101	87-012-284-080	C-CAP,U 6800P-50 K B GRM	a
MAIN	O C	0102	87-012-284-080	C-CAP,U 6800P-50 K B GRM	a
MAIN	O C	0103	87-010-546-080	CAP,E 0.33-50 M 11L SME	a
MAIN	O C	0104	87-010-546-080	CAP,E 0.33-50 M 11L SME	a
MAIN	O C	0107	87-010-402-080	CAP,E 2.2-50 M 11L SME	a
MAIN	O C	0108	87-010-402-080	CAP,E 2.2-50 M 11L SME	a
MAIN	O C	0111	87-010-383-080	CAP,E 33-25 M 11L SME	a
MAIN	O C	0112	87-010-383-080	CAP,E 33-25 M 11L SME	a
MAIN	O C	0113	87-A12-087-080	CAP,E 1-50 SMG	a
MAIN	O C	0114	87-A12-087-080	CAP,E 1-50 SMG	a
MAIN	O C	0115	87-A10-260-080	C-CAP,U 0.1-16 K B	a
MAIN	O C	0117	87-012-368-080	C-CAP,S 0.1-50 Z F GRM	a
MAIN	O C	0118	87-012-368-080	C-CAP,S 0.1-50 Z F GRM	a
MAIN	O C	0119	87-012-286-080	C-CAP,U 0.01-25 K B GRM	a
MAIN	O C	0120	87-012-286-080	C-CAP,U 0.01-25 K B GRM	a
MAIN	O C	0123	87-010-177-080	C-CAP,S 820P-50 J SL C2012	a
MAIN	O C	0124	87-010-177-080	C-CAP,S 820P-50 J SL C2012	a
MAIN	O C	0125	87-012-188-080	C-CAP,U 47P-50 J CH GRM	a
MAIN	O C	0126	87-012-188-080	C-CAP,U 47P-50 J CH GRM	a
MAIN	O C	0133	87-012-282-080	C-CAP,U 4700P-50 K B GRM	a
					CX-SNR14 LHSC2
MAIN	O C	0140	87-012-278-080	C-CAP,U 2200P-50 K B GRM	a
MAIN	O C	0225	87-012-368-080	C-CAP,S 0.1-50 Z F GRM	a
MAIN	O C	0226	87-012-368-080	C-CAP,S 0.1-50 Z F GRM	a
MAIN	O C	0227	87-012-368-080	C-CAP,S 0.1-50 Z F GRM	a
MAIN	O C	0228	87-012-368-080	C-CAP,S 0.1-50 Z F GRM	a
MAIN	O C	0241	87-010-831-080	C-CAP,U 0.1-16 Z F GRM	a
MAIN	O C	0301	87-012-275-080	C-CAP,U 1200P-50 K B GRM	a
MAIN	O C	0302	87-012-275-080	C-CAP,U 1200P-50 K B GRM	a
MAIN	O C	0303	87-012-275-080	C-CAP,U 1200P-50 K B GRM	a
MAIN	O C	0304	87-012-275-080	C-CAP,U 1200P-50 K B GRM	a
MAIN	O C	0305	87-A10-039-080	C-CAP,U 470P-50 J CH	a
MAIN	O C	0310	87-012-274-080	C-CAP,U 1000P-50 K B GRM	a
MAIN	O C	0363	87-010-759-080	C-CAP,U 0.1-25 Z F CM/CB	a
MAIN	O C	0451	87-010-759-080	C-CAP,U 0.1-25 Z F CM/CB	a
MAIN	O C	0452	87-010-406-080	CAP,E 22-50 M 11L SME	a
MAIN	O C	0453	87-012-279-080	C-CAP,U 2700P-50 K B GRM	a
MAIN	O C	0454	87-012-279-080	C-CAP,U 2700P-50 K B GRM	a
MAIN	O C	0455	87-012-279-080	C-CAP,U 2700P-50 K B GRM	a
MAIN	O C	0456	87-012-286-080	C-CAP,U 0.01-25 K B GRM	a
MAIN	X C	0457	88-708-730-810	CAP,M 5600P-100 J	a
					CX-SNR14 LHSC2
MAIN	O C	0458	87-012-278-080	C-CAP,U 2200P-50 K B GRM	a
MAIN	O C	0459	87-012-271-080	C-CAP,U 560P-50 K B GRM	a
MAIN	O C	0460	87-A12-317-080	C-CAP,U 0.1-50 Z F	a
MAIN	O C	0461	87-012-158-080	C-CAP,S 390P-50 J CH GRM	a
MAIN	O C	0462	87-012-158-080	C-CAP,S 390P-50 J CH GRM	a
MAIN	O C	0463	87-010-759-080	C-CAP,U 0.1-25 Z F CM/CB	a
MAIN	O C	0464	87-012-278-080	C-CAP,U 2200P-50 K B GRM	a
MAIN	O C	0601	87-012-188-080	C-CAP,U 47P-50 J CH GRM	a
MAIN	O C	0602	87-012-188-080	C-CAP,U 47P-50 J CH GRM	a
MAIN	O C	0603	87-010-263-080	CAP,E 100-10 M 11L SME	a
MAIN	O C	0604	87-010-263-080	CAP,E 100-10 M 11L SME	a
MAIN	X C	0605	88-700-740-080	CAP,M 6800P-50 J	a
MAIN	X C	0606	88-700-740-080	CAP,M 6800P-50 J	a
MAIN	O C	0607	87-A10-039-080	C-CAP,U 470P-50 J CH	a
MAIN	O C	0608	87-A10-039-080	C-CAP,U 470P-50 J CH	a
MAIN	O C	0609	87-010-401-080	CAP,E 1-50 M 11L SME	a
MAIN	O C	0610	87-010-401-080	CAP,E 1-50 M 11L SME	a
MAIN	O C	0611	87-A12-790-080	C-CAP,U 560P-50 J CH	a
MAIN	O C	0612	87-A12-790-080	C-CAP,U 560P-50 J CH	a
MAIN	O C	0613	87-012-280-080	C-CAP,U 3300P-50 K B GRM	a
					CX-SNR14 LHSC2
MAIN	O C	0614	87-012-280-080	C-CAP,U 3300P-50 K B GRM	a
MAIN	O C	0615	87-010-545-080	CAP,E 0.22-50 M 11L SME	a
MAIN	O C	0616	87-010-545-080	CAP,E 0.22-50 M 11L SME	a
MAIN	O C	0617	87-010-545-080	CAP,E 0.22-50 M 11L SME	a
MAIN	O C	0618	87-010-545-080	CAP,E 0.22-50 M 11L SME	a
MAIN	O C	0625	87-012-198-080	C-CAP,U 180P-50 J CH GRM	a
MAIN	O C	0626	87-012-198-080	C-CAP,U 180P-50 J CH GRM	a
MAIN	O C	0627	87-012-284-080	C-CAP,U 6800P-50 K B GRM	a
MAIN	O C	0628	87-012-284-080	C-CAP,U 6800P-50 K B GRM	a
MAIN	O C	0629	87-012-286-080	C-CAP,U 0.01-25 K B GRM	a
MAIN	O C	0630	87-012-286-080	C-CAP,U 0.01-25 K B GRM	a
MAIN	O C	0631	87-012-278-080	C-CAP,U 2200P-50 K B GRM	a
MAIN	O C	0632	87-012-278-080	C-CAP,U 2200P-50 K B GRM	a
MAIN	O C	0641	87-010-546-080	CAP,E 0.33-50 M 11L SME	a
MAIN	O C	0642	87-010-546-080	CAP,E 0.33-50 M 11L SME	a
MAIN	O C	0651	87-010-248-080	CAP,E 220-10 M 11L SME	a
MAIN	O C	0652	87-010-260-080	CAP,E 47-25 M 11L SME	a
MAIN	O C	0655	87-010-404-080	CAP,E 4.7-50 M 11L SME	a
MAIN	O C	0656	87-010-784-080	C-CAP,U 0.012-25 K B GRM	a
MAIN	O C	0663	87-010-759-080	C-CAP,U 0.1-25 Z F CM/CB	a

ELECTRICAL PARTS LIST - 6/13

! = SAFETY PARTS
 C = Components marked

All components used on this model at the production line are shown in this service manual.

However, please note that not all components will be available as spare parts for after-sales service.

Components marked S and O are designated as spare parts for service and will be stocked at the spare parts centers.

Components marked X and R are not designated as spare parts for after sales service, and will not be stocked at the spare parts centers.

UNIT-NAME	! C	REF-NO	PARTS-NO	PARTS-NAME	SUFFIX&MODEL
					CX-SNR14 LHSC2
MAIN	O C	0664	87-010-759-080	C-CAP,U 0.1-25 Z F CM/CB	a
MAIN	O C	0665	87-A10-504-080	C-CAP,U 0.047-16 K B	a
MAIN	O C	0666	87-A10-504-080	C-CAP,U 0.047-16 K B	a
MAIN	O C	0677	87-012-286-080	C-CAP,U 0.01-25 K B GRM	a
MAIN	O C	0771	87-010-263-080	CAP,E 100-10 M 11L SME	a
MAIN	O C	0772	87-012-286-080	C-CAP,U 0.01-25 K B GRM	a
MAIN	X C	0781	88-108-000-080	C-JUMPER,U	a
MAIN	O C	0782	87-012-286-080	C-CAP,U 0.01-25 K B GRM	a
MAIN	O C	0783	87-012-286-080	C-CAP,U 0.01-25 K B GRM	a
MAIN	O C	0784	87-012-286-080	C-CAP,U 0.01-25 K B GRM	a
MAIN	O C	0785	87-012-286-080	C-CAP,U 0.01-25 K B GRM	a
MAIN	O C	0786	87-012-286-080	C-CAP,U 0.01-25 K B GRM	a
MAIN	O C	0788	87-012-167-080	C-CAP,U 5P-50 C CH GRM	a
MAIN	O C	0789	87-A13-065-080	C-CAP,U 0.027-25 J B	a
MAIN	O C	0790	87-A13-065-080	C-CAP,U 0.027-25 J B	a
MAIN	O C	0791	87-010-759-080	C-CAP,U 0.1-25 Z F CM/CB	a
MAIN	O C	0792	87-012-286-080	C-CAP,U 0.01-25 K B GRM	a
MAIN	O C	0793	87-010-404-080	CAP,E 4.7-50 M 11L SME	a
MAIN	O C	0795	87-012-286-080	C-CAP,U 0.01-25 K B GRM	a
MAIN	O C	0796	87-012-286-080	C-CAP,U 0.01-25 K B GRM	a
					CX-SNR14 LHSC2
MAIN	O C	0797	87-010-405-080	CAP,E 10-50 M 11L SME	a
MAIN	O C	0798	87-012-286-080	C-CAP,U 0.01-25 K B GRM	a
MAIN	O C	0799	87-010-265-080	CAP,E 33-16 M 11L SME	a
MAIN	O C	0800	87-010-829-080	C-CAP,U 0.047-16 Z F CM/CB	a
MAIN	O C	0801	87-010-403-080	CAP,E 3.3-50 M 11L SME	a
MAIN	O C	0802	87-010-829-080	C-CAP,U 0.047-16 Z F CM/CB	a
MAIN	O C	0803	87-010-787-080	C-CAP,U 0.022-25 K B GRM	a
MAIN	O C	0804	87-010-263-080	CAP,E 100-10 M 11L SME	a
MAIN	O C	0807	87-010-400-080	CAP,E 0.47-50 M 11L SME	a
MAIN	O C	0808	87-010-401-080	CAP,E 1-50 M 11L SME	a
MAIN	O C	0809	87-010-401-080	CAP,E 1-50 M 11L SME	a
MAIN	O C	0810	87-010-759-080	C-CAP,U 0.1-25 Z F CM/CB	a
MAIN	O C	0814	87-012-286-080	C-CAP,U 0.01-25 K B GRM	a
MAIN	O C	0815	87-010-400-080	CAP,E 0.47-50 M 11L SME	a
MAIN	O C	0816	87-010-400-080	CAP,E 0.47-50 M 11L SME	a
MAIN	O C	0821	87-010-405-080	CAP,E 10-50 M 11L SME	a
MAIN	X C	0822	88-108-000-080	C-JUMPER,U	a
MAIN	O C	0823	87-010-177-080	C-CAP,S 820P-50 J SL C2012	a
MAIN	O C	0824	87-010-404-080	CAP,E 4.7-50 M 11L SME	a
MAIN	O C	0825	87-010-596-080	C-CAP,S 0.047-16 K R C2012	a
					CX-SNR14 LHSC2
MAIN	O C	0842	87-012-286-080	C-CAP,U 0.01-25 K B GRM	a
MAIN	X C	0843	88-108-000-080	C-JUMPER,U	a
MAIN	O C	0844	87-012-286-080	C-CAP,U 0.01-25 K B GRM	a
MAIN	X C	0845	88-108-000-080	C-JUMPER,U	a
MAIN	X C	0846	88-108-000-080	C-JUMPER,U	a
MAIN	X C	0847	88-108-000-080	C-JUMPER,U	a
MAIN	X C	0848	88-108-000-080	C-JUMPER,U	a
MAIN	X C	0849	88-108-000-080	C-JUMPER,U	a
MAIN	O C	0850	87-010-260-080	CAP,E 47-25 M 11L SME	a
MAIN	O C	0851	87-012-286-080	C-CAP,U 0.01-25 K B GRM	a
MAIN	O C	0852	87-012-286-080	C-CAP,U 0.01-25 K B GRM	a
MAIN	O C	0853	87-012-286-080	C-CAP,U 0.01-25 K B GRM	a
MAIN	O C	0860	87-012-286-080	C-CAP,U 0.01-25 K B GRM	a
MAIN	O C	0901	87-012-169-080	C-CAP,U 7P-50 D CH GRM	a
MAIN	X C	0906	88-108-000-080	C-JUMPER,U	a
MAIN	O C	0909	87-A10-915-080	C-CAP,U 1000P-25 J CH	a
MAIN	O C	0911	87-012-167-080	C-CAP,U 5P-50 C CH GRM	a
MAIN	O C	0912	87-012-195-080	C-CAP,U 100P-50 J CH GRM	a
MAIN	O C	0914	86-ZA1-616-080	C-CAP,U 0.01-50 K B (MUR)	a
MAIN	O C	0915	86-ZA1-616-080	C-CAP,U 0.01-50 K B (MUR)	a
					CX-SNR14 LHSC2
MAIN	O C	0917	87-012-164-080	C-CAP,U 2P-50 C CH GRM	a
MAIN	O C	0920	87-012-180-080	C-CAP,U 22P-50 J CH GRM	a
MAIN	O C	0921	87-012-186-080	C-CAP,U 39P-50 J CH GRM	a
MAIN	O C	0922	87-012-174-080	C-CAP,U 12P-50 J CH GRM	a
MAIN	O C	0923	87-A10-039-080	C-CAP,U 470P-50 J CH	a
MAIN	O C	0924	87-012-162-080	C-CAP,U 1P-50 C CH GRM	a
MAIN	O C	0926	87-012-195-080	C-CAP,U 100P-50 J CH GRM	a
MAIN	O C	0931	87-A12-319-080	C-CAP,U 0.1-25 K B	a
MAIN	X C	0940	88-108-000-080	C-JUMPER,U	a
MAIN	O C	0959	87-010-759-080	C-CAP,U 0.1-25 Z F CM/CB	a
MAIN	O C	0960	87-010-759-080	C-CAP,U 0.1-25 Z F CM/CB	a
MAIN	O C	0961	87-012-169-080	C-CAP,U 7P-50 D CH GRM	a
MAIN	O C	0962	87-010-401-080	CAP,E 1-50 M 11L SME	a
MAIN	O C	0963	87-A12-319-080	C-CAP,U 0.1-25 K B	a
MAIN	O C	0971	87-010-381-080	CAP,E 330-16 M SME	a
MAIN	O C	0972	87-010-404-080	CAP,E 4.7-50 M 11L SME	a
MAIN	O C	0973	87-012-286-080	C-CAP,U 0.01-25 K B GRM	a
MAIN	O C	0974	87-012-286-080	C-CAP,U 0.01-25 K B GRM	a
MAIN	O C	0979	87-012-195-080	C-CAP,U 100P-50 J CH GRM	a
MAIN	O C	0981	87-010-260-080	CAP,E 47-25 M 11L SME	a

ELECTRICAL PARTS LIST - 7/13

! = SAFETY PARTS
 C = Components marked

All components used on this model at the production line are shown in this service manual.
 However, please note that not all components will be available as spare parts for after-sales service.
 Components marked S and O are designated as spare parts for service and will be stocked at the spare parts centers.
 Components marked X and R are not designated as spare parts for after sales service, and will not be stocked at the spare parts centers.

UNIT-NAME	! C	REF-NO	PARTS-NO	PARTS-NAME	SUFFIX&MODEL
					CX-SNR14 LHSC2
MAIN	O C	0982	87-010-759-080	C-CAP,U 0.1-25 Z F CM/CB	a
MAIN	O C	0983	87-012-286-080	C-CAP,U 0.01-25 K B GRM	a
MAIN	O C	0984	87-012-286-080	C-CAP,U 0.01-25 K B GRM	a
MAIN	O C	0987	87-012-286-080	C-CAP,U 0.01-25 K B GRM	a
MAIN	O C	0988	87-012-286-080	C-CAP,U 0.01-25 K B GRM	a
MAIN	O C	0991	87-012-176-080	C-CAP,U 15P-50 J CH GRM	a
MAIN	O C	0992	87-012-176-080	C-CAP,U 15P-50 J CH GRM	a
MAIN	O C	0993	87-012-274-080	C-CAP,U 1000P-50 K B GRM	a
MAIN	O C	0995	87-012-274-080	C-CAP,U 1000P-50 K B GRM	a
MAIN	O C	0997	87-010-759-080	C-CAP,U 0.1-25 Z F CM/CB	a
MAIN	O C	0998	87-010-260-080	CAP,E 47-25 M 11L SME	a
MAIN	O C	0999	87-A11-155-080	CAP,TC U 0.01-16 Z F	a
MAIN	O CF	0831	87-008-261-010	FLTR,CF SFE10.7MA5	a
MAIN	O CF	0832	87-008-261-010	FLTR,CF SFE10.7MA5	a
MAIN	X CLP0301	87-A60-884-010	PIN,DIA1 COATING-SHS	a	
MAIN	X CLP0304	87-A60-884-010	PIN,DIA1 COATING-SHS	a	
MAIN	O CN	0301	87-A60-620-010	CONN,3P V 2MM JMT	a
MAIN	O CN	0302	87-A60-625-010	CONN,8P V 2MM JMT	a
MAIN	O CN	0601	87-099-719-010	CONN,30P H BLK TYK-B (X)	a
MAIN	O CN	0602	87-099-194-010	CONN,6P V BLK 6216	a
					CX-SNR14 LHSC2
MAIN	O CNA0301	8C-NF9-605-010	CONN ASSY,3P -PB	a	
MAIN	O CNA0302	8C-NF9-606-010	CONN ASSY,8P -RPB	a	
MAIN	S D	0003	87-A40-455-090	DIODE,RL203 GW	a
MAIN	S D	0004	87-A40-455-090	DIODE,RL203 GW	a
MAIN	S D	0005	87-A40-553-080	DIODE,1N4003 LES	a
MAIN	S D	0006	87-A40-553-080	DIODE,1N4003 LES	a
MAIN	S D	0007	87-A40-455-090	DIODE,RL203 GW	a
MAIN	S D	0008	87-A40-455-090	DIODE,RL203 GW	a
MAIN	S D	0011	87-A40-270-080	C-DIODE,MC2838	a
MAIN	S D	0012	87-020-465-080	DIODE,1SS133	a
MAIN	S D	0013	87-A40-345-080	ZENER,MTZJ10C	a
MAIN	S D	0025	87-A40-553-080	DIODE,1N4003 LES	a
MAIN	S D	0026	87-A40-553-080	DIODE,1N4003 LES	a
MAIN	S D	0027	87-A40-553-080	DIODE,1N4003 LES	a
MAIN	S D	0028	87-A40-553-080	DIODE,1N4003 LES	a
MAIN	S D	0029	87-A40-336-080	ZENER,MTZJ27D T-72	a
MAIN	S D	0033	87-020-465-080	DIODE,1SS133	a
MAIN	S D	0060	87-020-465-080	DIODE,1SS133	a
MAIN	S D	0063	87-A40-270-080	C-DIODE,MC2838	a
MAIN	S D	0064	87-A40-269-080	C-DIODE,MC2836	a
					CX-SNR14 LHSC2
MAIN	S D	0092	87-A40-270-080	C-DIODE,MC2838	a
MAIN	S D	0101	87-A40-269-080	C-DIODE,MC2836	a
MAIN	S D	0103	87-020-465-080	DIODE,1SS133	a
MAIN	S D	0104	87-020-465-080	DIODE,1SS133	a
MAIN	S D	0105	87-A40-269-080	C-DIODE,MC2836	a
MAIN	S D	0106	87-A40-269-080	C-DIODE,MC2836	a
MAIN	S D	0107	87-A40-270-080	C-DIODE,MC2838	a
MAIN	S D	0108	87-A40-270-080	C-DIODE,MC2838	a
MAIN	S D	0160	87-A40-270-080	C-DIODE,MC2838	a
MAIN	S D	0280	87-A40-269-080	C-DIODE,MC2836	a
MAIN	S D	0281	87-A40-270-080	C-DIODE,MC2838	a
MAIN	S D	0301	87-A40-269-080	C-DIODE,MC2836	a
MAIN	S D	0661	87-A40-438-080	ZENER,MTZJ4.7A	a
MAIN	S D	0662	87-A40-438-080	ZENER,MTZJ4.7A	a
MAIN	X D	0801	88-100-000-010	PLATING-JW, 0.58 SN95	a
MAIN	S D	0803	87-020-465-080	DIODE,1SS133	a
MAIN	O D	0902	87-A40-916-040	C-VARI-CAP,HVC202A	a
MAIN	O D	0903	87-A40-916-040	C-VARI-CAP,HVC202A	a
MAIN	X D	0944	88-100-000-010	PLATING-JW, 0.58 SN95	a
MAIN	O D	0951	87-A40-799-040	C-VARI-CAP,KV1610S	a
					CX-SNR14 LHSC2
MAIN	S D	0991	87-017-149-080	ZENER,HZS6A2L	a
MAIN	S D	0994	87-020-465-080	DIODE,1SS133	a
MAIN	X FB	0601	88-118-000-080	C-JUMPER,S	a
MAIN	X FB	0602	88-118-000-080	C-JUMPER,S	a
MAIN	X FB	0603	88-100-000-010	PLATING-JW, 0.58 SN95	a
MAIN	O FFC0602	88-906-251-110	FF-CABLE,6P 1.25	a	
MAIN	S IC	0001	87-A21-364-010	IC,NJM7806FA(A)	a
MAIN	S IC	0601	87-A22-236-040	C-IC,BD3881FV	a
MAIN	S IC	0801	87-A22-060-010	IC,LA1845N-A	a
MAIN	S IC	0991	87-A21-928-010	IC,LC72131D-N	a
MAIN	O J	0203	87-A60-238-010	TERMINAL,SP 4P (MSC)	a
MAIN	O J	0602	87-A60-881-010	JACK,PIN 2P MSP 242V05 PBSN	a
MAIN	O J	0831	87-A60-202-010	TERMINAL,ANT 4P MSP-154V-02	a
MAIN	X JR	0835	88-108-561-080	C-RES,U 560-1/16W J	a
MAIN	O L	0201	87-A50-611-010	COIL,1UH K(CS)	a
MAIN	O L	0202	87-A50-611-010	COIL,1UH K(CS)	a
MAIN	O L	0451	87-007-342-010	COIL,OSC 85KHZ BIAS	a
MAIN	O L	0801	87-A50-608-010	COIL,FM DET-N(TOK)	a
MAIN	O L	0802	87-A91-551-010	FLTR,PCFJZH-450 L(TOK)	a
MAIN	O L	0811	87-005-847-080	COIL,2.2UH K CECS	a

ELECTRICAL PARTS LIST - 8/13

! = SAFETY PARTS
 C = Components marked

All components used on this model at the production line are shown in this service manual.

However, please note that not all components will be available as spare parts for after-sales service.

Components marked S and O are designated as spare parts for service and will be stocked at the spare parts centers.

Components marked X and R are not designated as spare parts for after sales service, and will not be stocked at the spare parts centers.

UNIT-NAME	! C	REF-NO	PARTS-NO	PARTS-NAME	SUFFIX&MODEL
					CX-SNR14 LHSC2
MAIN	O L	0832	87-005-847-080	COIL,2.2UH K CECS	a
MAIN	O L	0901	87-A50-110-010	COIL,FM BPF EX	a
MAIN	O L	0903	86-ZA1-624-010	COIL,FM RF-1	a
MAIN	O L	0904	86-ZA1-622-010	COIL,FM ANT/RF-U	a
MAIN	O L	0906	87-005-847-080	COIL,2.2UH K CECS	a
MAIN	O L	0907	86-ZA1-627-010	COIL,FM OSC-U	a
MAIN	O L	0908	88-ZA1-624-010	COIL,FM IFT 7-6.2 (COILS)	a
MAIN	O L	0952	87-A50-752-010	COIL,MW ANT (2B)	a
MAIN	O L	0953	87-A50-753-010	COIL,MW OSC (2B)	a
MAIN	S Q	0001	87-A30-494-080	TR,2SA1980G	a
MAIN	S Q	0002	87-A30-494-080	TR,2SA1980G	a
MAIN	S Q	0003	87-A30-076-080	C-TR,2SC3052F	a
MAIN	S Q	0009	87-A30-494-080	TR,2SA1980G	a
MAIN	S Q	0010	87-A30-076-080	C-TR,2SC3052F	a
MAIN	S Q	0011	89-213-702-010	TR,2SB1370E	a
MAIN	S Q	0012	87-A30-630-080	TR,2SC5343GL	a
MAIN	S Q	0013	87-A30-076-080	C-TR,2SC3052F	a
MAIN	S Q	0014	87-A30-075-080	C-TR,2SA1235F	a
MAIN	S Q	0060	87-A30-076-080	C-TR,2SC3052F	a
MAIN	S Q	0061	87-A30-075-080	C-TR,2SA1235F	a
					CX-SNR14 LHSC2
MAIN	S Q	0062	87-A30-076-080	C-TR,2SC3052F	a
MAIN	S Q	0063	87-A30-075-080	C-TR,2SA1235F	a
MAIN	S Q	0064	87-A30-076-080	C-TR,2SC3052F	a
MAIN	S Q	0101	87-A30-257-080	C-TR,2SD1306E	a
MAIN	S Q	0102	87-A30-257-080	C-TR,2SD1306E	a
MAIN	S Q	0103	87-A30-075-080	C-TR,2SA1235F	a
MAIN	S Q	0104	87-A30-075-080	C-TR,2SA1235F	a
MAIN	S Q	0105	87-A30-075-080	C-TR,2SA1235F	a
MAIN	S Q	0106	87-A30-075-080	C-TR,2SA1235F	a
MAIN	S Q	0107	87-A30-076-080	C-TR,2SC3052F	a
MAIN	S Q	0108	87-A30-076-080	C-TR,2SC3052F	a
MAIN	S Q	0109	87-A30-076-080	C-TR,2SC3052F	a
MAIN	S Q	0110	87-A30-076-080	C-TR,2SC3052F	a
MAIN	S Q	0111	87-A30-630-080	TR,2SC5343GL	a
MAIN	S Q	0112	87-A30-630-080	TR,2SC5343GL	a
MAIN	S Q	0113	87-A30-076-080	C-TR,2SC3052F	a
MAIN	S Q	0114	87-A30-076-080	C-TR,2SC3052F	a
MAIN	S Q	0117	87-A30-255-010	TR,2SB1342	a
MAIN	S Q	0118	87-A30-255-010	TR,2SB1342	a
MAIN	S Q	0119	87-A30-256-010	TR,2SD1933	a
					CX-SNR14 LHSC2
MAIN	S Q	0120	87-A30-256-010	TR,2SD1933	a
MAIN	S Q	0123	87-A30-075-080	C-TR,2SA1235F	a
MAIN	S Q	0124	87-A30-075-080	C-TR,2SA1235F	a
MAIN	S Q	0126	87-A30-075-080	C-TR,2SA1235F	a
MAIN	S Q	0130	87-A30-076-080	C-TR,2SC3052F	a
MAIN	S Q	0131	87-A30-075-080	C-TR,2SA1235F	a
MAIN	S Q	0280	87-A30-538-040	C-TR,SRA2202S	a
MAIN	S Q	0281	87-A30-075-080	C-TR,2SA1235F	a
MAIN	S Q	0301	87-A30-091-080	FET,2SJ460	a
MAIN	S Q	0302	87-A30-091-080	FET,2SJ460	a
MAIN	S Q	0303	87-A30-090-080	FET,2SK2541	a
MAIN	S Q	0304	87-A30-090-080	FET,2SK2541	a
MAIN	S Q	0305	87-A30-091-080	FET,2SJ460	a
MAIN	S Q	0306	87-A30-091-080	FET,2SJ460	a
MAIN	S Q	0307	87-A30-090-080	FET,2SK2541	a
MAIN	S Q	0308	87-A30-090-080	FET,2SK2541	a
MAIN	S Q	0309	87-A30-090-080	FET,2SK2541	a
MAIN	S Q	0451	87-A30-630-080	TR,2SC5343GL	a
MAIN	S Q	0452	87-A30-076-080	C-TR,2SC3052F	a
MAIN	S Q	0453	89-333-317-880	TR,2SC3331 (T/U)	a
					CX-SNR14 LHSC2
MAIN	S Q	0454	89-333-317-880	TR,2SC3331 (T/U)	a
MAIN	S Q	0601	87-A30-538-040	C-TR,SRA2202S	a
MAIN	S Q	0651	87-A30-087-080	C-FET,2SK2158	a
MAIN	S Q	0652	87-A30-087-080	C-FET,2SK2158	a
MAIN	S Q	0653	87-A30-076-080	C-TR,2SC3052F	a
MAIN	S Q	0835	87-A30-521-080	C-TR,2SC5345SF/S (O)	a
MAIN	S Q	0836	87-A30-677-040	C-TR,SRA2207S	a
MAIN	S Q	0901	89-503-602-080	C-FET,2SK360E	a
MAIN	S Q	0902	87-A30-664-080	C-TR,2SC2620B	a
MAIN	S Q	0904	87-A30-699-040	C-TR,2SC5477-T22	a
MAIN	S Q	0981	87-A30-494-080	TR,2SA1980G	a
MAIN	S Q	0982	87-A30-076-080	C-TR,2SC3052F	a
MAIN	S Q	0983	87-A30-076-080	C-TR,2SC3052F	a
MAIN	X R	0001	88-100-000-010	PLATING-JW, 0.58 SN95	a
MAIN	X R	0005	88-100-000-010	PLATING-JW, 0.58 SN95	a
MAIN	O R	0009	88-108-223-080	C-RES,U 22K-1/16W J	a
MAIN	O R	0010	88-108-223-080	C-RES,U 22K-1/16W J	a
MAIN	X R	0011	88-108-472-080	C-RES,U 4.7K-1/16W J	a
MAIN	X R	0012	88-118-472-080	C-RES,S 4.7K-1/10W J	a
MAIN	X R	0013	88-118-472-080	C-RES,S 4.7K-1/10W J	a

ELECTRICAL PARTS LIST - 9/13

! = Δ SAFETY PARTS
 C = Components marked

All components used on this model at the production line are shown in this service manual.
 However, please note that not all components will be available as spare parts for after-sales service.
 Components marked S and O are designated as spare parts for service and will be stocked at the spare parts centers.
 Components marked X and R are not designated as spare parts for after sales service, and will not be stocked at the spare parts centers.

UNIT-NAME	! C	REF-NO	PARTS-NO	PARTS-NAME	SUFFIX&MODEL
					CX-SNR14 LHSC2
MAIN	X R	0014	88-118-100-080	C-RES,S 10-1/10W J	a
MAIN	X R	0015	88-108-104-080	C-RES,U 100K-1/16W J	a
MAIN	X R	0016	88-108-104-080	C-RES,U 100K-1/16W J	a
MAIN	X R	0017	88-108-104-080	C-RES,U 100K-1/16W J	a
MAIN	X R	0018	88-108-104-080	C-RES,U 100K-1/16W J	a
MAIN	X R	0019	88-108-104-080	C-RES,U 100K-1/16W J	a
MAIN	X R	0020	88-129-000-080	C-JUMPER, 3216	a
MAIN	X R	0024	88-118-103-080	C-RES,S 10K-1/10W J	a
MAIN	X R	0026	88-108-472-080	C-RES,U 4.7K-1/16W J	a
MAIN	X R	0027	88-118-000-080	C-JUMPER,S	a
MAIN	X R	0028	88-108-221-080	C-RES,U 220-1/16W J	a
MAIN	O R	0029	88-108-223-080	C-RES,U 22K-1/16W J	a
MAIN	X R	0031	88-108-154-080	C-RES,U 150K-1/16W J	a
MAIN	X R	0032	88-108-472-080	C-RES,U 4.7K-1/16W J	a
MAIN	X R	0035	88-118-123-080	C-RES,S 12K-1/10W J	a
MAIN	X R	0036	88-130-182-080	RES,1.8K-1/4W J	a
MAIN	X R	0042	88-121-331-080	RES,330-1/8W J	a
MAIN	X R	0043	88-121-331-080	RES,330-1/8W J	a
MAIN	X R	0044	88-121-331-080	RES,330-1/8W J	a
MAIN	X R	0045	88-121-331-080	RES,330-1/8W J	a
					CX-SNR14 LHSC2
MAIN	X R	0046	88-121-821-080	RES,820-1/8W J	a
MAIN	O R	0052	88-108-103-080	C-RES,U 10K-1/16W J	a
MAIN	X R	0056	88-108-680-080	C-RES,U 68-1/16W J	a
MAIN	X R	0057	88-108-472-080	C-RES,U 4.7K-1/16W J	a
MAIN	O R	0058	88-108-103-080	C-RES,U 10K-1/16W J	a
MAIN	X R	0059	88-108-221-080	C-RES,U 220-1/16W J	a
MAIN	X R	0060	88-108-471-080	C-RES,U 470-1/16W J	a
MAIN	O R	0061	88-108-103-080	C-RES,U 10K-1/16W J	a
MAIN	O R	0065	88-108-123-080	C-RES,U 12K-1/16W J	a
MAIN	X R	0066	88-108-104-080	C-RES,U 100K-1/16W J	a
MAIN	O R	0076	88-108-103-080	C-RES,U 10K-1/16W J	a
MAIN	O R	0081	88-108-101-080	C-RES,U 100-1/16W J	a
MAIN	X R	0091	88-130-181-080	RES,180-1/4W J	a
MAIN	X R	0092	88-130-181-080	RES,180-1/4W J	a
MAIN	X R	0103	88-108-472-080	C-RES,U 4.7K-1/16W J	a
MAIN	X R	0104	88-108-472-080	C-RES,U 4.7K-1/16W J	a
MAIN	X R	0105	88-108-273-080	C-RES,U 27K-1/16W J	a
MAIN	X R	0106	88-108-273-080	C-RES,U 27K-1/16W J	a
MAIN	O R	0107	88-108-101-080	C-RES,U 100-1/16W J	a
MAIN	O R	0108	88-108-101-080	C-RES,U 100-1/16W J	a
					CX-SNR14 LHSC2
MAIN	X R	0111	88-118-102-080	C-RES,S 1K-1/10W J	a
MAIN	X R	0112	88-118-102-080	C-RES,S 1K-1/10W J	a
MAIN	X R	0113	88-118-273-080	C-RES,S 27K-1/10W J	a
MAIN	X R	0114	88-118-273-080	C-RES,S 27K-1/10W J	a
MAIN	X R	0117	88-128-103-080	C-RES, 10K-1/8W J	a
MAIN	X R	0118	88-128-103-080	C-RES, 10K-1/8W J	a
MAIN	X R	0119	88-118-101-080	C-RES,S 100-1/10W J	a
MAIN	X R	0120	88-118-101-080	C-RES,S 100-1/10W J	a
MAIN	X R	0121	88-118-101-080	C-RES,S 100-1/10W J	a
MAIN	X R	0122	88-118-101-080	C-RES,S 100-1/10W J	a
MAIN	X R	0123	88-128-102-080	C-RES, 1K-1/8W J	a
MAIN	X R	0124	88-128-102-080	C-RES, 1K-1/8W J	a
MAIN	X R	0125	88-128-102-080	C-RES, 1K-1/8W J	a
MAIN	X R	0126	88-128-102-080	C-RES, 1K-1/8W J	a
MAIN	X R	0127	88-118-390-080	C-RES,S 39-1/10W J	a
MAIN	X R	0128	88-118-390-080	C-RES,S 39-1/10W J	a
MAIN	X R	0129	88-128-109-080	C-RES, 1-1/8W J	a
MAIN	X R	0130	88-128-109-080	C-RES, 1-1/8W J	a
MAIN	X R	0131	88-128-109-080	C-RES, 1-1/8W J	a
MAIN	X R	0132	88-128-109-080	C-RES, 1-1/8W J	a
					CX-SNR14 LHSC2
MAIN	X R	0133	88-108-122-080	C-RES,U 1.2K-1/16W J	a
MAIN	X R	0134	88-108-122-080	C-RES,U 1.2K-1/16W J	a
MAIN	X R	0135	88-108-182-080	C-RES,U 1.8K-1/16W J	a
MAIN	X R	0136	88-108-182-080	C-RES,U 1.8K-1/16W J	a
MAIN	O R	0137	88-108-101-080	C-RES,U 100-1/16W J	a
MAIN	O R	0138	88-108-101-080	C-RES,U 100-1/16W J	a
MAIN	O R	0139	88-108-562-080	C-RES,U 5.6K-1/16W J	a
MAIN	O R	0140	88-108-562-080	C-RES,U 5.6K-1/16W J	a
MAIN	X R	0141	88-118-102-080	C-RES,S 1K-1/10W J	a
MAIN	X R	0142	88-118-102-080	C-RES,S 1K-1/10W J	a
MAIN	X R	0143	88-128-109-080	C-RES, 1-1/8W J	a
MAIN	X R	0144	88-128-109-080	C-RES, 1-1/8W J	a
MAIN	X R	0145	88-128-109-080	C-RES, 1-1/8W J	a
MAIN	X R	0146	88-128-109-080	C-RES, 1-1/8W J	a
MAIN	X R	0157	88-108-472-080	C-RES,U 4.7K-1/16W J	a
MAIN	X R	0158	88-108-472-080	C-RES,U 4.7K-1/16W J	a
MAIN	O R	0159	88-108-103-080	C-RES,U 10K-1/16W J	a
MAIN	X R	0160	88-118-103-080	C-RES,S 10K-1/10W J	a
MAIN	X R	0165	88-118-152-080	C-RES,S 1.5K-1/10W J	a
MAIN	X R	0166	88-118-152-080	C-RES,S 1.5K-1/10W J	a

ELECTRICAL PARTS LIST - 10/13

! = SAFETY PARTS
 C = Components marked

All components used on this model at the production line are shown in this service manual.

However, please note that not all components will be available as spare parts for after-sales service.

Components marked S and O are designated as spare parts for service and will be stocked at the spare parts centers.

Components marked X and R are not designated as spare parts for after sales service, and will not be stocked at the spare parts centers.

UNIT-NAME	! C	REF-NO	PARTS-NO	PARTS-NAME	SUFFIX&MODEL
					CX-SNR14 LHSC2
MAIN	O R	0167	88-108-103-080	C-RES,U 10K-1/16W J	a
MAIN	X R	0168	88-118-473-080	C-RES,S 47K-1/10W J	a
MAIN	X R	0171	88-118-222-080	C-RES,S 2.2K-1/10W J	a
MAIN	X R	0172	88-118-222-080	C-RES,S 2.2K-1/10W J	a
MAIN	X R	0173	88-118-182-080	C-RES,S 1.8K-1/10W J	a
MAIN	X R	0174	88-118-182-080	C-RES,S 1.8K-1/10W J	a
MAIN	X R	0175	88-118-331-080	C-RES,S 330-1/10W J	a
MAIN	X R	0176	88-118-331-080	C-RES,S 330-1/10W J	a
MAIN	X R	0178	88-118-103-080	C-RES,S 10K-1/10W J	a
MAIN	O R	0179	88-108-473-080	C-RES,U 47K-1/16W J	a
MAIN	O R	0180	88-108-473-080	C-RES,U 47K-1/16W J	a
MAIN	X R	0181	88-108-392-080	C-RES,U 3.9K-1/16W J	a
MAIN	X R	0182	88-108-392-080	C-RES,U 3.9K-1/16W J	a
MAIN	X R	0183	88-108-222-080	C-RES,U 2.2K-1/16W J	a
MAIN	X R	0184	88-108-222-080	C-RES,U 2.2K-1/16W J	a
MAIN	X R	0185	88-108-683-080	C-RES,U 68K-1/16W J	a
MAIN	X R	0186	88-108-105-080	C-RES,U 1M-1/16W J	a
MAIN	X R	0187	88-108-000-080	C-JUMPER,U	a
MAIN	X R	0247	88-130-100-080	RES,10-1/4W J	a
MAIN	X R	0248	88-130-100-080	RES,10-1/4W J	a
					CX-SNR14 LHSC2
MAIN	X R	0249	88-128-100-080	C-RES, 10-1/8W J	a
MAIN	X R	0250	88-128-100-080	C-RES, 10-1/8W J	a
MAIN	X R	0280	88-118-473-080	C-RES,S 47K-1/10W J	a
MAIN	X R	0281	88-108-222-080	C-RES,U 2.2K-1/16W J	a
MAIN	X R	0282	88-118-103-080	C-RES,S 10K-1/10W J	a
MAIN	X R	0283	88-118-224-080	C-RES,S 220K-1/10W J	a
MAIN	X R	0284	88-118-224-080	C-RES,S 220K-1/10W J	a
MAIN	X R	0285	88-118-333-080	C-RES,S 33K-1/10W J	a
MAIN	X R	0286	88-118-473-080	C-RES,S 47K-1/10W J	a
MAIN	X R	0287	88-118-473-080	C-RES,S 47K-1/10W J	a
MAIN	X R	0301	88-108-393-080	C-RES,U 39K-1/16W J	a
MAIN	X R	0302	88-108-393-080	C-RES,U 39K-1/16W J	a
MAIN	O R	0303	88-108-823-080	C-RES,U 82K-1/16W J	a
MAIN	O R	0304	88-108-823-080	C-RES,U 82K-1/16W J	a
MAIN	O R	0305	88-108-224-080	C-RES,U 220K-1/16W J	a
MAIN	X R	0451	88-108-222-080	C-RES,U 2.2K-1/16W J	a
MAIN	X R	0453	88-108-472-080	C-RES,U 4.7K-1/16W J	a
MAIN	X R	0454	88-121-829-080	RES,8.2-1/8W J	a
MAIN	X R	0455	88-108-183-080	C-RES,U 18K-1/16W J	a
MAIN	X R	0456	88-108-183-080	C-RES,U 18K-1/16W J	a
					CX-SNR14 LHSC2
MAIN	X R	0457	88-108-104-080	C-RES,U 100K-1/16W J	a
MAIN	O R	0458	88-108-563-080	C-RES,U 56K-1/16W J	a
MAIN	X R	0459	88-108-472-080	C-RES,U 4.7K-1/16W J	a
MAIN	X R	0469	88-108-150-080	C-RES,U 15-1/16W J	a
MAIN	X R	0601	88-108-820-080	C-RES,U 82-1/16W J	a
MAIN	X R	0602	88-108-820-080	C-RES,U 82-1/16W J	a
MAIN	X R	0603	88-108-394-080	C-RES,U 390K-1/16W J	a
MAIN	X R	0604	88-108-394-080	C-RES,U 390K-1/16W J	a
MAIN	X R	0605	88-108-122-080	C-RES,U 1.2K-1/16W J	a
MAIN	X R	0606	88-108-122-080	C-RES,U 1.2K-1/16W J	a
MAIN	X R	0607	88-108-183-080	C-RES,U 18K-1/16W J	a
MAIN	X R	0608	88-108-183-080	C-RES,U 18K-1/16W J	a
MAIN	X R	0609	88-108-472-080	C-RES,U 4.7K-1/16W J	a
MAIN	X R	0610	88-108-472-080	C-RES,U 4.7K-1/16W J	a
MAIN	X R	0613	88-108-273-080	C-RES,U 27K-1/16W J	a
MAIN	X R	0614	88-108-273-080	C-RES,U 27K-1/16W J	a
MAIN	O R	0615	88-108-153-080	C-RES,U 15K-1/16W J	a
MAIN	O R	0616	88-108-153-080	C-RES,U 15K-1/16W J	a
MAIN	O R	0617	88-108-153-080	C-RES,U 15K-1/16W J	a
MAIN	O R	0619	88-108-153-080	C-RES,U 15K-1/16W J	a
					CX-SNR14 LHSC2
MAIN	O R	0621	88-108-332-080	C-RES,U 3.3K-1/16W J	a
MAIN	O R	0622	88-108-332-080	C-RES,U 3.3K-1/16W J	a
MAIN	X R	0623	88-108-182-080	C-RES,U 1.8K-1/16W J	a
MAIN	X R	0624	88-108-182-080	C-RES,U 1.8K-1/16W J	a
MAIN	X R	0625	88-108-682-080	C-RES,U 6.8K-1/16W J	a
MAIN	X R	0626	88-108-682-080	C-RES,U 6.8K-1/16W J	a
MAIN	X R	0627	88-108-222-080	C-RES,U 2.2K-1/16W J	a
MAIN	X R	0628	88-108-222-080	C-RES,U 2.2K-1/16W J	a
MAIN	O R	0629	88-108-103-080	C-RES,U 10K-1/16W J	a
MAIN	O R	0630	88-108-103-080	C-RES,U 10K-1/16W J	a
MAIN	X R	0631	88-108-222-080	C-RES,U 2.2K-1/16W J	a
MAIN	X R	0632	88-108-222-080	C-RES,U 2.2K-1/16W J	a
MAIN	X R	0633	88-108-222-080	C-RES,U 2.2K-1/16W J	a
MAIN	X R	0634	88-108-222-080	C-RES,U 2.2K-1/16W J	a
MAIN	O R	0635	88-108-102-080	C-RES,U 1K-1/16W J	a
MAIN	O R	0636	88-108-102-080	C-RES,U 1K-1/16W J	a
MAIN	O R	0637	88-108-102-080	C-RES,U 1K-1/16W J	a
MAIN	O R	0638	88-108-102-080	C-RES,U 1K-1/16W J	a
MAIN	X R	0639	88-108-183-080	C-RES,U 18K-1/16W J	a
MAIN	X R	0640	88-108-183-080	C-RES,U 18K-1/16W J	a

ELECTRICAL PARTS LIST - 11/13

! = Δ SAFETY PARTS
 C = Components marked

All components used on this model at the production line are shown in this service manual.

However, please note that not all components will be available as spare parts for after-sales service.

Components marked S and O are designated as spare parts for service and will be stocked at the spare parts centers.

Components marked X and R are not designated as spare parts for after sales service, and will not be stocked at the spare parts centers.

UNIT-NAME	! C	REF-NO	PARTS-NO	PARTS-NAME	SUFFIX&MODEL
					CX-SNR14 LHSC2
MAIN	X R	0641	88-121-223-080	RES,22K-1/8W J	a
MAIN	X R	0642	88-108-222-080	C-RES,U 2.2K-1/16W J	a
MAIN	X R	0643	88-108-104-080	C-RES,U 100K-1/16W J	a
MAIN	X R	0644	88-108-104-080	C-RES,U 100K-1/16W J	a
MAIN	O R	0649	88-108-332-080	C-RES,U 3.3K-1/16W J	a
MAIN	O R	0650	88-108-332-080	C-RES,U 3.3K-1/16W J	a
MAIN	O R	0651	88-108-101-080	C-RES,U 100-1/16W J	a
MAIN	O R	0652	88-108-101-080	C-RES,U 100-1/16W J	a
MAIN	X R	0656	88-121-394-080	RES,390K-1/8W J	a
MAIN	X R	0657	88-108-274-080	C-RES,U 270K-1/16W J	a
MAIN	X R	0658	88-108-274-080	C-RES,U 270K-1/16W J	a
MAIN	X R	0659	88-108-394-080	C-RES,U 390K-1/16W J	a
MAIN	X R	0660	88-108-274-080	C-RES,U 270K-1/16W J	a
MAIN	X R	0661	88-108-392-080	C-RES,U 3.9K-1/16W J	a
MAIN	X R	0662	88-108-392-080	C-RES,U 3.9K-1/16W J	a
MAIN	O R	0669	88-108-223-080	C-RES,U 22K-1/16W J	a
MAIN	O R	0670	88-108-223-080	C-RES,U 22K-1/16W J	a
MAIN	O R	0672	88-108-223-080	C-RES,U 22K-1/16W J	a
MAIN	X R	0673	88-108-392-080	C-RES,U 3.9K-1/16W J	a
MAIN	X R	0674	88-108-273-080	C-RES,U 27K-1/16W J	a
					CX-SNR14 LHSC2
MAIN	O R	0676	88-108-563-080	C-RES,U 56K-1/16W J	a
MAIN	O R	0677	88-108-223-080	C-RES,U 22K-1/16W J	a
MAIN	O R	0678	88-108-223-080	C-RES,U 22K-1/16W J	a
MAIN	X R	0789	88-108-273-080	C-RES,U 27K-1/16W J	a
MAIN	O R	0790	87-012-286-080	C-CAP,U 0.01-25 K B GRM	a
MAIN	O R	0791	88-108-102-080	C-RES,U 1K-1/16W J	a
MAIN	X R	0793	88-108-000-080	C-JUMPER,U	a
MAIN	X R	0795	88-108-000-080	C-JUMPER,U	a
MAIN	O R	0801	88-108-103-080	C-RES,U 10K-1/16W J	a
MAIN	O R	0802	88-108-223-080	C-RES,U 22K-1/16W J	a
MAIN	X R	0803	88-128-183-080	C-RES, 18K-1/8W J	a
MAIN	X R	0804	88-108-000-080	C-JUMPER,U	a
MAIN	O R	0805	88-108-332-080	C-RES,U 3.3K-1/16W J	a
MAIN	X R	0806	88-108-682-080	C-RES,U 6.8K-1/16W J	a
MAIN	O R	0809	88-108-102-080	C-RES,U 1K-1/16W J	a
MAIN	O R	0810	88-108-102-080	C-RES,U 1K-1/16W J	a
MAIN	X R	0811	88-108-000-080	C-JUMPER,U	a
MAIN	X R	0812	88-108-000-080	C-JUMPER,U	a
MAIN	O R	0813	88-108-224-080	C-RES,U 220K-1/16W J	a
MAIN	X R	0814	88-108-105-080	C-RES,U 1M-1/16W J	a
					CX-SNR14 LHSC2
MAIN	X R	0815	88-121-682-080	RES,6.8K-1/8W J	a
MAIN	O R	0818	88-108-103-080	C-RES,U 10K-1/16W J	a
MAIN	X R	0821	88-108-000-080	C-JUMPER,U	a
MAIN	X R	0823	88-108-333-080	C-RES,U 33K-1/16W J	a
MAIN	O R	0826	88-108-223-080	C-RES,U 22K-1/16W J	a
MAIN	X R	0832	88-108-391-080	C-RES,U 390-1/16W J	a
MAIN	X R	0840	88-108-221-080	C-RES,U 220-1/16W J	a
MAIN	O R	0850	88-108-103-080	C-RES,U 10K-1/16W J	a
MAIN	X R	0851	88-108-000-080	C-JUMPER,U	a
MAIN	O R	0852	88-108-103-080	C-RES,U 10K-1/16W J	a
MAIN	O R	0853	88-108-102-080	C-RES,U 1K-1/16W J	a
MAIN	X R	0854	88-108-331-080	C-RES,U 330-1/16W J	a
MAIN	X R	0855	88-108-183-080	C-RES,U 18K-1/16W J	a
MAIN	O R	0856	88-108-103-080	C-RES,U 10K-1/16W J	a
MAIN	X R	0857	88-108-181-080	C-RES,U 180-1/16W J	a
MAIN	O R	0858	88-108-101-080	C-RES,U 100-1/16W J	a
MAIN	O R	0860	88-108-101-080	C-RES,U 100-1/16W J	a
MAIN	X R	0903	88-108-221-080	C-RES,U 220-1/16W J	a
MAIN	O R	0904	88-108-473-080	C-RES,U 47K-1/16W J	a
MAIN	O R	0905	88-108-102-080	C-RES,U 1K-1/16W J	a
					CX-SNR14 LHSC2
MAIN	X R	0906	88-108-564-080	C-RES,U 560K-1/16W J	a
MAIN	X R	0908	88-108-000-080	C-JUMPER,U	a
MAIN	X R	0911	88-108-121-080	C-RES,U 120-1/16W J	a
MAIN	O R	0912	88-108-473-080	C-RES,U 47K-1/16W J	a
MAIN	X R	0913	88-108-472-080	C-RES,U 4.7K-1/16W J	a
MAIN	X R	0914	88-108-472-080	C-RES,U 4.7K-1/16W J	a
MAIN	X R	0918	88-108-000-080	C-JUMPER,U	a
MAIN	X R	0945	88-108-104-080	C-RES,U 100K-1/16W J	a
MAIN	X R	0962	88-121-102-080	RES,1K-1/8W J	a
MAIN	X R	0963	88-108-330-080	C-RES,U 33-1/16W J	a
MAIN	O R	0968	88-108-822-080	C-RES,U 8.2K-1/16W J	a
MAIN	O R	0975	88-108-562-080	C-RES,U 5.6K-1/16W J	a
MAIN	O R	0976	88-108-102-080	C-RES,U 1K-1/16W J	a
MAIN	O R	0977	88-108-102-080	C-RES,U 1K-1/16W J	a
MAIN	X R	0978	88-108-681-080	C-RES,U 680-1/16W J	a
MAIN	O R	0979	88-108-123-080	C-RES,U 12K-1/16W J	a
MAIN	X R	0980	88-108-684-080	C-RES,U 680K-1/16W J	a
MAIN	X R	0981	88-121-471-080	RES,470-1/8W J	a
MAIN	X R	0982	88-108-682-080	C-RES,U 6.8K-1/16W J	a
MAIN	X R	0983	88-108-392-080	C-RES,U 3.9K-1/16W J	a

ELECTRICAL PARTS LIST - 12/13

! = SAFETY PARTS
 C = Components marked

All components used on this model at the production line are shown in this service manual.

However, please note that not all components will be available as spare parts for after-sales service.

Components marked S and O are designated as spare parts for service and will be stocked at the spare parts centers.

Components marked X and R are not designated as spare parts for after sales service, and will not be stocked at the spare parts centers.

UNIT-NAME	! C	REF-NO	PARTS-NO	PARTS-NAME	SUFFIX&MODEL
					CX-SNR14 LHSC2
MAIN	O R	0984	88-108-102-080	C-RES,U 1K-1/16W J	a
MAIN	X R	0985	88-121-471-080	RES,470-1/8W J	a
MAIN	X R	0986	88-121-221-080	RES,220-1/8W J	a
MAIN	X R	0987	88-121-472-080	RES,4.7K-1/8W J	a
MAIN	O R	0988	88-108-103-080	C-RES,U 10K-1/16W J	a
MAIN	X R	0989	88-121-102-080	RES,1K-1/8W J	a
MAIN	O R	0990	88-108-563-080	C-RES,U 56K-1/16W J	a
MAIN	O R	0991	87-012-195-080	C-CAP,U 100P-50 J CH GRM	a
MAIN	O R	0992	88-108-103-080	C-RES,U 10K-1/16W J	a
MAIN	O R	0993	87-012-195-080	C-CAP,U 100P-50 J CH GRM	a
MAIN	O R	0994	88-108-103-080	C-RES,U 10K-1/16W J	a
MAIN	O R	0995	87-012-195-080	C-CAP,U 100P-50 J CH GRM	a
MAIN	O R	0996	88-108-103-080	C-RES,U 10K-1/16W J	a
MAIN	X R	0997	88-108-154-080	C-RES,U 150K-1/16W J	a
MAIN	O R	0998	88-108-102-080	C-RES,U 1K-1/16W J	a
MAIN	O R	0999	88-108-103-080	C-RES,U 10K-1/16W J	a
MAIN	O RY	0001	87-A91-339-010	RELAY,AC DC12V G5PA-2	a
MAIN	O SFR	0451	87-024-435-080	SFR,33K H RH063MC	a
MAIN	O SFR	0452	87-024-435-080	SFR,33K H RH063MC	a
MAIN	X SH	0901	8B-ZA3-619-010	SHLD-CASE,BZA-3 EZ	a
					CX-SNR14 LHSC2
MAIN	O TH	0101	87-A91-042-080	C-THMS,100K 55001	a
MAIN	O TH	0102	87-A91-042-080	C-THMS,100K 55001	a
MAIN	O W	0099	8C-NFA-605-010	F-CABLE,5P 2.5 480MM	a
MAIN	O W	0101	8B-NF1-640-010	F-CABLE,5P 2.5 250MM	a
MAIN	O WH	0001	87-A90-459-010	HLDR,WIRE 2.5-5P	a
MAIN	O WH	0101	87-A90-459-010	HLDR,WIRE 2.5-5P	a
MAIN	O X	0992	87-A70-306-010	VIB,XTAL 4.500MHZ CSA-309ST	a
MIC	O C	0401	87-012-282-080	C-CAP,U 4700P-50 K B GRM	a
MIC	O C	0402	87-010-112-040	CAP,E 100-16 M 11L SME	a
MIC	O C	0403	87-010-545-040	CAP,E 0.22-50 M 11L SME	a
MIC	O C	0404	87-012-191-080	C-CAP,U 68P-50 J CH GRM	a
MIC	O C	0405	87-010-545-040	CAP,E 0.22-50 M 11L SME	a
MIC	O C	0406	87-010-545-040	CAP,E 0.22-50 M 11L SME	a
MIC	O C	0407	87-010-405-040	CAP,E 10-50 M 11L SME	a
MIC	O C	0408	87-012-195-080	C-CAP,U 100P-50 J CH GRM	a
MIC	O C	0409	87-010-265-040	CAP,E 33-16 M 11L SME	a
MIC	O C	0410	87-010-829-080	C-CAP,U 0.047-16 Z F CM/CB	a
MIC	O C	0413	87-010-177-080	C-CAP,S 820P-50 J SL C2012	a
MIC	O FB	0401	87-008-372-080	FLTR,EMI BL01 RN1	a
MIC	O J	0401	87-A61-243-010	JACK,6.3 BLK MONO W/SW V MSC	a
					CX-SNR14 LHSC2
MIC	S Q	0401	87-A30-076-080	C-TR,2SC3052F	a
MIC	S Q	0402	87-A30-075-080	C-TR,2SA1235F	a
MIC	S Q	0403	87-A30-076-080	C-TR,2SC3052F	a
MIC	S Q	0404	87-A30-075-080	C-TR,2SA1235F	a
MIC	S Q	0405	87-A30-087-080	C-FET,2SK2158	a
MIC	S Q	0406	87-A30-076-080	C-TR,2SC3052F	a
MIC	X R	0401	88-108-472-080	C-RES,U 4.7K-1/16W J	a
MIC	X R	0402	88-108-104-080	C-RES,U 100K-1/16W J	a
MIC	X R	0403	88-128-101-080	C-RES, 100-1/8W J	a
MIC	X R	0404	88-108-222-080	C-RES,U 2.2K-1/16W J	a
MIC	O R	0405	88-108-102-080	C-RES,U 1K-1/16W J	a
MIC	X R	0406	88-108-334-080	C-RES,U 330K-1/16W J	a
MIC	X R	0407	88-108-333-080	C-RES,U 33K-1/16W J	a
MIC	O R	0408	88-108-562-080	C-RES,U 5.6K-1/16W J	a
MIC	O R	0409	88-108-101-080	C-RES,U 100-1/16W J	a
MIC	O R	0410	88-108-153-080	C-RES,U 15K-1/16W J	a
MIC	X R	0411	88-108-561-080	C-RES,U 560-1/16W J	a
MIC	X R	0412	88-108-274-080	C-RES,U 270K-1/16W J	a
MIC	O R	0413	88-108-223-080	C-RES,U 22K-1/16W J	a
MIC	O R	0414	88-108-102-080	C-RES,U 1K-1/16W J	a
					CX-SNR14 LHSC2
MIC	X R	0415	88-108-000-080	C-JUMPER,U	a
MIC	O R	0416	88-108-224-080	C-RES,U 220K-1/16W J	a
MIC	X R	0417	88-108-104-080	C-RES,U 100K-1/16W J	a
MIC	X R	0418	88-108-154-080	C-RES,U 150K-1/16W J	a
MIC	O VR	0401	86-NFA-607-010	VR,RTRY 10K15AX1 1 V XV0121PVN	a
PT	O C	0091	87-010-831-080	C-CAP,U 0.1-16 Z F GRM	a
PT	! S F	0090	87-A91-213-010	FUSE,1.25A 250V T 50T	a
PT	! O FC	0091	87-A90-160-080	FUSE CLAMP,FC 51F	a
PT	! O FC	0092	87-A90-160-080	FUSE CLAMP,FC 51F	a
PT	! O PT	0001	8C-NHA-601-010	PT,HR/HT CNH-A	a
PT	! O S	0001	87-A90-165-010	SW,SL 1-2-3 SWS2301	a
PT	! O T	0001	87-A60-317-010	TERMINAL, 1P MSC	a
PT	! O T	0002	87-A60-317-010	TERMINAL, 1P MSC	a
PT	O WH	0002	87-A90-459-010	HLDR,WIRE 2.5-5P	a

- Regarding connectors, they are not stocked as they are not the initial order items.
The connectors are available after they are supplied from connector manufacturers upon the order is received.

○チップ抵抗部品コード/CHIP RESISTOR PART CODE

チップ抵抗部品コードの成り立ち

Chip Resistor Part Coding

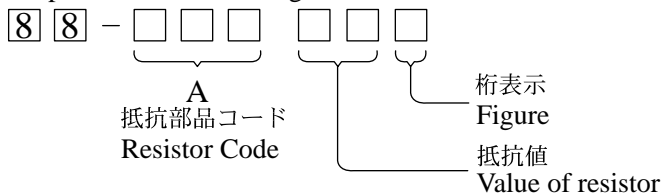

チップ抵抗
Chip resistor

容量 Wattage	種類 Type	許容誤差 Tolerance	記号 Symbol	寸法/Dimensions (mm)			抵抗コード : A Resistor Code : A	
				外形/Form	L	W		t
1/16W	1005	± 5%	CJ		1.0	0.5	0.35	104
1/16W	1608	± 5%	CJ		1.6	0.8	0.45	108
1/10W	2125	± 5%	CJ		2	1.25	0.45	118
1/8W	3216	± 5%	CJ		3.2	1.6	0.55	128

TRANSISTOR ILLUSTRATION -1/1

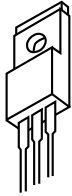

B C E

2SB1342
2SB1370E
2SD1933



E C B

2SA1980G
2SA1981Y
2SC3331(T/U)



E C B

2SC5343GL

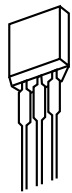

E C B

2SA1585SR

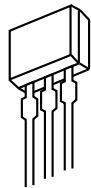

S D G

2SJ460
2SK2541

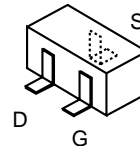

2SK360E

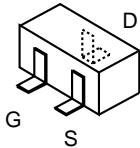

2SK2158

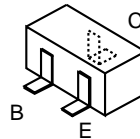

2SA1235F
2SC2620B
2SC3052F
2SC5345SF/S(O)

2SC5477
2SD1306E
SRA2202S
SRA2207S

MAIN C.B 1/2 (AMP SECTION)

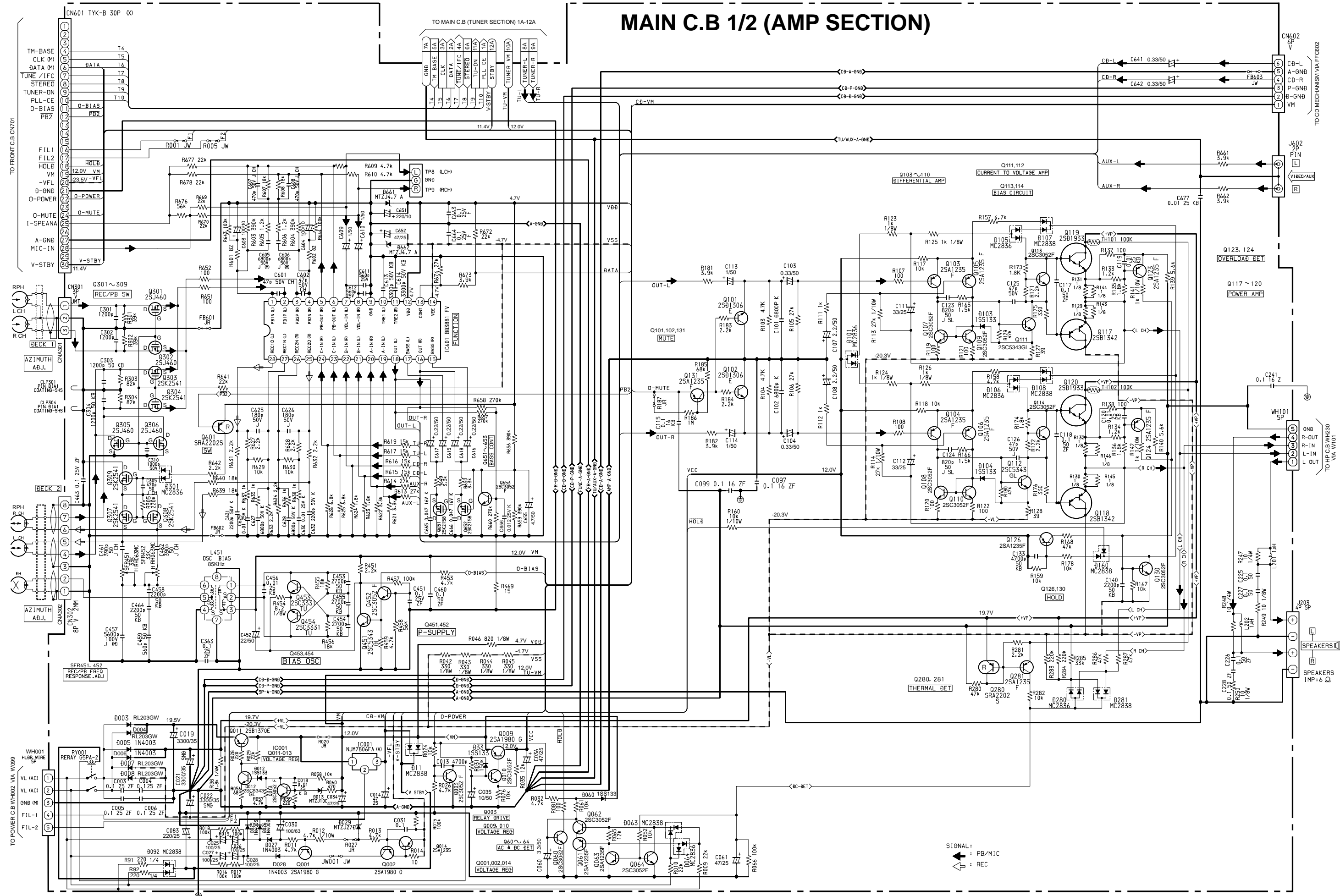

SIGNAL:
 ◀ : PB/MIC
 ▶ : REC

MAIN C.B 2/2 (TUNER SECTION)

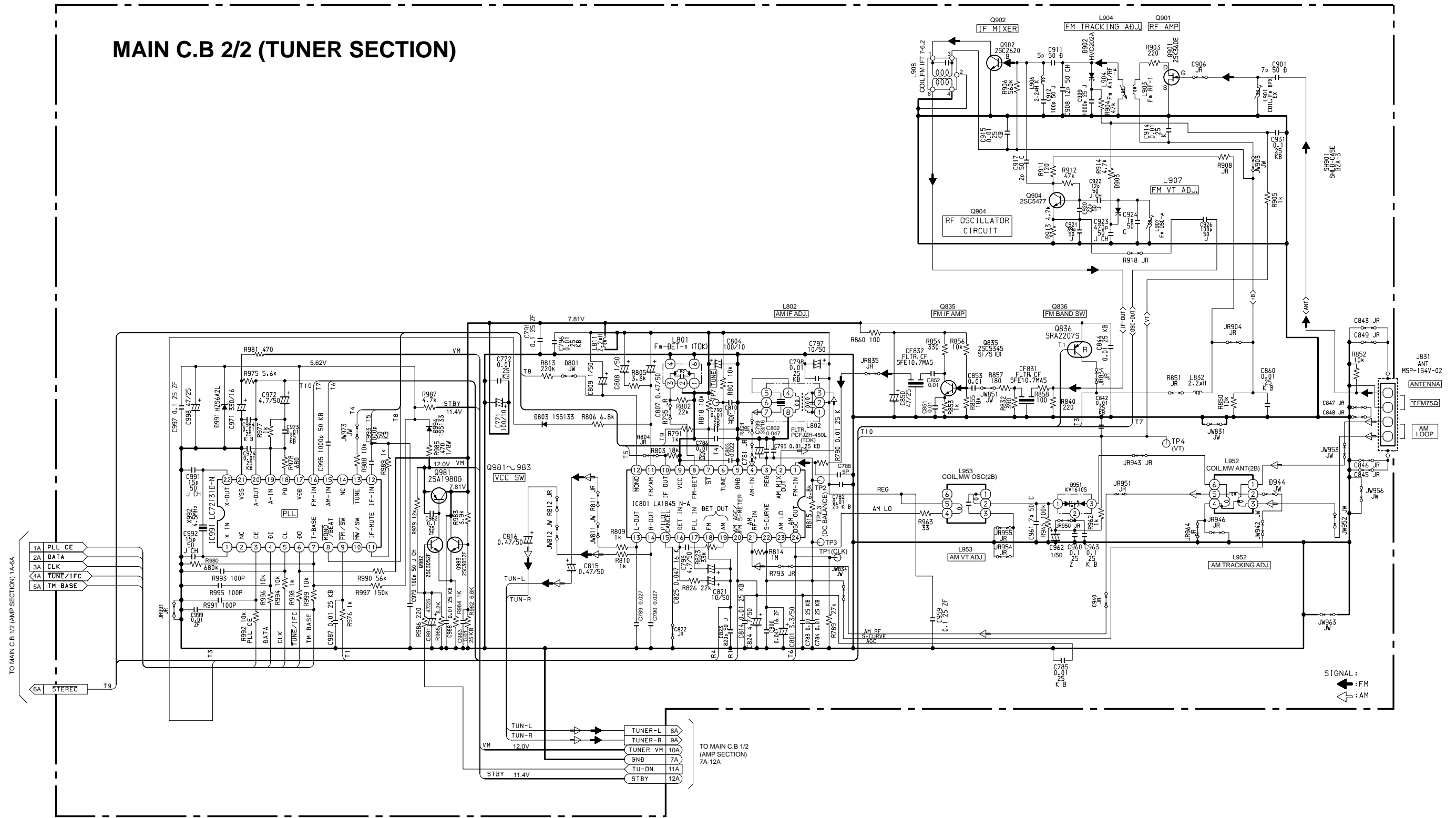

SCHEMATIC DIAGRAM -3/5 (HP SECTION)

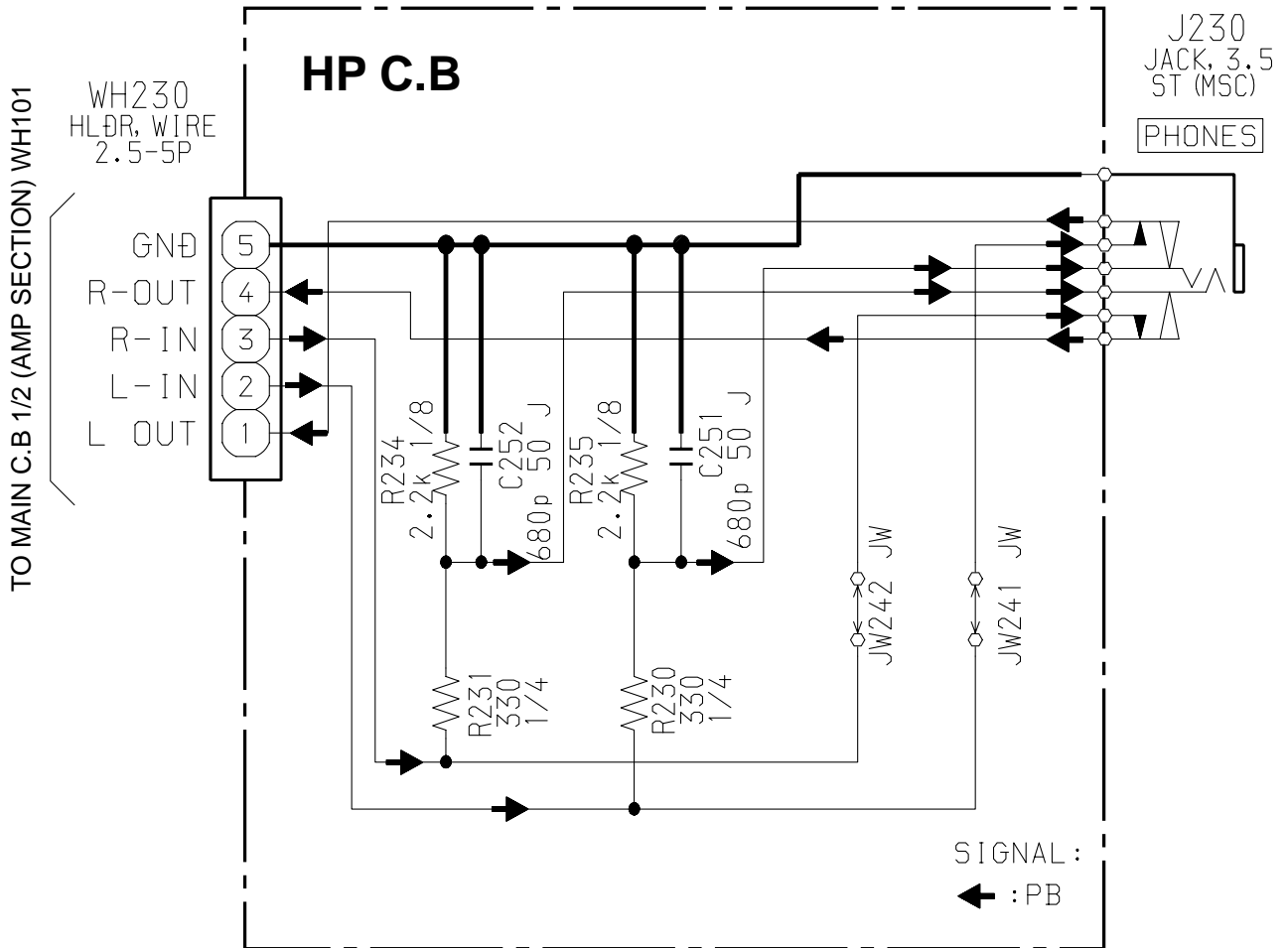

MAIN C.B

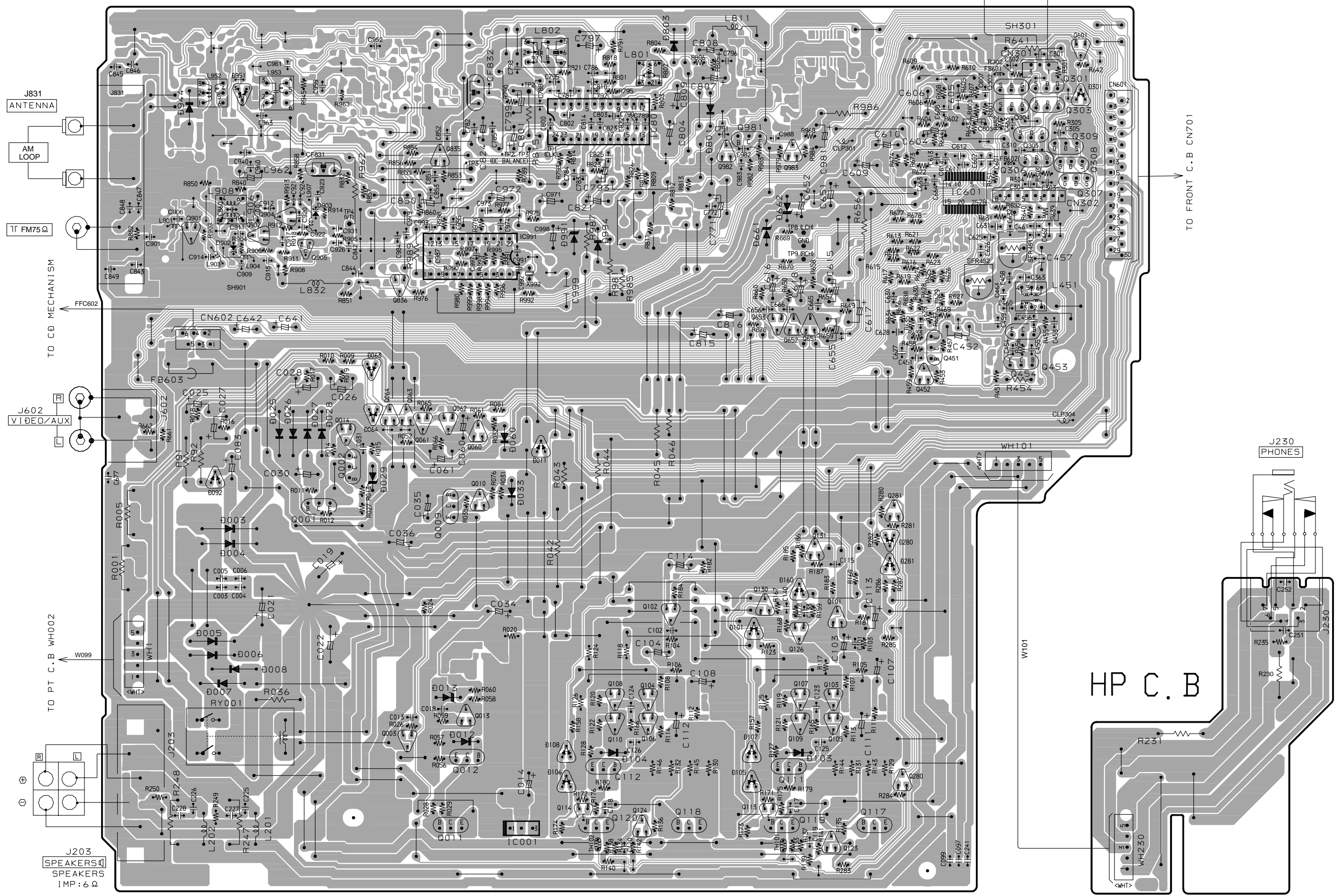

HP C.B

SCHEMATIC DIAGRAM - 4/5 (FRONT/MIC/DECK SECTION)

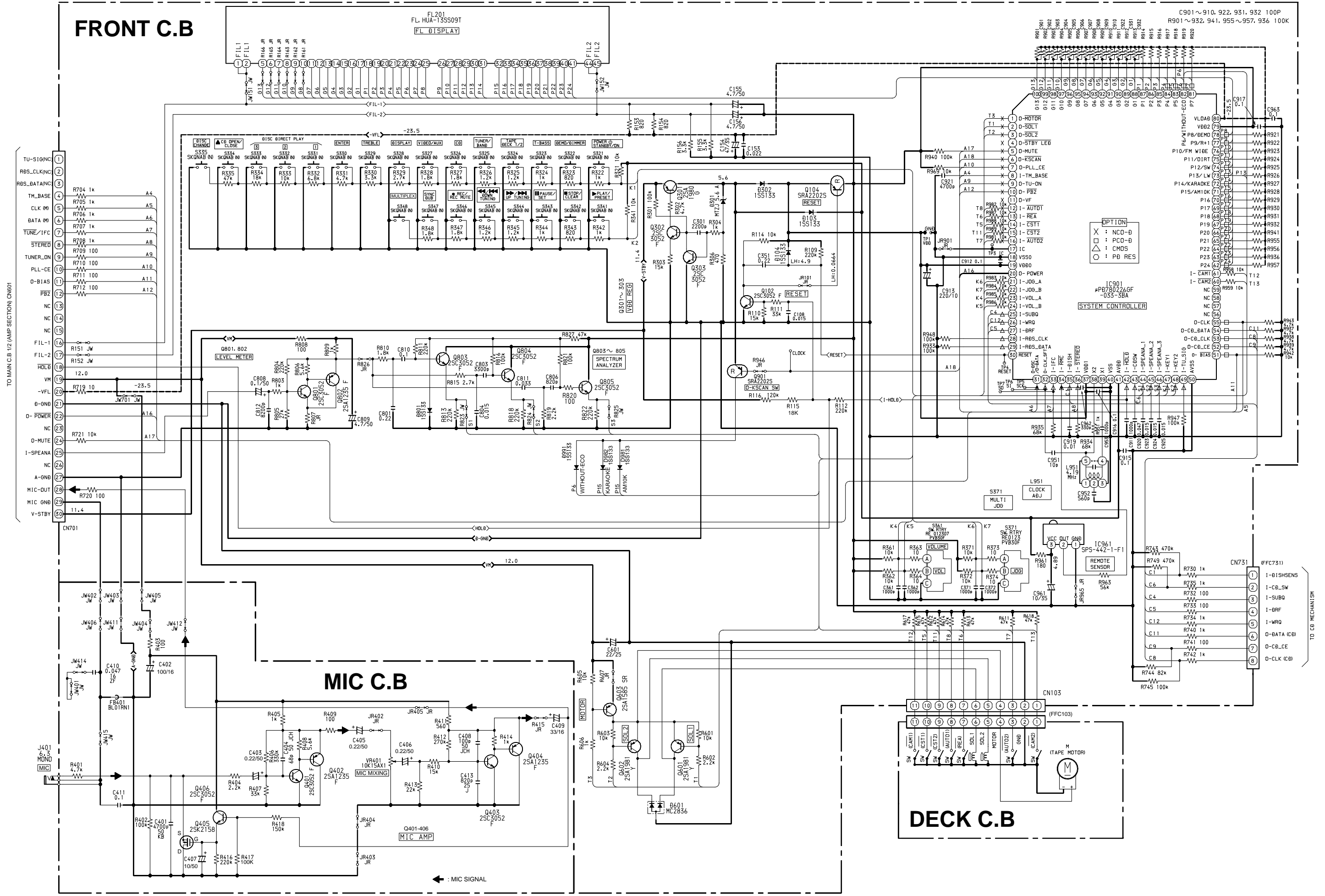

FRONT C.B

IC961
REMOTE SENSOR

FL201
FL DISPLAY

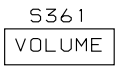
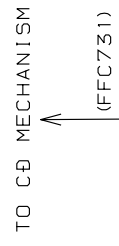
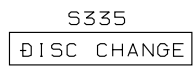
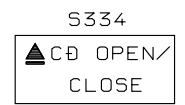
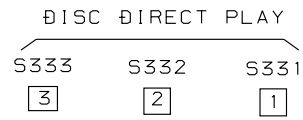

MIC C.B

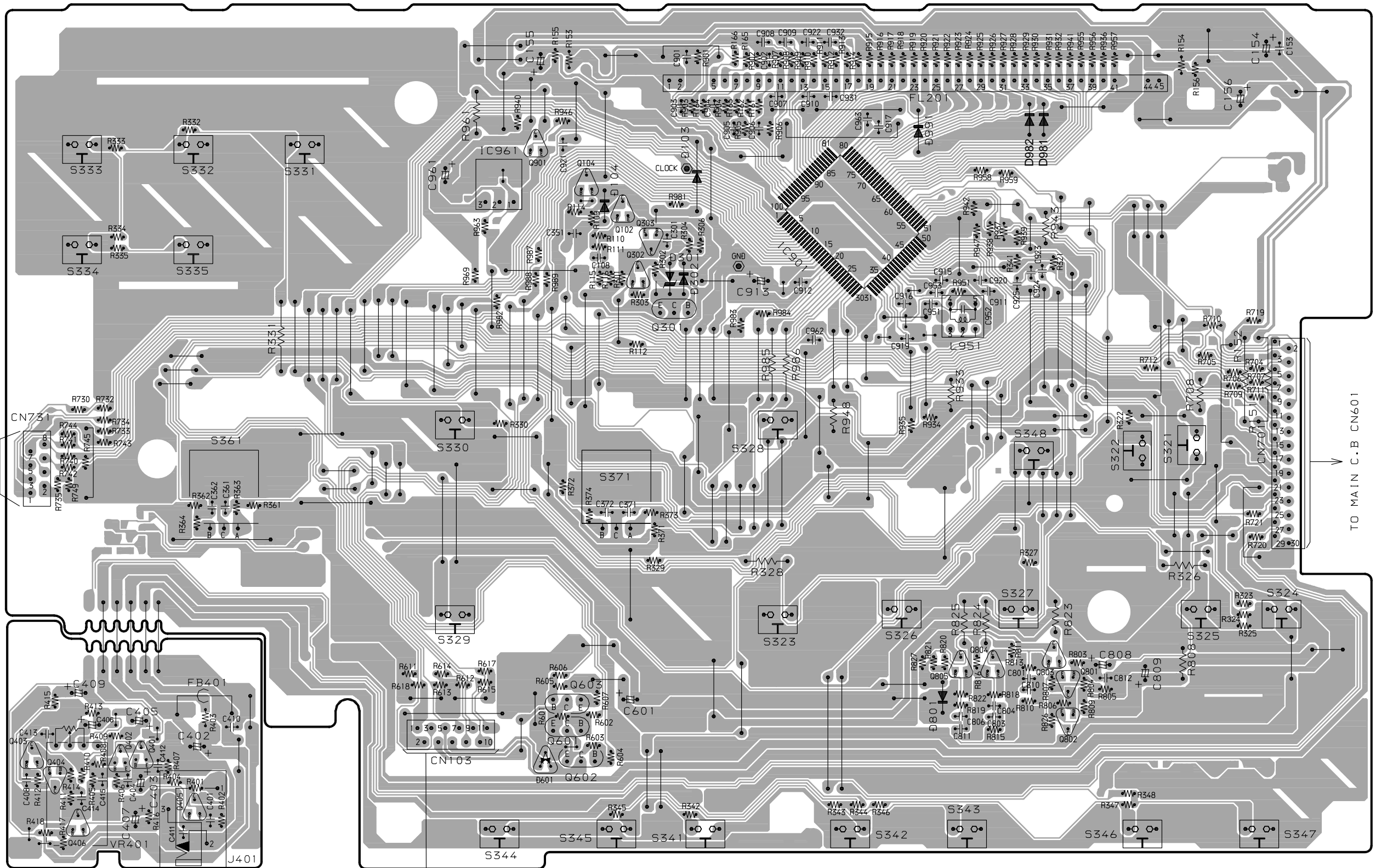

VR401
MIC MIXING

J401
MIC

TO DECK C.B
S329 TREBLE
S330 ENTER

(FFC101)
S371 MULTI JOG
S345 DOWN TUNING

S328 DISPLAY
S323 T-BASS

S348 MULTIPLEX
S326 CD

S322 DEMO/DIMMER
S325 TUNER/BAND

S321 POWER STANDBY/ON
S324 TAPE/DECK 1/2

S344 UP TUNING

S341 PLAY/PRESET

S342 STOP/CLEAR

S343 PAUSE/SET

S346 REC/REC MUTE

S347 SYNC DUB

TO MAIN C.B CN601

A
B
C
D
E
F
G
H
I
J
K
L
M
N
O
P
Q
R
S
T
U

32	31	30	29	28	27	26	25	24	23	22	21	20	19	18	17	16	15	14	13	12	11	10	9	8	7	6	5	4	3	2	1
----	----	----	----	----	----	----	----	----	----	----	----	----	----	----	----	----	----	----	----	----	----	----	---	---	---	---	---	---	---	---	---

DECK C.B

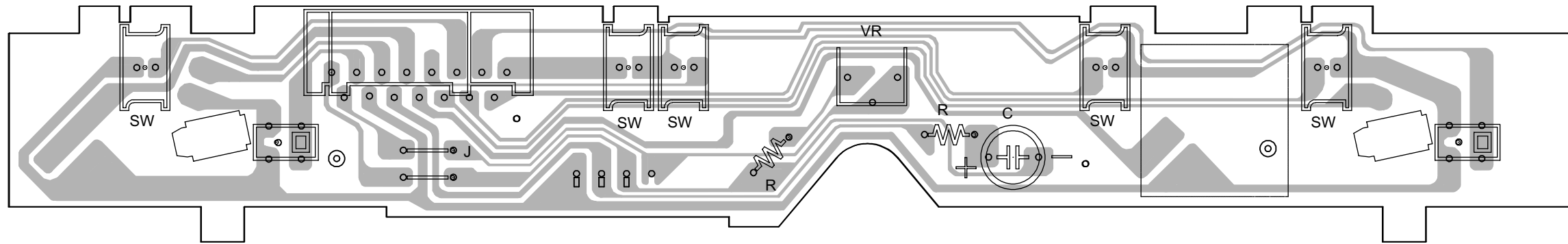

DECK 1
P HEAD

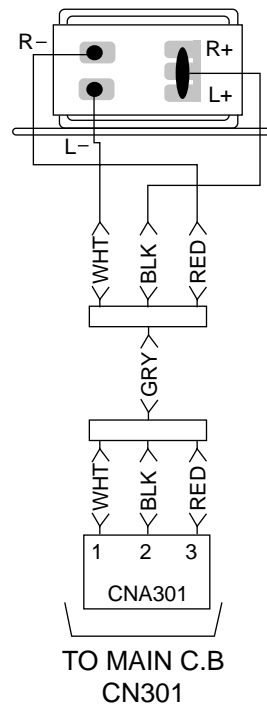

DECK 2
E / RP HEAD

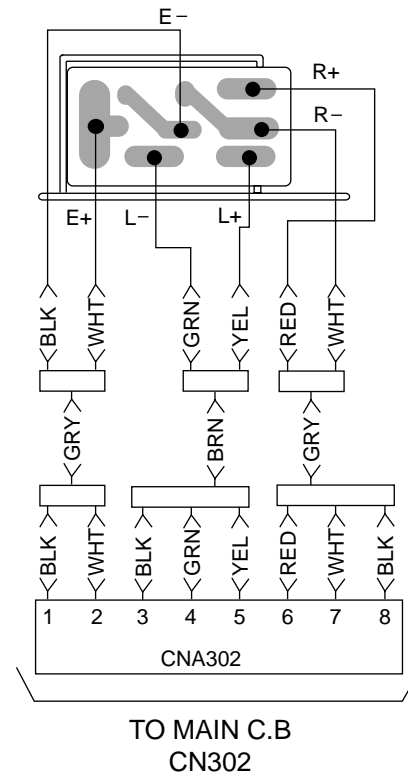

A
B
C
D
E
F
G
H
I
J
K
L
M
N
O
P
Q
R
S
T
U

SCHEMATIC DIAGRAM -5/5 (PT SECTION)

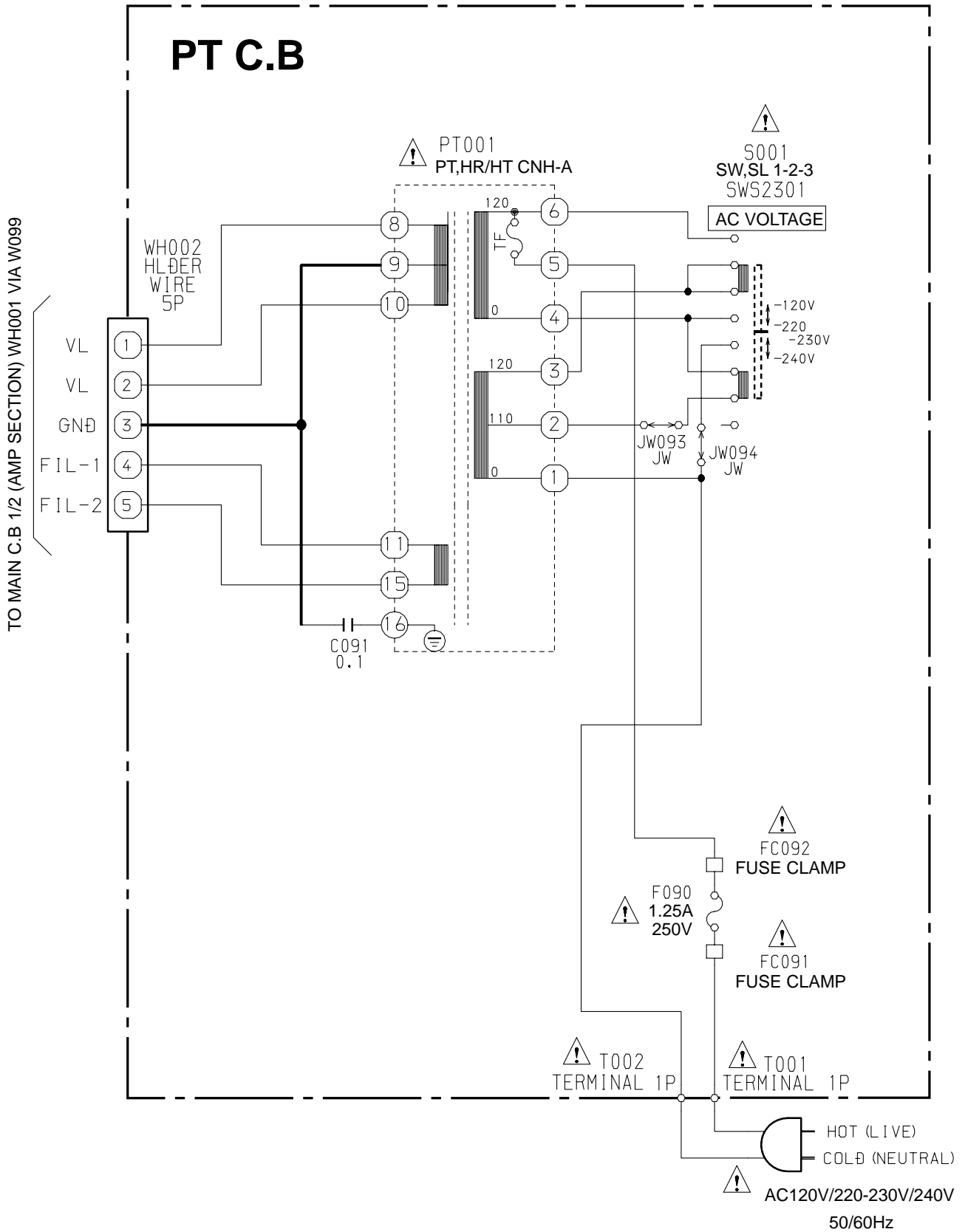

WIRING - 4/4 (PT C.B)

15	14	13	12	11	10	9	8	7	6	5	4	3	2	1
----	----	----	----	----	----	---	---	---	---	---	---	---	---	---

A
B
C
D
E
F
G
H
I
J
K
L
M
N
O
P
Q
R
S
T
U

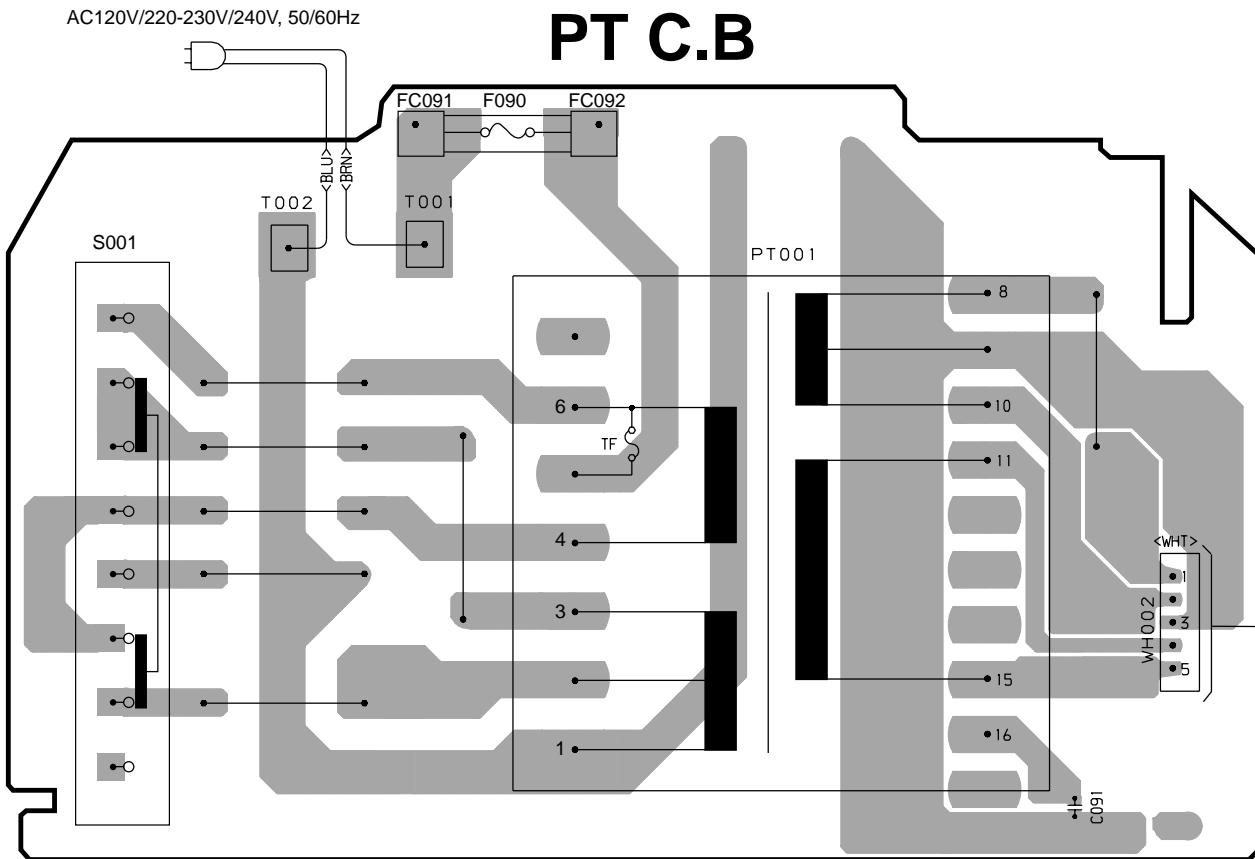

TO MAIN C.B WH001
(W099)

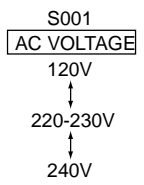

ELECTRICAL ADJUSTMENT -1/6

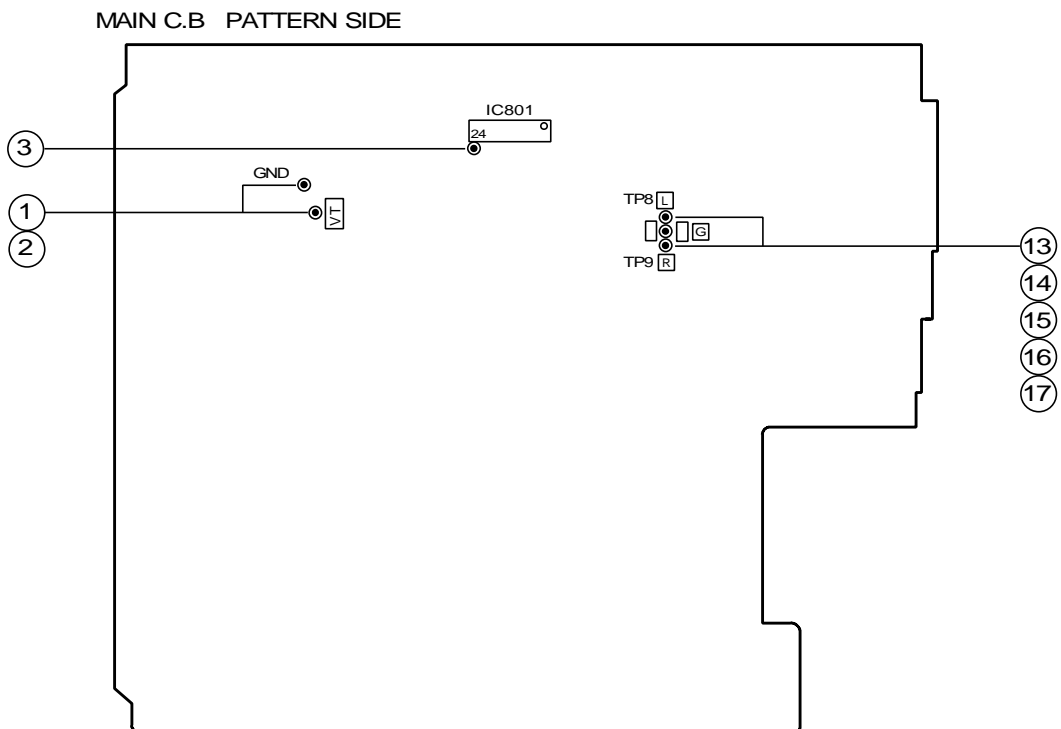
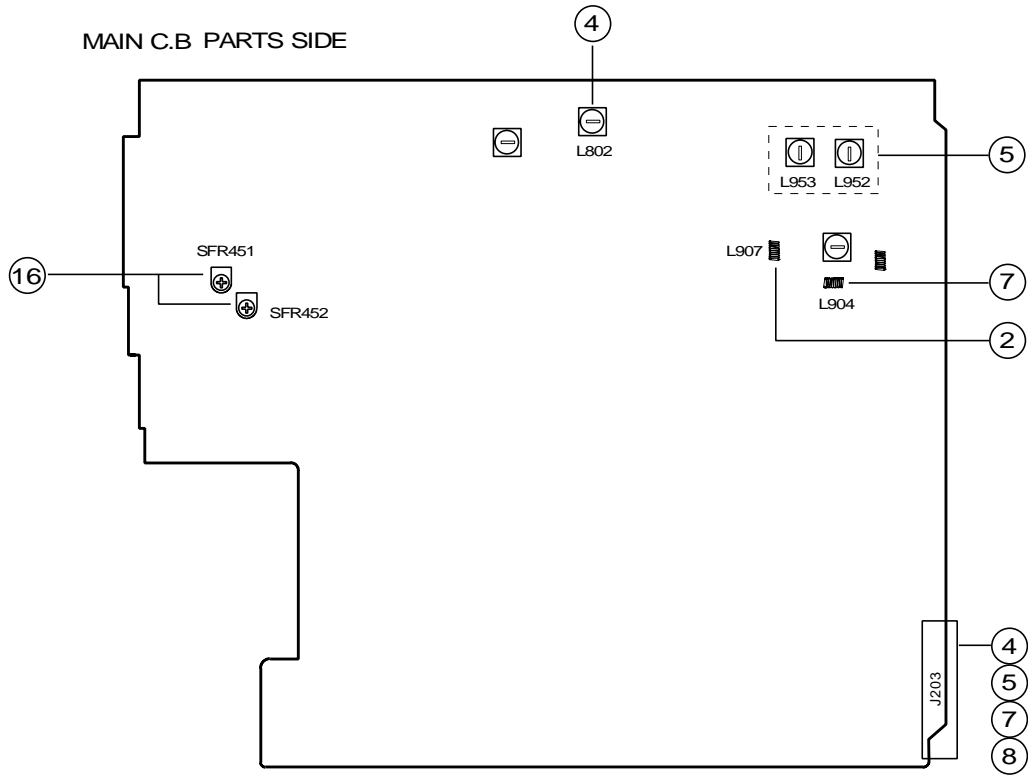

DECK C.B

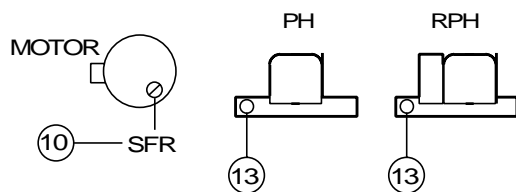

ELECTRICAL ADJUSTMENT -2/6

<TUNER Adjustment>

1. VT Check (AM)

Requirements

* Measuring instrument: Digital multimeter

Test point: VT, GND

- (1) Connect the digital multimeter to VT and GND.
- (2) Set the unit function to AM, and adjust the receiving frequency to 1,710 kHz.
- (3) Check that the digital multimeter indicates 9.0 V or below.
- (4) Adjust the receiving frequency of the unit to 530 kHz.
- (5) Check that the digital multimeter indicates 0.5 V or above.

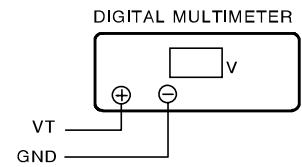

2. VT Adjustment and Check (FM)

Requirements: Same as Item 1.

Adjustment point: L907

- (1) Connect the digital multimeter to VT and GND.
- (2) Set the unit function to FM, and adjust the receiving frequency at 108.0 MHz.
- (3) Adjust L907 so that the digital multimeter indicates 7.0 ± 0.1 V.
- (4) Adjust the receiving frequency of the unit to 87.5 MHz.
- (5) Check that the digital multimeter indicates 1.5 V or above.

3. Clock Check (AM)

Requirements

* Measuring instrument: Frequency counter

Test point: CLOCK (IC801 24PIN), GND

- (1) Connect the frequency counter to CLOCK and GND.
- (2) Set the unit function to AM, and adjust the receiving frequency to 1,710 kHz.
- (3) Check that the frequency counter indicates $2,052 \text{ kHz} \pm 45 \text{ Hz}$.

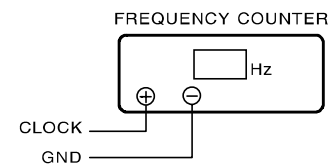

<AM Adjustment>

Make sure that the following settings are done before adjustment.

Preparation

* Measuring instruments:

Standard Signal Generator (S.S.G.) / Loop antenna / Oscilloscope / Millivoltmeter / Dummy resistor (6Ω)

- (1) Connect the measuring instruments as shown in the diagram below.
- (2) Keep a distance of 60cm between the loop antenna of signal generator and the one connected to the unit.

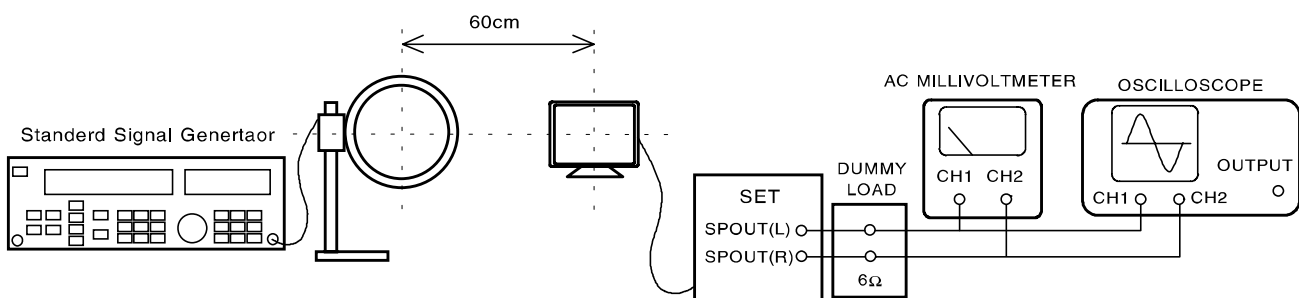

4. IF Adjustment

Requirements

* Test point: SP OUT (Lch, Rch)

Adjustment point: L802

- (1) Adjust the S.S.G. setting to AM; carrier at 1000 kHz with 30% modulation, and source at 1 kHz, position output at maximum.
- (2) Adjust the unit to AM 1000 kHz.
- (3) While monitoring the 1 kHz waveform through oscilloscope, decrease the S.S.G. output level (till slight noises appear in the waveform).
- (4) Adjust L802 so that the millivoltmeter indicates maximum.

ELECTRICAL ADJUSTMENT -3/6

5. Tracking Adjustment

Requirements: Same as Item 4.

* Adjustment point: L952 / L953

- (1) Adjust the S.S.G. setting to AM; carrier at 1000 kHz with 30% modulation, and source at 1 kHz, position output at maximum.
- (2) Adjust the unit to AM 1000 kHz.
- (3) While monitoring the 1 kHz waveform through oscilloscope, decrease the S.S.G. output level (till slight noises appear in the waveform.)
- (4) Adjust L952 so that the millivoltmeter indicates maximum.
- (5) Adjust the S.S.G setting to AM; carrier at 600 kHz; distortion rate at 30 %, and source at 1 kHz.
- (6) Adjust the unit to AM 600 kHz.
- (7) Adjust L953 so that the millivoltmeter indicates maximum.
- (8) Repeat above steps (1) to (7) two or three times.

6. Auto-Stop Function Check

Requirements: Same as Item 4.

- (1) Adjust the S.S.G setting to AM; carrier at 1000 kHz; distortion rate at 30 %; source at 1 kHz, and output at 40 ~ 65 dBuV.
- (2) Start the tuning search mode, and check that the auto-stop function is applied at AM 1000 kHz.

<FM Adjustment>

Make sure that the following settings are done before adjustment.

Preparation

* Measuring instruments: Standard Signal Generator (S.S.G.) / Oscilloscope / Millivoltmeter / Dummy resistor (6Ω)

- (1) Connect the measuring instruments as shown in the diagram below.
- (2) Connect the output terminal of signal generator to the antenna input terminal of the unit.

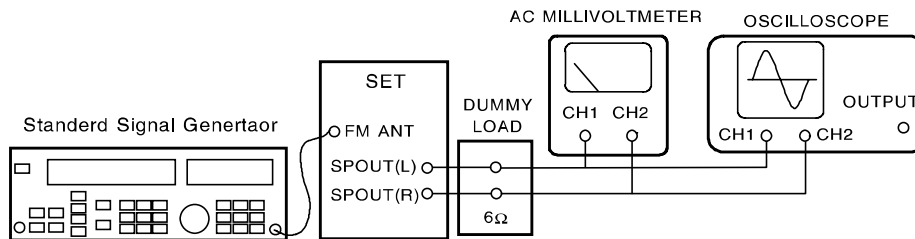

7. Tracking Adjustment

Requirements

* Test Point: SPOUT (Lch, Rch)

Adjustment point: L904

- (1) Adjust the S.S.G. setting to FM; carrier at 87.5 MHz, distortion at 75 kHz, and source 1 kHz, position output at maximum.
- (2) Adjust the unit to FM 87.5 MHz.
- (3) While monitoring the waveform at 1kHz through the oscilloscope, lower the output level of S.S.G. maximum (till a certain degree of noise is monitored).
- (4) Adjust L904 so that the millivoltmeter points maximum.

8. Separation Check

Requirements: Same as Item 7.

- (1) Adjust the S.S.G. setting to FM; carrier at 98 MHz; distortion at 67.5 kHz; source at 1 kHz, and output at 74 dBuV.
- (2) Switch the S.S.G. to PILOT ON, and set to PILOT 7.5 kHz.
- (3) Adjust the unit to FM 98 MHz.
- (4) Check that S.S.G outputs only from Lch and that the difference between Lch and Rch at that time is 22 dB or above.
- (5) Check for Rch in the same manner.

9. Auto-Stop Function Check

Requirements: Same as Item 4.

- (1) Adjust the S.S.G. setting to FM; carrier at 98 MHz; distortion at 75 kHz; source at 1 kHz and output at 10 ~ 35 dBuV.
- (2) Start the tuning search mode, and check that the auto-stop function is applied at FM 98 MHz.

ELECTRICAL ADJUSTMENT -4/6

<Deck Section>

10. Tape Speed Adjustment (DECK 2)

Requirements

* Measuring instruments: Wow-flutter meter (frequency counter)

Test tape: TTA-100 (3 kHz)

Test point: HP OUT

Adjustment point: DECK MOTOR SFR

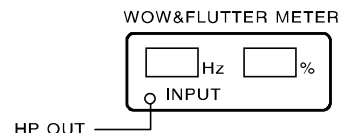

- (1) Connect the HP OUT terminal of the unit to the wow-flutter meter.
- (2) Insert the test tape (TTA-100) to DECK 2. Playback the middle part of the tape in the FWD direction, and adjust DECK MOTOR SFR so that the level, 3,000 Hz \pm 45 Hz can be obtained.

11. Tape Speed Check (DECK 1)

Requirements: Same as Item 10.

- (1) Insert the test tape (TTA-100) to DECK 1. Playback the middle part of the tape, and check that the range within \pm 45 Hz is obtained against the speed of DECK 2.

12. Wow-Flutter Check (DECK 1, DECK 2)

Requirements: Same as Item 10.

- (1) Connect the HP OUT terminal of the unit to the wow-flutter meter.
- (2) Switch the wow-flutter setting from INDICATOR to JIS, and from a mode to W RMS (WTD).
- (3) Playback the middle part of the test tape (TTA-100), and check that the level is 0.25 % or below.

13. Head Azimuth Adjustment (DECK 1, DECK 2)

Requirements

* Measuring instrument: Oscilloscope

Test tape: TTA-300 (10 kHz)

Test point: TP8 (Lch), TP9 (Rch)

Adjustment point: Head azimuth adjustment screw

- (1) Connect the CH1 of the oscilloscope probe to TP8 (Lch) and the CH2 to TP9 (Rch).
- (2) Set the V mode of the oscilloscope to ADD.
- (3) Insert the test tape (TTA-300) to DECK 1. Playback the middle part of the tape in the FWD direction, and adjust the head azimuth adjustment screw so that the waveform reaches maximum when 10 kHz is played.
- (4) After adjustment, lock the screw by bonding (1600B).
- (5) Apply the above steps (3) to (4) to DECK 2.

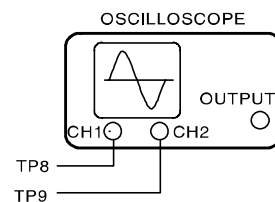

14. Playback Frequency Check (DECK 1, DECK 2)

Requirements

* Measuring instrument: Millivoltmeter

Test tape: TTA-300 (315 Hz / 10 kHz)

Test point: TP8 (Lch), TP9 (Rch)

- (1) Connect the CH1 of millivoltmeter to TP8 (Lch) and the CH2 to TP9 (Rch).
- (2) Insert the test tape (TTA-300) to DECK 1, and playback 315 Hz and 10 kHz.
- (3) Check that the 10 kHz level is ranged within 0 ± 3 dB compared to the output reference level of 315 Hz.
- (4) Apply the above steps (2) and (3) to DECK 2.

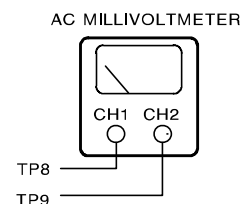

ELECTRICAL ADJUSTMENT -5/6

15. Playback Sensitivity Check (DECK 1, DECK 2)

Requirements

* Measuring instrument: Millivoltmeter

Test tape: TTA-200 (400 Hz)

Test point: TP8 (Lch), TP9 (Rch)

- (1) Connect the CH1 of millivoltmeter to TP8 (Lch) and the CH2 to TP9 (Rch).
- (2) Insert the test tape (TTA-200) to DECK 1 to playback.
- (3) Check that the output level is ranged within $110 \text{ mV} \pm 3 \text{ dB}$.
- (4) Apply the above steps (2) and (3) to DECK 2.

16. Playback/Record Frequency Response Adjustment (DECK 2)

Requirements

* Measuring instruments: Millivoltmeter

Audio signal oscillator (low-frequency oscillator)

Attenuator

Test tape: TTA-602 (NORMAL)

Test point: TP8 (Lch), TP9 (Rch)

Input point: AUX (1 kHz / 8 kHz)

Adjustment point: SFR451 (Lch), SFR452 (Rch)

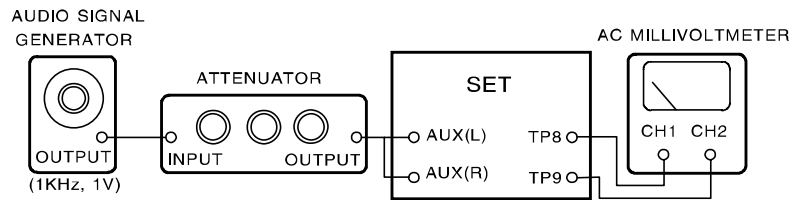

- (1) Connect the CH1 of millivoltmeter to TP8 (Lch) and the CH2 to TP9 (Rch).
- (2) Connect the output terminal of oscillator to attenuator, and then attenuator to AUX of the unit.
- (3) Insert the test tape (TTA-602) to DECK 2, and record the 1 kHz signal from AUX.
- (4) Adjust the attenuator so that the output levels of TP8 and TP9 become 10 mV.
- (5) Record 1 kHz and 8 kHz alternately.
- (6) Adjust SFR451 (Lch) and SFR452 (Rch) so that the playback output level of 8 kHz is ranged within $0 \pm 1 \text{ dB}$ compared to the playback output reference level of 1 kHz.

17. Playback/Record Sensitivity Check (DECK 2)

Requirements

* Measuring instrument: Same as Item 16.

Test tape: TTA-602 (NORMAL)

Test point: TP8 (Lch), TP9 (Rch)

Input point: AUX (10 kHz)

- (1) Insert the test tape (TTA-602) to DECK 2, and record the 10 kHz signal from AUX.
- (2) Adjust the attenuator so that the output levels of TP8 and TP9 become 100 mV.
- (3) Playback 10 kHz, and check that the output level is ranged within $0 \text{ dB} \pm 2.5 \text{ dB}$ compared to the output level during recording.

ELECTRICAL ADJUSTMENT -6/6

<Front Section>

FRONT C.B. PATTERN SIDE

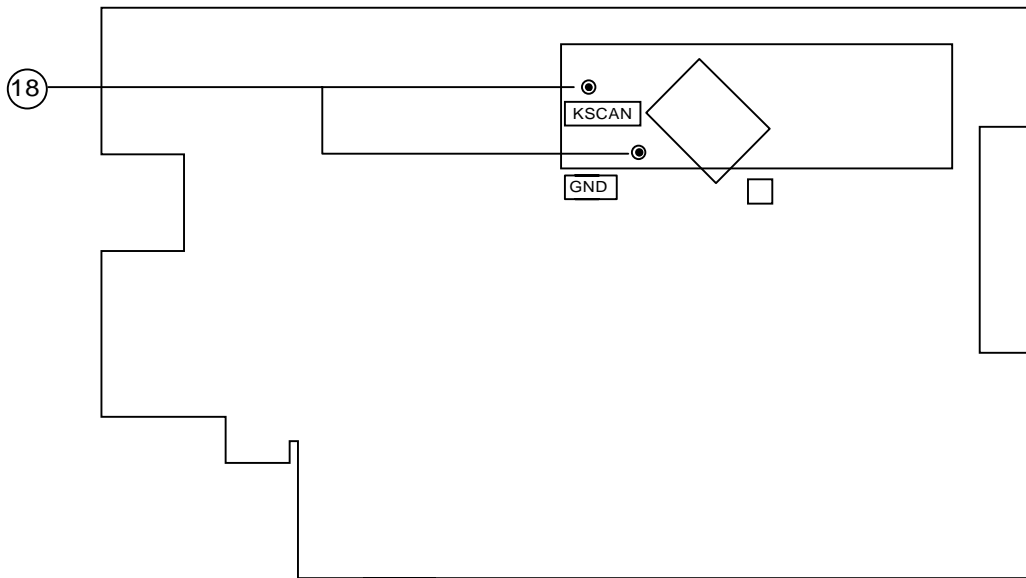

FRONT C.B. PARTS SIDE

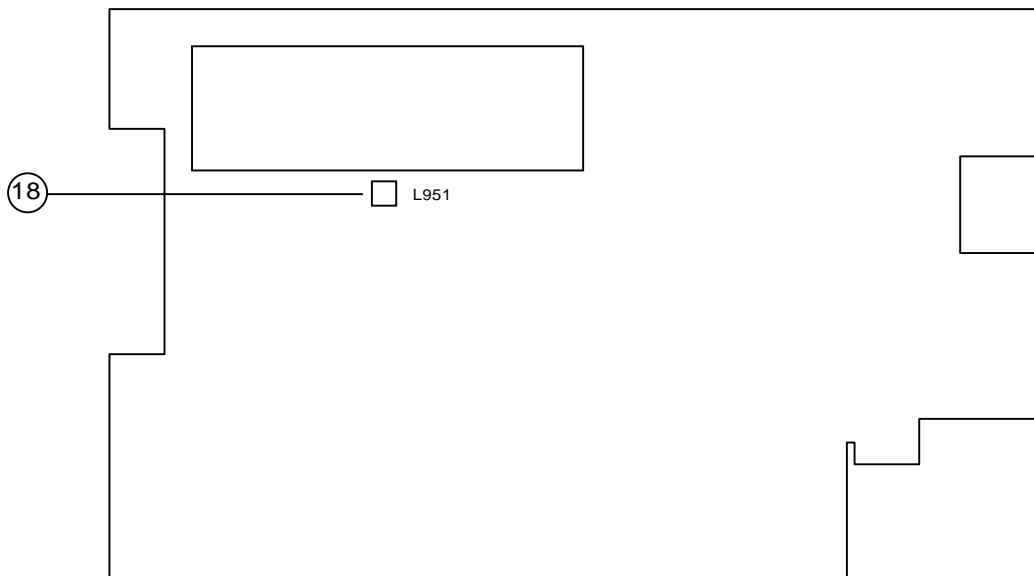

18. Clock Adjustment

Requirement

* Measuring instrument: Frequency counter

Test point: CLOCK, GND

Adjustment point: L951

- (1) While pressing and holding down the POWER button and the UP button, insert the AC plug.
- (2) Adjust L951 so that the frequency counter indicates 72.743 ± 0.073 Hz.

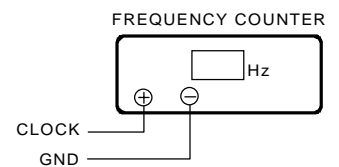

CD TEST MODE -1/1

1. Starting CD Test Mode

While pressing and holding down the CD OPEN/CLOSE button, insert the AC plug to outlet.
When test mode starts, the message, TEST appears on the display.

2. Exiting CD Test Mode

Press the other function button, POWER button or remove the AC plug from outlet.

3. Function of CD Test Mode

No	Mode	Function Key	Display	Movement	Check
1	Start Mode		All lit.	FL all lit.	<ul style="list-style-type: none"> • FL check • Microcomputer check
2	Search Mode	STOP button	READING	<ul style="list-style-type: none"> • LD constantly lit. • Focus search continuous movement *1, 2 • Spindle motor continuous kick 	<ul style="list-style-type: none"> • APC circuit check • Laser current electricity measurement • Focus search waveform check • Focus error waveform check (DRF is ignored during search mode.)
3	Play Mode	PLAY button	Normal	<ul style="list-style-type: none"> • Normal playback • If TOC READ is unavailable, focus search is continued. 	<ul style="list-style-type: none"> • Each servo circuit check • DRF check • RF frequency check (approx. 1.7Vp-p)
4	Traverse Mode	PAUSE button	Normal	<ul style="list-style-type: none"> • Tracking servo OFF/ON OFF and ON is repeated by every press of the PAUSE button. 	<ul style="list-style-type: none"> • Tracking balance check
5	Sled mode	FF button	TEST	<ul style="list-style-type: none"> • PU moves to the innermost position. *3 At the same time, lens is kicked toward inner position. 	<ul style="list-style-type: none"> • Sled circuit check • Tracking circuit check • Mechanism movement check • PU check
		RWD button	TEST	<ul style="list-style-type: none"> • PU moves to the outermost position. *3 At the same time, lens is kicked toward outer position. 	
6	Spindle mode	● REC/ REC MUTE button	All lit.	<ul style="list-style-type: none"> • When the button is pressed at the first time, spindle motor rotates forward (at rough speed). At the second press, rotation is reversed. At the third press, rotation stops. 	<ul style="list-style-type: none"> • Spindle circuit check • Spindle motor check

* 1 When Focus Search operates continuously more than 10 minutes, the protection circuit is activated due to heat generation of the driver IC. In this case, turn off the power, wait for approximately 10 minutes so that heat is released, and then restart.

* 2 When Focus Search fails three times, the gain is switched for CD-RW at the fourth time.

* 3 Be careful not to damage the gear because the sled motor rotates while the FF or RWD button is being pressed even if the pickup is located in the innermost track or the outermost track.

GRID ASSIGNMENT

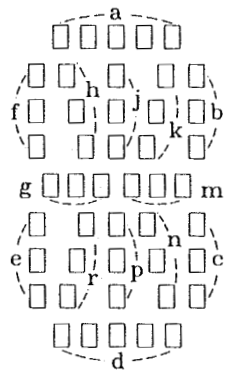
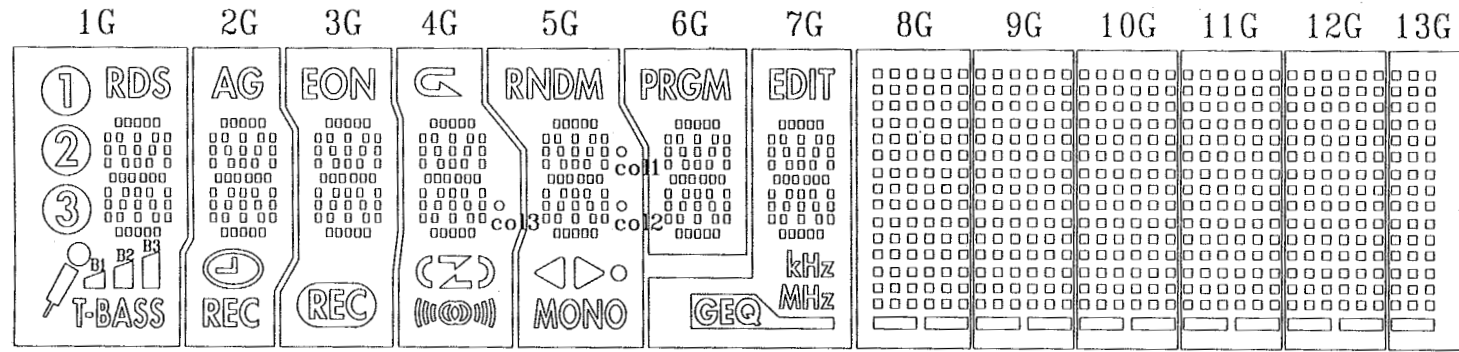

(1G - 7G)

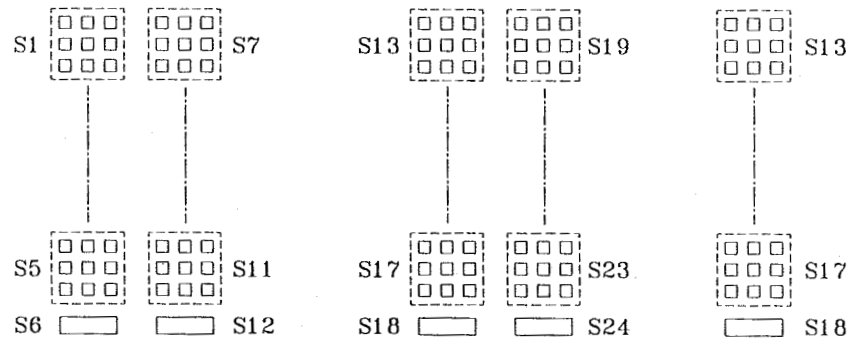

(8G,10G,12G)

(9G,11G)

(13G)

ANODE CONNECTION

	1G	2G	3G	4G	5G	6G	7G	8G	9G	10G	11G	12G	13G
P1	RDS	AG	EON	⏪	RNDM	PRGM	EDIT	S1	—	S1	—	S1	—
P2	a	a	a	a	a	a	a	S7	—	S7	—	S7	—
P3	h	h	h	h	h	h	h	—	S13	—	S13	—	S13
P4	j	j	j	j	j	j	j	—	S19	—	S19	—	—
P5	k	k	k	k	k	k	k	S2	—	S2	—	S2	—
P6	b	b	b	b	b	b	b	S8	—	S8	—	S8	—
P7	f	f	f	f	f	f	f	—	S14	—	S14	—	S14
P8	m	m	m	m	m	m	m	—	S20	—	S20	—	—
P9	g	g	g	g	g	g	g	S3	—	S3	—	S3	—
P10	c	c	c	c	c	c	c	S9	—	S9	—	S9	—
P11	e	e	e	e	e	e	e	—	S15	—	S15	—	S15
P12	r	r	r	r	r	r	r	—	S21	—	S21	—	—
P13	p	p	p	p	p	p	p	S4	—	S4	—	S4	—
P14	n	n	n	n	n	n	n	S10	—	S10	—	S10	—
P15	d	d	d	d	d	d	d	—	S16	—	S16	—	S16
P16	①	⏪	REC	col3	col1	—	kHz	—	S22	—	S22	—	—
P17	②	REC	—	⏪	col2	—	MHz	S5	—	S5	—	S5	—
P18	③	—	—	⏪	o	—	GEQ	S11	—	S11	—	S11	—
P19	—	—	—	—	—	—	—	—	S17	—	S17	—	S17
P20	T-BASS	—	—	⏪	—	—	—	—	S23	—	S23	—	—
P21	B1	—	—	—	—	MONO	—	—	S6	—	S6	—	S6
P22	B2	—	—	—	—	—	—	—	S12	—	S12	—	S12
P23	B3	—	—	—	—	—	—	—	S18	—	S18	—	S18
P24	—	—	—	—	—	—	—	—	S24	—	S24	—	—

PIN CONNECTION

PIN NO.	45	44	43	42	41	40	39	38	37	36	35	34	33	32	31	30	29	28	27	26	25	24	23	22	21	20	19	18	17	16	15	14	13	12	11
CONNECTION	F2	F2	NP	NP	P24	P23	P22	P21	P20	P19	P18	P17	P16	P15	P14	P13	P12	P11	P10	P9	P8	P7	P6	P5	P4	P3	P2	P1	1G	2G	3G	4G	5G	6G	7G

Notes

- 1) F1,F2 : Filament pin
- 2) nG : Grid pin
- 3) Pn : Anode pin
- 4) NP : No pin

10	9	8	7	6	5	4	3	2	1
8G	9G	10G	11G	12G	13G	NP	NP	F1	F1

IC BLOCK DIAGRAM -1/2

IC, LC72131D-N

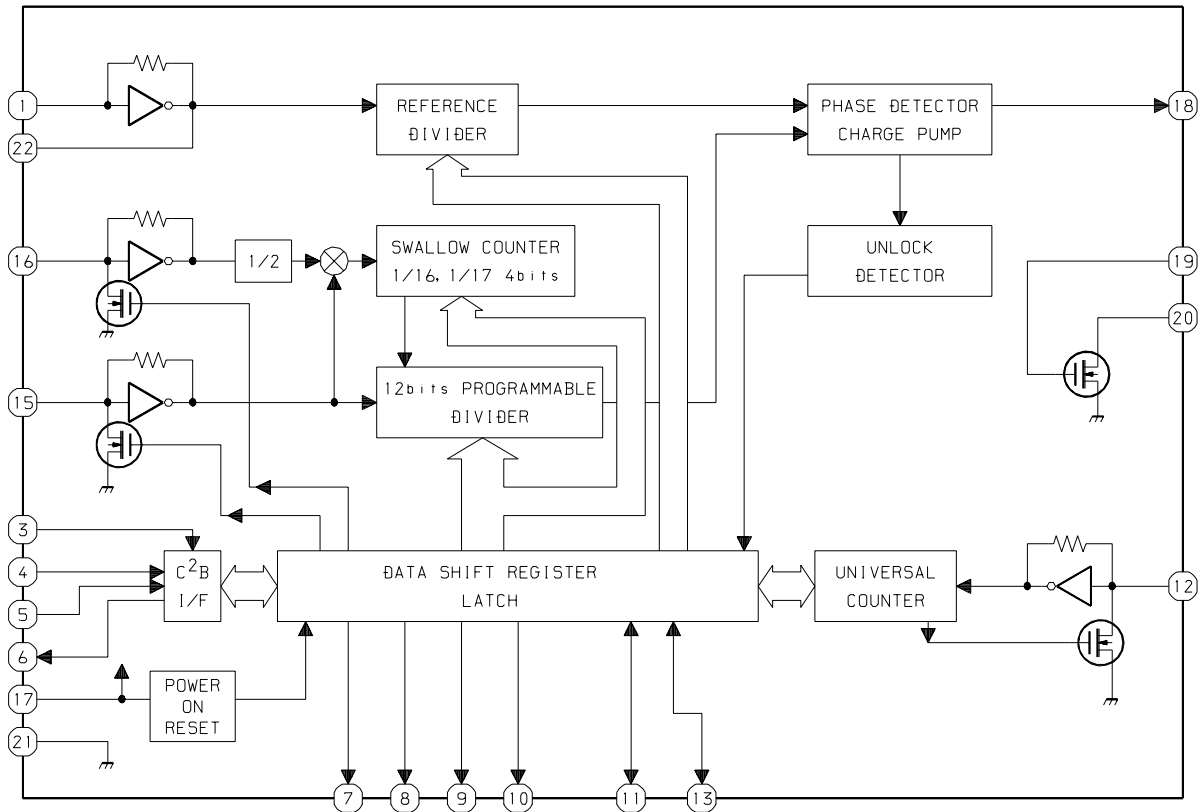

IC, BD3881FV

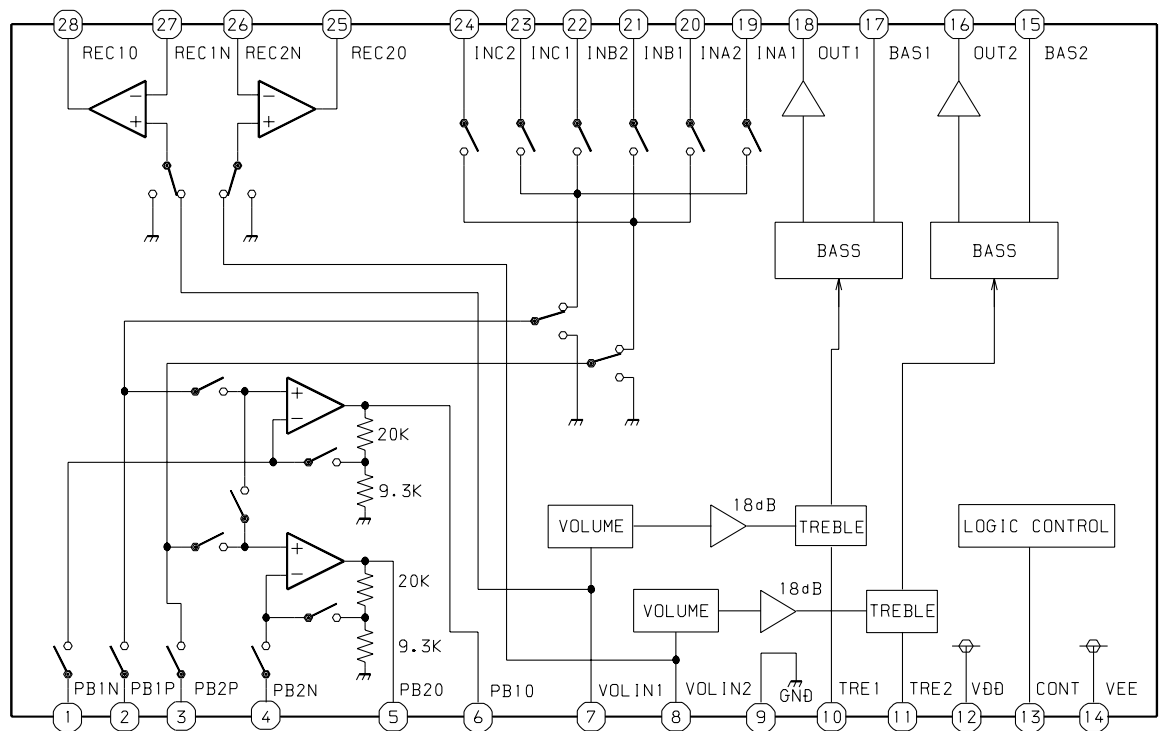

IC BLOCK DIAGRAM -2/2

IC, LA1845N-A

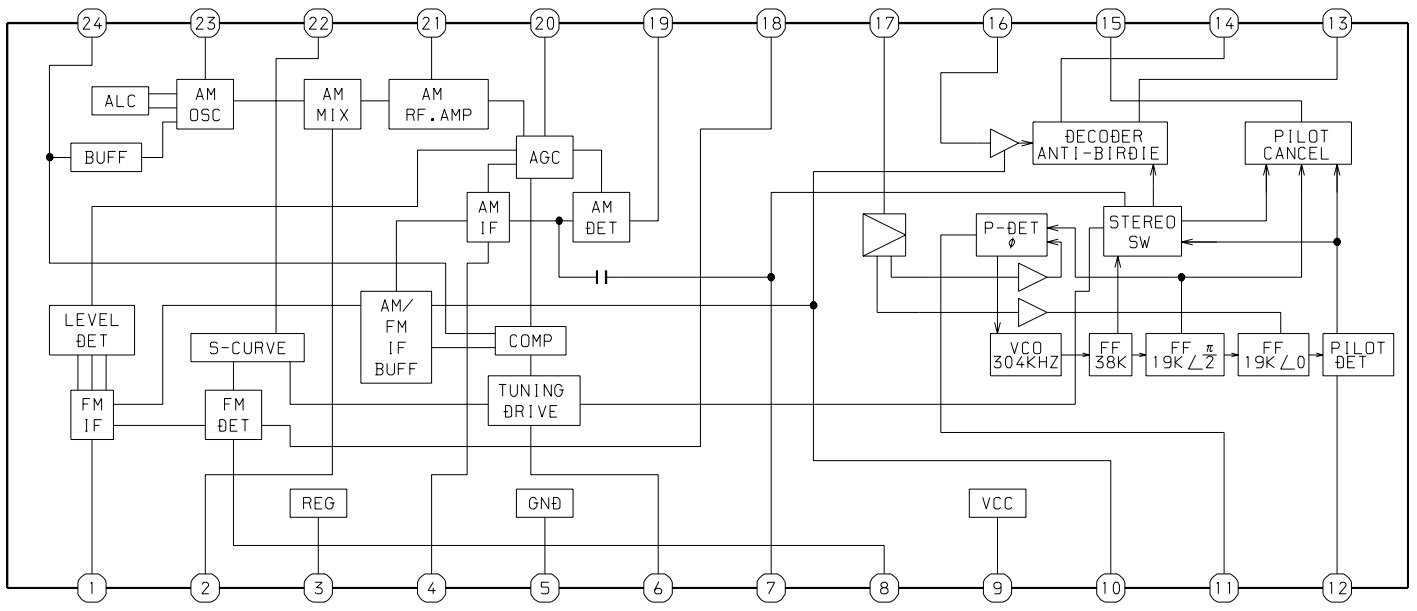

IC DESCRIPTION -1/1 (μ PD780226GF-033-3BA) -1/2

Pin No.	PinName	I/O	Description
1	O-MOTOR	O	DECK motor output.
2	O-SOL1	O	DECK1 solenoid output.
3	O-SOL2	O	DECK2 solenoid output.
4	O-STBY_LED	O	Standby LED output. (Not used)
5	O-MUTE	O	System mute ON/OFF output.
6	O-KSCAN	O	Key scan timing output.
7	O-PLL_CE	O	PLL chip enable output for LC72131D-N.
8	I-TM_BASE	I	Time-base signal input.
9	O-TU-ON	O	Tuner ON/OFF output.
10	O-PB2	O	DECK2 play back ON/OFF output.
11	O-VF	-	Not used.
12	I-AUTO1	I	DECK1 detecting reel rotation switch input.
13	I-REA	I	DECK2 prevention for mistaken recording switch input.
14	I-CST1	I	DECK1 cassette detect switch input.
15	I-CST2	I	DECK2 cassette detect switch input.
16	I-AUTO2	I	DECK2 detecting reel rotation switch input.
17	IC	-	GND.
18	VSS0	-	GND.
19	VDD0	-	Power supply input.
20	O-POWER	O	System power supply ON/OFF output.
21	I-JOG_A	I	JOG rotary encoder signal input (A/D).
22	I-JOG_B	I	JOG rotary encoder signal input (A/D).
23	I-VOL_A	I	VOL rotary encoder signal input (A/D).
24	I-VOL_B	I	VOL rotary encoder signal input (A/D).
25	I-SUBQ	I	CD SUBQ serial input.
26	I-WRQ	I	CD IC control input.
27	I-DRF	I	CD IC control input.
28	I-RDS_CLK	I	Tuner RDS clock output for BU1920FS.
29	I-RDS_DATA	I	Tuner RDS data output for BU1920FS.
30	RESET	I	Reset input.
31	O-DSC/O-DATA	O	Serial data latch output for BD3881FV / PLL data output for LC72131D-N.
32	O-CLK_SFT	O	MICON clock shift output.
33	I-IFC	I	Tune IF count serial data input.
34	I-RMC	I	System remote control signal input.
35	I-DISH	I	CD turntable photo sensor signal input.
36	I-STEREO	I	Tuner stereo detected input.
37	VDD1	-	Power supply input.
38	X2	-	4.19MHz oscillator circuit.
39	X1	-	4.19MHz oscillator circuit.
40	VSS	-	GND.
41	AVDD	-	GND.
42	I-HOLD	I	Power failure detected input "L" to stop clock and hold memory.
43	I-CDSW	I	CD mechanical switch A/D converter input.

IC DESCRIPTION -1/1 (μPD780226GF-033-3BA) -2/2

Pin No.	PinName	I/O	Description
44	I-SPEANA_1	I	A/D input for spectrum analyser level display.
45	I-SPEANA_2	I	A/D input for spectrum analyser level display.
46	I-SPEANA_3	I	A/D input for spectrum analyser level display.
47	I-KEY 1	I	Key A/D input 1.
48	I-KEY 2	I	Key A/D input 2.
49	I-TU_SIG	I	Tuner RDS signal input. (Connected to GND through a resistor)
50	AVSS	–	GND.
51	O-BIAS	O	Bias output.
52	O-CD_CE	O	CD chip enable output.
53	O-CD_CLK	O	CD serial clock output.
54	O-CD_DATA	O	CD serial data output.
55	O-CLK	O	PLL clock output for LC72131D-N.
56 ~ 59	NC	–	Not connected.
60	I-CAM2	I	DECK2 cam switch input.
61	I-CAM1	I	DECK1 cam switch input.
62 ~ 70	P24 ~ P16	O	FL segment P24 ~ P16 output.
71	P15/AM 10K	I/O	FL segment P15 output / AM 10K data input to diode (not used).
72	P14/KARAOKE	I/O	FL segment P14 output / KARAOKE data input to diode (not used).
73	P13/LW	I/O	FL segment P13 output / LW data input to diode.
74	P12/SW	I/O	FL segment P12 output / SW data input to diode (not used).
75	P11/OIRT	I/O	FL segment P11 output / OIRT data input to diode (not used).
76	P10/FM WIDE	I/O	FL segment P10 output / FM WIDE data input to diode (not used).
77	P9/R+1	I/O	FL segment P9 output / R+1 data input to diode (not used).
78	P8/DEMO	I/O	FL segment P8 output / DEMO data input to diode (not used).
79	VDD2	–	Power supply input.
80	VLOAD	–	Power supply for FL display.
81	P7	O	FL segment P7 output.
82	P6/WITHOUT-ECO	I/O	FL segment P6 output / WITHOUT-ECO data input to diode .
83 ~ 87	P5 ~ P1	O	FL segment P5 ~ P1 output.
88 ~ 100	G1 ~ G13	O	FL grid G1 ~ G13 output.

MECHANICAL EXPLODED VIEW -1/1

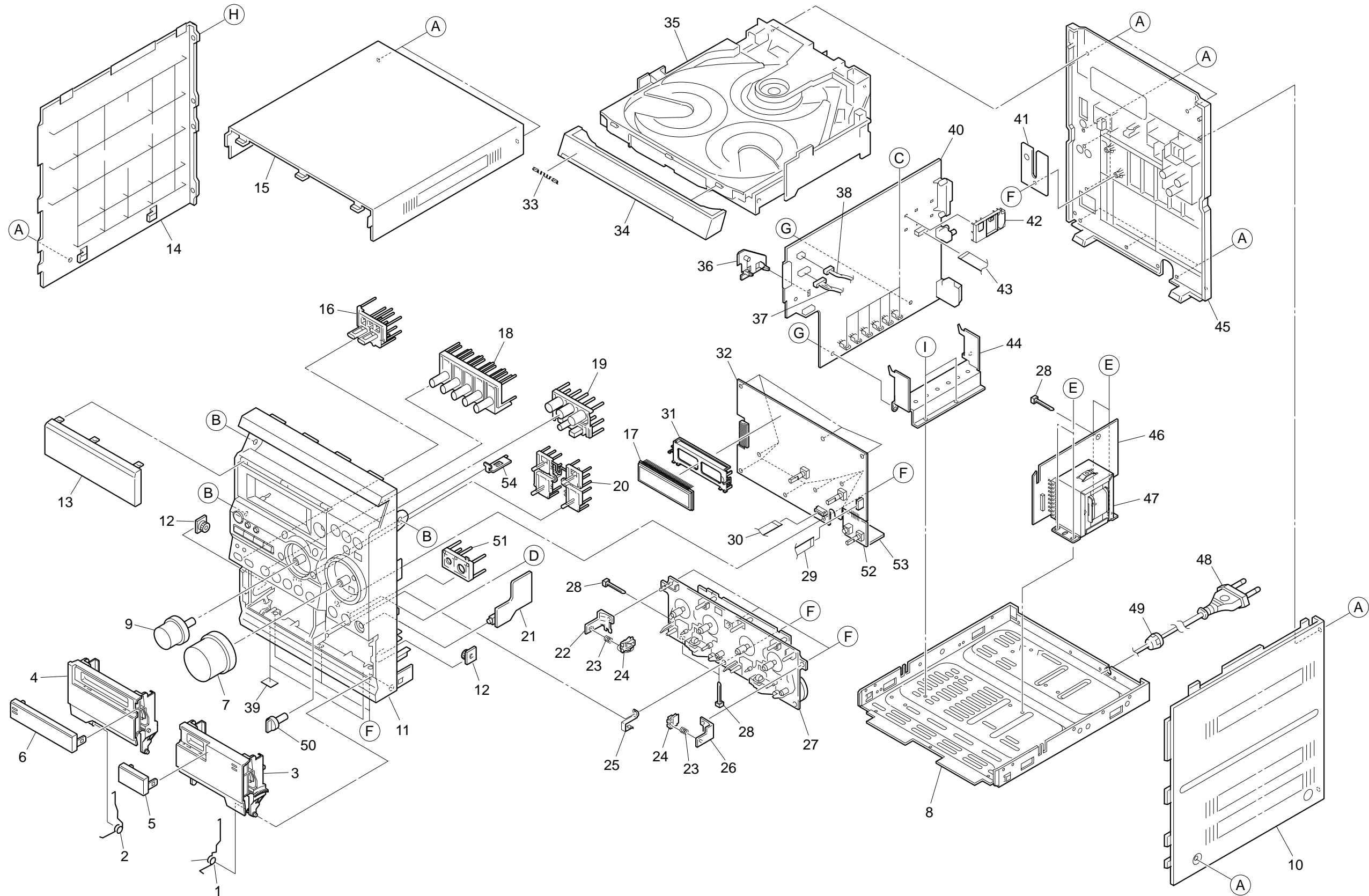

MECHANICAL PARTS LIST -1/1

! = SAFETY PARTS
 C = Components marked

All components used on this model at the production line are shown in this service manual.

However, please note that not all components will be available as spare parts for after-sales service.

Components marked S and O are designated as spare parts for service and will be stocked at the spare parts centers.

Components marked X and R are not designated as spare parts for after sales service, and will not be stocked at the spare parts centers.

UNIT-NAME	! C	REF-NO	PARTS-NO	PARTS-NAME	SUFFIX&MODEL
					CX-SNR14 LHSC2
	O	MC1001	8A-NF8-282-010	SPR-T, EJECT 2	a
	O	MC1002	8A-NF8-281-010	SPR-T, EJECT 1	a
	O	MC1003	8C-NFA-006-010	BOX, CASS 2	a
	O	MC1004	8C-NFA-005-010	BOX, CASS 1	a
	O	MC1005	8C-NF8-006-010	WINDOW, CASS 2	a
	O	MC1006	8C-NF8-005-010	WINDOW, CASS 1	a
	O	MC1007	8C-NF9-001-110	KNOB, RTRY VOL	a
	X	MC1008	8C-NF8-236-010	CHAS, MAIN CC 66-35 VCD	a
	O	MC1009	8C-NF8-027-010	KNOB, RTRY JOG	a
	O	MC1010	8C-NFA-032-010	PANEL, RIGHT	a
	O	MC1011	8C-NFA-011-110	CABI, ASSY FR H	a
	X	MC1011a	8C-NFA-008-010	KEY, POWER	a
	X	MC1011b	8C-NFA-018-010	PANEL, FR EZ	a
	X	MC1011c	8C-NFA-015-110	CABI, FR H	a
	O	MC1012	8Z-NF6-210-010	DMPR, 150 N	a
	O	MC1013	8C-NFA-041-010	WINDOW, DISP NR14	a
	O	MC1014	8C-NFA-031-010	PANEL, LEFT	a
	O	MC1015	8C-NFA-033-010	PANEL, TOP	a
	O	MC1016	8C-NF8-012-010	KEY, REC	a
	O	MC1017	8C-NF9-615-010	FL, HUA-13SS09T	a
					CX-SNR14 LHSC2
	O	MC1018	8C-NF8-013-110	KEY, OPE	a
	O	MC1019	8C-NF8-010-110	KEY, CD	a
	O	MC1020	8C-NF8-011-110	KEY, ENTER	a
	X	MC1021	8C-NHA-654-010	PWB, HP (FOR M/C MODEL) B/F	a
	O	MC1022	87-NF4-216-010	HLDR, LOCK 1	a
	O	MC1023	86-NF9-224-010	SPR-C, LOCK	a
	O	MC1024	82-NF5-229-010	PLATE, LOCK (*)	a
	X	MC1025	8C-NF9-201-010	PLATE, EARTH MECHA	a
	O	MC1026	87-NF4-217-110	HLDR, LOCK 2	a
	X	MC1027	M8-CZK-292-170	CMAT6Z2 (1+1) ALPS	a
	O	MC1028	87-A90-193-010	HLDR, CV100 (B)	a
	O	MC1029	88-908-301-110	FF-CABLE, 8P 1.25 300MM	a
	O	MC1030	88-911-101-110	FF-CABLE, 11P 1.25 100MM	a
	O	MC1031	8A-NFA-208-010	GUIDE, FL 100-25 ANFA	a
	X	MC1032	8C-NFA-621-010	PWB, FRONT CNF-A B/F	a
	O	MC1033	87-B00-002-010	BADGE, AIWA 30 ABS SIL	a
	O	MC1034	8C-NFA-009-010	PANEL, TRAY	a
	X	MC1035	M8-BZG-29R-070	BZG-2 ZD9GNC2	a
	O	MC1036	8A-NF8-206-010	HLDR, PWB M	a
	O	MC1037	8C-NF9-606-010	CONN ASSY, 8P -RPB	a
					CX-SNR14 LHSC2
	O	MC1038	8C-NF9-605-010	CONN ASSY, 3P -PB	a
	X	MC1039	8B-NF9-204-010	CUSH, 11-8.5-2	a
	X	MC1040	8C-NHA-651-010	PWB, MAIN CNH-A B/F	a
	X	MC1041	8C-NFA-623-010	PWB, HLDR WIRE CNF-A B/F	a
	X	MC1042	8B-ZA3-619-010	SHLD-CASE, BZA-3 EZ	a
	O	MC1043	88-906-251-110	FF-CABLE, 6P 1.25	a
	X	MC1044	8C-NHA-201-010	HT-SINK, TR VCD	a
	X	MC1044a	8C-NHA-202-010	HT-SINK, SUB C	a
	O	MC1045	8C-NFA-035-010	CABI, REAR LHSC NR14	a
	X	MC1046	8C-NHA-652-010	PWB, PT B/F	a
	!	MC1047	8C-NHA-601-010	PT, HR/HT CNH-A	a
	!	MC1048	87-A80-188-110	AC CORD ASSY, BRAZ BLK SUN FAI	a
	O	MC1049	87-085-185-010	BUSHING, AC CORD(E) CM-22B	a
	O	MC1050	8C-NFA-019-010	KNOB, RTRY MIC	a
	O	MC1051	8C-NFA-020-010	PLATE, MIC	a
	X	MC1052	8C-NFA-622-010	PWB, MIC CNF-A B/F	a
	X	MC1053	8C-NFA-624-010	PWB, HLDR MIC CNF-A B/F	a
	X	MC1054	8C-NF9-202-010	PLATE, EARTH MIC	a
	O	MC1A	87-B10-091-010	UTT2+3-10 W/O SLOT BLK	a
	O	MC1B	87-721-096-410	QT2+3-10 W/O SLOT	a
					CX-SNR14 LHSC2
	O	MC1C	87-067-001-010	S-SCREW, BVVWST2+3-12 W/O SLOT	a
	O	MC1D	88-AR1-217-010	S-SCREW, BFT2+3-8	a
	O	MC1E	87-078-200-010	S-SCREW, ITC+4-8 R	a
	O	MC1F	87-067-703-010	BVT2+3-10 W/O SLOT	a
	O	MC1G	87-NF4-224-010	S-SCREW, IT3B+3-8 CU	a
	O	MC1H	87-078-165-010	UTT2+3-6 W/O SLOT BLK	a
	O	MC1I	87-B10-315-010	BVIT3B+3-8 R W/O	a

COLOR NAME TABLE -1/1

Basic color symbol	Color	Basic color symbol	Color	Basic color symbol	Color
B	Black	C	Cream	D	Orange
G	Green	H	Gray	L	Blue
LT	Transparent Blue	N	Gold	P	Pink
R	Red	S	Silver	ST	Titan Silver
T	Brown	V	Violet	W	White
WT	Transparent White	Y	Yellow	YT	Transparent Yellow
LM	Metallic Blue	LL	Light Blue	GT	Transparent Green
LD	Dark Blue	DT	Transparent Orange	GM	Metallic Green
YM	Metallic Yellow	DM	Metallic Orange	PT	Transparent Pink
LA	Aqua Blue	GL	Light Green	HT	Transparent Gray
HM	Metallic Gray	NH	Champagne Gold	M	Wood Pattern

TAPE MECHANISM EXPLODED VIEW -1/1 <CMAT6Z2(1+1)ALPS>

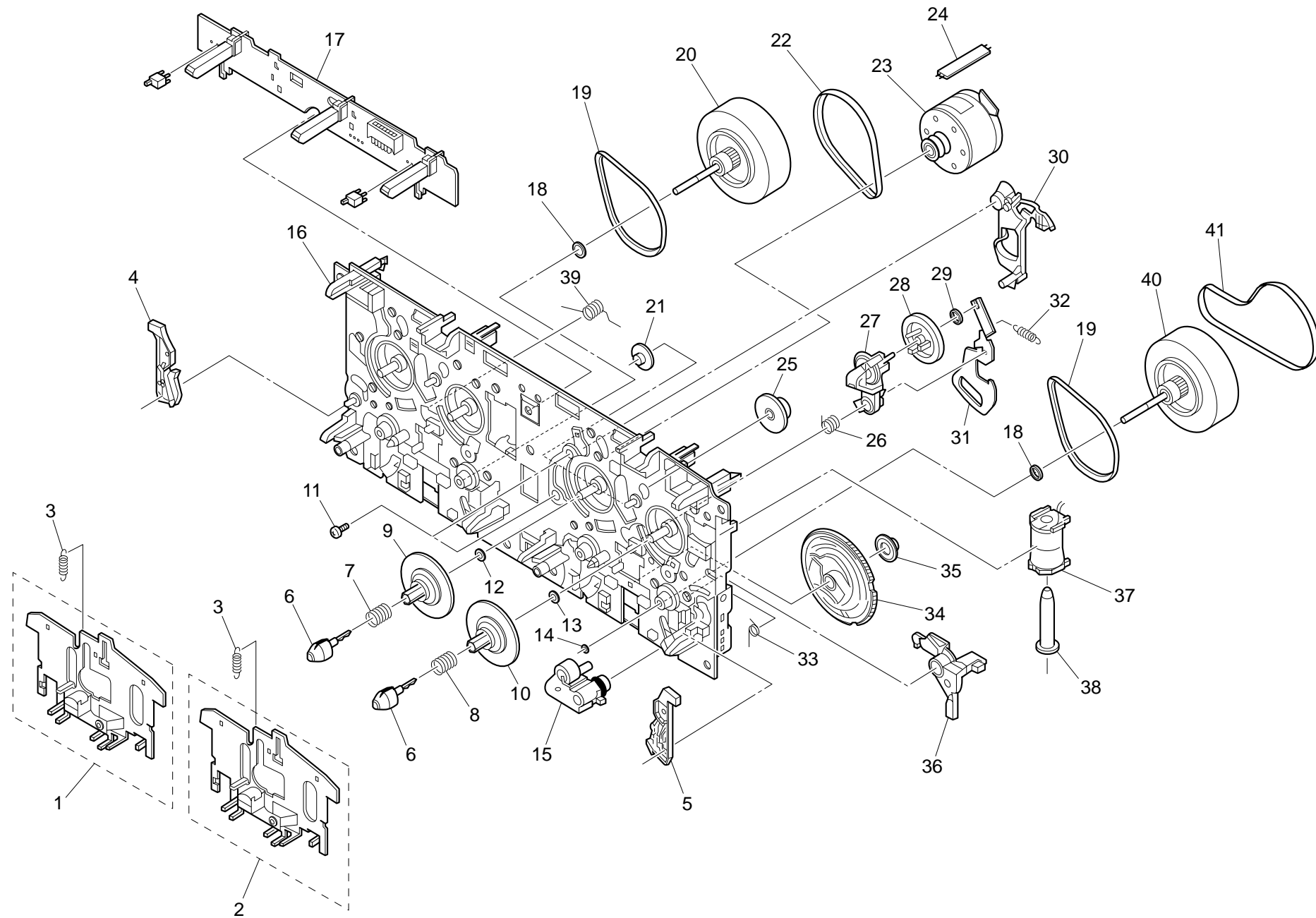

TAPE MECHANISM PARTS LIST -1/1 <CMAT6Z2(1+1)ALPS>

! = Δ SAFETY PARTS
 C = Components marked

All components used on this model at the production line are shown in this service manual.
 However, please note that not all components will be available as spare parts for after-sales service.
 Components marked S and O are designated as spare parts for service and will be stocked at the spare parts centers.
 Components marked X and R are not designated as spare parts for after sales service, and will not be stocked at the spare parts centers.

UNIT-NAME	! C	REF-NO	PARTS-NO	PARTS-NAME	SUFFIX&MODEL
CMAT6Z222A					
	O	ST1001	SF-513-889-000	PLATE HD BLK	a
	O	ST1002	SF-513-888-000	PLATE HD BLK	a
	O	ST1003	SF-K32-T32-000	SPRING HB	a
	O	ST1004	SF-D58-H13-000	ARM INTERLOCK L	a
	O	ST1005	SF-D58-K13-000	ARM INTERLOCK R	a
	O	ST1006	SF-D53-M51-000	REEL FEATHER	a
	O	ST1007	SF-K32-U12-000	SP REEL (L)	a
	O	ST1008	SF-K32-V12-000	SP REEL (R)	a
	O	ST1009	SF-D56-GS3-000	REEL BASE	a
	O	ST1010	SF-D52-W51-000	REEL BASE	a
	O	ST1011	SF-G11-414-000	SCREW, PAN SW 2.6X5 ZN	a
	O	ST1012	SF-J11-131-000	PW, 4.1X0.13	a
	O	ST1013	SF-J11-135-000	PW, 4.1X0.25	a
	O	ST1014	SU-J16-F11-000	PW, 1.75X0.4	a
	O	ST1015	SF-514-131-000	ROLLER PINCH R BLK	a
	O	ST1016	SF-612-252-000	CHASSIS BASE BLK	a
	O	ST1017	SF-567-700-000	PWB CONTROL BLK	a
	O	ST1018	SF-J11-130-000	PW, 2.6X0.25	a
	O	ST1019	SF-F19-S31-000	F/R BELT	a
	O	ST1020	SF-R26-C11-000	ASSY F/W	a
CMAT6Z222A					
	O	ST1021	SF-D53-K52-000	PLAY GEAR (A)	a
	O	ST1022	SF-F19-N22-000	MAIN BELT	a
	O	ST1023	SF-525-349-000	MTR MAIN BLK	a
	X	ST1024	SW-G58-H03-000	2 CORE JUMPER LEAD	a
	O	ST1025	SF-D60-L12-000	FF GEAR (E)	a
	O	ST1026	SF-K35-K14-000	CAM SP	a
	O	ST1027	SF-522-063-000	CLUTCH ASSY BLK	a
	O	ST1028	SF-D60-B15-000	PULLEY F/R	a
	O	ST1029	SF-J11-117-000	WASHER 1.7X0.25	a
	O	ST1030	SF-D58-T12-000	LEVER BRAKE	a
	O	ST1031	SF-C65-W21-000	LEVER F/R	a
	O	ST1032	SF-K35-E14-000	SP ARM F/R	a
	O	ST1033	SF-K32-R21-000	SP ARM PLAY	a
	O	ST1034	SF-D61-C14-000	CAM GEAR	a
	O	ST1035	SF-D59-F12-000	BUSH	a
	O	ST1036	SF-D58-P15-000	ARM PLAY	a
	O	ST1037	SF-765-295-000	SOLENOID BLK	a
	O	ST1038	SF-L41-S22-000	PLANGER	a
	O	ST1039	SF-K34-Y11-000	B/C SP	a
	O	ST1040	SF-R26-D11-000	ASSY F/W	a
CMAT6Z222A					
	O	ST1041	SF-F19-N31-000	MAIN BELT	a

GENERAL SPEAKER DISASSEMBLY INSTRUCTIONS (FOR REFERENCE) -1/1

Type.1

Insert a flat-bladed screwdriver into the position indicated by the arrows and remove the panel. Remove the screws of each speaker unit and then remove the speaker units.

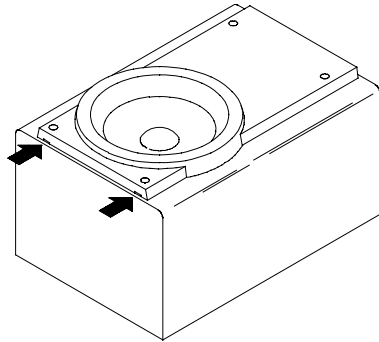

Type.2

Remove the grill frame and four pieces of rubber caps by pulling out with a flat-bladed screwdriver. Remove the screws from hole where installed rubber caps. Insert a flat-bladed screwdriver into the position indicated by the arrows and remove the panel. Remove the screws of each speaker unit and then remove the speaker units.

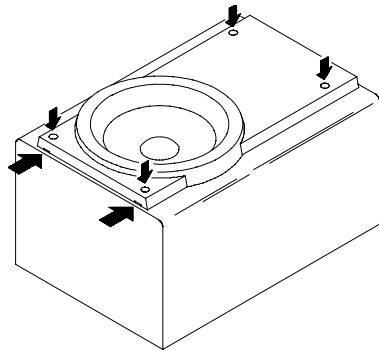

Type.3

Insert a flat-bladed screwdriver into the position indicated by the arrows and remove the panel. Turn the speaker unit to counter-clockwise direction while inserting a flat-bladed screwdriver into one of the hollows around speaker unit, and then remove the speaker unit. After replacing the speaker unit, install it turning to clockwise direction until "click" sound comes out.

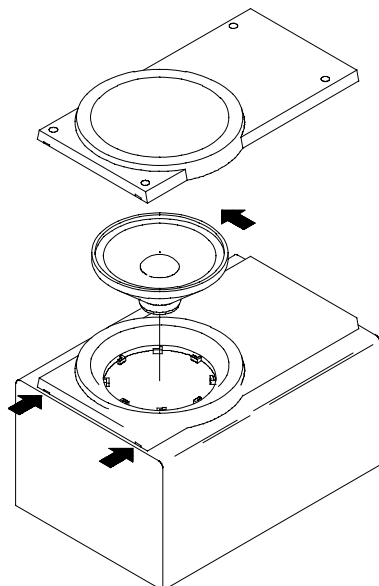

Type.4

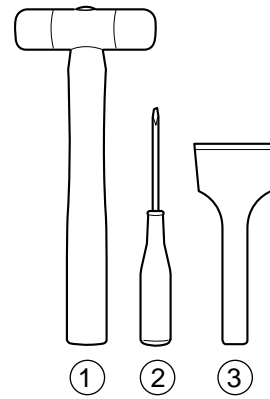

TOOLS

- ① Plastic head hammer
- ② (⊖) flat head screwdriver
- ③ Cut chisel

How to Remove the PANEL, FR

1. Insert the (⊖) flat head screwdriver tip into the gap between the PANEL, FR and the PANEL, SPKR. Tap the head of the (⊖) flat head screwdriver with the plastic hammer head, and create the clearance as shown in Fig-1.
2. Insert the cut chisel in the clearance, and tap the head of the cut chisel with plastic hammer as shown in Fig-2, to remove the PANEL, FR.
3. Place the speaker horizontally. Tap head of the cut chisel with plastic hammer as shown in Fig-3, and remove the PANEL, FR completely.

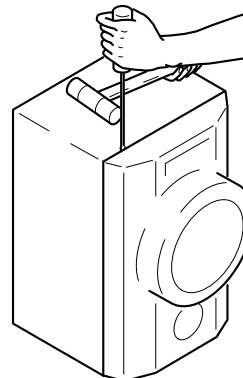

Fig-1

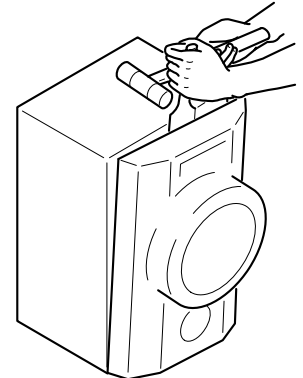

Fig-2

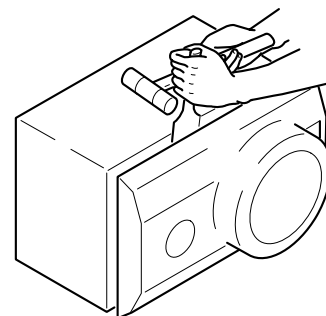

Fig-3

How to Attach the PANEL, FR

Attach the PANEL, FR to the PANEL, SPKR. Tap the four corners of the PANEL, FR with the plastic hammer to fit the PANEL, FR into the PANEL, SPKR completely.

SPEAKER PARTS LIST -1/1 <SX-NR22>

! = Δ SAFETY PARTS

C = Components marked

All components used on this model at the production line are shown in this service manual.

However, please note that not all components will be available as spare parts for after-sales service.

Components marked S and O are designated as spare parts for service and will be stocked at the spare parts centers.

Components marked X and R are not designated as spare parts for after sales service, and will not be stocked at the spare parts centers.

UNIT-NAME	! C	REF-NO	PARTS-NO	PARTS-NAME	SUFFIX&MODEL
					SX-SNR22
					YLS1N
	O	SP1001	8A-NSJ-006-010	BADGE,AIWA S35	a
	O	SP1002	8C-CP5-007-010	CORD,SPKR O	a
	O	SP1003	8C-CP5-008-010	CORD,BUSH O	a
	O	SP1004	8C-NS9-007-010	PANEL,DUCT O	a
	O	SP1005	8C-NS9-008-010	GRILLE,FRAME ASSY O	a
	X	SP1006	8C-NS9-009-010	GRILLE,FRAME O	a
	O	SP1007	8C-NS9-012-010	ADAPTOR,W O	a
	X	SP1008	8C-NS9-015-010	NET,	a
	X	SP1009	8C-NS9-033-010	CABI,	a
	O	SP1010	8C-NS9-602-010	SPKR, CERAMIC ASSY 60	a
	O	SP1011	8C-NSK-002-010	PANEL,FR	a
	X	SP1012	8C-NSK-003-010	LBL,SPEC YL	a
	O	SP1013	8C-NSK-602-010	SPKR, 120/20	a
	X	SP1014	8C-NSK-852-010	CUSHION,ASSY SOZ 2	a

OTHER PARTS LIST -1/1

- ! = Δ SAFETY PARTS
- C = Components marked

All components used on this model at the production line are shown in this service manual.
 However, please note that not all components will be available as spare parts for after-sales service.
 Components marked S and O are designated as spare parts for service and will be stocked at the spare parts centers.
 Components marked X and R are not designated as spare parts for after sales service, and will not be stocked at the spare parts centers.

UNIT-NAME	! C	REF-NO	PARTS-NO	PARTS-NAME	SUFFIX&MODEL
					CX-SNR14
					LHSC2
	X		87-B40-098-010	BAG, PV 0.025-650-750 PL	a
	X		8C-NFA-851-010	CUSHION, FRONT BFC	a
	X		8C-NFA-852-010	CUSHION, REAR BFC	a
	X		92-370-716-010	SH, FOAMED-MAT 0.31-700-500	a
	X		87-B40-085-010	BAG, PV 0.04-200-350 PL	a
	X		87-B50-056-010	SH, CAUTION AC VOLTAGE	a
	X		8C-NFA-978-010	LBL, POP HTR	a
	X		8C-NFA-981-010	LBL, POP LHL2	a
	X		87-B40-281-010	LBL, BAR-CODE A 35X8	a
	X		87-057-995-010	LBL, CAUTION EFSD	a
	X		87-057-961-010	LBL, CAUTION TRIANGLE	a
	X		8C-NF8-045-010	SH, FL	a

アイワ株式会社 〒110-8710 東京都台東区池之端1-2-11 ☎03(3827)3111 (代表)
AIWA CO.,LTD. 2-11, IKENOHATA 1-CHOME, TAITO-KU, TOKYO 110-8710, JAPAN TEL:03 (3827) 3111

0251431