

SERVICE MANUAL

CD STEREO SYSTEM

BASIC CD MECHANISM : BZG-2 ZD5GNC
BASIC TAPE MECHANISM : ZZM-3 YPR4NC

SYSTEM	CD CASSEIVER	SPEAKER	REMOTE CONTROLLER
NSX-R41	CX-NR41	SX-NR40	RC-CAS10

If requiring information about the CD mechanism, see Service Manual of BZG-2, (S/M Code No. 09-023-353-2N8),

aiwa

S/M Code No. 09-027-453-4N3



TABLE OF CONTENTS -1/1

SPECIFICATIONS	3
PROTECTION OF EYES FROM LASER BEAM DURING SERVICING	4
NOTE ON BEFORE STARTING REPAIR	5, 6
ACCESSORIES PARTS LIST	7
ELECTRICAL PARTS LIST	8 ~ 22
TRANSISTOR ILLUSTRATION	23
SCHEMATIC DIAGRAM -1/5 (MAIN-1/2, AMP SECTION)	24
SCHEMATIC DIAGRAM -2/5 (MAIN-2/2, TUNER SECTION)	25
SCHEMATIC DIAGRAM -3/5 (HP SECTION)	26
WIRING -1/4 (MAIN C.B, HP C.B)	27
SCHEMATIC DIAGRAM -4/5 (FRONT/DECK SECTION)	28
WIRING -2/4 (FRONT C.B/MIC C.B)	29
WIRING -3/4 (DECK C.B)	30
SCHEMATIC DIAGRAM -5/5 (PT SECTION)	31
WIRING -4/4 (PT C.B)	32
ELECTRICAL ADJUSTMENT	33 ~ 39
CD TEST MODE	40
FL DISPLAY (BJ854GNK BNF-1)	41 ~ 42
IC BLOCK DIAGRAM	43 ~ 44
IC DESCRIPTION	45 ~ 46
MECHANICAL EXPLODED VIEW	47
MECHANICAL PARTS LIST	48
COLOR NAME TABLE	49
TAPE MECHANISM EXPLODED VIEW <ZMZ-3 YPR4NC>	50
TAPE MECHANISM PARTS LIST <ZMZ-3 YPR4NC>	51 ~ 52
GENERAL SPEAKER DISASSEMBLY INSTRUCTIONS (FOR REFERENCE)	53
SPEAKER PARTS LIST (SX-NR40)	54
OTHER PARTS LIST	55 ~ 56

SPECIFICATIONS -1/1

MAIN UNIT CX-NR41

TUNER

FM tuning range	87.5 MHz to 108 MHz
FM usable sensitivity (IHF)	16.8 dBf
FM antenna terminal	75 ohms (unbalanced)
MW tuning range	531 kHz to 1602 kHz (9 kHz step) 530 kHz to 1710 kHz (10 kHz step)
MW usable sensitivity	350 μ V/m
LW tuning range	144 kHz to 290 kHz
LW usable sensitivity	1400 μ V/m
MW/LW antenna	Loop antenna

AMPLIFIER

Power output	Rated: 48 W + 48 W (6 ohms, T.H.D. 1 %, 1 kHz/DIN 45500) Reference: 60 W + 60 W (6 ohms, T.H.D. 10 %, 1 kHz/DIN 45324) DIN MUSIC POWER: 155 W + 155 W
Total harmonic distortion	0.08 % (24 W, 1 kHz, 6 ohms, DIN AUDIO)
Input	VIDEO/AUX: 500 mV
Outputs	SPEAKERS: 6 ohms or more PHONES: 32 ohms or more

CASSETTE DECK

Track format	4 tracks, 2 channels stereo
Frequency response	50 Hz - 15 kHz
Recording system	AC bias
Heads	DECK 1: playback x 1 DECK 2: recording/playback x 1, erase x 1

CD PLAYER

Laser	Semiconductor laser ($\lambda= 780$ nm)
D/A converter	1 bit dual
Signal-to-noise ratio	85 dB (1 kHz, 0 dB)
Harmonic distortion	0.05 % (1 kHz, 0 dB)

GENERAL

Power requirements	230 V AC, 50 Hz
Power consumption	77 W
Power consumption in standby mode	With ECO mode on: 0.6 W With ECO mode off: 16 W
Dimensions (W x H x D)	260 x 324 x 315 mm
Weight	6.2 kg

FRONT SPEAKERS SX-NR40

Speaker system	3 way, bass reflex (magnetic shielded)
Speaker units	Woofer: 160 mm cone Tweeter: 60 mm cone Super tweeter: 20 mm ceramic x 2
Impedance	6 ohms
Dimensions (W x H x D)	230 x 324 x 227 mm
Weight	3.5 kg

Specifications and external appearance are subject to change without notice.

COPYRIGHT

Check copyright laws relevant to recordings from discs, radio or tape for the country where the unit is to be used.

PROTECTION OF EYES FROM LASER BEAM DURING SERVICING -1/1

This set employs laser. Therefore, be sure to follow carefully the instructions below when servicing.

WARNING!!

WHEN SERVICING, DO NOT APPROACH THE LASER EXIT WITH THE EYE TOO CLOSELY. IN CASE IT IS NECESSARY TO CONFIRM LASER BEAM EMISSION. BE SURE TO OBSERVE FROM A DISTANCE OF MORE THAN 30cm FROM THE SURFACE OF THE OBJECTIVE LENS ON THE OPTICAL PICK-UP BLOCK.

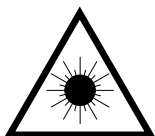

- Caution: Invisible laser radiation when open and interlocks defeated avoid exposure to beam.
- Advarsel: Usynlig laserstråling ved åbning, når sikkerhedsafbrydere er ude af funktion. Undgå udsættelse for stråling.

VAROITUS!

Laiteen Käyttäminen muulla kuin tässä käyttöohjeessa mainitulla tavalla saattaa altistaa käyttäjän turvallisuusluokan 1 ylittävälle näkymättömälle lasersäteilylle.

WARNING!

Om apparaten används på annat sätt än vad som specificeras i denna bruksanvisning, kan användaren utsättas för osynlig laserstråling, som överskrider gränsen för laserklass 1.

CAUTION

Use of controls or adjustments or performance of procedures other than those specified herein may result in hazardous radiation exposure.

ATTENTION

L'utilisation de commandes, réglages ou procédures autres que ceux spécifiés peut entraîner une dangereuse exposition aux radiations.

ADVARSEL

Usynlig laserstråling ved åbning, når sikkerhedsafbrydere er ude af funktion. Undgå udsættelse for stråling.

This Compact Disc player is classified as a CLASS 1 LASER product.

The CLASS 1 LASER PRODUCT label is located on the rear exterior.

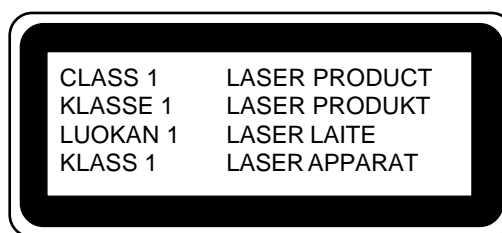

Precaution to replace Optical block

(KSM213RSCM)

Body or clothes electrostatic potential could ruin laser diode in the optical block. Be sure ground body and workbench, and use care the clothes do not touch the diode.

- 1) After the connection, remove solder shown in right figure.

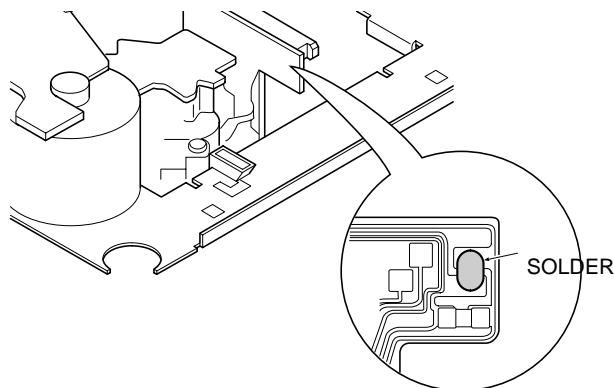

NOTE ON BEFORE STARTING REPAIR -1/2

1. Forced discharge of electrolytic capacitor of power supply block

When repair is going to be attempted in the set that uses relay circuit in the power supply block, electric potential is kept charged across the electrolytic capacitors (C101, 102) even though AC power cord is removed. If repair is attempted in this condition, secondary defect can occur. In order to prevent the secondary trouble, perform the following measures before starting repair work.

Discharge procedure

- ① Remove the AC power cord.
- ② Connect a discharging resistor at an end of lead wire that has clips at both ends. Connect the other end of the lead wire to metal chassis.
- ③ Contact the other end of the discharging resistor to the positive (+) side (+VH) of C101. (For two seconds)
- ④ Contact the same end of the discharging resistor as step ③ to the negative (-) side (-VH) of C102 in the same way. (For two seconds)
- ⑤ Check that voltage across C101 and C102 has decreased to 1 V or less using a multimeter or an oscilloscope.

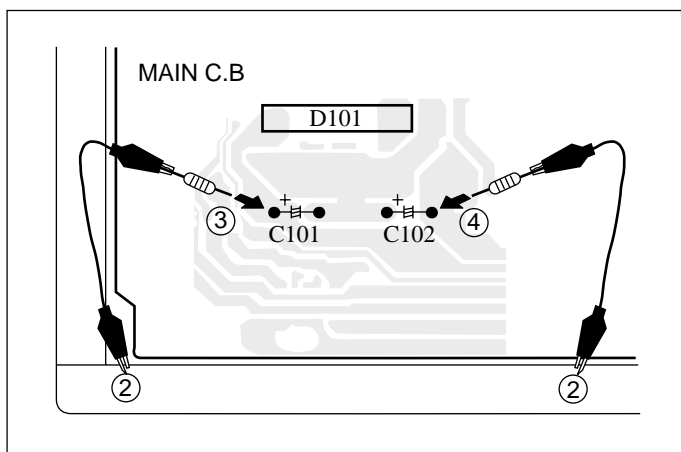

Fig-1

Select a discharging resistor referring to the following table.

Charging voltage (V) (C101, 102)	Discharging resistor (Ω)	Rated power (W)	Parts number
25-48	100	3	87-A00-247-090
49-140	220	5	87-A00-232-090

Note: The reference numbers (C101, C102) of the electrolytic capacitors can change depending on the models. Be sure to check the reference numbers of the charging capacitors on schematic diagram before starting the discharging work.

2. Check items before exchanging the MICROCOMPUTER

Be sure to check the following items before exchanging the MICROCOMPUTER. Exchange the MICROCOMPUTER after confirming that the MICROCOMPUTER is surely defective.

2-1. Regarding the HOLD terminal of the MICROCOMPUTER

When the HOLD terminal (INPUT) of the MICROCOMPUTER is "H", the MICROCOMPUTER is judged to be operating correctly.

When this terminal is "L", the main power cannot be turned on. Therefore, be sure to check the terminal voltage of the HOLD terminal before exchange.

When the MICROCOMPUTER is not defective, the HOLD terminal can also go "L" when the POWER AMPLIFIER has any abnormalities that triggers the abnormality detection circuit on the MAIN C. B. that sets the HOLD terminal to "L".

• Good or no good judgement of the MICROCOMPUTER

- ① Turn on the AC main power.
- ② Confirm that the main power is turned on and the HOLD terminal of the MICROCOMPUTER keeps the "H" level or not.
- ③ When the HOLD terminal is "L" level, the abnormality detection circuit is judged to be working correctly and the MICROCOMPUTER is judged to be good.

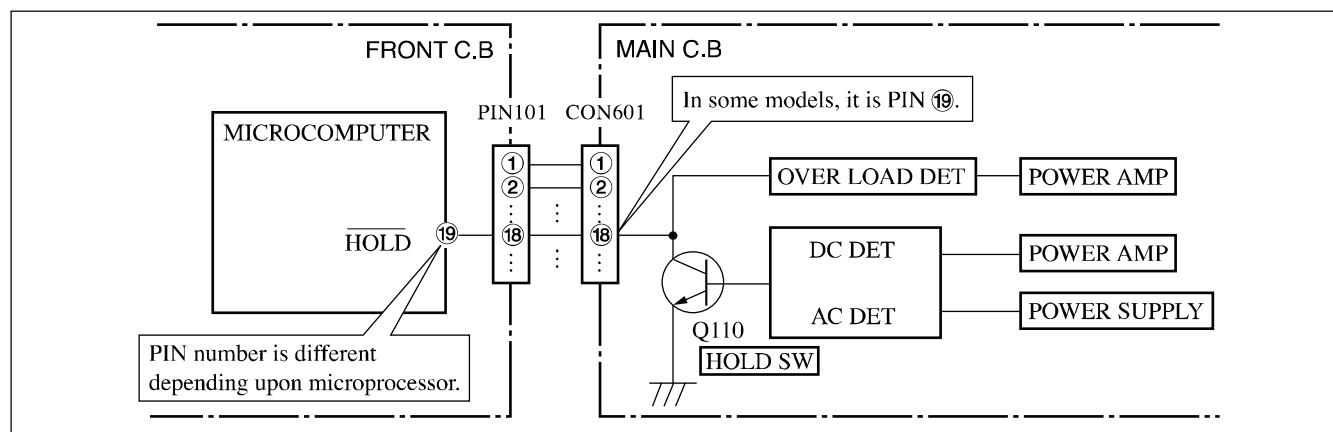

Fig-2-1

NOTE ON BEFORE STARTING REPAIR -2/2

In such a case, check also if the POWER AMPLIFIER circuit or power supply circuit has any abnormalities or not.

2-2. Regarding reset

There are cases that the machine does not work correctly because the MICROCOMPUTER is not reset even though the AC power cord is re-inserted, or the software reset (pressing the STOP key + POWER key) is performed.

When the above described phenomenon occurs, it can lead to wrong judgement as if the MICROCOMPUTER is defective and to exchange the MICROCOMPUTER. In such a case, perform the forced-reset by the following procedure and check good or no good of the MICROCOMPUTER.

- ① Remove the AC power cord.

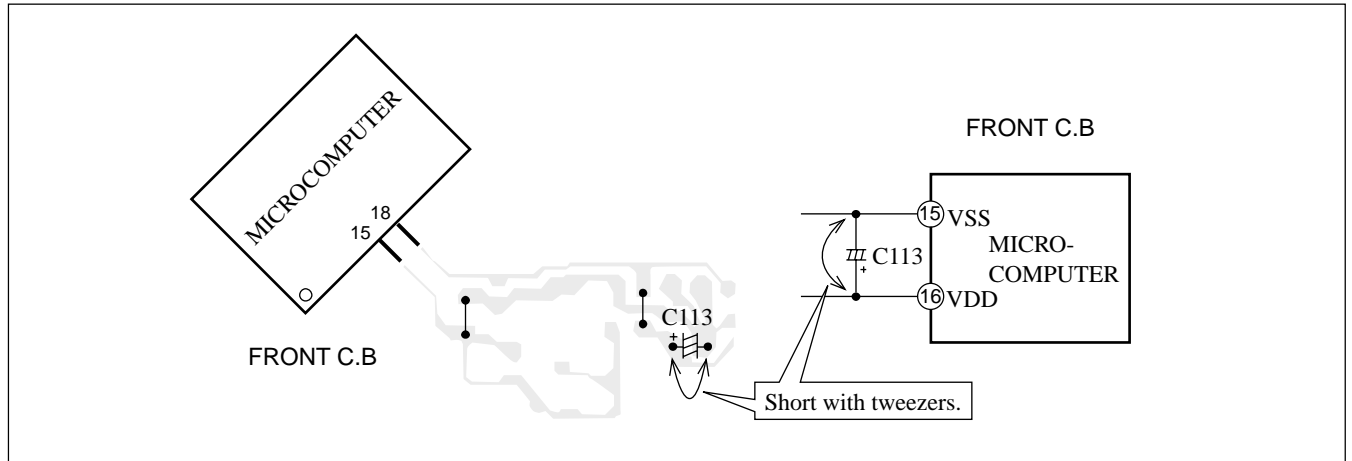

Fig-2-2

- ② Short both ends of the electrolytic capacitor C113 that is connected to VDD of the MICROCOMPUTER with tweezers.
- ③ Connect the AC power cord again. If the MICROCOMPUTER returns to the normal operation, the MICROCOMPUTER is good.

Note: The reference number or MICROCOMPUTER pin number of transistor (Q110) and electrolytic capacitor (C113) can change depending on the models. Be sure to check the reference numbers on schematic diagram before starting the discharging work.

2-3. Confirmation of soldering state of MICROCOMPUTER

Check the soldering state of the MICROCOMPUTER in addition to the above described procedures. Be sure to exchange the MICROCOMPUTER after surely confirming that the trouble is not caused by poor soldering but the MICROCOMPUTER itself.

ACCESSORIES PARTS LIST -1/1

! = Δ SAFETY PARTS

C = Components marked

All components used on this model at the production line are shown in this service manual.

However, please note that not all components will be available as spare parts for after-sales service.

Components marked S and O are designated as spare parts for service and will be stocked at the spare parts centers.

Components marked X and R are not designated as spare parts for after sales service, and will not be stocked at the spare parts centers.

UNIT-NAME	! C	REF-NO	PARTS-NO	PARTS-NAME	SUFFIX&MODEL
					CX-SNR41
					EZSC
	O	AS1001	8C-NF7-906-010	IB,EZ(9L)FM NSX-R41	a
	X	AS1002	8C-NF8-703-010	RC UNIT,RC-CAS10(SMK)	a
	O	AS1003	87-A92-150-010	ANT,LOOP AM NO-CONT	a
	X	AS1004	87-A92-346-010	ANT,WIRE FM(FASTEN)	a

ELECTRICAL PARTS LIST - 1/15

! = SAFETY PARTS
 C = Components marked

All components used on this model at the production line are shown in this service manual.
 However, please note that not all components will be available as spare parts for after-sales service.
 Components marked S and O are designated as spare parts for service and will be stocked at the spare parts centers.
 Components marked X and R are not designated as spare parts for after sales service, and will not be stocked at the spare parts centers.

UNIT-NAME	! C	REF-NO	PARTS-NO	PARTS-NAME	SUFFIX&MODEL
					CX-SNR41 EZSC
DECK	O	CN 0001	87-A61-462-010	CONN,11P H D125 SRA	a
DECK	X	CRD0001	82-ZM3-601-010	RBN-CORD,4P-75	a
DECK	S	IC 0001	87-A21-269-010	IC,EW732	a
DECK	S	IC 0002	87-A21-269-010	IC,EW732	a
DECK	X	R 0001	88-121-392-080	RES,3.9K-1/8W J	a
DECK	O	SFR0001	87-024-581-010	SFR,3.3K H KVSF637A	a
DECK	O	SOL0001	82-ZM3-621-210	SOL ASSY,27 KO	a
DECK	O	SOL0002	82-ZM3-621-210	SOL ASSY,27 KO	a
DECK	O	SW 0001	87-036-109-010	SW,MICRO SPPB61	a
DECK	O	SW 0002	87-036-109-010	SW,MICRO SPPB61	a
DECK	O	SW 0003	87-036-109-010	SW,MICRO SPPB61	a
DECK	O	SW 0004	87-036-109-010	SW,MICRO SPPB61	a
DECK	O	SW 0005	87-036-109-010	SW,MICRO SPPB61	a
FRONT	O	C 0108	87-010-785-080	C-CAP,U 0.015-25 K B GRM	a
FRONT	O	C 0153	87-010-787-080	C-CAP,U 0.022-25 K B GRM	a
FRONT	O	C 0154	87-010-246-040	CAP,E 47-35 M 11L SME	a
FRONT	O	C 0155	87-010-404-040	CAP,E 4.7-50 M 11L SME	a
FRONT	O	C 0156	87-010-404-040	CAP,E 4.7-50 M 11L SME	a
FRONT	O	C 0301	87-012-278-080	C-CAP,U 2200P-50 K B GRM	a
FRONT	O	C 0351	87-A10-353-080	C-CAP,U 0.22-10 K B	a
					CX-SNR41 EZSC
FRONT	O	C 0361	87-012-274-080	C-CAP,U 1000P-50 K B GRM	a
FRONT	O	C 0362	87-012-274-080	C-CAP,U 1000P-50 K B GRM	a
FRONT	O	C 0371	87-012-274-080	C-CAP,U 1000P-50 K B GRM	a
FRONT	O	C 0372	87-012-274-080	C-CAP,U 1000P-50 K B GRM	a
FRONT	O	C 0601	87-010-382-040	CAP,E 22-25 M 11L SME	a
FRONT	O	C 0801	87-A10-353-080	C-CAP,U 0.22-10 K B	a
FRONT	O	C 0803	87-012-280-080	C-CAP,U 3300P-50 K B GRM	a
FRONT	O	C 0804	87-A10-592-080	C-CAP,S 0.015-50 J B	a
FRONT	O	C 0806	87-012-273-080	C-CAP,U 820P-50 K B GRM	a
FRONT	O	C 0808	87-010-544-040	CAP,E 0.1-50 M 11L SME	a
FRONT	O	C 0809	87-010-404-040	CAP,E 4.7-50 M 11L SME	a
FRONT	O	C 0810	87-010-759-080	C-CAP,U 0.1-25 Z F CM/CB	a
FRONT	O	C 0811	87-A12-052-080	C-CAP,S 0.033-25 J B	a
FRONT	O	C 0812	87-012-285-080	C-CAP,U 8200P-50 K B GRM	a
FRONT	O	C 0901	87-012-195-080	C-CAP,U 100P-50 J CH GRM	a
FRONT	O	C 0902	87-012-195-080	C-CAP,U 100P-50 J CH GRM	a
FRONT	O	C 0903	87-012-195-080	C-CAP,U 100P-50 J CH GRM	a
FRONT	O	C 0904	87-012-195-080	C-CAP,U 100P-50 J CH GRM	a
FRONT	O	C 0905	87-012-195-080	C-CAP,U 100P-50 J CH GRM	a
FRONT	O	C 0906	87-012-195-080	C-CAP,U 100P-50 J CH GRM	a
					CX-SNR41 EZSC
FRONT	O	C 0907	87-012-195-080	C-CAP,U 100P-50 J CH GRM	a
FRONT	O	C 0908	87-012-195-080	C-CAP,U 100P-50 J CH GRM	a
FRONT	O	C 0909	87-012-195-080	C-CAP,U 100P-50 J CH GRM	a
FRONT	O	C 0910	87-012-195-080	C-CAP,U 100P-50 J CH GRM	a
FRONT	O	C 0911	87-012-274-080	C-CAP,U 1000P-50 K B GRM	a
FRONT	O	C 0912	87-010-759-080	C-CAP,U 0.1-25 Z F CM/CB	a
FRONT	O	C 0913	87-A10-189-040	CAP,E 220-10 M 5L	a
FRONT	O	C 0915	87-010-759-080	C-CAP,U 0.1-25 Z F CM/CB	a
FRONT	O	C 0916	87-010-759-080	C-CAP,U 0.1-25 Z F CM/CB	a
FRONT	O	C 0917	87-010-759-080	C-CAP,U 0.1-25 Z F CM/CB	a
FRONT	O	C 0919	87-012-286-080	C-CAP,U 0.01-25 K B GRM	a
FRONT	O	C 0920	87-010-829-080	C-CAP,U 0.047-16 Z F CM/CB	a
FRONT	O	C 0921	87-012-282-080	C-CAP,U 4700P-50 K B GRM	a
FRONT	O	C 0922	87-012-195-080	C-CAP,U 100P-50 J CH GRM	a
FRONT	O	C 0923	87-016-116-080	C-CAP,U 0.015-25 J B CB	a
FRONT	O	C 0924	87-016-116-080	C-CAP,U 0.015-25 J B CB	a
FRONT	O	C 0925	87-016-116-080	C-CAP,U 0.015-25 J B CB	a
FRONT	O	C 0951	87-012-172-080	C-CAP,U 10P-50 D CH GRM	a
FRONT	O	C 0952	87-010-854-080	C-CAP,S 560P-50 J CH CMC	a
FRONT	O	C 0953	87-012-349-080	C-CAP,S 1000P-50 J CH GRM	a
					CX-SNR41 EZSC
FRONT	O	C 0961	87-A12-075-040	CAP,E 10-35 SMG	a
FRONT	O	C 0962	87-012-336-080	C-CAP,U 330P-50 J SL GRM	a
FRONT	O	C 0963	87-010-759-080	C-CAP,U 0.1-25 Z F CM/CB	a
FRONT	O	CN 0104	87-099-013-010	CONN,11P V BLK 6216	a
FRONT	O	CN 0701	87-099-720-010	CONN,30P BLK TYK-B(P)	a
FRONT	O	CN 0731	87-099-196-010	CONN,8P V BLK 6216	a
FRONT	S	D 0103	87-020-465-080	DIODE,1SS133	a
FRONT	S	D 0104	87-020-465-080	DIODE,1SS133	a
FRONT	S	D 0301	87-A40-234-080	ZENER,MTZJ5.6A	a
FRONT	S	D 0302	87-020-465-080	DIODE,1SS133	a
FRONT	S	D 0601	87-A40-269-080	C-DIODE,MC2836	a
FRONT	S	D 0655	87-A40-269-080	C-DIODE,MC2836	a
FRONT	S	D 0656	87-A40-269-080	C-DIODE,MC2836	a
FRONT	S	D 0657	87-A40-269-080	C-DIODE,MC2836	a
FRONT	S	D 0658	87-A40-269-080	C-DIODE,MC2836	a
FRONT	S	D 0659	87-A40-269-080	C-DIODE,MC2836	a
FRONT	S	D 0801	87-020-465-080	DIODE,1SS133	a
FRONT	S	D 0983	87-020-465-080	DIODE,1SS133	a
FRONT	O	FFC0104	88-911-101-110	FF-CABLE,11P 1.25 100MM	a
FRONT	O	FFC0731	88-908-301-110	FF-CABLE,8P 1.25 300MM	a

ELECTRICAL PARTS LIST - 2/15

! = SAFETY PARTS
 C = Components marked

All components used on this model at the production line are shown in this service manual.
 However, please note that not all components will be available as spare parts for after-sales service.
 Components marked S and O are designated as spare parts for service and will be stocked at the spare parts centers.
 Components marked X and R are not designated as spare parts for after sales service, and will not be stocked at the spare parts centers.

UNIT-NAME	! C	REF-NO	PARTS-NO	PARTS-NAME	SUFFIX&MODEL
					CX-SNR41
					EZSC
FRONT	O	FL 0901	8B-NF1-610-010	FL,BJ854GNK BNF-1	a
FRONT	S	IC 0901	8C-NF7-646-030	C-IC,UPD780228GF-087-3BA	a
FRONT	S	IC 0961	87-A21-218-110	IC,NJL64H380A	a
FRONT	O	L 0951	87-A50-655-010	COIL,CLK 4.19MHZ (TOKO)7KLY	a
FRONT	O	LED0201	87-A41-062-040	LED,LTL-1CHEE-012A RED	a
FRONT	O	LED0202	87-A41-120-040	LED,SEL6810ATP5 UMB	a
FRONT	O	LED0203	87-A41-120-040	LED,SEL6810ATP5 UMB	a
FRONT	O	LED0204	87-A41-120-040	LED,SEL6810ATP5 UMB	a
FRONT	S	Q 0102	87-A30-076-080	C-TR,2SC3052F	a
FRONT	S	Q 0104	87-A30-538-040	C-TR,SRA2202S	a
FRONT	S	Q 0301	87-A30-494-080	TR,2SA1980G	a
FRONT	S	Q 0302	87-A30-076-080	C-TR,2SC3052F	a
FRONT	S	Q 0303	87-A30-076-080	C-TR,2SC3052F	a
FRONT	S	Q 0601	87-A30-495-080	TR,2SA1981Y	a
FRONT	S	Q 0602	87-A30-495-080	TR,2SA1981Y	a
FRONT	S	Q 0603	87-A30-200-080	TR,2SA1585SR	a
FRONT	S	Q 0801	87-A30-076-080	C-TR,2SC3052F	a
FRONT	S	Q 0802	87-A30-075-080	C-TR,2SA1235F	a
FRONT	S	Q 0803	87-A30-076-080	C-TR,2SC3052F	a
FRONT	S	Q 0804	87-A30-076-080	C-TR,2SC3052F	a
					CX-SNR41
					EZSC
FRONT	S	Q 0805	87-A30-076-080	C-TR,2SC3052F	a
FRONT	S	Q 0901	87-A30-538-040	C-TR,SRA2202S	a
FRONT	O	R 0109	88-108-224-080	C-RES,U 220K-1/16W J	a
FRONT	O	R 0110	88-108-153-080	C-RES,U 15K-1/16W J	a
FRONT	X	R 0111	88-108-333-080	C-RES,U 33K-1/16W J	a
FRONT	O	R 0112	88-108-224-080	C-RES,U 220K-1/16W J	a
FRONT	O	R 0114	88-108-103-080	C-RES,U 10K-1/16W J	a
FRONT	X	R 0115	88-108-000-080	C-JUMPER,U	a
FRONT	X	R 0116	88-108-124-080	C-RES,U 120K-1/16W J	a
FRONT	X	R 0151	88-100-000-010	PLATING-JW, 0.58 SN95	a
FRONT	X	R 0152	88-100-000-010	PLATING-JW, 0.58 SN95	a
FRONT	X	R 0153	88-128-821-080	C-RES, 820-1/8W J	a
FRONT	X	R 0154	88-128-821-080	C-RES, 820-1/8W J	a
FRONT	O	R 0155	88-108-332-080	C-RES,U 3.3K-1/16W J	a
FRONT	O	R 0156	88-108-332-080	C-RES,U 3.3K-1/16W J	a
FRONT	X	R 0160	88-108-000-080	C-JUMPER,U	a
FRONT	X	R 0161	88-108-000-080	C-JUMPER,U	a
FRONT	X	R 0162	88-108-000-080	C-JUMPER,U	a
FRONT	X	R 0163	88-108-000-080	C-JUMPER,U	a
FRONT	X	R 0164	88-108-000-080	C-JUMPER,U	a
					CX-SNR41
					EZSC
FRONT	X	R 0165	88-108-000-080	C-JUMPER,U	a
FRONT	X	R 0166	88-108-000-080	C-JUMPER,U	a
FRONT	X	R 0201	88-128-681-080	C-RES, 680-1/8W J	a
FRONT	X	R 0202	88-128-681-080	C-RES, 680-1/8W J	a
FRONT	X	R 0203	88-128-681-080	C-RES, 680-1/8W J	a
FRONT	X	R 0208	88-128-102-080	C-RES, 1K-1/8W J	a
FRONT	X	R 0301	88-108-104-080	C-RES,U 100K-1/16W J	a
FRONT	X	R 0302	88-108-472-080	C-RES,U 4.7K-1/16W J	a
FRONT	O	R 0303	88-108-153-080	C-RES,U 15K-1/16W J	a
FRONT	O	R 0304	88-108-102-080	C-RES,U 1K-1/16W J	a
FRONT	X	R 0306	88-108-471-080	C-RES,U 470-1/16W J	a
FRONT	O	R 0321	88-108-103-080	C-RES,U 10K-1/16W J	a
FRONT	O	R 0322	88-108-102-080	C-RES,U 1K-1/16W J	a
FRONT	X	R 0323	88-108-821-080	C-RES,U 820-1/16W J	a
FRONT	X	R 0324	88-108-122-080	C-RES,U 1.2K-1/16W J	a
FRONT	X	R 0325	88-108-122-080	C-RES,U 1.2K-1/16W J	a
FRONT	X	R 0326	88-121-122-080	RES,1.2K-1/8W J	a
FRONT	X	R 0327	88-108-182-080	C-RES,U 1.8K-1/16W J	a
FRONT	X	R 0328	88-121-182-080	RES,1.8K-1/8W J	a
FRONT	O	R 0329	88-108-272-080	C-RES,U 2.7K-1/16W J	a
					CX-SNR41
					EZSC
FRONT	O	R 0330	88-108-332-080	C-RES,U 3.3K-1/16W J	a
FRONT	X	R 0331	88-121-472-080	RES,4.7K-1/8W J	a
FRONT	X	R 0332	88-108-682-080	C-RES,U 6.8K-1/16W J	a
FRONT	O	R 0333	88-108-103-080	C-RES,U 10K-1/16W J	a
FRONT	X	R 0334	88-108-183-080	C-RES,U 18K-1/16W J	a
FRONT	O	R 0335	88-108-473-080	C-RES,U 47K-1/16W J	a
FRONT	O	R 0341	88-108-103-080	C-RES,U 10K-1/16W J	a
FRONT	O	R 0342	88-108-102-080	C-RES,U 1K-1/16W J	a
FRONT	X	R 0343	88-108-821-080	C-RES,U 820-1/16W J	a
FRONT	O	R 0344	88-108-102-080	C-RES,U 1K-1/16W J	a
FRONT	X	R 0345	88-108-122-080	C-RES,U 1.2K-1/16W J	a
FRONT	X	R 0346	88-108-122-080	C-RES,U 1.2K-1/16W J	a
FRONT	X	R 0347	88-108-182-080	C-RES,U 1.8K-1/16W J	a
FRONT	X	R 0348	88-108-182-080	C-RES,U 1.8K-1/16W J	a
FRONT	O	R 0349	88-108-272-080	C-RES,U 2.7K-1/16W J	a
FRONT	O	R 0350	88-108-332-080	C-RES,U 3.3K-1/16W J	a
FRONT	X	R 0351	88-108-472-080	C-RES,U 4.7K-1/16W J	a
FRONT	O	R 0361	88-108-103-080	C-RES,U 10K-1/16W J	a
FRONT	O	R 0362	88-108-103-080	C-RES,U 10K-1/16W J	a
FRONT	X	R 0363	88-108-100-080	C-RES,U 10-1/16W J	a

ELECTRICAL PARTS LIST - 3/15

! = Δ SAFETY PARTS
 C = Components marked

All components used on this model at the production line are shown in this service manual.

However, please note that not all components will be available as spare parts for after-sales service.

Components marked S and O are designated as spare parts for service and will be stocked at the spare parts centers.

Components marked X and R are not designated as spare parts for after sales service, and will not be stocked at the spare parts centers.

UNIT-NAME	! C	REF-NO	PARTS-NO	PARTS-NAME	SUFFIX&MODEL
					CX-SNR41 EZSC
FRONT	X R	0364	88-108-100-080	C-RES,U 10-1/16W J	a
FRONT	O R	0371	88-108-103-080	C-RES,U 10K-1/16W J	a
FRONT	O R	0372	88-108-103-080	C-RES,U 10K-1/16W J	a
FRONT	X R	0373	88-108-100-080	C-RES,U 10-1/16W J	a
FRONT	X R	0374	88-108-100-080	C-RES,U 10-1/16W J	a
FRONT	O R	0601	88-108-103-080	C-RES,U 10K-1/16W J	a
FRONT	X R	0602	88-108-222-080	C-RES,U 2.2K-1/16W J	a
FRONT	O R	0603	88-108-103-080	C-RES,U 10K-1/16W J	a
FRONT	X R	0604	88-108-222-080	C-RES,U 2.2K-1/16W J	a
FRONT	O R	0605	88-108-103-080	C-RES,U 10K-1/16W J	a
FRONT	O R	0606	88-108-102-080	C-RES,U 1K-1/16W J	a
FRONT	X R	0607	88-108-000-080	C-JUMPER,U	a
FRONT	O R	0612	88-108-473-080	C-RES,U 47K-1/16W J	a
FRONT	O R	0613	88-108-473-080	C-RES,U 47K-1/16W J	a
FRONT	O R	0614	88-108-473-080	C-RES,U 47K-1/16W J	a
FRONT	O R	0615	88-108-473-080	C-RES,U 47K-1/16W J	a
FRONT	O R	0616	88-108-473-080	C-RES,U 47K-1/16W J	a
FRONT	X R	0655	88-108-152-080	C-RES,U 1.5K-1/16W J	a
FRONT	X R	0656	88-108-152-080	C-RES,U 1.5K-1/16W J	a
FRONT	X R	0657	88-108-152-080	C-RES,U 1.5K-1/16W J	a
					CX-SNR41 EZSC
FRONT	X R	0658	88-108-152-080	C-RES,U 1.5K-1/16W J	a
FRONT	X R	0659	88-108-152-080	C-RES,U 1.5K-1/16W J	a
FRONT	O R	0701	88-108-102-080	C-RES,U 1K-1/16W J	a
FRONT	X R	0702	88-128-102-080	C-RES, 1K-1/8W J	a
FRONT	O R	0703	88-108-102-080	C-RES,U 1K-1/16W J	a
FRONT	O R	0704	88-108-102-080	C-RES,U 1K-1/16W J	a
FRONT	O R	0705	88-108-102-080	C-RES,U 1K-1/16W J	a
FRONT	O R	0706	88-108-102-080	C-RES,U 1K-1/16W J	a
FRONT	O R	0707	88-108-102-080	C-RES,U 1K-1/16W J	a
FRONT	X R	0708	88-121-102-080	RES,1K-1/8W J	a
FRONT	O R	0709	88-108-101-080	C-RES,U 100-1/16W J	a
FRONT	X R	0710	88-128-101-080	C-RES, 100-1/8W J	a
FRONT	O R	0711	88-108-101-080	C-RES,U 100-1/16W J	a
FRONT	O R	0712	88-108-101-080	C-RES,U 100-1/16W J	a
FRONT	X R	0719	88-108-100-080	C-RES,U 10-1/16W J	a
FRONT	O R	0721	88-108-103-080	C-RES,U 10K-1/16W J	a
FRONT	O R	0730	88-108-102-080	C-RES,U 1K-1/16W J	a
FRONT	O R	0732	88-108-101-080	C-RES,U 100-1/16W J	a
FRONT	O R	0733	88-108-101-080	C-RES,U 100-1/16W J	a
FRONT	O R	0734	88-108-102-080	C-RES,U 1K-1/16W J	a
					CX-SNR41 EZSC
FRONT	O R	0735	88-108-102-080	C-RES,U 1K-1/16W J	a
FRONT	O R	0740	88-108-102-080	C-RES,U 1K-1/16W J	a
FRONT	O R	0741	88-108-101-080	C-RES,U 100-1/16W J	a
FRONT	O R	0742	88-108-102-080	C-RES,U 1K-1/16W J	a
FRONT	X R	0743	88-108-474-080	C-RES,U 470K-1/16W J	a
FRONT	O R	0744	88-108-823-080	C-RES,U 82K-1/16W J	a
FRONT	X R	0745	88-108-104-080	C-RES,U 100K-1/16W J	a
FRONT	X R	0749	88-108-474-080	C-RES,U 470K-1/16W J	a
FRONT	O R	0803	88-108-102-080	C-RES,U 1K-1/16W J	a
FRONT	O R	0804	88-108-224-080	C-RES,U 220K-1/16W J	a
FRONT	X R	0805	88-108-273-080	C-RES,U 27K-1/16W J	a
FRONT	O R	0806	88-108-562-080	C-RES,U 5.6K-1/16W J	a
FRONT	X R	0807	88-108-000-080	C-JUMPER,U	a
FRONT	X R	0808	88-121-101-080	RES,100-1/8W J	a
FRONT	O R	0809	88-108-102-080	C-RES,U 1K-1/16W J	a
FRONT	X R	0810	88-108-182-080	C-RES,U 1.8K-1/16W J	a
FRONT	O R	0811	88-108-224-080	C-RES,U 220K-1/16W J	a
FRONT	O R	0813	88-108-224-080	C-RES,U 220K-1/16W J	a
FRONT	O R	0815	88-108-272-080	C-RES,U 2.7K-1/16W J	a
FRONT	X R	0816	88-108-104-080	C-RES,U 100K-1/16W J	a
					CX-SNR41 EZSC
FRONT	O R	0818	88-108-224-080	C-RES,U 220K-1/16W J	a
FRONT	X R	0819	88-108-222-080	C-RES,U 2.2K-1/16W J	a
FRONT	O R	0820	88-108-101-080	C-RES,U 100-1/16W J	a
FRONT	X R	0821	88-108-104-080	C-RES,U 100K-1/16W J	a
FRONT	O R	0822	88-108-224-080	C-RES,U 220K-1/16W J	a
FRONT	X R	0823	88-100-000-010	PLATING-JW, 0.58 SN95	a
FRONT	X R	0824	88-100-000-010	PLATING-JW, 0.58 SN95	a
FRONT	X R	0825	88-100-000-010	PLATING-JW, 0.58 SN95	a
FRONT	X R	0826	88-108-000-080	C-JUMPER,U	a
FRONT	O R	0827	88-108-473-080	C-RES,U 47K-1/16W J	a
FRONT	X R	0901	88-108-104-080	C-RES,U 100K-1/16W J	a
FRONT	X R	0902	88-108-104-080	C-RES,U 100K-1/16W J	a
FRONT	X R	0903	88-108-104-080	C-RES,U 100K-1/16W J	a
FRONT	X R	0904	88-108-104-080	C-RES,U 100K-1/16W J	a
FRONT	X R	0905	88-108-104-080	C-RES,U 100K-1/16W J	a
FRONT	X R	0906	88-108-104-080	C-RES,U 100K-1/16W J	a
FRONT	X R	0907	88-108-104-080	C-RES,U 100K-1/16W J	a
FRONT	X R	0908	88-108-104-080	C-RES,U 100K-1/16W J	a
FRONT	X R	0909	88-108-104-080	C-RES,U 100K-1/16W J	a
FRONT	X R	0910	88-108-104-080	C-RES,U 100K-1/16W J	a

ELECTRICAL PARTS LIST - 4/15

! = Δ SAFETY PARTS
 C = Components marked

All components used on this model at the production line are shown in this service manual.

However, please note that not all components will be available as spare parts for after-sales service.

Components marked S and O are designated as spare parts for service and will be stocked at the spare parts centers.

Components marked X and R are not designated as spare parts for after sales service, and will not be stocked at the spare parts centers.

UNIT-NAME	! C	REF-NO	PARTS-NO	PARTS-NAME	SUFFIX&MODEL
					CX-SNR41 EZSC
FRONT	X R	0911	88-108-104-080	C-RES,U 100K-1/16W J	a
FRONT	X R	0912	88-108-104-080	C-RES,U 100K-1/16W J	a
FRONT	X R	0913	88-108-104-080	C-RES,U 100K-1/16W J	a
FRONT	X R	0914	88-108-104-080	C-RES,U 100K-1/16W J	a
FRONT	X R	0915	88-108-104-080	C-RES,U 100K-1/16W J	a
FRONT	X R	0916	88-108-104-080	C-RES,U 100K-1/16W J	a
FRONT	X R	0917	88-108-104-080	C-RES,U 100K-1/16W J	a
FRONT	X R	0918	88-108-104-080	C-RES,U 100K-1/16W J	a
FRONT	X R	0919	88-108-104-080	C-RES,U 100K-1/16W J	a
FRONT	X R	0920	88-108-104-080	C-RES,U 100K-1/16W J	a
FRONT	X R	0921	88-108-104-080	C-RES,U 100K-1/16W J	a
FRONT	X R	0922	88-108-104-080	C-RES,U 100K-1/16W J	a
FRONT	X R	0923	88-108-104-080	C-RES,U 100K-1/16W J	a
FRONT	X R	0924	88-108-104-080	C-RES,U 100K-1/16W J	a
FRONT	X R	0925	88-108-104-080	C-RES,U 100K-1/16W J	a
FRONT	X R	0926	88-108-104-080	C-RES,U 100K-1/16W J	a
FRONT	X R	0927	88-108-104-080	C-RES,U 100K-1/16W J	a
FRONT	X R	0928	88-108-104-080	C-RES,U 100K-1/16W J	a
FRONT	X R	0929	88-108-104-080	C-RES,U 100K-1/16W J	a
FRONT	X R	0930	88-108-104-080	C-RES,U 100K-1/16W J	a
					CX-SNR41 EZSC
FRONT	X R	0931	88-108-104-080	C-RES,U 100K-1/16W J	a
FRONT	X R	0932	88-108-104-080	C-RES,U 100K-1/16W J	a
FRONT	X R	0934	88-108-683-080	C-RES,U 68K-1/16W J	a
FRONT	X R	0935	88-108-683-080	C-RES,U 68K-1/16W J	a
FRONT	X R	0936	88-108-104-080	C-RES,U 100K-1/16W J	a
FRONT	X R	0937	88-128-472-080	C-RES, 4.7K-1/8W J	a
FRONT	X R	0938	88-108-472-080	C-RES,U 4.7K-1/16W J	a
FRONT	X R	0939	88-108-472-080	C-RES,U 4.7K-1/16W J	a
FRONT	X R	0940	88-108-104-080	C-RES,U 100K-1/16W J	a
FRONT	X R	0941	88-108-104-080	C-RES,U 100K-1/16W J	a
FRONT	O R	0942	88-108-103-080	C-RES,U 10K-1/16W J	a
FRONT	X R	0943	88-121-472-080	RES,4.7K-1/8W J	a
FRONT	X R	0946	88-108-000-080	C-JUMPER,U	a
FRONT	O R	0951	88-108-102-080	C-RES,U 1K-1/16W J	a
FRONT	X R	0955	88-108-104-080	C-RES,U 100K-1/16W J	a
FRONT	X R	0956	88-108-104-080	C-RES,U 100K-1/16W J	a
FRONT	X R	0957	88-108-104-080	C-RES,U 100K-1/16W J	a
FRONT	X R	0958	88-108-104-080	C-RES,U 100K-1/16W J	a
FRONT	X R	0961	88-121-181-080	RES,180-1/8W J	a
FRONT	O R	0962	88-108-563-080	C-RES,U 56K-1/16W J	a
					CX-SNR41 EZSC
FRONT	O R	0969	88-108-103-080	C-RES,U 10K-1/16W J	a
FRONT	X R	0970	88-108-104-080	C-RES,U 100K-1/16W J	a
FRONT	X R	0971	88-108-104-080	C-RES,U 100K-1/16W J	a
FRONT	X R	0972	88-108-104-080	C-RES,U 100K-1/16W J	a
FRONT	X R	0973	88-108-104-080	C-RES,U 100K-1/16W J	a
FRONT	X R	0974	88-108-104-080	C-RES,U 100K-1/16W J	a
FRONT	O R	0981	88-108-103-080	C-RES,U 10K-1/16W J	a
FRONT	O R	0982	88-108-103-080	C-RES,U 10K-1/16W J	a
FRONT	O R	0983	88-108-103-080	C-RES,U 10K-1/16W J	a
FRONT	O R	0984	88-108-103-080	C-RES,U 10K-1/16W J	a
FRONT	X R	0985	88-121-103-080	RES,10K-1/8W J	a
FRONT	X R	0986	88-121-103-080	RES,10K-1/8W J	a
FRONT	O S	0321	87-A91-024-180	SW,TACT KSHG611BT	a
FRONT	O S	0322	87-A91-024-180	SW,TACT KSHG611BT	a
FRONT	O S	0323	87-A91-024-180	SW,TACT KSHG611BT	a
FRONT	O S	0324	87-A91-024-180	SW,TACT KSHG611BT	a
FRONT	O S	0325	87-A91-024-180	SW,TACT KSHG611BT	a
FRONT	O S	0326	87-A91-024-180	SW,TACT KSHG611BT	a
FRONT	O S	0327	87-A91-024-180	SW,TACT KSHG611BT	a
FRONT	O S	0328	87-A91-024-180	SW,TACT KSHG611BT	a
					CX-SNR41 EZSC
FRONT	O S	0329	87-A91-024-180	SW,TACT KSHG611BT	a
FRONT	O S	0330	87-A91-024-180	SW,TACT KSHG611BT	a
FRONT	O S	0331	87-A91-024-180	SW,TACT KSHG611BT	a
FRONT	O S	0332	87-A91-024-180	SW,TACT KSHG611BT	a
FRONT	O S	0333	87-A91-024-180	SW,TACT KSHG611BT	a
FRONT	O S	0334	87-A91-024-180	SW,TACT KSHG611BT	a
FRONT	O S	0335	87-A91-024-180	SW,TACT KSHG611BT	a
FRONT	O S	0341	87-A91-024-180	SW,TACT KSHG611BT	a
FRONT	O S	0342	87-A91-024-180	SW,TACT KSHG611BT	a
FRONT	O S	0343	87-A91-024-180	SW,TACT KSHG611BT	a
FRONT	O S	0344	87-A91-024-180	SW,TACT KSHG611BT	a
FRONT	O S	0345	87-A91-024-180	SW,TACT KSHG611BT	a
FRONT	O S	0346	87-A91-024-180	SW,TACT KSHG611BT	a
FRONT	O S	0347	87-A91-024-180	SW,TACT KSHG611BT	a
FRONT	O S	0348	87-A91-024-180	SW,TACT KSHG611BT	a
FRONT	O S	0350	87-A91-024-180	SW,TACT KSHG611BT	a
FRONT	O S	0351	87-A91-024-180	SW,TACT KSHG611BT	a
FRONT	O S	0361	87-A92-359-010	SW,RTRY EC12E24604-30MM	a
FRONT	O S	0371	87-A92-273-010	SW,RTRY EC12E12204 30MM	a
HP	O C	0223	87-010-176-080	C-CAP,S 680P-50 J SL C2012	a

ELECTRICAL PARTS LIST - 5/15

! = Δ SAFETY PARTS
 C = Components marked

All components used on this model at the production line are shown in this service manual.

However, please note that not all components will be available as spare parts for after-sales service.

Components marked S and O are designated as spare parts for service and will be stocked at the spare parts centers.

Components marked X and R are not designated as spare parts for after sales service, and will not be stocked at the spare parts centers.

UNIT-NAME	! C	REF-NO	PARTS-NO	PARTS-NAME	SUFFIX&MODEL
					CX-SNR41 EZSC
HP	O C	0224	87-010-176-080	C-CAP,S 680P-50 J SL C2012	a
HP	O J	0201	8C-NF8-680-010	JACK,CKX-3.5-25 ST W/O SW	a
HP	O R	0243	87-A00-440-050	RES,220-1/2W J RP	a
HP	O R	0244	87-A00-440-050	RES,220-1/2W J RP	a
HP	O R	0245	87-A00-440-050	RES,220-1/2W J RP	a
HP	O R	0246	87-A00-440-050	RES,220-1/2W J RP	a
HP	X R	0265	88-128-222-080	C-RES, 2.2K-1/8W J	a
HP	X R	0266	88-128-222-080	C-RES, 2.2K-1/8W J	a
HP	O WH	0201	87-A90-459-010	HLDR,WIRE 2.5-5P	a
MAIN	O C	0003	87-012-368-080	C-CAP,S 0.1-50 Z F GRM	a
MAIN	O C	0004	87-012-368-080	C-CAP,S 0.1-50 Z F GRM	a
MAIN	O C	0005	87-012-368-080	C-CAP,S 0.1-50 Z F GRM	a
MAIN	O C	0006	87-012-368-080	C-CAP,S 0.1-50 Z F GRM	a
MAIN	O C	0009	87-010-759-080	C-CAP,U 0.1-25 Z F CM/CB	a
MAIN	O C	0010	87-010-759-080	C-CAP,U 0.1-25 Z F CM/CB	a
MAIN	O C	0011	87-010-759-080	C-CAP,U 0.1-25 Z F CM/CB	a
MAIN	O C	0012	87-010-759-080	C-CAP,U 0.1-25 Z F CM/CB	a
MAIN	O C	0013	87-012-282-080	C-CAP,U 4700P-50 K B GRM	a
MAIN	O C	0014	87-010-260-080	CAP,E 47-25 M 11L SME	a
MAIN	O C	0016	87-012-286-080	C-CAP,U 0.01-25 K B GRM	a
					CX-SNR41 EZSC
MAIN	O C	0019	87-A12-832-000	CAP,E 3300-56 M 85 GS	a
MAIN	O C	0020	87-A12-832-000	CAP,E 3300-56 M 85 GS	a
MAIN	O C	0021	87-A12-755-000	CAP,E 4700-25 M 85 IV LELON	a
MAIN	O C	0022	87-A12-755-000	CAP,E 4700-25 M 85 IV LELON	a
MAIN	O C	0025	87-010-393-080	CAP,E 100-35 M SME	a
MAIN	O C	0026	87-010-393-080	CAP,E 100-35 M SME	a
MAIN	O C	0030	87-010-247-080	CAP,E 100-50 M SME	a
MAIN	O C	0031	87-010-263-080	CAP,E 100-10 M 11L SME	a
MAIN	O C	0034	87-010-260-080	CAP,E 47-25 M 11L SME	a
MAIN	O C	0035	87-A12-091-080	CAP,E 10-50 SMG	a
MAIN	O C	0036	87-010-260-080	CAP,E 47-25 M 11L SME	a
MAIN	O C	0060	87-010-403-080	CAP,E 3.3-50 M 11L SME	a
MAIN	O C	0061	87-010-260-080	CAP,E 47-25 M 11L SME	a
MAIN	O C	0083	87-010-235-080	CAP,E 470-16 M SME	a
MAIN	O C	0097	87-010-831-080	C-CAP,U 0.1-16 Z F GRM	a
MAIN	O C	0101	87-012-278-080	C-CAP,U 2200P-50 K B GRM	a
MAIN	O C	0102	87-012-278-080	C-CAP,U 2200P-50 K B GRM	a
MAIN	O C	0103	87-010-546-080	CAP,E 0.33-50 M 11L SME	a
MAIN	O C	0104	87-010-546-080	CAP,E 0.33-50 M 11L SME	a
MAIN	O C	0107	87-010-405-080	CAP,E 10-50 M 11L SME	a
					CX-SNR41 EZSC
MAIN	O C	0108	87-010-405-080	CAP,E 10-50 M 11L SME	a
MAIN	O C	0109	87-012-195-080	C-CAP,U 100P-50 J CH GRM	a
MAIN	O C	0110	87-012-195-080	C-CAP,U 100P-50 J CH GRM	a
MAIN	O C	0111	87-010-407-080	CAP,E 33-50 M 11L SME	a
MAIN	O C	0112	87-010-407-080	CAP,E 33-50 M 11L SME	a
MAIN	O C	0113	87-A10-596-080	C-CAP,S 100P-100 J CH	a
MAIN	O C	0114	87-A10-596-080	C-CAP,S 100P-100 J CH	a
MAIN	O C	0117	87-012-368-080	C-CAP,S 0.1-50 Z F GRM	a
MAIN	O C	0118	87-012-368-080	C-CAP,S 0.1-50 Z F GRM	a
MAIN	O C	0119	87-012-286-080	C-CAP,U 0.01-25 K B GRM	a
MAIN	O C	0120	87-012-286-080	C-CAP,U 0.01-25 K B GRM	a
MAIN	O C	0121	87-010-401-080	CAP,E 1-50 M 11L SME	a
MAIN	O C	0122	87-010-401-080	CAP,E 1-50 M 11L SME	a
MAIN	O C	0123	87-010-177-080	C-CAP,S 820P-50 J SL C2012	a
MAIN	O C	0124	87-010-177-080	C-CAP,S 820P-50 J SL C2012	a
MAIN	O C	0125	87-A10-596-080	C-CAP,S 100P-100 J CH	a
MAIN	O C	0126	87-A10-596-080	C-CAP,S 100P-100 J CH	a
MAIN	O C	0133	87-012-282-080	C-CAP,U 4700P-50 K B GRM	a
MAIN	O C	0140	87-012-278-080	C-CAP,U 2200P-50 K B GRM	a
MAIN	O C	0145	87-010-971-080	C-CAP,S 4700P-50 J B GRM	a
					CX-SNR41 EZSC
MAIN	O C	0146	87-010-971-080	C-CAP,S 4700P-50 J B GRM	a
MAIN	O C	0186	87-010-759-080	C-CAP,U 0.1-25 Z F CM/CB	a
MAIN	O C	0187	87-A12-890-080	CAP,E 10-63 VR	a
MAIN	O C	0188	87-A12-890-080	CAP,E 10-63 VR	a
MAIN	O C	0201	87-A10-260-080	C-CAP,U 0.1-16 K B	a
MAIN	O C	0225	87-012-368-080	C-CAP,S 0.1-50 Z F GRM	a
MAIN	O C	0226	87-012-368-080	C-CAP,S 0.1-50 Z F GRM	a
MAIN	O C	0227	87-012-368-080	C-CAP,S 0.1-50 Z F GRM	a
MAIN	O C	0228	87-012-368-080	C-CAP,S 0.1-50 Z F GRM	a
MAIN	O C	0229	87-010-191-080	C-CAP,S 0.015-50 Z F GRM	a
MAIN	O C	0230	87-010-191-080	C-CAP,S 0.015-50 Z F GRM	a
MAIN	O C	0231	87-012-286-080	C-CAP,U 0.01-25 K B GRM	a
MAIN	O C	0232	87-012-286-080	C-CAP,U 0.01-25 K B GRM	a
MAIN	O C	0241	87-010-831-080	C-CAP,U 0.1-16 Z F GRM	a
MAIN	O C	0301	87-012-275-080	C-CAP,U 1200P-50 K B GRM	a
MAIN	O C	0302	87-012-275-080	C-CAP,U 1200P-50 K B GRM	a
MAIN	O C	0303	87-012-275-080	C-CAP,U 1200P-50 K B GRM	a
MAIN	O C	0304	87-012-275-080	C-CAP,U 1200P-50 K B GRM	a
MAIN	O C	0310	87-012-274-080	C-CAP,U 1000P-50 K B GRM	a
MAIN	O C	0363	87-010-759-080	C-CAP,U 0.1-25 Z F CM/CB	a

ELECTRICAL PARTS LIST - 6/15

! = SAFETY PARTS
 C = Components marked

All components used on this model at the production line are shown in this service manual.
 However, please note that not all components will be available as spare parts for after-sales service.
 Components marked S and O are designated as spare parts for service and will be stocked at the spare parts centers.
 Components marked X and R are not designated as spare parts for after sales service, and will not be stocked at the spare parts centers.

UNIT-NAME	! C	REF-NO	PARTS-NO	PARTS-NAME	SUFFIX&MODEL
					CX-SNR41 EZSC
MAIN	O C	0451	87-010-759-080	C-CAP,U 0.1-25 Z F CM/CB	a
MAIN	O C	0452	87-010-406-080	CAP,E 22-50 M 11L SME	a
MAIN	O C	0453	87-012-279-080	C-CAP,U 2700P-50 K B GRM	a
MAIN	O C	0454	87-012-279-080	C-CAP,U 2700P-50 K B GRM	a
MAIN	O C	0455	87-012-279-080	C-CAP,U 2700P-50 K B GRM	a
MAIN	O C	0456	87-012-286-080	C-CAP,U 0.01-25 K B GRM	a
MAIN	O C	0457	87-A12-361-080	CAP,M 5600P-100 J CP	a
MAIN	O C	0458	87-012-278-080	C-CAP,U 2200P-50 K B GRM	a
MAIN	O C	0459	87-012-271-080	C-CAP,U 560P-50 K B GRM	a
MAIN	O C	0460	87-A12-317-080	C-CAP,U 0.1-50 Z F	a
MAIN	O C	0461	87-012-158-080	C-CAP,S 390P-50 J CH GRM	a
MAIN	O C	0462	87-012-158-080	C-CAP,S 390P-50 J CH GRM	a
MAIN	O C	0463	87-010-759-080	C-CAP,U 0.1-25 Z F CM/CB	a
MAIN	O C	0464	87-012-278-080	C-CAP,U 2200P-50 K B GRM	a
MAIN	O C	0465	87-012-286-080	C-CAP,U 0.01-25 K B GRM	a
MAIN	O C	0601	87-012-188-080	C-CAP,U 47P-50 J CH GRM	a
MAIN	O C	0602	87-012-188-080	C-CAP,U 47P-50 J CH GRM	a
MAIN	O C	0603	87-010-263-080	CAP,E 100-10 M 11L SME	a
MAIN	O C	0604	87-010-263-080	CAP,E 100-10 M 11L SME	a
MAIN	O C	0605	87-A12-362-080	CAP,M 6800P-100 J CP	a
					CX-SNR41 EZSC
MAIN	O C	0606	87-A12-362-080	CAP,M 6800P-100 J CP	a
MAIN	O C	0607	87-012-270-080	C-CAP,U 470P-50 K B GRM	a
MAIN	O C	0608	87-012-270-080	C-CAP,U 470P-50 K B GRM	a
MAIN	O C	0609	87-010-401-080	CAP,E 1-50 M 11L SME	a
MAIN	O C	0610	87-010-401-080	CAP,E 1-50 M 11L SME	a
MAIN	O C	0611	87-A12-790-080	C-CAP,U 560P-50 J CH	a
MAIN	O C	0612	87-A12-790-080	C-CAP,U 560P-50 J CH	a
MAIN	O C	0613	87-012-280-080	C-CAP,U 3300P-50 K B GRM	a
MAIN	O C	0614	87-012-280-080	C-CAP,U 3300P-50 K B GRM	a
MAIN	O C	0615	87-010-545-080	CAP,E 0.22-50 M 11L SME	a
MAIN	O C	0616	87-010-545-080	CAP,E 0.22-50 M 11L SME	a
MAIN	O C	0617	87-010-545-080	CAP,E 0.22-50 M 11L SME	a
MAIN	O C	0618	87-010-545-080	CAP,E 0.22-50 M 11L SME	a
MAIN	O C	0625	87-012-198-080	C-CAP,U 180P-50 J CH GRM	a
MAIN	O C	0626	87-012-198-080	C-CAP,U 180P-50 J CH GRM	a
MAIN	O C	0627	87-012-284-080	C-CAP,U 6800P-50 K B GRM	a
MAIN	O C	0628	87-012-284-080	C-CAP,U 6800P-50 K B GRM	a
MAIN	O C	0629	87-012-286-080	C-CAP,U 0.01-25 K B GRM	a
MAIN	O C	0630	87-012-286-080	C-CAP,U 0.01-25 K B GRM	a
MAIN	O C	0631	87-012-278-080	C-CAP,U 2200P-50 K B GRM	a
					CX-SNR41 EZSC
MAIN	O C	0632	87-012-278-080	C-CAP,U 2200P-50 K B GRM	a
MAIN	O C	0641	87-010-401-080	CAP,E 1-50 M 11L SME	a
MAIN	O C	0642	87-010-401-080	CAP,E 1-50 M 11L SME	a
MAIN	O C	0651	87-A12-063-080	CAP,E 220-10 SMG	a
MAIN	O C	0652	87-010-260-080	CAP,E 47-25 M 11L SME	a
MAIN	O C	0655	87-010-404-080	CAP,E 4.7-50 M 11L SME	a
MAIN	O C	0656	87-010-784-080	C-CAP,U 0.012-25 K B GRM	a
MAIN	O C	0663	87-010-759-080	C-CAP,U 0.1-25 Z F CM/CB	a
MAIN	O C	0664	87-010-759-080	C-CAP,U 0.1-25 Z F CM/CB	a
MAIN	O C	0665	87-A10-504-080	C-CAP,U 0.047-16 K B	a
MAIN	O C	0666	87-A10-504-080	C-CAP,U 0.047-16 K B	a
MAIN	O C	0677	87-012-286-080	C-CAP,U 0.01-25 K B GRM	a
MAIN	O C	0771	87-010-263-080	CAP,E 100-10 M 11L SME	a
MAIN	O C	0772	87-012-286-080	C-CAP,U 0.01-25 K B GRM	a
MAIN	X C	0781	88-108-000-080	C-JUMPER,U	a
MAIN	O C	0782	87-012-286-080	C-CAP,U 0.01-25 K B GRM	a
MAIN	O C	0783	87-012-286-080	C-CAP,U 0.01-25 K B GRM	a
MAIN	O C	0784	87-012-286-080	C-CAP,U 0.01-25 K B GRM	a
MAIN	O C	0785	87-012-286-080	C-CAP,U 0.01-25 K B GRM	a
MAIN	O C	0786	87-012-286-080	C-CAP,U 0.01-25 K B GRM	a
					CX-SNR41 EZSC
MAIN	O C	0788	87-012-167-080	C-CAP,U 5P-50 C CH GRM	a
MAIN	O C	0789	87-016-118-080	C-CAP,U 0.022-25 J B GRM	a
MAIN	O C	0790	87-016-118-080	C-CAP,U 0.022-25 J B GRM	a
MAIN	O C	0791	87-010-759-080	C-CAP,U 0.1-25 Z F CM/CB	a
MAIN	O C	0792	87-012-286-080	C-CAP,U 0.01-25 K B GRM	a
MAIN	O C	0793	87-010-404-080	CAP,E 4.7-50 M 11L SME	a
MAIN	O C	0795	87-012-286-080	C-CAP,U 0.01-25 K B GRM	a
MAIN	O C	0796	87-012-286-080	C-CAP,U 0.01-25 K B GRM	a
MAIN	O C	0797	87-010-405-080	CAP,E 10-50 M 11L SME	a
MAIN	O C	0798	87-012-286-080	C-CAP,U 0.01-25 K B GRM	a
MAIN	O C	0799	87-010-265-080	CAP,E 33-16 M 11L SME	a
MAIN	O C	0800	87-010-829-080	C-CAP,U 0.047-16 Z F CM/CB	a
MAIN	O C	0801	87-010-403-080	CAP,E 3.3-50 M 11L SME	a
MAIN	O C	0802	87-010-829-080	C-CAP,U 0.047-16 Z F CM/CB	a
MAIN	O C	0803	87-010-787-080	C-CAP,U 0.022-25 K B GRM	a
MAIN	O C	0804	87-010-263-080	CAP,E 100-10 M 11L SME	a
MAIN	O C	0807	87-010-400-080	CAP,E 0.47-50 M 11L SME	a
MAIN	O C	0808	87-010-401-080	CAP,E 1-50 M 11L SME	a
MAIN	O C	0809	87-010-401-080	CAP,E 1-50 M 11L SME	a
MAIN	O C	0810	87-010-759-080	C-CAP,U 0.1-25 Z F CM/CB	a

ELECTRICAL PARTS LIST - 7/15

! = Δ SAFETY PARTS
 C = Components marked

All components used on this model at the production line are shown in this service manual.
 However, please note that not all components will be available as spare parts for after-sales service.
 Components marked S and O are designated as spare parts for service and will be stocked at the spare parts centers.
 Components marked X and R are not designated as spare parts for after sales service, and will not be stocked at the spare parts centers.

UNIT-NAME	! C	REF-NO	PARTS-NO	PARTS-NAME	SUFFIX&MODEL
					CX-SNR41 EZSC
MAIN	O C	0814	87-012-286-080	C-CAP,U 0.01-25 K B GRM	a
MAIN	O C	0815	87-010-400-080	CAP,E 0.47-50 M 11L SME	a
MAIN	O C	0816	87-010-400-080	CAP,E 0.47-50 M 11L SME	a
MAIN	O C	0818	87-012-276-080	C-CAP,U 1500P-50 K B GRM	a
MAIN	O C	0821	87-010-405-080	CAP,E 10-50 M 11L SME	a
MAIN	X C	0822	88-108-000-080	C-JUMPER,U	a
MAIN	O C	0823	87-012-349-080	C-CAP,S 1000P-50 J CH GRM	a
MAIN	O C	0824	87-010-404-080	CAP,E 4.7-50 M 11L SME	a
MAIN	O C	0825	87-010-596-080	C-CAP,S 0.047-16 K R C2012	a
MAIN	O C	0831	87-010-406-080	CAP,E 22-50 M 11L SME	a
MAIN	O C	0842	87-012-286-080	C-CAP,U 0.01-25 K B GRM	a
MAIN	X C	0843	88-108-000-080	C-JUMPER,U	a
MAIN	O C	0844	87-012-286-080	C-CAP,U 0.01-25 K B GRM	a
MAIN	X C	0845	88-108-000-080	C-JUMPER,U	a
MAIN	X C	0846	88-108-000-080	C-JUMPER,U	a
MAIN	X C	0847	88-108-000-080	C-JUMPER,U	a
MAIN	X C	0848	88-108-000-080	C-JUMPER,U	a
MAIN	X C	0849	88-108-000-080	C-JUMPER,U	a
MAIN	O C	0850	87-010-260-080	CAP,E 47-25 M 11L SME	a
MAIN	O C	0851	87-012-286-080	C-CAP,U 0.01-25 K B GRM	a
					CX-SNR41 EZSC
MAIN	O C	0852	87-012-286-080	C-CAP,U 0.01-25 K B GRM	a
MAIN	O C	0853	87-012-286-080	C-CAP,U 0.01-25 K B GRM	a
MAIN	O C	0859	87-010-759-080	C-CAP,U 0.1-25 Z F CM/CB	a
MAIN	O C	0860	87-012-286-080	C-CAP,U 0.01-25 K B GRM	a
MAIN	O C	0869	87-012-286-080	C-CAP,U 0.01-25 K B GRM	a
MAIN	O C	0870	87-012-274-080	C-CAP,U 1000P-50 K B GRM	a
MAIN	O C	0871	87-012-199-080	C-CAP,U 220P-50 J CH GRM	a
MAIN	O C	0872	87-012-199-080	C-CAP,U 220P-50 J CH GRM	a
MAIN	O C	0873	87-A10-039-080	C-CAP,U 470P-50 J CH	a
MAIN	O C	0874	87-010-405-080	CAP,E 10-50 M 11L SME	a
MAIN	O C	0875	87-010-759-080	C-CAP,U 0.1-25 Z F CM/CB	a
MAIN	O C	0876	87-010-405-080	CAP,E 10-50 M 11L SME	a
MAIN	O C	0877	87-012-286-080	C-CAP,U 0.01-25 K B GRM	a
MAIN	O C	0878	87-012-184-080	C-CAP,U 33P-50 J CH GRM	a
MAIN	O C	0879	87-012-180-080	C-CAP,U 22P-50 J CH GRM	a
MAIN	O C	0901	87-012-162-080	C-CAP,U 1P-50 C CH GRM	a
MAIN	O C	0902	87-012-165-080	C-CAP,U 3P-50 C CH GRM	a
MAIN	O C	0903	87-012-164-080	C-CAP,U 2P-50 C CH GRM	a
MAIN	O C	0904	86-ZA1-615-080	C-CAP,U 680P-25 J CH	a
MAIN	O C	0905	87-012-162-080	C-CAP,U 1P-50 C CH GRM	a
					CX-SNR41 EZSC
MAIN	O C	0906	87-012-172-080	C-CAP,U 10P-50 D CH GRM	a
MAIN	O C	0907	87-012-166-080	C-CAP,U 4P-50 C CH GRM	a
MAIN	O C	0908	87-012-165-080	C-CAP,U 3P-50 C CH GRM	a
MAIN	O C	0909	86-ZA1-615-080	C-CAP,U 680P-25 J CH	a
MAIN	O C	0910	87-012-164-080	C-CAP,U 2P-50 C CH GRM	a
MAIN	O C	0911	87-012-166-080	C-CAP,U 4P-50 C CH GRM	a
MAIN	O C	0912	87-012-195-080	C-CAP,U 100P-50 J CH GRM	a
MAIN	O C	0913	86-ZA1-616-080	C-CAP,U 0.01-50 K B (MUR)	a
MAIN	O C	0914	86-ZA1-616-080	C-CAP,U 0.01-50 K B (MUR)	a
MAIN	O C	0915	86-ZA1-616-080	C-CAP,U 0.01-50 K B (MUR)	a
MAIN	O C	0916	86-ZA1-616-080	C-CAP,U 0.01-50 K B (MUR)	a
MAIN	O C	0917	87-012-178-080	C-CAP,U 18P-50 J CH GRM	a
MAIN	O C	0918	87-012-172-080	C-CAP,U 10P-50 D CH GRM	a
MAIN	O C	0919	87-012-184-080	C-CAP,U 33P-50 J CH GRM	a
MAIN	O C	0920	87-012-184-080	C-CAP,U 33P-50 J CH GRM	a
MAIN	O C	0921	87-012-180-080	C-CAP,U 22P-50 J CH GRM	a
MAIN	O C	0922	87-012-174-080	C-CAP,U 12P-50 J CH GRM	a
MAIN	O C	0923	86-ZA1-616-080	C-CAP,U 0.01-50 K B (MUR)	a
MAIN	O C	0924	87-012-164-080	C-CAP,U 2P-50 C CH GRM	a
MAIN	O C	0925	87-012-164-080	C-CAP,U 2P-50 C CH GRM	a
					CX-SNR41 EZSC
MAIN	O C	0926	86-ZA1-616-080	C-CAP,U 0.01-50 K B (MUR)	a
MAIN	O C	0931	87-A12-319-080	C-CAP,U 0.1-25 K B	a
MAIN	O C	0940	87-012-286-080	C-CAP,U 0.01-25 K B GRM	a
MAIN	O C	0942	87-012-165-080	C-CAP,U 3P-50 C CH GRM	a
MAIN	O C	0947	87-012-286-080	C-CAP,U 0.01-25 K B GRM	a
MAIN	O C	0948	87-A10-039-080	C-CAP,U 470P-50 J CH	a
MAIN	O C	0952	87-012-286-080	C-CAP,U 0.01-25 K B GRM	a
MAIN	O C	0958	87-012-286-080	C-CAP,U 0.01-25 K B GRM	a
MAIN	O C	0959	87-010-759-080	C-CAP,U 0.1-25 Z F CM/CB	a
MAIN	O C	0960	87-010-759-080	C-CAP,U 0.1-25 Z F CM/CB	a
MAIN	O C	0962	87-010-401-080	CAP,E 1-50 M 11L SME	a
MAIN	O C	0963	87-A12-319-080	C-CAP,U 0.1-25 K B	a
MAIN	O C	0971	87-010-381-080	CAP,E 330-16 M SME	a
MAIN	O C	0972	87-010-404-080	CAP,E 4.7-50 M 11L SME	a
MAIN	O C	0973	87-012-286-080	C-CAP,U 0.01-25 K B GRM	a
MAIN	O C	0974	87-012-286-080	C-CAP,U 0.01-25 K B GRM	a
MAIN	O C	0979	87-012-195-080	C-CAP,U 100P-50 J CH GRM	a
MAIN	O C	0981	87-010-260-080	CAP,E 47-25 M 11L SME	a
MAIN	O C	0982	87-010-759-080	C-CAP,U 0.1-25 Z F CM/CB	a
MAIN	O C	0983	87-012-286-080	C-CAP,U 0.01-25 K B GRM	a

ELECTRICAL PARTS LIST - 8/15

! = SAFETY PARTS
 C = Components marked

All components used on this model at the production line are shown in this service manual.

However, please note that not all components will be available as spare parts for after-sales service.

Components marked S and O are designated as spare parts for service and will be stocked at the spare parts centers.

Components marked X and R are not designated as spare parts for after sales service, and will not be stocked at the spare parts centers.

UNIT-NAME	! C	REF-NO	PARTS-NO	PARTS-NAME	SUFFIX&MODEL
					CX-SNR41 EZSC
MAIN	O C	0984	87-012-286-080	C-CAP,U 0.01-25 K B GRM	a
MAIN	O C	0985	87-012-195-080	C-CAP,U 100P-50 J CH GRM	a
MAIN	O C	0987	87-012-286-080	C-CAP,U 0.01-25 K B GRM	a
MAIN	O C	0988	87-012-286-080	C-CAP,U 0.01-25 K B GRM	a
MAIN	O C	0989	87-012-286-080	C-CAP,U 0.01-25 K B GRM	a
MAIN	O C	0991	87-012-176-080	C-CAP,U 15P-50 J CH GRM	a
MAIN	O C	0992	87-012-176-080	C-CAP,U 15P-50 J CH GRM	a
MAIN	O C	0993	87-012-274-080	C-CAP,U 1000P-50 K B GRM	a
MAIN	O C	0995	87-012-274-080	C-CAP,U 1000P-50 K B GRM	a
MAIN	O C	0997	87-010-759-080	C-CAP,U 0.1-25 Z F CM/CB	a
MAIN	O C	0998	87-010-260-080	CAP,E 47-25 M 11L SME	a
MAIN	O C	0999	87-A11-155-080	CAP,TC U 0.01-16 Z F	a
MAIN	O CF	0831	87-008-423-010	FLTR,CF SFE10.7MS3G-A	a
MAIN	O CF	0832	82-785-747-010	CF,MS2GH-A	a
MAIN	X CLP0201	87-A60-884-010	PIN,DIAL COATING-SHS	a	
MAIN	X CLP0303	87-A60-884-010	PIN,DIAL COATING-SHS	a	
MAIN	X CLP0304	87-A60-884-010	PIN,DIAL COATING-SHS	a	
MAIN	O CN 0301	87-A60-620-010	CONN,3P V 2MM JMT	a	
MAIN	O CN 0302	87-A60-625-010	CONN,8P V 2MM JMT	a	
MAIN	O CN 0601	87-099-719-010	CONN,30P H BLK TYK-B(X)	a	
					CX-SNR41 EZSC
MAIN	O CN 0602	87-099-194-010	CONN,6P V BLK 6216	a	
MAIN	S D 0005	87-A40-393-090	DIODE,1N5402GW(F20)	a	
MAIN	S D 0006	87-A40-393-090	DIODE,1N5402GW(F20)	a	
MAIN	S D 0007	87-A40-393-090	DIODE,1N5402GW(F20)	a	
MAIN	S D 0008	87-A40-393-090	DIODE,1N5402GW(F20)	a	
MAIN	S D 0011	87-A40-270-080	C-DIODE,MC2838	a	
MAIN	S D 0013	87-A40-455-090	DIODE,RL203 GW	a	
MAIN	S D 0014	87-A40-455-090	DIODE,RL203 GW	a	
MAIN	S D 0015	87-A40-455-090	DIODE,RL203 GW	a	
MAIN	S D 0016	87-A40-455-090	DIODE,RL203 GW	a	
MAIN	S D 0021	87-A40-345-080	ZENER,MTZJ10C	a	
MAIN	S D 0026	87-A40-553-080	DIODE,1N4003 LES	a	
MAIN	S D 0027	87-A40-553-080	DIODE,1N4003 LES	a	
MAIN	S D 0029	87-A40-336-080	ZENER,MTZJ27D T-72	a	
MAIN	S D 0030	87-020-465-080	DIODE,1SS133	a	
MAIN	S D 0032	87-020-465-080	DIODE,1SS133	a	
MAIN	S D 0041	87-A40-270-080	C-DIODE,MC2838	a	
MAIN	S D 0042	87-A40-269-080	C-DIODE,MC2836	a	
MAIN	S D 0060	87-020-465-080	DIODE,1SS133	a	
MAIN	S D 0063	87-A40-270-080	C-DIODE,MC2838	a	
					CX-SNR41 EZSC
MAIN	S D 0064	87-A40-269-080	C-DIODE,MC2836	a	
MAIN	S D 0076	87-A40-269-080	C-DIODE,MC2836	a	
MAIN	S D 0077	87-A40-270-080	C-DIODE,MC2838	a	
MAIN	S D 0101	87-A40-269-080	C-DIODE,MC2836	a	
MAIN	S D 0103	87-020-465-080	DIODE,1SS133	a	
MAIN	S D 0104	87-020-465-080	DIODE,1SS133	a	
MAIN	S D 0105	87-A40-269-080	C-DIODE,MC2836	a	
MAIN	S D 0106	87-A40-269-080	C-DIODE,MC2836	a	
MAIN	S D 0107	87-A40-270-080	C-DIODE,MC2838	a	
MAIN	S D 0108	87-A40-270-080	C-DIODE,MC2838	a	
MAIN	S D 0109	87-A40-488-080	DIODE,1SS244	a	
MAIN	S D 0110	87-A40-488-080	DIODE,1SS244	a	
MAIN	S D 0150	87-A40-270-080	C-DIODE,MC2838	a	
MAIN	S D 0160	87-A40-270-080	C-DIODE,MC2838	a	
MAIN	S D 0185	87-A40-393-090	DIODE,1N5402GW(F20)	a	
MAIN	S D 0186	87-A40-393-090	DIODE,1N5402GW(F20)	a	
MAIN	S D 0187	87-A40-871-080	ZENER,MTZJ5.6C	a	
MAIN	S D 0188	87-017-931-080	ZENER,MTZJ5.6B	a	
MAIN	S D 0189	87-A40-270-080	C-DIODE,MC2838	a	
MAIN	S D 0190	87-A40-269-080	C-DIODE,MC2836	a	
					CX-SNR41 EZSC
MAIN	S D 0191	87-A40-345-080	ZENER,MTZJ10C	a	
MAIN	S D 0192	87-020-465-080	DIODE,1SS133	a	
MAIN	S D 0193	87-020-465-080	DIODE,1SS133	a	
MAIN	S D 0280	87-A40-269-080	C-DIODE,MC2836	a	
MAIN	S D 0281	87-A40-270-080	C-DIODE,MC2838	a	
MAIN	S D 0301	87-A40-269-080	C-DIODE,MC2836	a	
MAIN	S D 0661	87-A40-438-080	ZENER,MTZJ4.7A	a	
MAIN	S D 0662	87-A40-438-080	ZENER,MTZJ4.7A	a	
MAIN	S D 0801	87-020-465-080	DIODE,1SS133	a	
MAIN	S D 0803	87-020-465-080	DIODE,1SS133	a	
MAIN	O D 0901	87-A41-048-040	C-VARI-CAP,HVM16-03 TL	a	
MAIN	O D 0902	87-A41-048-040	C-VARI-CAP,HVM16-03 TL	a	
MAIN	O D 0903	87-A41-048-040	C-VARI-CAP,HVM16-03 TL	a	
MAIN	S D 0942	87-A40-270-080	C-DIODE,MC2838	a	
MAIN	S D 0944	87-020-465-080	DIODE,1SS133	a	
MAIN	O D 0951	87-A40-799-040	C-VARI-CAP,KV1610S	a	
MAIN	S D 0991	87-017-149-080	ZENER,HZS6A2L	a	
MAIN	S D 0992	87-020-465-080	DIODE,1SS133	a	
MAIN	S D 0994	87-020-465-080	DIODE,1SS133	a	
MAIN	X FB 0601	88-118-000-080	C-JUMPER,S	a	

ELECTRICAL PARTS LIST - 9/15

! = SAFETY PARTS
C = Components marked

All components used on this model at the production line are shown in this service manual.

However, please note that not all components will be available as spare parts for after-sales service.

Components marked S and O are designated as spare parts for service and will be stocked at the spare parts centers.

Components marked X and R are not designated as spare parts for after sales service, and will not be stocked at the spare parts centers.

UNIT-NAME	! C	REF-NO	PARTS-NO	PARTS-NAME	SUFFIX&MODEL
					CX-SNR41
					EZSC
MAIN	X	FB 0602	88-118-000-080	C-JUMPER,S	a
MAIN	X	FB 0603	88-100-000-010	PLATING-JW, 0.58 SN95	a
MAIN	O	FFC0602	88-906-251-110	FF-CABLE,6P 1.25	a
MAIN	S	IC 0001	87-A21-364-010	IC,NJM7806FA(A)	a
MAIN	S	IC 0601	87-A22-236-040	C-IC,BD3881FV	a
MAIN	S	IC 0801	87-A22-060-010	IC,LA1845N-A	a
MAIN	S	IC 0861	87-A20-440-040	C-IC,BU1920FS	a
MAIN	S	IC 0991	87-A21-928-010	IC,LC72131D-N	a
MAIN	O	J 0203	87-A60-238-010	TERMINAL,SP 4P (MSC)	a
MAIN	O	J 0602	8C-NF8-682-010	JACK,PIN 2P RCA-207	a
MAIN	X	J 0832	87-A60-403-010	TERMINAL,ANT PAL 2P HSP-312V X	a
MAIN	X	JR 0808	88-108-474-080	C-RES,U 470K-1/16W J	a
MAIN	O	L 0201	87-A50-611-010	COIL,1UH K(CS)	a
MAIN	O	L 0202	87-A50-611-010	COIL,1UH K(CS)	a
MAIN	O	L 0451	87-007-342-010	COIL,OSC 85KHZ BIAS	a
MAIN	O	L 0801	87-A50-608-010	COIL,FM DET-N(TOK)	a
MAIN	O	L 0802	87-A91-551-010	FLTR,PCFJZH-450 L(TOK)	a
MAIN	O	L 0811	87-005-847-080	COIL,2.2UH K CECS	a
MAIN	O	L 0832	87-005-847-080	COIL,2.2UH K CECS	a
MAIN	O	L 0861	87-005-847-080	COIL,2.2UH K CECS	a
					CX-SNR41
					EZSC
MAIN	O	L 0901	86-ZA1-612-010	COIL,FM ANT/RF-1-Z	a
MAIN	O	L 0902	86-ZA1-613-010	COIL,FM ANT/RF-2-Z	a
MAIN	O	L 0903	87-005-847-080	COIL,2.2UH K CECS	a
MAIN	O	L 0904	86-ZA1-612-010	COIL,FM ANT/RF-1-Z	a
MAIN	O	L 0905	86-ZA1-613-010	COIL,FM ANT/RF-2-Z	a
MAIN	O	L 0906	87-005-847-080	COIL,2.2UH K CECS	a
MAIN	O	L 0907	86-ZA1-614-010	COIL,FM OSC-Z	a
MAIN	O	L 0908	88-ZA1-624-010	COIL,FM IFT 7-6.2 (COILS)	a
MAIN	O	L 0941	87-A50-020-010	COIL,ANT LW (COI) 252KHZ	a
MAIN	O	L 0942	87-A50-019-010	COIL,OSC LW (COI) 856KHZ	a
MAIN	O	L 0952	87-A50-766-010	COIL,MW ANT 3BLW(COI)	a
MAIN	O	L 0953	87-A50-767-010	COIL,MW OSC 3BLW(COI)	a
MAIN	S	Q 0001	87-A30-494-080	TR,2SA1980G	a
MAIN	S	Q 0002	87-A30-494-080	TR,2SA1980G	a
MAIN	S	Q 0003	87-A30-076-080	C-TR,2SC3052F	a
MAIN	S	Q 0006	87-A30-076-080	C-TR,2SC3052F	a
MAIN	S	Q 0009	87-A30-494-080	TR,2SA1980G	a
MAIN	S	Q 0010	87-A30-076-080	C-TR,2SC3052F	a
MAIN	S	Q 0011	87-A30-614-010	TR,2SB1548	a
MAIN	S	Q 0012	87-A30-630-080	TR,2SC5343GL	a
					CX-SNR41
					EZSC
MAIN	S	Q 0060	87-A30-076-080	C-TR,2SC3052F	a
MAIN	S	Q 0061	87-A30-075-080	C-TR,2SA1235F	a
MAIN	S	Q 0062	87-A30-076-080	C-TR,2SC3052F	a
MAIN	S	Q 0063	87-A30-075-080	C-TR,2SA1235F	a
MAIN	S	Q 0064	87-A30-076-080	C-TR,2SC3052F	a
MAIN	S	Q 0101	87-A30-257-080	C-TR,2SD1306E	a
MAIN	S	Q 0102	87-A30-257-080	C-TR,2SD1306E	a
MAIN	S	Q 0103	87-A30-663-040	C-TR,2SB792A(RS)	a
MAIN	S	Q 0104	87-A30-663-040	C-TR,2SB792A(RS)	a
MAIN	S	Q 0105	87-A30-663-040	C-TR,2SB792A(RS)	a
MAIN	S	Q 0106	87-A30-663-040	C-TR,2SB792A(RS)	a
MAIN	S	Q 0107	87-A30-076-080	C-TR,2SC3052F	a
MAIN	S	Q 0108	87-A30-076-080	C-TR,2SC3052F	a
MAIN	S	Q 0109	87-A30-076-080	C-TR,2SC3052F	a
MAIN	S	Q 0110	87-A30-076-080	C-TR,2SC3052F	a
MAIN	S	Q 0111	87-A30-668-080	TR,2SC3478LK	a
MAIN	S	Q 0112	87-A30-668-080	TR,2SC3478LK	a
MAIN	S	Q 0113	87-A30-076-080	C-TR,2SC3052F	a
MAIN	S	Q 0114	87-A30-076-080	C-TR,2SC3052F	a
MAIN	S	Q 0115	87-A30-662-040	C-TR,2SD814A(RS)	a
					CX-SNR41
					EZSC
MAIN	S	Q 0116	87-A30-662-040	C-TR,2SD814A(RS)	a
MAIN	S	Q 0117	87-A30-528-010	TR,2SB1686	a
MAIN	S	Q 0118	87-A30-528-010	TR,2SB1686	a
MAIN	S	Q 0119	87-A30-529-010	TR,2SD2642	a
MAIN	S	Q 0120	87-A30-529-010	TR,2SD2642	a
MAIN	S	Q 0123	87-A30-663-040	C-TR,2SB792A(RS)	a
MAIN	S	Q 0124	87-A30-663-040	C-TR,2SB792A(RS)	a
MAIN	S	Q 0126	87-A30-663-040	C-TR,2SB792A(RS)	a
MAIN	S	Q 0127	87-A30-076-080	C-TR,2SC3052F	a
MAIN	S	Q 0128	87-A30-076-080	C-TR,2SC3052F	a
MAIN	S	Q 0130	87-A30-662-040	C-TR,2SD814A(RS)	a
MAIN	S	Q 0183	87-A30-162-010	FET,2SK2937	a
MAIN	S	Q 0184	87-A30-162-010	FET,2SK2937	a
MAIN	S	Q 0185	87-A30-076-080	C-TR,2SC3052F	a
MAIN	S	Q 0186	87-A30-075-080	C-TR,2SA1235F	a
MAIN	S	Q 0187	87-A30-075-080	C-TR,2SA1235F	a
MAIN	S	Q 0235	87-A30-075-080	C-TR,2SA1235F	a
MAIN	S	Q 0280	87-A30-538-040	C-TR,SRA2202S	a
MAIN	S	Q 0281	87-A30-663-040	C-TR,2SB792A(RS)	a
MAIN	S	Q 0301	87-A30-091-080	FET,2SJ460	a

ELECTRICAL PARTS LIST - 10/15

! = Δ SAFETY PARTS
 C = Components marked

All components used on this model at the production line are shown in this service manual.

However, please note that not all components will be available as spare parts for after-sales service.

Components marked S and O are designated as spare parts for service and will be stocked at the spare parts centers.

Components marked X and R are not designated as spare parts for after sales service, and will not be stocked at the spare parts centers.

UNIT-NAME	! C	REF-NO	PARTS-NO	PARTS-NAME	SUFFIX&MODEL
					CX-SNR41 EZSC
MAIN	S Q	0302	87-A30-091-080	FET,2SJ460	a
MAIN	S Q	0303	87-A30-090-080	FET,2SK2541	a
MAIN	S Q	0304	87-A30-090-080	FET,2SK2541	a
MAIN	S Q	0305	87-A30-091-080	FET,2SJ460	a
MAIN	S Q	0306	87-A30-091-080	FET,2SJ460	a
MAIN	S Q	0307	87-A30-090-080	FET,2SK2541	a
MAIN	S Q	0308	87-A30-090-080	FET,2SK2541	a
MAIN	S Q	0309	87-A30-090-080	FET,2SK2541	a
MAIN	S Q	0451	87-A30-492-080	TR,2SC5343G	a
MAIN	S Q	0452	87-A30-076-080	C-TR,2SC3052F	a
MAIN	S Q	0453	89-333-317-880	TR,2SC3331(T/U)	a
MAIN	S Q	0454	89-333-317-880	TR,2SC3331(T/U)	a
MAIN	S Q	0455	87-A30-119-040	C-TR,2SC3906K R	a
MAIN	S Q	0456	87-A30-076-080	C-TR,2SC3052F	a
MAIN	S Q	0601	87-A30-538-040	C-TR,SRA2202S	a
MAIN	S Q	0651	87-A30-087-080	C-FET,2SK2158	a
MAIN	S Q	0652	87-A30-087-080	C-FET,2SK2158	a
MAIN	S Q	0653	87-A30-076-080	C-TR,2SC3052F	a
MAIN	S Q	0835	87-A30-521-080	C-TR,2SC5345SF/S(O)	a
MAIN	S Q	0836	87-A30-677-040	C-TR,SRA2207S	a
					CX-SNR41 EZSC
MAIN	S Q	0861	87-A30-076-080	C-TR,2SC3052F	a
MAIN	S Q	0863	87-A30-076-080	C-TR,2SC3052F	a
MAIN	S Q	0901	89-503-602-080	C-FET,2SK360E	a
MAIN	S Q	0902	87-A30-664-080	C-TR,2SC2620B	a
MAIN	S Q	0903	87-A30-664-080	C-TR,2SC2620B	a
MAIN	S Q	0904	87-A30-664-080	C-TR,2SC2620B	a
MAIN	S Q	0905	87-A30-664-080	C-TR,2SC2620B	a
MAIN	S Q	0948	87-A30-675-040	C-TR,2SD1306NE07TL	a
MAIN	S Q	0951	87-A30-538-040	C-TR,SRA2202S	a
MAIN	S Q	0952	87-A30-675-040	C-TR,2SD1306NE07TL	a
MAIN	S Q	0953	89-503-602-080	C-FET,2SK360E	a
MAIN	S Q	0981	87-A30-494-080	TR,2SA1980G	a
MAIN	S Q	0982	87-A30-076-080	C-TR,2SC3052F	a
MAIN	S Q	0983	87-A30-076-080	C-TR,2SC3052F	a
MAIN	X R	0001	88-100-000-010	PLATING-JW, 0.58 SN95	a
MAIN	X R	0005	88-100-000-010	PLATING-JW, 0.58 SN95	a
MAIN	O R	0009	88-108-223-080	C-RES,U 22K-1/16W J	a
MAIN	O R	0010	88-108-223-080	C-RES,U 22K-1/16W J	a
MAIN	X R	0011	88-118-472-080	C-RES,S 4.7K-1/10W J	a
MAIN	X R	0012	88-118-472-080	C-RES,S 4.7K-1/10W J	a
					CX-SNR41 EZSC
MAIN	X R	0013	88-108-472-080	C-RES,U 4.7K-1/16W J	a
MAIN	X R	0014	88-108-100-080	C-RES,U 10-1/16W J	a
MAIN	X R	0015	88-121-104-080	RES,100K-1/8W J	a
MAIN	X R	0018	88-108-104-080	C-RES,U 100K-1/16W J	a
MAIN	X R	0019	88-108-104-080	C-RES,U 100K-1/16W J	a
MAIN	O R	0024	88-108-103-080	C-RES,U 10K-1/16W J	a
MAIN	X R	0026	88-108-472-080	C-RES,U 4.7K-1/16W J	a
MAIN	X R	0027	88-118-000-080	C-JUMPER,S	a
MAIN	X R	0028	88-118-221-080	C-RES,S 220-1/10W J	a
MAIN	O R	0029	88-108-223-080	C-RES,U 22K-1/16W J	a
MAIN	X R	0031	88-121-154-080	RES,150K-1/8W J	a
MAIN	X R	0032	88-108-472-080	C-RES,U 4.7K-1/16W J	a
MAIN	O R	0035	88-108-123-080	C-RES,U 12K-1/16W J	a
MAIN	X R	0037	88-118-102-080	C-RES,S 1K-1/10W J	a
MAIN	X R	0038	88-118-102-080	C-RES,S 1K-1/10W J	a
MAIN	X R	0042	88-121-331-080	RES,330-1/8W J	a
MAIN	X R	0043	88-121-331-080	RES,330-1/8W J	a
MAIN	X R	0044	88-121-331-080	RES,330-1/8W J	a
MAIN	X R	0045	88-121-331-080	RES,330-1/8W J	a
MAIN	X R	0046	88-121-471-080	RES,470-1/8W J	a
					CX-SNR41 EZSC
MAIN	X R	0050	88-108-183-080	C-RES,U 18K-1/16W J	a
MAIN	O R	0051	88-108-102-080	C-RES,U 1K-1/16W J	a
MAIN	O R	0052	88-108-102-080	C-RES,U 1K-1/16W J	a
MAIN	O R	0053	88-108-473-080	C-RES,U 47K-1/16W J	a
MAIN	X R	0054	88-108-682-080	C-RES,U 6.8K-1/16W J	a
MAIN	X R	0055	88-121-152-080	RES,1.5K-1/8W J	a
MAIN	X R	0056	88-108-680-080	C-RES,U 68-1/16W J	a
MAIN	X R	0057	88-108-472-080	C-RES,U 4.7K-1/16W J	a
MAIN	O R	0058	88-108-103-080	C-RES,U 10K-1/16W J	a
MAIN	X R	0059	88-108-221-080	C-RES,U 220-1/16W J	a
MAIN	X R	0060	88-108-471-080	C-RES,U 470-1/16W J	a
MAIN	O R	0061	88-108-103-080	C-RES,U 10K-1/16W J	a
MAIN	O R	0062	88-108-223-080	C-RES,U 22K-1/16W J	a
MAIN	O R	0063	88-108-223-080	C-RES,U 22K-1/16W J	a
MAIN	O R	0064	88-108-103-080	C-RES,U 10K-1/16W J	a
MAIN	O R	0065	88-108-123-080	C-RES,U 12K-1/16W J	a
MAIN	X R	0066	88-108-104-080	C-RES,U 100K-1/16W J	a
MAIN	O R	0067	88-108-103-080	C-RES,U 10K-1/16W J	a
MAIN	X R	0068	88-128-152-080	C-RES, 1.5K-1/8W J	a
MAIN	O R	0076	88-108-103-080	C-RES,U 10K-1/16W J	a

ELECTRICAL PARTS LIST - 11/15

! = Δ SAFETY PARTS
 C = Components marked

All components used on this model at the production line are shown in this service manual.

However, please note that not all components will be available as spare parts for after-sales service.

Components marked S and O are designated as spare parts for service and will be stocked at the spare parts centers.

Components marked X and R are not designated as spare parts for after sales service, and will not be stocked at the spare parts centers.

UNIT-NAME	! C	REF-NO	PARTS-NO	PARTS-NAME	SUFFIX&MODEL
					CX-SNR41 EZSC
MAIN	X R	0078	88-108-393-080	C-RES,U 39K-1/16W J	a
MAIN	O R	0079	88-108-103-080	C-RES,U 10K-1/16W J	a
MAIN	O R	0081	88-108-101-080	C-RES,U 100-1/16W J	a
MAIN	O R	0085	88-108-103-080	C-RES,U 10K-1/16W J	a
MAIN	O R	0093	88-108-823-080	C-RES,U 82K-1/16W J	a
MAIN	X R	0094	88-108-393-080	C-RES,U 39K-1/16W J	a
MAIN	O R	0095	88-108-103-080	C-RES,U 10K-1/16W J	a
MAIN	O R	0096	88-108-823-080	C-RES,U 82K-1/16W J	a
MAIN	X R	0103	88-108-393-080	C-RES,U 39K-1/16W J	a
MAIN	X R	0104	88-108-393-080	C-RES,U 39K-1/16W J	a
MAIN	X R	0105	88-108-273-080	C-RES,U 27K-1/16W J	a
MAIN	X R	0106	88-108-273-080	C-RES,U 27K-1/16W J	a
MAIN	O R	0107	88-108-101-080	C-RES,U 100-1/16W J	a
MAIN	O R	0108	88-108-101-080	C-RES,U 100-1/16W J	a
MAIN	O R	0111	88-108-102-080	C-RES,U 1K-1/16W J	a
MAIN	O R	0112	88-108-102-080	C-RES,U 1K-1/16W J	a
MAIN	X R	0113	88-118-273-080	C-RES,S 27K-1/10W J	a
MAIN	X R	0114	88-118-273-080	C-RES,S 27K-1/10W J	a
MAIN	X R	0115	88-128-222-080	C-RES, 2.2K-1/8W J	a
MAIN	X R	0116	88-128-222-080	C-RES, 2.2K-1/8W J	a
					CX-SNR41 EZSC
MAIN	O R	0117	88-108-103-080	C-RES,U 10K-1/16W J	a
MAIN	O R	0118	88-108-103-080	C-RES,U 10K-1/16W J	a
MAIN	O R	0119	88-108-101-080	C-RES,U 100-1/16W J	a
MAIN	O R	0120	88-108-101-080	C-RES,U 100-1/16W J	a
MAIN	O R	0121	88-108-101-080	C-RES,U 100-1/16W J	a
MAIN	O R	0122	88-108-101-080	C-RES,U 100-1/16W J	a
MAIN	X R	0123	88-128-222-080	C-RES, 2.2K-1/8W J	a
MAIN	X R	0124	88-128-222-080	C-RES, 2.2K-1/8W J	a
MAIN	X R	0125	88-128-102-080	C-RES, 1K-1/8W J	a
MAIN	X R	0126	88-128-102-080	C-RES, 1K-1/8W J	a
MAIN	X R	0127	88-108-390-080	C-RES,U 39-1/16W J	a
MAIN	X R	0128	88-108-390-080	C-RES,U 39-1/16W J	a
MAIN	O R	0129	87-A00-262-080	RES,M/F 0.15-2W J	a
MAIN	O R	0130	87-A00-262-080	RES,M/F 0.15-2W J	a
MAIN	O R	0131	87-A00-262-080	RES,M/F 0.15-2W J	a
MAIN	O R	0132	87-A00-262-080	RES,M/F 0.15-2W J	a
MAIN	X R	0133	88-108-472-080	C-RES,U 4.7K-1/16W J	a
MAIN	X R	0134	88-108-472-080	C-RES,U 4.7K-1/16W J	a
MAIN	X R	0135	88-108-122-080	C-RES,U 1.2K-1/16W J	a
MAIN	X R	0136	88-108-122-080	C-RES,U 1.2K-1/16W J	a
					CX-SNR41 EZSC
MAIN	O R	0137	88-108-101-080	C-RES,U 100-1/16W J	a
MAIN	O R	0138	88-108-101-080	C-RES,U 100-1/16W J	a
MAIN	X R	0141	88-118-102-080	C-RES,S 1K-1/10W J	a
MAIN	X R	0142	88-118-102-080	C-RES,S 1K-1/10W J	a
MAIN	X R	0143	88-108-392-080	C-RES,U 3.9K-1/16W J	a
MAIN	O R	0145	88-108-123-080	C-RES,U 12K-1/16W J	a
MAIN	O R	0146	88-108-123-080	C-RES,U 12K-1/16W J	a
MAIN	X R	0149	88-108-392-080	C-RES,U 3.9K-1/16W J	a
MAIN	O R	0151	88-108-473-080	C-RES,U 47K-1/16W J	a
MAIN	O R	0152	88-108-473-080	C-RES,U 47K-1/16W J	a
MAIN	X R	0153	88-128-272-080	C-RES, 2.7K-1/8W J	a
MAIN	O R	0155	88-108-822-080	C-RES,U 8.2K-1/16W J	a
MAIN	O R	0156	88-108-822-080	C-RES,U 8.2K-1/16W J	a
MAIN	X R	0157	88-108-472-080	C-RES,U 4.7K-1/16W J	a
MAIN	X R	0158	88-108-472-080	C-RES,U 4.7K-1/16W J	a
MAIN	O R	0159	88-108-103-080	C-RES,U 10K-1/16W J	a
MAIN	X R	0160	88-121-103-080	RES,10K-1/8W J	a
MAIN	X R	0161	88-108-472-080	C-RES,U 4.7K-1/16W J	a
MAIN	X R	0162	88-108-472-080	C-RES,U 4.7K-1/16W J	a
MAIN	X R	0163	88-108-472-080	C-RES,U 4.7K-1/16W J	a
					CX-SNR41 EZSC
MAIN	X R	0164	88-108-472-080	C-RES,U 4.7K-1/16W J	a
MAIN	X R	0165	88-108-152-080	C-RES,U 1.5K-1/16W J	a
MAIN	X R	0166	88-108-152-080	C-RES,U 1.5K-1/16W J	a
MAIN	O R	0167	88-108-103-080	C-RES,U 10K-1/16W J	a
MAIN	O R	0168	88-108-473-080	C-RES,U 47K-1/16W J	a
MAIN	X R	0171	88-108-222-080	C-RES,U 2.2K-1/16W J	a
MAIN	X R	0172	88-108-222-080	C-RES,U 2.2K-1/16W J	a
MAIN	X R	0173	88-108-182-080	C-RES,U 1.8K-1/16W J	a
MAIN	X R	0174	88-108-182-080	C-RES,U 1.8K-1/16W J	a
MAIN	X R	0175	88-108-331-080	C-RES,U 330-1/16W J	a
MAIN	X R	0176	88-108-331-080	C-RES,U 330-1/16W J	a
MAIN	X R	0177	88-128-222-080	C-RES, 2.2K-1/8W J	a
MAIN	O R	0178	88-108-103-080	C-RES,U 10K-1/16W J	a
MAIN	O R	0179	88-108-102-080	C-RES,U 1K-1/16W J	a
MAIN	O R	0180	88-108-102-080	C-RES,U 1K-1/16W J	a
MAIN	X R	0181	88-108-222-080	C-RES,U 2.2K-1/16W J	a
MAIN	X R	0182	88-108-222-080	C-RES,U 2.2K-1/16W J	a
MAIN	X R	0184	88-118-102-080	C-RES,S 1K-1/10W J	a
MAIN	O R	0185	88-108-332-080	C-RES,U 3.3K-1/16W J	a
MAIN	X R	0186	88-118-102-080	C-RES,S 1K-1/10W J	a

ELECTRICAL PARTS LIST - 12/15

! = SAFETY PARTS
 C = Components marked

All components used on this model at the production line are shown in this service manual.
 However, please note that not all components will be available as spare parts for after-sales service.
 Components marked S and O are designated as spare parts for service and will be stocked at the spare parts centers.
 Components marked X and R are not designated as spare parts for after sales service, and will not be stocked at the spare parts centers.

UNIT-NAME	! C	REF-NO	PARTS-NO	PARTS-NAME	SUFFIX&MODEL
					CX-SNR41 EZSC
MAIN	X R	0187	88-118-103-080	C-RES,S 10K-1/10W J	a
MAIN	X R	0188	88-118-222-080	C-RES,S 2.2K-1/10W J	a
MAIN	X R	0189	88-128-272-080	C-RES, 2.7K-1/8W J	a
MAIN	X R	0190	88-128-272-080	C-RES, 2.7K-1/8W J	a
MAIN	X R	0192	88-128-222-080	C-RES, 2.2K-1/8W J	a
MAIN	O R	0193	88-108-103-080	C-RES,U 10K-1/16W J	a
MAIN	O R	0194	88-108-103-080	C-RES,U 10K-1/16W J	a
MAIN	O R	0195	88-108-473-080	C-RES,U 47K-1/16W J	a
MAIN	O R	0196	88-108-473-080	C-RES,U 47K-1/16W J	a
MAIN	O R	0197	88-108-473-080	C-RES,U 47K-1/16W J	a
MAIN	O R	0198	88-108-473-080	C-RES,U 47K-1/16W J	a
MAIN	X R	0199	88-108-225-080	C-RES,U 2.2M-1/16W J	a
MAIN	X R	0217	88-108-683-080	C-RES,U 68K-1/16W J	a
MAIN	X R	0218	88-108-105-080	C-RES,U 1M-1/16W J	a
MAIN	X R	0219	88-108-000-080	C-JUMPER,U	a
MAIN	X R	0247	88-130-100-080	RES,10-1/4W J	a
MAIN	X R	0248	88-130-100-080	RES,10-1/4W J	a
MAIN	X R	0249	88-128-100-080	C-RES, 10-1/8W J	a
MAIN	X R	0250	88-128-100-080	C-RES, 10-1/8W J	a
MAIN	O R	0280	88-108-473-080	C-RES,U 47K-1/16W J	a
					CX-SNR41 EZSC
MAIN	X R	0281	88-108-222-080	C-RES,U 2.2K-1/16W J	a
MAIN	O R	0282	88-108-103-080	C-RES,U 10K-1/16W J	a
MAIN	O R	0283	88-108-224-080	C-RES,U 220K-1/16W J	a
MAIN	O R	0284	88-108-224-080	C-RES,U 220K-1/16W J	a
MAIN	O R	0285	88-108-223-080	C-RES,U 22K-1/16W J	a
MAIN	O R	0286	88-108-473-080	C-RES,U 47K-1/16W J	a
MAIN	O R	0287	88-108-473-080	C-RES,U 47K-1/16W J	a
MAIN	X R	0301	88-108-393-080	C-RES,U 39K-1/16W J	a
MAIN	X R	0302	88-108-393-080	C-RES,U 39K-1/16W J	a
MAIN	O R	0303	88-108-823-080	C-RES,U 82K-1/16W J	a
MAIN	O R	0304	88-108-823-080	C-RES,U 82K-1/16W J	a
MAIN	O R	0305	88-108-224-080	C-RES,U 220K-1/16W J	a
MAIN	X R	0451	88-108-222-080	C-RES,U 2.2K-1/16W J	a
MAIN	X R	0453	88-108-472-080	C-RES,U 4.7K-1/16W J	a
MAIN	X R	0454	88-121-829-080	RES,8.2-1/8W J	a
MAIN	X R	0455	88-108-183-080	C-RES,U 18K-1/16W J	a
MAIN	X R	0456	88-108-183-080	C-RES,U 18K-1/16W J	a
MAIN	X R	0457	88-108-104-080	C-RES,U 100K-1/16W J	a
MAIN	O R	0458	88-108-563-080	C-RES,U 56K-1/16W J	a
MAIN	X R	0459	88-108-472-080	C-RES,U 4.7K-1/16W J	a
					CX-SNR41 EZSC
MAIN	X R	0461	88-108-472-080	C-RES,U 4.7K-1/16W J	a
MAIN	X R	0462	88-108-471-080	C-RES,U 470-1/16W J	a
MAIN	X R	0467	88-108-472-080	C-RES,U 4.7K-1/16W J	a
MAIN	O R	0468	88-108-272-080	C-RES,U 2.7K-1/16W J	a
MAIN	X R	0469	88-108-150-080	C-RES,U 15-1/16W J	a
MAIN	X R	0601	88-108-680-080	C-RES,U 68-1/16W J	a
MAIN	X R	0602	88-108-680-080	C-RES,U 68-1/16W J	a
MAIN	X R	0603	88-108-394-080	C-RES,U 390K-1/16W J	a
MAIN	X R	0604	88-108-394-080	C-RES,U 390K-1/16W J	a
MAIN	X R	0605	88-108-122-080	C-RES,U 1.2K-1/16W J	a
MAIN	X R	0606	88-108-122-080	C-RES,U 1.2K-1/16W J	a
MAIN	X R	0607	88-108-183-080	C-RES,U 18K-1/16W J	a
MAIN	X R	0608	88-108-183-080	C-RES,U 18K-1/16W J	a
MAIN	X R	0609	88-108-472-080	C-RES,U 4.7K-1/16W J	a
MAIN	X R	0610	88-108-472-080	C-RES,U 4.7K-1/16W J	a
MAIN	O R	0611	88-108-223-080	C-RES,U 22K-1/16W J	a
MAIN	O R	0612	88-108-223-080	C-RES,U 22K-1/16W J	a
MAIN	X R	0613	88-108-273-080	C-RES,U 27K-1/16W J	a
MAIN	X R	0614	88-108-273-080	C-RES,U 27K-1/16W J	a
MAIN	O R	0615	88-108-153-080	C-RES,U 15K-1/16W J	a
					CX-SNR41 EZSC
MAIN	O R	0616	88-108-153-080	C-RES,U 15K-1/16W J	a
MAIN	O R	0617	88-108-153-080	C-RES,U 15K-1/16W J	a
MAIN	O R	0619	88-108-153-080	C-RES,U 15K-1/16W J	a
MAIN	O R	0621	88-108-332-080	C-RES,U 3.3K-1/16W J	a
MAIN	O R	0622	88-108-332-080	C-RES,U 3.3K-1/16W J	a
MAIN	O R	0623	88-108-332-080	C-RES,U 3.3K-1/16W J	a
MAIN	O R	0624	88-108-332-080	C-RES,U 3.3K-1/16W J	a
MAIN	O R	0625	88-108-103-080	C-RES,U 10K-1/16W J	a
MAIN	O R	0626	88-108-103-080	C-RES,U 10K-1/16W J	a
MAIN	X R	0627	88-108-222-080	C-RES,U 2.2K-1/16W J	a
MAIN	X R	0628	88-108-222-080	C-RES,U 2.2K-1/16W J	a
MAIN	O R	0629	88-108-103-080	C-RES,U 10K-1/16W J	a
MAIN	O R	0630	88-108-103-080	C-RES,U 10K-1/16W J	a
MAIN	X R	0631	88-108-222-080	C-RES,U 2.2K-1/16W J	a
MAIN	X R	0632	88-108-222-080	C-RES,U 2.2K-1/16W J	a
MAIN	O R	0633	88-108-272-080	C-RES,U 2.7K-1/16W J	a
MAIN	O R	0634	88-108-272-080	C-RES,U 2.7K-1/16W J	a
MAIN	O R	0635	88-108-102-080	C-RES,U 1K-1/16W J	a
MAIN	O R	0636	88-108-102-080	C-RES,U 1K-1/16W J	a
MAIN	O R	0637	88-108-102-080	C-RES,U 1K-1/16W J	a

ELECTRICAL PARTS LIST - 13/15

! = SAFETY PARTS

C = Components marked

All components used on this model at the production line are shown in this service manual.

However, please note that not all components will be available as spare parts for after-sales service.

Components marked S and O are designated as spare parts for service and will be stocked at the spare parts centers.

Components marked X and R are not designated as spare parts for after sales service, and will not be stocked at the spare parts centers.

UNIT-NAME	! C	REF-NO	PARTS-NO	PARTS-NAME	SUFFIX&MODEL
					CX-SNR41 EZSC
MAIN	O R	0638	88-108-102-080	C-RES,U 1K-1/16W J	a
MAIN	X R	0639	88-108-183-080	C-RES,U 18K-1/16W J	a
MAIN	X R	0640	88-108-183-080	C-RES,U 18K-1/16W J	a
MAIN	X R	0641	88-121-223-080	RES,22K-1/8W J	a
MAIN	X R	0642	88-108-222-080	C-RES,U 2.2K-1/16W J	a
MAIN	X R	0643	88-108-104-080	C-RES,U 100K-1/16W J	a
MAIN	X R	0644	88-108-104-080	C-RES,U 100K-1/16W J	a
MAIN	O R	0649	88-108-332-080	C-RES,U 3.3K-1/16W J	a
MAIN	O R	0650	88-108-332-080	C-RES,U 3.3K-1/16W J	a
MAIN	O R	0651	88-108-101-080	C-RES,U 100-1/16W J	a
MAIN	O R	0652	88-108-101-080	C-RES,U 100-1/16W J	a
MAIN	X R	0656	88-121-394-080	RES,390K-1/8W J	a
MAIN	X R	0657	88-108-274-080	C-RES,U 270K-1/16W J	a
MAIN	X R	0658	88-108-274-080	C-RES,U 270K-1/16W J	a
MAIN	X R	0659	88-108-394-080	C-RES,U 390K-1/16W J	a
MAIN	X R	0660	88-108-274-080	C-RES,U 270K-1/16W J	a
MAIN	X R	0661	88-108-392-080	C-RES,U 3.9K-1/16W J	a
MAIN	X R	0662	88-108-392-080	C-RES,U 3.9K-1/16W J	a
MAIN	O R	0672	88-108-223-080	C-RES,U 22K-1/16W J	a
MAIN	X R	0673	88-108-392-080	C-RES,U 3.9K-1/16W J	a
					CX-SNR41 EZSC
MAIN	X R	0674	88-108-273-080	C-RES,U 27K-1/16W J	a
MAIN	O R	0677	88-108-223-080	C-RES,U 22K-1/16W J	a
MAIN	O R	0678	88-108-223-080	C-RES,U 22K-1/16W J	a
MAIN	X R	0789	88-108-273-080	C-RES,U 27K-1/16W J	a
MAIN	O R	0790	87-012-286-080	C-CAP,U 0.01-25 K B GRM	a
MAIN	O R	0791	88-108-102-080	C-RES,U 1K-1/16W J	a
MAIN	X R	0793	88-108-221-080	C-RES,U 220-1/16W J	a
MAIN	X R	0795	88-108-000-080	C-JUMPER,U	a
MAIN	O R	0801	88-108-103-080	C-RES,U 10K-1/16W J	a
MAIN	O R	0802	88-108-223-080	C-RES,U 22K-1/16W J	a
MAIN	X R	0803	88-128-183-080	C-RES, 18K-1/8W J	a
MAIN	X R	0804	88-108-000-080	C-JUMPER,U	a
MAIN	O R	0805	88-108-332-080	C-RES,U 3.3K-1/16W J	a
MAIN	X R	0806	88-108-682-080	C-RES,U 6.8K-1/16W J	a
MAIN	O R	0809	88-108-102-080	C-RES,U 1K-1/16W J	a
MAIN	O R	0810	88-108-102-080	C-RES,U 1K-1/16W J	a
MAIN	X R	0811	88-108-000-080	C-JUMPER,U	a
MAIN	X R	0812	88-108-000-080	C-JUMPER,U	a
MAIN	O R	0813	88-108-224-080	C-RES,U 220K-1/16W J	a
MAIN	X R	0814	88-108-222-080	C-RES,U 2.2K-1/16W J	a
					CX-SNR41 EZSC
MAIN	X R	0815	88-121-682-080	RES,6.8K-1/8W J	a
MAIN	O R	0818	88-108-103-080	C-RES,U 10K-1/16W J	a
MAIN	X R	0821	88-108-000-080	C-JUMPER,U	a
MAIN	O R	0823	88-108-473-080	C-RES,U 47K-1/16W J	a
MAIN	O R	0826	88-108-223-080	C-RES,U 22K-1/16W J	a
MAIN	X R	0832	88-108-391-080	C-RES,U 390-1/16W J	a
MAIN	X R	0840	88-108-331-080	C-RES,U 330-1/16W J	a
MAIN	O R	0850	88-108-103-080	C-RES,U 10K-1/16W J	a
MAIN	X R	0851	88-118-470-080	C-RES,S 47-1/10W J	a
MAIN	O R	0853	88-108-102-080	C-RES,U 1K-1/16W J	a
MAIN	X R	0854	88-108-331-080	C-RES,U 330-1/16W J	a
MAIN	X R	0855	88-108-183-080	C-RES,U 18K-1/16W J	a
MAIN	O R	0856	88-108-103-080	C-RES,U 10K-1/16W J	a
MAIN	X R	0857	88-108-181-080	C-RES,U 180-1/16W J	a
MAIN	X R	0858	88-108-271-080	C-RES,U 270-1/16W J	a
MAIN	O R	0860	88-108-101-080	C-RES,U 100-1/16W J	a
MAIN	X R	0861	88-108-471-080	C-RES,U 470-1/16W J	a
MAIN	O R	0862	88-108-272-080	C-RES,U 2.7K-1/16W J	a
MAIN	X R	0863	88-108-104-080	C-RES,U 100K-1/16W J	a
MAIN	O R	0864	88-108-123-080	C-RES,U 12K-1/16W J	a
					CX-SNR41 EZSC
MAIN	X R	0865	88-108-471-080	C-RES,U 470-1/16W J	a
MAIN	X R	0867	88-108-104-080	C-RES,U 100K-1/16W J	a
MAIN	X R	0870	88-121-102-080	RES,1K-1/8W J	a
MAIN	X R	0871	88-121-102-080	RES,1K-1/8W J	a
MAIN	X R	0901	88-108-104-080	C-RES,U 100K-1/16W J	a
MAIN	X R	0902	88-108-104-080	C-RES,U 100K-1/16W J	a
MAIN	X R	0903	88-108-330-080	C-RES,U 33-1/16W J	a
MAIN	O R	0904	88-108-103-080	C-RES,U 10K-1/16W J	a
MAIN	O R	0905	88-108-102-080	C-RES,U 1K-1/16W J	a
MAIN	X R	0906	88-108-564-080	C-RES,U 560K-1/16W J	a
MAIN	X R	0908	88-108-271-080	C-RES,U 270-1/16W J	a
MAIN	X R	0909	88-108-181-080	C-RES,U 180-1/16W J	a
MAIN	X R	0910	88-108-334-080	C-RES,U 330K-1/16W J	a
MAIN	X R	0911	88-108-181-080	C-RES,U 180-1/16W J	a
MAIN	X R	0912	88-108-104-080	C-RES,U 100K-1/16W J	a
MAIN	X R	0913	88-108-152-080	C-RES,U 1.5K-1/16W J	a
MAIN	X R	0914	88-108-472-080	C-RES,U 4.7K-1/16W J	a
MAIN	X R	0915	88-108-104-080	C-RES,U 100K-1/16W J	a
MAIN	X R	0916	88-108-470-080	C-RES,U 47-1/16W J	a
MAIN	O R	0926	88-108-101-080	C-RES,U 100-1/16W J	a

ELECTRICAL PARTS LIST - 14/15

! = SAFETY PARTS
 C = Components marked

All components used on this model at the production line are shown in this service manual.

However, please note that not all components will be available as spare parts for after-sales service.

Components marked S and O are designated as spare parts for service and will be stocked at the spare parts centers.

Components marked X and R are not designated as spare parts for after sales service, and will not be stocked at the spare parts centers.

UNIT-NAME	! C	REF-NO	PARTS-NO	PARTS-NAME	SUFFIX&MODEL
					CX-SNR41 EZSC
MAIN		O R	0944 88-108-101-080	C-RES,U 100-1/16W J	a
MAIN		X R	0945 88-108-104-080	C-RES,U 100K-1/16W J	a
MAIN		X R	0947 88-108-183-080	C-RES,U 18K-1/16W J	a
MAIN		X R	0948 88-108-472-080	C-RES,U 4.7K-1/16W J	a
MAIN		O R	0952 88-108-562-080	C-RES,U 5.6K-1/16W J	a
MAIN		X R	0954 88-108-222-080	C-RES,U 2.2K-1/16W J	a
MAIN		X R	0956 88-108-471-080	C-RES,U 470-1/16W J	a
MAIN		X R	0958 88-108-472-080	C-RES,U 4.7K-1/16W J	a
MAIN		O R	0959 88-108-103-080	C-RES,U 10K-1/16W J	a
MAIN		X R	0962 88-121-102-080	RES,1K-1/8W J	a
MAIN		X R	0964 88-108-330-080	C-RES,U 33-1/16W J	a
MAIN		O R	0968 88-108-822-080	C-RES,U 8.2K-1/16W J	a
MAIN		O R	0969 88-108-102-080	C-RES,U 1K-1/16W J	a
MAIN		O R	0973 88-108-102-080	C-RES,U 1K-1/16W J	a
MAIN		O R	0975 88-108-562-080	C-RES,U 5.6K-1/16W J	a
MAIN		O R	0976 88-108-102-080	C-RES,U 1K-1/16W J	a
MAIN		O R	0977 88-108-102-080	C-RES,U 1K-1/16W J	a
MAIN		X R	0978 88-108-681-080	C-RES,U 680-1/16W J	a
MAIN		O R	0979 88-108-123-080	C-RES,U 12K-1/16W J	a
MAIN		X R	0980 88-108-684-080	C-RES,U 680K-1/16W J	a
					CX-SNR41 EZSC
MAIN		X R	0981 88-121-471-080	RES,470-1/8W J	a
MAIN		X R	0982 88-108-682-080	C-RES,U 6.8K-1/16W J	a
MAIN		X R	0983 88-108-392-080	C-RES,U 3.9K-1/16W J	a
MAIN		O R	0984 88-108-562-080	C-RES,U 5.6K-1/16W J	a
MAIN		X R	0985 88-121-471-080	RES,470-1/8W J	a
MAIN		X R	0986 88-121-221-080	RES,220-1/8W J	a
MAIN		X R	0987 88-121-472-080	RES,4.7K-1/8W J	a
MAIN		O R	0988 88-108-103-080	C-RES,U 10K-1/16W J	a
MAIN		X R	0989 88-121-102-080	RES,1K-1/8W J	a
MAIN		O R	0990 88-108-563-080	C-RES,U 56K-1/16W J	a
MAIN		O R	0991 87-012-195-080	C-CAP,U 100P-50 J CH GRM	a
MAIN		O R	0992 88-108-103-080	C-RES,U 10K-1/16W J	a
MAIN		O R	0993 87-012-195-080	C-CAP,U 100P-50 J CH GRM	a
MAIN		O R	0994 88-108-103-080	C-RES,U 10K-1/16W J	a
MAIN		O R	0995 87-012-195-080	C-CAP,U 100P-50 J CH GRM	a
MAIN		O R	0996 88-108-103-080	C-RES,U 10K-1/16W J	a
MAIN		X R	0997 88-108-154-080	C-RES,U 150K-1/16W J	a
MAIN		O R	0998 88-108-102-080	C-RES,U 1K-1/16W J	a
MAIN		O R	0999 88-108-103-080	C-RES,U 10K-1/16W J	a
MAIN		O	SFR0451 87-024-435-080	SFR,33K H RH063MC	a
					CX-SNR41 EZSC
MAIN		O	SFR0452 87-024-435-080	SFR,33K H RH063MC	a
MAIN		X SH	0901 8B-ZA3-619-010	SHLD-CASE,BZA-3 EZ	a
MAIN		O TC	0942 87-A91-774-080	TRIMMER,PLY 30P 6.8X5.4 CDYL	a
MAIN		O TH	0101 87-A91-042-080	C-THMS,100K 55001	a
MAIN		O TH	0102 87-A91-042-080	C-THMS,100K 55001	a
MAIN		O W	0099 8A-NF9-609-010	F-CABLE,9P 2.5 480MM	a
MAIN		O W	0101 8B-NF1-640-010	F-CABLE,5P 2.5 250MM	a
MAIN		O WH	0001 87-A90-510-010	HLDR,WIRE 2.5-9P	a
MAIN		O WH	0101 87-A90-459-010	HLDR,WIRE 2.5-5P	a
MAIN		O X	0862 87-A70-307-010	VIB,XTAL 4.332MHZ CSA-309ST	a
MAIN		O X	0992 87-A70-306-010	VIB,XTAL 4.500MHZ CSA-309ST	a
PT		O C	0091 87-012-368-080	C-CAP,S 0.1-50 Z F GRM	a
PT		S D	0091 87-A40-269-080	C-DIODE,MC2836	a
PT		S D	0092 87-A40-270-080	C-DIODE,MC2838	a
PT		X PR	0003 88-100-000-010	PLATING-JW, 0.58 SN95	a
PT		! O PT	0001 8C-NF7-608-010	PT,CNF-7 EZ	a
PT		! O PT	0002 8C-NF8-655-010	PT,SUB EZ YKP01246B	a
PT		! O RY	0001 87-A91-418-010	RELAY,AC 12V G5PA-1-M	a
PT		! O T	0001 87-A60-317-010	TERMINAL, 1P MSC	a
PT		! O T	0002 87-A60-317-010	TERMINAL, 1P MSC	a
					CX-SNR41 EZSC
PT		O WH	0002 87-A90-510-010	HLDR,WIRE 2.5-9P	a

- Regarding connectors, they are not stocked as they are not the initial order items.
The connectors are available after they are supplied from connector manufacturers upon the order is received.

○チップ抵抗部品コード／CHIP RESISTOR PART CODE

チップ抵抗部品コードの成り立ち

Chip Resistor Part Coding

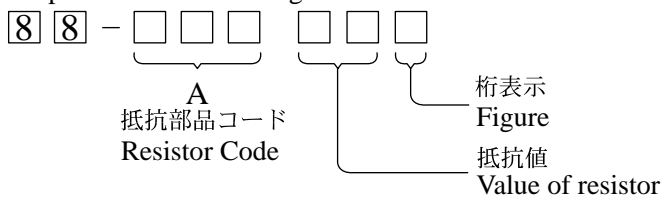

チップ抵抗
Chip resistor

容量 Wattage	種類 Type	許容誤差 Tolerance	記号 Symbol	寸法/Dimensions (mm)			抵抗コード : A Resistor Code : A	
				外形/Form	L	W		t
1/16W	1005	± 5%	CJ		1.0	0.5	0.35	104
1/16W	1608	± 5%	CJ		1.6	0.8	0.45	108
1/10W	2125	± 5%	CJ		2	1.25	0.45	118
1/8W	3216	± 5%	CJ		3.2	1.6	0.55	128

TRANSISTOR ILLUSTRATION -1/1

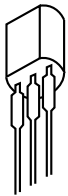

E C B

2SA1980G
2SC5343G

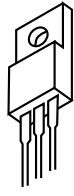

B C E

2SB1548
2SB1686
2SD2642



E C B

2SA1585SR



E C B

2SC3331(T/U)
2SC3478LK
2SC5343GL



E C B

2SA1981Y

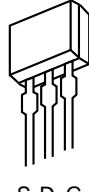

S D G

2SK2541
2SJ460



G D S

2SK2937

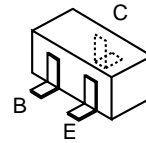

SRA2202S 2SC3906KR
SRA2207S 2SC5345SF/S(O)
2SA1235F 2SD814A(RS)
2SB792A(RS) 2SD1306E
2SC2620B 2SD1306NE
2SC3052F

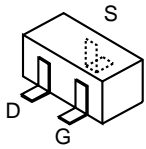

2SK360E

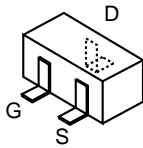

2SK2158

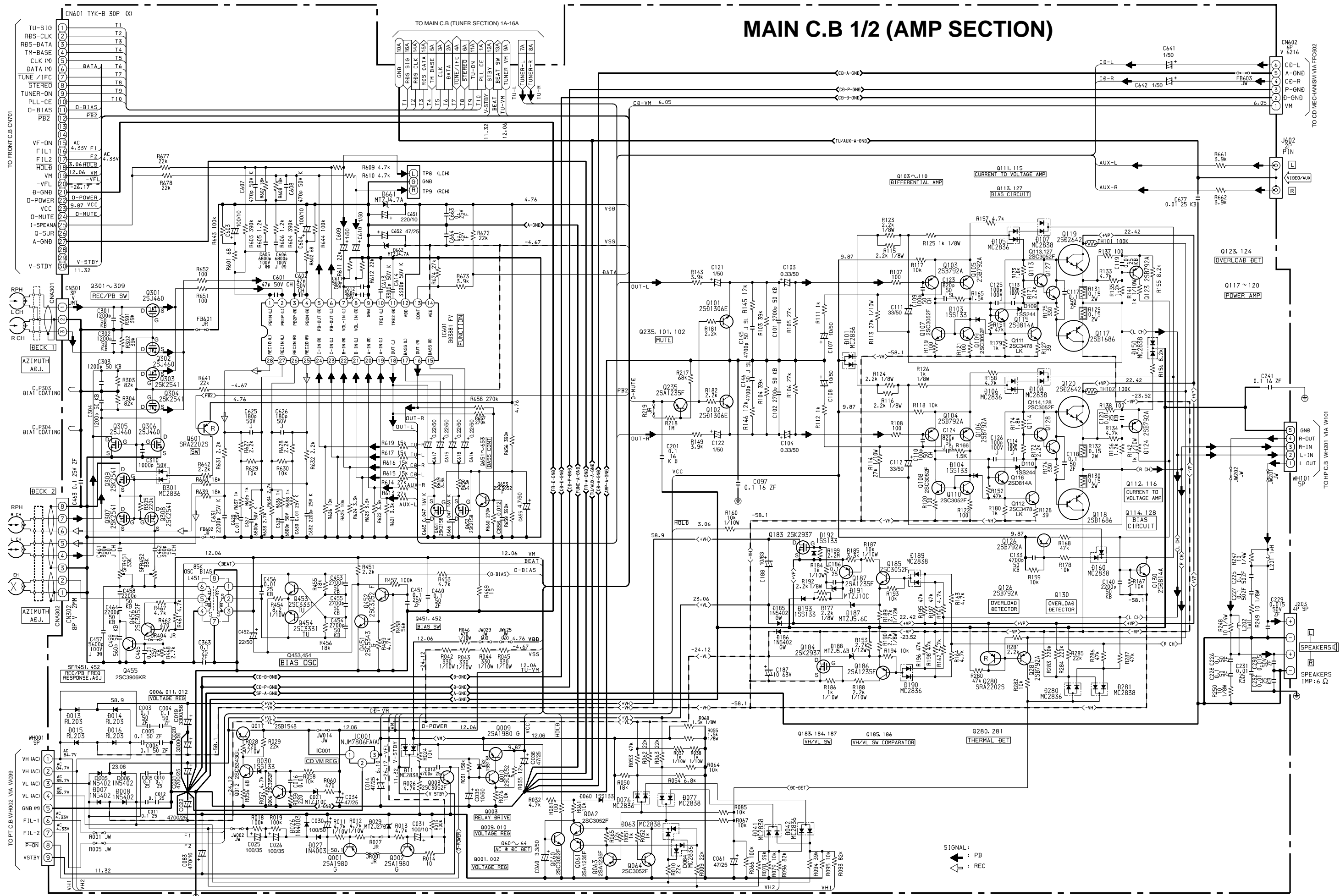

MAIN C.B 1/2 (AMP SECTION)

MAIN C.B 2/2 (TUNER SECTION)

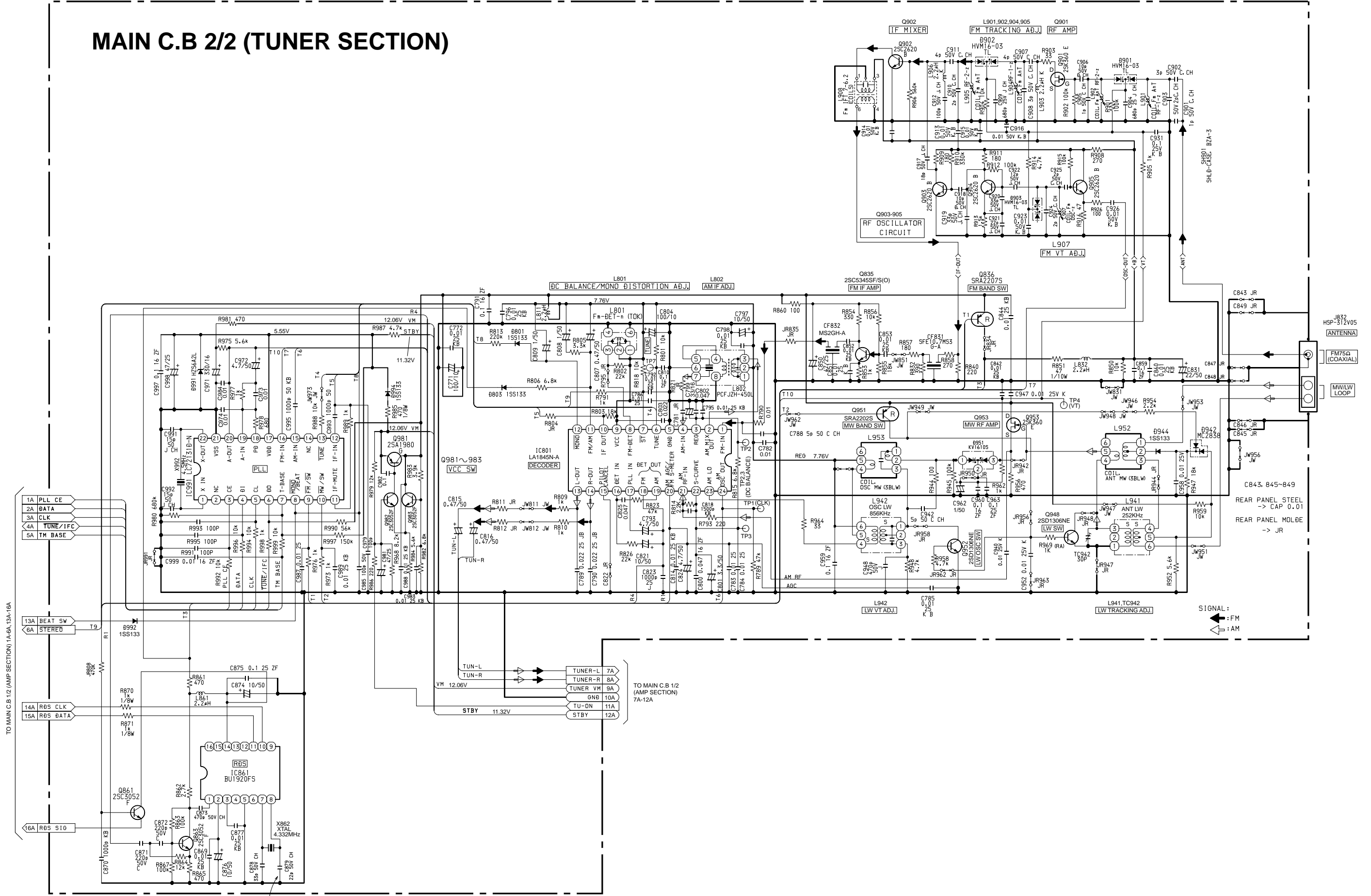

BLUE MEANS...
RBS USING.

SCHEMATIC DIAGRAM -3/5 (HP SECTION)

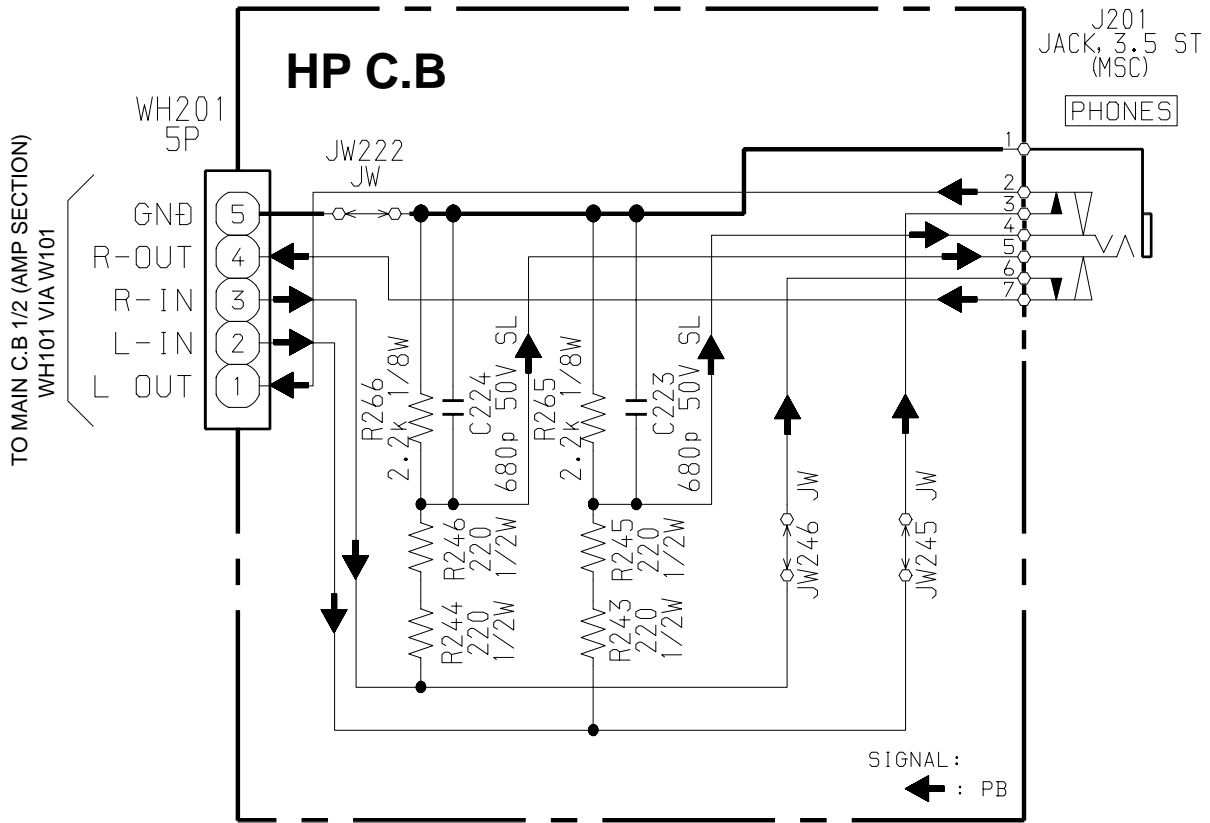

WIRING - 2/4 (FRONT C.B)

32 31 30 29 28 27 26 25 24 23 22 21 20 19 18 17 16 15 14 13 12 11 10 9 8 7 6 5 4 3 2 1

A
B
C
D
E
F
G
H
I
J
K
L
M
N
O
P
Q
R
S
T
U

S333, LED204 S332, LED203 S331, LED202

DISC DIRECT PLAY

IC961
REMOTE
SENSOR

FRONT C.B

FL901
DISPLAY

LED201
POWER ϕ STANDBY/ON

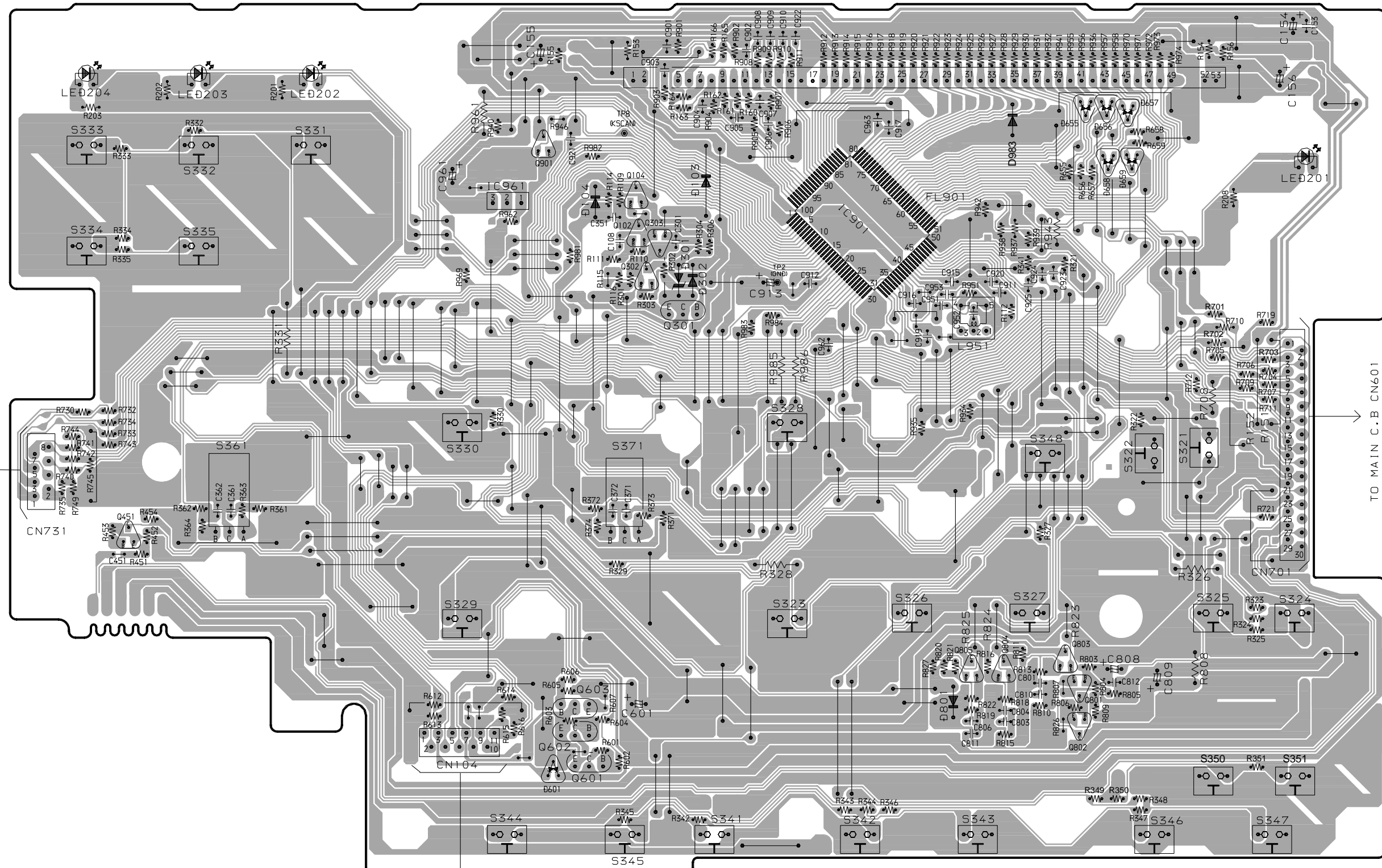

S334
▲ CD OPEN/CLOSE

S335
DISC CHANGE

S361
VOLUME

TO CD MECHANISM BZG-2
(FFC731)

TO MAIN C.B CN601

(FFC104) S330
TO DECK C.B CN1
ENTER

S371
MULTI JOG

S328
DISPLAY

S326
CD

S348
TIMER

S322
DEMO/ECO

S321
POWER ϕ STANDBY/ON

S329
TREBLE

S345
T-BASS

S342
VIDEO/AUX

S327
TUNER/BAND

S325
TAPE/DECK 1/2

S344
UP TUNING

STOP/CLEAR

S341
PLAY/PRESET

S343
PAUSE/SET

S346
REC/REC MUTE

S347
SYNC DUB

[RDS]
S350
PTY
S351
RT

32	31	30	29	28	27	26	25	24	23	22	21	20	19	18	17	16	15	14	13	12	11	10	9	8	7	6	5	4	3	2	1
----	----	----	----	----	----	----	----	----	----	----	----	----	----	----	----	----	----	----	----	----	----	----	---	---	---	---	---	---	---	---	---

DECK C. B

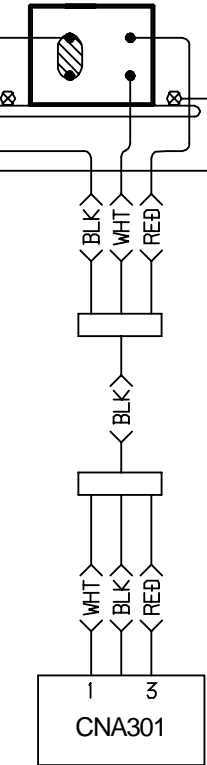
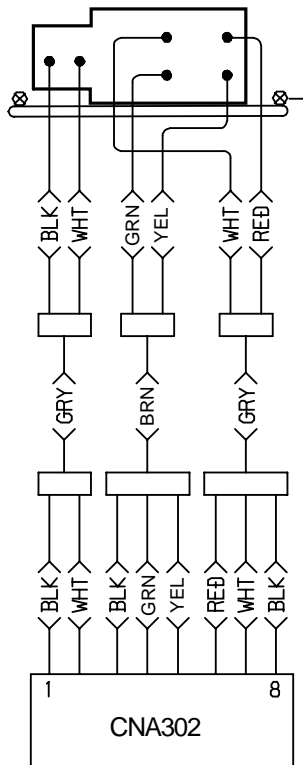
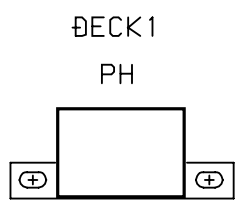
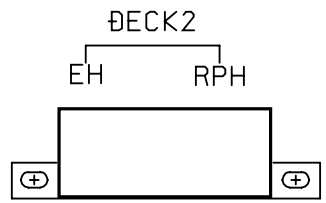
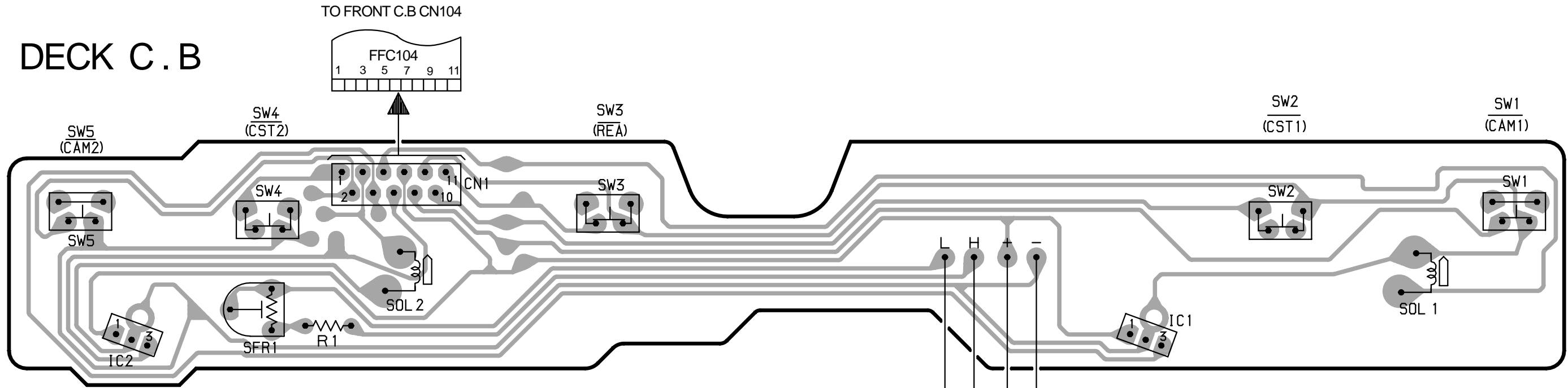

TO CHASSIS GND

A
B
C
D
E
F
G
H
I
J
K
L
M
N
O
P
Q
R
S
T
U

SCHEMATIC DIAGRAM -5/5 (PT SECTION)

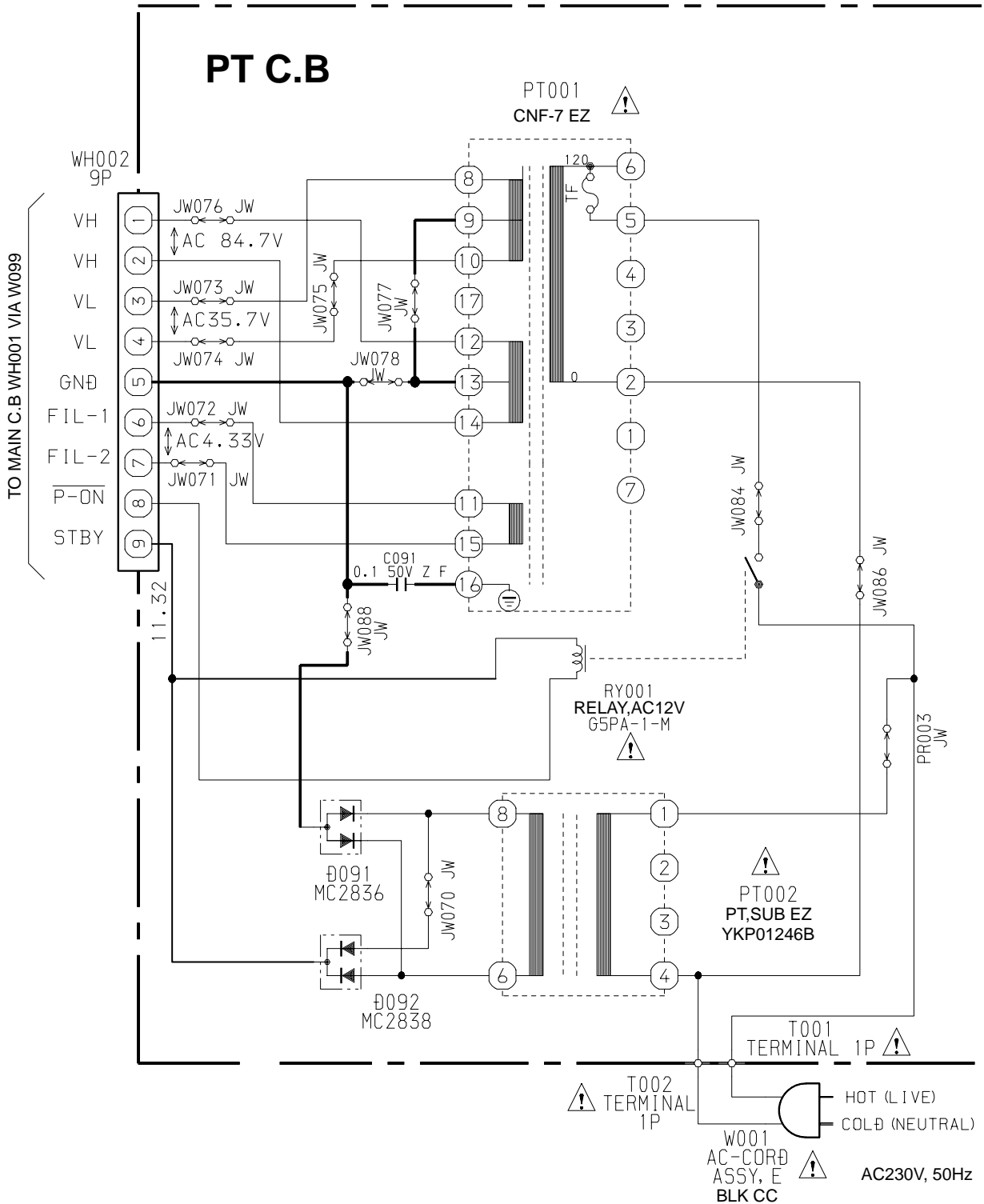

WIRING - 4/4 (PT C.B)

15	14	13	12	11	10	9	8	7	6	5	4	3	2	1
----	----	----	----	----	----	---	---	---	---	---	---	---	---	---

A
B
C
D
E
F
G
H
I
J
K
L
M
N
O
P
Q
R
S
T
U

PT C.B

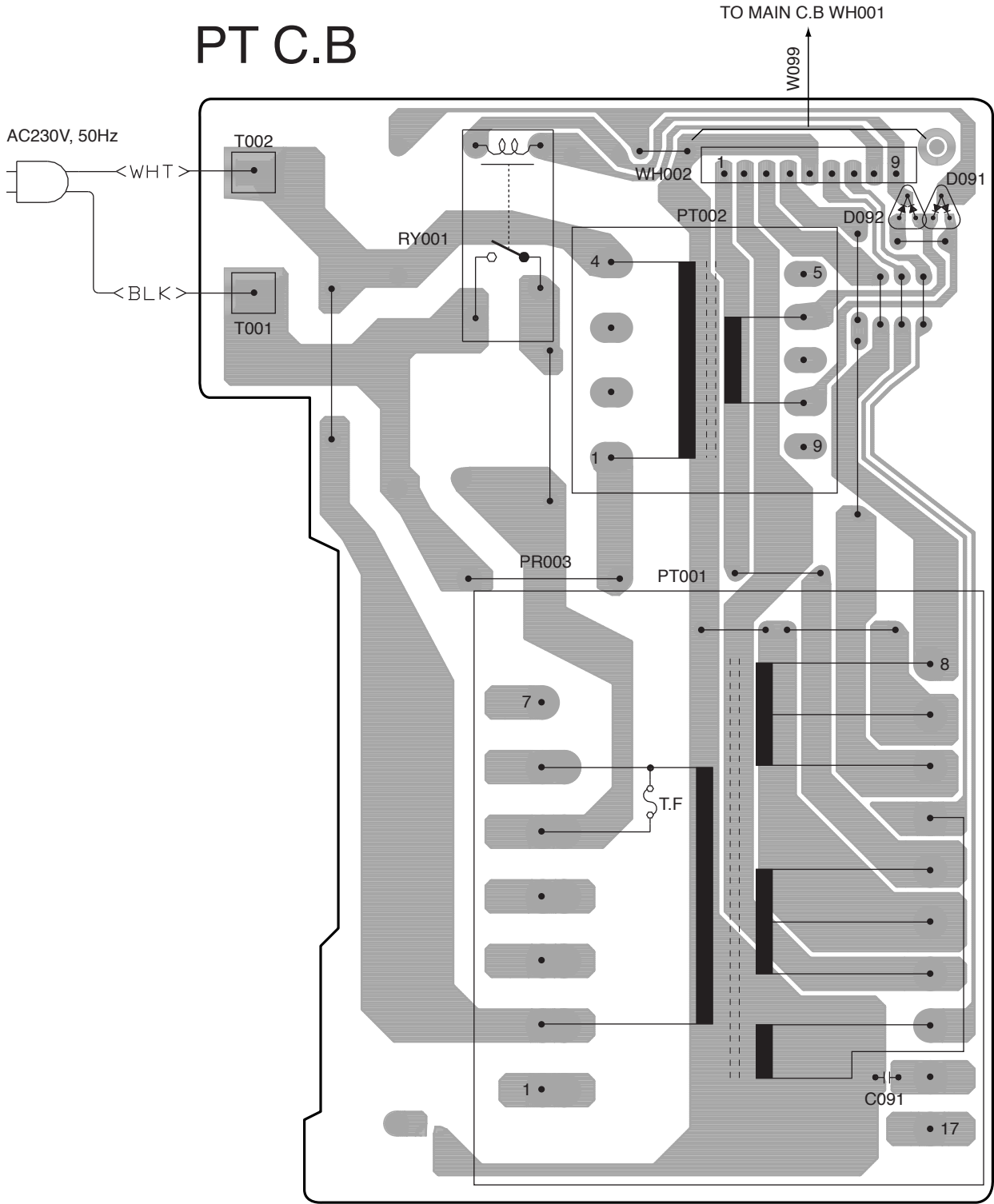

ELECTRICAL ADJUSTMENT -1/7

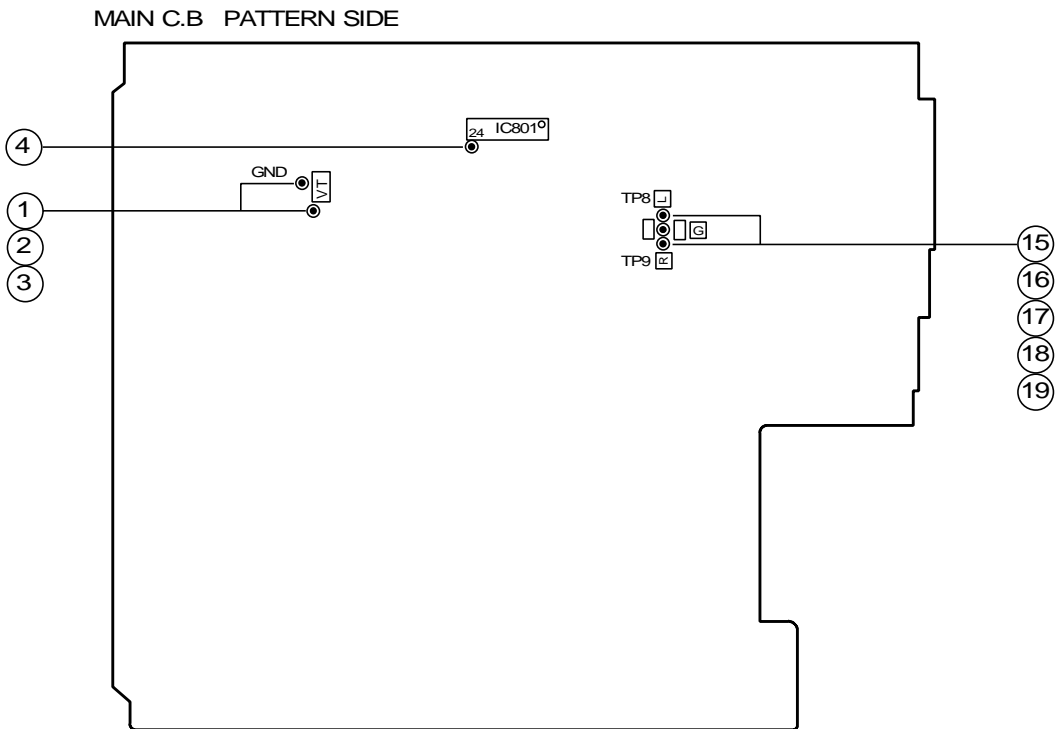
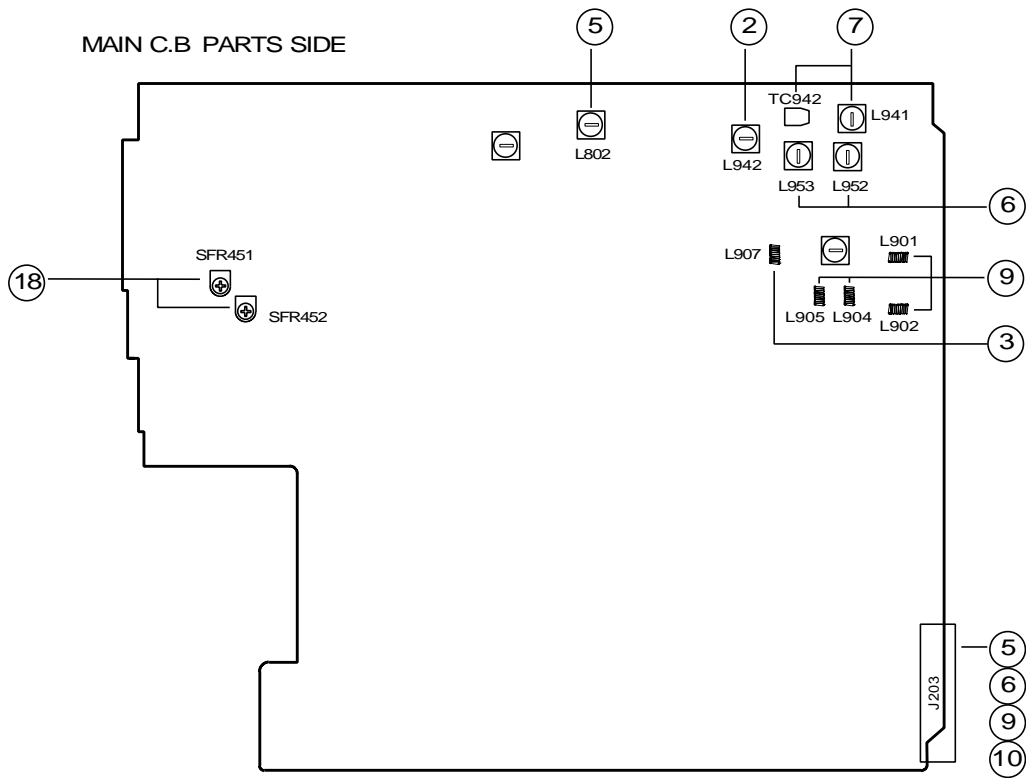

DECK C.B

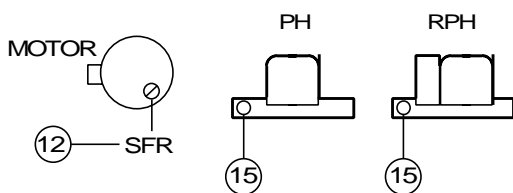

ELECTRICAL ADJUSTMENT -2/7

<TUNER Adjustment>

1. VT Check (MW)

Requirements

- Measuring instrument: Digital multimeter

Test points: VT, GND

- 1) Connect the digital multimeter between VT and GND.
- 2) Set the function to MW, and tune the receiving frequency of the unit at 1,602 kHz.
- 3) Check that the digital multimeter ranges under 8 V.
- 4) Tune the receiving frequency of the unit at 531 kHz.
- 5) Check that the digital multimeter ranges above 0.6 V.

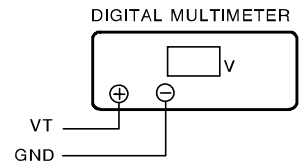

2. VT Adjustment (LW)

Requirements: Same as above.

- Adjustment point: L942

- 1) Connect the digital multimeter between VT and GND.
- 2) Set the function to FM, and tune the receiving frequency of the unit at 144.0 kHz.
- 3) Adjust L942 so that the digital multimeter ranges at 1.3 ± 0.05 V.

3. VT Adjustment and Check (FM)

Requirements: Same as the above.

- Adjustment point: L907

- 1) Connect the digital multimeter between VT and GND.
- 2) Set the function to FM, and tune the receiving frequency of the unit at 108.0 MHz.
- 3) Adjust L907 so that the digital multimeter ranges at 7.0 ± 0.1 V.
- 4) Tune the receiving frequency of the unit at 87.5 MHz.
- 5) Check that the digital multimeter ranges under 0.5 V.

4. CLOCK Check (MW)

Requirements

- Measuring instrument: Frequency counter

Test point: CLOCK (IC801 24PIN), GND

- 1) Connect the frequency counter between CLOCK and GND.
- 2) Set the function to MW, and tune the receiving frequency of the unit at 1,602 kHz.
- 3) Check that the frequency counter ranges at $2,160 \text{ kHz} \pm 45 \text{ Hz}$.

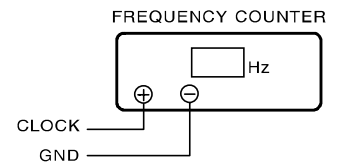

ELECTRICAL ADJUSTMENT -3/7

<MW/LW Adjustment>

Make the following preparations for MW/LW adjustment.

Preparations

- Standard Signal Generator (S.S.G.) / Loop antenna / Oscilloscope / Millivoltmeter / Dummy resistance (6 Ω)
 - 1) Connect the unit and measuring instruments as shown in the diagram below.
 - 2) Position the loop antenna connected to S.S.G. and the one connected to the unit 60 cm apart.

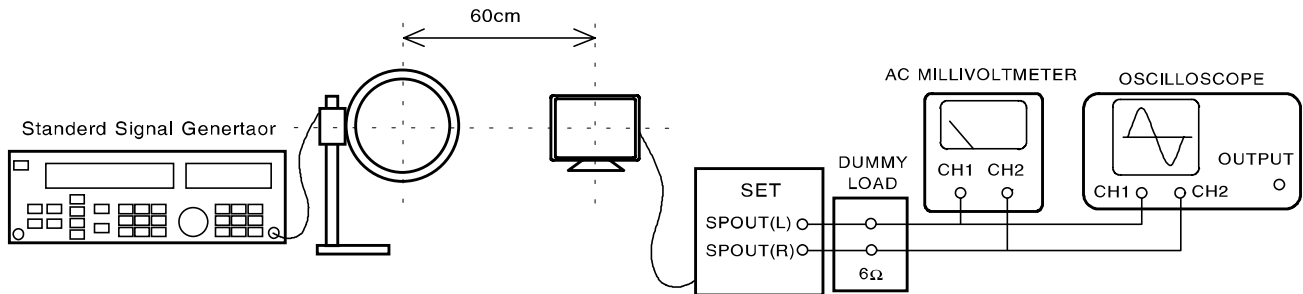

5. IF Adjustment (MW)

Requirements: As instructed in preparations.

- Adjustment point: L802
 - 1) Set S.S.G. to MW; carrier of 999 kHz with 30% modulation, and source at 1 kHz, position output at maximum.
 - 2) Tune the receiving frequency of the unit at MW 999 kHz.
 - 3) While monitoring the waveform at 1 kHz through the oscilloscope, lower the output level of S.S.G. maximum (till a certain degree of noise is monitored).
 - 4) Adjust L802 so that the millivoltmeter points maximum.

6. Tracking Adjustment (MW)

Requirements: As instructed in preparations.

- Adjustment point: L952 / L953
 - 1) Set S.S.G. to MW; carrier of 999 kHz with 30% modulation, and source at 1 kHz, position output at maximum.
 - 2) Tune the receiving frequency of the unit at MW 999 kHz.
 - 3) While monitoring the waveform at 1kHz through the oscilloscope, lower the output level of S.S.G. maximum (till a certain degree of noise is monitored).
 - 4) Adjust L952 so that the millivoltmeter points maximum.
 - 5) Set S.S.G. to MW; carrier of 603 kHz with 30% modulation, and source at 1 kHz.
 - 6) Tune the receiving frequency of the unit at MW 603 kHz.
 - 7) Adjust L953 so that the millivoltmeter points maximum.
 - 8) Repeat above steps 1) to 7) 2 to 3 times.

7. Tracking Adjustment(LW)

Requirements: As instructed in preparations.

- Adjustment point: L941/TC942
 - 1) Set S.S.G. to LW; carrier of 144 kHz with 30% modulation, and source at 1 kHz, position output at maximum.
 - 2) Tune the receiving frequency of the unit at LW 144 kHz.
 - 3) While monitoring the waveform at 1kHz through the oscilloscope, lower the output level of S.S.G. maximum (till a certain degree of noise is monitored).
 - 4) Adjust L941 so that the millivoltmeter points maximum.
 - 5) Set S.S.G. to LW; carrier of 290 kHz with 30% modulation, and source at 1 kHz.
 - 6) Tune the receiving frequency of the unit at LW 290 kHz.
 - 7) Adjust TC942 so that the millivoltmeter points maximum.
 - 8) Repeat above steps 1) to 7) 2 to 3 times.

8. Auto-Stop Check (MW)

Requirements: As instructed in preparations.

- 1) Set S.S.G. to MW; carrier of 999 kHz with 30% modulation, source at 1 kHz, and output of 40 to 70 dBuV.
- 2) Apply the tuning search function, and check that the unit automatically stops at MW 999 kHz.

ELECTRICAL ADJUSTMENT -4/7

<FM Adjustment>

Make the following preparations for FM adjustment.

Preparations

- Standard Signal Generator (S.S.G.) / Loop antenna / Oscilloscope / Millivoltmeter / Dummy resistance (6 Ω)
 - Connect the unit and measuring instruments as shown in the diagram below.
 - Connect the output of S.S.G. to the antenna input of the unit.

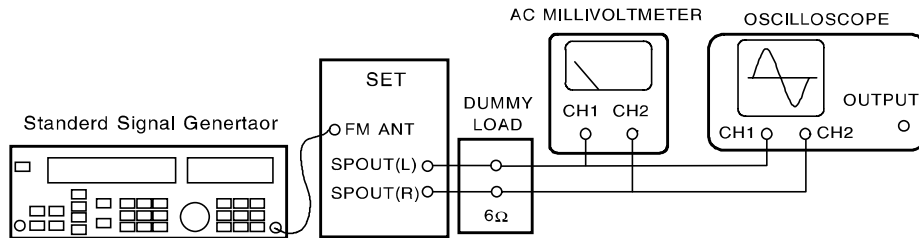

9. Tracking Adjustment

Requirements: As instructed in preparations.

- Adjustment point: L901/L902/L904/L905
 - Set S.S.G. to FM; carrier of 108 MHz with 75 kHz modulation, and source at 1 kHz, position output at maximum.
 - Tune the receiving frequency of the unit at FM 108 MHz.
 - While monitoring the waveform at 1kHz through the oscilloscope, lower the output level of S.S.G. maximum (till a certain degree of noise is monitored).
 - Adjust L905 \rightarrow L904 \rightarrow L902 \rightarrow L901 \rightarrow L902 \rightarrow L904 \rightarrow L905. Repeat adjustment (L905, L904, L902, L901) two to three time so that the millivoltmeter indicates the maximum level.

10. Separation Check

Requirements: As instructed in preparations.

- Set S.S.G. to FM; carrier of 98 MHz with 67.5 kHz modulation, source at 1 kHz, and output at 74 dBuV.
- Switch S.S.G. to PILOT ON, and set PILOT at 7.5 kHz.
- Tune the receiving frequency of the unit at FM 98 MHz.
- Allow the output of S.S.G. only from Lch, and check that the difference between Lch and Rch is 12 dB or above.
- Apply the above check to Rch.

11. Auto-Stop Check

Requirements: As instructed in preparations.

- Set S.S.G. to FM; carrier of 98 MHz with 75 kHz modulation, source at 1kHz, and output at 10 to 35 dBuV or less.
- Apply the tuning search function, and check that the unit automatically stops at FM 98 MHz.

ELECTRICAL ADJUSTMENT -5/7

<DECK Section>

12. Tape Speed Adjustment (DECK 2)

Requirements

- Measuring instrument: Wow and flutter meter (frequency counter)

Test tape: TTA-100 (3 kHz)

Test point: HP OUT

Adjustment point: DECK MOTOR SFR

- Connect the wow and flutter meter to HP OUT of the unit.
- Insert the test tape (TTA-100) to DECK 2. Play back the middle part of the tape, and adjust DECK MOTOR SFR so that the level $3,000 \text{ Hz} \pm 55 \text{ Hz}$ is monitored.

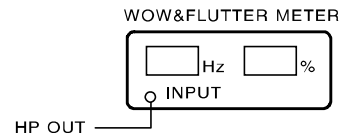

13. Tape Speed Check (DECK 1)

Requirements: Same as the above, 12.

- Insert the test tape (TTA-100) to DECK 1. Play back the middle part of the tape, and check that the level is ranged within $\pm 55 \text{ Hz}$ as compared to the speed monitored for DECK 2.

14. Wow and Flutter Check (DECK 1 and DECK 2)

Requirements: Same as the above, 12.

- Connect the wow and flutter meter to HP OUT of the unit.
- Set the wow and flutter to JIS for INDICATOR and to WRMS (WTD) for mode.
- Play back the middle part of the test tape (TTA-100), and check that the level ranges under 0.25%.

15. Head Azimuth Adjustment (DECK 1 and DECK 2)

Requirements

- Measuring instrument: Oscilloscope

Test tape: TTA-300 (10 kHz)

Test point: TP8 (Lch), TP9 (Rch)

Adjustment point: Head azimuth adjustment screw

- Connect the probe CH1 of the oscilloscope to TP8 (Lch) and CH2 to TP9 (Rch).
- Set V mode of the oscilloscope to ADD.
- Insert the test tape (TTA-300) to DECK 1. Forward and play back the middle part of the tape, and adjust the head azimuth adjustment screw so that the waveform achieves its maximum level when 10 kHz is played.
- After adjustment, secure the screw with glue (1600 B).
- Apply the above steps 3) and 4) to DECK 2.

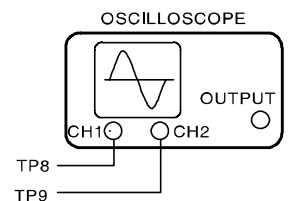

16. Playback Frequency Check (DECK 1 and DECK 2)

Requirements

- Measuring instrument: Millivoltmeter

Test tape: TTA-300 (315 Hz / 10 kHz)

Test point: TP8 (Lch), TP9 (Rch)

- Connect CH1 of the millivoltmeter to TP8 (Lch) and CH2 to TP9 (Rch).
- Insert the test tape (TTA-300) to DECK 1, and play back 315 Hz and 10 kHz.
- Check that the level of 10 kHz is ranged within $\pm 3 \text{ dB}$ compared to the output level of 315 Hz as a reference.
- Apply the above steps 2) and 3) to DECK 2.

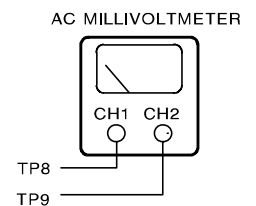

ELECTRICAL ADJUSTMENT -6/7

17. Playback Sensitivity Check (DECK 1 and DECK 2)

Requirements

- Measuring instrument: Millivoltmeter
Test tape: TTA-200 (400 kHz)
Test points: TP8 (Lch), TP9 (Rch)
 - Connect CH1 of the millivoltmeter to TP8 (Lch) and CH2 to TP9 (Rch).
 - Insert the test tape (TTA-200) to DECK 1 and play back.
 - Check that the output level is ranged within $280 \text{ mV} \pm 3 \text{ dB}$.
 - Apply the above steps, 2) and 3) to DECK 2.

18. Record/Playback Frequency Response Adjustment (DECK 2)

Requirements

- Measuring instrument: Millivoltmeter, Audio signal oscillator (low frequency oscillator), Attenuator

Test tape: TTA-602 (NORMAL)

Test points: TP8 (Lch), TP9 (Rch)

Input point: AUX (1 kHz / 8 kHz)

Adjustment points: SFR451 (Lch), SFR452 (Rch)

- Connect CH1 of the millivoltmeter to TP8 (Lch) and CH2 to TP9 (Rch).
- Connect the output of the oscillator to the attenuator, and then the attenuator to AUX of the unit.
- Insert the test tape (TTA-602) to DECK 2, and record 1 kHz signal from AUX.
- Adjust the attenuator so that the output levels at TP8 and TP9 are ranged at 10mV.
- Record 1 kHz and 8 kHz alternatively.
- Play back the tape. Adjust SFR451 (Lch)/SFR452 (Rch) so that the playback output level of 8kHz is ranged within $0 \pm 1 \text{ dB}$ compared to the playback output level of 1 kHz as reference.

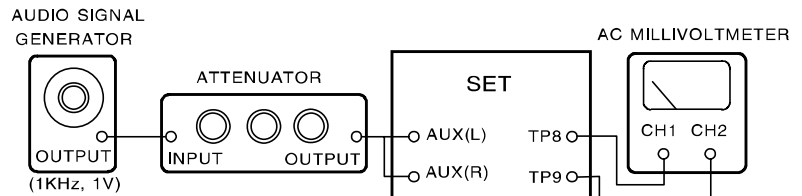

19. Record/Playback Sensitivity Check (DECK 2)

Requirements

- Measuring instrument: Same as the above, 16
Test tape: TTA-602 (NORMAL)
Test point: TP8 (Lch), TP9 (Rch)
Input point: AUX (1 kHz)
 - Insert the test tape (TTA-602) to DECK 2, and record 1 kHz signal from AUX.
 - Adjust the attenuator so that the output levels at TP8 and TP9 are 100 mV.
 - Play back 1kHz, and check that the output level is ranged within $-2 \text{ dB} \pm 2 \text{ dB}$ compared to the recording output level.

ELECTRICAL ADJUSTMENT -7/7

<FRONT Section>

FRONT C.B PATTERN SIDE

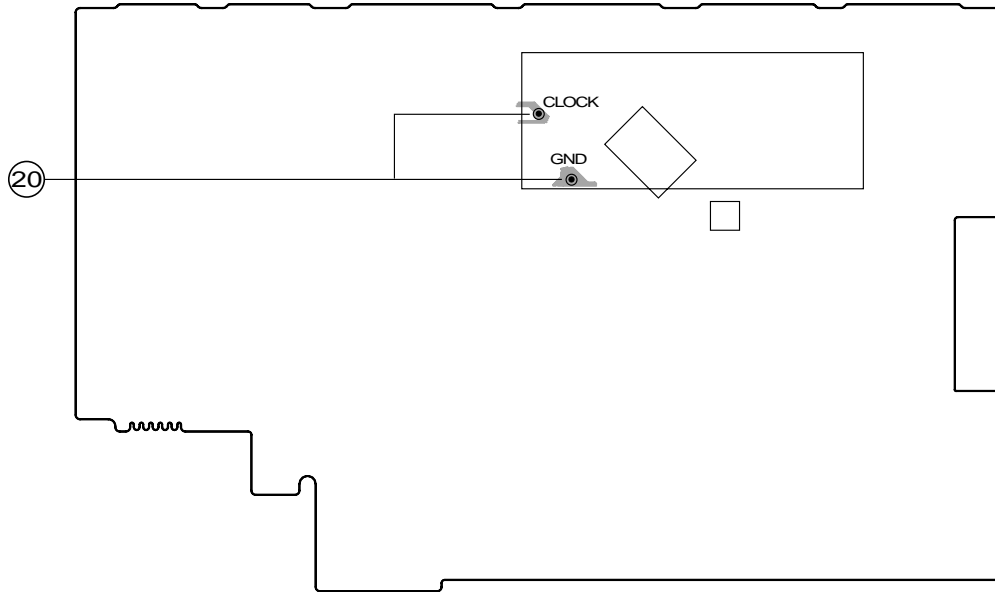

FRONT C.B PARTS SIDE

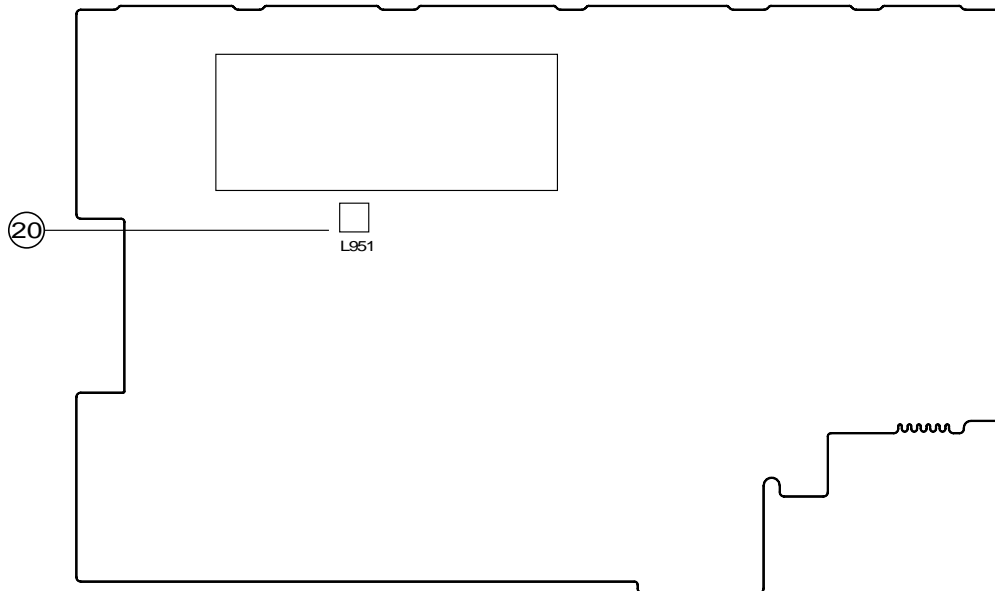

20. Clock Adjustment

Requirements

- Measuring instrument: Frequency counter
- Test point: CLOCK, GND
Adjustment point: L951
- While pressing the UP and POWER button, insert the AC plug to the outlet.
 - Adjust L951 so that the frequency counter indicates the frequency level within 72.743 ± 0.073 Hz.

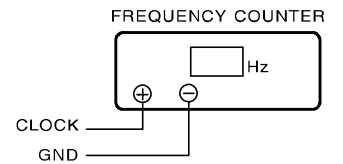

CD TEST MODE -1/1

CD TEST MODE Ver. 3.0

1. Starting CD Test Mode

While pressing and holding down the CD OPEN/CLOSE button, insert the AC plug to outlet.
When test mode starts, the message, TEST appears on the display.

2. Exiting CD Test Mode

Press the other function key, POWER button or remove the AC plug from outlet.

3. Function of CD Test Mode

No	Mode	Function Key	Display	Movement	Check
1	Start Mode		All lit.	FL all lit.	<ul style="list-style-type: none"> • FL check • Microcomputer check
2	Search Mode	STOP button	READING	<ul style="list-style-type: none"> • LD constantly lit. • Focus search continuous movement *1, 2 • Spindle motor continuous kick 	<ul style="list-style-type: none"> • APC circuit check • Laser current electricity measurement • Focus search waveform check • Focus error waveform check (DRF is ignored during search mode.)
3	Play Mode	PLAY button	Normal	<ul style="list-style-type: none"> • Normal playback • If TOC READ is unavailable, focus search is continued. 	<ul style="list-style-type: none"> • Each servo circuit check • DRF check • RF waveform check (1.5 Vp-p Approx.)
4	Traverse Mode	PAUSE button	Normal	<ul style="list-style-type: none"> • Tracking servo OFF/ON OFF and ON is repeated by every press of the PAUSE button. 	<ul style="list-style-type: none"> • Tracking balance check
5	Sled mode	FF button	TEST	<ul style="list-style-type: none"> • PU moves to the innermost position. *3 At the same time, lens is kicked toward inner position. 	<ul style="list-style-type: none"> • Sled circuit check • Tracking circuit check • Mechanism movement check • PU check
		RWD button	TEST	<ul style="list-style-type: none"> • PU moves to the outermost position. *3 At the same time, lens is kicked toward outer position. 	
6	Spindle mode	● REC/ REC MUTE button	All lit.	<ul style="list-style-type: none"> • When the button is pressed at the first time, spindle motor rotates forward (at rough speed). At the second press, rotation is reversed. At the third press, rotation stops. 	<ul style="list-style-type: none"> • Spindle circuit check • Spindle motor check

* 1 When Focus Search operates continuously more than 10 minutes, the protection circuit is activated due to heat generation of the driver IC. In this case, turn off the power, wait for approximately 10 minutes so that heat is released, and then restart.

* 2 When the Focus Search fails three times, the gain is switched for CD-RW at the fourth time.

* 3 Be careful not to damage the gear because the sled motor rotates while the FF or RWD button is being pressed even if the pickup is located in the innermost track or the outermost track.

GRID ASSIGNMENT

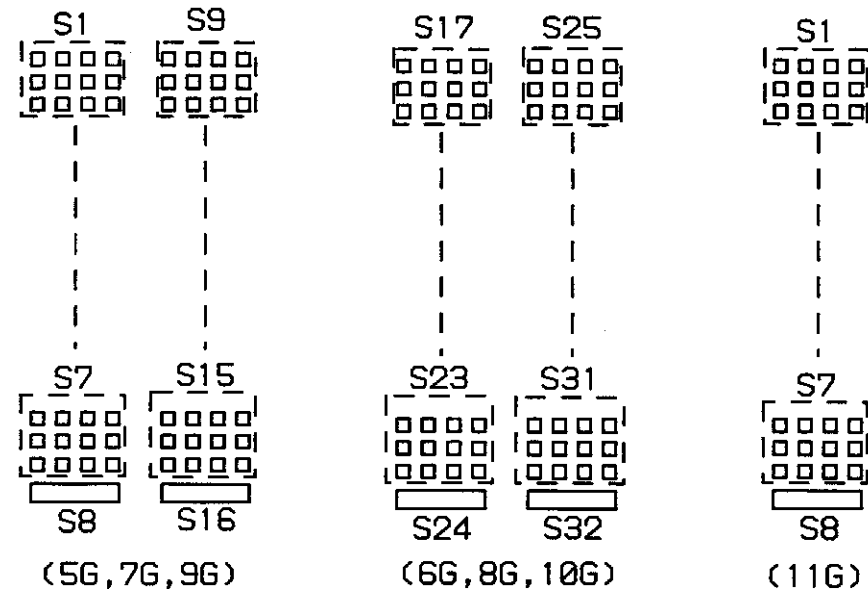
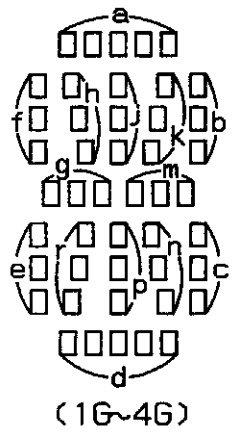
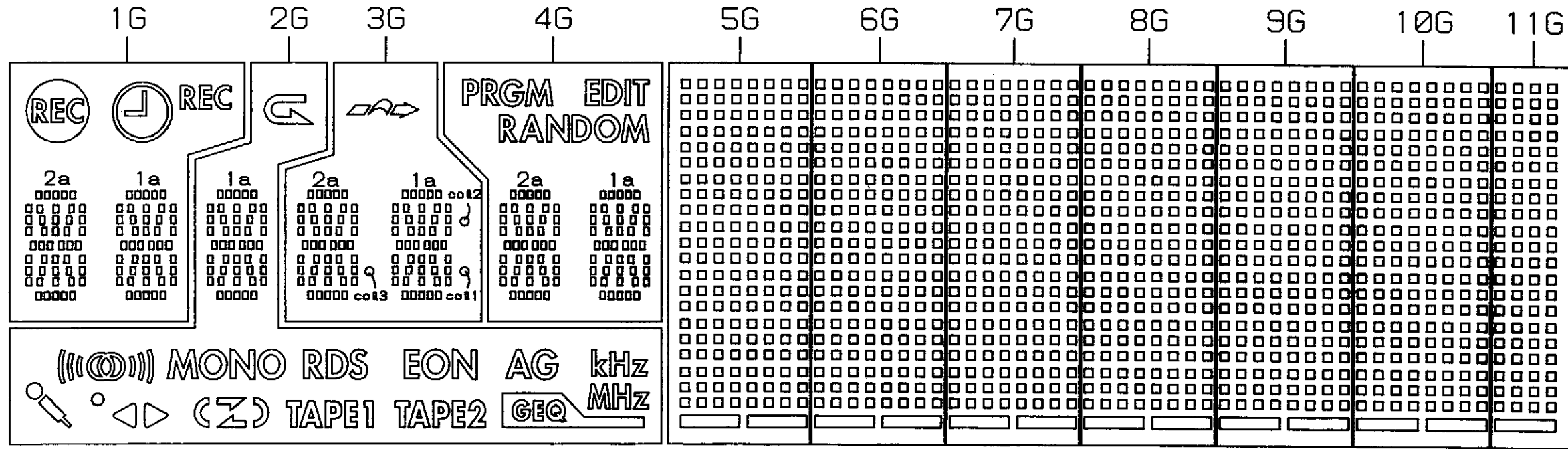

PIN CONNECTION

PIN NO.	5	5	5	5	4	4	4	4	4	4	4	4	4	4	3	3	3	3	3	3	3	3	2	2	2	2	2	2	2	2	2	1	1	1	1	1	1	1	1	1	1	1	1	1	1	1	1	1	1	1		
CONNECTION	F	F	N	N	3	3	3	3	2	2	2	2	2	2	2	2	1	1	1	1	1	1	1	1	1	P	P	P	P	P	P	P	N	N	1	2	3	4	5	6	7	8	9	0	1	N	N	F	F	1	1	1

- NOTE
- 1) F1, F2 --- Filament
 - 2) NP ----- No pin
 - 3) NC ----- No connection
 - 4) 1G~11G -- Grid

	1G	2G	3G	4G	5G	6G	7G	8G	9G	10G	11G
P1	REC			PRGM	S1	-	S1	-	S1	-	S1
P2			col1	EDIT	S9	-	S9	-	S9	-	-
P3			col2	RANDOM	-	S17	-	S17	-	S17	-
P4	-		col3	-	-	S25	-	S25	-	S25	-
P5	2a		2a	2a	S2	-	S2	-	S2	-	S2
P6	2h		2h	2h	S10	-	S10	-	S10	-	-
P7	2j	MONO	2j	2j	-	S18	-	S18	-	S18	-
P8	2k		2k	2k	-	S26	-	S26	-	S26	-
P9	2b		2b	2b	S3	-	S3	-	S3	-	S3
P10	2f		2f	2f	S11	-	S11	-	S11	-	-
P11	2m	TAPE1	2m	2m	-	S19	-	S19	-	S19	-
P12	2g	TAPE2	2g	2g	-	S27	-	S27	-	S27	-
P13	2c	RDS	2c	2c	S4	-	S4	-	S4	-	S4
P14	2e	EON	2e	2e	S12	-	S12	-	S12	-	-
P15	2r		2r	2r	-	S20	-	S20	-	S20	-
P16	2p	AG	2p	2p	ANODE CONNECTION	-	S28	-	S28	-	-
P17	2n	MHz	2n	2n	S5	-	S5	-	S5	-	S5
P18	2d	KHz	2d	2d	S13	-	S13	-	S13	-	-
P19	1a	1a	1a	1a	-	S21	-	S21	-	S21	-
P20	1h	1h	1h	1h	-	S29	-	S29	-	S29	-
P21	1j	1j	1j	1j	S6	-	S6	-	S6	-	S6
P22	1k	1k	1k	1k	S14	-	S14	-	S14	-	-
P23	1b	1b	1b	1b	-	S22	-	S22	-	S22	-
P24	1f	1f	1f	1f	-	S30	-	S30	-	S30	-
P25	1m	1m	1m	1m	S7	-	S7	-	S7	-	S7
P26	1g	1g	1g	1g	S15	-	S15	-	S15	-	-
P27	1c	1c	1c	1c	-	S23	-	S23	-	S23	-
P28	1e	1e	1e	1e	-	S31	-	S31	-	S31	-
P29	1r	1r	1r	1r	S8	-	S8	-	S8	-	S8
P30	1p	1p	1p	1p	S16	-	S16	-	S16	-	-
P31	1n	1n	1n	1n	-	S24	-	S24	-	S24	-
P32	1d	1d	1d	1d	-	S32	-	S32	-	S32	-

IC BLOCK DIAGRAM -1/2

IC, BD3881FV

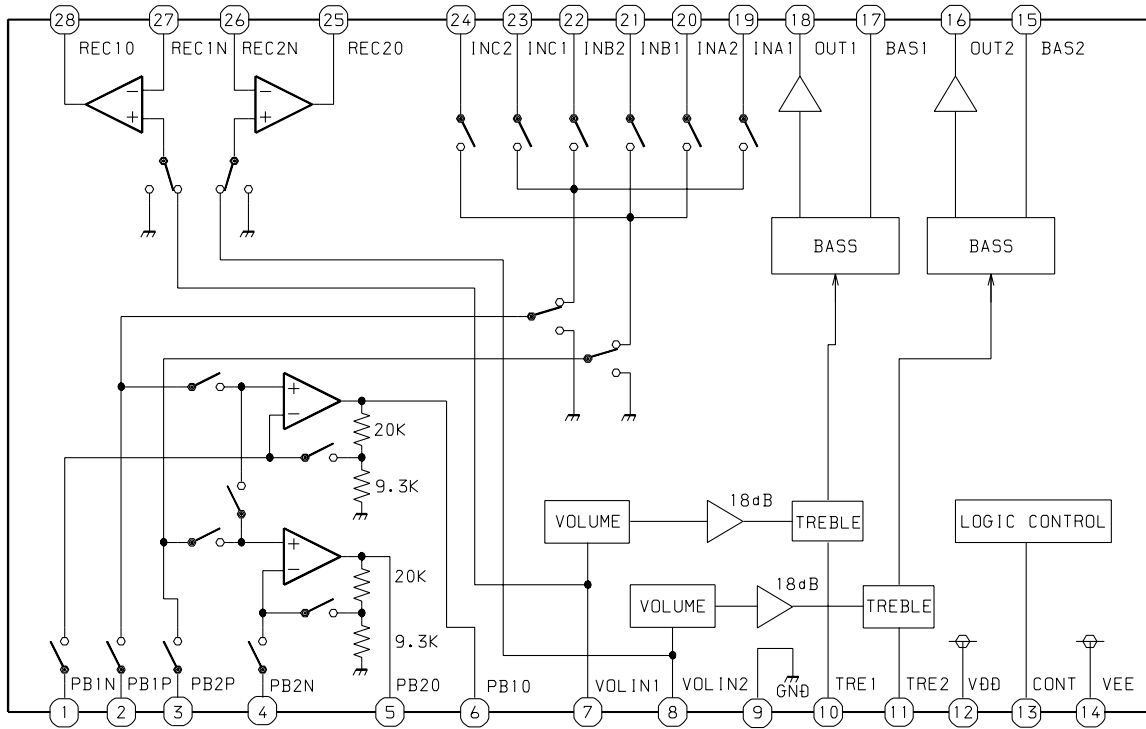

IC, BU1920FS

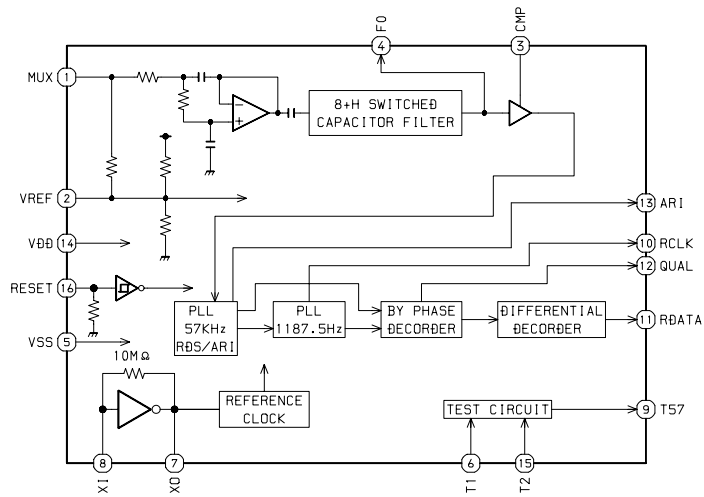

IC BLOCK DIAGRAM -2/2

IC, LA1845N-A

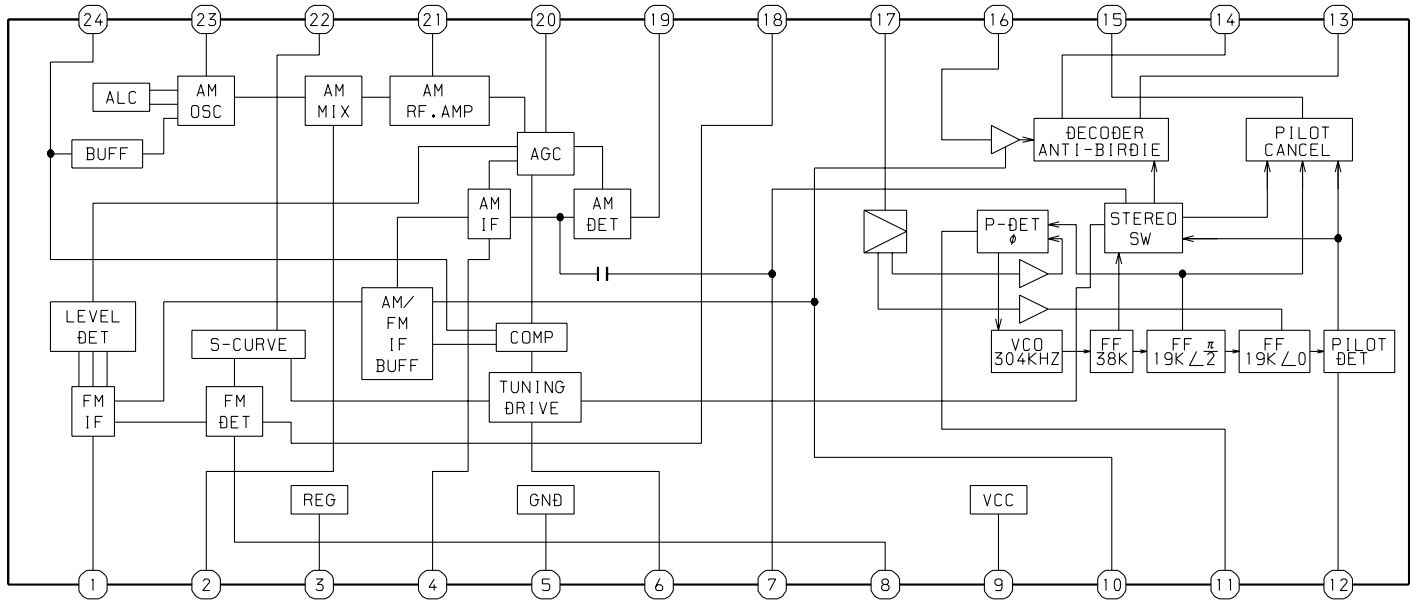

IC, LC7213D-N

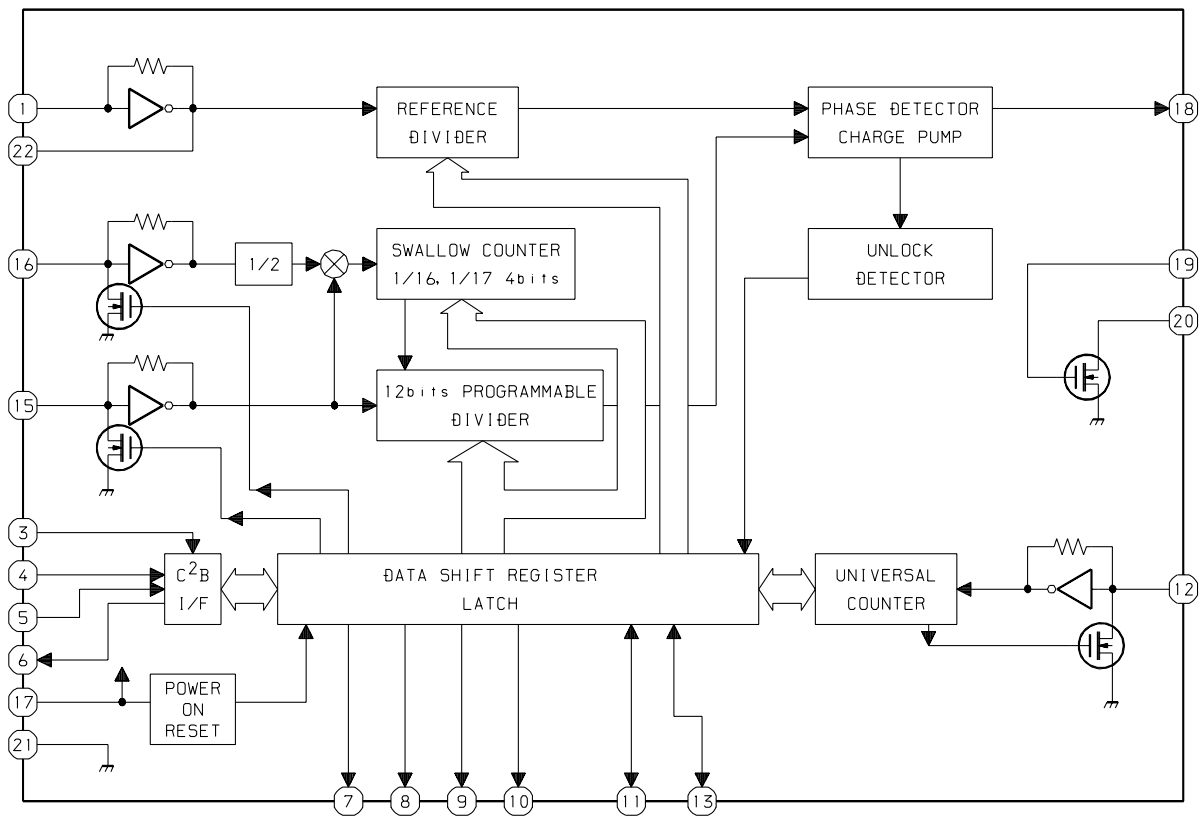

IC DESCRIPTION -1/1(μ PD780228GF-087-3BA)-1/2

Pin No.	Pin Name	I/O	Description
1	O-MOTOR	O	DECK motor output.
2	O-SOL1	O	DECK1 solenoid output.
3	O-SOL2	O	DECK2 solenoid output.
4	O-STBY LED	O	Standby LED output.
5	O-MUTE	O	System mute ON/OFF output.
6	O-KSCAN	O	Key scan timing output.
7	O-PLL_CE	O	PLL chip enable output for LC72131D-N.
8	I-TM_BASE	I	Time-base signal input.
9	O-TU-ON	O	Tuner ON/OFF output.
10	O-PB2	O	DECK2 play back ON/OFF output.
11	O-VF	ñ	Not used.
12	I-AUTO1	I	DECK1 detecting reel rotation switch input.
13	I-REA	I	DECK2 prevention for mistaken recording switch input.
14	I-CST1	I	DECK1 cassette detect switch input.
15	I-CST2	I	DECK2 cassette detect switch input.
16	I-AUTO2	I	DECK2 detecting reel rotation switch input.
17	IC	ñ	GND.
18	VSS0	ñ	GND.
19	VDD0	ñ	Power supply input.
20	O-POWER	O	System power supply ON/OFF output.
21	I-JOG_A	I	JOG rotary encoder signal input (A/D).
22	I-JOG_B	I	JOG rotary encoder signal input (A/D).
23	I-VOL_A	I	VOL rotary encoder signal input (A/D).
24	I-VOL_B	I	VOL rotary encoder signal input (A/D).
25	I-SUBQ	I	CD SUBQ serial input.
26	I-WRQ	I	CD IC control input.
27	I-DRF	I	CD IC control input.
28	I-RDS_CLK	I	Tuner RDS clock output for BU1920FS. (Connected to GND through a resistor)
29	I-RDS_DATA	I	Tuner RDS data output for BU1920FS. (Connected to GND through a resistor)
30	RESET	I	Reset input.
31	O-DSC/O-DATA	O	Serial data latch output for BD3881FV / PLL data output for LC72131D-N.
32	O-CLK_SFT	O	MICON clock shift output.
33	I-IFC	I	Tune IF count serial data input.
34	I-RMC	I	System remote control signal input.
35	I-DISH	I	CD turntable photo sensor signal input.
36	I-STEREO	I	Tuner stereo detected input.
37	VDD1	ñ	Power supply input.
38	X2	ñ	4.19MHz oscillator circuit.
39	X1	ñ	4.19MHz oscillator circuit.
40	VSS	ñ	GND.
41	AVDD	ñ	Power supply input.
42	I-HOLD	I	Power failure detected input "L" to stop clock and hold memory.
43	I-CDSW	I	CD mechanical switch A/D converter input.

IC DESCRIPTION -1/1(μ PD780228GF-087-3BA)-2/2

Pin No.	PinName	I/O	Description
44	I-SPEANA_1	I	A/D input for spectrum analyser level display.
45	I-SPEANA_2	I	A/D input for spectrum analyser level display.
46	I-SPEANA_3	I	A/D input for spectrum analyser level display.
47	I-KEY 1	I	Key A/D input 1.
48	I-KEY 2	I	Key A/D input 2.
49	I-TU_SIG	I	Tuner RDS signal input. (Connected to GND through a resistor)
50	AVSS	\bar{n}	GND.
51	O-BIAS	O	Bias output.
52	O-CD_CE	O	CD chip enable output.
53	O-CD_CLK	O	CD serial clock output.
54	O-CD_DATA	O	CD serial data output.
55	O-CLK	O	PLL clock output for LC72131D-N.
56 ~ 59	NC	\bar{n}	Not connected.
60	I-CAM2	I	DECK2 cam switch input.
61	I-CAM1	I	DECK1 cam switch input.
62 ~ 70	P24 ~ P16	O	FL segment P24 ~ P16 output.
71	P15/AM 10K	O/I	FL segment P15 output / AM 10K data input to diode.
72	P14/KARAOKE	O/I	FL segment P14 output / KARAOKE data input to diode (LH only).
73	P13/LW	O/I	FL segment P13 output / LW data input to diode (not used).
74	P12/SW	O/I	FL segment P12 output / SW data input to diode (not used).
75	P11/OIRT	O/I	FL segment P11 output / OIRT data input to diode (not used).
76	P10/FM WIDE	O/I	FL segment P10 output / FM WIDE data input to diode (not used).
77	P9/R+1	O/I	FL segment P9 output / R+1 data input to diode (not used).
78	P8/DEMO	O/I	FL segment P8 output / DEMO data input to diode (not used).
79	VDD2	\bar{n}	Power supply input.
80	VLOAD	-	Power supply for FL display.
81	P7/ECO-OFF	O/I	FL segment P7 output / ECO-OFF data input to diode (not used).
82 ~ 87	P6 ~ P1	O	FL segment P6 ~ P1 output.
88 ~ 100	G1 ~ G13	O	FL grid G1 ~ G13 output.

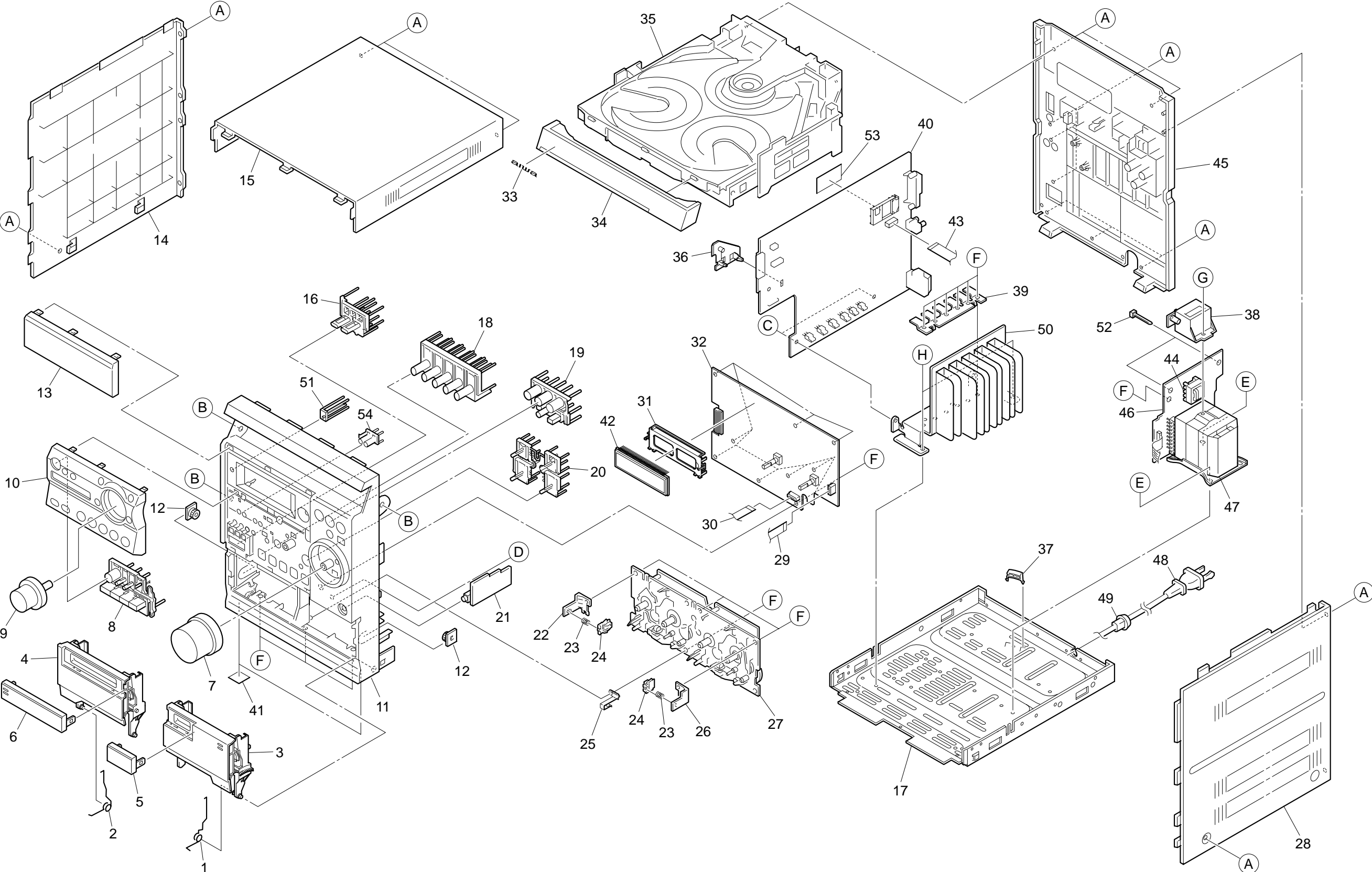

MECHANICAL MAIN PARTS LIST -1/1

! = SAFETY PARTS
 C = Components marked

All components used on this model at the production line are shown in this service manual.
 However, please note that not all components will be available as spare parts for after-sales service.
 Components marked S and O are designated as spare parts for service and will be stocked at the spare parts centers.
 Components marked X and R are not designated as spare parts for after sales service, and will not be stocked at the spare parts centers.

UNIT-NAME	! C	REF-NO	PARTS-NO	PARTS-NAME	SUFFIX&MODEL	
					CX-SNR41 EZSC	
	O	MC1001	8A-NF8-282-010	SPR-T,EJECT 2	a	
	O	MC1002	8A-NF8-281-010	SPR-T,EJECT 1	a	
	O	MC1003	8C-NF8-003-010	BOX,CASS 2	a	
	O	MC1004	8C-NF8-002-010	BOX,CASS 1	a	
	O	MC1005	8C-NF8-006-010	WINDOW,CASS 2	a	
	O	MC1006	8C-NF8-005-010	WINDOW,CASS 1	a	
	O	MC1007	8C-NF8-020-010	KNOB,RTRY VOL	a	
	X	MC1008	8C-NF8-009-010	KEY,POWER	a	
	X	MC1009	8C-NF8-027-010	KNOB,RTRY JOG	a	
	X	MC1010	8C-NF7-031-010	PANEL,FR EZR	a	
	O	MC1011	8C-NF7-005-010	CABI,FR EZR	a	
	O	MC1012	8Z-NF6-210-010	DMPR,150 N	a	
	O	MC1013	8C-NF7-010-010	WINDOW,DISP EZ	a	
	O	MC1014	8C-NF8-021-010	PANEL,LEFT	a	
	O	MC1015	8C-NF8-023-110	PANEL, TOP	a	
	O	MC1016	8C-NF8-029-010	KEY,REC EZ	a	
	X	MC1017	8C-NF8-232-010	CHAS,MAIN CC 66-70	a	
	X	MC1018	8C-NF8-013-010	KEY, OPE	a	
	O	MC1019	8C-NF7-006-010	KEY,ASSY CD	a	
	X	MC1019a	8C-NF7-001-010	KEY,CD LED	a	
					CX-SNR41 EZSC	
	X	MC1019b	8C-NF7-002-010	REFLECTOR,CD	a	
	X	MC1020	8C-NF8-011-010	KEY,ENTER	a	
	X	MC1021	8C-NF8-646-010	PWB,HP EZ/K/HS	a	
	O	MC1022	87-NF4-216-010	HLDR,LOCK 1	a	
	X	MC1023	86-NF9-224-010	SPR-C,LOCK	a	
	O	MC1024	82-NF5-229-010	PLATE,LOCK(*)	a	
	X	MC1025	8A-NF8-217-010	PLATE,EARTH MECHA C	a	
	O	MC1026	87-NF4-217-110	HLDR,LOCK 2	a	
	X	MC1027	M8-ZZM-39F-070	ZZM-3 YPR4NC	a	
	O	MC1028	8C-NF8-052-010	PANEL,RIGHT 1V	a	
	O	MC1029	88-908-301-110	FF-CABLE,8P 1.25 300MM	a	
	O	MC1030	88-911-101-110	FF-CABLE,11P 1.25 100MM	a	
	O	MC1031	8B-NF9-207-010	GUIDE,FL 90.2-20	a	
	X	MC1032	8C-NF7-641-010	PWB,FRONT	a	
	O	MC1033	87-B00-002-010	BADGE,AIWA 30 ABS SIL	a	
	X	MC1034	8C-NF8-008-010	PANEL,TRAY	a	
	X	MC1035	M8-BZG-29G-170	BZG-2 ZD5GNC	a	
	O	MC1036	8A-NF8-206-010	HLDR,PWB M	a	
	O	MC1037	87-NF4-221-010	HLDR,CABLE	a	
	O	MC1038	8A-NF9-211-010	HLDR,PWB PT HI	a	
					CX-SNR41 EZSC	
	X	MC1039	8C-NF8-202-110	HLDR,TR	a	
	X	MC1040	8C-NF8-641-010	PWB,MAIN EZ/K/HS	a	
	X	MC1041	8B-NF9-204-010	CUSH, 11-8.5-2	a	
	O	MC1042	8B-NF1-610-010	FL,BJ854GNK BNF-1	a	
	O	MC1043	88-906-251-110	FF-CABLE,6P 1.25	a	
	!	O	MC1044	8C-NF8-655-010	PT,SUB EZ YKP01246B	a
	O	MC1045	8C-NF7-024-010	CABI,REAR EZSC	a	
	X	MC1046	8C-NF8-642-010	PWB,PT 66 EZ/K/HS	a	
	!	O	MC1047	8C-NF7-608-010	PT,CNF-7 EZ	a
	!	X	MC1048	87-A80-157-010	AC CORD ASSY,E BLK CC	a
	O	MC1049	87-085-185-010	BUSHING,AC CORD(E) CM-22B	a	
	X	MC1050	8C-NF7-209-010	HT-SINK,ASSYC 3	a	
	X	MC1050a	8C-NF7-207-010	HT-SINK,MAINC	a	
	X	MC1050b	8C-NF8-213-010	HT-SINK,FIN C	a	
	O	MC1051	8C-NF8-014-010	REFLECTOR,ECO	a	
	O	MC1052	87-A90-193-010	HLDR,CV100 (B)	a	
	X	MC1053	8C-ZA3-618-010	SHLD-CASE,CZA-3 EZ S	a	
	X	MC1054	8C-NF7-009-010	KEY,RDS W/O AG	a	
	O	MC1A	87-B10-091-010	UTT2+3-10 W/O SLOT BLK	a	
	O	MC1B	87-721-096-410	QT2+3-10 W/O SLOT	a	
					CX-SNR41 EZSC	
	O	MC1C	87-NF4-224-010	S-SCREW,IT3B+3-8 CU	a	
	O	MC1D	88-AR1-217-010	S-SCREW,BFT2+3-8	a	
	O	MC1E	87-078-200-010	S-SCREW,ITC+4-8 R	a	
	O	MC1F	87-067-703-010	BVT2+3-10 W/O SLOT	a	
	O	MC1G	87-067-689-010	BVTT+3-8	a	
	O	MC1H	87-B10-315-010	BVIT3B+3-8 R W/O	a	

COLOR NAME TABLE -1/1

Basic color symbol	Color	Basic color symbol	Color	Basic color symbol	Color
B	Black	C	Cream	D	Orange
G	Green	H	Gray	L	Blue
LT	Transparent Blue	N	Gold	P	Pink
R	Red	S	Silver	ST	Titan Silver
T	Brown	V	Violet	W	White
WT	Transparent White	Y	Yellow	YT	Transparent Yellow
LM	Metallic Blue	LL	Light Blue	GT	Transparent Green
LD	Dark Blue	DT	Transparent Orange	GM	Metallic Green
YM	Metallic Yellow	DM	Metallic Orange	PT	Transparent Pink
LA	Aqua Blue	GL	Light Green	HT	Transparent Gray
HM	Metallic Gray	NH	Champagne Gold	M	Wood Pattern

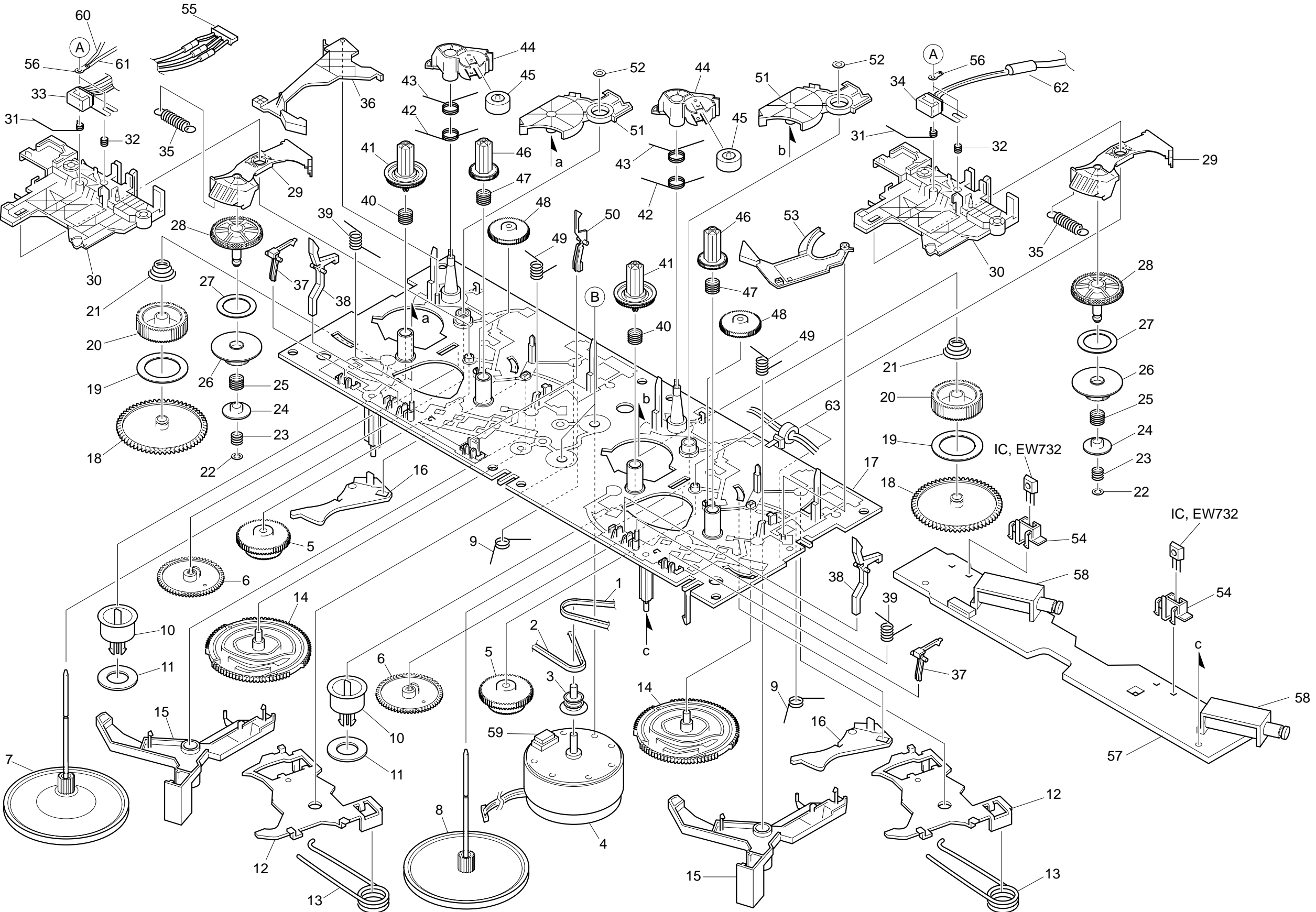

TAPE MECHANISM PARTS LIST <ZM-3 YPR4NC> -1/2

! = SAFETY PARTS
 C = Components marked

All components used on this model at the production line are shown in this service manual.

However, please note that not all components will be available as spare parts for after-sales service.

Components marked S and O are designated as spare parts for service and will be stocked at the spare parts centers.

Components marked X and R are not designated as spare parts for after sales service, and will not be stocked at the spare parts centers.

UNIT-NAME	! C	REF-NO	PARTS-NO	PARTS-NAME	SUFFIX&MODEL
					ZZM-3 YPR4NC
	O	ST1001	8Z-ZM3-227-210	BELT,MAIN M3	a
	O	ST1002	8Z-ZM3-235-110	BELT,MAIN L	a
	O	ST1003	8Z-ZM1-235-010	PULLEY,MOT	a
	O	ST1004	87-A92-321-010	MOT,SHU2L 60	a
	O	ST1005	8Z-ZM1-232-010	GEAR,IDL FF/REW	a
	O	ST1006	8Z-ZM3-229-010	GEAR,IDL M3	a
	O	ST1007	8Z-ZM3-256-010	FLY-WHL ASSY,M3 R	a
	X	ST1007a	8Z-ZM2-211-310	FLY-WHL,ZZM-2	a
	X	ST1007b	8Z-ZM3-242-110	SHAFT,CAP M3	a
	O	ST1008	8Z-ZM3-255-010	FLY-WHL ASSY,M3 L	a
	X	ST1008a	8Z-ZM3-228-210	FLY-WHL,M3	a
	X	ST1008b	8Z-ZM3-242-110	SHAFT,CAP M3	a
	O	ST1009	8Z-ZM3-231-310	SPR-T,TRIG	a
	O	ST1010	8Z-ZM3-213-110	CLR,MG	a
	O	ST1011	82-ZM3-616-010	RING MAGNET 4	a
	O	ST1012	8Z-ZM3-243-110	LEVER ASSY,HD UP	a
	X	ST1012a	8Z-ZM3-207-010	LEVER,HD UP	a
	X	ST1012b	8Z-ZM3-241-110	SHAFT,HD UP	a
	O	ST1013	8Z-ZM3-238-110	SPR-T,HD UP	a
	O	ST1014	8Z-ZM3-219-310	GEAR,CAM M3	a
					ZZM-3 YPR4NC
	O	ST1015	8Z-ZM3-206-010	LEVER,TRIG	a
	O	ST1016	8Z-ZM3-209-010	LEVER,CAM FR	a
	O	ST1017	8Z-ZM3-203-310	CHAS ASSY,M3	a
	X	ST1017a	8Z-ZM1-268-010	BRG,METAL	a
	X	ST1017b	8Z-ZM3-201-310	CHAS ASSY,OUT-SERT M3	a
	X	ST1017c	8Z-ZM3-202-010	CHAS,M3	a
	O	ST1018	8Z-ZM1-228-010	GEAR,SLIP T-UP B	a
	O	ST1019	8Z-ZM1-265-010	FELT,T-UP	a
	O	ST1020	8Z-ZM1-227-010	GEAR,SLIP T-UP A	a
	O	ST1021	8Z-ZM1-251-310	SPR-C,T-UP SLIP	a
	O	ST1022	8Z-ZM1-275-010	W-L,1.47-4-0.25	a
	O	ST1023	8Z-ZM1-257-210	SPR-C,F/R	a
	O	ST1024	8Z-ZM1-236-010	CLR,SLIP FF/REW	a
	O	ST1025	8Z-ZM3-261-010	SPR-C,FR M3 C	a
	O	ST1026	8Z-ZM3-250-010	GEAR,SLIP F/R A M3	a
	O	ST1027	8Z-ZM1-269-010	FELT,FF/REW 2	a
	O	ST1028	8Z-ZM1-238-110	GEAR,SLIP FF/REW B 2	a
	O	ST1029	8Z-ZM3-220-110	LEVER,FR M3	a
	O	ST1030	8Z-ZM3-205-110	LEVER,PLAY M3	a
	O	ST1031	8Z-ZM3-262-010	SPR-T,BRG M3 C	a
					ZZM-3 YPR4NC
	O	ST1032	84-ZM2-227-310	SPR-C,AZIMUTH	a
	O	ST1033	87-A92-324-010	HEAD,RPEH C-9142-CD	a
	O	ST1034	87-A92-325-010	HEAD,PH P-9142-CD	a
	O	ST1035	8Z-ZM3-263-010	SPR-E,FR C	a
	O	ST1036	8Z-ZM3-211-110	LEVER,EJECT R	a
	O	ST1037	8Z-ZM3-225-110	LEVER,STOP	a
	O	ST1038	8Z-ZM3-221-210	LEVER,CAS	a
	O	ST1039	8Z-ZM3-234-310	SPR-T,LVR CAS	a
	O	ST1040	8Z-ZM3-223-310	SPR-C,REEL R M3	a
	O	ST1041	8Z-ZM1-225-110	GEAR,REEL R	a
	O	ST1042	8Z-ZM3-264-010	SPR-T,T-UP M3 C	a
	O	ST1043	8Z-ZM3-252-010	SPR-T,PINCH 2	a
	O	ST1044	8Z-ZM3-215-110	LEVER,PINCH M3	a
	O	ST1045	8Z-ZM1-261-110	ROLLER ASSY,PINCH	a
	X	ST1045a	8Z-ZM1-263-010	ROLLER,PINCH	a
	X	ST1045b	8Z-ZM1-262-010	CLR,ROLLER	a
	O	ST1046	8Z-ZM1-226-010	GEAR,REEL L	a
	O	ST1047	8Z-ZM3-222-210	SPR-C,REEL L M3	a
	O	ST1048	8Z-ZM3-251-010	GEAR,IDL REW M3	a
	O	ST1049	8Z-ZM3-236-310	SPR-T,PLAY M3	a
					ZZM-3 YPR4NC
	O	ST1050	82-ZM1-240-110	LVR,REC	a
	O	ST1051	8Z-ZM3-216-310	LEVER,T-UP M3	a
	O	ST1052	87-B10-301-010	W-L,1.63-3.2-0.5 SLIT	a
	O	ST1053	8Z-ZM3-212-010	LEVER,EJECT L	a
	O	ST1054	8Z-ZM3-214-010	HLDR,IC	a
	O	ST1055	86-ZM3-605-110	CONN ASSY,8P -RPB	a
	X	ST1056	87-450-411-010	TERMINAL,LB 1	a
	X	ST1057	8Z-ZM3-604-010	PWB,MAIN C	a
	O	ST1058	82-ZM3-621-210	SOL ASSY,27 KO	a
	X	ST1058a	82-ZM3-622-010	HLDR,BOBBIN SOL KO	a
	X	ST1058b	82-ZM3-623-010	YOKE,SOL KO	a
	X	ST1058c	82-ZM3-624-010	SHAFT,CORE SOL KO	a
	X	ST1058d	82-ZM3-625-010	SHAFT,PLUNGER SOL KO	a
	X	ST1058e	82-ZM3-626-010	TERMINAL,SOL KO	a
	X	ST1059	8Z-ZM3-224-210	SH,BELT M3	a
	X	ST1060	89-936-100-110	WIRE,UB6-10-3	a
	X	ST1061	89-937-220-110	WIRE,UB7-22-3	a
	O	ST1062	86-ZM3-604-210	CONN ASSY,3P -PB	a
	O	ST1063	87-A90-193-010	HLDR,CV100 (B)	a
	O	ST1A	84-ZM2-252-010	S-SCREW,AZI-2-6.4 C	a

TAPE MECHANISM PARTS LIST <ZZM-3 YPR4NC> -2/2

! =  SAFETY PARTS

C = Components marked

All components used on this model at the production line are shown in this service manual.

However, please note that not all components will be available as spare parts for after-sales service.

Components marked S and O are designated as spare parts for service and will be stocked at the spare parts centers.

Components marked X and R are not designated as spare parts for after sales service, and will not be stocked at the spare parts centers.

UNIT-NAME	! C	REF-NO	PARTS-NO	PARTS-NAME	SUFFIX&MODEL
					ZZM-3
					YPR4NC
	O	ST1B	8Z-ZM3-245-110	V+2.6 ZZM-3	a

GENERAL SPEAKER DISASSEMBLY INSTRUCTIONS (FOR REFERENCE) -1/1

Type.1

Insert a flat-bladed screwdriver into the position indicated by the arrows and remove the panel. Remove the screws of each speaker unit and then remove the speaker units.

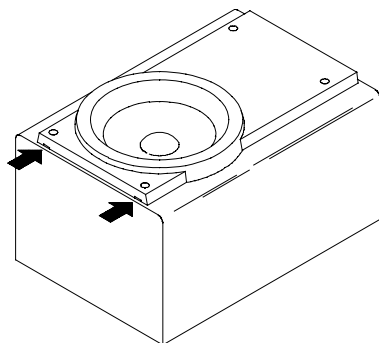

Type.2

Remove the grill frame and four pieces of rubber caps by pulling out with a flat-bladed screwdriver. Remove the screws from hole where installed rubber caps. Insert a flat-bladed screwdriver into the position indicated by the arrows and remove the panel. Remove the screws of each speaker unit and then remove the speaker units.

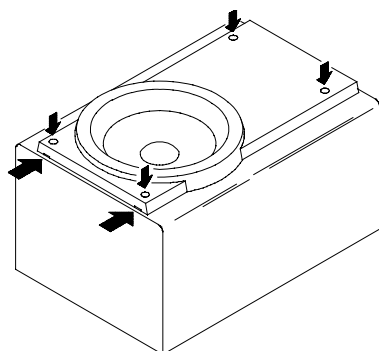

Type.3

Insert a flat-bladed screwdriver into the position indicated by the arrows and remove the panel. Turn the speaker unit to counter-clockwise direction while inserting a flat-bladed screwdriver into one of the hollows around speaker unit, and then remove the speaker unit. After replacing the speaker unit, install it turning to clockwise direction until "click" sound comes out.

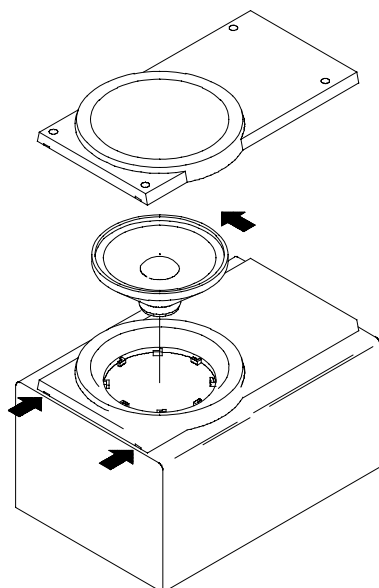

Type.4

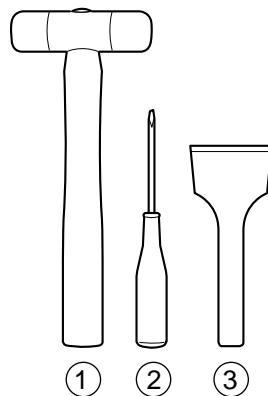

TOOLS

- ① Plastic head hammer
- ② (⊖) flat head screwdriver
- ③ Cut chisel

How to Remove the PANEL, FR

1. Insert the (⊖) flat head screwdriver tip into the gap between the PANEL, FR and the PANEL, SPKR. Tap the head of the (⊖) flat head screwdriver with the plastic hammer head, and create the clearance as shown in Fig-1.
2. Insert the cut chisel in the clearance, and tap the head of the cut chisel with plastic hammer as shown in Fig-2, to remove the PANEL, FR.
3. Place the speaker horizontally. Tap head of the cut chisel with plastic hammer as shown in Fig-3, and remove the PANEL, FR completely.

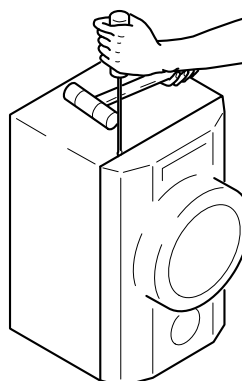

Fig-1

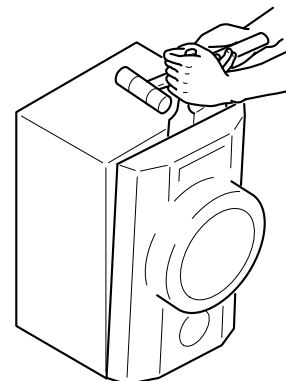

Fig-2

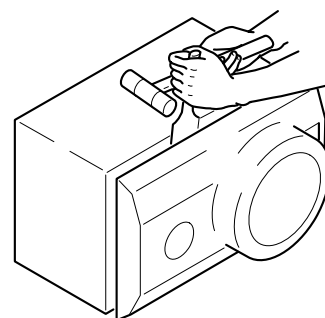

Fig-3

How to Attach the PANEL, FR

Attach the PANEL, FR to the PANEL, SPKR. Tap the four corners of the PANEL, FR with the plastic hammer to fit the PANEL, FR into the PANEL, SPKR completely.

SPEAKER PARTS LIST -1/1 <SX-NR40>

! = Δ SAFETY PARTS

C = Components marked

All components used on this model at the production line are shown in this service manual.

However, please note that not all components will be available as spare parts for after-sales service.

Components marked S and O are designated as spare parts for service and will be stocked at the spare parts centers.

Components marked X and R are not designated as spare parts for after sales service, and will not be stocked at the spare parts centers.

UNIT-NAME	! C	REF-NO	PARTS-NO	PARTS-NAME	SUFFIX&MODEL
					SX-SNR40
					YSN
	O	SP1001	88-NSK-610-010	SPKR, CERAMIC ASSY	a
	O	SP1002	8A-NSJ-006-010	BADGE,AIWA S35	a
	O	SP1003	8B-NSH-612-010	CORD,SPKR	a
	O	SP1004	8B-NSK-604-010	SPKR, T 60	a
	X	SP1005	8C-NS6-003-010	PROTECTOR, W	a
	X	SP1006	8C-NS7-003-010	LBL,SPEC YS	a
	O	SP1007	8C-NS7-004-010	PANEL,FR L	a
	O	SP1008	8C-NS7-005-010	PANEL,FR R	a
	O	SP1009	8C-NS7-604-010	SPKR, W 160 25/4	a
	O	SP1010	8C-NS8-003-010	PANEL,BA L	a
	O	SP1011	8C-NS8-004-010	PANEL,BA R	a
	X	SP1012	8Z-NS3-026-010	CORD,BUSH L	a
	X	SP1013	8C-NS7-851-010	CUSHION,ASSY TTC	a
	X	SP1014	PC-NS7-933-070	SX-SNR40 YSN	a

OTHER PARTS LIST -1/2

- ! = Δ SAFETY PARTS
- C = Components marked

All components used on this model at the production line are shown in this service manual.
 However, please note that not all components will be available as spare parts for after-sales service.
 Components marked S and O are designated as spare parts for service and will be stocked at the spare parts centers.
 Components marked X and R are not designated as spare parts for after sales service, and will not be stocked at the spare parts centers.

UNIT-NAME	! C	REF-NO	PARTS-NO	PARTS-NAME	SUFFIX&MODEL
					CX-SNR41
					EZSC
	X		87-B40-057-010	BAG,PP 0.03-150-200	a
	X		87-B40-098-010	BAG,PV 0.025-650-750 PL	a
	X		8C-NF8-851-010	CUSHION,FRONT USC	a
	X		8C-NF8-852-010	CUSHION,REAR USC	a
	X		92-370-716-010	SH,FOAMED-MAT 0.31-700-500	a
	X		87-B40-085-010	BAG,PV 0.04-200-350 PL	a
	X		87-B50-079-010	LIST,FACILITY(B)-0007	a
	X		8C-NF7-920-010	SH,ADDITIONAL REMOCON	a
	X		87-056-168-010	SH,CAUTION INF-WARR(EC)	a
	X		8C-NF8-979-010	LBL,POP EZR	a
	X		8C-NF7-974-010	LBL,POP KL	a
	X		87-B40-281-010	LBL,BAR-CODE A 35X8	a
	X		87-057-995-010	LBL,CAUTION EFSD	a
	X		87-057-961-010	LBL,CAUTION TRIANGLE	a
	X		8B-NF1-029-010	SH,FL	a

OTHER PARTS LIST -2/2 <TAPE MECHANISM ZZM-3 YPR4NC>

! = Δ SAFTY PARTS

C = Components marked

All components used on this model at the production line are shown in this service manual.

However, please note that not all components will be available as spare parts for after-sales service.

Components marked S and O are designated as spare parts for service and will be stocked at the spare parts centers.

Components marked X and R are not designated as spare parts for after sales service, and will not be stocked at the spare parts centers.

UNIT-NAME	! C	REF-NO	PARTS-NO	PARTS-NAME	SUFFIX&MODEL
					ZZM-3
					YPR4NC
	X		8Z-ZM3-858-010	CUSHION,BOTTOM C	a
	X		M8-ZZM-39F-070	ZZM-3 YPR4NC	a
	X		82-ZM3-987-010	BAG,PV 0.04-300-210	a
	X		8Z-ZM3-857-010	CTN,PRINTED YPR1NC	a
	X		8Z-ZM3-859-010	CUSHION,TOP C	a
	X		8Z-ZM3-603-010	PWB,COMB 6M C	a

アイワ株式会社 〒110-8710 東京都台東区池之端1-2-11 ☎03(3827)3111 (代表)
AIWA CO.,LTD. 2-11, IKENOHATA 1-CHOME, TAITO-KU, TOKYO 110-8710, JAPAN TEL:03 (3827) 3111

0251431