

aiwa

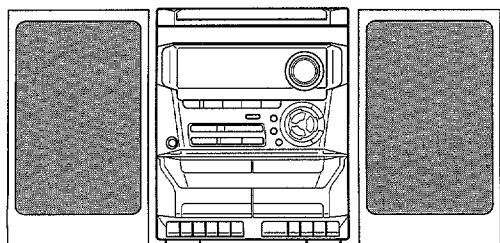

NSX-S111 NSX-S112 NSX-S116 NSX-S16



COMPACT DISC /
STEREO CASSETTE RECEIVER

- BASIC TAPE MECHANISM : TN-21ZFW-1815
- BASIC CD MECHANISM : 4ZG-1 Z3RNDSHJM, Z4RNDSHC
- TYPE : HR, HE, HC, HS
EZ, K, G, V

REVISION PUBLISHING

SYSTEM	SPEAKER	CD - CASSEIVER	REMOTE CONTROLLER
NSX-S111 (TYPE : HR, HE, HS)	SX-NS112	CX - NS111	RC UNIT ZAS02
NSX-S116 (TYPE : HC)	SX-NS116	CX - NA116	
NSX-S111 (TYPE : EZ, K, G, V)	SX-NS112	CX - NS111	
NSX-S112 (TYPE : EZ)		CX - NS112	
NSX-S16 (TYPE : EZ)	SX-NS116	CX - NS16	RC UNIT ZAS17
NSX-S116 (TYPE : EZ)		CX - NS116	

- This Service Manual is the "Revision Publishing" and replaces Simple Manual of NSX-S111<HE> (S/M Code No. 09-993-404-3T2), NSX-S111/S112/S116/S16<HR, EZ, K, G, V, HS> (S/M Code No. 09-991-404-3T3).
- If requiring information about the CD mechanism, see Service Manual of 4ZG-1 (S/M Code No. 09-992-325-4N2).

SERVICE MANUAL

SPECIFICATIONS

<FM Tuner section>

Tuning range HR,HE,HC,EZ,K,G,HS :
87.5 MHz to 108 MHz
V:
FM1 (OIRT)
65 MHz to 74 MHz(10 kHz step)
FM2 (CCIR)
87.5 MHz to 108 MHz(50 kHz step)

Usable sensitivity (IHF) HR,HE,HC : 13.2 dBf
EZ,K : 16.8 dBf
V: FM1 : 15.3 dBf
FM2 : 12.8 dBf

Antenna terminals 75 ohms (unbalanced)

<AM/MW Tuner section>

Tuning range 530 kHz to 1710 kHz (10 kHz step)
531 kHz to 1602 kHz (9 kHz step)

Usable sensitivity 350 μ V/m

Antenna Loop antenna

<SW Tuner section> (HR,HE,HC)

Tuning range 5.900 MHz to 17.900 MHz

Usable sensitivity 40 μ V(IEC)

Antenna Wire antenna

<LW Tuner section> (EZ,K,G,HS)

Tuning range 144 kHz to 290 kHz

Usable sensitivity 1400 μ V/m

Antenna Loop antenna

<Amplifier section>

Power output HR,HE,HC :
Rated : 10 W + 10 W (6 ohms, T.H.D.
1 %, 1 kHz)
Reference: 12W + 12W (6 ohms, T.H.D.
10 %, 1 kHz)

EZ,K,V,G,HS :
Rated : 10 W + 10 W (6 ohms, T.H.D.
1 %, 1 kHz/DIN 45500)
Reference: 12W + 12W (6 ohms, T.H.D.
10 %, 1 kHz/DIN 45324)
DIN MUSIC POWER: 29 W + 29 W

Total harmonic distortion 0.1% (6W, 1 kHz, 6ohms, DIN AUDIO)

Inputs VIDEO/AUX : 500 mV

HR,HE,HC only :

MIC: 1.8 mV (10 kohms)

Outputs

SPEAKERS:

accept speakers of 6 ohms or more

PHONES (stereo jack) :

accepts headphones of 32 ohms or more

<Cassette deck section>

Track format 4 tracks, 2 channels stereo

Frequency response 50 Hz - 8000 Hz

Recording system AC bias

Heads Deck 1 : Recording/playback X 1,
erase head x 1

Deck 2 : Playback head x 1

<Compact disc player section>

Laser Semiconductor laser ($\lambda = 780$ nm)

D-A converter 1 bit dual

Signal-to-noise ratio 85 dB (1 kHz, 0 dB)

Harmonic distortion 0.05% (1 kHz, 0 dB)

Wow and flutter Unmeasurable

<Speaker system SX-NS112 / SX-NS116>

Cabinet type 2way, bass reflex (magnetic shielded type)

Speakers Woofer : 120 mm cone type

Tweeter : 20 mm ceramic type

Impedance 6 ohms

Output sound pressure level 86 dB/W/m

Dimensions (W x H x D) 220 x 324 x 235 mm

Weight 2.0 kg

<General>

Power requirements HR,HE,HC :
120V / 220-230V / 240V AC,
switchable, 50/60 Hz

K,V,EZ,G,HS : 230V AC, 50Hz

Power consumption HR,HE,HC,EZ,V,HS : 50W

K,G : 55 W

Dimensions of main unit 260 x 324 x 349.5 mm

($10\frac{1}{4}$ x $12\frac{7}{8}$ x $13\frac{7}{8}$ in.)

Weight of main unit 4.9 kg

• Design and specifications are subject to change without notice.

PROTECTION OF EYES FROM LASER BEAM DURING SERVICING

This set employs laser. Therefore, be sure to follow carefully the instructions below when servicing.

WARNING!!

WHEN SERVICING, DO NOT APPROACH THE LASER EXIT WITH THE EYE TOO CLOSELY. IN CASE IT IS NECESSARY TO CONFIRM LASER BEAM EMISSION. BE SURE TO OBSERVE FROM A DISTANCE OF MORE THAN 30cm FROM THE SURFACE OF THE OBJECTIVE LENS ON THE OPTICAL PICK-UP BLOCK.

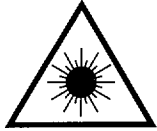

- Caution: Invisible laser radiation when open and interlocks defeated avoid exposure to beam.
- Advarsel: Usynlig laserstråling ved åbning, når sikkerhedsafbrydere er ude af funktion. Undgå udsættelse for stråling.

VAROITUS!

Laiteen Käyttäminen muulla kuin tässä käyttöohjeessa mainitulla tavalla saattaa altistaa käyt-täjän turvallisuusluokan 1 ylittävälle näkymättömälle lasersäteilylle.

WARNING!

Om apparaten används på annat sätt än vad som specificeras i denna bruksanvisning, kan användaren utsättas för osynlig laserstråling, som överskrider gränsen för laserklass 1.

CAUTION

Use of controls or adjustments or performance of procedures other than those specified herein may result in hazardous radiation exposure.

ATTENTION

L'utilisation de commandes, réglages ou procédures autres que ceux spécifiés peut entraîner une dangereuse exposition aux radiations.

ADVARSEL

Usynlig laserstråling ved åbning, når sikkerhedsafbrydere er ude af funktion. Undgå udsættelse for stråling.

This Compact Disc player is classified as a CLASS 1 LASER product.
The CLASS 1 LASER PRODUCT label is located on the rear exterior.

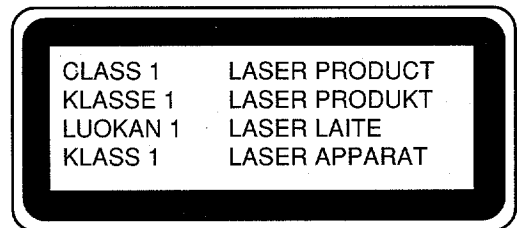

Precaution to replace Optical block

(KSS-213F) <Z3RNDSHJ>
(KSS-213IFAM) <Z4RNDSH>

Body or clothes electrostatic potential could ruin laser diode in the optical block. Be sure to ground body and workbench, and ensure clothes do not touch the diode.

- 1) After the connection, remove solder shown in right figure.

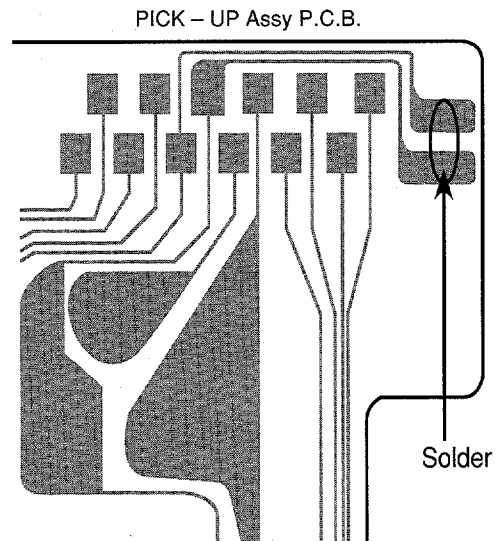

NOTE ON BEFORE STARTING REPAIR

1. Forced discharge of electrolytic capacitor of power supply block

When repair is going to be attempted in the set that uses relay circuit in the power supply block, electric potential is kept charged across the electrolytic capacitors (C101, 102) even though AC power cord is removed. If repair is attempted in this condition, secondary defect can occur.

In order to prevent the secondary trouble, perform the following measures before starting repair work.

Discharge procedure

- ① Remove the AC power cord.
- ② Connect a discharging resistor at an end of lead wire that has clips at both ends. Connect the other end of the lead wire to metal chassis.
- ③ Contact the other end of the discharging resistor to the positive (+) side (+VH) of C101. (For two seconds)
- ④ Contact the same end of the discharging resistor as step ③ to the negative (-) side (-VH) of C102 in the same way. (For two seconds)
- ⑤ Check that voltage across C101 and C102 has decreased to 1 V or less using a multimeter or an oscilloscope.

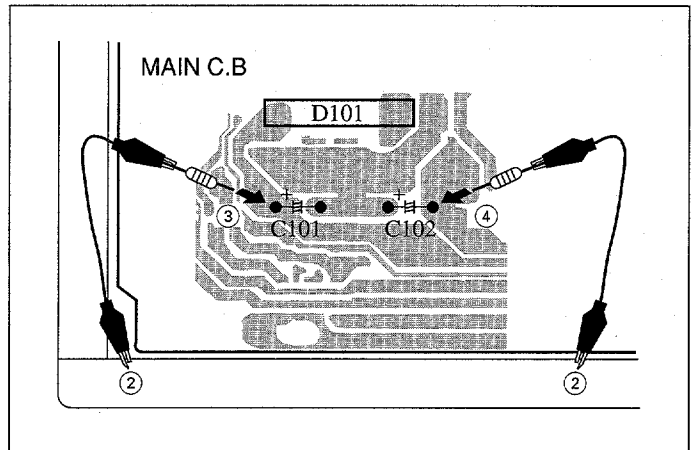

Fig-1

Select a discharging resistor referring to the following table.

Charging voltage (V) (C101, 102)	Discharging resistor (Ω)	Rated power (W)	Parts number
25-48	100	3	87-A00-247-090
49-140	220	5	87-A00-232-090

Note: The reference numbers (C101, C102) of the electrolytic capacitors can change depending on the models. Be sure to check the reference numbers of the charging capacitor on schematic diagram before starting the discharging work.

2. Check items before exchanging the MICROCOMPUTER

Be sure to check the following items before exchanging the MICROCOMPUTER. Exchange the MICROCOMPUTER after confirming that the MICROCOMPUTER is surely defective.

2-1. Regarding the HOLD terminal of the MICROCOMPUTER

When the HOLD terminal (INPUT) of the MICROCOMPUTER is "H", the MICROCOMPUTER is judged to be operating correctly. When this terminal is "L", the main power cannot be turned on. Therefore, be sure to check the terminal voltage of the HOLD terminal before exchange.

When the MICROCOMPUTER is not defective, the HOLD terminal can also go "L" when the POWER AMPLIFIER has any abnormalities that triggers the abnormality detection circuit on the MAIN C. B. that sets the HOLD terminal to "L".

• Good or no good judgment of the MICROCOMPUTER

- ① Turn on the AC main power.
- ② Confirm that the main power is turned on and the HOLD terminal of the MICROCOMPUTER keeps the "H" level or not.
- ③ When the HOLD terminal is "L" level, the abnormality detection circuit is judged to be working correctly and the MICROCOMPUTER is judged to be good.

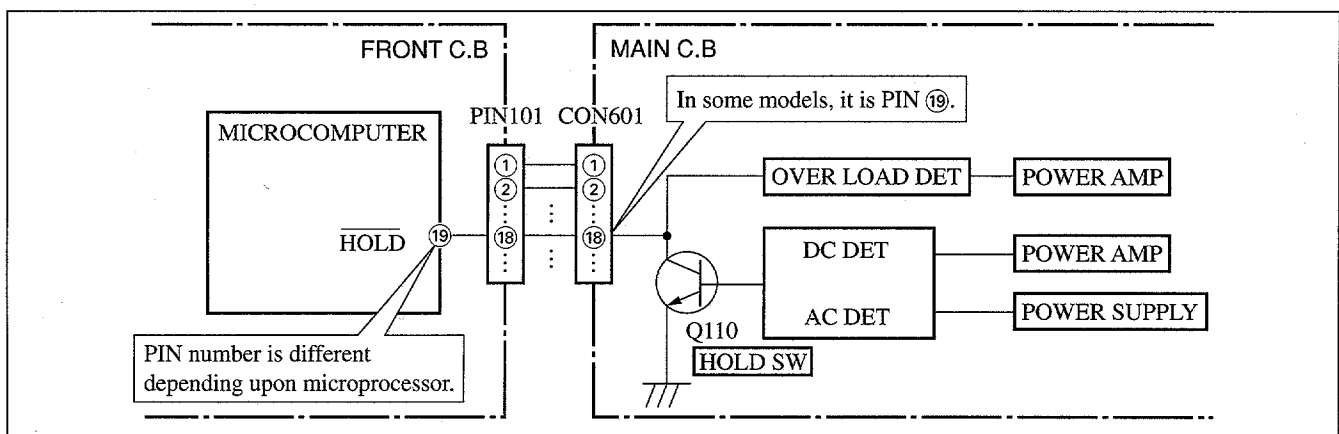

Fig-2-1

In such a case, check also if the POWER AMPLIFIER circuit or power supply circuit has any abnormalities or not.

2-2. Regarding reset

There are cases that the machine does not work correctly because the MICROCOMPUTER is not reset even though the AC power cord is re-inserted, or the software reset (pressing the STOP key + POWER key) is performed.

When the above described phenomenon occurs, it can lead to wrong judgment as if the MICROCOMPUTER is defective and to exchange the MICROCOMPUTER. In such a case, perform the forced-reset by the following procedure and check good or no good of the MICROCOMPUTER.

- ① Remove the AC power cord.

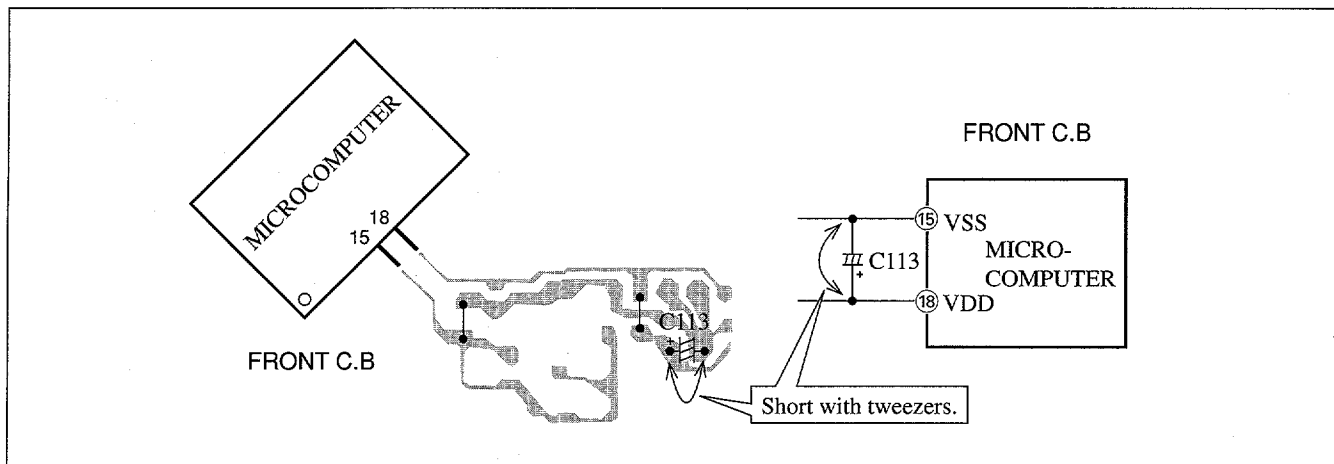

Fig-2-2

- ② Short both ends of the electrolytic capacitor C113 that is connected to VDD of the MICROCOMPUTER with tweezers.
- ③ Connect the AC power cord again. If the MICROCOMPUTER returns to the normal operation, the MICROCOMPUTER is good.

Note: The reference number or MICROCOMPUTER pin number of transistor (Q110) and electrolytic capacitor (C113) can change depending on the models. Be sure to check the reference numbers on schematic diagram before starting the discharging work.

2-3. Confirmation of soldering state of MICROCOMPUTER

Check the soldering state of the MICROCOMPUTER in addition to the above described procedures. Be sure to exchange the MICROCOMPUTER after surely confirming that the trouble is not caused by poor soldering but the MICROCOMPUTER itself.

ELECTRICAL MAIN PARTS LIST

If can't understand for Description please kindly refer to "REFERENCE NAME LIST".

REF. NO.	PART NO.	KANRI NO.	DESCRIPTION	REF. NO.	PART NO.	KANRI NO.	DESCRIPTION
IC				C220	87-010-544-080		CAP, ELECT 0.1-50V
	8Z-NFA-661-010	C-IC, M38B59MFH-P113FP		C221	87-018-211-080		CAP, CER 0.01-50<EZ, K, V, G, HS>
	87-A21-218-010	IC, NJL64H380A		C222	87-018-211-080		CAP, CER 0.01-50<EZ, K, V, G, HS>
	87-017-889-010	IC, NJM4558LD		C229	87-018-123-080		CAP, CER 220P-50V
	87-A20-715-010	IC, M62439SP		C235	87-A11-148-080		CAP, TC 0.1-50 ZF
	87-070-127-110	IC, LC72131 D		C236	87-A11-148-080		CAP, TC 0.1-50 ZF
	87-A20-913-010	IC, LA1837NL		C237	87-A11-155-080		CAP, TC 0.01-16 Z F
	87-A20-502-01	IC, BU1920<112EZ>		C253	87-018-131-080		CAP, CER 1000P<EZ, K, V, G, HS>
				C254	87-018-131-080		CAP, CER 1000P<EZ, K, V, G, HS>
				C255	87-018-115-080		CAP, CER 47P<EZ, K, V, G, HS>
TRANSISTOR				C256	87-018-115-080		CAP, CER 47P<EZ, K, V, G, HS>
	87-026-214-080	TR, DTA114YS (0.3W)		C257	87-018-119-080		CAP, CER 100P<EZ, K, V, G, HS>
	87-026-219-080	TR, DTA144ES (0.3W)		C258	87-018-119-080		CAP, CER 100P<EZ, K, V, G, HS>
	87-026-269-080	TR, DTA114ES		C301	87-018-195-080		CAP, CER 1200P-50V
	87-026-610-080	TR, KTC3198GR		C302	87-018-195-080		CAP, CER 1200P-50V
	87-026-609-080	TR, KTA1266GR		C303	87-018-195-080		CAP, CER 1200P-50V
	87-A30-127-010	TR, 2SD2478		C304	87-018-195-080		CAP, CER 1200P-50V
	87-A30-126-010	TR, 2SB1616		C307	87-010-263-080		CAP, ELECT 100-10V
	87-A30-164-080	TR, CSC2001K		C308	87-010-263-080		CAP, ELECT 100-10V
	87-A30-234-080	TR, CSC4115BC		C309	87-018-115-080		CAP, CER 47P-50V<EZ, K, V, G, HS>
	87-A30-091-080	FET, 2SJ460		C310	87-018-115-080		CAP, CER 47P-50V<EZ, K, V, G, HS>
	87-A30-090-080	FET, 2SK2541		C311	87-A10-307-080		CAP, M 0.1-50 J
	87-A30-092-080	FET, 2SK439 (E/F) <EXCEPT V>		C312	87-A10-307-080		CAP, M 0.1-50 J
				C315	87-010-374-080		CAP, ELECT 47-10V
				C317	87-010-546-080		CAP, ELECT 0.33-50V
DIODE				C318	87-010-546-080		CAP, ELECT 0.33-50V
	87-020-465-080	DIODE, 1SS133 (110MA) <EXCEPT HC>		C326	87-018-205-080		CAP, CERA-SOL 0.022
	87-A40-291-080	DIODE, 1N4148 (CPT) <HC ONLY>		C327	87-A11-148-080		CAP, TC U 0.1-50
	87-A40-393-090	DIODE, 1N5402GW (F20)		C360	87-010-401-080		CAP, ELECT 1-50V
	87-A40-553-080	DIODE, 1N4003 LES		C361	87-010-374-080		CAP, ELECT 47-10V
	87-017-932-080	ZENER, MTJ6.2B		C399	87-018-127-080		CAP, CER 470P-50V
	87-A40-336-080	ZENER, MTZJ27D T-72		C401	87-010-545-080		CAP, ELECT 0.22-50V
	87-A40-345-080	ZENER, MTZJ10C		C402	87-010-545-080		CAP, ELECT 0.22-50V
	87-A40-466-080	ZENER, MTZJ2.7A		C403	87-018-118-080		CAP, TC-U 82P-50 B
	87-017-931-080	ZENER, MTZJ5.6B		C404	87-018-118-080		CAP, TC-U 82P-50 B
				C411	87-010-405-080		CAP, ELECT 10-50V
				C412	87-010-405-080		CAP, ELECT 10-50V
				C452	87-010-382-080		CAP, E 22-25V
				C458	87-018-131-080		CAP, CER 1000P-50V
MAIN C.B				C459	87-018-128-080		CAP, TC U 560P-50 K B
C101	87-016-495-090	CAP, E 3300-25 SMG		C461	87-018-126-080		CAP, TC-U 390P-50 B
C103	87-016-051-090	CAP, E 2200-35 SMG<EZ, K, V, G, HS>		C462	87-018-126-080		CAP, TC-U 390P-50 B
C104	87-A10-011-090	CAP, E 2200-25 SMG<HE, HR, HC>		C601	87-018-195-080		CAP, CER 1200P-16V
C105	87-018-127-080	CAP, CER 470P-50V		C602	87-018-195-080		CAP, CER 1200P-16V
C106	87-010-260-080	CAP, E 47-25 SME		C611	87-010-545-080		CAP, ELECT 0.22-50V
C107	87-010-384-080	CAP, ELECT 100-25V		C612	87-010-545-080		CAP, ELECT 0.22-50V
C108	87-010-381-080	CAP, ELECT 330-16V		C613	87-010-545-080		CAP, ELECT 0.22-50V
C111	87-010-247-080	CAP, E 100-50V		C614	87-010-545-080		CAP, ELECT 0.22-50V
C112	87-010-263-080	CAP, ELECT 100-10V		C615	87-018-104-080		CAP, TC-U 10P-50 SL
C113	87-010-403-080	CAP, ELECT 3.3-50V		C616	87-010-260-080		CAP, ELECT 47-25V
C114	87-010-374-080	CAP, ELECT 47-10V		C617	87-010-260-080		CAP, ELECT 47-25V
C115	87-A10-303-080	CAP, M 0.047-50 J		C701	87-010-404-080		CAP, ELECT 4.7-50V
C116	87-A10-303-080	CAP, M 0.047-50 J		C702	87-A11-155-080		CAP, TC U 0.01-16 Z F
C122	87-010-384-080	CAP, E 100-25V		C703	87-A11-155-080		CAP, TC U 0.01-16 Z F
C123	87-010-384-080	CAP, E 100-25V		C704	87-018-131-080		CAP, CER 1000P-50V
C124	87-A11-132-080	CAP, TC U 0.01 K B		C705	87-018-131-080		CAP, CER 1000P-50V
C127	87-A11-155-080	CAP, TC U 0.01-16ZF<EZ, K, V, G, HS>		C706	87-018-131-080		CAP, CER 1000P-50V
C130	87-018-131-080	CAP, TC U 1000P-50 K B<V>		C707	87-010-112-080		CAP, ELECT 100-16V
C152	87-010-388-010	CAP, E 1000-25V<HR, HE, HC>		C708	87-A11-144-080		CAP, TC U 0.1-50 K B
C207	87-010-545-080	CAP, ELECT 0.22-50V		C709	87-010-248-080		CAP, ELECT 220-10V
C208	87-010-545-080	CAP, ELECT 0.22-50V		C710	87-010-112-080		CAP, ELECT 100-16V
C209	87-A11-154-080	CAP, TC U 4700P-16 Z F		C712	87-018-149-080		CAP, TC-U 15P-50 CH
C210	87-A11-154-080	CAP, TC U 4700P-16 Z F		C713	87-018-149-080		CAP, TC-U 15P-50 CH
C211	87-010-403-080	CAP, ELECT 3.3-50V		C714	87-010-112-080		CAP, ELECT 100-16V
C212	87-010-403-080	CAP, ELECT 3.3-50V		C715	87-018-119-080		CAP, CER 100P-50V
C213	87-010-260-080	CAP, ELECT 47-25V		C746	87-A11-155-080		CAP, TC U 0.01-16 Z F
C214	87-010-260-080	CAP, ELECT 47-25V		C751	87-A11-155-080		CAP, TC U 0.01-16ZF<EZ, K, V, G, HS>
C217	87-A10-304-080	CAP, M 0.056-50 J		C752	87-018-143-080		CAP, TC 4.7P-50CH<EZ, K, V, G, HS>
C218	87-A10-304-080	CAP, M 0.056-50 J		C753	87-010-408-080		CAP, ELECT 47-50V
C219	87-010-544-080	CAP, ELECT 0.1-50V		C755	87-A11-144-080		CAP, TC U 0.1-50 K B

* NOTE : 1EZ = 111EZ,116EZ,16EZ

REF. NO.	PART NO.	KANRI NO.	DESCRIPTION	REF. NO.	PART NO.	KANRI NO.	DESCRIPTION
C756	87-A11-155-080		CAP,TC U 0.01-16 Z F	C943	87-A11-144-080		CAP,TC U 0.1-50 K B
C757	87-A11-155-080		CAP,TC U 0.01-16 Z F	C944	87-018-104-080		CAP,TC-U 10P-50 SL<V>
C758	87-010-112-080		CAP, ELECT 100-16V	CF801	87-008-261-010		FLTR, SFE10.7MA5<HR,HE,HC,V>
C759	87-A11-155-080		CAP,TC U 0.01-16ZF<EZ,K,V,G,HS>	CF801	87-008-423-010		FLTR, SFE10.7MS3G-A<EZ,K,G,HS>
C761	87-010-404-080		CAP, ELECT 4.7-50V	CF802	82-785-747-010		CF MS2 GHY R<EZ,K,G,HS>
C762	87-010-400-080		CAP, ELECT 0.47-50V	CF802	87-008-261-010		FLTR, SFE10.7MA5-A<V>
C763	87-010-401-080		CAP, ELECT 1-50V	CN301	87-A60-620-010		CONN,3P V 2MM JMT
C764	87-010-401-080		CAP, ELECT 1-50V	CN351	87-A60-625-010		CONN,8P V 2MM JMT
C765	87-018-115-080		CAP, CER 47P-50V	CN601	88-NF9-657-010		CONN,30P H BLK TYK-B(X)
C766	87-010-407-080		CAP, ELECT 33-50V	CN602	87-099-194-010		CONN,6P 6216V
C768	87-A11-147-080		CAP,TC U 0.047-50 Z F	D981	87-A40-618-080		VARI-CAP,SVC 348(S/T)<HR,HE,HC>
C769	87-010-403-080		CAP, ELECT 3.3-50V	FB601	87-008-372-080		FLTR,EMI BLOIRNI<EZ,K,V,G,HS>
C770	87-A11-155-080		CAP,TC U 0.01-16 Z F	FB603	87-008-474-080		F-BEAD,EMI BLO2RN1<EZ,K,V,G,HS>
C771	87-010-406-080		CAP, ELECT 22-50	FB813	87-008-372-080		FLTR,EMI BLOIRNI<EZ,K,V,G,HS>
C773	87-018-130-080		CAP, TC 820P-50<HR,HE,HC>	FCC1	88-906-251-110		FF-CABLE,6P 1.25
C773	87-018-131-080		CAP, TC 1000P-50<V>	FFE801	A8-8ZA-192-070		8ZA-1 FEUNC<HC>
C773	87-018-195-080		CAP, TC 1200P-16<112EZ>	FFE801	A8-8ZA-190-030		8ZA-1 FEUNM<HR,HE>
C773	87-018-196-080		CAP, TC 1500P-16<1EZ,K,G,HS>	FFE801	A8-6ZA-193-030		6ZA-1 FEVNM<V>
C774	87-010-405-080		CAP, ELECT 10-50V	FFE801	A8-6ZA-191-130		6ZA-1 FEENM<EZ,K,G,HS>
C776	87-A11-155-080		CAP,TC U 0.01-16 Z F	J201	87-A60-602-010		JACK,DIA6.3 BLK ST W/SW TC
C783	87-018-199-080		CAP, CER 3300P<HR,HE,HC,V>	J202	87-A60-238-010		TERMINAL,SP 4P (MSC)
C783	87-018-202-080		CAP.CERAM.6800PF<EZ,K,G,HS>	J601	87-A60-881-010		JACK,PIN 2P MSP 242V05 PBSN
C784	87-018-199-080		CAP, CER 3300P<HR,HE,HC,V>	J801	87-A60-202-010		TML,ANT4P MSP<HR,HE,HC,V>
C784	87-018-202-080		CAP.CERAM.6800PF<EZ,K,G,HS>	J802	87-A60-403-010		TML,ANTPAL 2P<EZ,K,G,HS>
C785	87-010-405-080		CAP, ELECT 10-50V	J931	81-754-629-010		CONNECTOR, 2P<HR,HE,HC>
C786	87-010-405-080		CAP, ELECT 10-50V	L201	87-003-383-010		COIL,1UH-S
C787	87-018-196-080		CAP, TC 1500P-16	L202	87-003-383-010		COIL,1UH-S
C788	87-018-196-080		CAP, TC 1500P-16	L451	87-007-342-010		COIL,OSC 85K BIAS
C789	87-010-403-080		CAP, ELECT 3.3-50V<HR,HE,HC,V>	L701	87-005-847-080		COIL,2.2UH(CECS)
C789	87-010-546-080		CAP, ELECT 0.33-50M<EZ,K,G,HS>	L706	87-005-849-080		COIL,10UH(CECS) <HR>
C790	87-010-403-080		CAP, ELECT 3.3-50V<HR,HE,HC,V>	L771	87-A50-266-010		COIL,FM DET-2N(TOK)
C790	87-010-546-080		CAP, ELECT 0.33-50M<EZ,K,G,HS>	L772	87-A90-052-010		FLTR,CFMT-450A(TOK)<HR,HE,HC>
C801	87-A11-155-080		CAP,TC 0.01-16ZF<EZ,K,G,HS>	L772	87-A91-110-010		FLTR,PCFJZH-450(T)<EZ,K,V,G,HS>
C802	87-A11-155-080		CAP,TC 0.01-16ZF<EZ,K,G,HS>	L766	87-005-849-080		COIL,10UH(CECS)
C803	87-A11-155-080		CAP,TC 0.01-16ZF<EZ,K,G,HS>	L801	87-005-847-080		COIL,2.2UH(CECS)
C804	87-A11-155-080		CAP,TC 0.01-16ZF<EZ,K,G,HS>	L802	87-005-849-080		COIL,10UH K CECS <V>
C805	87-A11-144-080		CAP,TC 0.1-50KB	L851	87-005-847-080		COIL,2.2UH(CECS)<112EZ>
C807	87-A11-144-080		CAP,TC U 0.1-50KB	L933	87-A50-159-010		COIL,10MH K C2B<HR,HE,HC>
C808	87-A11-155-080		CAP,TC U 0.01-16 Z F	L934	87-005-372-080		COIL S 1MHM<HR,HE,HC>
C809	87-A11-155-080		CAP,TC 0.01-16ZF<EZ,K,V,G,HS>	L941	87-A50-020-010		COIL,ANT LW(COI)<EZ,K,G,HS>
C810	87-A11-155-080		CAP,TC 0.01-16ZF<EZ,K,V,G,HS>	L941	87-A50-022-010		COIL,ANT SW(COI)<HR,HE,HC>
C811	87-A11-155-080		CAP,TC 0.01-16ZF<EZ,K,V,G,HS>	L942	87-A50-019-010		COIL,OSC LW(COI)<EZ,K,G,HS>
C812	87-010-408-080		CAP,E 47-50V<EZ,K,V,G,HS>	L942	87-A50-173-010		COIL,OSC SW-N(COI)<HR,HE,HC>
C813	87-018-131-080		CAP, CER 1000P-50V	L957	87-005-849-080		COIL,10UH K CECS<HR,HE,HC>
C851	87-018-123-080		CAP, CER 220P-50V<112EZ>	L981	8Z-NFA-665-010		COIL,AMPAK 2L<EZ,K,G,HS>
C852	87-018-123-080		CAP, CER 220P-50V<112EZ>	L981	8Z-NFA-664-010		COIL,AMPAK 4L<V>
C853	87-018-127-080		CAP, CER 470P-50V<112EZ>	L982	87-A50-431-010		COIL,OSC MW(3BSW)<HR,HE,HC>
C854	87-A11-144-080		CAP,TC U 0.1-50 K B<112EZ>	L983	87-A50-430-010		COIL,ANT MW(3BSW)<HR,HE,HC>
C855	87-010-405-080		CAP, ELECT 10-50V<112EZ>	R249	87-A00-258-080		RES,M/F 0.22-1WJ
C856	87-010-405-080		CAP, ELECT 10-50V<112EZ>	R250	87-A00-258-080		RES,M/F 0.22-1WJ
C857	87-018-134-080		CAP,TC U 0.01-16 N Y<112EZ>	RY101	87-045-389-010		RELAY,12V OSA-SS-212DMS
C858	87-018-109-080		CAP, CER 22P-50V<112EZ>	TC941	87-011-220-080		TRIMMER CAP 20P VTC<HR,HE,HC>
C859	87-018-109-080		CAP, CER 22P-50V<112EZ>	TC942	87-011-221-080		CAP,TRMR 30P<except V>
C860	87-018-134-080		CAP,TC U 0.01-16 N Y<112EZ>	W101	83-NE2-618-110		F-CABEL,5P-2.5
C901	87-A11-148-080		CAP,TC U 0.1-50 ZF<EZ,K,V,G,HS>	WH102	87-A90-459-010		HLDR,WIRE 2.5-5P
C901	87-A11-149-080		CAP,TC U 0.22-50 ZF<HR,HE,HC>	X701	87-A70-061-010		VIB,XTAL 4.500MHZ CSA-309
C921	87-A11-155-080		CAP,TC 0.01-16ZF<EZ,K,G,HS>	X751	87-030-354-010		VIB,CF BFU 450C<HR,HE,HC>
C922	87-018-099-080		CAP CERA 3.9P-50<EZ,K,G,HS>	X851	87-A70-091-010		VIB,XTAL 4.332MHZ<112EZ>
C923	87-018-101-080		CAP,TC-U 5.6P-50<EZ,K,G,HS>				
C924	87-014-049-080		CAP,PP 470P-100 J<EZ,K,G,HS>				
FRONT C.B							
C931	87-010-263-080		CAP, ELECT 100-10V<HR,HE,HC>	C101	87-A11-147-080		CAP,TC U 0.047-50 Z F
C932	87-010-400-080		CAP, ELECT 0.47-50V<HR,HE,HC>	C102	87-A11-147-080		CAP,TC U 0.047-50 Z F
C934	87-A11-155-080		CAP,TC U 0.01-16 Z F<HR,HE,HC>	C103	87-015-699-040		CAP,E 10-50 7L
C935	87-A11-155-080		CAP,TC U 0.01-16 Z F<HR,HE,HC>	C104	87-010-246-040		CAP,E 47-35 SME
C936	87-A11-155-080		CAP,TC U 0.01-16 Z F<HR,HE,HC>	C105	87-018-205-080		CAP, CERA-SOL 0.022
C937	87-A11-155-080		CAP,TC U 0.01-16 Z F<except V>	C110	87-018-205-080		CAP, CERA-SOL 0.022
C938	87-A11-155-080		CAP,TC U 0.01-16 Z F<except V>	C111	87-A11-155-080		CAP,TC U 0.01-16 Z F
C939	87-014-073-080		CAP,PP 4700P-100 J<HR,HE,HC>	C112	87-018-131-080		CAP, CER 1000P-50V
C940	87-014-051-080		CAPACITOR (PP), 560P<HR,HE,HC>	C113	87-018-205-080		CAP, CERA-SOL 0.022
C941	87-018-109-080		CAP, CER 22P-50V<HR,HE,HC>	C114	87-018-205-080		CAP, CERA-SOL 0.022

REF. NO.	PART NO.	KANRI NO.	DESCRIPTION	REF. NO.	PART NO.	KANRI NO.	DESCRIPTION
C115	87-018-205-080		CAP, CERA-SOL 0.022	S303	87-A90-164-080		SW, TACT SKQAB (N)
C116	87-018-128-080		CAP, CERA-SOL SS 560P	S304	87-A90-164-080		SW, TACT SKQAB (N)
C118	87-018-147-080		CAP, TC-U 10P-50 CH	S305	87-A90-164-080		SW, TACT SKQAB (N)
C119	87-010-401-040		CAP, E 1-50 SME	S306	87-A90-164-080		SW, TACT SKQAB (N)
C120	87-018-205-080		CAP, CERA-SOL 0.022	S307	87-A90-164-080		SW, TACT SKQAB (N)
C121	87-010-248-040		CAP, E 220-10 SME	S308	87-A90-164-080		SW, TACT SKQAB (N)
C122	87-010-378-040		CAP, E 10-16	S309	87-A90-164-080		SW, TACT SKQAB (N)
C123	87-A11-147-080		CAP, TC U 0.047-50 Z F	S310	87-A90-164-080		SW, TACT SKQAB (N) <112EZ>
C124	87-A11-152-080		CAP, TC U 1000P-50 Z F	S311	87-A90-164-080		SW, TACT SKQAB (N) <112EZ>
C201	87-018-118-080		CAP, TC-U 82P-50 B	S312	87-A90-164-080		SW, TACT SKQAB (N) <112EZ>
C202	87-018-117-080		CAP, TC-U 68P-50 SL	S321	87-A90-164-080		SW, TACT SKQAB (N)
C205	87-018-117-080		CAP, TC-U 68P-50 SL	S322	87-A90-164-080		SW, TACT SKQAB (N)
C208	87-018-117-080		CAP, TC-U 68P-50 SL	S323	87-A90-164-080		SW, TACT SKQAB (N)
C209	87-018-117-080		CAP, TC-U 68P-50 SL	S324	87-A90-164-080		SW, TACT SKQAB (N)
C210	87-018-117-080		CAP, TC-U 68P-50 SL	S325	87-A90-164-080		SW, TACT SKQAB (N)
C211	87-A11-147-080		CAP, TC U 0.047-50 Z F	S326	87-A90-164-080		SW, TACT SKQAB (N)
C213	87-010-421-040		CAP, E 4.7-50 5L	S327	87-A90-164-080		SW, TACT SKQAB (N)
C214	87-010-404-040		CAP, E 4.7-50 SME	S328	87-A90-164-080		SW, TACT SKQAB (N)
C401	87-A11-154-080		CAP, TC U 4700P-16 ZF<HR, HR, HC>	S329	87-A90-164-080		SW, TACT SKQAB (N)
C402	87-010-060-040		CAP, E 100-16<HR, HR, HC>	S330	87-A90-164-080		SW, TACT SKQAB (N)
C403	87-015-692-040		CAP, E 0.22-50M<HR, HR, HC>	SFR701	87-024-350-080		SFR 2.2K DIA 6H
C404	87-018-119-080		CAP, TC-U 100P-50 SL<HR, HR, HC>	VR401	87-NB7-602-010		VR, RTRY 10KAX1 1 V
C405	87-015-692-040		CAP, E 0.22-50M<HR, HR, HC>				
C406	87-A11-148-080		CAP, TC U 0.1-50 ZF<HR, HR, HC>				
C408	87-018-119-080		CAP, TC-U 100P-50 B<HR, HR, HC>				AC1 C.B
C409	87-010-378-040		CAP, E 10-16 SME<HR, HR, HC>	△ F101	87-035-359-010		FUSE, 500MA 250V T<EZ, K, V, G, HS>
C410	87-A11-147-080		CAP, TC U 0.047-50<HR, HR, HC>	△ F101	87-A91-208-010		FUSE, 400MA 250V T 50T<HR, HE, HC>
C413	87-A11-110-080		CAP, TC 820P-50V<HR, HR, HC>	△ FC1	87-033-213-080		CLAMP, FUSE<EZ, K, G, V, HS>
C301	87-A11-148-080		CAP, TC U 0.1-50 Z F<HR, HE, HC>	△ FC2	87-033-213-080		CLAMP, FUSE<EZ, K, G, V, HS>
C701	87-010-384-040		CAP, E 100-25 SME	△ FC101	87-033-147-010		FUSE CLAMP<HR, HE, HC>
C702	87-A11-155-080		CAP, TC U 0.01-16 Z F	△ FC102	87-033-147-010		FUSE CLAMP<HR, HE, HC>
CN101	88-NF9-658-010		CONN, 30P BLK TYK-B(P)	△ PT101	8Z-NFA-623-110		PT, HR EI57-35 ZNF-A<HR, HE, HC>
CN701	87-A60-674-010		CONN, 10P H 2MM JMT	△ PT101	8Z-NFA-625-110		PT, E EI57-35 ZNF-A<EZ, K, V, G, HS>
CN801	87-099-015-010		CONN, 13P 6216V	△ SW101	87-A90-165-010		SW, SL 1-2-3 SWS2301<HR, HE, HC>
EMI401	87-008-372-080		FILTER, EMI BL OIRNI<HR, HR, HC>	△ T1	87-A60-317-010		TERMINAL, 1P MSC<EZ, K, V, G, HS>
FCC2	88-913-221-110		FF-CABLE, 13P 1.25 220MM	△ T2	87-A60-317-010		TERMINAL, 1P MSC<EZ, K, V, G, HS>
FL201	8Z-NFA-630-010		FL, 10-BT-207GAK	△ T101	87-A60-317-010		TERMINAL, 1P MSC<HR, HE, HC>
J401	87-A60-651-010		JACK, 3.5MONO<HR, HR, HC>	△ T102	87-A60-317-010		TERMINAL, 1P MSC<HR, HE, HC>
L101	87-A50-050-010		COIL, CLK 4.19M(COI)				
S101	87-A90-535-010		SW, RTRY EC16B24304				
S301	87-A90-164-080		SW, TACT SKQAB (N)				AC2 C.B
S302	87-A90-164-080		SW, TACT SKQAB (N)	WH101	87-A90-459-010		HLDR, WIRE 2.5-5P

チップ抵抗部品コード/CHIP RESISTOR PART CODE

チップ抵抗部品コードの成り立ち

Chip Resistor Part Coding



A
抵抗部品コード
Resistor Code

桁表示
Figure
抵抗値
Value of resistor

チップ抵抗
Chip resistor

容量 Wattage	種類 Type	許容誤差 Tolerance	記号 Symbol	寸法/Dimensions (mm)			抵抗コード : A Resistor Code : A	
				外形/Form	L	W		t
1/16W	1005	± 5%	CJ		1.0	0.5	0.35	104
1/16W	1608	± 5%	CJ		1.6	0.8	0.45	108
1/10W	2125	± 5%	CJ		2	1.25	0.45	118
1/8W	3216	± 5%	CJ		3.2	1.6	0.55	128

TRANSISTOR ILLUSTRATION

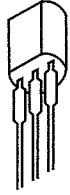

E C B

KTA1266GR
KTC3198GR



E C B

CSC2001K



E C B

DTA114YS
DTA114ES
DTA144ES

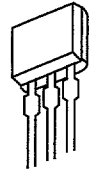

B C E

CSC4115BC

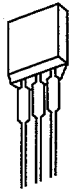

S D G

2SK2541
2SK439E/F



S D G

2SJ460



B C E

2SB1616
2SD2478

IC BLOCK DIAGRAM
IC, LA1837NL

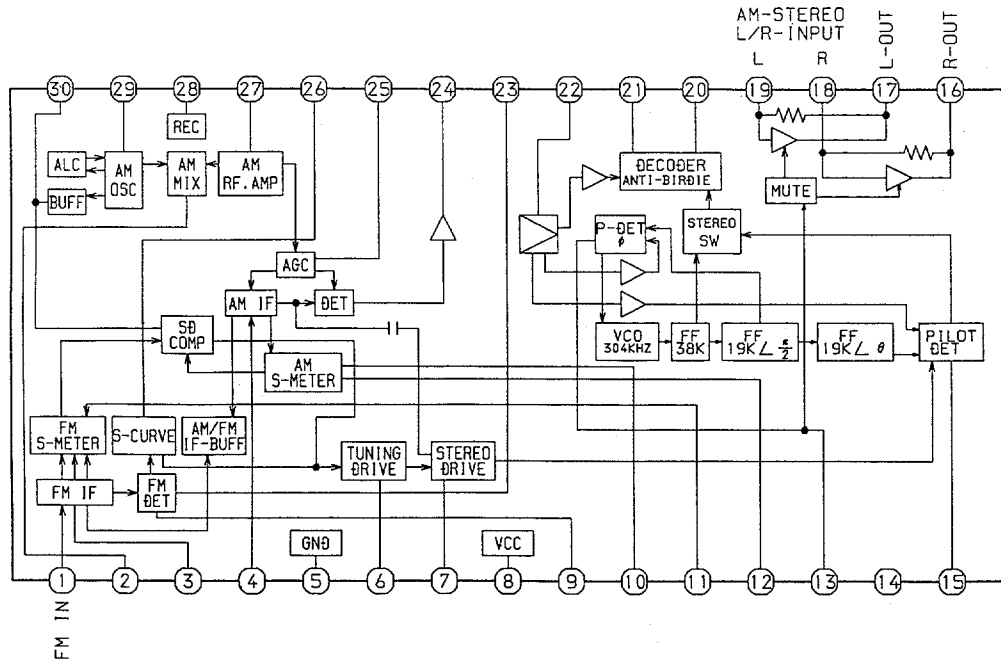

IC, M62439SP

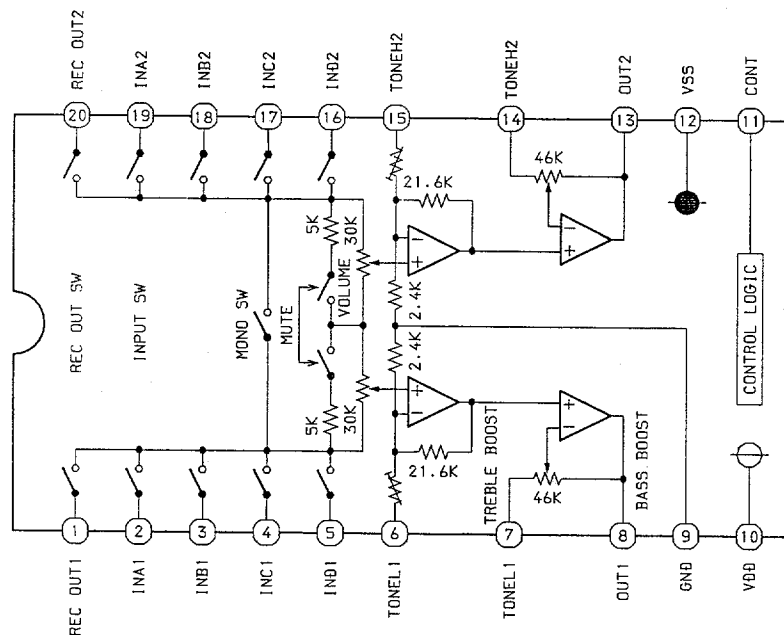

IC, BU1920FS <112 EZ>

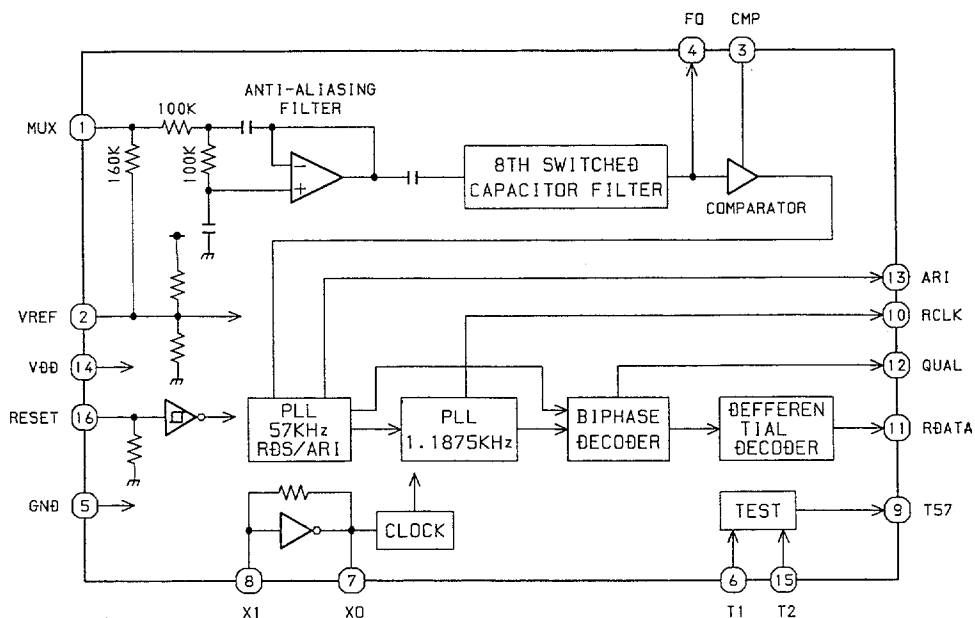

BLOCK DIAGRAM - 1 (TUNER : HR, HE, HC)

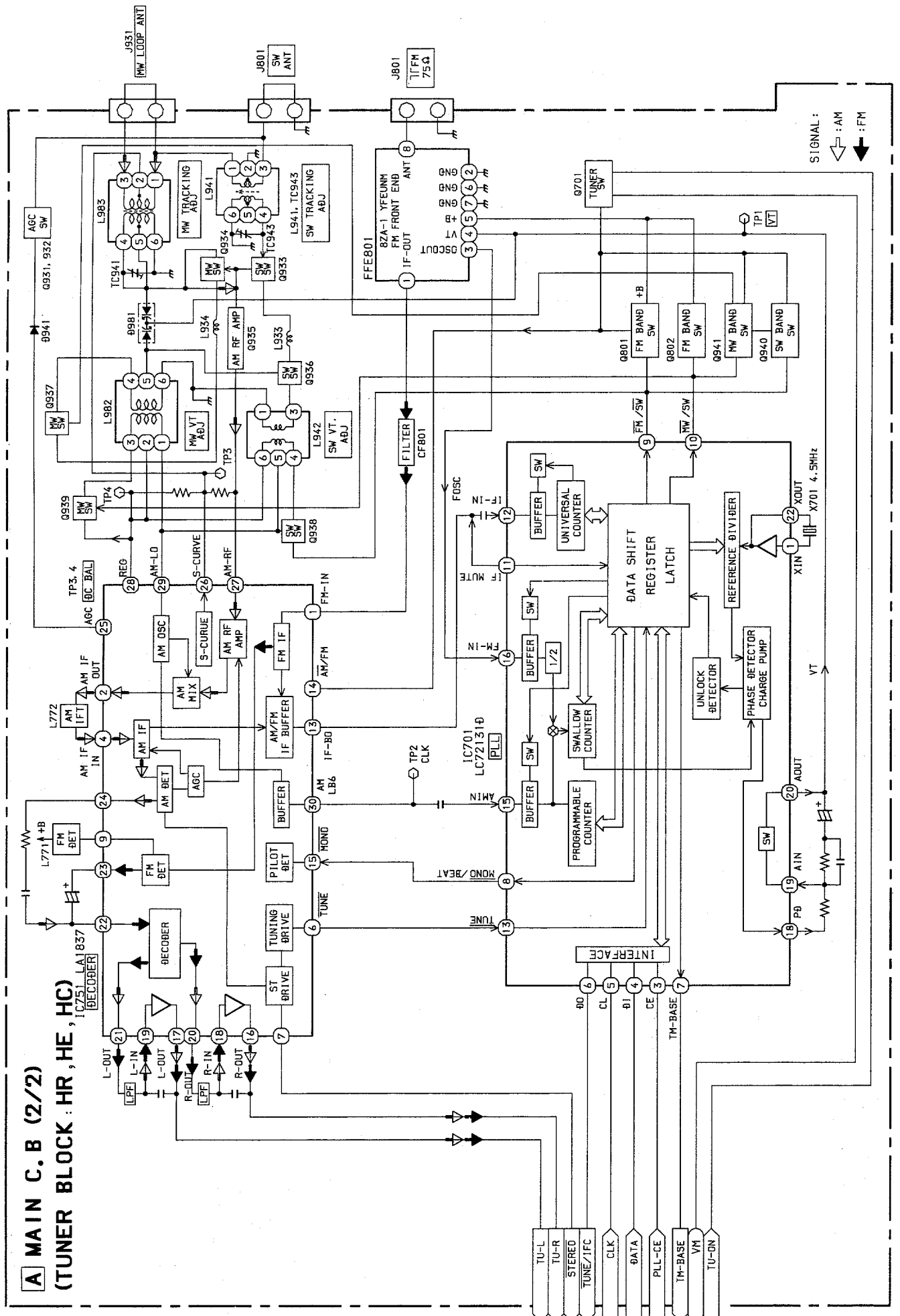

BLOCK DIAGRAM - 2 (TUNER : V)

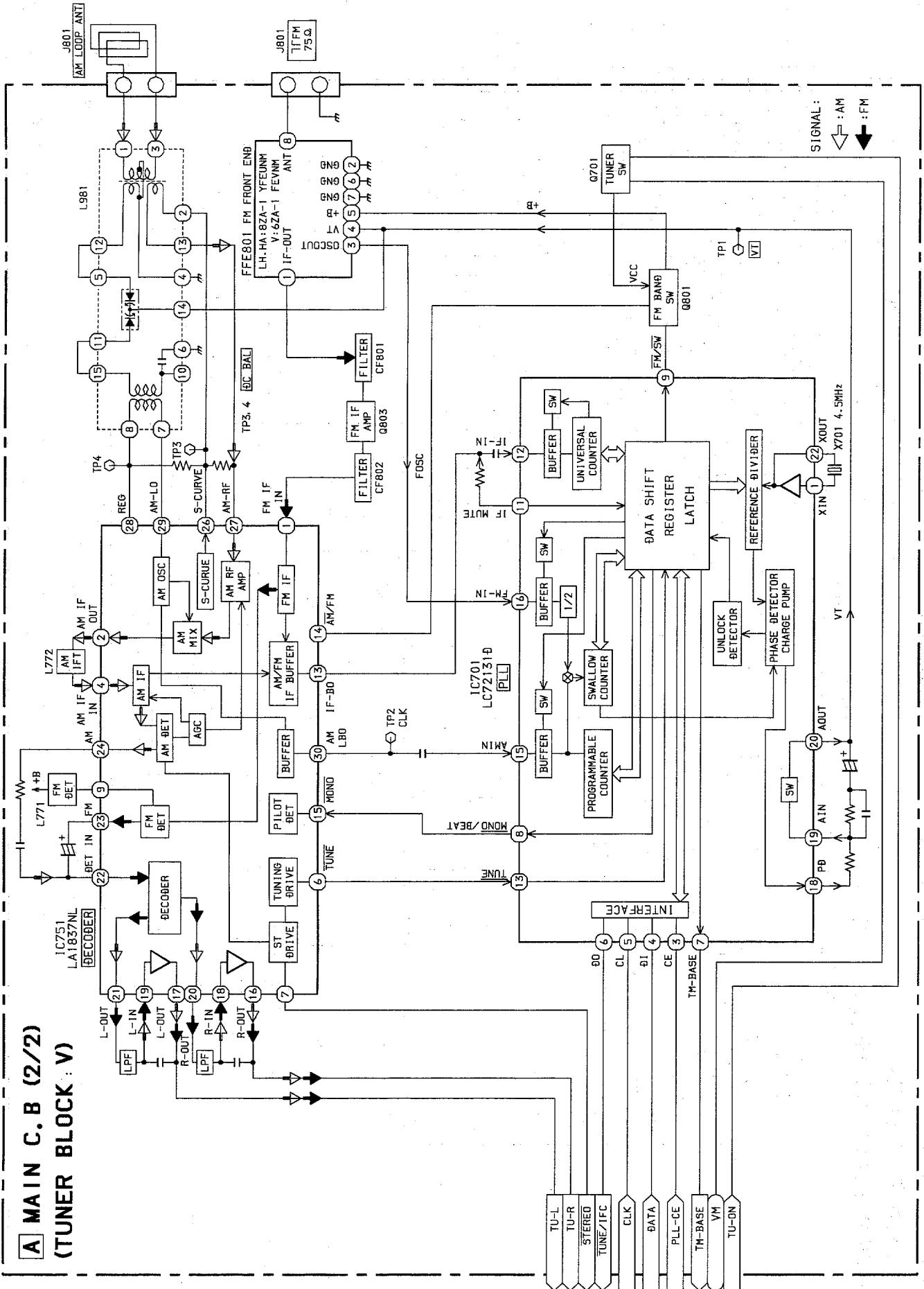

A MAIN C.B (2/2)
(TUNER BLOCK : V)

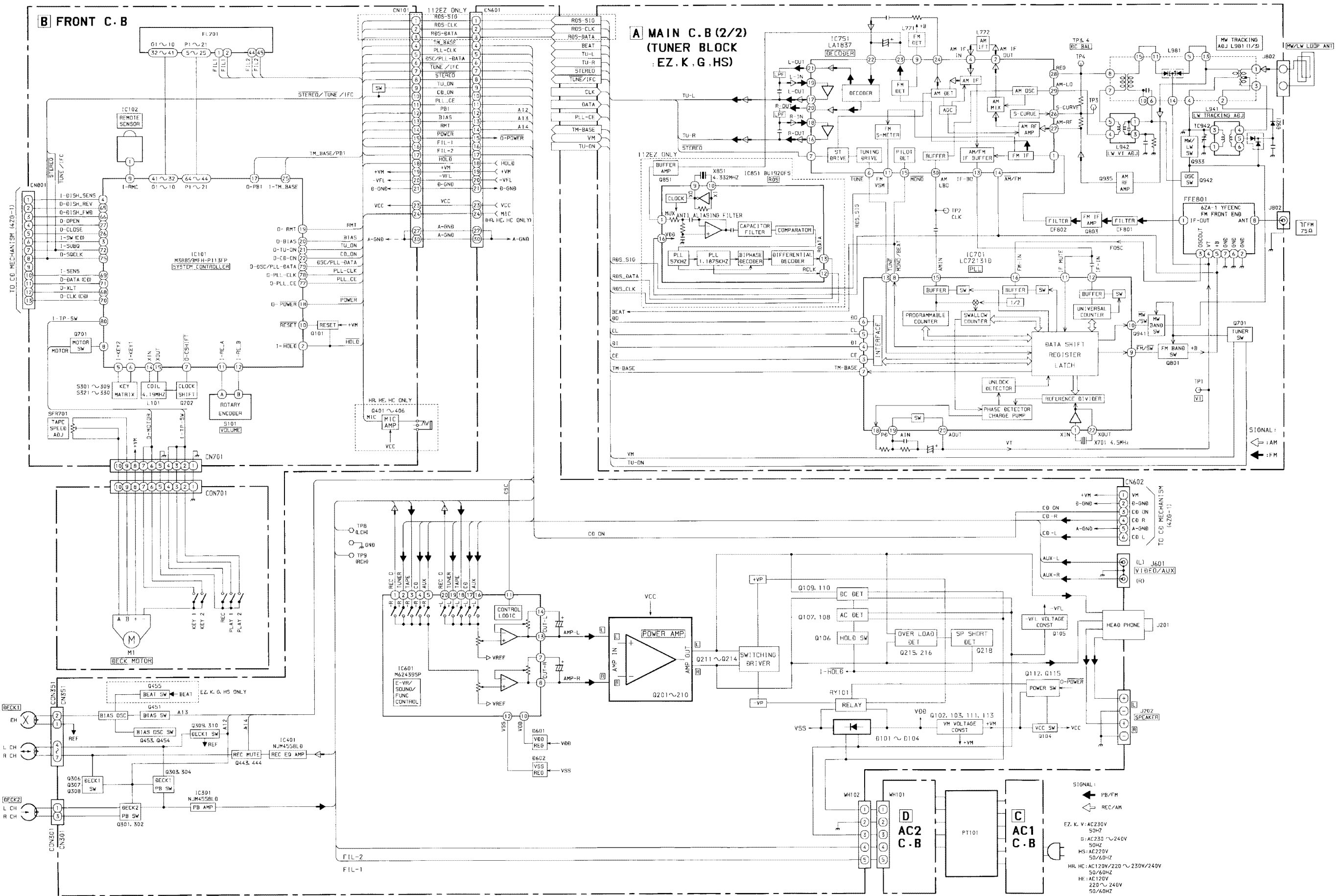

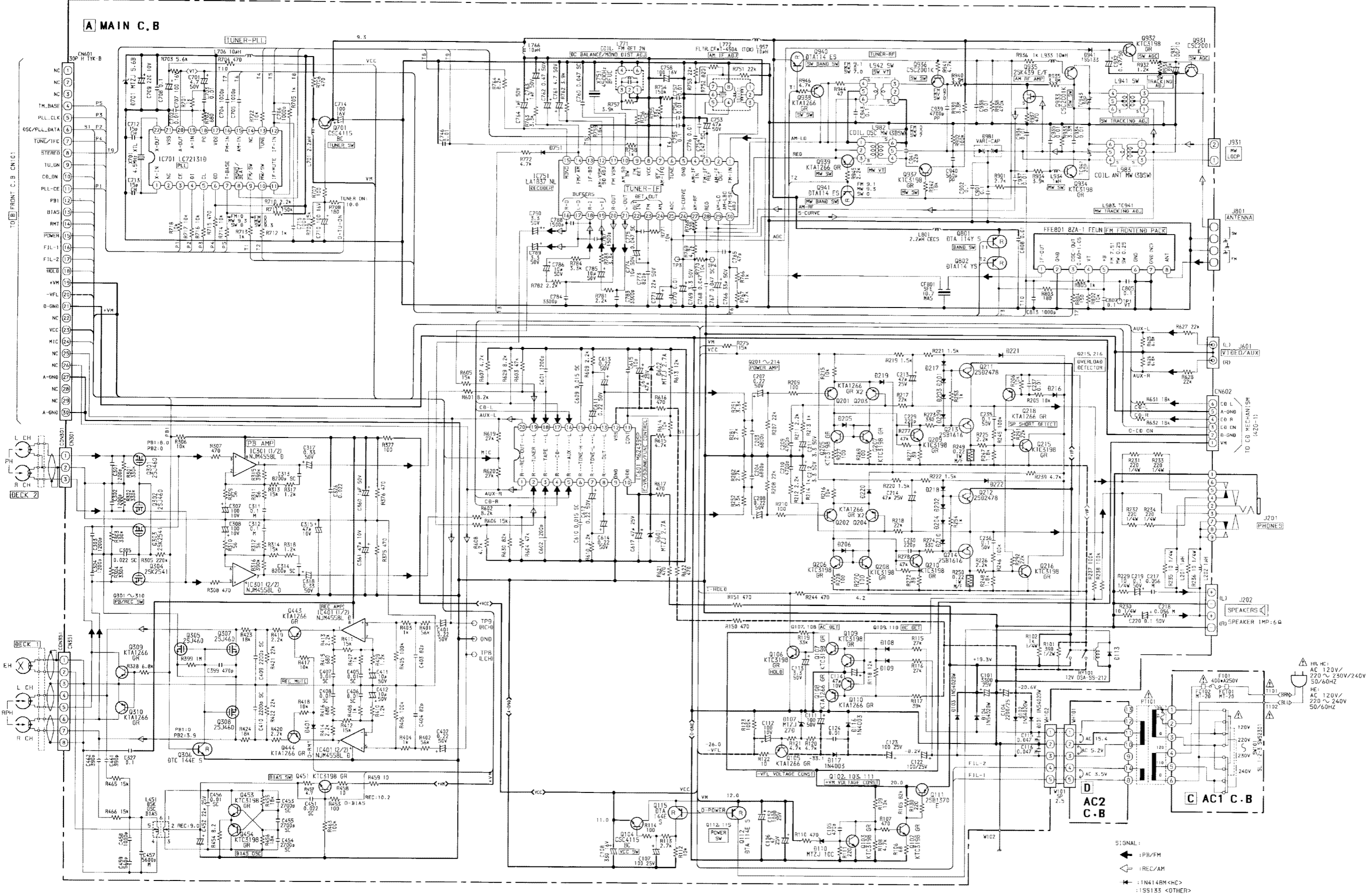

SIGNAL :
 ← : PB/FM
 ↕ : REC/AM
 ★ : IN4148M CHC
 ☆ : 1SS135 <OTHER>

A
B
C
D
E
F
G
H
I
J

A MAIN C.B

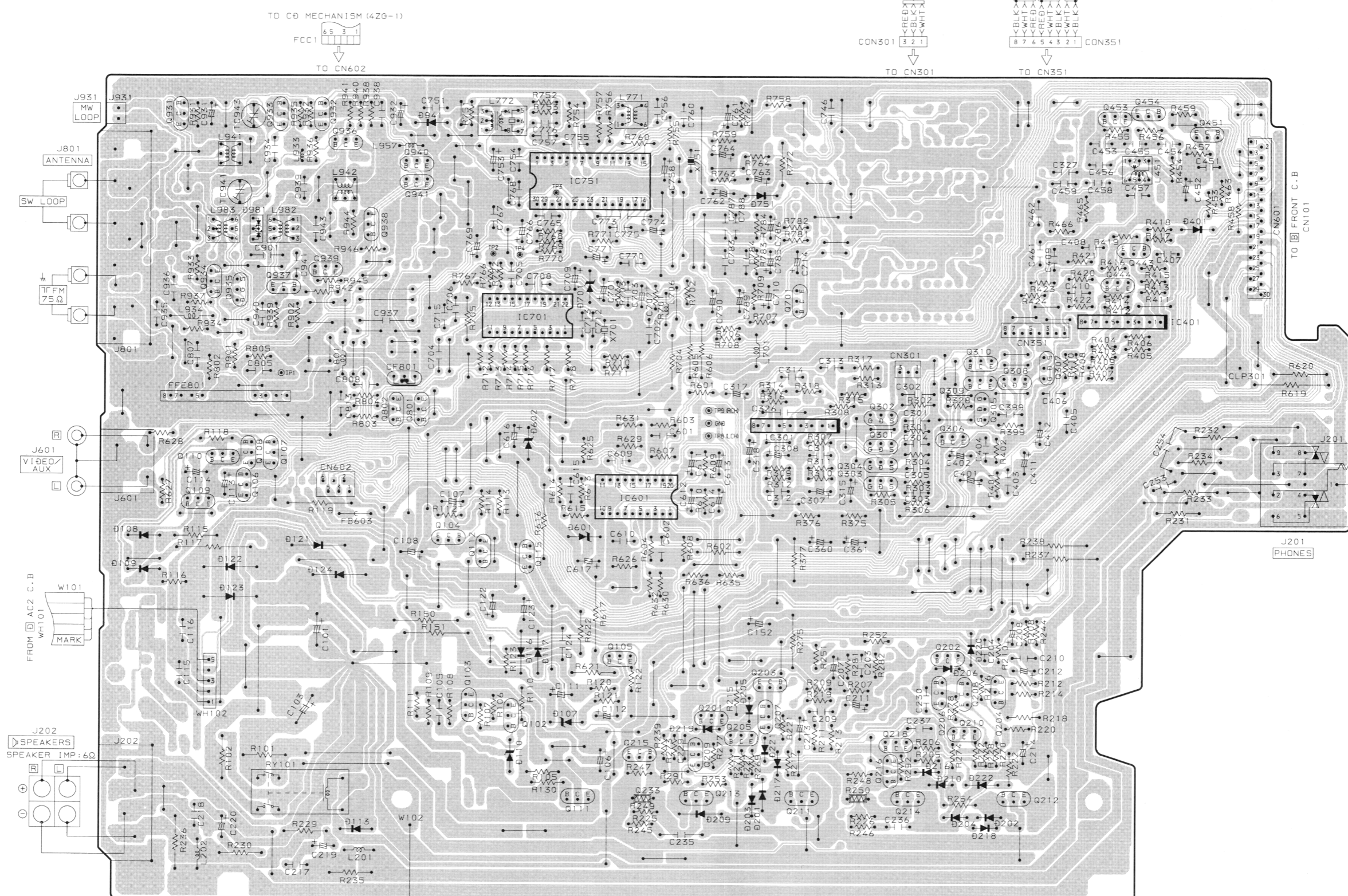

A MAIN C.B

TO C9 MECHANISM (4ZG-1)

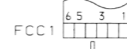

TO CN602

DECK2



TO CN301

DECK1

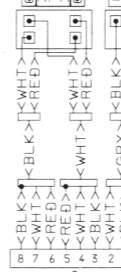

TO CN351

TO FRONT C.B
CN101

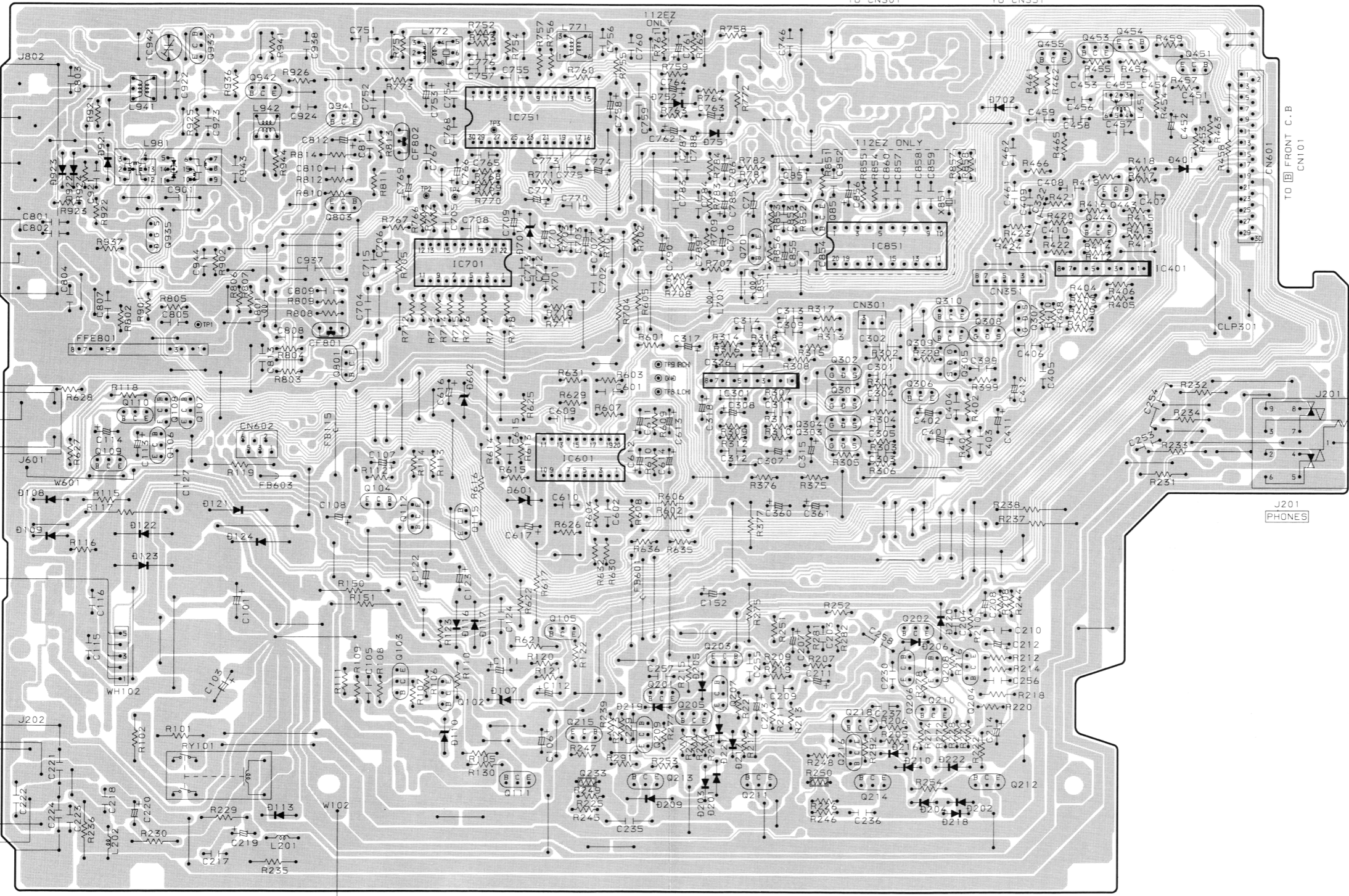

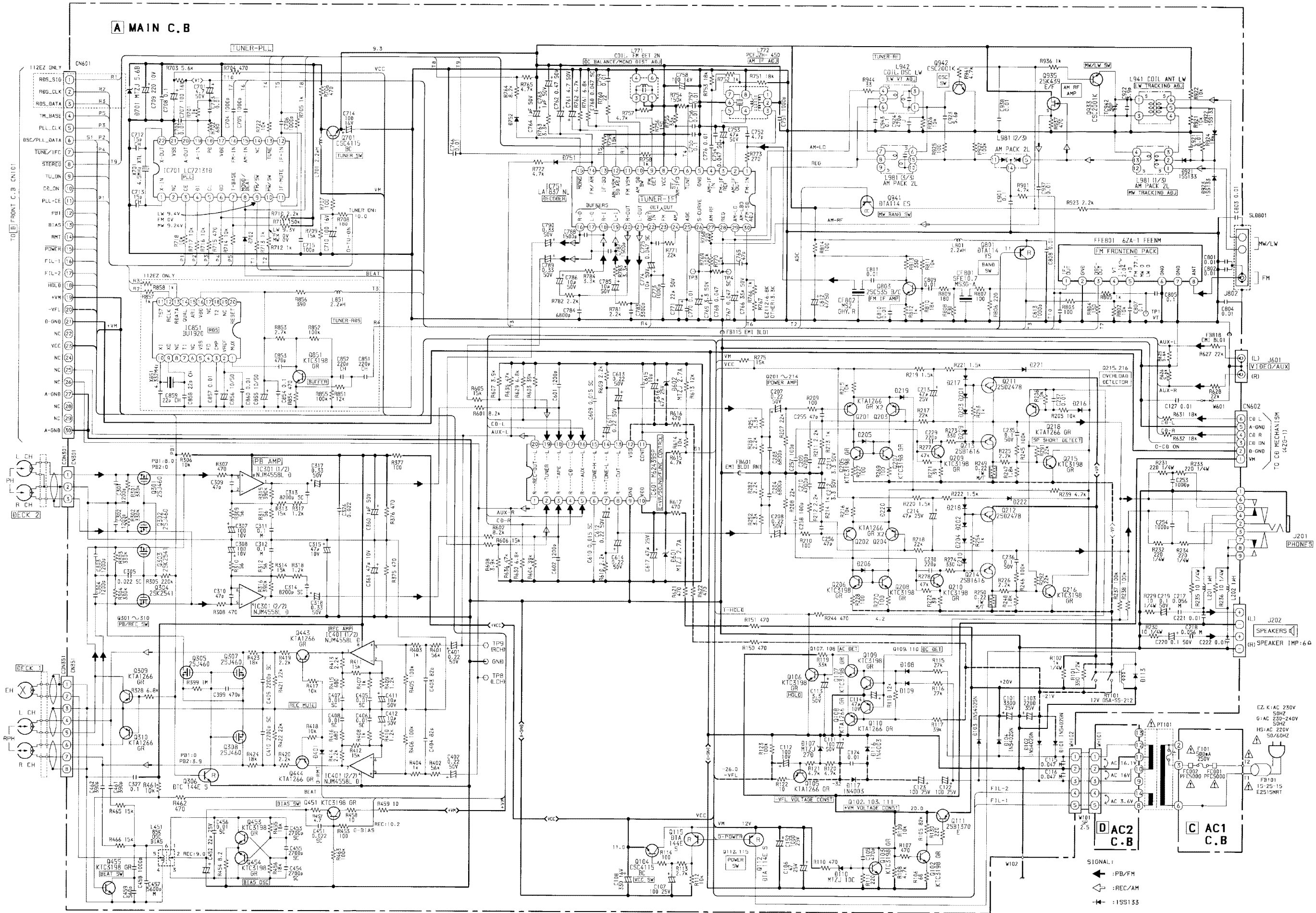

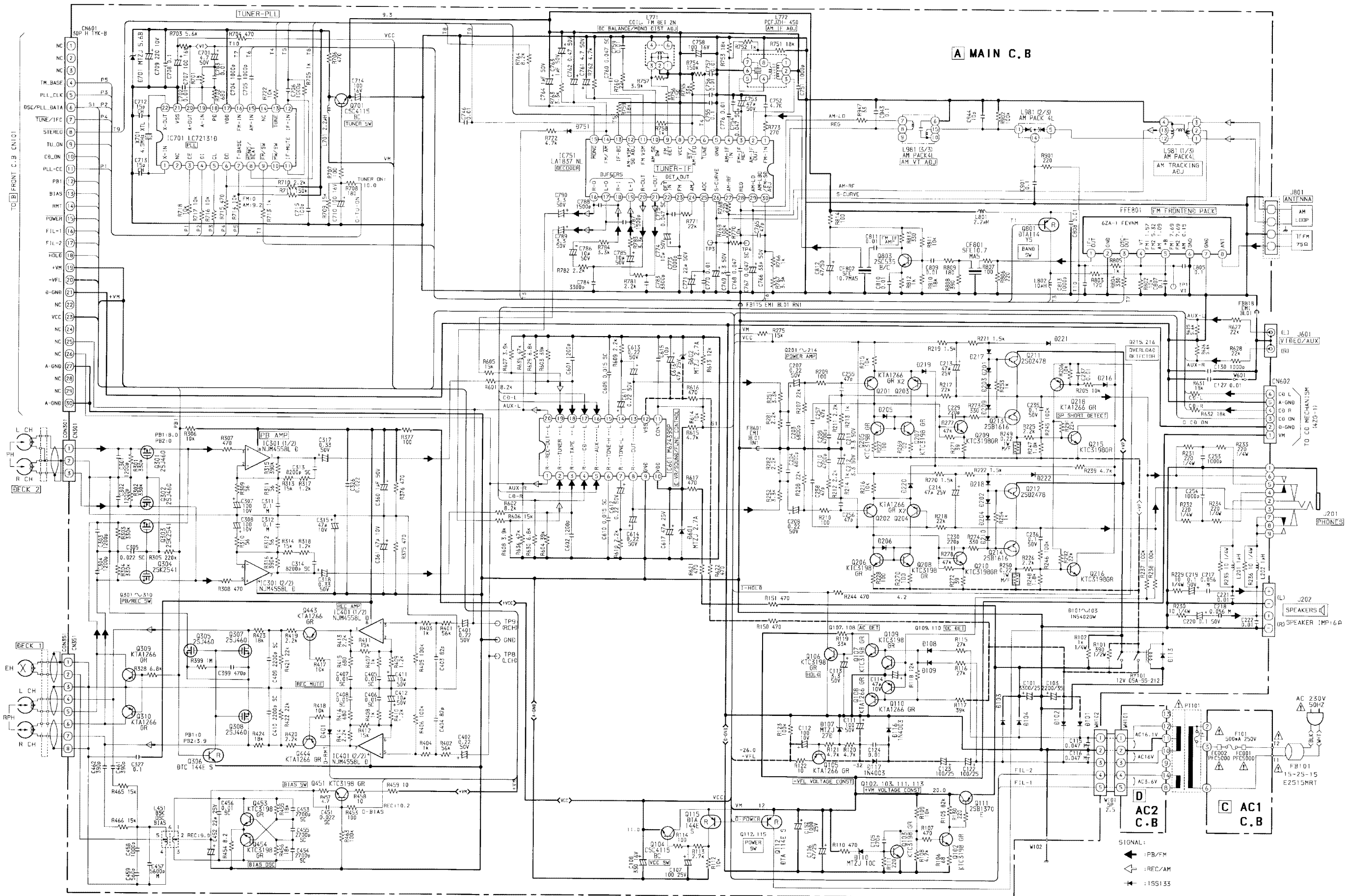

A
B
C
D
E
F
G
H
I
J

A MAIN C.B

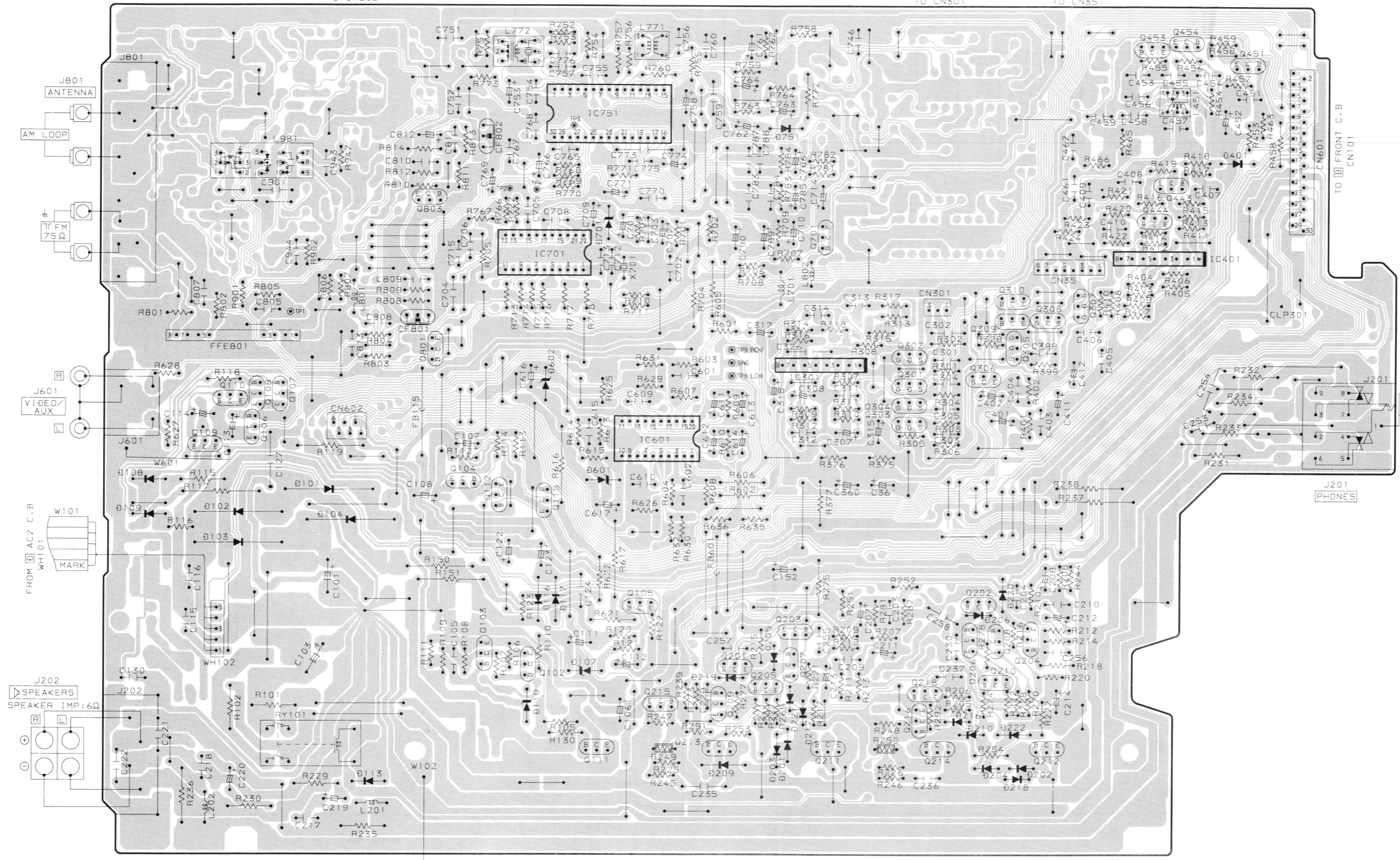
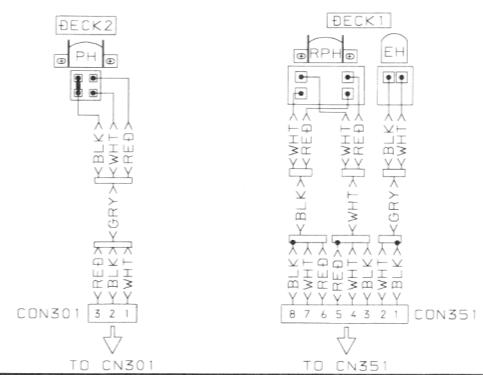
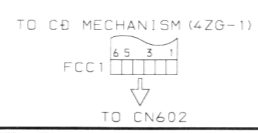

SCHEMATIC DIAGRAM - 4 (FRONT)

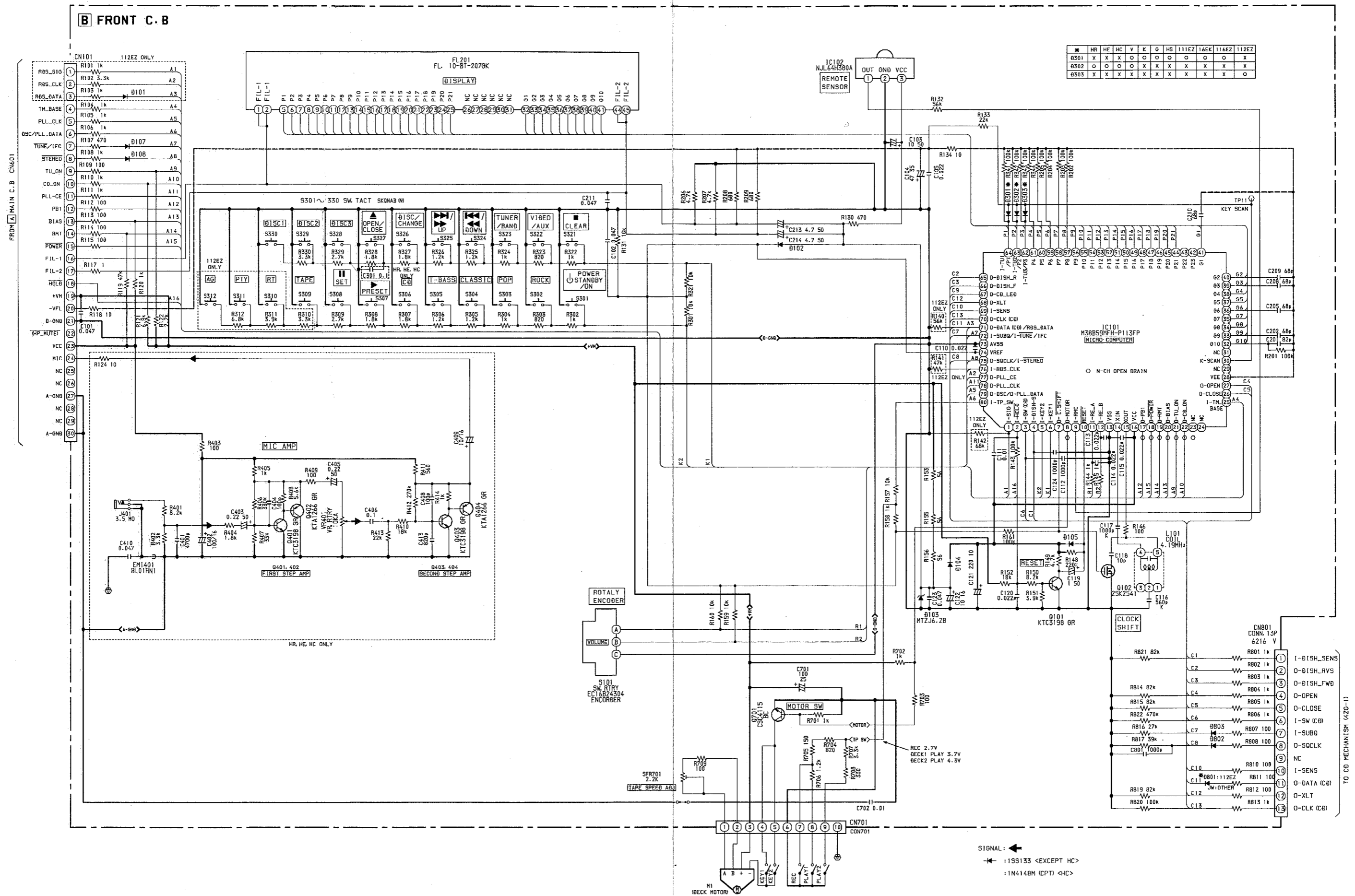

	HR	HE	HE	V	X	0	HS	112EZ	166K	116EZ	112EZ
* B501	X	X	X	X	X	X	X	X	X	X	X
B502	O	O	O	O	X	X	X	X	X	X	X
B503	X	X	X	X	X	X	X	X	X	X	O

Pin	Signal
1	I-TU
2	I-TU
3	I-TU
4	I-TU
5	I-TU
6	I-TU
7	I-TU
8	I-TU
9	I-TU
10	I-TU
11	I-TU
12	I-TU
13	I-TU
14	I-TU
15	I-TU
16	I-TU
17	I-TU
18	I-TU
19	I-TU
20	I-TU
21	I-TU
22	I-TU
23	I-TU
24	I-TU
25	I-TU
26	I-TU
27	I-TU
28	I-TU
29	I-TU
30	I-TU
31	I-TU
32	I-TU
33	I-TU
34	I-TU
35	I-TU
36	I-TU
37	I-TU
38	I-TU
39	I-TU
40	I-TU
41	I-TU
42	I-TU
43	I-TU
44	I-TU
45	I-TU
46	I-TU
47	I-TU
48	I-TU
49	I-TU
50	I-TU
51	I-TU
52	I-TU
53	I-TU
54	I-TU
55	I-TU
56	I-TU
57	I-TU
58	I-TU
59	I-TU
60	I-TU
61	I-TU
62	I-TU
63	I-TU
64	I-TU
65	I-TU
66	I-TU
67	I-TU
68	I-TU
69	I-TU
70	I-TU
71	I-TU
72	I-TU
73	I-TU
74	I-TU
75	I-TU
76	I-TU
77	I-TU
78	I-TU
79	I-TU
80	I-TU
81	I-TU
82	I-TU
83	I-TU
84	I-TU
85	I-TU
86	I-TU
87	I-TU
88	I-TU
89	I-TU
90	I-TU
91	I-TU
92	I-TU
93	I-TU
94	I-TU
95	I-TU
96	I-TU
97	I-TU
98	I-TU
99	I-TU
100	I-TU
101	I-TU
102	I-TU
103	I-TU
104	I-TU
105	I-TU
106	I-TU
107	I-TU
108	I-TU
109	I-TU
110	I-TU
111	I-TU
112	I-TU
113	I-TU
114	I-TU
115	I-TU
116	I-TU
117	I-TU
118	I-TU
119	I-TU
120	I-TU
121	I-TU
122	I-TU
123	I-TU
124	I-TU
125	I-TU
126	I-TU
127	I-TU
128	I-TU
129	I-TU
130	I-TU
131	I-TU
132	I-TU
133	I-TU
134	I-TU
135	I-TU
136	I-TU
137	I-TU
138	I-TU
139	I-TU
140	I-TU
141	I-TU
142	I-TU
143	I-TU
144	I-TU
145	I-TU
146	I-TU
147	I-TU
148	I-TU
149	I-TU
150	I-TU
151	I-TU
152	I-TU
153	I-TU
154	I-TU
155	I-TU
156	I-TU
157	I-TU
158	I-TU
159	I-TU
160	I-TU
161	I-TU
162	I-TU
163	I-TU
164	I-TU
165	I-TU
166	I-TU
167	I-TU
168	I-TU
169	I-TU
170	I-TU
171	I-TU
172	I-TU
173	I-TU
174	I-TU
175	I-TU
176	I-TU
177	I-TU
178	I-TU
179	I-TU
180	I-TU
181	I-TU
182	I-TU
183	I-TU
184	I-TU
185	I-TU
186	I-TU
187	I-TU
188	I-TU
189	I-TU
190	I-TU
191	I-TU
192	I-TU
193	I-TU
194	I-TU
195	I-TU
196	I-TU
197	I-TU
198	I-TU
199	I-TU
200	I-TU

SIGNAL: \leftarrow
 \leftarrow :1S5133 <EXCEPT HC>
 \leftarrow :1N4148M (CPT) <HC>

1 2 3 4 5 6 7 8 9 10 11 12 13 14

B FRONT C.B

A
B
C
D
E
F
G
H
I
J

TO CD MECHANISM
(4ZG-1)

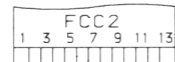

S101
VOLUME

FL201
(DISPLAY)

S306
CD

S322
VIDEO/AUX

S323
TUNER/BAND

S309
TAPE

S301
POWER
STANDBY/ON

IC102
(REMOTE SENSOR)

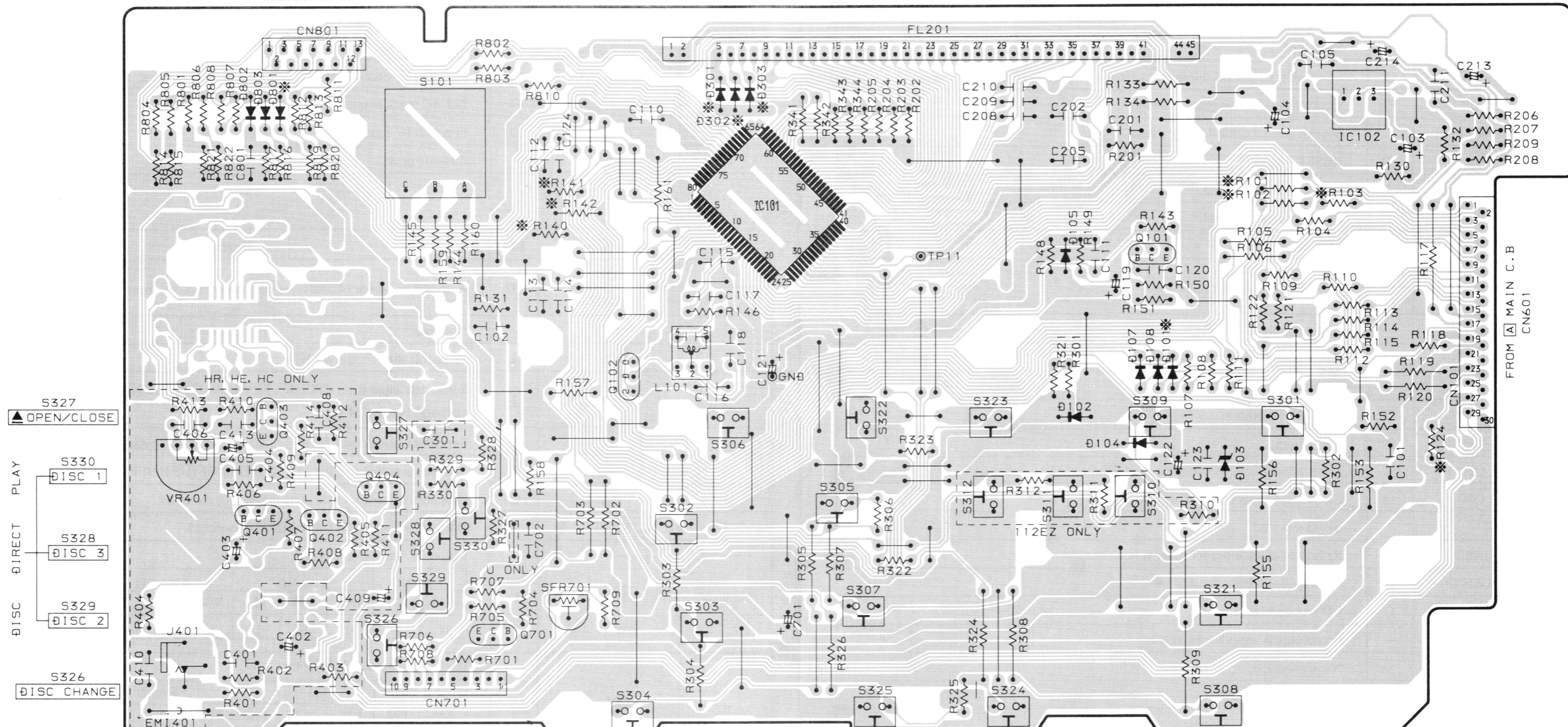

S327
▲ OPEN/CLOSE

S330
DISC 1

S328
DISC 3

S329
DISC 2

S326
DISC CHANGE

HR, HE, HC ONLY

KARAOKE
VR401
MIC MIXING
J401
MIC

TO CN701

CON701 (TAPE SPEED ADJ)
10 9 7 5 3 1

S304
CLASSIC

S302
ROCK

S305
T-BASS

S307
PRESET

S325
UP

S324
DOWN

S312 AG

S311 PTY

S310 RT

S321
CLEAR

S308
SET

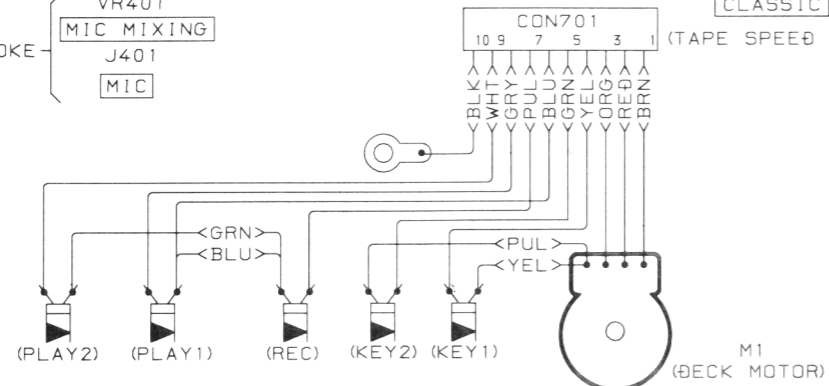

FROM MAIN C.B
CN601

	HR/HE/HC	V	K/G/HS/111EZ/16EZ/116EZ	112EZ
⊖101	X	X	X	0
⊖301	X	0	0	X
⊖302	0	0	X	X
⊖303	X	X	X	0
⊖801	X	X	X	0
R101	X	X	X	0
R102	X	X	X	0
R103	X	X	X	0
R124	0	X	X	X
R140	X	X	X	0
R141	X	X	X	0
R142	X	X	X	0

IC DESCRIPTION

IC, M38B59MFH-P113FP

Pin No.	Pin Name	I/O	Description
1	I-RDS_SIG	I	Tuner RDS signal input <112EZ>.
2	I-HOLD	I	Hold input.
3	I-SW(CD)	I	CD mechanical switch input.
4	I-DISH	I	CD turntable photo sensor input.
5	I-KEY2	I	KEY input 1.
6	I-KEY1	I	KEY input 2.
7	O-C.SHIFT	O	Clock shift output for microcomputer when tuner receiving broadcast.
8	O-MOTOR	O	Cassette deck motor control output.
9	I-RMC	I	System remote control signal input.
10	RESET	I	RESET input.
11	I-RE_A	I	Rotary encoder A input.
12	I-RE_B	I	Rotary encoder B input.
13	VSS	-	Connected to GND.
14	XIN	-	4.19 MHz oscillator circuit.
15	XOUT	-	
16	VCC	-	Power supply.
17	O-PB1	O	Cassette deck output switching.
18	O-POWER	O	Power control output.
19	O-RMT	O	REC MUTE output.
20	O-BIAS	O	Bias output.
21	O-TU_ON	O	Tuner power supply ON/OFF output.
22	O-CD_ON	O	CD power supply ON/OFF output.
23,24	NC	-	Not Connected.
25	I-TM_BASE	I	Reference clock input for timer watch.
26	O-CLOSE	O	CD tray close data output.
27	O-OPEN	O	CD tray open data output.
28	VEE	-	Power supply input for FL display.
29	NC	-	Not Connected.
30	K-SCAN	O	Initial scan output.
31	NC	-	Not connected.
32~41	G10~G1	O	FL grid output G1~G10.
42~43	P23~P24	O	FL segment output (Not connected).
44~62	P21~P3	O	FL segment output.
63	P2	I/O	FL segment output.
64	P1	O	FL segment output.
65	O-DISH_REV	O	CD turntable reverse rotation output.
66	O-DISH_FWR	O	CD turntable forward rotation output.
67	O-CD_LED	O	CD flash window output.(Not connected).
68	O-XLT	O	CD IC control output.
69	I-SENS	I	CD IC control output.
70	O-CLK(CD)	O	CD clock output.
71	O-DATA(CD)/RDS_DATA	O/I	CD data output / Tuner RDS data input <112EZ>.

Pin No.	Pin Name	I/O	Description
72	O-SUBQ/ I-TUNE/I-IFC	O/I	CD SUBQ data output/ TUNER signal input/ TUNER IF count serial data input.
73	AVSS	-	Connected to GND.
74	VREF	-	Power supply.
75	O-SQCLK/I-STEREO	O/I	CD SQCLK output/ TUNER STEREO detected input.
76	I-RDS_CLK	I	Tuner RDS clock input.<112EZ>.
77	O-PLL_CE	O	PLL IC chip enable output.
78	O-PLL_CLK	O	PLL IC clock output.
79	O-DSC/O-PLL DATA	O	Function IC control output / PLL data output.
80	I-TP_SW	I	Cassette deck.

IC, LC72131D

Pin No.	Pin Name	I/O	Description																								
1	XIN	I/O	A crystal oscillator (4.5MHz) is connected between these pins.																								
22	XOUT																										
2	NC	-	Not used.																								
3	CE	I	To enable the IC. Active "H".																								
4	DI	I	Serial data input from CPU (IC, M38B59MFH-P109FP) when relevant key is operated. Active "H".																								
5	CL	I	Synchronization clock for serial data in (DI) or serial data out (DO).																								
6	DO	O	Serial data output to CPU (IC, M38B59MFH-P109FP).																								
7	T-BASE	O	Outputs a reference clock signal (8Hz) for the clock.																								
8	MONO / BEAT	O	Outputs "H" when MONO / BEAT is switched.																								
9	FM / SW	O	Output "L" or "H" as follows: <table border="1" style="margin-left: 20px;"> <thead> <tr> <th colspan="2">2 BAND</th> <th colspan="3">3 BAND</th> <th colspan="3">3 BAND</th> </tr> <tr> <th>AM</th> <th>FM</th> <th>LW</th> <th>MW</th> <th>FM</th> <th>MW</th> <th>SW</th> <th>FM</th> </tr> </thead> <tbody> <tr> <td>H</td> <td>L</td> <td>H</td> <td>H</td> <td>L</td> <td>H</td> <td>L</td> <td>L</td> </tr> </tbody> </table>	2 BAND		3 BAND			3 BAND			AM	FM	LW	MW	FM	MW	SW	FM	H	L	H	H	L	H	L	L
2 BAND		3 BAND			3 BAND																						
AM	FM	LW	MW	FM	MW	SW	FM																				
H	L	H	H	L	H	L	L																				
10	MW/SW	O	Outputs "L" or "H" as follows: <table border="1" style="margin-left: 20px;"> <thead> <tr> <th colspan="2">2 BAND</th> <th colspan="3">3 BAND</th> <th colspan="3">3 BAND</th> </tr> <tr> <th>AM</th> <th>FM</th> <th>LW</th> <th>MW</th> <th>FM</th> <th>MW</th> <th>SW</th> <th>FM</th> </tr> </thead> <tbody> <tr> <td>L</td> <td>L</td> <td>H</td> <td>L</td> <td>L</td> <td>L</td> <td>H</td> <td>L</td> </tr> </tbody> </table>	2 BAND		3 BAND			3 BAND			AM	FM	LW	MW	FM	MW	SW	FM	L	L	H	L	L	L	H	L
2 BAND		3 BAND			3 BAND																						
AM	FM	LW	MW	FM	MW	SW	FM																				
L	L	H	L	L	L	H	L																				
11	IF-MUTE	O	To control internal counter.																								
12	IF-IN	I	General purpose counter input.																								
13	TUNE	I	Receives "L" when station is tuned.																								
14	NC	-	Not connected.																								
15	AM-IN	I	Receives the AM local oscillator frequency signal.																								
16	FM-IN	I	Receives the FM local oscillator frequency signal.																								
17	VDD	-	Supply power to IC (+5V).																								
18	PD	O	PLL charge pump output.																								
19	A-IN	I	The MOS transistor for PLL active low pass filter.																								
20	A-OUT	O																									
21	VSS	-	Ground.																								

WIRING - 5 (POWER)

1 2 3 4 5 6 7

A
B
C
D
E
F
G
H
I
J

C AC1 C.B

D AC2 C.B

EZ, K, V:
AC 230V
50Hz
G:
AC 230~240V
50Hz
HS:
220V
50/60Hz

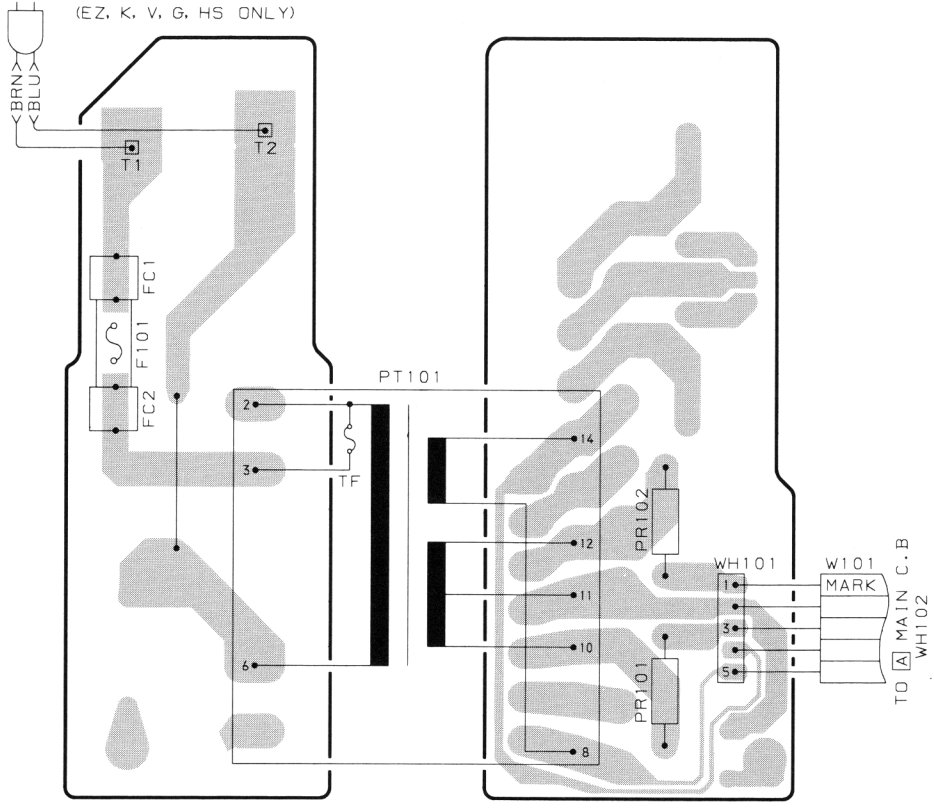

HR, HC:
AC 120V/
220~230V
240V
50/60Hz
HE:
AC 120V
220~240V
50/60Hz

C AC1 C.B

(HR, HE, HC ONLY)

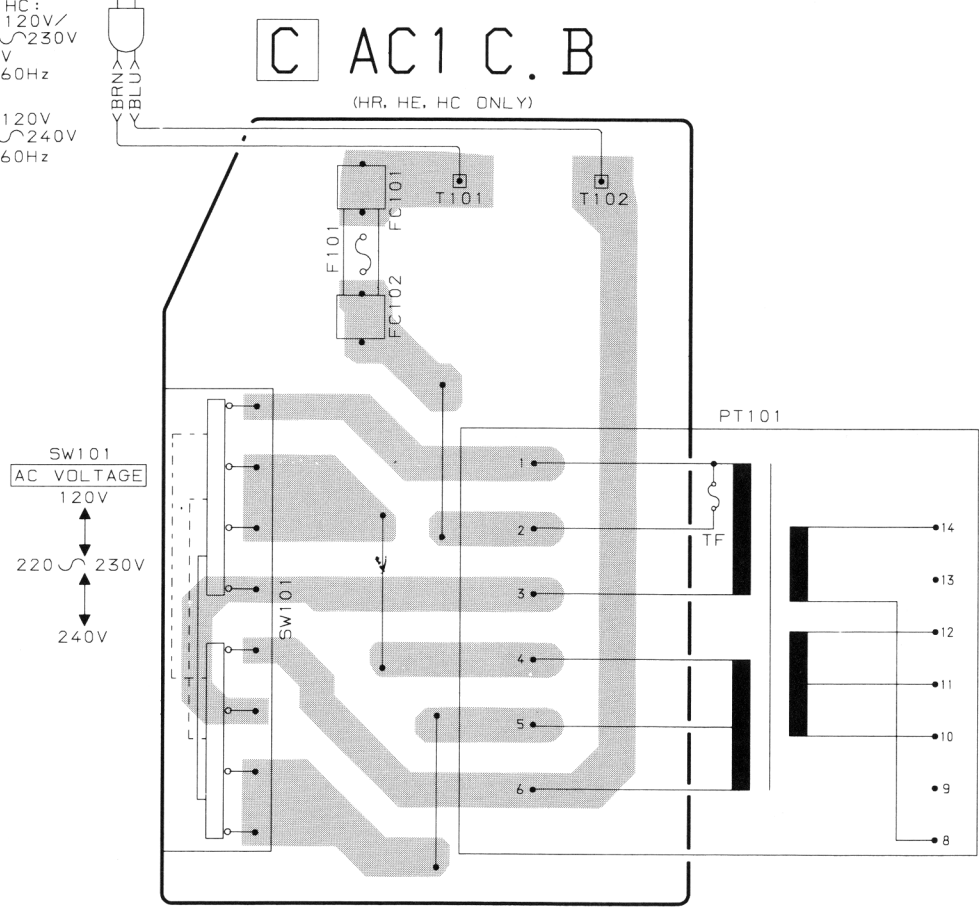

FL GRID ASSIGNMENT & ANODE CONNECTION

GRID ASSIGNMENT

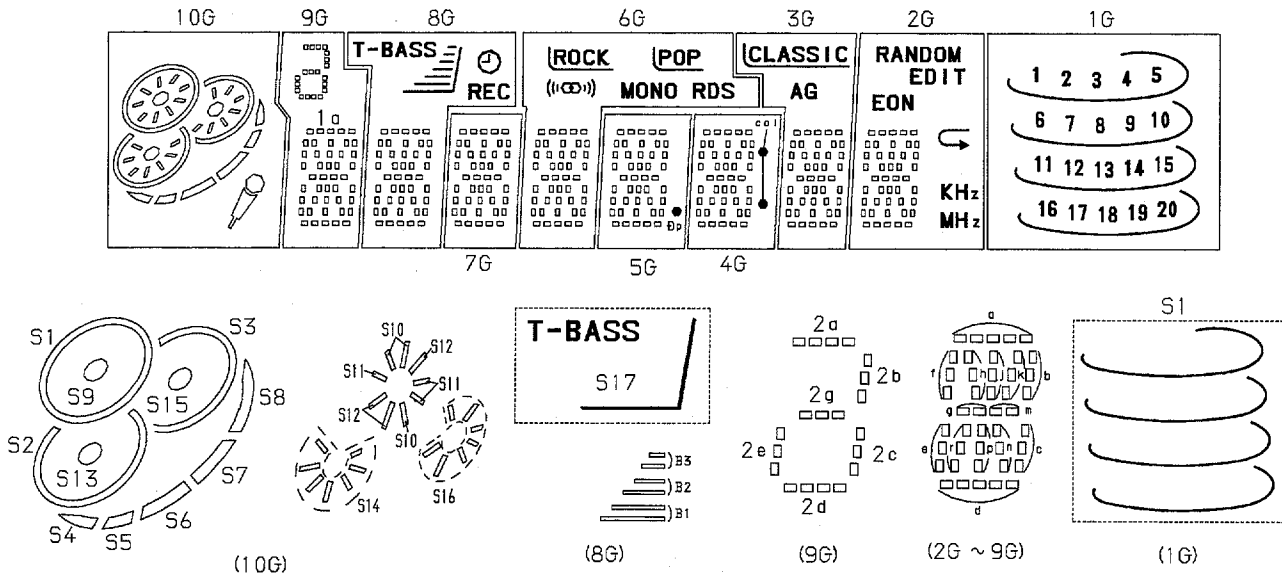

ANODE CONNECTION

	10G	9G	8G	7G	6G	5G	4G	3G	2G	1G
P1	S6	1d	d	d	d	d	d	d	d	20
P2	S7	1n	n	n	n	n	n	n	n	19
P3	S8	1p	p	p	p	p	p	p	p	18
P4	S14	1r	r	r	r	r	r	r	r	17
P5	S13	1e	e	e	e	e	e	e	e	16
P6	S2	1c	c	c	c	c	c	c	c	15
P7	S16	1g	g	g	g	g	g	g	g	14
P8	S15	1m	m	m	m	m	m	m	m	13
P9	S3	1f	f	f	f	f	f	f	f	12
P10	S12	1b	b	b	b	b	b	b	b	11
P11	S11	1k	k	k	k	k	k	k	k	10
P12	S10	1j	j	j	j	j	j	j	j	9
P13	S9	1h	h	h	h	h	h	h	h	8
P14	S1	1a	a	a	a	a	a	a	a	7
P15	S5	/	REC	/	((CD))	⊕p	col (F)	/	MHz	6
P16	S4	/	⊕	/	MONO	/	col (L)	/	KHz	5
P17	🔊	2a, 2g, 2d	S17	/	RDS	/	/	AG	↻	4
P18	/	2e	B1	/	(ROCK)	/	/	(CLASSIC)	EON	3
P19	/	2c	B2	/	(POP)	/	/	/	EDIT	2
P20	/	2b	B3	/	ROCK/POP	/	/	CLASSIC	RANDOM	1
P21	/	/	/	/	/	/	/	/	/	S1

ADJUSTMENT <TUNER / DECK>

A MAIN C.B

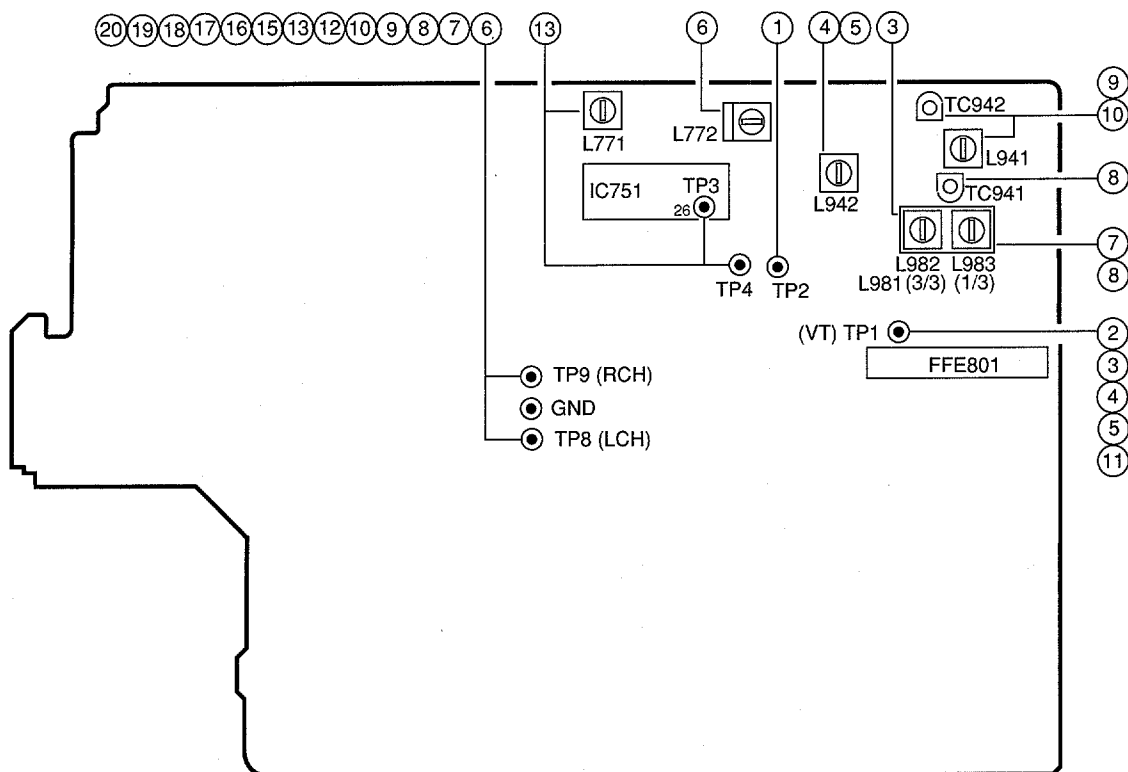

B FRONT C.B

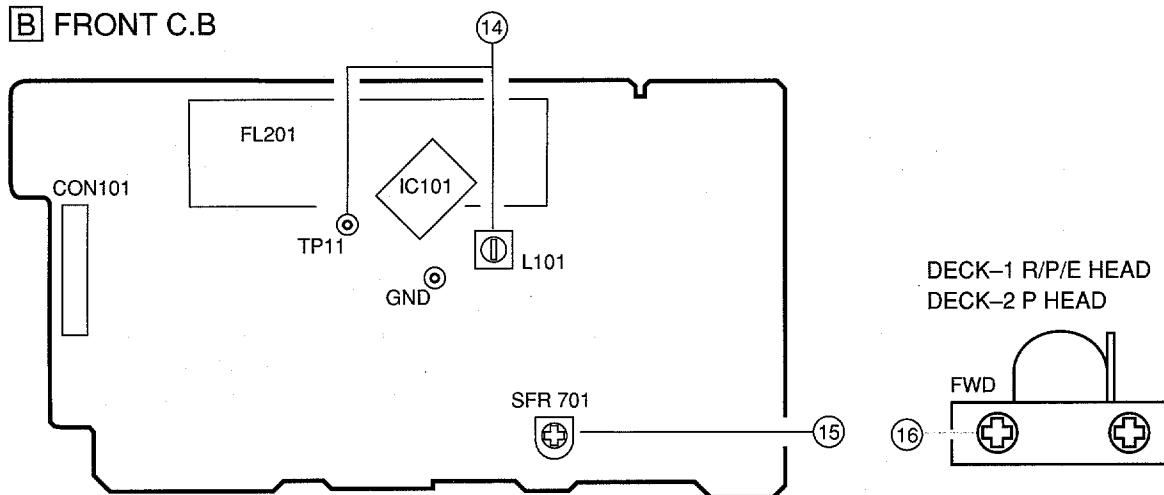

< TUNER SECTION >

1. Clock Frequency Check
Settings : • Test point : TP2
Method : Set to AM 1602kHz and check that the test point is 2052kHz \pm 45Hz.
2. AM/MW VT Check <EZ,K,V,G,HS>
Settings : • Test point : TP1
Method : Set to AM 1602kHz and AM 531kHz and check that the test point is less than 8.0V(1602kHz) and more than 0.6V(531kHz).
3. MW VT Adjustment <HR,HE,HC>
Settings : • Test point : TP1 (VT)
• Adjustment location : L982
Method : Set to MW 1710kHz and adjust L982 so that the test point becomes 8.0V \pm 0.05V. Then check that the test point is more than 0.3V (530kHz).
4. SW VT Adjustment <HR,HE,HC>
Settings : • Test point : TP1 (VT)
• Adjustment location : L942
Method : Set to SW 17.9MHz and adjust L942 so that the test point becomes 7.0V \pm 0.05V. Then check that the test point is more than 0.3V (5.9MHz).
5. LW VT Adjustment <EZ,K,G,HS>
Settings : • Test point : TP1 (VT)
• Adjustment location : L942
Method : Set to LW 144kHz and adjust L942 so that the test point is 1.3V \pm 0.05V. Then check that the test point is less than 8.0V (290kHz).
6. AM /MW IF Adjustment
Settings : • Test point : TP8(Lch), TP9(Rch)
• Adjustment location : L772.....450kHz

Method : The output level at 999/1000kHz is adjusted to maximum by L772.

< DECK SECTION >

7. MW Tracking Adjustment <EZ,K,G,V,HS>

Settings : • Test point : TP8(Lch), TP9(Rch)
• Adjustment location : L981(1/3).....999/1000kHz

Method : The output level at 999/1000kHz is adjusted to maximum by L981(1/3).

15. Tape Speed Adjustment

Settings : • Test tape : TTA-100
• Test point : TP8(Lch), TP9(Rch)
• Adjustment location : SFR701

Method : Play back the test tape and adjust SFR701 so that the frequency counter reads 3000Hz \pm 5Hz.

8. MW Tracking Adjustment <HR,HE,HC>

Settings : • Test point : TP8(Lch), TP9(Rch)
• Adjustment location : L983603kHz
TC9411404kHz

Method : Set up TC941 to center before adjustment. The output level at 603kHz is adjusted to maximum by L983. Then the output level at 1404kHz is adjusted to maximum by TC941.

16. Head Azimuth Adjustment (DECK 1, DECK 2)

Settings : • Test tape : TTA-330
• Test point : TP8(Lch), TP9(Rch)
• Adjustment location : Azimuth adjustment screw

Method : Play back the 8kHz signal of the test tape and adjust screw so that the output becomes maximum. Perform on FWD PLAY and REV PLAY mode.

9. LW Tracking Adjustment <EZ,K,G,HS>

Settings : • Test point : TP8(Lch), TP9(Rch)
• Adjustment location : L941144MHz
TC942290MHz

Method : Set up TC942 to center before adjustment. The output level at 144kHz is adjusted to maximum by L941. Then the level at 290kHz is adjusted to maximum by TC942.

17. PB Frequency Response Check (DECK 1, DECK 2)

Settings : • Test tape : TTA-330
• Test point : TP8(Lch), TP9(Rch)

Method : Play back the 315Hz and 8kHz signals of the test tape and check that the output ratio of the 8kHz signal with respect to that of the 315Hz signal is within 5dB.

10. SW Tracking Adjustment <HR,HE,HC>

Settings : • Test point : TP8(Lch), TP9(Rch)
• Adjustment location : L9415.9MHz
TC94217.9MHz

Method : Set up TC942 to center before adjustment. The output level at 5.9MHz is adjusted to maximum by L941. Then the output level at 17.9MHz is adjusted to maximum by TC942.

18. PB Sensitivity Check (DECK 1, DECK 2)

Settings : • Test tape : TTA-200
• Test point : TP8(Lch), TP9(Rch)

Method : Play back the test tape and check the signal level of the test point is 110mV \pm 3.0dB.

11. FM VT Check

Settings : • Test point : TP1
Method : <HR,HE,HC,EZ,K,G,HS>

Set to FM 108.0MHz and check that the test point is less than 8.0V. Set to FM 87.5MHz and check that the test point is more than 0.5V.

<V>

Set to FM 108.0MHz and check that the test point is less than 9.5V. Set to FM 65.0MHz and check that the test point is more than 1.0V.

19. REC/PB Frequency Response Check

Settings : • Test tape : TTA-602
• Test point : TP8(Lch), TP9(Rch)
• Input signal : 1kHz / 8kHz, -26dBV (LINE IN)

Method : Apply 1kHz signal and REC mode. Then adjust OSC attenuator so that the output level at the TP8, TP9 becomes 8~10mV. Record and play back the 1kHz and 8kHz signals and check that the output is 0dB \pm 5dB with respect to that of the 1kHz signal.

12. FM Tracking Check

Settings : • Test point : TP8(Lch), TP9(Rch)
Method : Set to FM 98.0MHz and check that the test point is less than 9.0dB μ V <HR,HE,HC> / 13.0dB μ V <EZ,K,G,HS> / 8.0dB μ V <V>.

20. REC/PB Sensitivity Check

Settings : • Test tape : TTA-602
• Test point : TP8(Lch), TP9(Rch)
• Input signal : 1kHz, -6dBV (LINE IN)

Method : Apply 1kHz signal and REC mode. Then adjust OSC attenuator so that the output level at the TP8, TP9 becomes 80~100mV. Record and play back the 1kHz signals and check that the output is -2.0dB \pm 3.5dB.

13. DC Balance / Mono Distortion Adjustment

Settings : • Test point : TP3,TP4 / TP8,TP9
• Adjustment location : L77198.0MHz
• Input level : 60 dB μ V

Method : Set to FM 98.0MHz and adjust L771 so that the voltage between TP3 and TP4 becomes 0V \pm 0.04V. Next, check that the distortion is less than 1.3%.

14. μ -con OSC Adjustment

Settings : • Test point : TP11
• Adjustment location : L101
Method : Insert AC plug with pressing TUNER function key. Adjust L101 so that the frequency across the test point is 58.538 ~ 58.422Hz.

PRACTICAL SERVICE FIGURE

<TUNER SECTION>

<FM SECTION>

IHF Sensitivity :	HR,HE,HC :
(THD 3%)	Less than 10dB μ V[at 87.5MHz]
	Less than 9dB[at 98.0/108.0MHz]
	V :
	Less than 12dB[at 70.0MHz]
	Less than 10dB μ V[at 87.5MHz]
	Less than 9dB[at 98.0/108.0MHz]
	EZ,K,G,HS :
	Less than 14dB μ V[at 87.5MHz]
	Less than 13dB[at 98.0/108.0MHz]
S/N 50dB Quieting sensitivity :	
(Stereo)	HR,HE,HC, V :
	Less than 35dB[at 98.0MHz]
	EZ,K,G,HS :
	Less than 38dB[at 98.0MHz]
Signal to noise ratio :	More than 68dB (mono)[at 98.0MHz]
	HR,HE,HC, V :
	More than 66dB (stereo)[at 98.0MHz]
	EZ,K,G,HS :
	More than 66dB (stereo)[at 98.0MHz]
Distortion :	Less than 1.2% (mono)[at 83.0MHz/98.0MHz]
	Less than 2.0% (stereo)[at 98.0MHz]
Stereo separation :	HR,HE,HC,EZ,K,G,HS :
	More than 12dB[at 98.0MHz]
	V :
	More than 22dB[at 98.0MHz]

<AM/MW SECTION>

Sensitivity :	Less than 60dB μ V [at 600/603kHz]
(S/N 20 dB)	Less than 58dB μ V
	[at 999/1000/1400/1404kHz]
Signal to noise ratio :	More than 36dB(mono)[at 999/1000kHz]
Distortion :	Less than 1.5% (mono)[at 999/1000kHz]

<SW SECTION> (HR,HE,HC)

Sensitivity :	Less than 51dB μ V [at 5.9MHz]
	Less than 45dB μ V [at 12.0 MHz]
	Less than 44dB μ V [at 17.9MHz]
Distortion :	Less than 10% [at 12.0MHz]

<LW SECTION> (EZ,K,G)

Sensitivity :	Less than 70dB [at 144kHz]
	Less than 68dB [at 198kHz]
	Less than 66dB [at 290kHz]

<DECK SECTION>

Tape speed :	3000Hz \pm 45Hz
Wow & flutter :	Less than 0.35% (R.M.S)
Take-up torque :	30 ~ 60g/cm (FWD)
Back tension :	2 ~ 5g/cm
PB Output level :	2.8V \pm 3dB
Distortion (REC/PB) :	Less than 2.0% (NORM)
Noise level (PB) :	Less than 40mV (NORM)
Noise level (REC/PB) :	Less than 40mV(NORM)
Erasing ratio:	More than 60dB (at 125Hz,+10VU)

TAPE MECHANISM EXPLODED VIEW 1/1

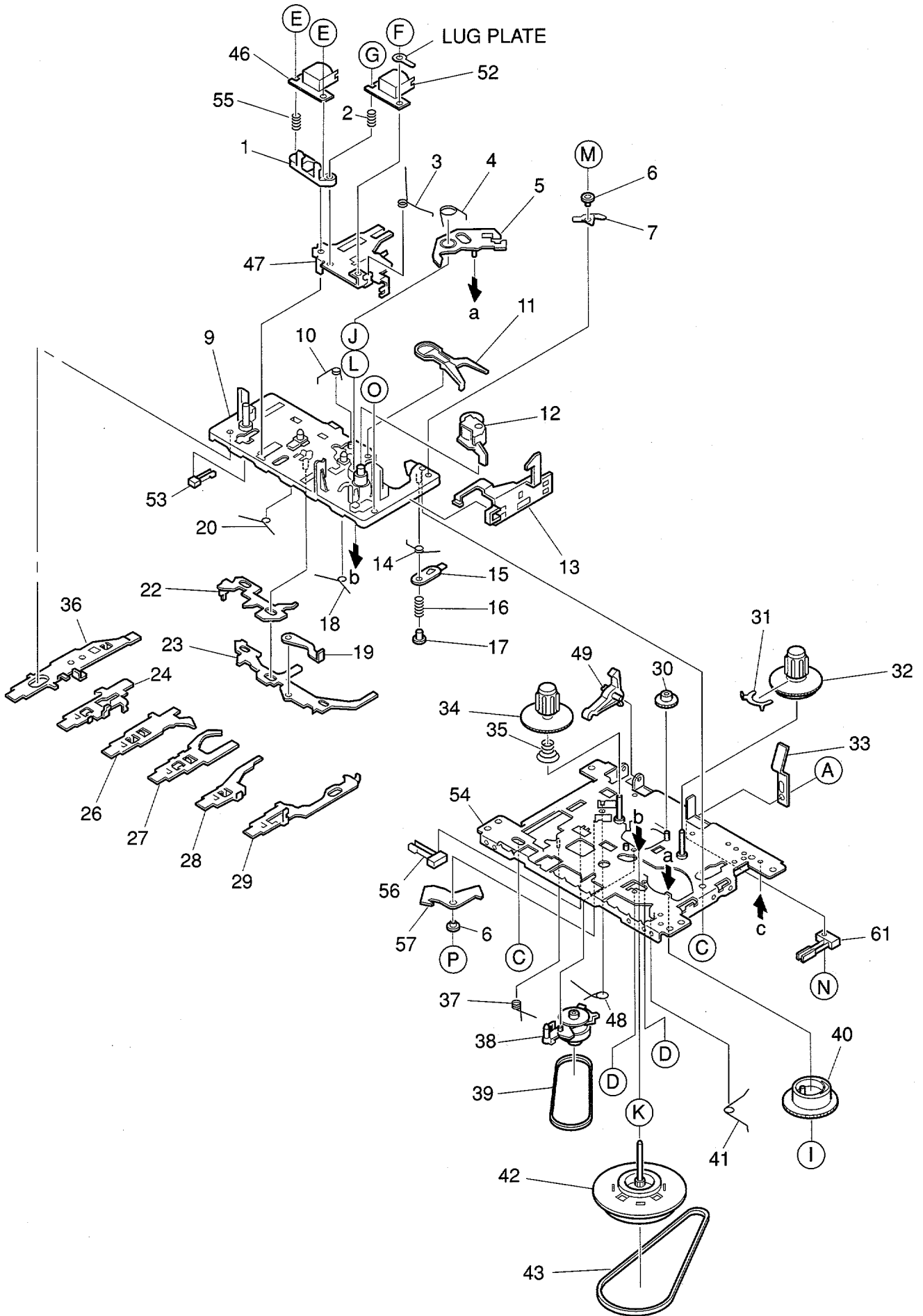

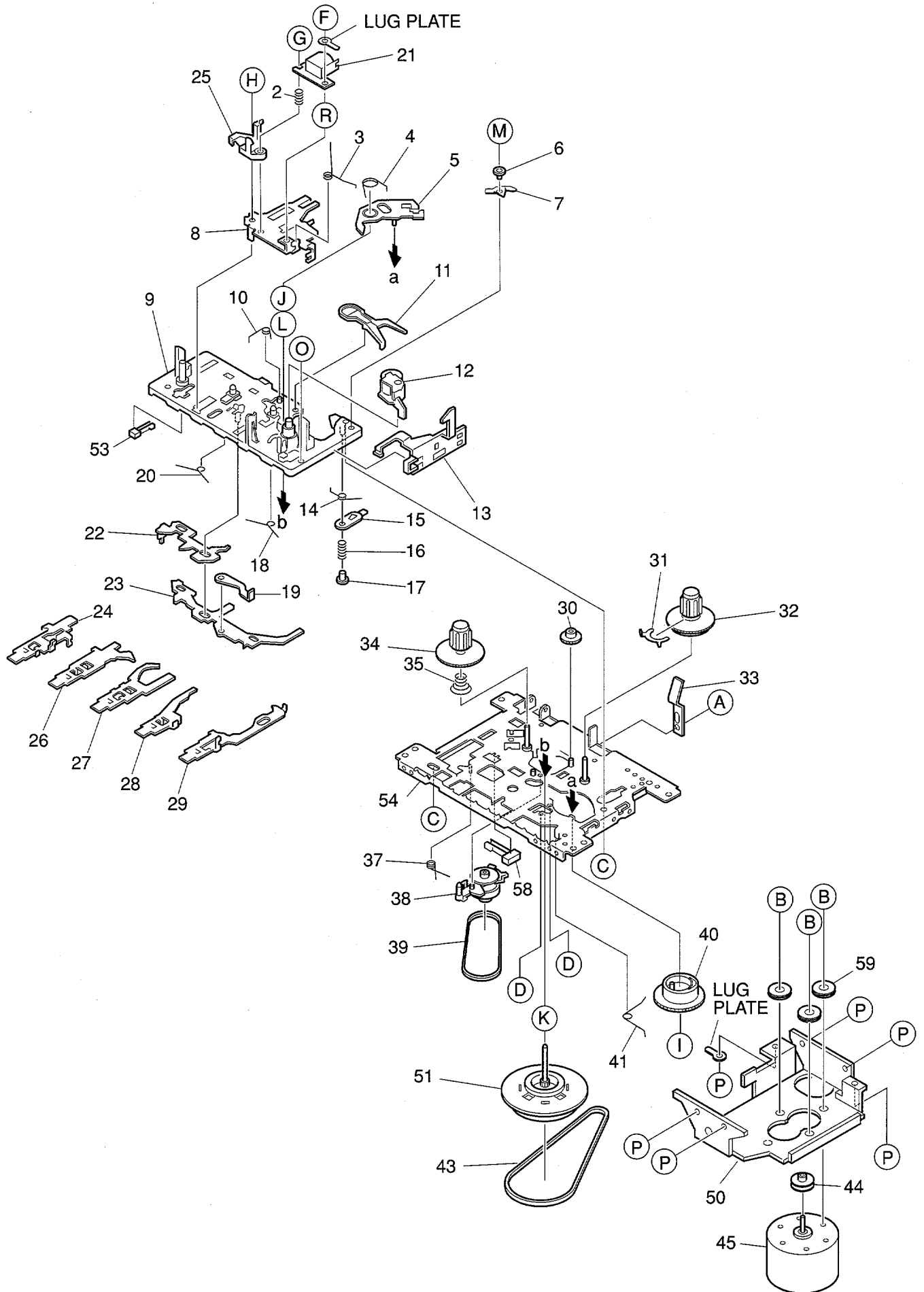

TAPE MECHANISM PARTS LIST 1/1

If can't understand for Description please kindly refer to "REFERENCE NAME LIST".

REF. NO.	PART NO.	KANRI NO.	DESCRIPTION	REF. NO.	PART NO.	KANRI NO.	DESCRIPTION
1	S1-921-030-060		HEAD BASE	41	S1-921-140-160		E ACTUATOR SPRING
2	S1-821-030-070		AZIMUTH SPRING	42	S1-921-093-210		FLYWHEEL ASSY
3	S1-921-030-090		PANEL P SPRING	43	S1-921-090-400		MAIN BELT
4	S1-921-260-050		GEAR PLATE SPRING	44	S1-921-120-130		MOTOR PULLEY
5	S1-921-265-020		GEAR PLATE ASSY	45	S6-002-030-290		MOTOR EG530YD-2BH
6	S1-921-140-370		P ARM COLLER	46	S6-207-140-030		E HEAD TC-2131
7	S1-921-140-340		P ARM	47	S1-921-030-120		HEAD PANEL
8	S1-921-030-110		HEAD PANEL	48	S1-921-140-210		REC BUTTON LEVER SPRING
9	S1-921-143-160		BASE ASSY	49	S1-821-100-690		RECORD SAFETY LEVER
10	S1-921-141-8A0		M CONTROL SPRING	50	S1-921-120-110		MOTOR BRACKET
11	S1-921-260-4A0		SENSING LEVER	51	S1-921-093-240		FLYWHEEL ASSY
12	S1-921-043-100		PINCH ROLLER ARM ASSY	52	S6-201-011-110		HEAD,RP7442ES-0951
13	S1-921-130-020		EJECT SLIDE LEVER	53	S6-401-011-490		LEAF SW MSW-1541T
14	S1-921-141-3A0		P CONTROL SPRING	54	S1-921-015-010		CHASSIS ASSY
15	S1-921-140-550		PAUSE LEVER (E)	55	S1-821-030-080		EH SPRING
16	S1-921-140-120		PAUSE LEVER SPRING	56	S6-401-011-610		LEAF SW MSW-17820MVEI
17	S1-921-140-110		PAUSE STOPPER	57	S1-921-020-010		REC ARM
18	S1-921-140-150		BUTTON LEVER SPRING (B)	58	S6-401-010-380		LEAF SWITCH MSW-1275
19	S1-821-011-590		E KICK LEVER	59	S1-820-130-060		MOTOR RUBBER
20	S1-921-140-140		BUTTON LEVER SPRING (A)	A	S9-P04-200-310		C TAPPING SCREW 2-3
21	S6-201-010-750		P HEAD RP-7442ES-0951	B	S1-821-120-020		MOTOR COLLER SCREW
22	S1-921-140-090		SWITCH ACTUATOR	C	S9-B10-200-510		P TAPPING BIND SCREW M2-5
23	S1-921-140-380		PUSH BUTTON ACTUATOR	D	S9-C07-204-510		SCREW, TAPPING (CAMERA) M2-4.5
24	S1-921-140-230		PLAY BUTTON LEVER	E	87-251-095-410		+-CAP SCREW M2-8
25	S1-921-030-4A0		HEAD BASE	F	S9-B01-200-310		(+) BIND SCREW M2-3
26	S1-921-140-240		REW BUTTON LEVER	G	S9-F08-200-710		AZIMUTH SCREW M2-7
27	S1-921-140-250		FF BUTTON LEVER	H	S9-P01-200-610		SCREW, M2-6
28	S1-921-140-260		STOP BUTTON LEVER	I	S9-W02-300-100		P WASHER CUT 1.2-3.8-0.3
29	S1-921-140-610		PAUSE BUTTON LEVER	J	S9-W02-500-100		P WASHER CUT 1.45-3.8-0.5
30	S1-821-100-700		FF GEAR	K	S9-W01-400-100		P WASHER 2-3.5-0.4
31	S1-921-050-060		SENSOR	L	S9-W01-130-200		P WASHER 2.1-4-0.13
32	S1-921-053-100		TAKE UP REEL ASSY	M	S9-P08-203-010		PS TAPPING SCREW M2-3
33	S1-829-100-010		PACK SPRING	N	S9-P04-200-510		C TAPPING SCREW M2-5
34	S1-921-050-150		S REEL HUB	O	S9-P05-200-610		SCREW, TAP S M 2-6
35	S1-921-050-220		BACK TENSION SPRING	P	S9-P04-200-410		C TAPPING SCREW M2-4
36	S1-921-140-220		REC BUTTON LEVER				
37	S1-921-140-170		P.S.LEVER SPRING				
38	S1-921-073-080		RF CLUTCH ASSY				
39	S1-921-070-030		RF BELT				
40	S1-921-260-020		CAM GEAR				

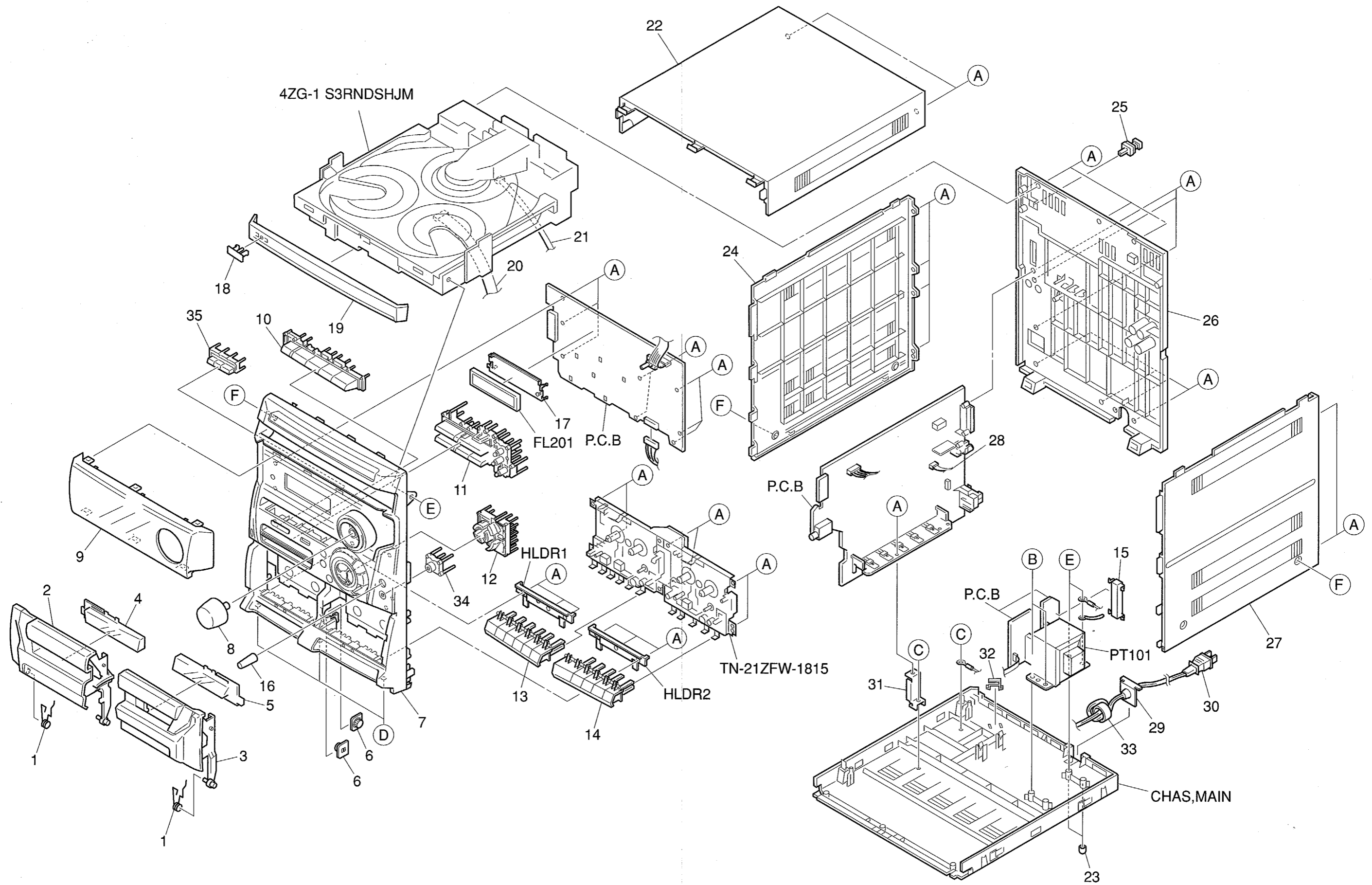

MECHANICAL PARTS LIST 1 / 1

If can't understand for Description please kindly refer to "REFERENCE NAME LIST".

REF. NO.	PART NO.	KANRI NO.	DESCRIPTION	REF. NO.	PART NO.	KANRI NO.	DESCRIPTION
1	8Z-NF7-218-010		SPR-T, CASS	22	8Z-NFA-005-010		PANEL, TOP<exp HC, 116EZ>
2	8Z-NFA-003-010		BOX, CASS 1<exp 116HC, 116EZ>	22	8Z-NFA-033-110		PANEL, TOP BLK<exp HC, 116EZ>
2	8Z-NFA-031-010		BOX, CASS 1 BLK<116HC, 116EZ>	23	8Z-NB8-240-010		COVER, PL
3	8Z-NFA-004-010		BOX, CASS 2<except 116HC, 116EZ>	24	8Z-NFA-020-110		PANEL, RIGHT SV-2<exp HC, 116EZ>
3	8Z-NFA-032-010		BOX, CASS 2P BLK<116HC, 116EZ>	24	8Z-NFA-036-010		PANEL, RIGHT SV-2 B<HC, 116EZ>
4	8Z-NFA-008-010		WINDOW, CASS 1	25	84-ZG1-245-210		CAP, OPTICAL
5	8Z-NFA-009-010		WINDOW, CASS 2	26	8Z-NFA-080-210		CABI, REAR HEJSTM<HE>
6	86-NFZ-231-010		DMPR, 70	26	8Z-NFA-062-210		CABI, REAR HRJSTM<HR>
7	8Z-NFA-002-010		CABI, FR H<HE, HR>	26	8Z-NFA-064-210		CABI, REAR KSTM<K>
7	8Z-NFA-001-010		CABI, U<111EZ, 16EZ, K, G, V, HS>	26	8Z-NFA-065-210		CABI, REAR EZSTM<111EZ>
7	8Z-NFA-021-010		CABI, FR EZ<112EZ>	26	8Z-NFA-066-210		CABI, REAR VSTM<V>
7	8Z-NFA-030-110		CABI, FR BLK<116EZ>	26	8Z-NFA-076-210		CABI, REAR EZSTM112<112EZ>
7	8Z-NFA-103-010		CABI, FR H BLK<116HC>	26	8Z-NFA-082-210		CABI, REAR EZBM116<116EZ>
8	8Z-NFA-017-010		KNOB, RTRY VOL	26	8Z-NFA-089-110		CABI, REAR EZ W/O SPEC<HS>
9	8Z-NFA-023-010		WINDOW, DISP H<HE, HR>	26	8Z-NFA-091-010		CABI, REAR GSTM<G>
9	8Z-NFA-024-010		WINDOW, DISP EZ112<112EZ>	26	8Z-NFA-092-010		CABI, REAR EZSTM16<16EZ>
9	8Z-NFA-029-010		WINDOW, DISP EZ<111EZ, K, G, V, HS>	26	8Z-NFA-093-010		CABI, REAR HCBC116<116HC>
9	8Z-NFA-040-010		WINDOW, DISP EZ116<116EZ>	27	8Z-NFA-018-010		PANEL, LEFT V-2<exp HC, 116EZ>
9	8Z-NFA-102-010		WINDOW, DISP EZ16<16EZ>	27	8Z-NFA-035-110		PANEL, LEFT V-2 B<HC, 116EZ>
9	8Z-NFA-104-010		WINDOW, DISP H116<116HC>	28	88-906-251-110		FF-CABLE, 6P 1.25
10	8Z-NFA-010-010		KEY, FUN<exp 116HC, 116EZ>	29	87-085-185-010		BUSHING, AC CORD (E)
10	8Z-NFA-041-010		KEY, FUN BLK<116HC, 116EZ>	△ 30	87-050-079-010		AC-CORD ASSY, E BLK<HR, HE, V, K, EZ>
11	8Z-NFA-011-010		KEY, OPE<exp HC, 116EZ>	△ 30	87-050-081-110		AC-CORD ASSY, G<G>
11	8Z-NFA-042-010		KEY, OPE BLK<116HC, 116EZ>	△ 30	87-A80-006-010		AC-CORD ASSY, HS<HS>
12	8Z-NFA-012-010		KEY, CD	△ 30	87-A80-083-010		AC-CORD, HC BLK<HC>
13	8Z-NFA-013-010		KEY, CASS 1<exp HC, 116EZ>	31	88-NF9-213-010		HLDR, PWB MAIN
13	8Z-NFA-037-010		KEY, CASS 1 BLK<116HC, 116EZ>	32	87-NF4-221-010		HLDR, CABLE
14	8Z-NFA-014-010		KEY, CASS 2P<exp HC, 116EZ>	33	87-003-317-010		F-BEAD, 15-25-15<exp HR, HE, HC>
14	8Z-NFA-038-010		KEY, CASS 2 BLK<HC, 116EZ>	34	8Z-NFA-100-010		COVER, MIC<HR, HE>
△ 15	87-A90-165-010		SW, SL 1-2-3 SWS2301<HE, HR, HC>	34	8Z-NFA-105-010		COVER, MIC<116HC>
16	87-NB8-017-010		KNOB, RTRY MIC<HE, HR, HC>	△ 35	87-099-881-010		PLUG, ADPFR CONV<K>
17	8Z-NFA-204-010		GUIDE, FL 100-25	A	87-067-703-010		TAPPING SCREW, BVT2+3-10
18	82-NE6-067-010		BADGE, AIWA 30N	B	87-078-191-010		S-SCREW, IT+4-10
19	8Z-NFA-006-010		PANEL, TRAY<exp HC, 116EZ>	C	87-067-584-010		TAPPING SCREW, BVT2+3-6
19	8Z-NFA-034-010		PANEL, TRAY BLK<HC, 116EZ>	D	87-067-688-010		BVTT+3-6
20	83-NE2-618-110		F-CABEL, 5P-2.5	E	87-721-097-410		QT2+3-12 GLD
21	88-913-221-110		FF-CABLE, 13P 1.25 220MM	F	87-067-641-010		UTT2+3-8(W/O SLOT)BL

NOTE : exp = except

COLOR NAME TABLE

Basic color symbol	Color	Basic color symbol	Color	Basic color symbol	Color
B	Black	C	Cream	D	Orange
G	Green	H	Gray	L	Blue
LT	Transparent Blue	N	Gold	P	Pink
R	Red	S	Sliver	ST	Titan Silver
T	Brown	V	Violet	W	White
WT	Transparent White	Y	Yellow	YT	Transparent Yellow
LM	Metallic Blue	LL	Light Blue	GT	Transparent Green
LD	Dark Blue	DT	Transparent Orange		

SPEAKER DISASSEMBLY INSTRUCTIONS

Type.1

Insert a flat-bladed screwdriver into the position indicated by the arrows and remove the panel. Remove the screws of each speaker unit and then remove the speaker units.

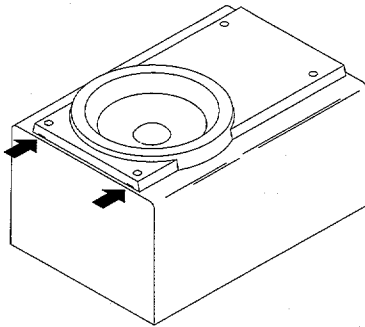

Type.2

Remove the grill frame and four pieces of rubber caps by pulling out with a flat-bladed screwdriver. Remove the screws from hole where installed rubber caps. Insert a flat-bladed screwdriver into the position indicated by the arrows and remove the panel. Remove the screws of each speaker unit and then remove the speaker units.

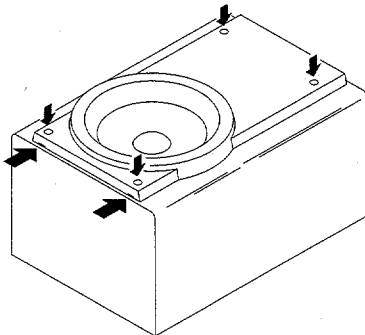

Type.3

Insert a flat-bladed screwdriver into the position indicated by the arrows and remove the panel. Turn the speaker unit to counter-clockwise direction while inserting a flat-bladed screwdriver into one of the hollows around speaker unit, and then remove the speaker unit. After replacing the speaker unit, install it turning to clockwise direction until "click" sound comes out.

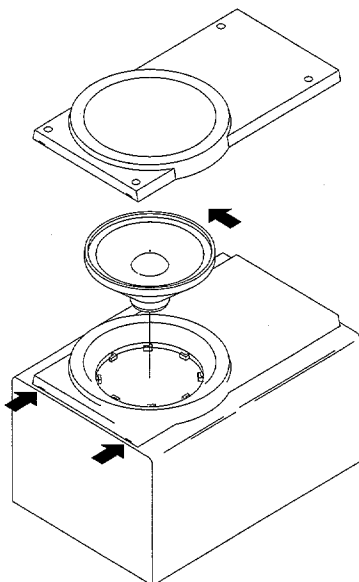

Type.4

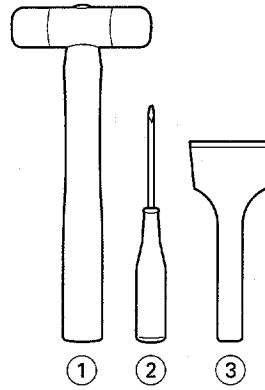

TOOLS

- ① Plastic head hammer
- ② (⊖) flat head screwdriver
- ③ Cut chisel

How to Remove the PANEL, FR

1. Insert the (⊖) flat head screwdriver tip into the gap between the PANEL, FR and the PANEL, SPKR. Tap the head of the (⊖) flat head screwdriver with the plastic hammer head, and create the clearance as shown in Fig-1.
2. Insert the cut chisel in the clearance, and tap the head of the cut chisel with plastic hammer as shown in Fig-2, to remove the PANEL, FR.
3. Place the speaker horizontally. Tap head of the cut chisel with plastic hammer as shown in Fig-3, and remove the PANEL, FR completely.

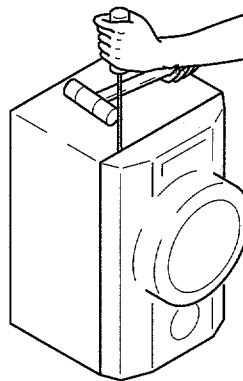

Fig-1

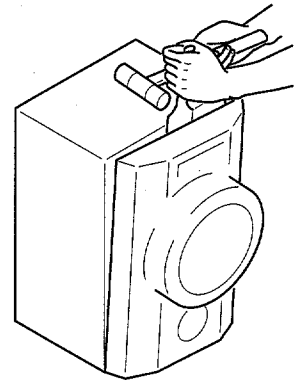

Fig-2

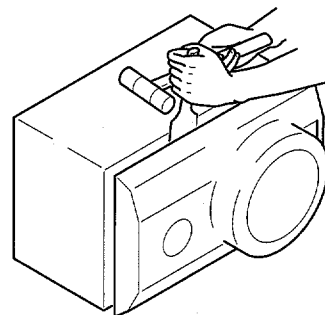

Fig-3

How to Attach the PANEL, FR

Attach the PANEL, FR to the PANEL, SPKR. Tap the four corners of the PANEL, FR with the plastic hammer to fit the PANEL, FR into the PANEL, SPKR completely.

SPEAKER PARTS LIST (SX-NS112/SX-NS116 : YJSTC,YSTC/YBC2NC1,YBC)

If can't understand for Description please kindly refer to " REFERENCE NAME LIST ".

REF. NO.	PART NO.	KANRI NO.	DESCRIPTION
1	8Z-NSL-001-010		PANEL,FR <NS112>
1	8Z-NSL-013-010		PANEL,FR B <NS116>
2	8Z-NSL-003-010		GRILLE,FRAME ASSY
3	87-NS7-611-010		CORD,SPKR
4	87-NSH-612-010		SPKR,CERAMIC ASSY
5	8Z-NSL-601-010		SPKR,W 120
6	8Z-NSL-025-010		PROTECTOR,SHEET

ACCESSORIES / PACKAGE LIST

If can't understand for Description please kindly refer to " REFERENCE NAME LIST ".

REF. NO.	PART NO.	KANRI NO.	DESCRIPTION
1	8Z-NFA-901-010		IB,H(ECA)M<HR,HE>
1	8Z-NFA-905-010		IB,K(E)M<K>
1	8Z-NFA-906-110		IB,EZ(9L)M<111EZ,116EZ,16EZ,HS>
1	8Z-NFA-907-010		IB,V(ER)M<V>
1	8Z-NFA-915-010		IB,G(E)M<G>
1	8Z-NFA-916-010		IB,EZ(9L)M -112<112EZ>
1	8Z-NFA-935-010		IB,H(EC-K)S<HC>
2	87-043-106-010		ANT,FM 1007AWG<EZ,G,K,HS>
2	87-043-115-010		ANT,FEEDER FM<HR,HE,HC,V>
3	87-A90-030-010		ANT,LOOP AM-NC C<EZ,K,G,HS,V>
3	87-A90-054-010		ANT,LOOP AM-CON C<HR,HE,HC>
4	87-A90-119-010		ANT,WIRE SW(5M)<HR,HE,HC>
5	87-A91-017-010		PLUG,CONVERSION JT-0476<HR,HE>
5	87-A91-015-010		PLUG,CONVERSION JT-0475A<HC>
6	8Z-NF9-701-210		RC UNIT,ZAS02<EXCEPT HC,116EZ,16EZ>
6	8Z-NF9-702-010		RC UNIT,ZAS02<HC>
6	8Z-NF9-703-110		RC UNIT,ZAS17<116EZ,16EZ>

REFERENCE NAME LIST

ELECTRICAL SECTION

DESCRIPTION	REFERENCE NAME
ANT	ANTENNAS
C-	CHIP
C-CAP	CAP, CHIP
C-CAP TN	CAP, CHIP TANTALUM
C-COIL	COIL, CHIP
C-DI	DIODE, CHIP
C-DIODE	DIODE, CHIP
C-FET	FET, CHIP
C-FOTR	FILTER, CHIP
C-JACK	JACK, CHIP
C-LED	LED, CHIP
C-RES	RES, CHIP
C-SFR	SFR, CHIP
C-SLIDE SW	SLIDE SWITCH, CHIP
C-SW	SWITCH, CHIP
C-TR	TRANSISTOR, CHIP
C-VR	VOLUME, CHIP
C-ZENER	ZENER, CHIP
CAP, CER	CAP, CERA-SOL
CAP, E	CAP, ELECT
CAP, M/F	CAP, FILM
CAP, TC	CAP, CERA-SOL
CAP, TC-U	CAP, CERA-SOL SS
CAP, TN	CAP, TANTALUM
CERA FIL	FILTER, CERAMIC
CF	FILTER, CERAMIC
DL	DELAY LINE
E/CAP	CAP, ELECT
FILT	FILTER
FLTR	FILTER
FUSE RES	RES, FUSE
MOT	MOTOR
P-DIODE	PHOTO DIODE
P-SNSR	PHOTO SENSER
P-TR	PHOTO TRANSISTOR
POLY VARI	VARIABLE CAPACITOR
PPCAP	CAP, PP
PT	POWER TRANSFORMER
PTR, RES	PTR, MELF
RC	REMOTE CONTROLLER
RES NF	RES, NON-FLAMMABLE
RESO	RESONATOR
SHLD	SHIELD
SOL	SOLENOID
SPKR	SPEAKER
SW, LVR	SWITCH, LEVER
SW, RTRY	SWITCH, ROTARY
SW, SL	SWITCH, SLIDE
TC CAP	CAP, CERA-SOL
THMS	THERMISTOR
TR	TRANSISTOR
TRIMER	CAP, TRIMMER
TUN-CAP	VARIABLE CAPACITOR
VIB, CER	RESONATOR, CERAMIC
VIB, XTAL	RESONATOR, CRYSTAL
VR	VOLUME
ZENER	DIODE, ZENER

MECHANICAL SECTION

DESCRIPTION	REFERENCE NAME
ADHESHIVE	SHEET ADHESHIVE
AZ	AZIMUTH
BAR-ANT	BAR-ANTENNA
BAT	BATTERY
BATT	BATTERY
BRG	BEARING
BTN	BUTTON
CAB	CABINET
CASS	CASSETTE
CHAS	CHASSIS
CLR	COLLAR
CONT	CONTROL
CRSR	CURSOR
CU	CUSHION
CUSH	CUSHION
DIR	DIRECTION
DUBB	DUBBING
FL	FRONT LOADING
FLY-WHL	FLYWHEEL
FR	FRONT
FUN	FUNCTION
G-CU	G-CUSHION
HDL	HANDOL
HIMERON	CLOTH
HINGE, BAT	HINGE, BATTERY
HLDR	HOLDER
HT-SINK	HEAT SINK
IB	INSTRUCTION BOOKLET
IDLE	IDLER
IND, L-R	INDICATOR, L-R
KEY, CONT	KEY, CONTROL
KEY, PRGM	KEY, PROGRAM
KNOB, SL	KNOB, SLIDE
LBL	LABEL
LID, BATT	LID, BATTERY
LID, CASS	LID, CASSETTE
LVR	LEVER
P-SP	P-SPRING
PANEL, CONT	PANEL, CONTROL
PANEL, FR	PANEL, FRONT
PRGM	PROGRAM
PULLY, LOAD MO	PULLY, LOAD MOTOR
RBN	RIBBON
S-	SPECIAL
SEG	SEGMENT
SH	SHEET
SHLD-SH	SHIELD-SHEET
SL	SLIDE
SP	SPRING
SP-SCREW	SPECIAL-SCREW
SPACER, BAT	SPACER, BATTERY
SPR	SPRING
SPR-P	P-SPRING
SPR-PC-PUSH	P-SPRING, C-PUSH
T-SP	T-SPRING
TERM	TERMINAL
TRIG	TRIGGER
TUN	TUNING
VOL	VOLUME
W	WASHER
WHL	WHEEL
WORM-WHL	WORM-WHEEL

サービス技術ニュース	
番号	連絡内容
G-	-
G-	-
G-	-

アイワ株式会社
AIWA CO., LTD.

9301896, 931261

Tokyo Japan