

aiwa

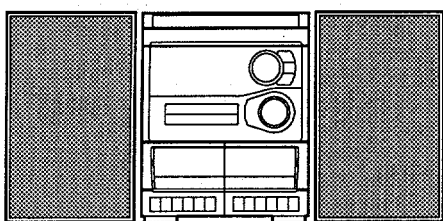

NSX-S201 NSX-S202 NSX-S203



CD STEREO SYSTEM

- BASIC TAPE MECHANISM: TN-21ZFW-1788
- BASIC CD MECHANISM: 4ZG-1 Z3DLSHNM/Z4DLSHNC
- TYPE: LH,EZ,K,V

REVISION PUBLISHING

System	CD Mechanism		Tape Mechanism
	Z3DLSHNM	Z4DLSHNC	
NSX-S201<LH> NSX-S202<EZ,K,V> NSX-S203<EZ>	201<LH> 202<EZ> STNM 203<EZ> STNM	202<EZ,K> STNE 202<EZ,K,V> STNC 203<EZ> STNC, STNE	TN-21ZFW-1788

SYSTEM	CD CASSEIVER	SPEAKER	REMOTE CONTROLLER
NSX-S201	CX-NS201	SX-SNS202	RC UNIT,6AS14
NSX-S202	CX-NS202	SX-NS202	
NSX-S203	CX-NS203	SX-NS202	

- This Service Manual is the "Revision Publishing" and replaces "Simple Manual", S/M Code No. 09-986-285-20A and 09-986-285-2FE.
- If requiring information about the CD mechanism, see Service Manual of 4ZG-1. (S/M Code No.09-983-249-3OT)

SERVICE MANUAL

SPECIFICATIONS

<FM Tuner section> (LH,EZ,K)

Tuning range 87.5 MHz to 108 MHz
 Usable sensitivity(IHF) 16.8 dBf
 Antenna terminals 75 ohms (unbalanced)

<FM Tuner section> (V)

Tuning range FM1 (OIRT)
 65 MHz to 74 MHz (10 kHz step)
 FM2 (CCIR)
 87.5 MHz to 108 MHz (10 kHz step)
 Usable sensitivity(IHF) FM1 : 15.3 dBf
 FM2 : 12.8 dBf
 Antenna terminals 75 ohms (unbalanced)

<AM (MW) Tuner section>

Tuning range 531 kHz to 1602 kHz (9 kHz step)
 530 kHz to 1710 kHz (10 kHz step)
 Usable sensitivity 350 uV/m
 Antenna Loop antenna

<LW Tuner section> (EZ,K)

Tuning range 144 kHz to 290 kHz
 Usable sensitivity 1400 uV/m
 Antenna Loop antenna

<Amplifier section>

Power output Rated : 12 W + 12 W (6 ohms,
 THD 1%, 1 kHz/DIN 45500)
 Reference : 15 W + 15 W (6 ohms,
 THD 10%, 1 kHz/DIN 45324)
 DIN MUSIC POWER: 35 W + 35 W
 Total harmonic distortion 0.1% (6 W, 1 kHz, 6 ohms,
 DIN AUDIO)
 Inputs VIDEO/AUX : 500 mV
 Outputs SPEAKERS: accept speakers of
 6 ohms or more
 PHONES (stereo jack) : accepts
 headphones of 32 ohms or more

<Cassette deck section>

Track format 4 tracks, 2 channels stereo
 Frequency response 50 Hz - 10000 Hz
 Recording system AC bias
 Heads Deck 1 : Recording/Playback head
 x 1, erase head x 1
 Deck 2 : Playback head x 1

<Compact disc player section>

Laser Semiconductor laser ($\lambda = 780 \text{ nm}$)
 D-A converter 1 bit dual
 Signal-to-noise ratio 85 dB (1 kHz, 0 dB)
 Harmonic distortion 0.05 % (1 kHz, 0 dB)
 Wow and flutter Unmeasurable

<Speaker system SX-NS202

Cabinet type 2 way, bass reflex
 (magnetic shielded type)
 Speakers Woofer : 120 mm cone type
 Tweeter : 20 mm ceramic type
 Impedance 6 ohms
 Output sound pressure level 87 dB/W/m
 Dimensions (W x H x D) 230 x 324 x 250 mm
 Weight 3.2 kg

<General>

Power requirements 230 V AC, 50 Hz
 Power consumption 55 W
 Dimensions of main unit 260 x 324 x 337 mm
 Weight of main unit 4.6 kg

• Design and specifications are subject to change without notice.

ACCESSORIES / PACKAGE LIST

If can't understand for Description please kindly refer to "REFERENCE NAME LIST".

REF. NO.	PART NO.	KANRI NO.	DESCRIPTION
1	88-NF9-905-010	IB,K(E)H<K>	
1	88-NF9-906-010	IB,E(E9L)H<202EZ>	
1	88-NF9-907-010	IB,V(ER)H<V>	
1	88-NF9-916-010	IB,E(9L)203H<203EZ>	
1	88-NF9-923-010	IB,LH(P)CCE 201<LH>	
2	87-006-225-010	AM LOOP ANT NC2	
3	87-043-115-010	ANT,FEEDER FM<LH,V>	
4	87-A90-118-010	ANT,WIRE FM(Z)<EZ,K>	
5	88-NF9-660-010	RC UNIT,6AS14	

PROTECTION OF EYES FROM LASER BEAM DURING SERVICING

This set employs laser. Therefore, be sure to follow carefully the instructions below when servicing.

WARNING!!

WHEN SERVICING, DO NOT APPROACH THE LASER EXIT WITH THE EYE TOO CLOSELY. IN CASE IT IS NECESSARY TO CONFIRM LASER BEAM EMISSION. BE SURE TO OBSERVE FROM A DISTANCE OF MORE THAN 30cm FROM THE SURFACE OF THE OBJECTIVE LENS ON THE OPTICAL PICK-UP BLOCK.



- Caution: Invisible laser radiation when open and interlocks defeated avoid exposure to beam.
- Advarsel: Usynlig laserstråling ved åbning, når sikkerhedsafbrydere er ude af funktion. Undgå udsættelse for stråling.

VAROITUS!

Laiteen Käyttäminen muulla kuin tässä käyttöohjeessa mainituilla tavalla saattaa altistaa käyttäjän turvallisuusluokan 1 ylitävälle näkymättömälle lasersäteilylle.

WARNING!

Om apparaten används på annat sätt än vad som specificeras i denna bruksanvisning, kan användaren utsättas för osynlig laserstrålning, som överskrider gränsen för laserklass 1.

CAUTION

Use of controls or adjustments or performance of procedures other than those specified herein may result in hazardous radiation exposure.

ATTENTION

L'utilisation de commandes, réglages ou procédures autres que ceux spécifiés peut entraîner une dangereuse exposition aux radiations.

ADVARSEL!

Usynlig laserstråling ved åbning, når sikkerhedsafbrydere er ude af funktion. Undgå udsættelse for stråling.

This Compact Disc player is classified as a CLASS 1 LASER product.

The CLASS 1 LASER PRODUCT label is located on the rear exterior.

CLASS 1	LASER PRODUCT
KLASSE 1	LASER PRODUKT
LUOKAN 1	LASER LAITE
KLASS 1	LASER APPARAT

Precaution to replace Optical block

(KSS - 213C)

Body or clothes electrostatic potential could ruin laser diode in the optical block. Be sure ground body and workbench, and use care the clothes do not touch the diode.

- 1) After the connection, remove solder shown in right figure.

PICK-UP Assy P.C.B

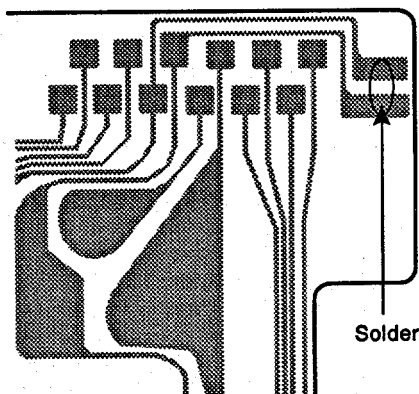

NOTE ON BEFORE STARTING REPAIR

1. Forced discharge of electrolytic capacitor of power supply block

When repair is going to be attempted in the set that uses relay circuit in the power supply block, electric potential is kept charged across the electrolytic capacitors (C101, 102) even though AC power cord is removed. If repair is attempted in this condition, the secondary defect can occur.

In order to prevent the secondary trouble, perform the following measures before starting repair work.

Discharge procedure

- ① Remove the AC power cord.
- ② Connect a discharging resistor at an end of lead wire that has clips at both ends. Connect the other end of the lead wire to metal chassis.
- ③ Contact the other end of the discharging resistor to the positive (+) side (+VH) of C101. (For two seconds)
- ④ Contact the same end of the discharging resistor as step ③ to the negative (-) side (-VH) of C102 in the same way. (For two seconds)
- ⑤ Check that voltage across C101 and C102 has decreased 1 V or less using a multimeter or an oscilloscope.

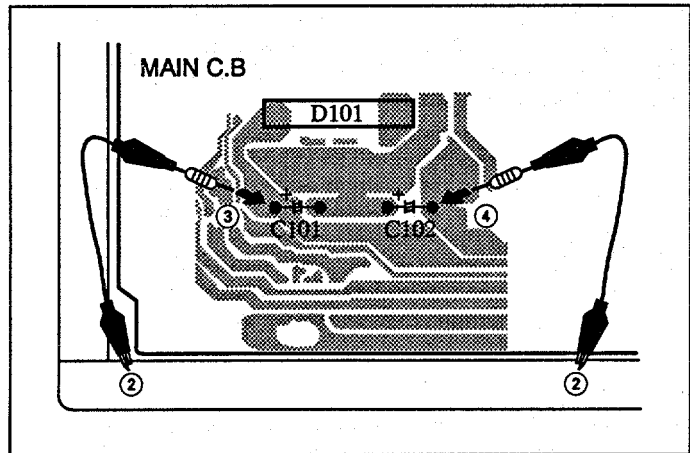

Fig-1

Select a discharging resistor referring to the following table.

Charging voltage (V) (C101, 102)	Discharging resistor (Ω)	Rated power (W)	Parts number
25-48	100	3	87-A00-247-090
49-140	220	5	87-A00-232-090

Note: The reference numbers (C101, C102) of the electrolytic capacitors can change depending on the models. Be sure to check the reference numbers of the charging capacitors on schematic diagram before starting the discharging work.

2. Check items before exchanging the MICROCOMPUTER

Be sure to check the following items before exchanging the MICROCOMPUTER. Exchange the MICROCOMPUTER after confirming that the MICROCOMPUTER is surely defective.

2-1. Regarding the HOLD terminal of the MICROCOMPUTER

When the HOLD terminal (INPUT) of the MICROCOMPUTER is "H", the MICROCOMPUTER is judged to be operating correctly. When this terminal is "L", the main power cannot be turned on. Therefore, be sure to check the terminal voltage of the HOLD terminal before exchange.

When the MICROCOMPUTER is not defective, the HOLD terminal can also go "L" when the POWER AMPLIFIER has any abnormalities that triggers the abnormality detection circuit on the MAIN C. B. that sets the HOLD terminal to "L".

• Good or no good judgement of the MICROCOMPUTER

- ① Turn on the AC main power.
- ② Confirm that the main power is turned on and the HOLD terminal of the MICROCOMPUTER keeps the "H" level or not.
- ③ When the HOLD terminal is "L" level, the abnormality detection circuit is judged to be working correctly and the MICROCOMPUTER is judged to be good.

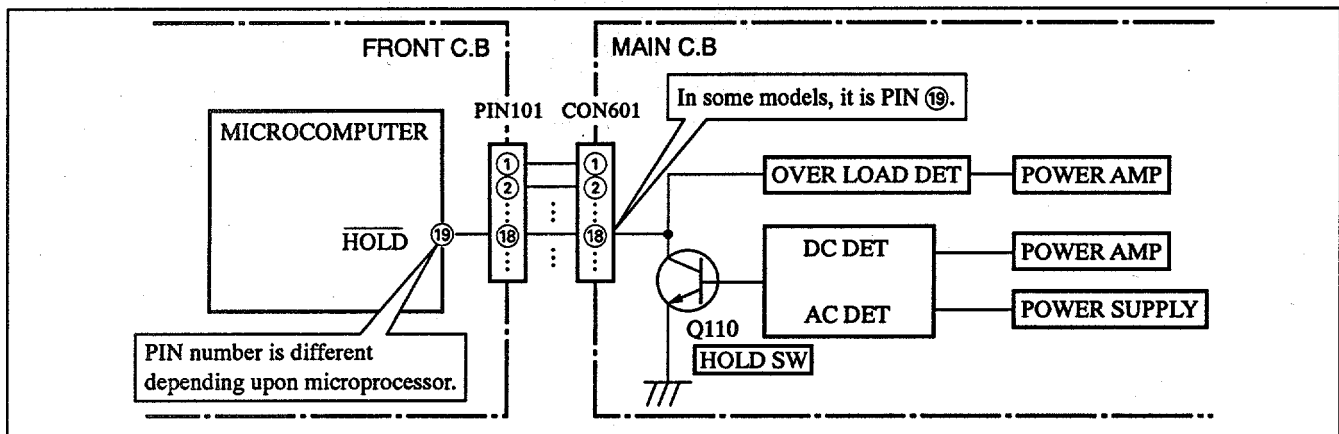

Fig-2-1

In such a case, check also if the POWER AMPLIFIER circuit or power supply circuit has any abnormalities or not.

2-2. Regarding reset

There are cases that the machine does not work correctly because the MICROCOMPUTER is not reset even though the AC power cord is re-inserted, or the software reset (pressing the STOP key + POWER key) is performed.

When the above described phenomenon occurs, it can lead to wrong judgement as if the MICROCOMPUTER is defective and to exchange the MICROCOMPUTER. In such a case, perform the forced-reset by the following procedure and check good or no good of the MICROCOMPUTER.

- ① Remove the AC power cord.

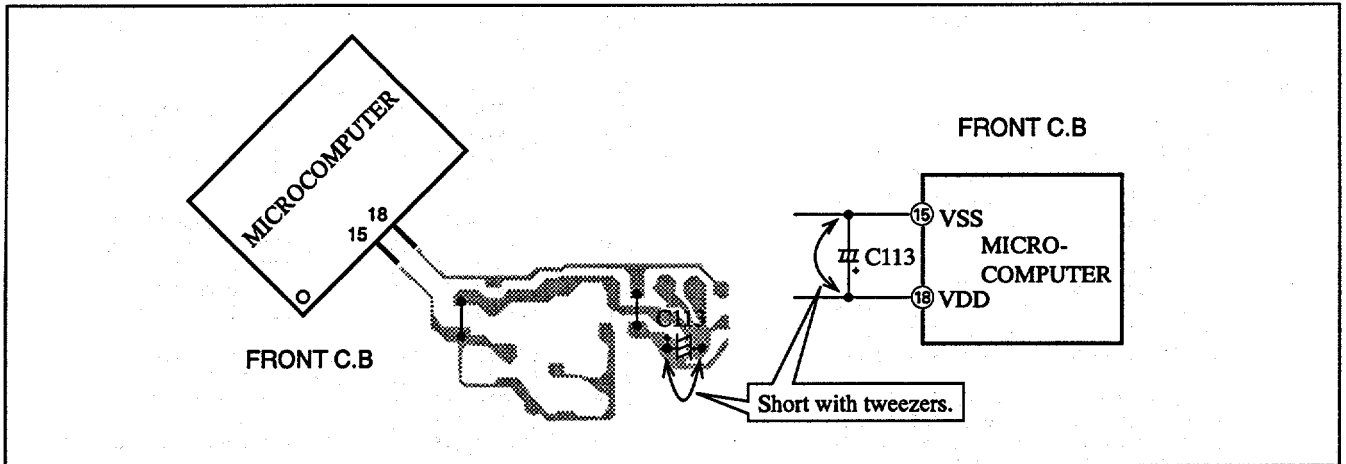

Fig-2-2

- ② Short both ends of the electrolytic capacitor C113 that is connected to VDD of the MICROCOMPUTER with tweezers.
- ③ Connect the AC power cord again. If the MICROCOMPUTER returns to the normal operation, the MICROCOMPUTER is good.

Note: The reference number or MICROCOMPUTER pin number of transistor (Q110) and electrolytic capacitor (C113) can change depending on the models. Be sure to check the reference numbers on schematic diagram before starting the discharging work.

2-3. Confirmation of soldering state of MICROCOMPUTER

Check the soldering state of the MICROCOMPUTER in addition to the above described procedures. Be sure to exchange the MICROCOMPUTER after surely confirming that the trouble is not caused by poor soldering but the MICROCOMPUTER itself.

ELECTRICAL MAIN PARTS LIST

If can't understand for Description please kindly refer to "REFERENCE NAME LIST".

REF. NO.	PART NO.	KANRI NO.	DESCRIPTION	REF. NO.	PART NO.	KANRI NO.	DESCRIPTION
IC				C219	87-010-544-080		CAP, ELECT 0.1-50V
	87-A20-502-010	IC, BU1920		C220	87-010-544-080		CAP, ELECT 0.1-50V
	88-NF9-653-010	IC, LA1837NZ		C221	87-018-211-080		CAP, CER 0.01-50<EZ, K>
	88-NF9-656-010	IC, LC72131DZ		C222	87-018-211-080		CAP, CER 0.01-50<EZ, K>
	88-NF9-659-010	IC, M38B57MCH-P202FP		C223	87-018-134-080		CAPACITOR, TC-U 0.01-16<EZ, K>
	88-NF9-632-010	IC, M62439SP		C224	87-018-134-080		CAPACITOR, TC-U 0.01-16<EZ, K>
	87-017-889-010	IC, NJM4558LD		C229	87-018-123-080		CAP, CER 220P-50V
	87-A20-951-010	IC, TSOP1838RF1		C230	87-018-123-080		CAP, CER 220P-50V
TRANSISTOR				C237	87-018-134-080		CAPACITOR, TC-U 0.01-16
	89-213-702-010	TR, 2SB1370E		C239	87-010-402-080		CAP, ELECT 2.2-50V
	88-NF9-622-010	TR, 2SB1616		C240	87-010-402-080		CAP, ELECT 2.2-50V
	87-A30-196-080	TR, 2SC4115SRS		C253	87-018-131-080		CAP, CER 1000P-50V<EZ, K>
	89-305-352-380	TR, 2SC535(B/C)<EZ, K, V>		C254	87-018-131-080		CAP, CER 1000P-50V<EZ, K>
	88-NF9-623-010	TR, 2SD2478		C255	87-018-115-080		CAP, CER 47P-50V<EZ, K>
	87-A30-091-080	FET, 2SJ460		C256	87-018-115-080		CAP, CER 47P-50V<EZ, K>
	87-A30-090-080	FET, 2SK2541		C257	87-018-119-080		CAP, CER 100P-50V<EZ, K>
	87-A30-092-080	FET, 2SK439E/F<EZ, K>		C258	87-018-119-080		CAP, CER 100P-50V<EZ, K>
	87-A30-164-080	TR, CSC2001K<EZ, K>		C301	87-018-197-080		CAP, CER 1800P-16V
	87-026-269-080	TR, DTA114ES<EZ, K>		C302	87-018-197-080		CAP, CER 1800P-16V
	87-026-214-080	TR, DTA114YS (0.3W)		C303	87-018-196-080		CAP, CER 1500P-16V
	87-026-219-080	TR, DTA144ES (0.3W)		C304	87-018-196-080		CAP, CER 1500P-16V
	87-026-218-080	TR, DTC144ES (0.2W)		C307	87-010-263-080		CAP, ELECT 100-10V
	87-026-609-080	TR, KTA1266GR		C308	87-010-263-080		CAP, ELECT 100-10V
	87-A30-197-080	TR, KTA1267GR		C309	87-018-115-080		CAP, CER 47P-50V<EZ, K>
	87-026-610-080	TR, KTC3198GR		C310	87-018-115-080		CAP, CER 47P-50V<EZ, K>
	87-A30-198-080	TR, KTC3199GR		C315	87-010-375-080		CAP, E 330-10 SME<LH, V>
	87-026-372-080	TR, RN1210		C317	87-010-546-080		CAP, ELECT 0.33-50V
DIODE				C318	87-010-546-080		CAP, ELECT 0.33-50V
	87-A40-454-080	DIODE, 1N5393 GW		C322	87-018-209-080		CAP, CER 0.1-50V<EZ, K>
	87-A40-393-090	DIODE, 1N5402GW F20		C325	87-018-209-080		CAP, CER 0.1-50V<EZ, K>
	87-A40-336-080	ZENER, MTZJ27D T-72		C326	87-018-209-080		CAP, CER 0.1-50V<EZ, K>
	87-A40-470-080	DIODE, 1SS254		C327	87-018-209-080		CAP, CER 0.1-50V<EZ, K>
	87-A40-308-080	ZENER, DZ10M		C329	87-018-134-080		CAPACITOR, TC-U 0.01-16<V>
	87-A40-345-080	ZENER, MTZJ10C		C360	87-010-401-080		CAP, ELECT 1-50V
	87-070-274-080	DIODE, 1N4003 SEM		C361	87-010-374-080		CAP, ELECT 47-10V
	87-A40-304-080	ZENER, DZ6.2M		C401	87-010-401-080		CAP, ELECT 1-50V<LH, V>
	87-017-932-080	ZENER, MTZJ6.2B		C401	87-010-400-080		CAP, ELECT 0.47-50V<EZ, K>
	87-A40-292-080	ZENER, DZ2.7L		C402	87-010-401-080		CAP, ELECT 1-50V<LH, V>
	87-A40-466-080	ZENER, MTZJ2.7A		C402	87-010-400-080		CAP, ELECT 0.47-50V<EZ, K>
	87-A40-302-080	ZENER, DZ5.6M		C403	87-018-118-080		CAP, TC-U 82P-50 B
	87-017-931-080	ZENER, MTZJ5.6B		C404	87-018-118-080		CAP, TC-U 82P-50 B
MAIN C.B				C411	87-010-405-080		CAP, ELECT 10-50V
C101	87-016-495-090	CAP, E 3300-25 SMG		C412	87-010-405-080		CAP, ELECT 10-50V
C104	87-A10-011-090	CAP, E 2200-25 SMG		C452	87-010-382-080		CAP, ELECT 22-25V
C105	87-018-127-080	CAP, CER 470P-50V		C459	87-018-128-080		CAP, CERA-SOL SS 560P
C106	87-010-260-080	CAP, ELECT 47-25V		C461	87-018-126-080		CAP, TC-U 390P-50 B
C107	87-010-384-080	CAP, ELECT 100-25		C462	87-018-126-080		CAP, TC-U 390P-50 B
C108	87-010-381-080	CAP, ELECT 330-16V		C601	87-018-195-080		CAP, CER 1200P-16V
C111	87-010-247-080	CAP, ELECT 100-50V		C602	87-018-195-080		CAP, CER 1200P-16V
C112	87-010-263-080	CAP, ELECT 100-10V		C611	87-010-545-080		CAP, ELECT 0.22-50V
C113	87-010-403-080	CAP, ELECT 3.3-50V		C612	87-010-545-080		CAP, ELECT 0.22-50V
C114	87-010-374-080	CAP, ELECT 47-10V		C613	87-010-545-080		CAP, ELECT 0.22-50V
C122	87-010-384-080	CAP, ELECT 100-25V		C614	87-010-545-080		CAP, ELECT 0.22-50V
C123	87-010-384-080	CAP, ELECT 100-25V		C615	87-018-104-080		CAP, TC-U 10P-50 SL
C127	87-018-134-080	CAPACITOR, TC-U 0.01-16<V>		C616	87-010-260-080		CAP, ELECT 47-25V
C130	87-018-131-080	CAPACITOR, CER 1000P-50V<V>		C617	87-010-260-080		CAP, ELECT 47-25V
C207	87-010-544-080	CAP, ELECT 0.1-50V		C701	87-010-404-080		CAP, ELECT 4.7-50V
C208	87-010-544-080	CAP, ELECT 0.1-50V		C702	87-018-134-080		CAPACITOR, TC-U 0.01-16
C209	87-018-133-080	CAPACITOR, CER 4700P-16V		C703	87-018-134-080		CAPACITOR, TC-U 0.01-16
C210	87-018-133-080	CAPACITOR, CER 4700P-16V		C704	87-018-131-080		CAP, CER 1000P-50V
C211	87-010-402-080	CAP, ELECT 2.2-50V		C705	87-018-131-080		CAP, CER 1000P-50V
C212	87-010-402-080	CAP, ELECT 2.2-50V		C706	87-018-131-080		CAP, CER 1000P-50V
C213	87-010-260-080	CAP, ELECT 47-25V		C707	87-010-112-080		CAP, ELECT 100-16V
C214	87-010-260-080	CAP, ELECT 47-25V		C709	87-010-248-080		CAP, ELECT 220-10V

REF. NO.	PART NO.	KANRI NO.	DESCRIPTION
S304	87-A90-164-080	SW, TACT	SKQAB(N)
S305	87-A90-164-080	SW, TACT	SKQAB(N)
S306	87-A90-164-080	SW, TACT	SKQAB(N)
S307	87-A90-164-080	SW, TACT	SKQAB(N)
S308	87-A90-164-080	SW, TACT	SKQAB(N)
S309	87-A90-164-080	SW, TACT	SKQAB(N)
S310	87-A90-164-080	SW, TACT	SKQAB(N)
S311	87-A90-164-080	SW, TACT	SKQAB(N)
S312	87-A90-164-080	SW, TACT	SKQAB(N)
S313	87-A90-164-080	SW, TACT	SKQAB(N)
S314	87-A90-164-080	SW, TACT	SKQAB(N)
S315	87-A90-164-080	SW, TACT	SKQAB(N)
S316	87-A90-164-080	SW, TACT	SKQAB(N)
S317	87-A90-164-080	SW, TACT	SKQAB(N)
S318	87-A90-164-080	SW, TACT	SKQAB(N)
S319	87-A90-164-080	SW, TACT	SKQAB(N)<203EZ>
S320	87-A90-164-080	SW, TACT	SKQAB(N)
S321	87-A90-164-080	SW, TACT	SKQAB(N)<203EZ>
S322	87-A90-164-080	SW, TACT	SKQAB(N)<203EZ>
SFR201	87-A90-556-080	SFR, 2.2K H	HOKU
X201	87-A70-075-080	VIB, CER	4.19MHZ CRHF
AC2 C.B			
WH101	87-A90-460-010	HLDR, WIRE	2.5-7P
AC1 C.B			
△ F101	87-035-219-010	FUSE, 500MA	'T'<LH>
△ F101	87-035-217-010	FUSE, 315MA	'T'<EZ, K, V>
△ FC101	87-033-147-010	FUSE CLAMP	
△ FC102	87-033-147-010	FUSE CLAMP	
△ PT101	88-NF9-608-010	PT, 8NF-9	EKZ<EZ, K, V>
△ PT101	88-NF9-609-010	PT, 8NF-9	LH<LH>
△ SW101	87-A90-165-010	SW, SL 1-2-3	SWS2301<LH>
△ T1	87-A60-317-010	TERMINAL, 1P	MSC
△ T2	87-A60-317-010	TERMINAL, 1P	MSC

TRANSISTOR ILLUSTRATION

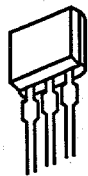

B C E

2SC4115S



E C B

2SC535
CSC2001
KTA1266
KTC3198



B C E

2SB1370



E C B

DTA114ES
DTA114YS
DTA144ES
DTC144ES
RN1210



S D G

2SJ460



B C E

2SB1616
2SD2478



E C B

KTA1267
KTC3199



S D G

2SK2541



G S D

2SK439E

BLOCK DIAGRAM - 1 (EZ, K : MAIN C.B 2 / 2)

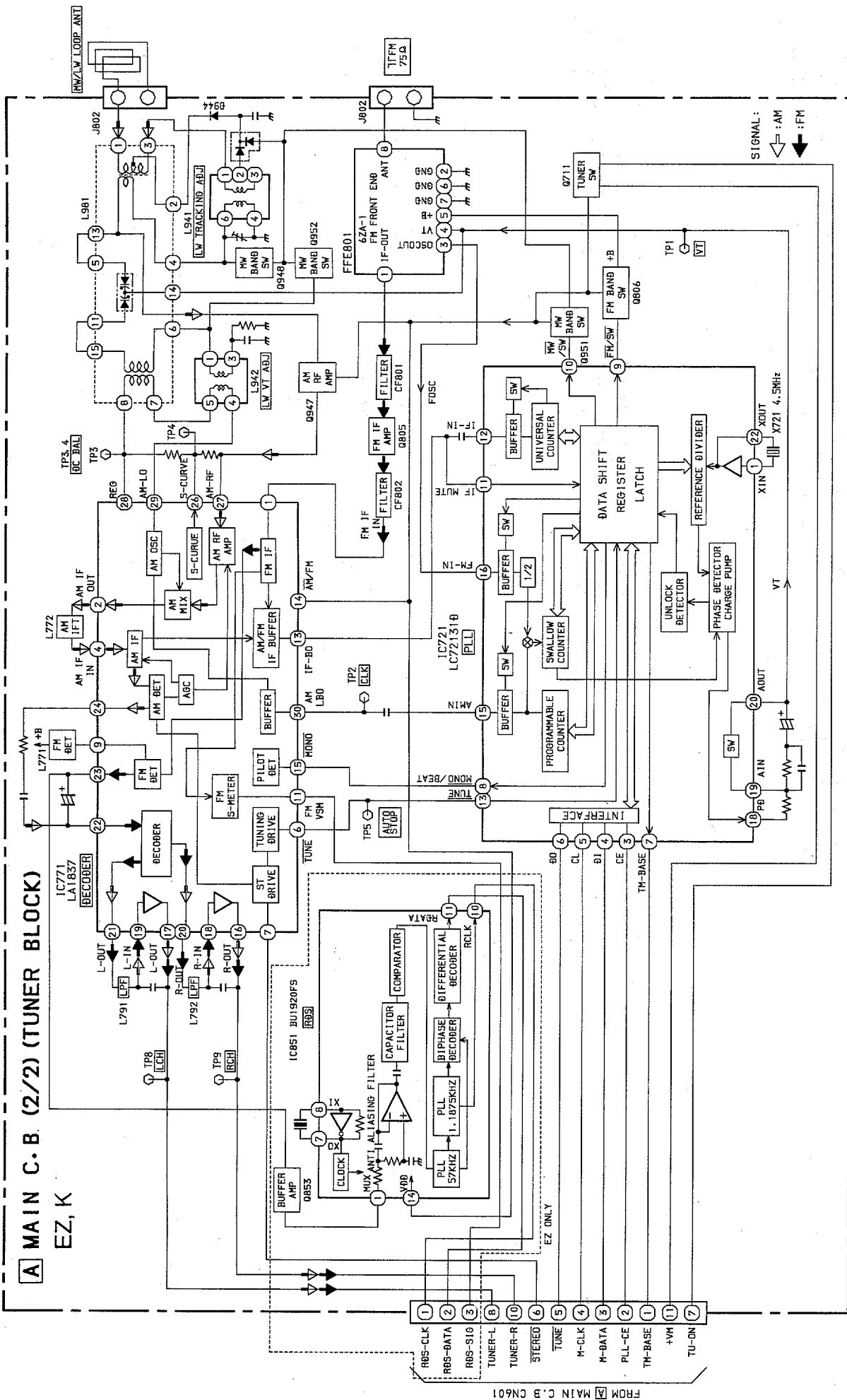

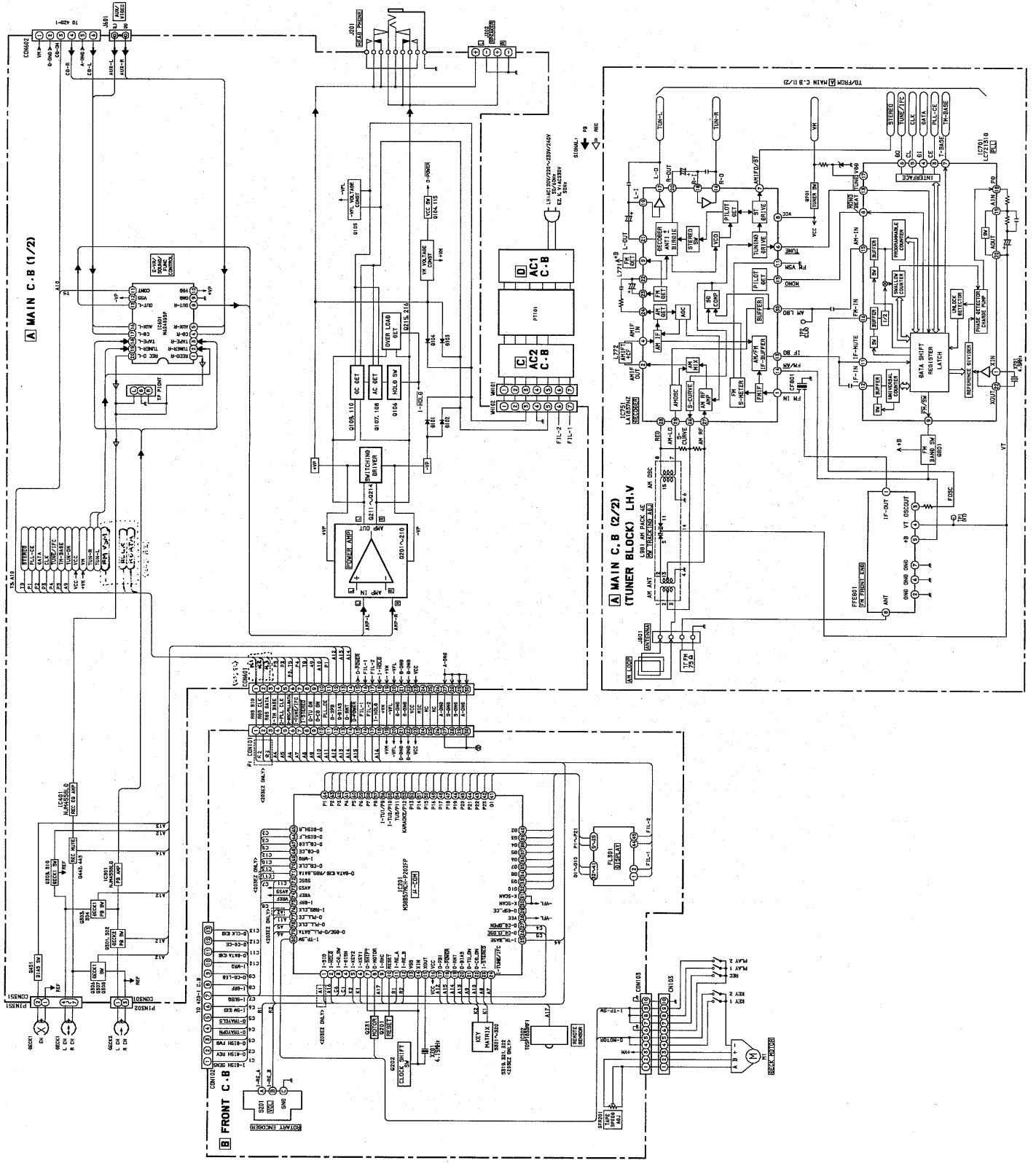

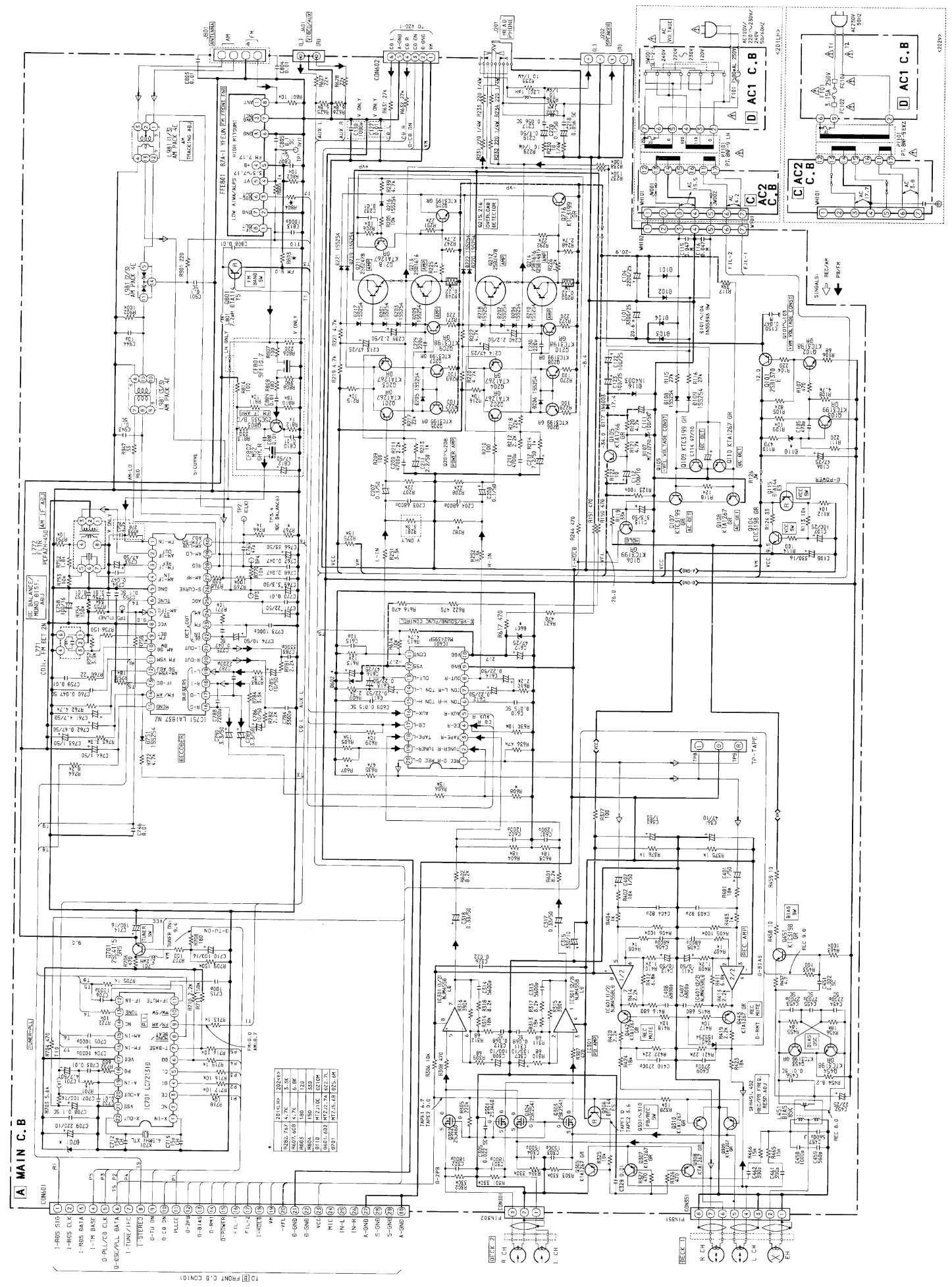

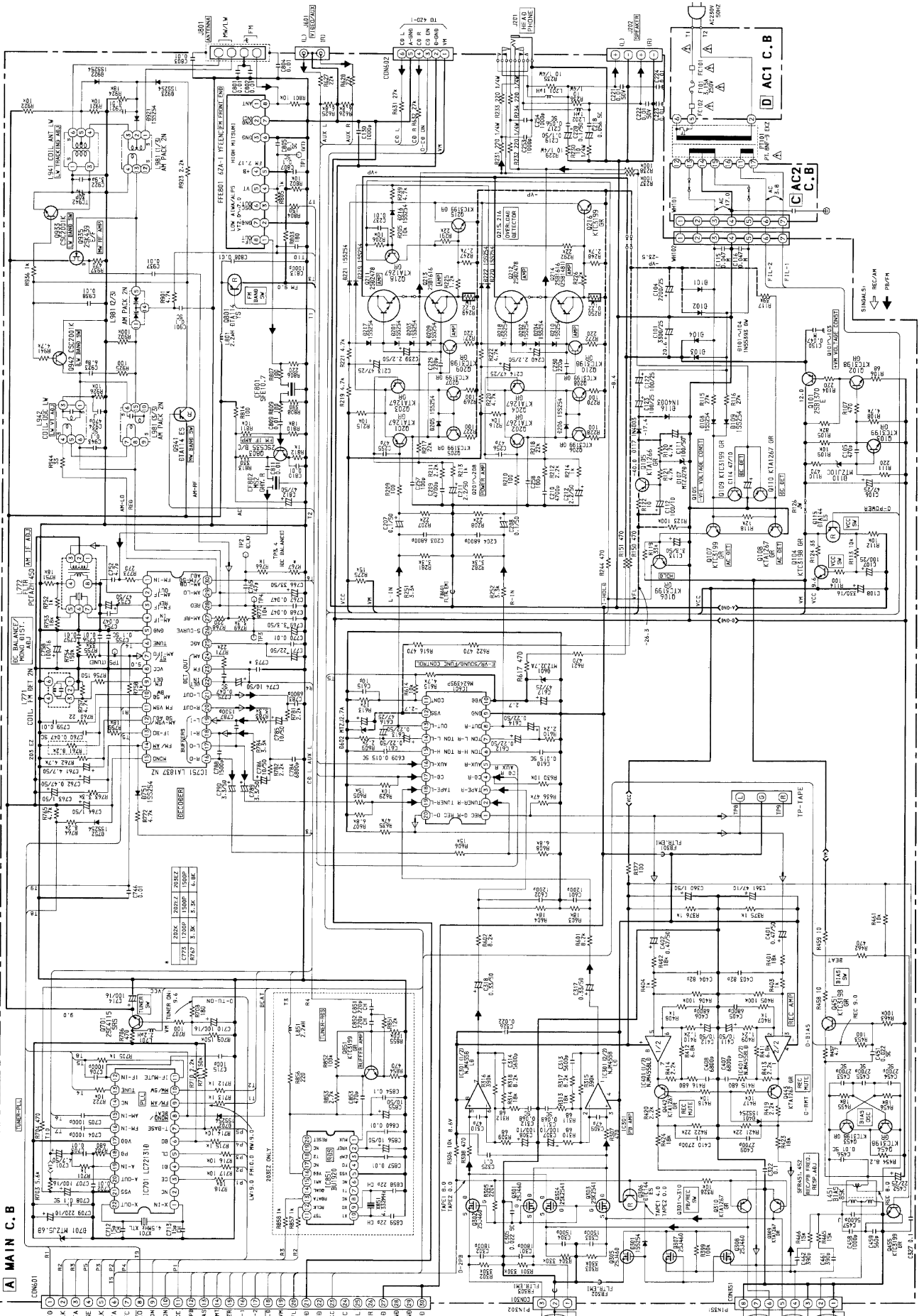

1 2 3 4 5 6 7 8 9 10 11 12 13 14

A MAIN C.B

FROM BECK 2
PIN302
TO CON601

FROM BECK 1
PIN351
TO CON601

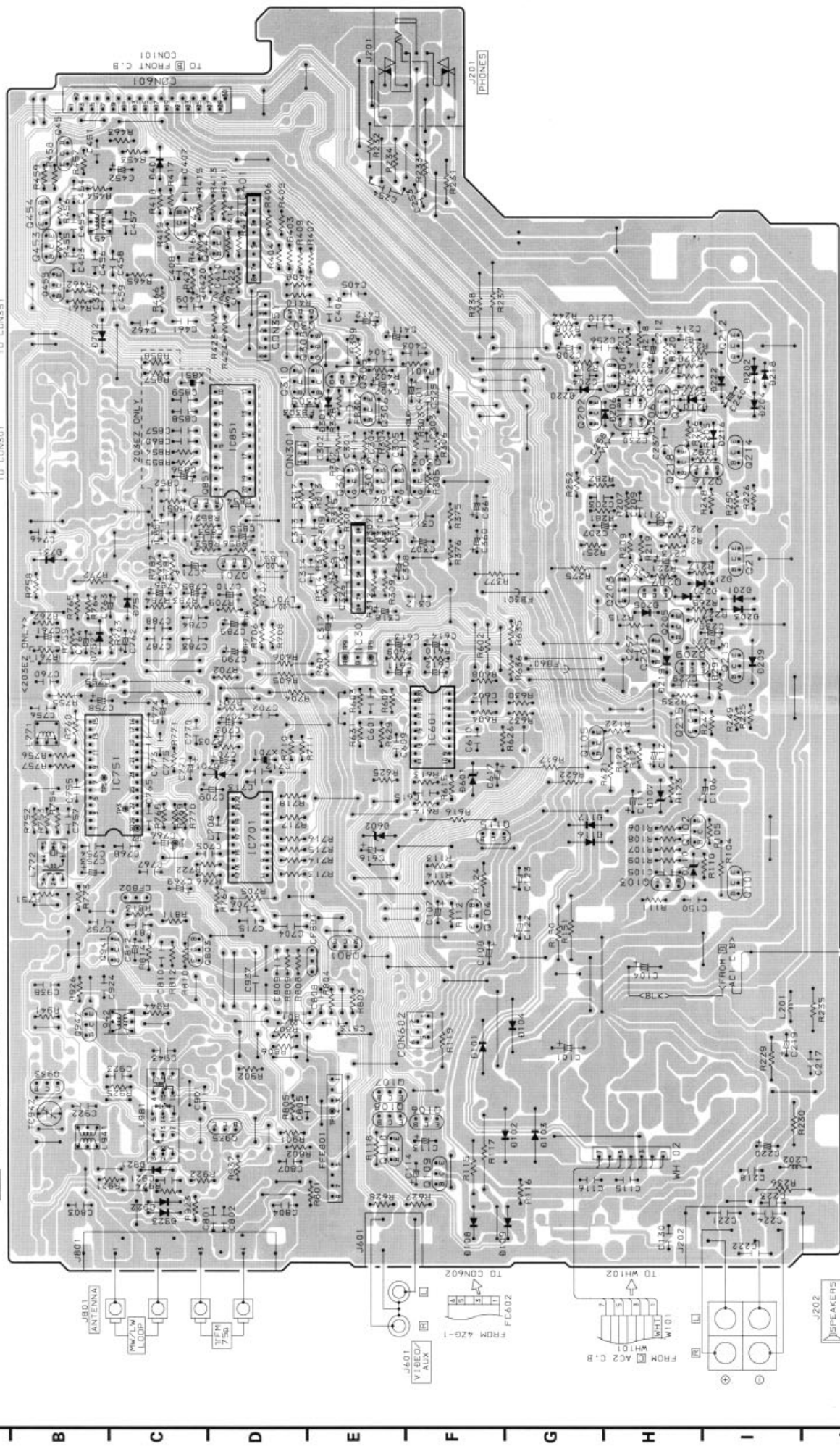

1

2

3

4

5

6

7

8

9

10

11

12

13

14

A

B FRONT C.B

TO 420-1

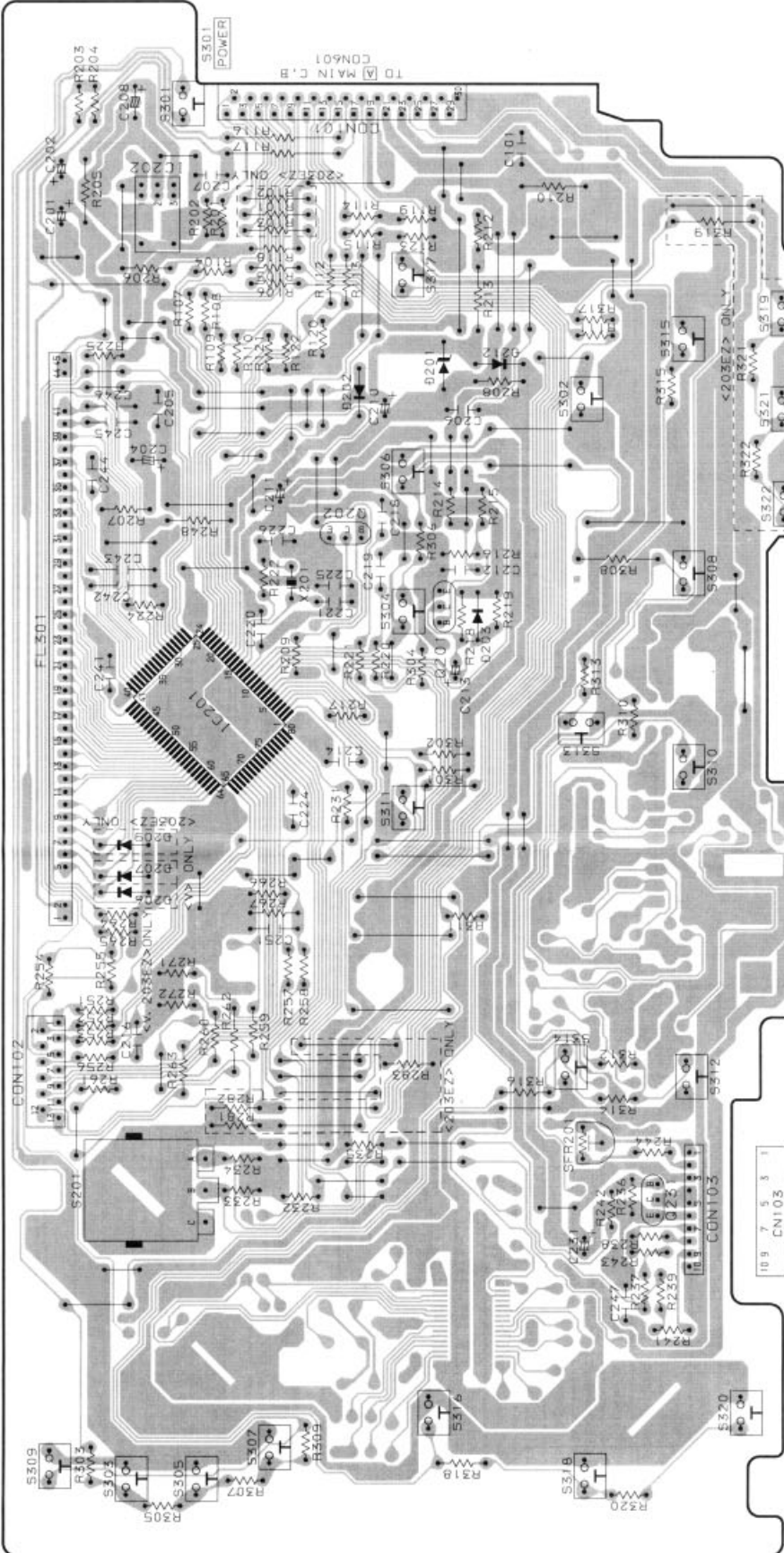

FL GRID ASSIGNMENT AND ANODE CONNECTION

GRID ASSIGNMENT

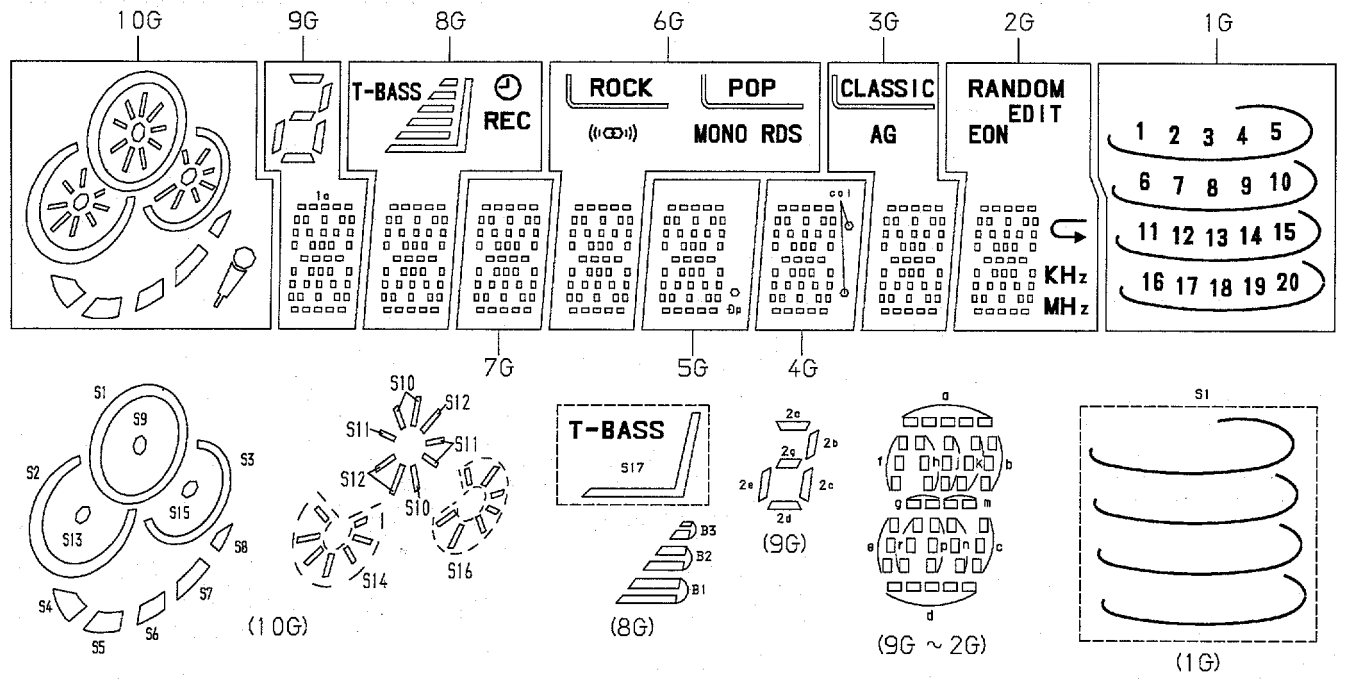

ANODE CONNECTION

	10G	9G	8G	7G	6G	5G	4G	3G	2G	1G
P1	S6	1d	d	d	d	d	d	d	d	20
P2	S7	1n	n	n	n	n	n	n	n	19
P3	S8	1p	p	p	p	p	p	p	p	18
P4	S14	1r	r	r	r	r	r	r	r	17
P5	S13	1e	e	e	e	e	e	e	e	16
P6	S2	1c	c	c	c	c	c	c	c	15
P7	S16	1g	g	g	g	g	g	g	g	14
P8	S15	1m	m	m	m	m	m	m	m	13
P9	S3	1f	f	f	f	f	f	f	f	12
P10	S12	1b	b	b	b	b	b	b	b	11
P11	S11	1k	k	k	k	k	k	k	k	10
P12	S10	1j	j	j	j	j	j	j	j	9
P13	S9	1h	h	h	h	h	h	h	h	8
P14	S1	1a	a	a	a	a	a	a	a	7
P15	S5	-	REC	-		Ep	COL (DOWN)	-	MHz	6
P16	S4	-		-	MONO	-	COL (UP)	-	KHz	5
P17		2a, 2g 2d	S17	-	RDS	-	-	AG		4
P18	-	2e	B1	-		-	-		EON	3
P19	-	2c	B2	-		-	-	-	EDIT	2
P20	-	2b	B3	-	ROCK POP	-	-	CLASSIC	RANDOM	1
P21	-	-	-	-	-	-	-	-	-	S1

WIRING - 4 (AC1 / AC2)

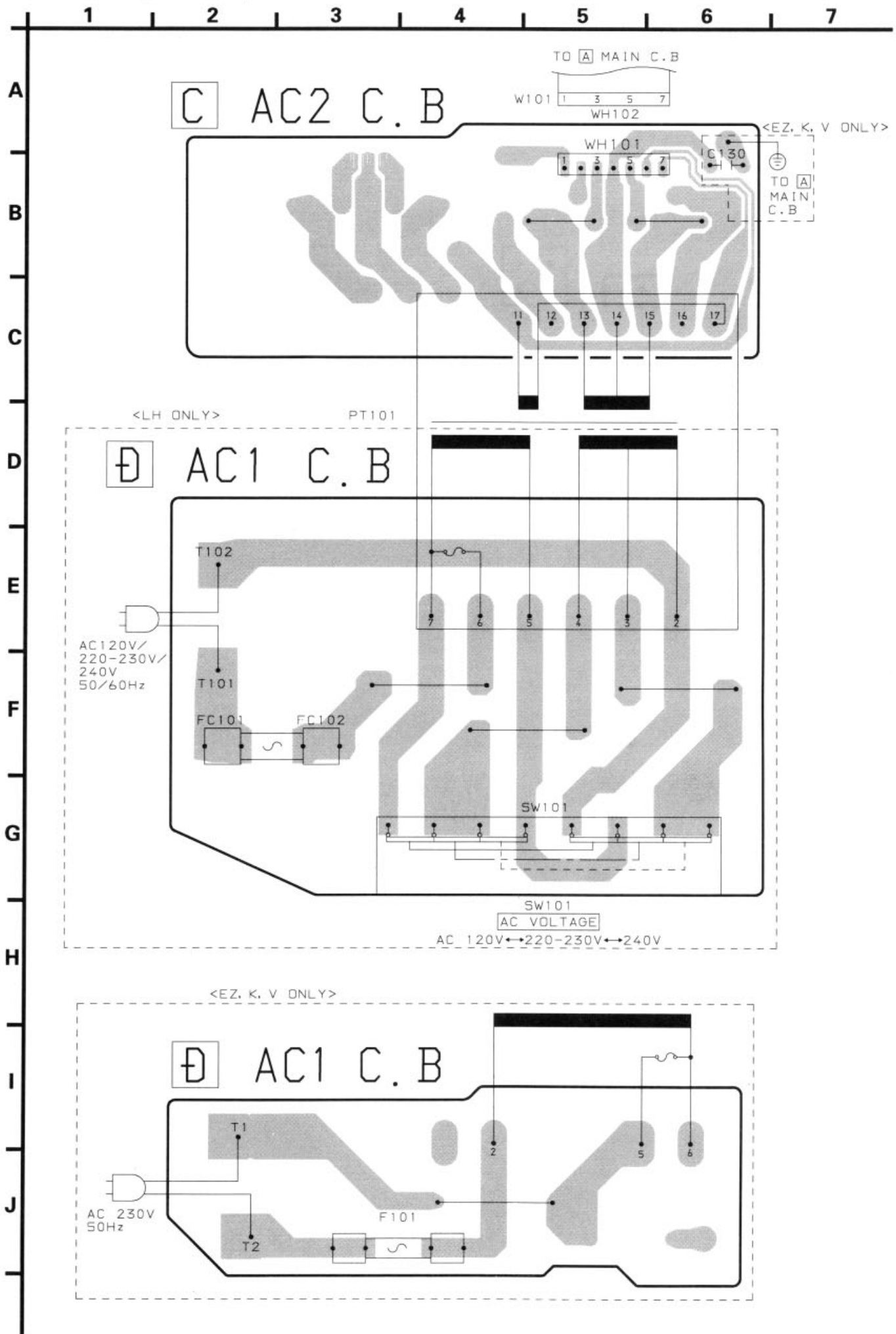

WIRING - 5 (DECK)

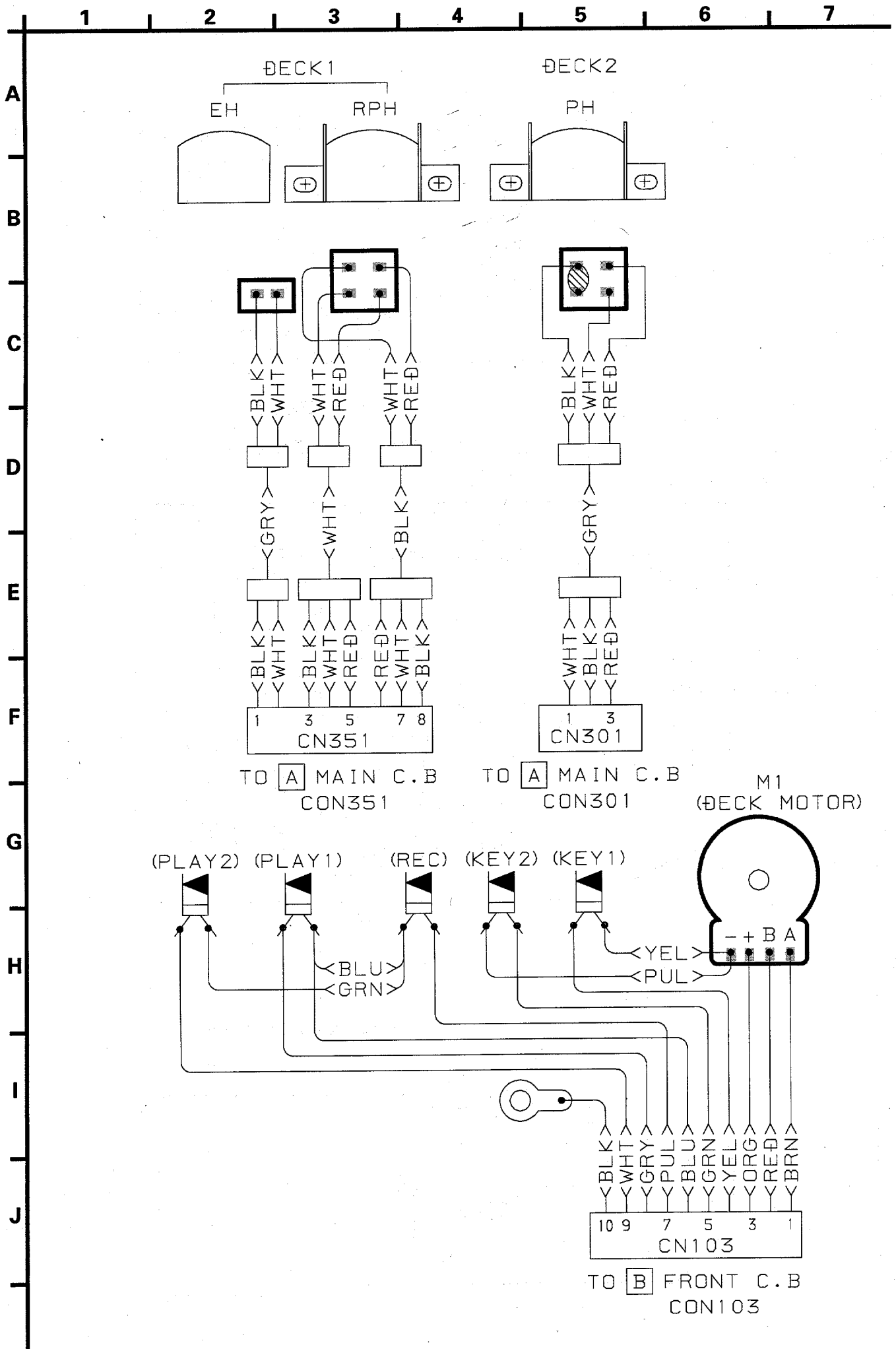

IC BLOCK DIAGRAM - 1

IC, LA1837

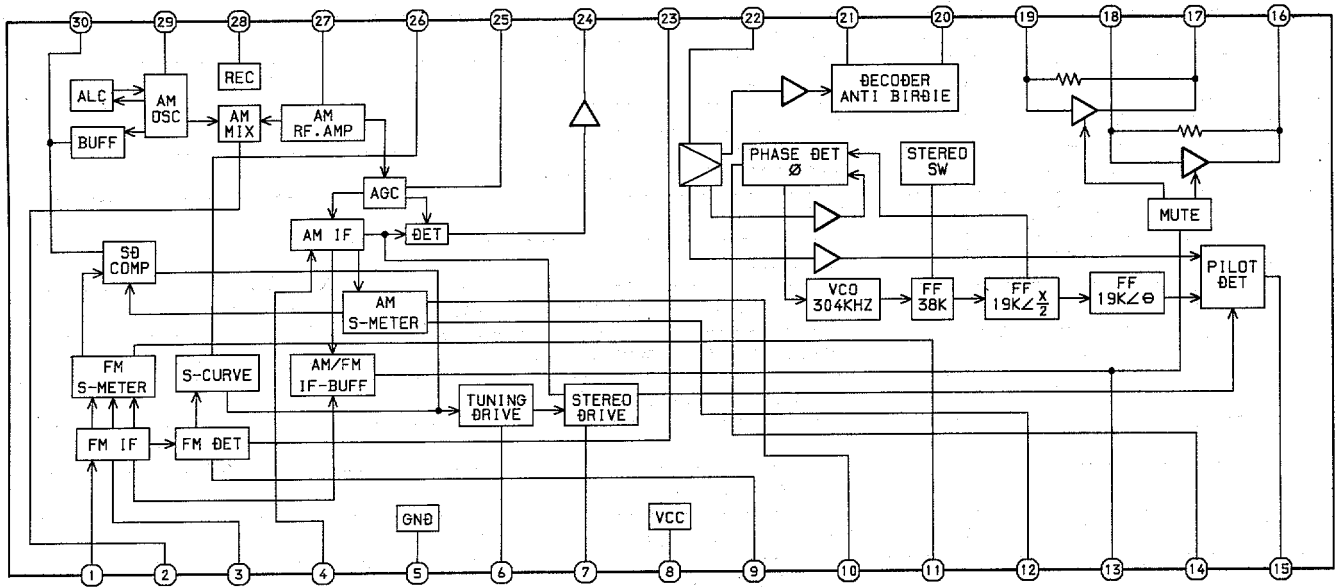

IC, M62439SP

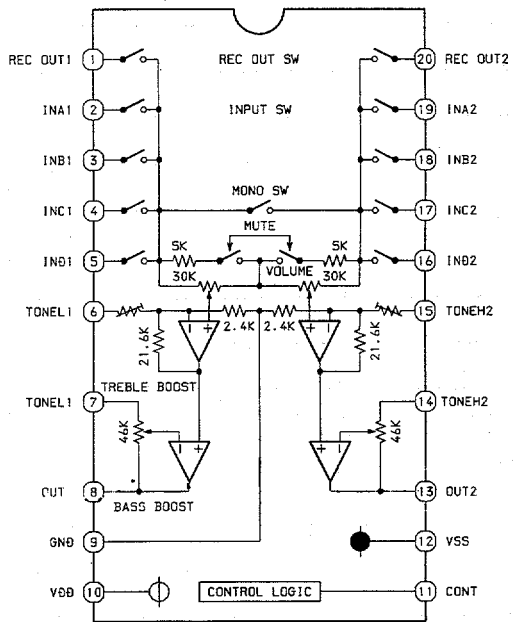

IC, BU1920FS

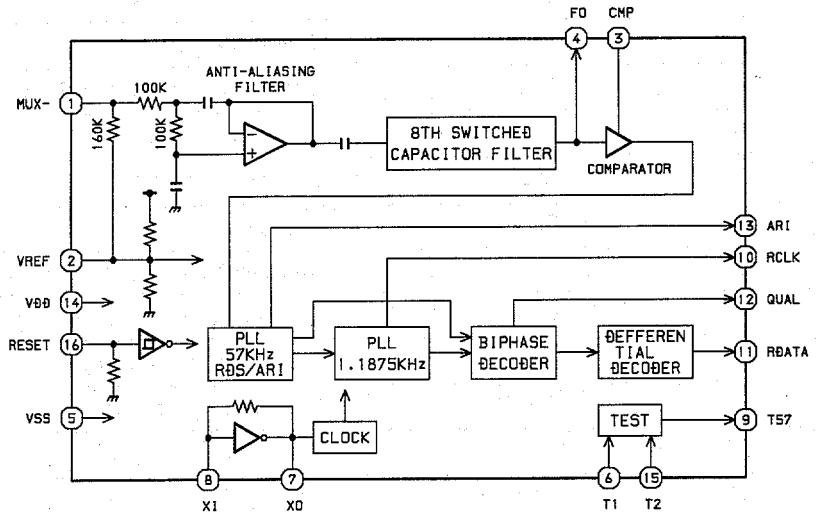

IC, LC72131

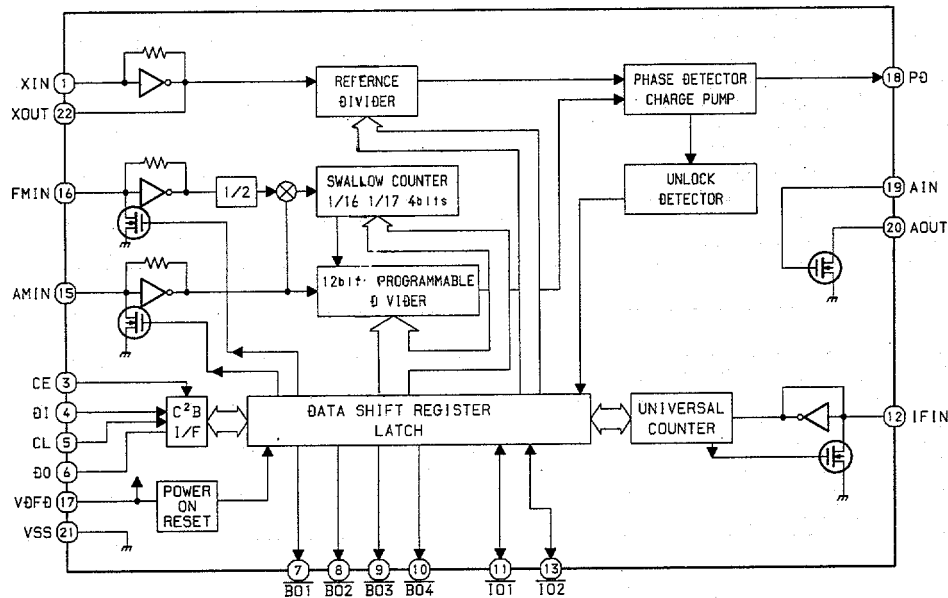

IC DESCRIPTION
IC, M38B57MCH-P202FP

Pin No.	Pin Name	I/O	Description
1	I-SIG	I	Signal level for RDS A/D input.
2	I-HOLD	I	Hold input.
3	I-CD_SW	I	CD mechanical switch input.
4	I-DISH	I	CD turntable photo sensor input.
5	I-KEY2	I	KEY input 1.
6	I-KEY1	I	KEY input 2.
7	O-SHIFT	O	Clock shift output for microcomputer when tuner receiving broadcast.
8	O-MOTOR	O	Cassette deck motor control output.
9	I-RMC	I	System remote control signal input.
10	RESET	I	RESET input.
11	I-RE_A	I	Rotary encoder A input.
12	I-RE_B	I	Rotary encoder B input.
13	VSS	-	Connected to GND.
14	XIN	-	4.19 MHz oscillator circuit.
15	XOUT	-	
16	VCC	-	Power supply.
17	O-PB1	O	Cassette deck output switching.
18	O-POWER	O	Power control output.
19	O-RMT	O	REC MUTE output.
20	O-BIAS	O	Bias output.
21	O-TU_ON	O	Tuner power supply ON/OFF output.
22	O-CD_ON	O	CD power supply ON/OFF output.
23	I-STEREO	I	Tuner stereo detected input.
24	I-TUNE/IFC	I	Tuner signal input (Active Low) / Tune IF count serial data input.
25	I-TM_BASE	I	Reference clock input for timer watch.
26	O-CD_CLOSE	O	CD tray close data output.
27	O-CD_OPEN	O	CD tray open data output.
28	VEE	-	Power supply input for FL display.
29	O-DSP_CE	O	DSP chip enable output.
30	K-SCAN	O	Initial scan output.
31	K-SCAN	O	Initial scan output.
32~41	G10~G1	O	FL grid output G1~G10.
42~43	P23~P24	O	FL segment output (Not connected).
44~62	P21~P3	O	FL segment output.
63	P2	I/O	FL segment output/TU2 input to diode.
64	P1	O	FL segment output.
65	O-DISH_R	O	CD turntable reverse rotation output.
66	O-DISH_F	O	CD turntable forward rotation output.
67	O-CD_LED	O	CD flash window output.
68	O-CD_CE	O	CD IC control output.
69	I-WRQ	I	CD IC control output.
70	O-CD_CLK	O	CD clock output.

Pin No.	Pin Name	I/O	Description
71	O-DATA(CD)/ RDS_DATA	O	CD data output.
72	SQSO	O	CD SUBQ data output.
73	AVSS	-	Connected to GND.
74	VREF	-	Power supply.
75	I-DRF	I	CD RF level detection input.
76	I-RDS-CLK	I	RDS clock input.
77	O-PLL_CE	O	PLL IC chip enable output.
78	O-PLL_CLK	O	PLL IC clock output.
79	O-DSC/O-PLL DATA	O	Function IC control output / PLL data output.
80	I-TP-SW	I	Cassette deck.

ADJUSTMENT <TUNER / DECK>

A MAIN C.B

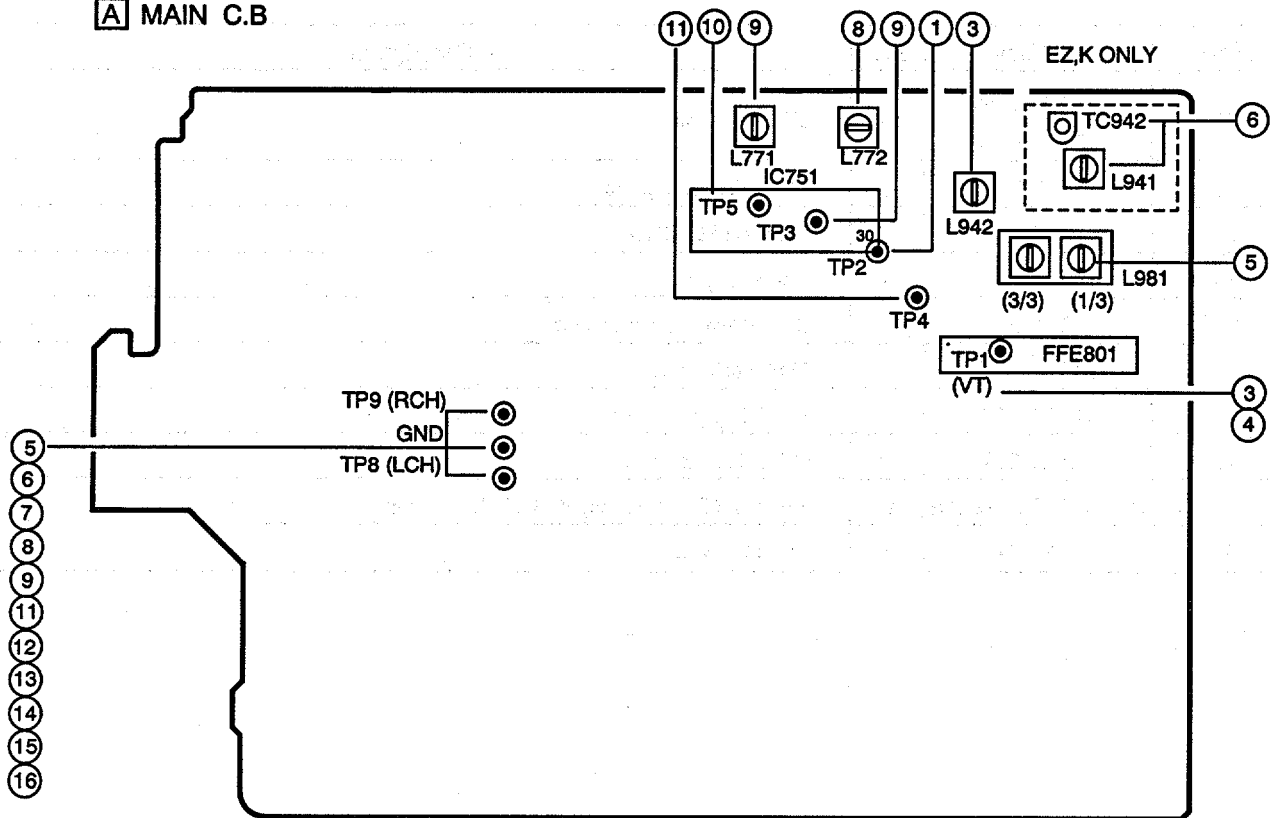

< TUNER SECTION >

1. Clock Frequency Check
 Settings : • Test point : TP2
 Method : Set to AM (MW) 1602kHz (EZ,K,V) / AM 1710kHz (LH) and check that the test point is 2052kHz \pm 45Hz (EZ,K,V) / 2160 kHz \pm 45Hz (LH).
- 2a. MW VT Check <LH>
 Settings : • Test point : TP1 (VT)
 Method : Set to AM 1710kHz and AM 530 kHz and check that the test point is less than 8.5V (1710kHz) and more than 0.6V (530kHz)
- 2b. MW VT Check <EZ,K,V>
 Settings : • Test point : TP1 (VT)
 Method : Set to AM 1602kHz and AM 531 kHz and check that the test point is less than 8.0V (1602kHz) and more than 0.6V (531kHz)
3. LW VT Adjustment <EZ,K>
 Settings : • Test point : TP1 (VT)
 • Adjustment location : L942
 Method : Set to LW 144kHz and adjust L942 so that the test point becomes 1.3V \pm 0.05V. Then check that the test point is less than 8.0V (290kHz).
- 4a. FM VT Check <LH,EZ,K>
 Settings : • Test point : TP1 (VT)
 Method : Set to FM 87.5MHz, 108.0MHz and check that the test point is more than 0.5V (87.5MHz) and less than 8.0V (108.0MHz).
- 4b. FM VT Check <V>
 Settings : • Test point : TP1 (VT)
 Method : Set to FM 65.0MHz, 108.0MHz and check that the test point is more than 1.0V (65.0 MHz) and less than 9.5V (108.0MHz).
5. MW Tracking Adjustment
 Settings : • Test point : TP8(Lch), TP9(Rch)
 • Adjustment location :
 L981(1/3) 999kHz
 Method : Set to AM 999kHz and adjust L981(1/3) to MAX.
6. LW Tracking Adjustment <EZ,K>
 Settings : • Test point : TP8(Lch), TP9(Rch)
 • Adjustment location :
 L941 5.9MHz
 TC942 17.9MHz
 Method : Set up TC942 to center before adjustment. The level at 144kHz is adjust to maximum by L941. Then the level at 290kHz is adjust to maximum by TC942.
7. FM Tracking Check
 Settings : • Test point : TP8(Lch), TP9(Rch)
 Method : Set to FM 98.0MHz and check that the test point is less than 9dB <LH> / 10dB <EZ,K> / 6dB <V>.
8. AM(MW) IF Adjustment
 Settings : • Test point : TP8(Lch), TP9(Rch)
 • Adjustment location :
 L772 450kHz
9. DC Balance / Mono Distortion Adjustment
 Settings : • Test point : TP3, TP4 (DC Balance)
 : TP8(Lch), TP9(Rch) (Distortion)
 • Adjustment location : L771
 • Input level : 54dB
 Method : Set to FM 98.0MHz and adjust L771 so that the voltage between TP3 and TP4 becomes 0V \pm 0.04V. Next, check that the distortion is less than 1.3%.

B FRONT C.B

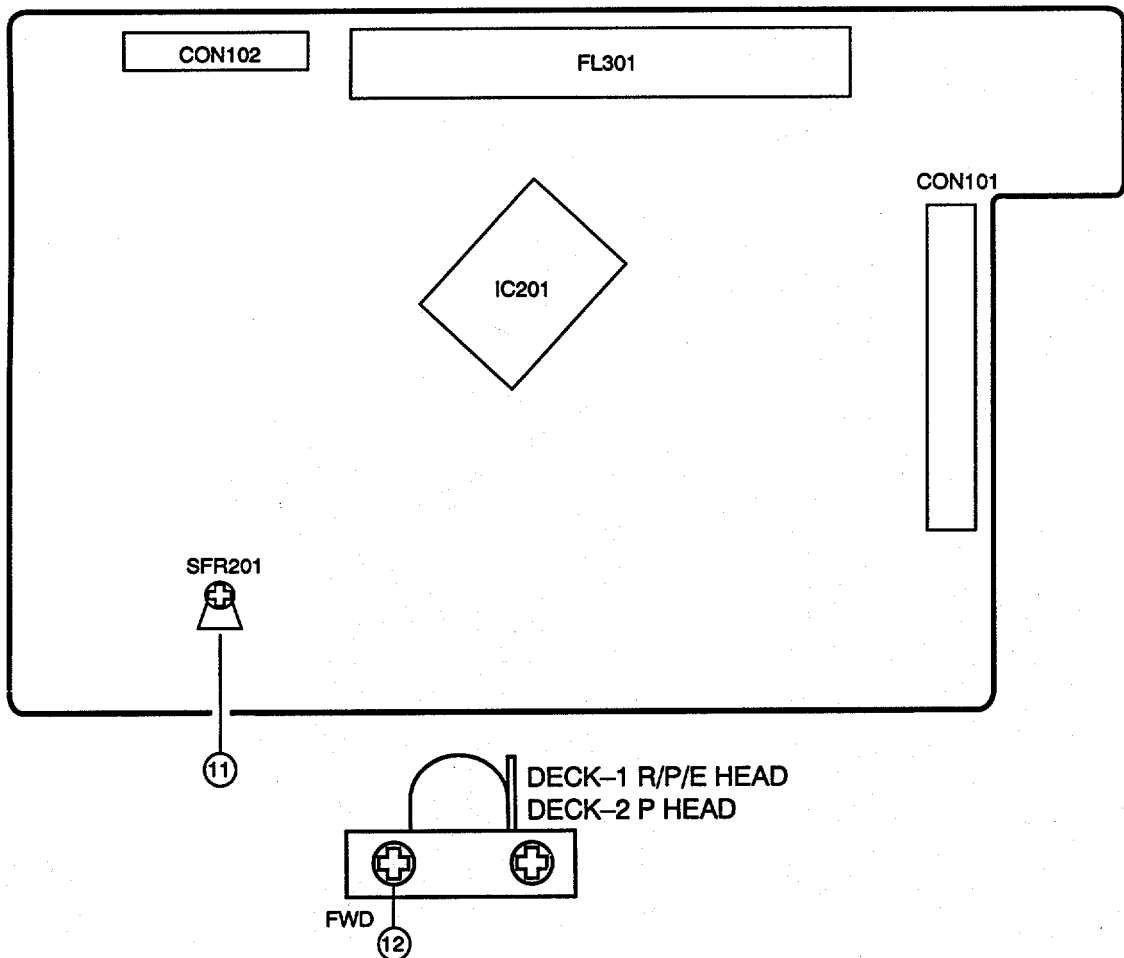

10. Auto Stop Level Check

MW : • Input level : 52dB
• Test point : TP5

Method : Check auto stop at MW 999kHz and the level is 52dB +10dB /-15dB.

FM : • Input level : 25dB
• Test point : TP5

Method : Check auto stop at FM 98.0MHz and the level is 25 dB ± 10 dB.

< DECK SECTION >

11. Tape Speed Adjustment (DECK 1, DECK 2)

Settings : • Test tape : TTA-100
• Test point : TP8(Lch), TP9(Rch)
• Adjustment location : SFR201

Method : Play back the test tape and adjust SFR201 so that the frequency counter reads 3000Hz ± 5Hz.

12. Head Azimuth Adjustment (DECK 1, DECK 2)

Settings : • Test tape : TTA-330
• Test point : TP8(Lch), TP9(Rch)
• Adjustment location : Head azimuth adjustment screw
Method : Play back (FWD) the 8kHz signal of the test tape and adjust screw so that the output becomes maximum.

13. PB Frequency Response Check (DECK 1, DECK 2)

Settings : • Test tape : TTA-330
• Test point : TP8(Lch), TP9(Rch)
Method : Play back the 315Hz and 8kHz signals of the test tape and check that the output ratio of the 8kHz signal with respect to that of the 315Hz signal is within 5dB.

14. PB Sensitivity Check (DECK 1, DECK 2)

Settings : • Test tape : TTA-200
• Test point : TP8(Lch), TP9(Rch)

Method : Play back the test tape and check that the output level of the test point is 110mV ± 3.0dB

15. REC/PB Frequency Response Check (DECK 1)

Settings : • Test tape : TTA-602
• Test point : TP8(Lch), TP9(Rch)
• Input signal : 1kHz / 8kHz (LINE IN)

Method : Apply a 1kHz signal and REC mode. Then adjust OSC attenuator so that the output level at the TP8, TP9 becomes (-20VU) -26dBV. Record and Play back the 1kHz and 8kHz signals so that the output of the 8kHz signal is 0dB +4dB/-6dB.

16. REC/PB Sensitivity Check (DECK 1)

Settings : • Test tape : TTA-602
• Test point : TP8(Lch), TP9(Rch)
• Input signal : 1kHz (LINE IN)

Method : Apply a 1kHz signal and REC mode. Then adjust OSC attenuator so that the output level at TP8, TP9 becomes (0VU) -6dBV. Record and play back the 1kHz and 8kHz signal and check that the output is -2 ± 3.5dB.

PRACTICAL SERVICE FIGURE

<TUNER SECTION>

<FM SECTION>

IHF Sensitivity : Less than 10 / 9 / 9dB (LH)
(THD 3%) (at 87.5 / 98.0 / 108.0MHz)
Less than 11 / 10 / 10dB (EZ,K)
(at 87.5 / 98.0 / 108.0MHz)
Less than 9dB (V)
(at 70.0MHz)

S/N 50dB Quieting sensitivity :

Less than 38dB (EZ,K)
Less than 35dB (LH,V)
(at 98.0MHz)

Signal to noise ratio : Mono : More than 68dB (98.0MHz)
Stereo: More than 66dB (98.0MHz)

Distortion : Mono : Less than 1.2% (98.0MHz)
Stereo: Less than 2.0% (98.0MHz)

Auto stop level : 25dB ± 10dB

Stereo separation : More than 25dB (LH,V)
More than 12dB (EZ,K)
(at 98.0MHz)

Intermediate frequency : 10.7MHz

<LW SECTION> (EZ,K)

Sensitivity : Less than 70dB (at 144kHz)
Less than 66dB (at 198kHz)
Less than 66dB (at 290kHz)

<MW SECTION>

Sensitivity : Less than 60dB (at 603kHz)
Less than 58dB (at 1000kHz)
Less than 58dB (at 1404kHz)
Signal to noise ratio : More than 36dB (at 1000kHz)
Distortion : Less than 1.5% (at 1000kHz)
Auto stop level : 52dB +10dB / -15dB (at 1000kHz)
Intermediate frequency : 450kHz

<DECK SECTION>

Tape speed : 3000Hz ± 45Hz
Wow & flutter : Less than 0.35% (W.R.M.S)
Take-up torque : 30 ~ 60g-cm (FWD)
Back tension : 2 ~ 5g-cm
PB output level : 2.8V ± 3dB
REC/PB output level : 1.8V ± 3dB
Distortion (REC/PB) : Less than 2.0% (NORM)
Noise level (PB) : Less than 30mV (NORM)
Noise level (REC/PB) : Less than 30mV (NORM)
Erasing ratio : More than 60dB (at 125Hz, +10VU)
Test tape : TTA-602 (NORMAL)

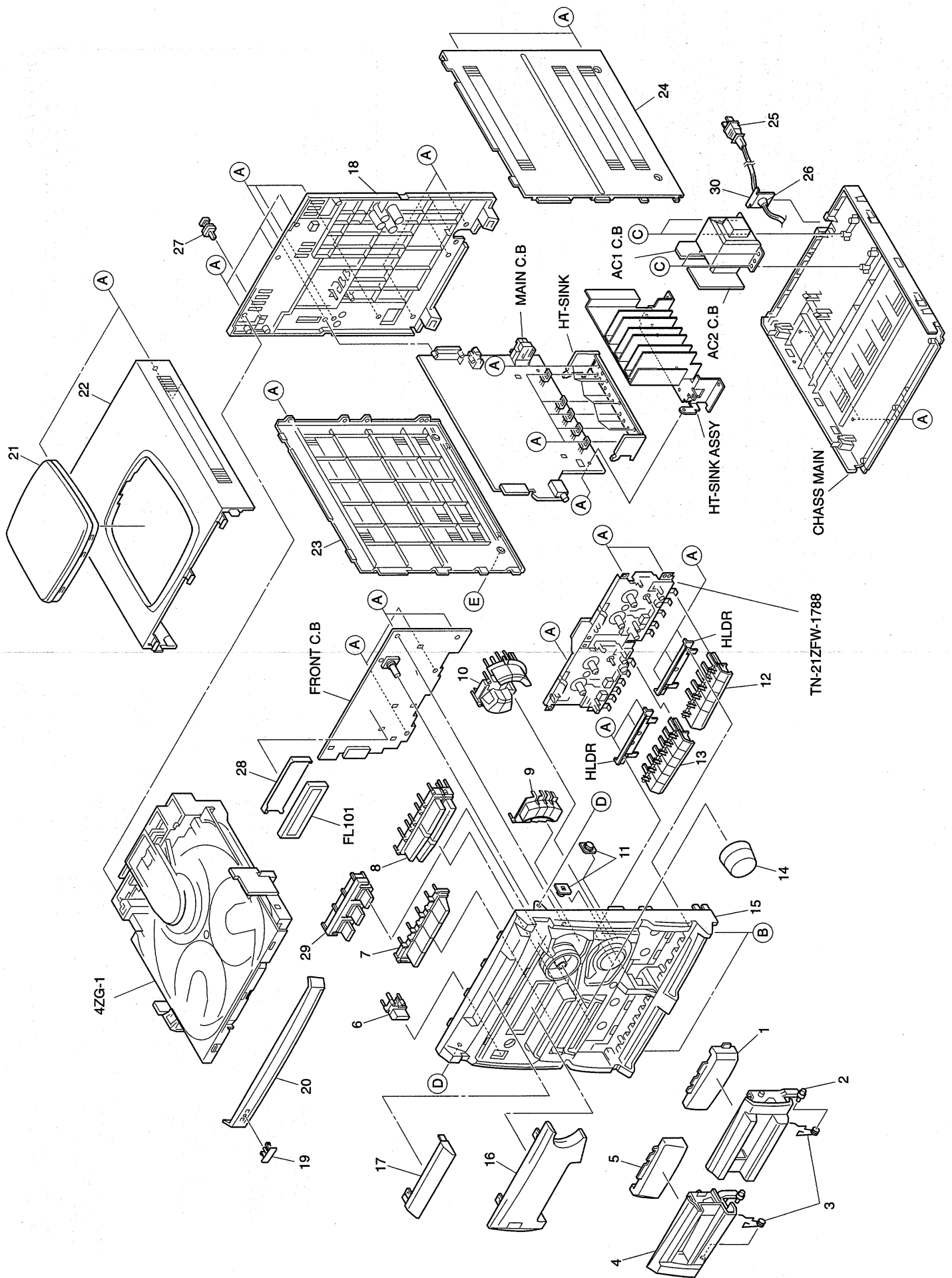

MECHANICAL PARTS LIST 1 / 1

If can't understand for Description please kindly refer to "REFERENCE NAME LIST".

REF. NO.	PART NO.	KANRI NO.	DESCRIPTION	REF. NO.	PART NO.	KANRI NO.	DESCRIPTION
1	88-NF9-014-010		WINDOW,CASS 1	18	88-NF9-046-010		CABI,REAR VJSTNC<V>
2	88-NF9-004-110		BOX,CASS U2	19	82-NE6-067-010		BADGE,AIWA 30N
3	82-NF7-218-010		SPR-T,CASS	20	88-NF9-018-010		PANEL,TRAY
4	88-NF9-003-110		BOX,CASS U1	21	86-NFZ-001-010		WINDOW,TOP
5	88-NF9-015-010		WINDOW,CASS 2	22	87-NF8-045-010		PANEL,TOP ST
6	88-NF9-005-010		KEY,POWER	23	88-NF9-030-010		PANEL,LEFT
7	88-NF9-008-010		KEY,FUN	24	88-NF9-031-010		PANEL,RIGHT<V, LH>
8	88-NF9-011-010		KEY,OPE	24	88-NF9-082-010		PANEL,RIGHT HI<K, EZ>
9	88-NF9-007-010		KEY,GEQ	25	87-A80-007-110		AC CORD ASSY,K BLK<K>
10	88-NF9-006-010		KEY,CD	25	87-050-079-010		AC-CORD ASSY,E<EXCEPT K>
11	86-NFZ-231-010		DMPR,70	26	87-085-185-010		BUSHING, AC CORD (E)
12	88-NF9-009-110		KEY,CASS 1	27	84-2G1-245-210		CAP,OPTICAL
13	88-NF9-010-110		KEY,CASS 2	28	82-NF7-210-110		GUIDE,FL
14	88-NF9-012-010		KNOB,RTRY VOL	29	88-NF9-017-010		KEY,RDS<203EZ>
15	88-NF9-022-010		CABI,FR LH<K,V,202EZ>	30	86-NFZ-204-010		HLDL,BUSHING<V, LH>
15	88-NF9-022-110		CABI,FR LH<LH>	A	87-067-703-010		TAPPING SCREW, BVT2+3-10
15	88-NF9-024-010		CABI,FR RDS<203EZ>	B	87-067-758-010		BVT2+3-12 W/O SLOT<V, LH>
16	88-NF9-038-110		WINDOW,DISP K<K,V,202EZ>	B	87-067-688-010		BVTT+3-6<K, EZ>
16	88-NF9-081-110		WINDOW,DISP LHC1<LH>	C	87-078-019-010		S-SCREW,IT+4-6<K, EZ>
16	88-NF9-037-110		WINDOW,DISP RDS<203EZ>	C	87-741-172-410		UT2+4-12 W/O SLOT<V, LH>
17	88-NF9-016-010		WINDOW,CD	D	87-721-097-410		QT2+3-12 GLD
18	88-NF9-076-010		CABI,REAR EZSTNM<202EZ>	E	87-067-641-010		UTT2+3-8(W/O SLOT)BL
18	88-NF9-077-010		CABI,REAR EZSTNM RDS<203EZ>				
18	88-NF9-045-010		CABI,REAR KSTNC<K>				
18	88-NF9-057-010		CABI,REAR LHJSC1M<LH>				

TAPE MECHANISM EXPLODED VIEW 1 / 2

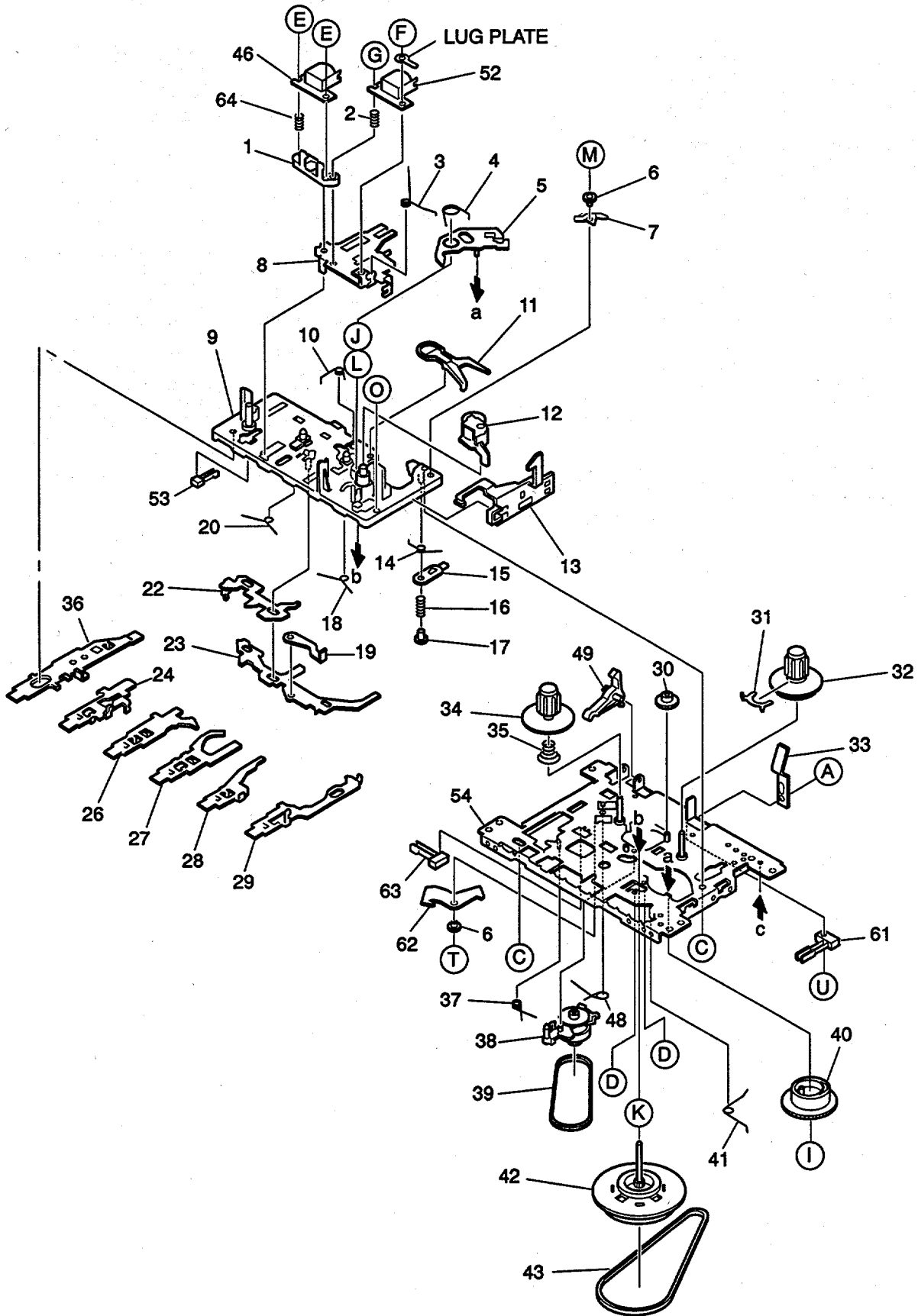

TAPE MECHANISM PARTS LIST 1/2

If can't understand for Description please kindly refer to "REFERENCE NAME LIST".

REF. NO.	PART NO.	KANRI NO.	DESCRIPTION	REF. NO.	PART NO.	KANRI NO.	DESCRIPTION
1	S1-921-030-060		HEAD BASE	38	S1-921-073-080		RF CLUTCH ASSY
2	S1-821-030-070		AZIMUTH SPRING	39	S1-821-070-110		RF BELT
3	S1-921-030-090		PANEL P SPRING	40	S1-921-260-020		CAM GEAR
4	S1-921-260-050		GEAR PLATE SPRING	41	S1-921-140-160		E ACTUATOR SPRING
5	S1-921-265-020		GEAR PLATE ASSY	42	S1-921-093-210		FLYWHEEL ASSY
6	S1-921-140-370		P ARM COLLER	43	S1-921-090-240		MAIN BELT
7	S1-921-140-340		P ARM	46	S6-202-140-190		E,HEAD
8	S1-921-030-140		HEAD PANEL	48	S1-921-140-210		REC BUTTON LEVER SPRING
9	S1-921-143-170		BASE ASSY	49	S1-821-100-690		RECORD SAFETY LEVER
10	S1-921-141-8A0		M CONTROL SPRING	52	S6-202-010-920		R.P HEAD MS15R-AK0N1
11	S1-921-260-4A0		SENSING LEVER	53	S6-401-011-490		LEAF SW MSW-1541T
12	S1-921-043-100		PINCH ROLLER ARM ASSY	54	S1-921-015-010		CHASSIS ASSY
13	S1-921-130-020		EJECT SLIDE LEVER	61	S6-401-010-380		LEAF SWITCH MSW-1275
14	S1-921-141-3A0		P CONTROL SPRING	62	S1-921-020-010		REC ARM
15	S1-921-140-550		PAUSE LEVER(E)	63	S6-401-011-610		LEAF SW MSW-17820MVE1
16	S1-921-140-120		PAUSE LEVER SPRING	64	S1-821-030-080		EH SPRING
17	S1-921-140-110		PAUSE STOPPER	A	S9-P04-200-310		TAPPING SCREW 2-3
18	S1-921-140-150		BUTTON LEVER SPRING(B)	C	S9-B10-200-510		P TAPPING BIND ACREW M2-5
19	S1-921-140-640		E RICK LEVER	D	S9-C07-204-510		SCREW,TAPPING M2-4.5
20	S1-921-140-140		BUTTON LEVER SPRING(A)	E	S9-P17-205-710		+CAP SCREW M2-7.5
22	S1-921-140-090		SWITCH ACTUATOR	F	S9-B01-200-310		+ BIND SCREW M2-3
23	S1-921-140-080		PUSH BUTTON ACTUATOR	G	S9-F08-200-710		AZIMUTH SCREW M2-7
24	S1-921-140-230		PLAY BUTTON LEVER	I	S9-W02-300-100		P WASHER CUT 1.2-3.8-0.3
26	S1-921-140-240		REW BUTTON LEVER	J	S9-W02-500-100		P WASHER CUT 1.45-3.8-0.5
27	S1-921-140-250		FF BUTTON LEVER	K	S9-W01-400-100		P WASHER 2-3.5-0.4
28	S1-921-140-660		STOP BUTTON LEVER	L	S9-W01-130-200		P WASHER 2.1-4-0.13
29	S1-921-140-610		PAUSE BUTTON LEVER	M	S9-P08-203-010		PS TAPPING SCREW M2-5
30	S1-821-100-700		FF GEAR	O	S9-P05-200-610		S TAPPING SCREW M2-6
31	S1-921-050-060		SENSOR	T	S9-P04-200-410		C TAPPING SCREW M2-4
32	S1-921-053-100		TAKE UP REEL ASSY	U	S9-P04-200-510		C TAPPING SCREW M2-5
33	S1-829-100-010		PACK SPRING				
34	S1-921-050-150		S REEL HUB				
35	S1-921-050-220		BACK TENSION SPRING				
36	S1-921-140-220		REC BUTTON LEVER				
37	S1-921-140-170		P.S.LEVER SPRING				

TAPE MECHANISM EXPLODED VIEW 2/2

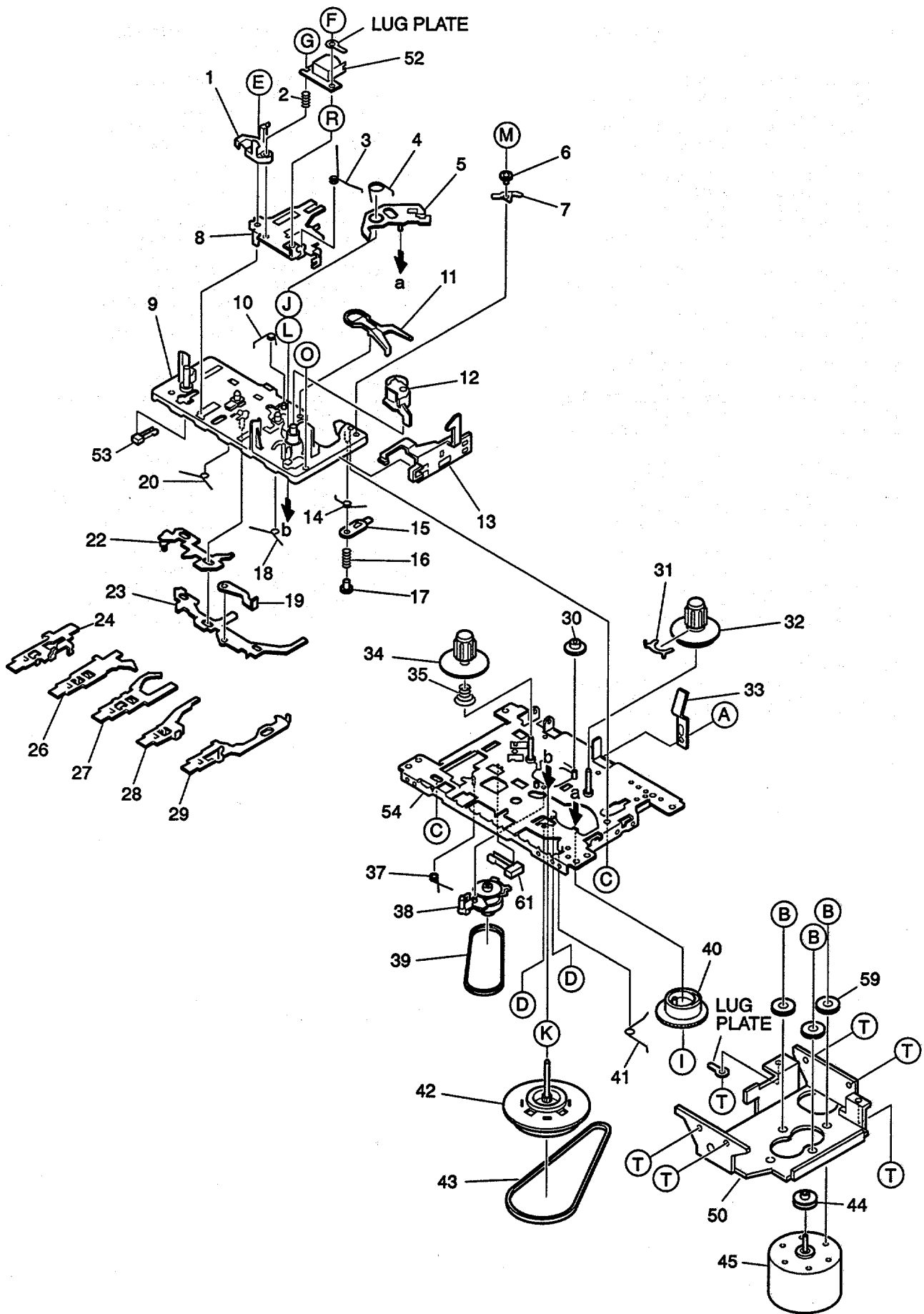

TAPE MECHANISM PARTS LIST 2/2

If can't understand for Description please kindly refer to "REFERENCE NAME LIST".

REF. NO.	PART NO.	KANRI NO.	DESCRIPTION	REF. NO.	PART NO.	KANRI NO.	DESCRIPTION
1	S1-921-030-4A0		HEAD BASE	39	S1-821-070-110		RF BELT
2	S1-821-030-070		AZIMUTH SPRING	40	S1-921-260-020		CAM GEAR
3	S1-921-030-090		PANEL P SPRING	41	S1-921-140-160		E ACTUATOR SPRING
4	S1-921-260-050		GEAR PLATE SPRING	42	S1-921-093-240		FLYWHEEL ASSY
5	S1-921-265-020		GEAR PLATE ASSY	43	S1-921-090-240		MAIN BBELT
6	S1-921-140-370		P ARM COLLER	44	S1-921-120-130		MOTOR PULLEY
7	S1-921-140-340		P ARM	45	S6-002-030-290		MOTOR EG530YD-2BH
8	S1-921-030-110		HEAD PANEL	50	S1-921-120-110		MOTOR BRACKET
9	S1-921-143-010		BASE ASSY	52	S6-202-010-920		R.P HEAD MS15R-AK0N1
10	S1-921-141-8A0		M CONTROL SPRING	53	S6-401-011-490		LEAF SW MSW-1541T
11	S1-921-260-4A0		SENSING LEVER	54	S1-921-015-010		CHASSIS ASSY
12	S1-921-043-100		PINCH ROLLER ARM ASSY	59	S1-820-130-060		MOTOR RUBBER
13	S1-921-130-020		EJECT SLIDE LEVER	61	S6-401-011-610		LEAF SW MSW-17820MVE1
14	S1-921-141-3A0		P CONTROL SPRING	A	S9-P04-200-310		TAPPING SCREW 2-3
15	S1-921-140-550		PAUSE LEVER(E)	B	S1-821-120-020		MOTOR COLLER SCREW
16	S1-921-140-120		PAUSE LEVER SPRING	C	S9-B10-200-510		P TAPPING BIND ACREW M2-5
17	S1-921-140-110		PAUSE STOPPER	D	S9-C07-204-510		SCREW,TAPPING M2-4.5
18	S1-921-140-150		BUTTON LEVER SPRING(B)	E	S9-P01-200-610		SCREW M2-6
19	S1-821-011-590		E KICK LEVER	F	S9-B01-200-310		+ BIND SCREW M2-3
20	S1-921-140-140		BUTTON LEVER SPRING(A)	G	S9-P08-200-710		AZIMUTH SCREW M2-7
22	S1-921-140-090		SWITCH ACTUATOR	I	S9-W02-300-100		P WASHER CUT 1.2-3.8-0.3
23	S1-921-140-080		PUSH BUTTON ACTUATOR	J	S9-W02-500-100		P WASHER CUT 1.45-3.8-0.5
24	S1-921-140-230		PLAY BUTTON LEVER	K	S9-W01-400-100		P WASHER 2-3.5-0.4
26	S1-921-140-240		REW BUTTON LEVER	L	S9-W01-130-200		P WASHER 2.1-4-0.13
27	S1-921-140-250		FF BUTTON LEVER	M	S9-P08-203-010		PS TAPPING SCREW M2-5
28	S1-921-140-260		STOP BUTTON LEVER	O	S9-P05-200-610		S TAPPING SCREW M2-6
29	S1-921-140-610		PAUSE BUTTON LEVER	T	S9-P04-200-410		C TAPPING SCREW M2-4
30	S1-821-100-700		FF GEAR				
31	S1-921-050-060		SENER				
32	S1-921-053-100		TAKE UP REEL ASSY				
33	S1-829-100-010		PACK SPRING				
34	S1-921-050-150		S REEL HUB				
35	S1-921-050-220		BACK TENSION SPRING				
37	S1-921-140-170		P.S.LEVER SPRING				
38	S1-921-073-080		RF CLUTCH ASSY				

SPEAKER DISASSEMBLY INSTRUCTIONS

Type.1

Insert a flat-bladed screwdriver into the position indicated by the arrows and remove the panel. Remove the screws of each speaker unit and then remove the speaker units.

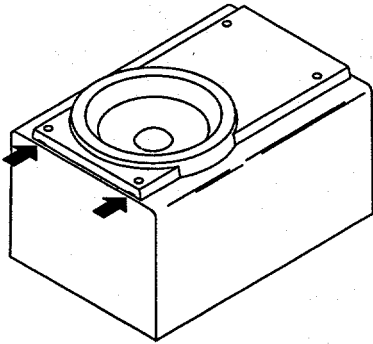

Type.2

Remove the grill frame and four pieces of rubber caps by pulling out with a flat-bladed screwdriver. Remove the screws from hole where installed rubber caps. Insert a flat-bladed screwdriver into the position indicated by the arrows and remove the panel. Remove the screws of each speaker unit and then remove the speaker units.

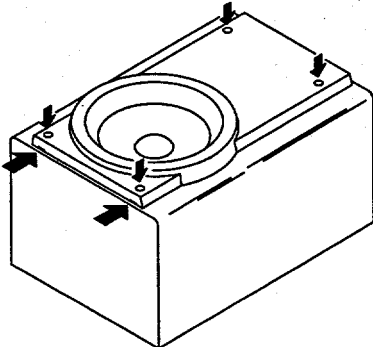

Type.3

Insert a flat-bladed screwdriver into the position indicated by the arrows and remove the panel. Turn the speaker unit to counter-clockwise direction while inserting a flat-bladed screwdriver into one of the hollows around speaker unit, and then remove the speaker unit. After replacing the speaker unit, install it turning to clockwise direction until "click" sound comes out.

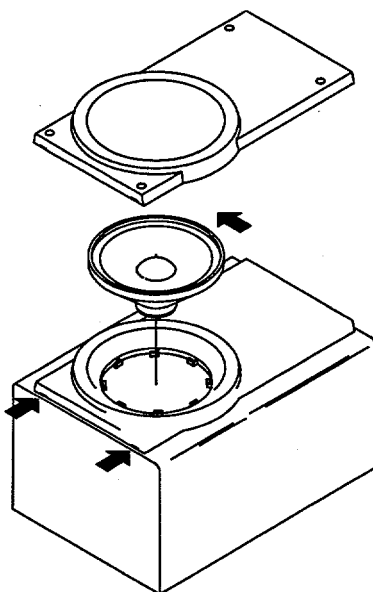

Type.4

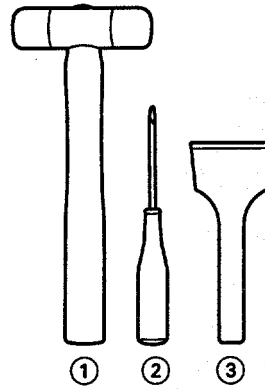

TOOLS

- ① Plastic head hammer
- ② (⊖) flat head screwdriver
- ③ Cut chisel

How to Remove the PANEL, FR

1. Insert the (⊖) flat head screwdriver tip into the gap between the PANEL, FR and the PANEL, SPKR. Tap the head of the (⊖) flat head screwdriver with the plastic hammer head, and create the clearance as shown in Fig-1.
2. Insert the cut chisel in the clearance, and tap the head of the cut chisel with plastic hammer as shown in Fig-2, to remove the PANEL, FR.
3. Place the speaker horizontally. Tap head of the cut chisel with plastic hammer as shown in Fig-3, and remove the PANEL, FR completely.

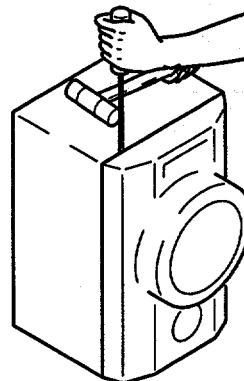

Fig-1

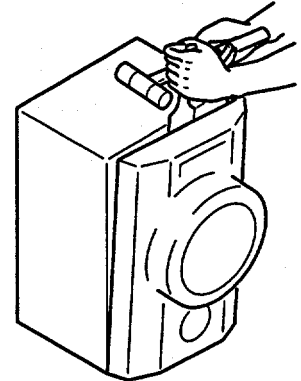

Fig-2

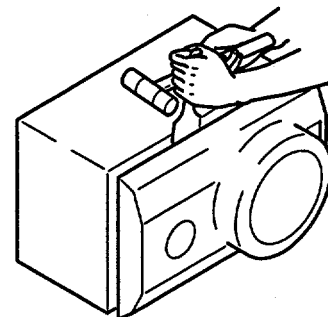

Fig-3

How to Attach the PANEL, FR

Attach the PANEL, FR to the PANEL, SPKR. Tap the four corners of the PANEL, FR with the plastic hammer to fit the PANEL, FR into the PANEL, SPKR completely.

SPEAKER PARTS LIST

(SX-NS202 <YSTNL,YSTNC,YJSTNC,YSTNYI,YSTNY2>)

(SX-SNS202 <YLJSCM>)

If can't understand for Description please kindly refer to "REFERENCE NAME LIST".

REF. NO.	PART NO.	KANRI NO.	DESCRIPTION
1	87-NS7-611-010		CORD, SPKR
2	88-NSK-001-010		PANEL, FR
3	88-NSK-002-010		PANEL, BA
4	88-NSK-610-010		SPKR, CERAMIC ASSY
5	88-NSK-601-110		SPKR, W 120<YSTNC,YSTNL>
5	88-NSK-603-110		SPKR, W 120<YJSTNC,YLJSCM>
5	88-NSK-604-010		SPKR, W 120<YSTNY1,YSTNY2>

REFERENCE NAME LIST

ELECTRICAL SECTION

DESCRIPTION	REFERENCE NAME
ANT	ANTENNAS
C-	CHIP
C-CAP	CAP, CHIP
C-CAP TN	CAP, CHIP TANTALUM
C-COIL	COIL, CHIP
C-DI	DIODE, CHIP
C-DIODE	DIODE, CHIP
C-FET	FET, CHIP
C-FOTR	FILTER, CHIP
C-JACK	JACK, CHIP
C-LED	LED, CHIP
C-RES	RES, CHIP
C-SFR	SFR, CHIP
C-SLIDE SW	SLIDE SWITCH, CHIP
C-SW	SWITCH, CHIP
C-TR	TRANSISTOR, CHIP
C-VR	VOLUME, CHIP
C-ZENER	ZENER, CHIP
CAP, CER	CAP, CERA-SOL
CAP, E	CAP, ELECT
CAP, M/F	CAP, FILM
CAP, TC	CAP, CERA-SOL
CAP, TC-U	CAP, CERA-SOL SS
CAP, TN	CAP, TANTALUM
CERA FIL	FILTER, CERAMIC
CF	FILTER, CERAMIC
DL	DELAY LINE
E/CAP	CAP, ELECT
FILT	FILTER
FLTR	FILTER
FUSE RES	RES, FUSE
MOT	MOTOR
P-DIODE	PHOTO DIODE
P-SNSR	PHOTO SENSER
P-TR	PHOTO TRANSISTOR
POLY VARI	VARIABLE CAPACITOR
PPCAP	CAP, PP
PT	POWER TRANSFORMER
PTR, RES	PTR, MELF
RC	REMOTE CONTROLLER
RES NF	RES, NON-FLAMMABLE
RESO	RESONATOR
SHLD	SHIELD
SOL	SOLENOID
SPKR	SPEAKER
SW, LVR	SWITCH, LEVER
SW, RTRY	SWITCH, ROTARY
SW, SL	SWITCH, SLIDE
TC CAP	CAP, CERA-SOL
THMS	THERMISTOR
TR	TRANSISTOR
TRIMER	CAP, TRIMMER
TUN-CAP	VARIABLE CAPACITOR
VIB, CER	RESONATOR, CERAMIC
VIB, XTAL	RESONATOR, CRYSTAL
VR	VOLUME
ZENER	DIODE, ZENER

MECHANICAL SECTION

DESCRIPTION	REFERENCE NAME
ADHESHIVE	SHEET ADHESHIVE
AZ	AZIMUTH
BAR-ANT	BAR-ANTENNA
BAT	BATTERY
BATT	BATTERY
BRG	BEARING
BTN	BUTTON
CAB	CABINET
CASS	CASSETTE
CHAS	CHASSIS
CLR	COLLAR
CONT	CONTROL
CRSR	CURSOR
CU	CUSHION
CUSH	CUSHION
DIR	DIRECTION
DUBB	DUBBING
FL	FRONT LOADING
FLY-WHL	FLYWHEEL
FR	FRONT
FUN	FUNCTION
G-CU	G-CUSHION
HDL	HANDOL
HIMERON	CLOTH
HINGE, BAT	HINGE, BATTERY
HLDR	HOLDER
HT-SINK	HEAT SINK
IB	INSTRUCTION BOOKLET
IDLE	IDLER
IND, L-R	INDICATOR, L-R
KEY, CONT	KEY, CONTROL
KEY, PRGM	KEY, PROGRAM
KNOB, SL	KNOB, SLIDE
LBL	LABEL
LID, BATT	LID, BATTERY
LID, CASS	LID, CASSETTE
LVR	LEVER
P-SP	P-SPRING
PANEL, CONT	PANEL, CONTROL
PANEL, FR	PANEL, FRONT
PRGM	PROGRAM
PULLY, LOAD MO	PULLY, LOAD MOTOR
RBN	RIBBON
S-	SPECIAL
SEG	SEGMENT
SH	SHEET
SHLD-SH	SHIELD-SHEET
SL	SLIDE
SP	SPRING
SP-SCREW	SPECIAL-SCREW
SPACER, BAT	SPACER, BATTERY
SPR	SPRING
SPR-P	P-SPRING
SPR-PC-PUSH	P-SPRING, C-PUSH
T-SP	T-SPRING
TERM	TERMINAL
TRIG	TRIGGER
TUN	TUNING
VOL	VOLUME
W	WASHER
WHL	WHEEL
WORM-WHL	WORM-WHEEL

サービス技術ニュース	
番号	連絡内容
G-	-
G-	-
G-	-

アイワ株式会社
AIWA CO., LTD.

9820543, 912204, 931261

Tokyo Japan