

aiwa

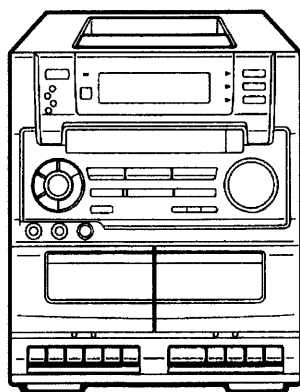

NSX-S4



CD CARRY COMPONENT SYSTEM

- BASIC TAPE MECHANISM: TN-21ZSW-1691
- BASIC CD MECHANISM: 3ZG-3 A6N

•TYPE: HEJ

REVISION PUBLISHING

This Service Manual is the "Revision Publishing" and replaces "Simple Manual" (S/M Code No. 09-97A-226-70T).

MANUAL
SERVICE

TABLE OF CONTENTS

SPECIFICATIONS	3
PROTECTION OF EYES FROM LASER BEAM DURING SERVICING/ Precaution to replace Optical block.....	4
ELECTRICAL MAIN PARTS LIST	5-7
TRANSISTOR ILLUSTRATION	7
LCD DISPLAY	8
BLOCK DIAGRAM-1 (MAIN).....	9, 10
BLOCK DIAGRAM-2 (TUNER)	11
BLOCK DIAGRAM-3 (CD)	12, 13
SCHEMATIC DIAGRAM-1 (MAIN).....	14-16
WIRING-1 (MAIN)	17, 18
WIRING-2 (FRONT)	19, 20
SCHEMATIC DIAGRAM-2 (FRONT)	21, 22
WIRING-3 (CD)	23, 24
SCHEMATIC DIAGRAM-3 (CD)	25, 26
VOLTAGE CHART	27-29
IC DESCRIPTION	30-36
IC BLOCK DIAGRAM.....	37-41
ELECTRICAL ADJUSTMENT	42-45
PRACTICAL SERVICE FIGURE.....	46
MECHANICAL EXPLODED VIEW 1/1	47, 48
MECHANICAL PARTS LIST 1/1	49
TAPE MECHANISM EXPLODED VIEW 1/2	50
TAPE MECHANISM PARTS LIST 1/2	51
TAPE MECHANISM EXPLODED VIEW 2/2	52
TAPE MECHANISM PARTS LIST 2/2	53
CD MECHANISM EXPLODED VIEW 1/2	54
CD MECHANISM PARTS LIST 1/2	55
CD MECHANISM EXPLODED VIEW 2/2	56
CD MECHANISM PARTS LIST 2/2	56
SPEAKER EXPLODED VIEW, PARTS LIST 1/1	57, 58
ACCESSORIES/PACKAGE LIST	59
REFERENCE NAME LIST	60

SPECIFICATIONS

Tuner section

FM

87.5 - 108.0 MHz
Antenna: Rod antenna

MW

531/530 - 1602/ 1710 kHz (9/10 kHz)
Antenna: Ferrite bar antenna

SW

3.8 - 12.5 MHz
Antenna: Ferrite bar antenna

Amplifier section

Power output

10 W+10 W (4 ohms, EIAJ)

Power requirements

DC 12 V using eight size D (R20)
batteries

AC 110-120 V/220-240 V
selectable, 50/60 Hz

Power consumption

45 W

CD player section

Disc

Compact disc

Scanning method

Non-contact optical laser
(semiconductor laser application)

Laser

Semiconductor laser
 $\lambda = 780 \text{ nm}$

Rotation speed

Approx. 500 - 200 rpm/CLV

Error correction

Cross Interleave, Reed Solomon code

Number of channels

2 channels

D/A conversion

1-bit dual

Cassette deck section

Track format

4 tracks, 2 channels

Frequency response

Normal tape: 50-12000 Hz (EIAJ)

Recording system

AC bias

Erasure system

Magnet erase

Motor

DC motor (1)

Heads

Deck 1

Recording/playback head (1)

Erasure head (1)

Deck 2

Playback head (1)

Common section

Dimensions (W × H × D)

266 × 303.7 × 274.1 mm
(10¹/₂ × 12 × 10⁷/₈ in.)

Weight

5.0 kg not including batteries

Speaker

Cabinet type

2-way bass reflex type

Speaker

120 mm (4³/₄ in.) cone type woofer

27 mm (1¹/₈ in.) ceramic type tweeter

Impedance

4 ohms

Allowable max. input

10 W

Dimensions (W × H × D)

200 × 303.7 × 236.5 mm
(8 × 12 × 9³/₈ in.)

Weight

1.75 kg (3 lbs 14 oz)

- Design and specifications are subject to change without notice.

PROTECTION OF EYES FROM LASER BEAM DURING SERVICING

This set employs laser. Therefore, be sure to follow carefully the instructions below when servicing.

WARNING!

WHEN SERVICING, DO NOT APPROACH THE LASER EXIT WITH THE EYE TOO CLOSELY. IN CASE IT IS NECESSARY TO CONFIRM LASER BEAM EMISSION. BE SURE TO OBSERVE FROM A DISTANCE OF MORE THAN 30cm FROM THE SURFACE OF THE OBJECTIVE LENS ON THE OPTICAL PICK-UP BLOCK.

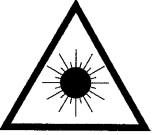

- Caution: Invisible laser radiation when open and interlocks defeated avoid exposure to beam.
- Advarsel: Usynlig laserstråling ved åbning, når sikkerhedsafbrydere er ude af funktion. Undgå udsættelse for stråling.

VAROITUS!

Laiteen Käyttäminen muulla kuin tässä käyttöohjeessa mainitulla tavalla saattaa altistaa käyttäjän turvallisuusluokan 1 ylitävälle näkymättömälle lasersäteilylle.

WARNING!

Om apparaten används på annat sätt än vad som specificeras i denna bruksanvisning, kan användaren utsättas för osynlig laserstråling, som överskrider gränsen för laserklass 1.

CAUTION

Use of controls or adjustments or performance of procedures other than those specified herein may result in hazardous radiation exposure.

ATTENTION

L'utilisation de commandes, réglages ou procédures autres que ceux spécifiés peut entraîner une dangereuse exposition aux radiations.

ADVARSEL!

Usynlig laserstråling ved åbning, når sikkerhedsafbrydere er ude af funktion. Undgå udsættelse for stråling.

This Compact Disc player is classified as a CLASS 1 LASER product.

The CLASS 1 LASER PRODUCT label is located on the rear exterior.

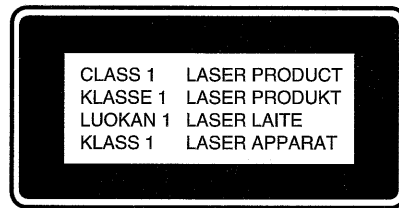

Precaution to replace Optical block (KSS-212A)

Body or clothes electrostatic potential could ruin laser diode in the optical block. Be sure ground body and workbench, and use care the clothes do not touch the diode.

- 1) After the connection, remove solder shown in the right figure.

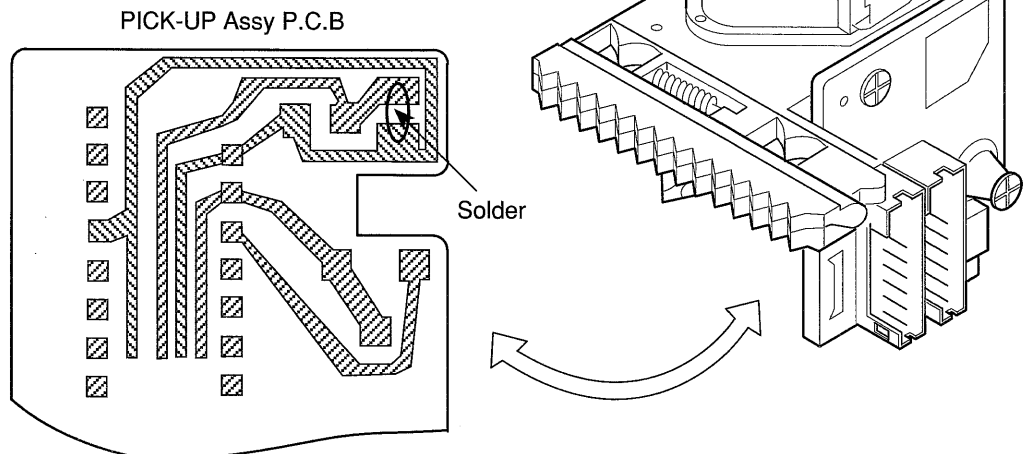

ELECTRICAL MAIN PARTS LIST

DESCRIPTIONで判断できない物は "REFERENCE NAME LIST" を参照してください。
 If can't understand for Description please kindly refer to "REFERENCE NAME LIST".

REF. NO	PART NO.	KANRI NO.	DESCRIPTION	REF. NO	PART NO.	KANRI NO.	DESCRIPTION
IC				C116	87-010-037-010		CAP, E 10-50V
	87-001-440-010	IC, BA15218N		C131	87-010-545-010		CAP, E 0.22-50V
	87-020-828-010	IC, BA3416BL		C132	87-010-221-010		CAP, E 470-10V
	87-070-282-010	IC, BU2092		C142	87-010-221-010		CAP, E 470-10V
	87-017-804-010	IC, BU4052BC		C160	87-010-263-080		ELECT CAP 100-10V
	87-002-444-010	IC, BU4094B		C167	87-010-403-010		CAP, E 3.3-50V
	87-070-083-010	IC, GP1U281X		C194	87-010-263-080		ELECT CAP 100-10V
△	87-002-330-080	IC, ICP-N5		C195	87-010-380-010		CAP, E 47-16V
	87-002-268-010	IC, LA1851N		C305	87-010-380-010		CAP, E 47-16V
	87-001-376-010	IC, LC7218		C306	87-010-380-010		CAP, E 47-16V
	87-017-564-010	IC, LC7533		C307	87-010-038-010		CAP, E 22-25V
	87-CT4-601-010	IC, LC867120W-5F52		C308	87-010-037-010		CAP, E 10-50V
	SI-NS7-805-00C	IC, LM7805		C309	87-010-545-010		CAP, E 0.22-50V
	87-017-787-010	IC, M62412P		C310	87-010-545-010		CAP, E 0.22-50V
	87-027-235-010	IC, NJM4558DD		C311	87-010-248-080		ELECT CAP 220-10V
	87-001-596-010	IC, NJM4580L		C312	87-010-380-010		CAP, E 47-16V
	87-070-416-010	IC, NJU7201L55		C315	87-010-053-810		CAP, E 1-50V
	87-017-801-080	IC, TA2058F		C316	87-010-053-810		CAP, E 1-50V
	87-070-134-010	IC, TA2065F		C317	87-010-038-010		CAP, E 22-25V
	87-001-982-010	IC, TA7291S		C318	87-010-038-010		CAP, E 22-25V
	87-070-308-010	IC, TA8205AH		C319	87-010-037-010		CAP, E 10-50V
	87-017-681-010	IC, TA8126SN		C320	87-010-037-010		CAP, E 10-50V
	87-017-680-010	IC, TA8176SN		C327	87-010-404-010		CAP, E 4.7-50V
	87-070-101-010	IC, TC9284AF		C331	87-010-380-010		CAP, E 47-16V
				C351	87-010-053-810		CAP, E 1-50V
TRANSISTOR				C501	87-010-053-810		CAP, E 1-50V
	89-110-155-010	TR, 2SA1015-GR		C502	87-010-053-810		CAP, E 1-50V
	89-112-964-010	TR, 2SA1296GR		C503	87-010-053-810		CAP, E 1-50V
	89-113-187-080	TR, 2SA1318T/U		C504	87-010-053-810		CAP, E 1-50V
	87-026-463-010	TR, 2SA933S		C505	87-010-263-080		ELECT CAP 100-10V
	89-109-521-210	TR, 2SA952/K/L		C531	87-010-053-810		CAP, E 1-50V
	89-213-702-010	TR, 2SB1370E/F		C532	87-010-053-810		CAP, E 1-50V
	87-026-447-080	TR, 2SC1740S		C539	87-010-545-010		CAP, E 0.22-50V
	89-318-154-010	TR, 2SC1815-BL		C540	87-010-545-010		CAP, E 0.22-50V
	86-NFZ-657-080	TR, 2SC1923 (O)		C541	87-010-260-080		CAP, E 47-25V
	89-320-011-210	TR, 2SC2001/K		C571	87-010-053-810		CAP, E 1-50V
	89-322-405-080	TR, 2SC2240GR		C572	87-010-053-810		CAP, E 1-50V
	89-414-680-080	TR, 2SD1468S		C573	87-010-053-810		CAP, E 1-50V
	89-501-615-080	TR, 2SK161		C574	87-010-053-810		CAP, E 1-50V
	89-502-464-010	TR, 2SK246Y		C579	87-010-380-010		CAP, E 47-16V
	87-026-572-080	TR, DTA114TS		C580	87-010-053-810		CAP, E 1-50V
	87-026-286-010	TR, DTA143ES		C581	87-010-544-010		CAP, E 0.1-50V
	87-026-486-010	TR, DTA144TS		C582	87-010-371-040		CAP, E 470-6.3V
	87-026-464-010	TR, DTC114TS		C583	87-010-263-080		ELECT CAP 100-10V
	87-026-291-010	TR, DTC124XS		C591	87-010-053-810		CAP, E 1-50V
	87-026-287-010	TR, DTC143ES		C592	87-010-053-810		CAP, E 1-50V
	87-026-357-080	TR, DTC343TK		C601	87-015-698-080		CAP, E 4.7-50V
				C602	87-015-698-080		CAP, E 4.7-50V
				C605	87-010-265-010		CAP, E 33-16V
				C606	87-010-265-010		CAP, E 33-16V
DIODE				C607	87-010-037-010		CAP, E 10-50V
	87-020-465-010	DIODE, 1SS133		C608	87-010-037-010		CAP, E 10-50V
	87-001-783-080	DIODE, IN-4002		C611	87-010-260-080		CAP, E 47-25V
	82-135-799-010	DIODE, IN4148		C612	87-010-248-080		ELECT CAP 220-10V
	S0-200-400-000	RECTIFIER BRIDGE 40C-K10		C619	87-010-545-010		CAP, E 0.22-50V
	S3-MTZ-J15-A10	ZENER, MTZJ15A		C620	87-010-545-010		CAP, E 0.22-50V
	S0-100-821-210	ZENER, UJZJ8-2B		C621	87-010-545-010		CAP, E 0.22-50V
	87-001-913-080	ZENER, UTZJ5.6B		C622	87-010-545-010		CAP, E 0.22-50V
				C623	87-010-037-010		CAP, E 10-50V
				C624	87-010-037-010		CAP, E 10-50V
MAIN C.B				C628	87-010-037-010		CAP, E 10-50V
C64	87-010-544-010	CAP, E 0.1-50V		C629	87-010-037-010		CAP, E 10-50V
C103	87-010-248-080	ELECT CAP 220-10V		C720	87-010-037-010		CAP, E 10-50V
C104	87-010-035-010	CAP, E 2.2-50V		C721	87-010-780-410		CAP, E 6800-25V
C108	87-010-053-810	CAP, E 1-50V		C722	87-010-385-010		CAP, E 220-25V
C109	87-010-053-810	CAP, E 1-50V		C723	87-010-248-080		ELECT CAP 220-10V
C110	87-010-053-810	CAP, E 1-50V		C726	87-010-404-010		CAP, E 4.7-50V
C111	87-010-546-080	CAP, E 0.33-50V		C727	87-010-053-810		CAP, E 1-50V
C113	87-010-404-010	CAP, E 4.7-50V		C728	87-010-221-010		CAP, E 470-10V
				C729	87-010-263-080		ELECT CAP 100-10V

REF. NO	PART NO.	KANRI NO.	DESCRIPTION	REF. NO	PART NO.	KANRI NO.	DESCRIPTION
C730	87-010-248-080		ELECT CAP 220-10V	D29	87-017-719-010		LED GL3EG8 3MM(GRN)
C741	87-010-045-010		CAP, E 100-25V	D30	87-017-719-010		LED GL3EG8 3MM(GRN)
C831	87-010-037-010		CAP, E 10-50V	D33	87-017-719-010		LED GL3EG8 3MM(GRN)
C832	87-010-053-810		CAP, E 1-50V	D34	87-017-719-010		LED GL3EG8 3MM(GRN)
CF1	S0-001-070-000		CER, FIL SFE-10.7MA5-M	D35	87-017-719-010		LED GL3EG8 3MM(GRN)
CF101	S0-001-070-000		CER, FIL SFE-10.7MA5-M	D36	87-017-719-010		LED GL3EG8 3MM(GRN)
CT51	S2-101-690-000		TRIMMER TZ03T110FR169	J1	S0-515-460-000		JACK, MIC 3.5MM
CT52	S2-101-690-000		TRIMMER TZ03T110FR169	L10	87-005-647-080		COIL, 10UH
IFT101	S0-029-200-070		IFT, 292MCAS-A617HM	L11	87-005-647-080		COIL, 10UH
J601	S0-020-003-500		JACK, HP 3.5MM	L401	S0-100-262-000		INDUCTOR, 1UH
J602	S0-003-240-000		TERMINAL, 4P	LCD1	S1-120-040-350		LCD, AIW4035T-30P
J801	S0-002-420-000		JACK, RCAHSP-242V-05	SW1	87-036-170-080		SW, TACT
L4	87-003-098-080		INDUCTOR, 2.2UH	SW2	87-036-170-080		SW, TACT
L51	S0-091-310-070		I. F. T. PA7BRS-A9131CCG	SW3	87-036-170-080		SW, TACT
L52	S0-091-330-070		I. F. T. PA119ANS-A9133G0	SW4	87-036-170-080		SW, TACT
L61	S0-611-441-200		COIL, ANT MW	SW5	87-036-170-080		SW, TACT
L62	S0-090-311-200		COIL, ANT SW	SW7	87-036-170-080		SW, TACT
L151	87-003-143-010		INDUCTOR, 4.7UH	SW8	87-036-170-080		SW, TACT
L152	87-005-440-080		INDUCTOR, 47UH	SW9	87-036-170-080		SW, TACT
L191	S0-091-340-070		I. F. T. A7BRCS-A9134	SW10	87-036-170-080		SW, TACT
L192	87-005-696-080		INDUCTOR, 100UH	SW11	87-036-170-080		SW, TACT
L301	S0-091-300-070		I. F. T. 126ANS-A9130YWD	SW12	87-036-170-080		SW, TACT
L601	87-003-097-010		COIL, 1UH	SW13	87-036-170-080		SW, TACT
L602	87-003-097-010		COIL, 1UH	SW14	87-036-170-080		SW, TACT
L603	87-003-097-010		COIL, 1UH	SW15	87-036-170-080		SW, TACT
L604	87-003-097-010		COIL, 1UH	SW16	87-036-170-080		SW, TACT
MFT101	S0-006-600-070		I. F. T. PCFMT-066	SW17	87-036-170-080		SW, TACT
SFR751	S2-020-650-000		SFR, 2K	SW18	87-036-170-080		SW, TACT
SW301	S0-062-200-010		SW, RECORDING	SW19	87-036-170-080		SW, TACT
VC1	87-002-730-010		DIODE, SVC203SPA	SW20	87-036-170-080		SW, TACT
VC2	87-002-730-010		DIODE, SVC203SPA	SW21	87-036-170-080		SW, TACT
VC3	87-002-730-010		DIODE, SVC203SPA	VR401	SE-111-032-010		RES, VARIABLE 10KA
VC51	81-754-634-010		CAP, VARI KV1260TS2	X1	S3-327-680-000		X, TAL 32.768KHZ
VC52	81-754-634-010		CAP, VARI KV1260TS2	X2	87-030-214-080		RESONATOR KBR-6
X101	87-030-218-010		CER, RESO KBR457HS15				
X151	S6-072-000-000		X'TAL 7.2 MHz	CD C. B			
FRONT C.B				C4	87-010-380-010		CAP, E 47-16V
C7	87-010-400-010		CAP, E 0.47-50V	C5	87-010-380-010		CAP, E 47-16V
C8	87-010-053-810		CAP, E 1-50V	C6	87-010-263-080		ELECT CAP 100-10V
C10	87-010-075-040		CAP, E 10-16V	C9	87-010-037-010		CAP, E 10-50V
C12	87-010-079-010		CAP, E 100-6.3V	C10	87-010-380-010		CAP, E 47-16V
C18	87-010-908-010		CAP, E 220-10V	C13	87-010-037-010		CAP, E 10-50V
C98	87-010-263-080		ELECT CAP 100-10V	C14	87-010-038-010		CAP, E 22-25V
C404	87-010-053-810		CAP, E 1-50V	C15	87-010-403-010		CAP, E 3.3-50V
C405	87-010-545-010		CAP, E 0.22-50V	C16	87-010-053-810		CAP, E 1-50V
C407	87-010-053-810		CAP, E 1-50V	C22	87-010-265-010		CAP, E 33-16V
C408	87-010-380-010		CAP, E 47-16V	C26	87-010-263-080		ELECT CAP 100-10V
C409	87-010-263-080		ELECT CAP 100-10V	C35	87-010-263-080		ELECT CAP 100-10V
C410	87-010-037-010		CAP, E 10-50V	C38	87-010-404-010		CAP, E 4.7-50V
C413	87-010-037-010		CAP, E 10-50V	C44	87-010-248-080		ELECT CAP 220-10V
C980	87-010-380-010		CAP, E 47-16V	C48	87-010-380-010		CAP, E 47-16V
D4	87-002-285-010		LED, 5-5 (RED)	C50	87-010-380-010		CAP, E 47-16V
D5	87-017-508-080		LED, 3MM (GRN)	C70	87-010-045-010		CAP, E 100-25V
D6	87-017-508-080		LED, 3MM (GRN)	C85	87-010-053-810		CAP, E 1-50V
D7	87-017-508-080		LED, 3MM (GRN)	C124	87-010-263-080		ELECT CAP 100-10V
D8	87-017-508-080		LED, 3MM (GRN)	C126	87-010-221-010		CAP, E 470-10V
D9	87-002-285-010		LED, 5-5 (RED)	C132	87-010-545-010		CAP, E 0.22-50V
D10	87-002-285-010		LED, 5-5 (RED)	C361	87-010-035-010		CAP, E 2.2-50V
D11	87-002-285-010		LED, 5-5 (RED)	C363	87-010-221-010		CAP, E 470-10V
D21	87-017-719-010		LED GL3EG8 3MM (GRN)	C364	87-010-263-080		ELECT CAP 100-10V
D22	87-017-719-010		LED GL3EG8 3MM (GRN)	C377	87-010-035-010		CAP, E 2.2-50V
D23	87-017-719-010		LED GL3EG8 3MM (GRN)	FB1	S1-011-620-000		FERRITE BEAD INDUCTOR
D24	87-017-719-010		LED GL3EG8 3MM (GRN)	FB2	S1-011-620-000		FERRITE BEAD INDUCTOR
D25	87-017-719-010		LED GL3EG8 3MM (GRN)	L1	87-005-196-080		INDUCTOR, 10UH
D26	87-017-719-010		LED GL3EG8 3MM (GRN)	L302	87-005-495-080		INDUCTOR 680UH
D27	87-017-719-010		LED GL3EG8 3MM (GRN)	SFR1	S1-030-850-000		SFR, 10K
D28	87-017-719-010		LED GL3EG8 3MM (GRN)	SFR2	87-024-176-080		SFR, 100K
				SFR3	87-024-176-080		SFR, 100K
				SFR4	87-024-176-080		SFR, 100K

REF. NO	PART NO.	KANRI NO.	DESCRIPTION
X1	S0-016-930-000		CER, RESO

POWER C.B

	S2-838-070-000		AC SOCKET COVER BLK
△	S4-000-010-000		AC CONTACT TERMINAL
△	S7-900-000-000		FUSE HOLDER
C743	87-010-404-010		CAP, E 4.7-50V
△F701	87-035-490-010		FUSE, 5A/250V 5-20
△J701	87-A60-178-010		SOCKET, AC 250V 2.5A

DRIVE C.B

SW1	87-036-340-019		SW, LEAF LSA-1121
M1	87-045-358-019		MOT, RF-310TA 43
M2	87-045-356-019		MOT, RF-310TA 30

MOTOR CD C.B

SW1	87-036-110-019		SW, PUSH SPPB 62
SW2	87-036-110-019		SW, PUSH SPPB 62
M1	87-045-305-019		MOTOR, RF-500TB

TRANSISTOR ILLUSTRATION



- 2SA952
- 2SA1015
- 2SA1296
- 2SA1318
- 2SC1815
- 2SC1923
- 2SC2001
- 2SC2240

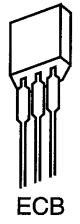

- 2SA933S
- 2SC1740S
- 2SD1468S
- DTA114TS
- DTA143ES
- DTA144TS
- DTC114TS
- DTC124XS
- DTC143ES
- DTC343TK

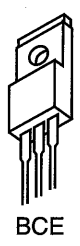

- 2SB1370

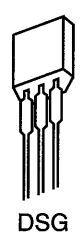

- 2SK161

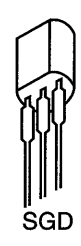

- 2SK246

LCD DISPLAY (AIW4035T-30P)

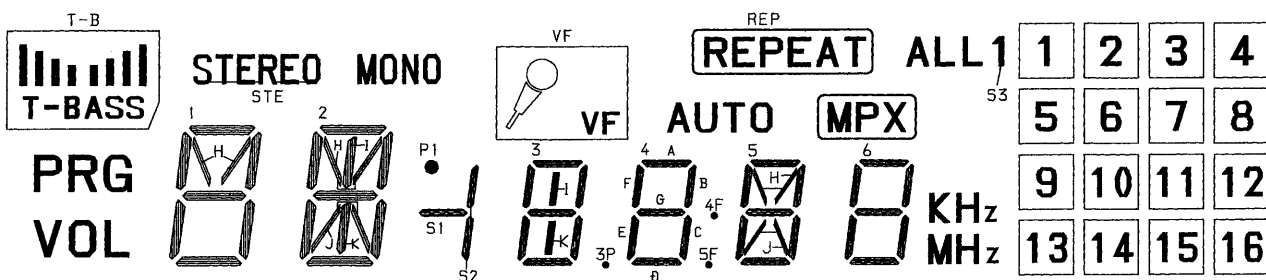
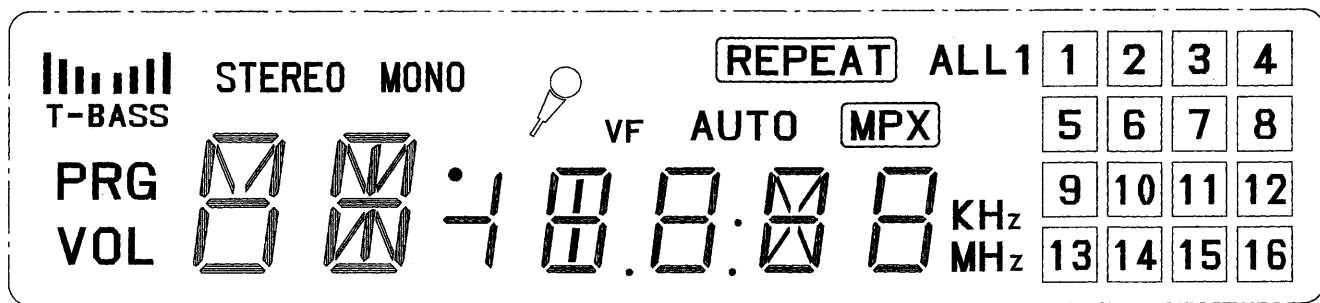

NO.	1	2	3	4	5	6	7	8	9	10	11	12	13	14	15	16	17
COM1	COM1	—	—	TOB	1A	1H	—	2I	2G	2K	2B	MONO	REP	3F	3A	3B	4F
COM2	—	COM2	—	PRG	1F	1G	1B	2A	2H	2J	2C	P1	VF	3G	3I	3C	4G
COM3	—	—	COM3	VOL	1B	1D	1C	STE	2F	2E	2D	S1	S2	3E	3D	3P	4E

18	19	20	21	22	23	24	25	26	27	28	29	30	31	32
4B	2A	AUTO	5A	5B	6F	6B	6A	5	6	7	8	4	MPX	ALL
4C	4P	5F	5HJ	5C	6G	6C	KHZ	9	10	11	12	3	—	—
4D	5P	5E	5G	5D	MHZ	13	MHZ	13	14	15	16	2	1	S3

BLOCK DIAGRAM-1 (MAIN)

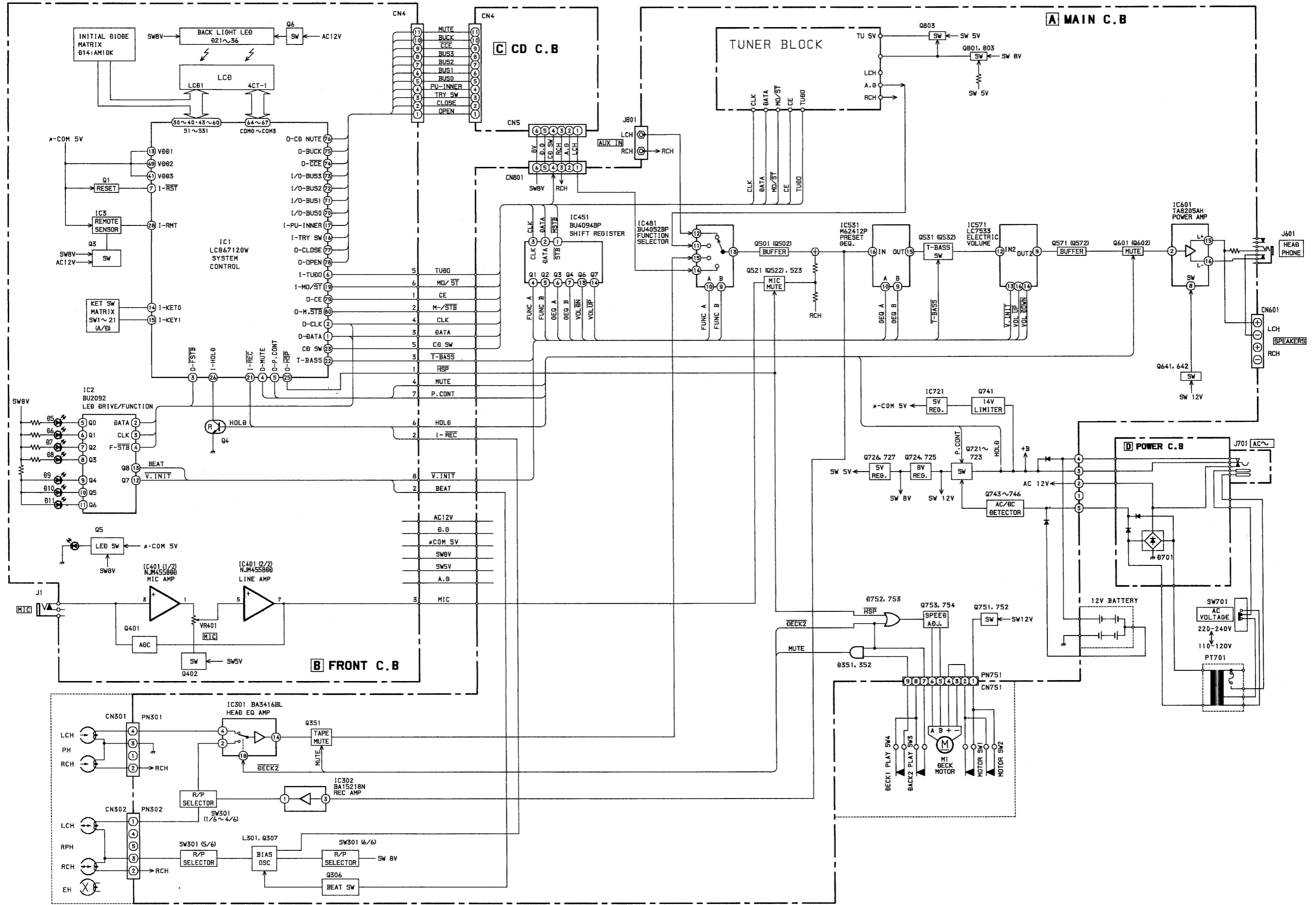

BLOCK DIAGRAM-2 (TUNER)

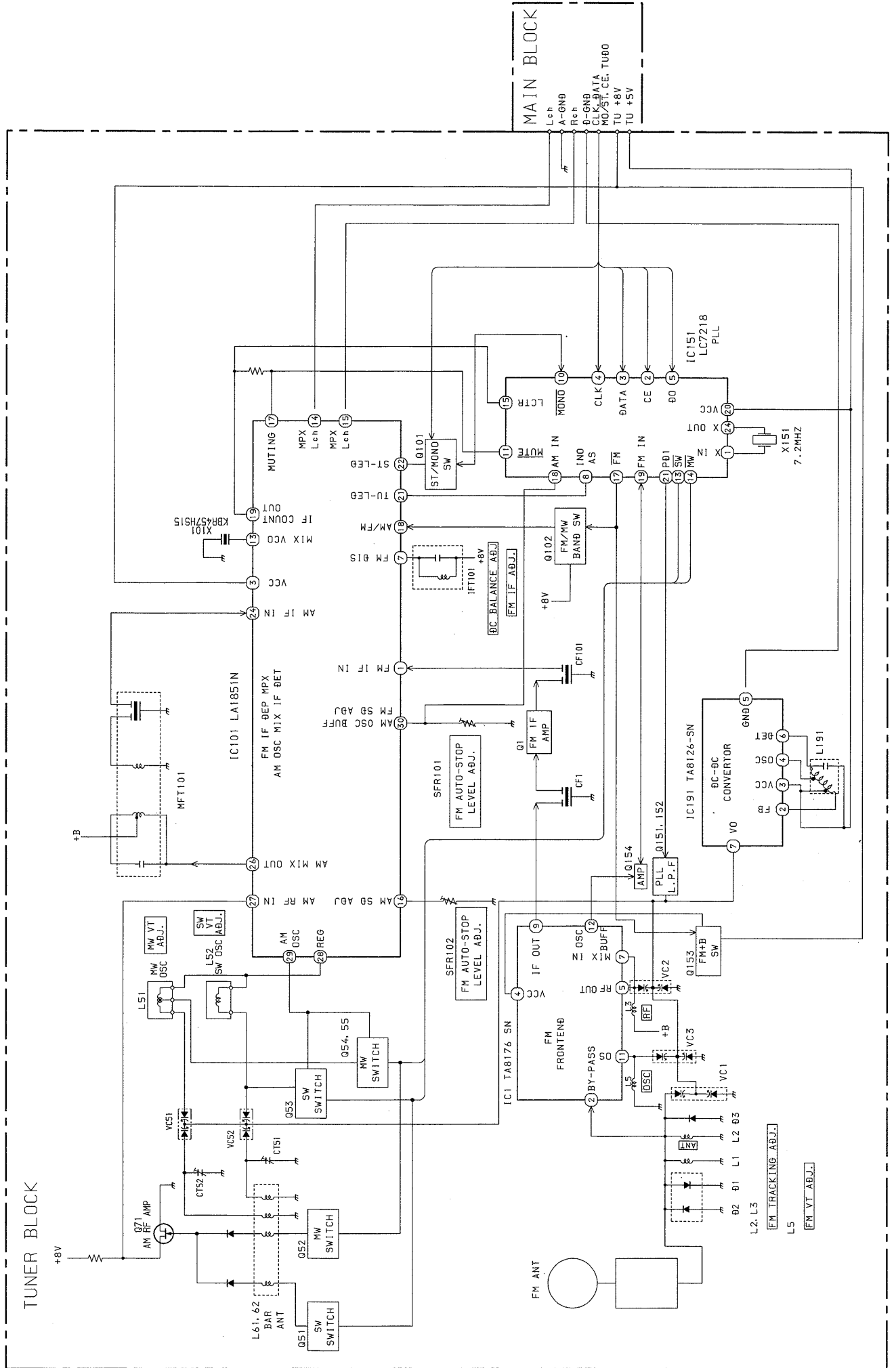

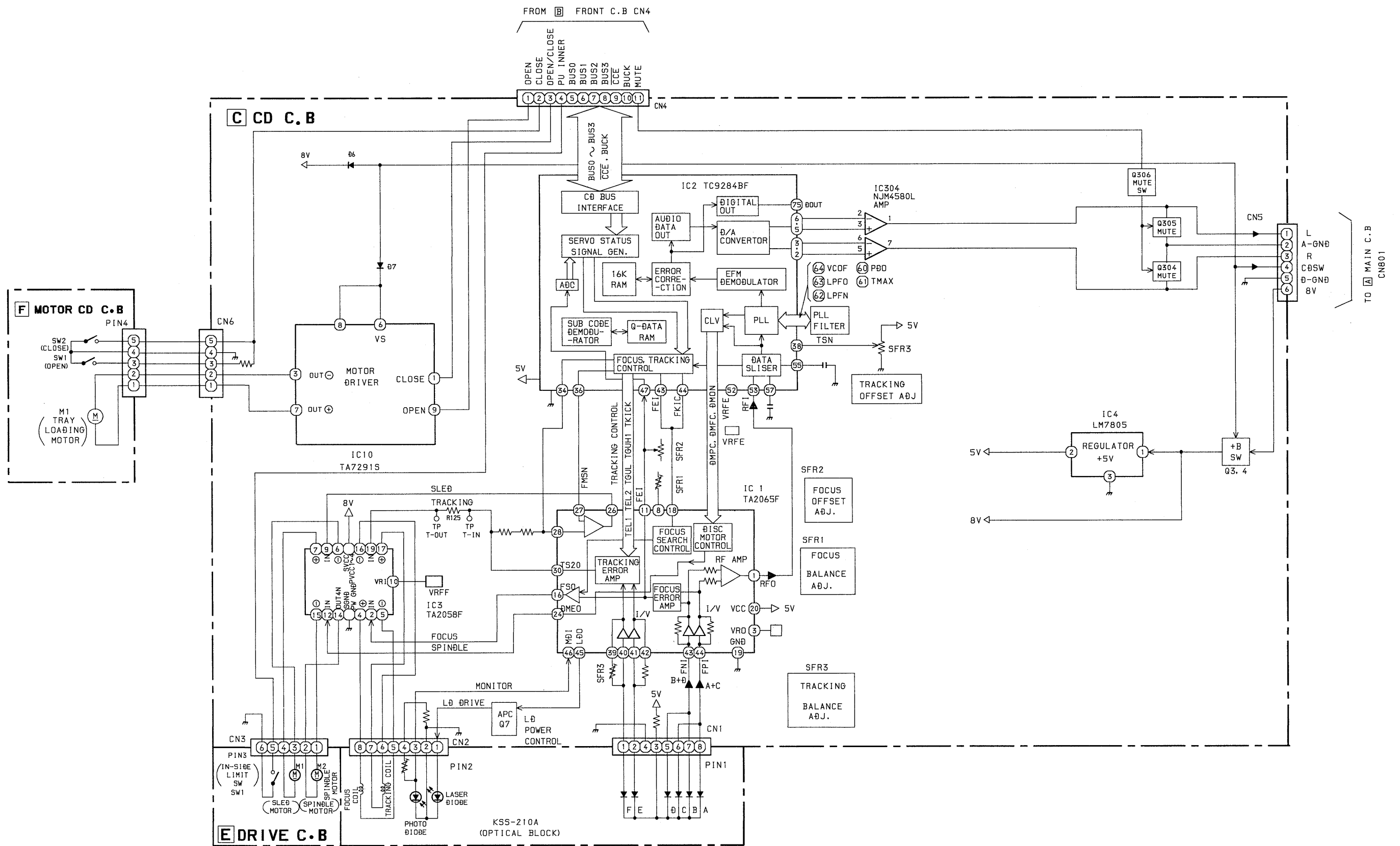

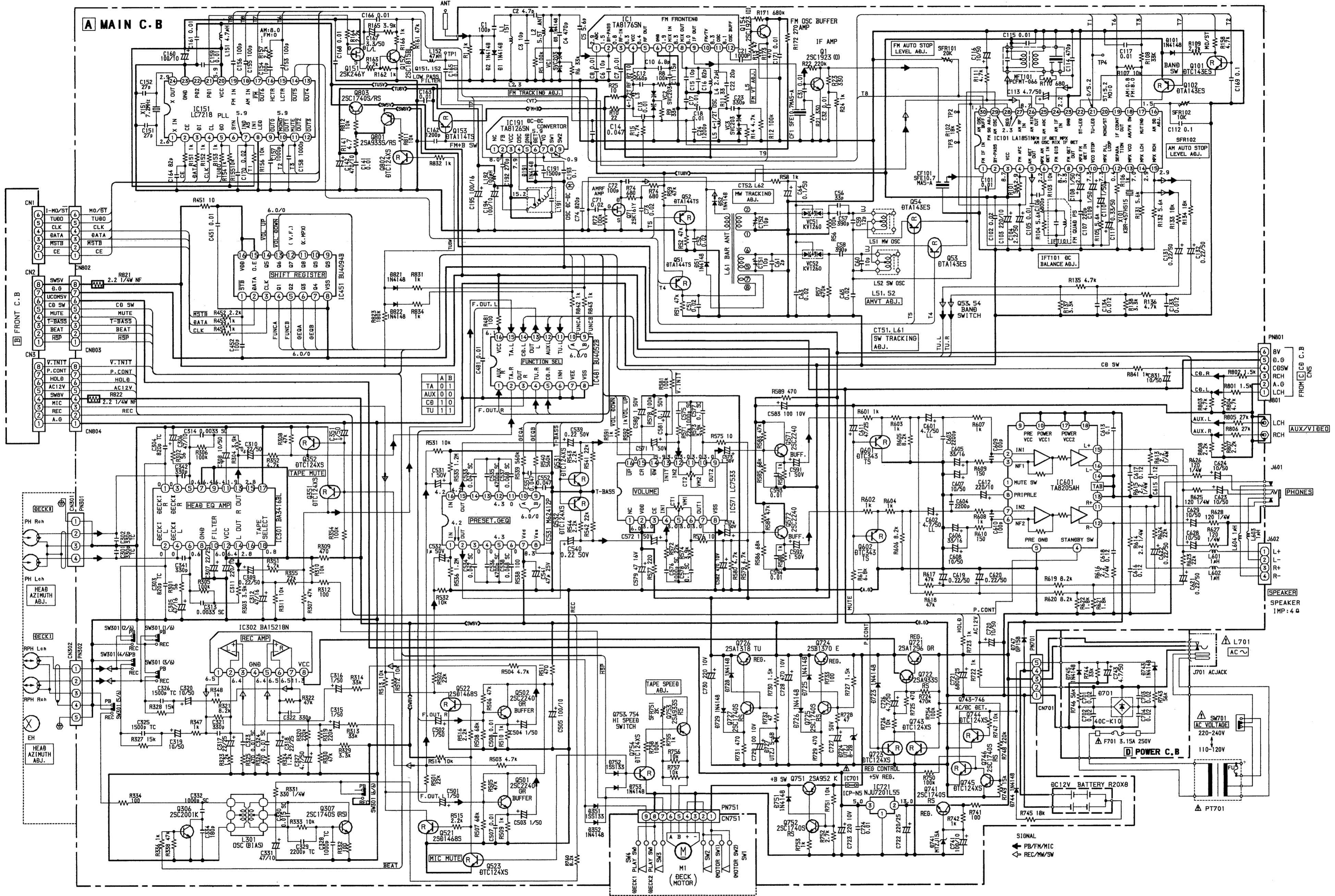

A
B
C
D
E
F
G
H
I
J

A MAIN C.B (PARTS SIDE)

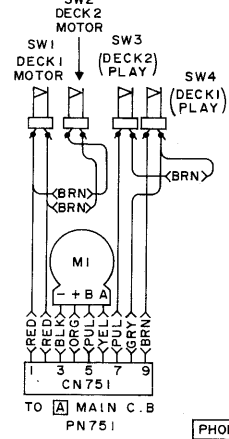
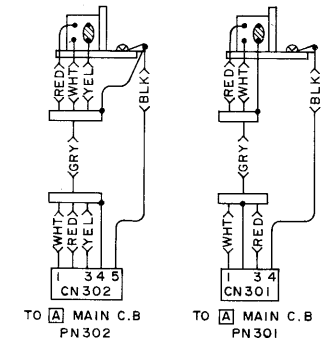

PHONES

D POWER C.B (PARTS SIDE)

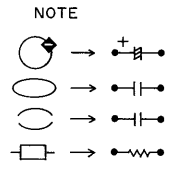
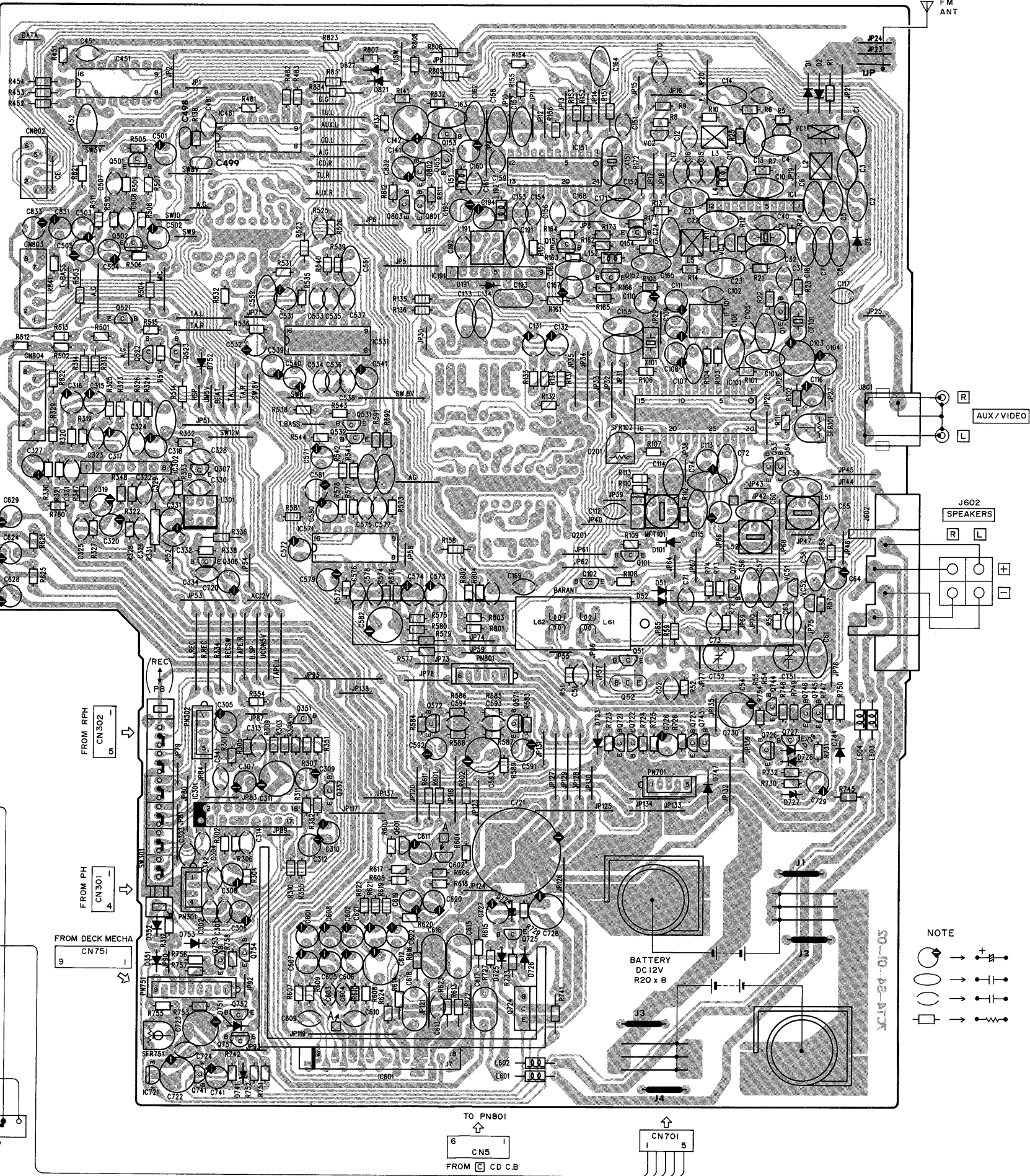
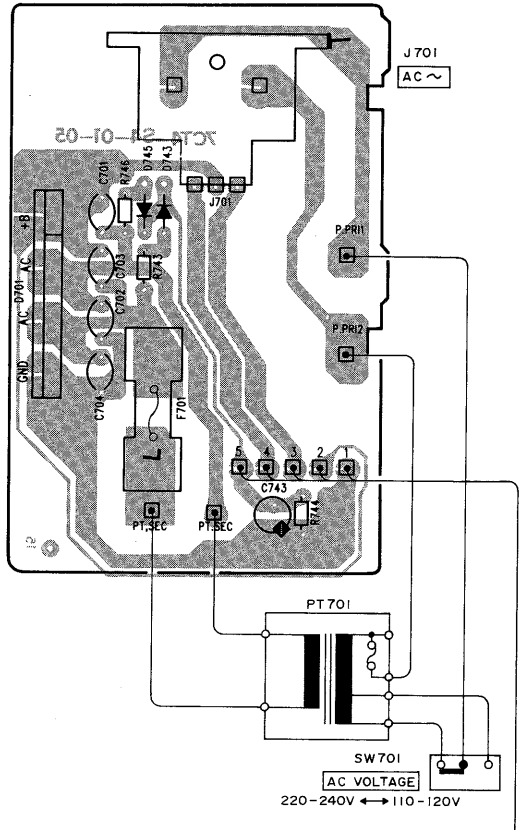

WIRING-2 (FRONT)

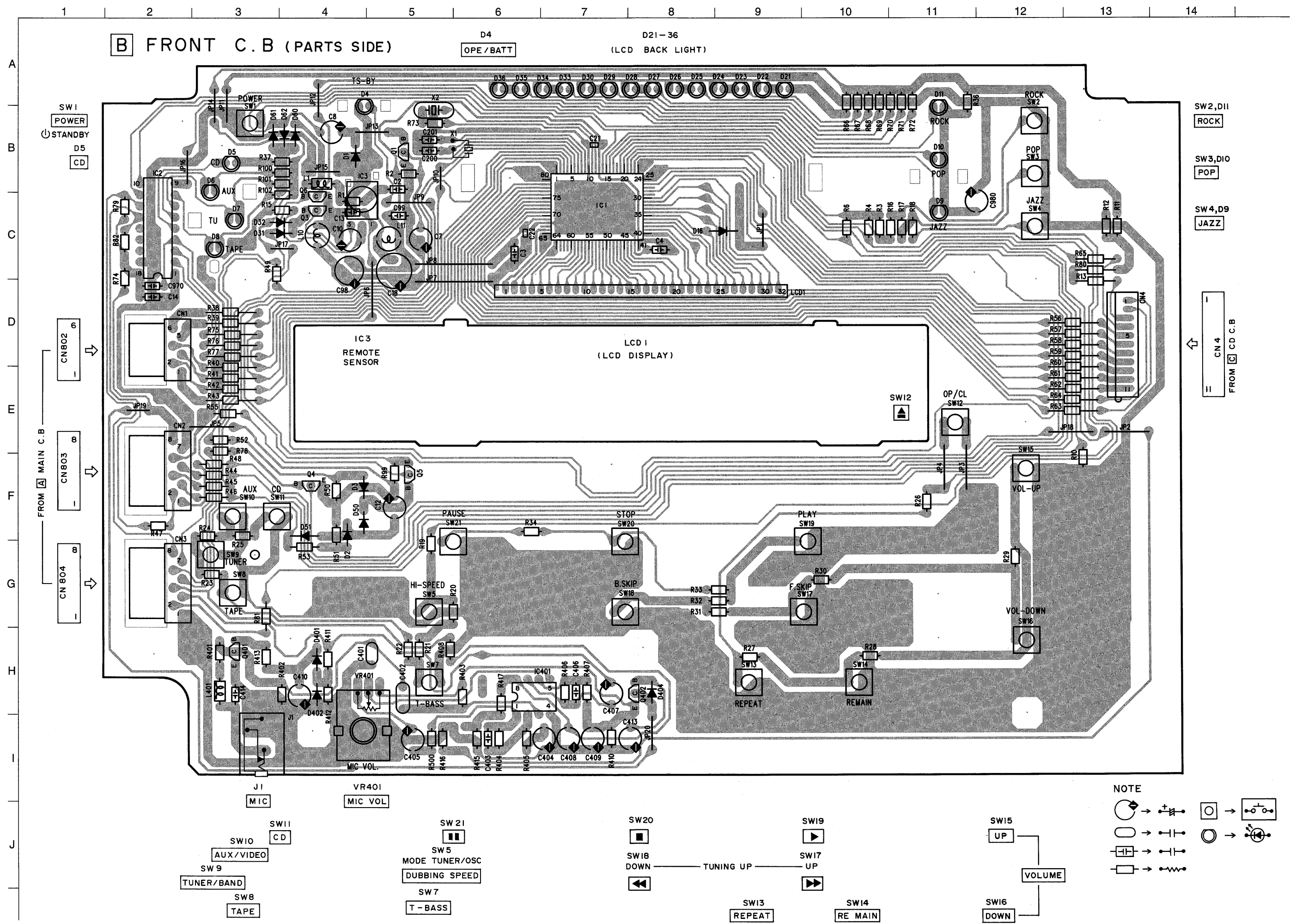

SCHEMATIC DIAGRAM-2 (FRONT)

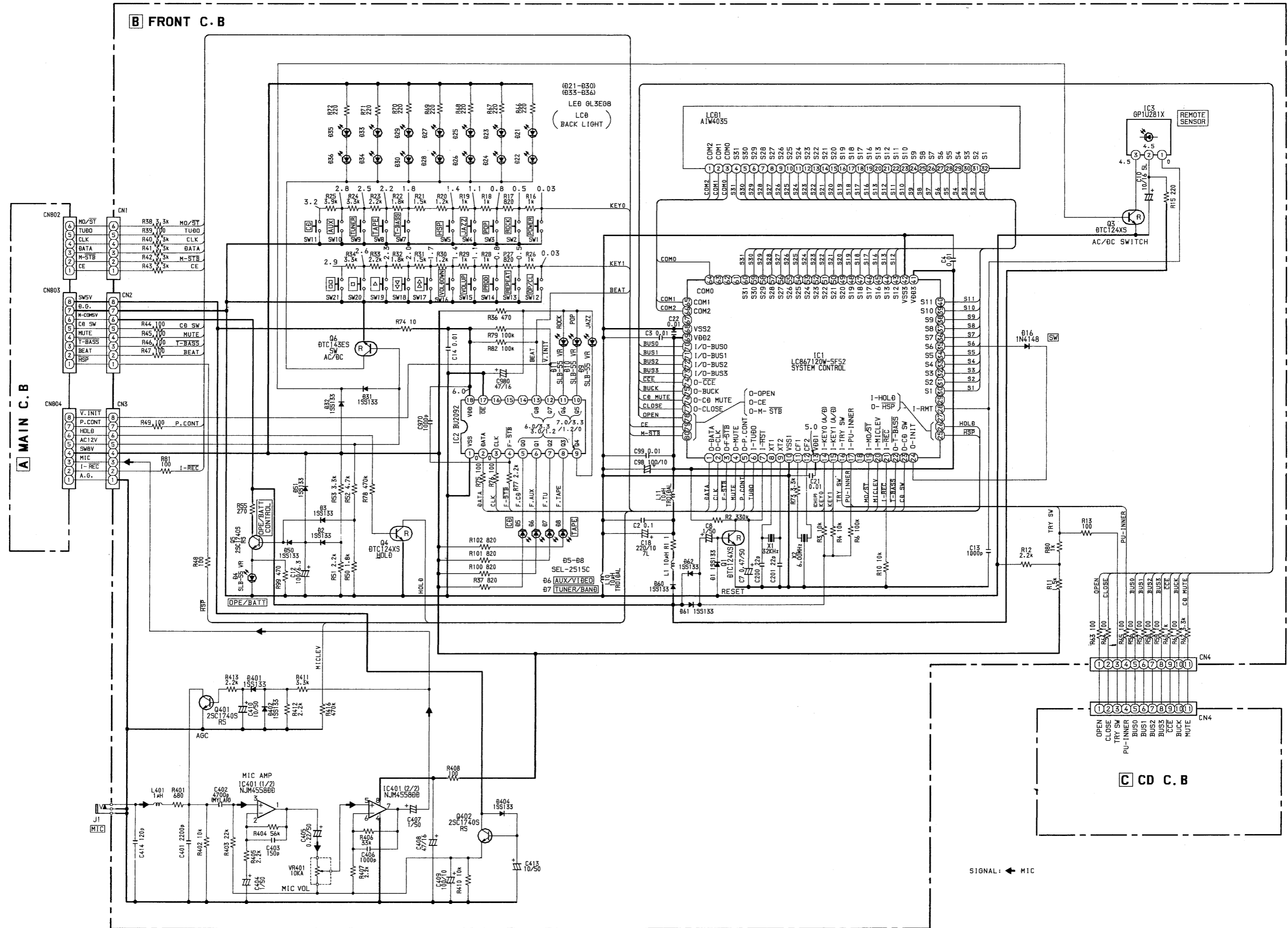

1 2 3 4 5 6 7 8 9 10 11 12 13 14

A B C D E F G H I J

FROM [A] MAIN C.B.
PN801
6 1

[C] CD C.B (PARTS SIDE)

FROM [B] FRONT C.B.
CN4

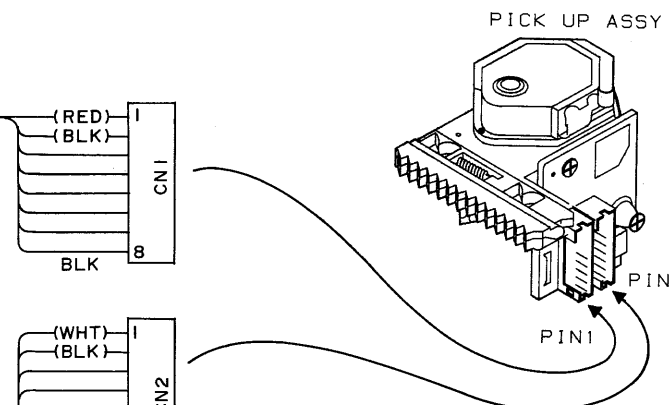
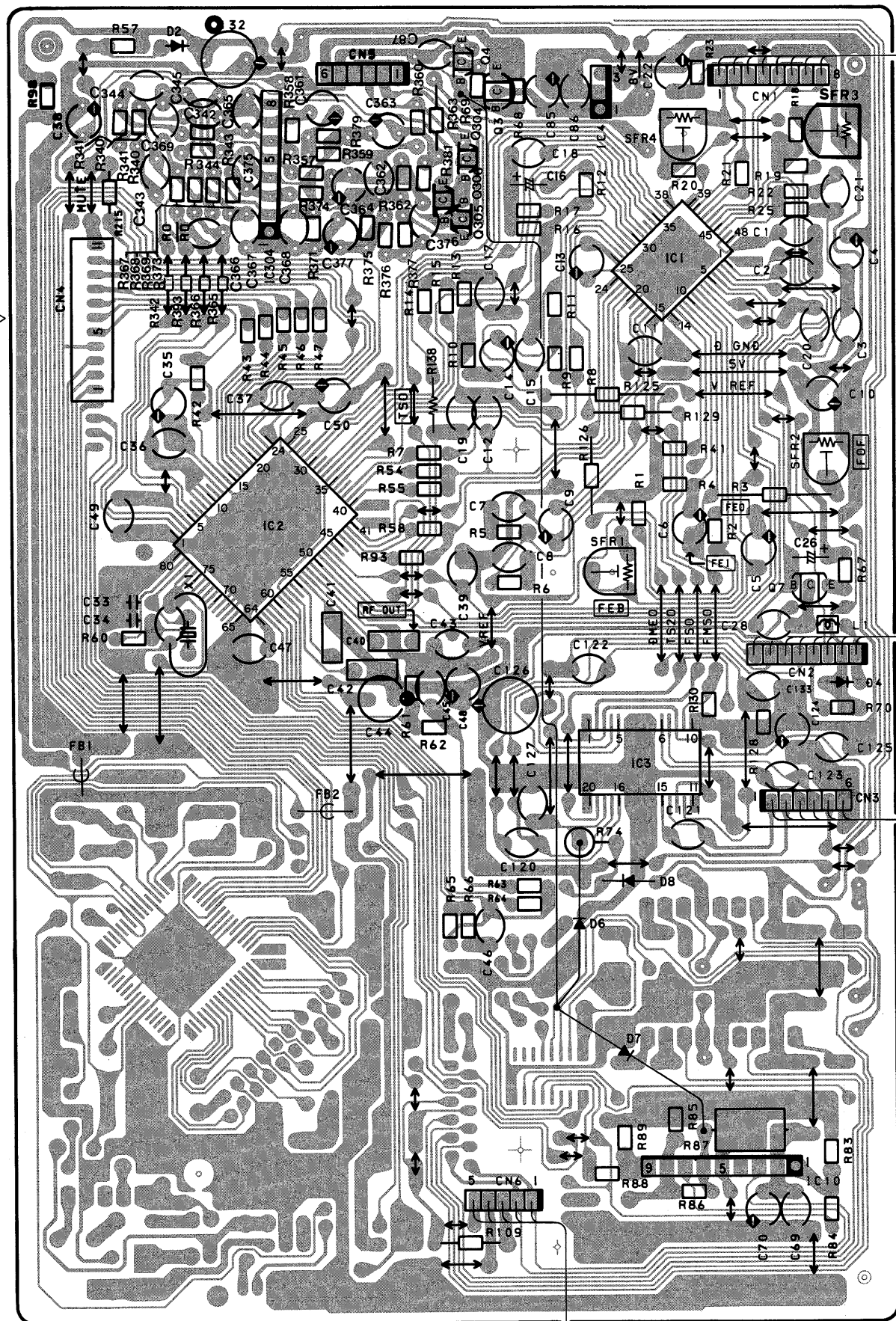

[F] DRIVE C.B (PATTERN SIDE)

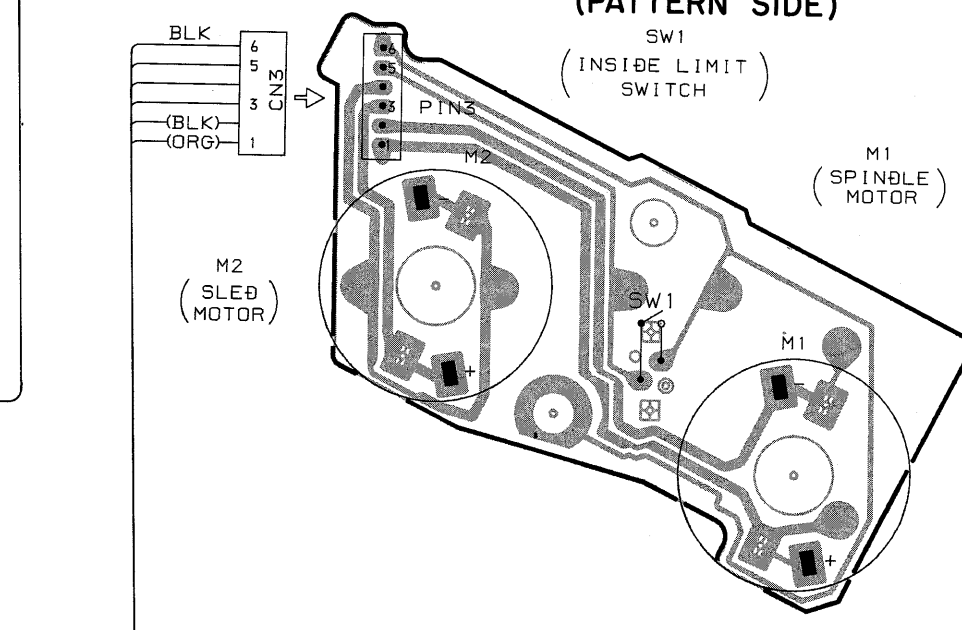

NOTE

- +
- -
- -
- -

SW1 (OPEN) SW2 (CLOSE) M1 (LOADING MOTOR)

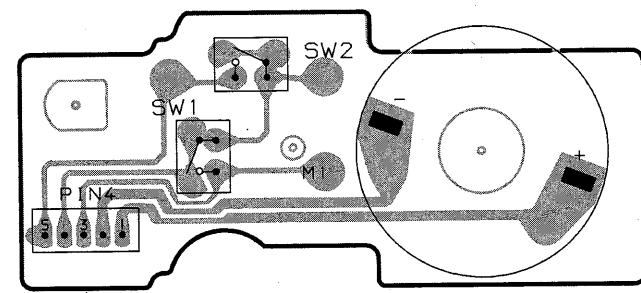

[G] MOTOR C.B (PATTERN SIDE)

SCHEMATIC DIAGRAM-3 (CD)

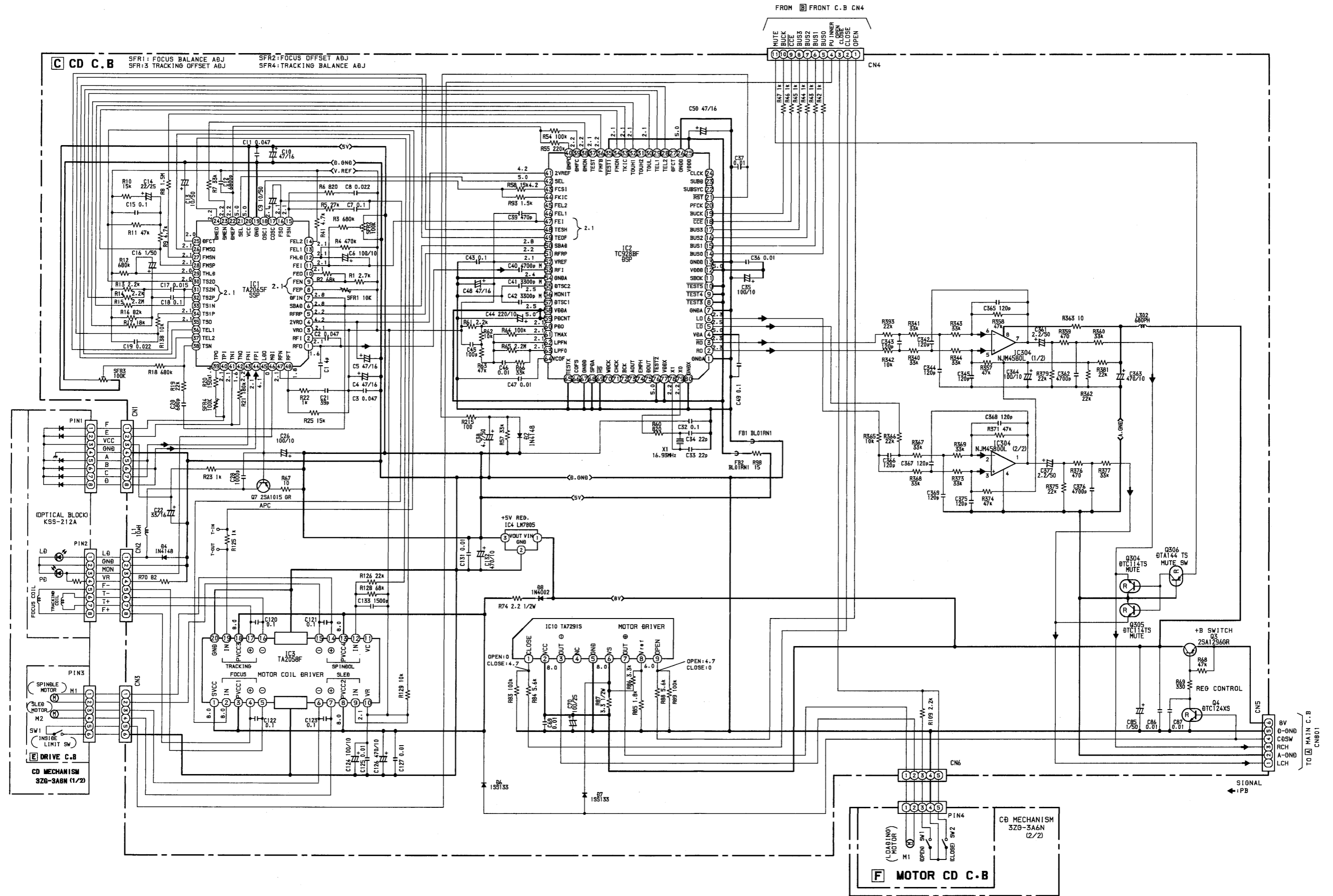

VOLTAGE CHART

TUNER SECTION

TEST CONDITION: SET TUNER AM/FM ON ONE FREQUENCY

IC151(LC7218)

PIN'S NUMBER	1	2	3	4	5	6	7	8	9	10	11	12
FM	2.56	0	0	0	5.30	0	5.70	0.00	/	5.68	0	2.50
AM	2.60	0	0	0	5.33	0	5.80	0	/	0	0	1.90
PIN'S NUMBER	13	14	15	16	17	18	19	20	21	22	23	24
FM	2.68	2.54	0	0	0.19	0.03	2.88	5.70	1.04	2.10	0	2.93
AM	0	1.95	0	0	8.03	2.91	0.02	5.81	1.19	1.70	0	2.98

IC1(TA8176SN)

PIN'S NUMBER	1	2	3	4	5	6	7	8	9	10	11	12
FM	2.91	1.49	0.77	7.57	7.70	0	1.90	7.57	7.29	0.02	7.53	7.38

IC101(LA1851N)

PIN'S NUMBER	1	2	3	4	5	6	7	8	9	10
FM	2.09	2.11	7.82	2.62	0	2.19	7.83	3.26	2.18	6.39
AM	2.34	2.34	0.04	2.41	0.70	2.18	8.04	2.31	2.18	6.63
PIN'S NUMBER	11	12	13	14	15	16	17	18	19	20
FM	6.38	0.38	6.11	3.05	3.14	1.51	0.05	7.82	0.07	0.80
AM	6.61	0.38	6.04	3.07	3.15	1.48	0.05	0.79	0.07	0.77
PIN'S NUMBER	21	22	23	24	25	26	27	28	29	30
FM	5.70	5.02	0	2.11	0.08	7.82	2.30	2.30	2.30	1.07
AM	5.81	0	0	2.34	0.69	8.04	2.26	2.26	2.26	0.79
	Q801(A933S)			Q802(C124)			Q803(C1740S)			
PIN'S NUMBER	E	C	B	E	C	B	E	C	B	
FM	8.31	8.08	7.53	0	0.02	1.50	5.72	5.84	6.44	
AM	8.32	8.20	7.57	0	0.02	1.50	5.82	5.86	6.50	

CASSETTE SECTION

TEST CONDITION: TAPE PLAY

IC301(BA3416BL)

PIN'S NUMBER	1	2	3	4	5	6	7	8	9
PLAY	0	0	0	0	0.59	0.59	5.68	0	5.68
PIN'S NUMBER	10	11	12	13	14	15	16	17	18
PLAY	5.31	0.66	5.68	2.62	2.59	0	0	0	0.34

IC302(BA15218N)

PIN'S NUMBER	1	2	3	4	5	6	7	8				
REC	5.97	5.97	5.84	0	5.84	5.97	5.97	9.17				
PIN'S NUMBER	Q306(C2001)			Q307(C1740S)			Q501(C2240)			Q502(C2240)		
	E	C	B	E	C	B	E	C	B	E	C	B
REC	0	9.90	0	0.90	5.28	0.11	2.53	5.83	3.15	2.54	5.83	3.17
	Q753(A933S)											
PIN'S NUMBER	E	C	B									
NOR SPEED	8.04	8.00	7.41									
HI SPEED	8.04	8.00	7.41									
	Q751(A952)			Q752(C1740S)								
PIN'S NUMBER	E	C	B	E	C	B						
TAPE	9.09	9.01	8.35	1.28	8.35	1.91						

POWER AMP SECTION

TEST CONDITION: TAPE PLAY

IC451(BU4094B)

PIN'S NUMBER	1	2	3	4	5	6	7	8
TAPE	0	0	0	0	5.84	0	0	0
RADIO	0	0	0	5.83	5.83	0	0	0
CD	0	0	0	5.86	0	0	0	0
AUX	0	0	0	0	0	0	0	0
PIN'S NUMBER	9	10	11	12	13	14	15	16
TAPE	5.84	5.84	5.84	5.84	5.84	5.84	5.84	5.84
RADIO	5.83	5.83	5.83	5.83	5.83	5.83	5.83	5.83
CD	5.86	5.86	5.86	5.86	5.86	5.86	5.86	5.86
AUX	5.86	5.86	5.86	5.86	5.86	5.86	5.86	5.86

IC481(BU4052BC)

PIN'S NUMBER	1	2	3	4	5	6	7	8
TAPE	0	0	0	0	0	0	0	0
RADIO	0	0	0	0	0	0	0	0
CD	0	0	0	0	0	0	0	0
AUX	0	0	0	0	0	0	0	0
PIN'S NUMBER	9	10	11	12	13	14	15	16
TAPE	5.87	0	0	0	0	0	0	5.87
RADIO	5.84	5.84	0	0	0	0	0	5.84
CD	0	5.87	0	0	0	0	0	5.87
AUX	0	0	0	0	0	0	0	5.87

IC571(LC7533)

PIN'S NUMBER	1	2	3	4	5	6	7	8
	5.83	5.83	5.83	2.90	2.91	2.91	2.91	0
PIN'S NUMBER	9	10	11	12	13	14	15	16
	2.91	2.91	2.91	2.90	5.76	5.87	0	5.87

IC531(M62417P)

PIN'S NUMBER	1	2	3	4	5	6	7	8
	4.27	4.22	0.41	0	4.29	0	7.68	0
PIN'S NUMBER	9	10	11	12	13	14	15	16
	0.04	0.05	0	4.30	0	0	4.24	4.27

IC601(TA8205AH)

PIN'S NUMBER	1	2	3	4	5	6	7	8	9			
	1.76	3.05	3.07	4.48	0	3.04	3.07	3.05	9.73			
PIN'S NUMBER	10	11	12	13	14	15	16	17				
	9.70	4.10	4.10	0	0	4.12	4.09	9.73				
	Q721(A1296)			Q722(A933S)			Q726(A1318)			Q727(C1740S)		
PIN'S NUMBER	E	C	B	E	C	B	E	C	B	E	C	B
	9.84	9.14	9.15	9.15	9.15	8.48	8.35	5.88	7.67	5.16	7.67	5.71

CD SECTION
TEST CONDITION:CD PLAY
IC1(TA2065F)

PIN'S NUMBER	1	2	3	4	5	6	7	8	9	10	11	12
	0.90	1.00	2.20	4.40	1.80	2.20	2.20	2.20	2.20	2.20	2.20	1.90
PIN'S NUMBER	13	14	15	16	17	18	19	20	21	22	23	24
	2.00	2.20	2.20	2.00	2.00	2.60	0.00	4.50	0.00	1.80	2.20	2.20
PIN'S NUMBER	25	26	27	28	29	30	31	32	33	34	35	36
	1.80	2.20	2.20	2.20	0.60	2.20	2.20	1.70	2.20	2.20	2.20	2.20
PIN'S NUMBER	37	38	39	40	41	42	43	44	45	46	47	48
	2.20	2.20	2.20	2.20	2.20	2.20	2.20	2.20	4.40	0	2.20	1.20

IC2(TC9284F)

PIN'S NUMBER	1	2	3	4	5	6	7	8	9	10	11	12	13	14
	2.80	3.00	2.40	4.40	2.40	3.00	2.80	4.40	4.40	4.40	0	4.40	0	4.60
PIN'S NUMBER	15	16	17	18	19	20	21	22	23	24	25	26	27	28
	4.60	4.60	4.60	4.60	4.60	2.20	4.40	0	0	0	4.50	0	0	2.20
PIN'S NUMBER	29	30	31	32	33	34	35	36	37	38	39	40	41	42
	2.00	2.20	0	2.20	0	2.20	4.60	0.40	3.80	2.00	2.20	0.80	4.40	0
PIN'S NUMBER	43	44	45	46	47	48	49	50	51	52	53	54	55	56
	2.20	2.40	0	0	2.00	2.20	2.20	1.70	1.60	2.20	1.50	0	1.60	2.20
PIN'S NUMBER	57	58	59	60	61	62	63	64	65	66	67	68	69	70
	2.00	4.40	4.40	2.20	0	1.20	3.80	0	0	4.40	0	0	0	2.20
PIN'S NUMBER	71	72	73	74	75	76	77	78	79	80				
	2.20	2.20	0	4.40	2.20	4.40	0	0	0	0				

IC3(TA2058F)

PIN'S NUMBER	1	2	3	4	5	6	7	8	9	10
	8.00	2.00	8.00	3.80	3.80	3.80	3.80	8.00	2.20	2.20
PIN'S NUMBER	11	12	13	14	15	16	17	18	19	20
	3.6	2.00	8.00	3.80	3.80	3.80	3.80	8.00	2.20	0

IC10(TA7291S)

PIN'S NUMBER	1	2	3	4	5	6	7	8	9
	0	8.00	0	0	0	8.00	0	3.00	0

IC1(LC867116W)

PIN'S NUMBER	1	2	3	4	5	6	7	8	9	10	11	12	13	14
	0	0	0	0	4.40	3.40	1.80	0	0	0	4.40	4.40	4.40	4.40
PIN'S NUMBER	15	16	17	18	19	20	21	22	23	24	25	26	27	28
	4.40	0	0	0	0	2.40	0	0	0	4.50	4.50	0	0	4.20
PIN'S NUMBER	29	30	31	32	33	34	35	36	37	38	39	40	41	42
	1.80	1.80	1.80	1.80	1.80	1.80	1.80	1.80	1.80	1.80	1.80	1.80	4.50	0
PIN'S NUMBER	43	44	45	46	47	48	50	51	52	53	54	55	56	57
	1.80	1.80	2.00	2.00	2.00	1.80	1.80	1.80	1.90	1.90	1.90	1.90	1.80	2.00
PIN'S NUMBER	58	59	60	61	62	63	64	65	66	67	68	69	70	71
	2.00	1.90	1.90	0	0	0	1.90	1.90	1.90	0	0	4.40	0	0
PIN'S NUMBER	72	73	74	75	76	77	78	79	80					
	0	0	0	0	0	0	0	0	0					

IC DESCRIPTION
IC, LC867116W-5844

Pin No.	Pin Name	I/O	Description
1	O-DATA	O	PLL, shift register data output.
2	O-CLK	O	PLL, shift register clock output.
3	$\overline{\text{O-FSTB}}$	O	Shift register data latch strobe output.
4	O-MUTE	O	Main mute output.
5	O-PCONT	O	Machine power supply control output.
6	I-TUDO	I	PLL IC tuner data input.
7	$\overline{\text{I-RST}}$	I	Microprocessor reset..
8	XT1	I	Connected to 32.768 kHz crystal.
9	XT2	O	Connected to 32.768 kHz crystal.
10	VSS1	—	GND.
11	CF1	I	Connected to 6 MHz ceramic lock.
12	CF2	O	Connected to 6 MHz ceramic lock.
13	VDD1	—	Microprocessor power supply (5 V).
14	I-KEY0	I	Key A/D input.
15	I-KEY1	I	Key A/D input.
16	I-TRY SW	I	CD tray open/close switch A/D input.
17	I-PU-INNER	I	CD inside limit switch input.
18	—	I	N.C.
19	I-MO/ $\overline{\text{ST}}$	I	Tuner · stereo detection.
20	I-MICLEV	I	Microphone level detection.
21	$\overline{\text{I-REC}}$	I	N.C.
22	$\overline{\text{O-T-BASS}}$	O	T-bass circuit ON/OFF switch output (ON: L).
23	O-CDSW	O	CD block power supply control output (ON: H).
24	O-INIT	O	Initial setting output.
25	$\overline{\text{O-HSP}}$	O	High speed dubbing selector output (ON: L).
26	I-HOLD	I	Hold backup mode at "H".
27	—	I	N.C.
28	I-RMT	I	Remote control input.
29	PAO	I	Initial setting input.
30	S1	O	LCD segment output.
31-40	S2-S11	O	LCD segment output and initial setting output at the same time.
41	VDD3	—	Microprocessor power supply.
42	VSS3	—	GND.
43	S12	O	LCD segment output.
44	S13	O	LCD segment output.
45-60	S16-31	O	LCD segment output.
61	V3	—	LCD drive bias power supply.
62	V2	—	LCD drive bias power supply.
63	V1	—	LCD drive bias power supply.
64	COM0	O	LCD common output.
65	COM1	O	LCD common output.

Pin No.	Pin Name	I/O	Description
66	COM2	O	LCD common output.
67	COM3	O	N.C.
68	VSS2	—	GND.
69	VDD2	—	CD IC control data bus input/output.
70	I/O BUS0	I/O	CD IC control data bus input/output.
71	I/O BUS1	I/O	CD IC control data bus input/output.
72	I/O BUS2	I/O	CD IC control data bus input/output.
73	I/O BUS3	I/O	CD IC control data bus input/output.
74	$\overline{\text{O-CCE}}$	O	CD IC control chip enable output.
75	O-BUCK	O	CD IC control data bus clock output.
76	O-CDMUTE	O	CD mute output.
77	O-CLOSE	O	CD tray close output (Close ON: H).
78	O-OPEN	O	CD tray open output (Close ON: H).
79	O-CE	O	PLL chip enable output.
80	O-MSTB	O	Shift register (MAIN C.B.) data latch strobe output.

IC, TA2065F

Pin No.	Pin Name	I/O	Description
1	RFO	O	RF amp (RF AMP) output terminal.
2	RFI	I	RF ripple signal generating circuit input terminal.
3	VRO	O	VR amp output terminal.
4	2VRO	O	2VR amp output terminal.
5	RFRP	O	RF ripple signal output terminal.
6	SBAD	O	Defects detection signal output terminal.
7	DFIN	I	Defect detecting comparator positive phase input terminal.
8	FEP	I	Focus error balance adjusting input terminal.
9	FEN	I	Focus error amp (FE AMP) negative phase input terminal.
10	FEO	O	Focus error amp (FE AMP) output terminal.
11	FEI	I	Focus output amp (FS AMP) positive phase input terminal.
12	FHLD	I	Hold switch terminal for defect.
13	FEL1	I	Focus gain adjusting terminal.
14	FEL2	I	Focus gain adjusting terminal.
15	FSN	I	Focus output amp (FS AMP) negative phase input terminal.
16	FSO	O	Focus output amp (FS AMP) output terminal.
17	COSC	O	Focus search signal generating capacitor connecting terminal.
18	OSCI	I	Focus search signal generating built-in current source control input terminal.
19	GND	—	Ground terminal.
20	VCC	—	Power source terminal.
21	SEL	I	Analog switch control signal input terminal.
22	DMEP	I	Disc motor amp (DM AMP) positive phase input terminal.
23	DMEN	I	Disc motor amp (DM AMP) negative phase input terminal.
24	DMEO	O	Disc motor amp (DM AMP) output terminal.
25	DFCT	I	Defect detecting comparator negative phase input terminal.
26	FMSO	O	Feed motor output amp (FMS AMP) output terminal.
27	FMSN	I	Feed motor output amp (FMS AMP) negative phase input terminal.
28	FMSP	I	Feed motor output amp (FMS AMP) positive phase input terminal.
29	THLD	I	Hold switch terminal for defect.
30	TS2O	O	Tracking servo amp 2 (TS2 AMP) output terminal.
31	TS2N	I	Tracking servo amp 2 (TS2 AMP) negative phase input terminal.
32	TS2P	I	Tracking servo amp 2 (TS2 AMP) positive phase input terminal.
33	TS1N	I	Tracking servo amp 1 (TS1 AMP) negative phase input terminal.
34	TS1P	I	Tracking servo amp 1 (TS1 AMP) positive phase input terminal.
35	TSO	O	Tracking output amp (TS AMP) output terminal.
36	TEL1	I	Tracking gain adjusting terminal.
37	TEL2	I	Tracking gain adjusting terminal.
38	TSN	I	Tracking output amp (TS AMP) negative phase input terminal.
39	TPO	O	Sub-beam I-V amp output terminal.
40	TPI	I	Sub-beam I-V amp input terminal.
41	TNI	I	Sub-beam I-V amp input terminal.

Pin No.	Pin Name	I/O	Description
42	TNO	O	Sub-beam I-V amp output terminal.
43	FNI	I	Main-beam I-V amp input terminal.
44	FPI	I	Main-beam I-V amp input terminal.
45	LDO	O	Laser diode amp output terminal.
46	MDI	I	Monitor photo diode amp input terminal.
47	RFN	I	RF amp negative phase input terminal.
48	RFT	I	RF amp peaking terminal.

IC, TC9284AF

Pin No.	Pin Name	I/O	Description
1	GNDA	—	D/A converter R-channel analog GND.
2	RO	O	R-channel data positive output.
3	\overline{RO}	O	R-channel data inverted output.
4	VDA	—	D/A converter power supply.
5	\overline{LO}	O	L-channel data inverted output.
6	LO	O	L-channel data positive output.
7	GNDA	—	D/A converter L-channel analog GND.
8-10	$\overline{TEST3-TEST5}$	I	TEST pin. Normally “H” or open.
11	SBOK	O	Sub code Q data CRCC judgment result output. Judgment result OK: H
12	VDDD	—	Digital power supply. (+5 V)
13	GNDD	—	Digital GND.
14-17	BUS0-BUS3	I/O	μ processor interface, data input/output.
18	CCE	I	μ processor interface, chip enable signal input. When “L”: BUS 3-0 are active
19	BUCK	I	μ processor interface, clock input.
20	PFCK	O	PB frame sync output.
21	\overline{RST}	I	Reset signal input. “L” at reset.
22	SUBSYC	O	Sub code block sync output. When sub code is detected, “H” at S1 position.
23	SUBD	O	Sub code P-W output.
24	CLCK	I	Sub code P-W data read clock input.
25	VDDD	—	Digital power supply. (+5 V)
26	GNDD	—	Digital GND.
27	DFCT	O	Defect detection signal output. When defect is detected: “VREF”, normally “HiZ”.
28	TEL2	O	Tracking gain adjustment analog switch output. “VREF”, or “HiZ”.
29	TEL1	O	Tracking gain adjustment analog switch output. “VREF”, or “HiZ”.
30	TGUL	O	Analog switch output for tracking servo gain up. Polarity in gain-up mode and normal mode can be selected by command.
31	TGUH2	O	Analog switch output for tracking servo gain up. “HiZ” for gain-up, normally “VREF”.
32	TUGH1	O	TGUH1 during normal playback. TGUH2: not used
33	TKIC	O	Tracking actuator kick signal output. NKICx and CKICx are used for kick during tracking gain adjustment. “VREF” for outermost track. “O” for moving toward inner track. Normally “HiZ”.
34	FMON	O	Analog switch output to turn ON/OFF the feed servo. “HiZ” to turn ON servo. “VREF” to turn OFF servo.
35	$\overline{TEST1}$	I	TEST pin. Normally “H” or open.
36	FMFB	O	Feed motor FWD/BWD direction control signal output. “2VREF” for outmost track. “O” for moving toward inner track. Normally “HiZ”.
37	\overline{TEST}	I	TEST pin. Normally “H” or open.
38	DMON	O	Analog switch output to select gain of the disc motor drive circuit. “HiZ” for CLV servo OFF, “HiZ” or “VREF” can be selected by command.

Pin No.	Pin Name	I/O	Description																
39	DMPC	O	Disc motor CLV servo AFC signal output.																
			<table border="1"> <thead> <tr> <th>Operation</th> <th>Command</th> <th>DMFC output</th> </tr> </thead> <tbody> <tr> <td>Motor acceleration</td> <td>DMFK</td> <td>"2VREF"</td> </tr> <tr> <td>CLV servo ON</td> <td>DMSV</td> <td>AFC signal (PWM)</td> </tr> <tr> <td>Motor brake</td> <td>DMBK</td> <td>"L"</td> </tr> <tr> <td>CLV servo OFF</td> <td>DMOFF</td> <td>"VREF"</td> </tr> </tbody> </table>	Operation	Command	DMFC output	Motor acceleration	DMFK	"2VREF"	CLV servo ON	DMSV	AFC signal (PWM)	Motor brake	DMBK	"L"	CLV servo OFF	DMOFF	"VREF"	
			Operation	Command	DMFC output														
			Motor acceleration	DMFK	"2VREF"														
			CLV servo ON	DMSV	AFC signal (PWM)														
Motor brake	DMBK	"L"																	
CLV servo OFF	DMOFF	"VREF"																	
40	DMPC	O	Disc motor CLV servo APC signal output.																
41	2VREF	—	Analog power supply. (twice the "VREF" voltage)																
42	SEL	O	Servo mode select output. It turns ON/OFF the laser diode (LD) and focus servo.																
			<table border="1"> <thead> <tr> <th>SEL output</th> <th>LD</th> <th>Focus servo</th> <th>Operating mode</th> </tr> </thead> <tbody> <tr> <td>"L"</td> <td>OFF</td> <td>OFF</td> <td>LD OFF</td> </tr> <tr> <td>"HiZ"</td> <td>ON</td> <td>OFF</td> <td>Focus search</td> </tr> <tr> <td>"H"</td> <td>ON</td> <td>ON</td> <td>Focus ON (normal play)</td> </tr> </tbody> </table>	SEL output	LD	Focus servo	Operating mode	"L"	OFF	OFF	LD OFF	"HiZ"	ON	OFF	Focus search	"H"	ON	ON	Focus ON (normal play)
			SEL output	LD	Focus servo	Operating mode													
			"L"	OFF	OFF	LD OFF													
"HiZ"	ON	OFF	Focus search																
"H"	ON	ON	Focus ON (normal play)																
43	FCSI	O	Focus actuator drive signal output during focus search mode. "VDDA" to move the lens far from disc. "L" to move the lens closer to disc. Normally "HiZ".																
44	FKIC	O	Focus actuator drive signal output during focus adjustment mode. "VDDA" to move the lens far from disc. "L" to move the lens closer to disc. Normally "HiZ".																
45, 46	FEL1, FEL2	O	Focus gain adjustment analog switch output. "VREF" or "HiZ".																
47	FEI	I	Focus error signal input.																
48	TESH	I	Analog switch input to track error signal sample-and-hold.																
49	TEOF	O	Focus gain adjustment analog switch output. "VREF" when tracking servo off.																
50	SBAD	I	Sub beam added signal input.																
51	RFRP	I	RF ripple signal input.																
52	VREF	—	Analog power supply.																
53	RFI	I	RF signal input.																
54	GND A	—	Analog GND.																
55	DTSC2	O	Data slice control EFM signal inverted output.																
56	MONI T	O	Internal signal monitored output. EFMO, PLCK or LOCK signals can be selected by command. Can be muted. (Not used)																
57	DTSC 1	O	Data slice control EFM signal positive polarity output.																
58	VDDA	—	Analog power supply.																
59	PDCNT	I	PDO output control signal input. "L" to fix to "HiZ" forcibly. "H" : normal output.																
60	PDO	O	Phase error signal between EFM and PLCK signals is output.																
61	TMAX	O	TMAX detected result output.																
			<table border="1"> <thead> <tr> <th>TMAX detected result</th> <th>TMAX output</th> </tr> </thead> <tbody> <tr> <td>Longer than specified cycle</td> <td>"L"</td> </tr> <tr> <td>Shorter than specified cycle</td> <td>"VREF"</td> </tr> <tr> <td>Within specified cycle</td> <td>"HiZ"</td> </tr> </tbody> </table>	TMAX detected result	TMAX output	Longer than specified cycle	"L"	Shorter than specified cycle	"VREF"	Within specified cycle	"HiZ"								
			TMAX detected result	TMAX output															
			Longer than specified cycle	"L"															
Shorter than specified cycle	"VREF"																		
Within specified cycle	"HiZ"																		
62	LPFN	I	Low-pass filter amplifier inverted input.																

Pin No.	Pin Name	I/O	Description
63	LPFO	O	Low-pass filter amplifier output.
64	VCOF	O	VCO filter output.
65	TESTX	I	TEST pin. Normally "H" or "L" .(Connected to +5 V)
66	$\overline{\text{HS}}$	O	Double speed mode output. "H" : normal speed. "L" : double speed
67	GNDD	—	Digital GND.
68	SPDA	O	Processor status signal output.
69	COFS	O	Correction circuit frame clock (7.35 kHz) output.
70	WDCK	O	Word clock (88.2 kHz) output. SUBQ, BUF0V or 1PF can be selected by the μ processor command. (Not used)
71	CHCK	O	Channel clock (44.1 kHz) output. "L"for L-channel. "H" for R-channel.
72	BCK	O	Bit clock (1.4112 MHz) output.
73	AOUT	O	Audio data output. (Not used)
74	EMPH	O	Emphasis ON/OFF select signal. "H" : emphasis ON. "L" for emphasis OFF
75	DOUT	O	DIGITAL SIGNAL output.
76	$\overline{\text{TEST2}}$	I	TEST pin. Normally "H".
77	VDDX	—	Crystal oscillator circuit power supply.
78	XI	I	External crystal oscillator is connected. (Crystal oscillator frequency 16.9344 MHz)
79	XO	O	External crystal oscillator is connected. (Crystal oscillator frequency 16.9344 MHz)
80	GNDX	—	Crystal oscillator GND.

IC BLOCK DIAGRAM

IC, BA3416BL

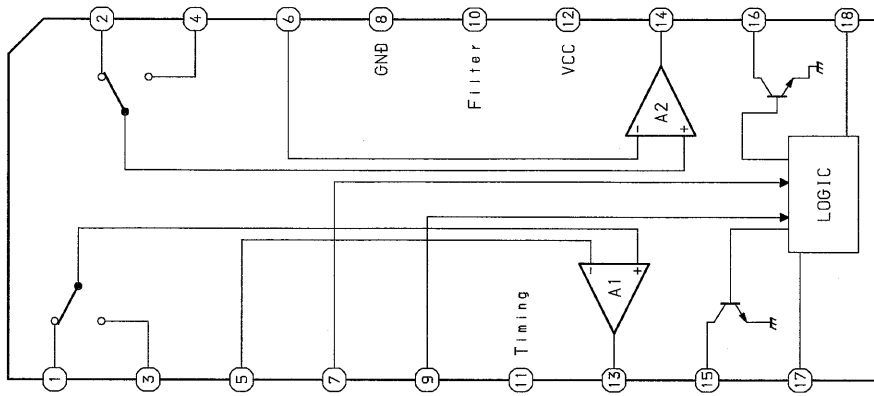

IC, BU2092F

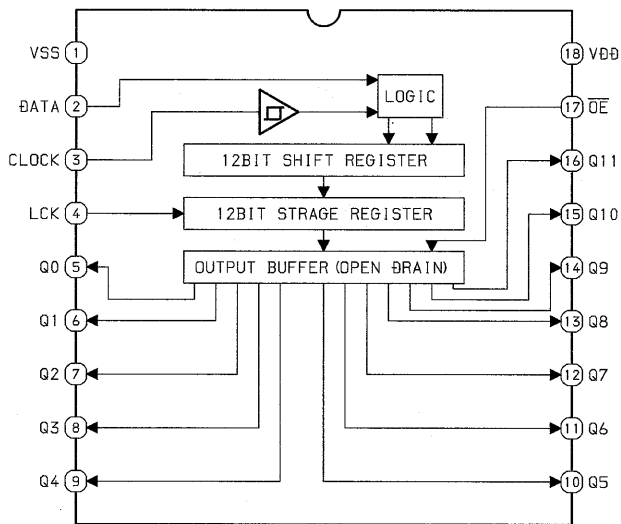

IC, BU4052BC

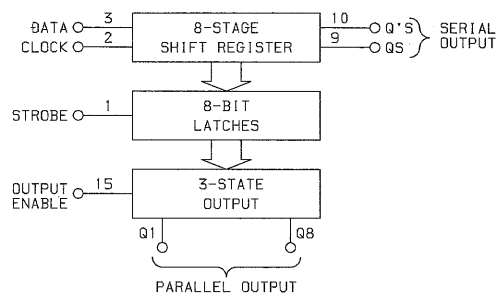
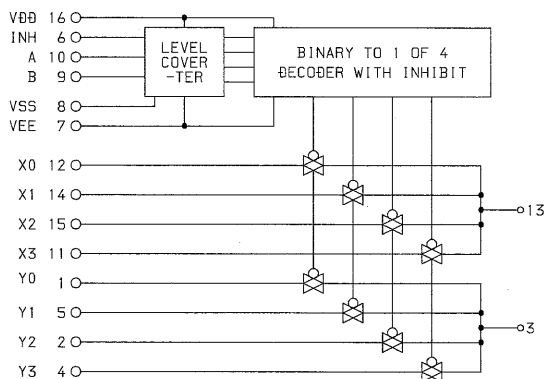

TRUTH TABLE

INHIBIT	A	B	ON SWITCH
L	L	L	X0 Y0
L	H	L	X1 Y1
L	L	H	X2 Y2
L	H	H	X3 Y3
H	X	X	NONE

IC, BU4094B

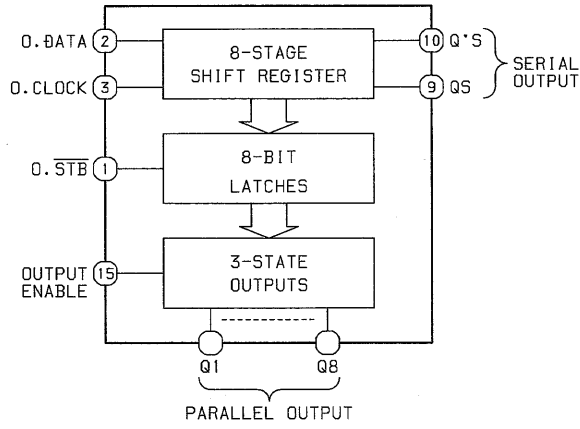

Q1: 0. DOLBY ON Q5: 0. PLAY
 Q2: 0. DOLBY C Q6: 0. PB2
 Q3: 0. EXT. REC Q7: 0. LED
 Q4: 0. INT. REC Q8: 0. RMT

TRUTH TABLE

CLOCK	OUTPUT ENABLE	STROBE	DATA	PARALLEL OUTPUTS		SERIAL OUTPUTS	
				Q1	Qn	QS	Q'S
\bar{f}	L	x	x	Z	Z	Q7	NO CHG.
\bar{f}	L	x	x	Z	Z	NO CHG.	QS
\bar{f}	H	L	x	NO CHG.	NO CHG.	Q7	NO CHG.
\bar{f}	H	H	L	L	Qn-1	Q7	NO CHG.
\bar{f}	H	H	H	H	Qn-1	Q7	NO CHG.
\bar{f}	H	x	x	NO CHG.	NO CHG.	NO CHG.	QS

Z = HIGH IMPEDANCE
 x = DON'T CARE

IC, LA1851N

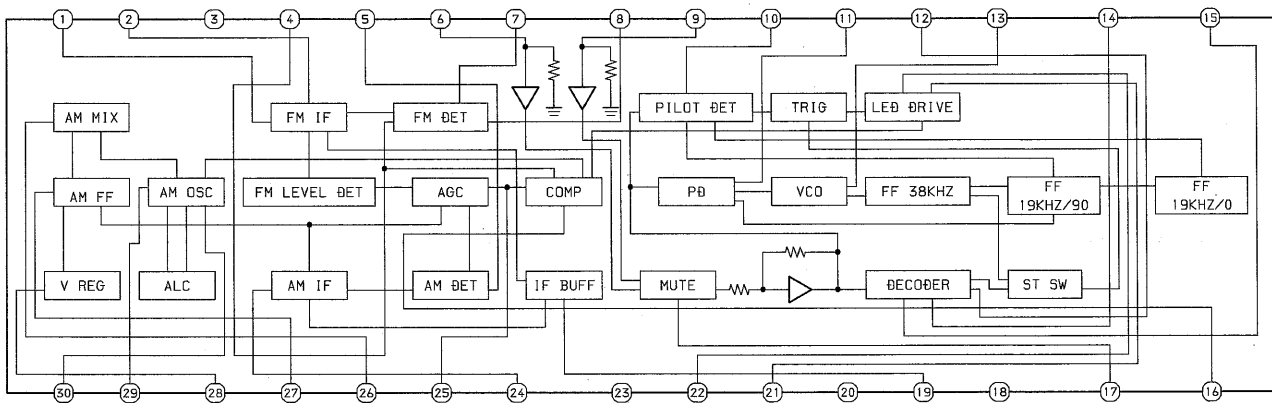

IC, LC7218

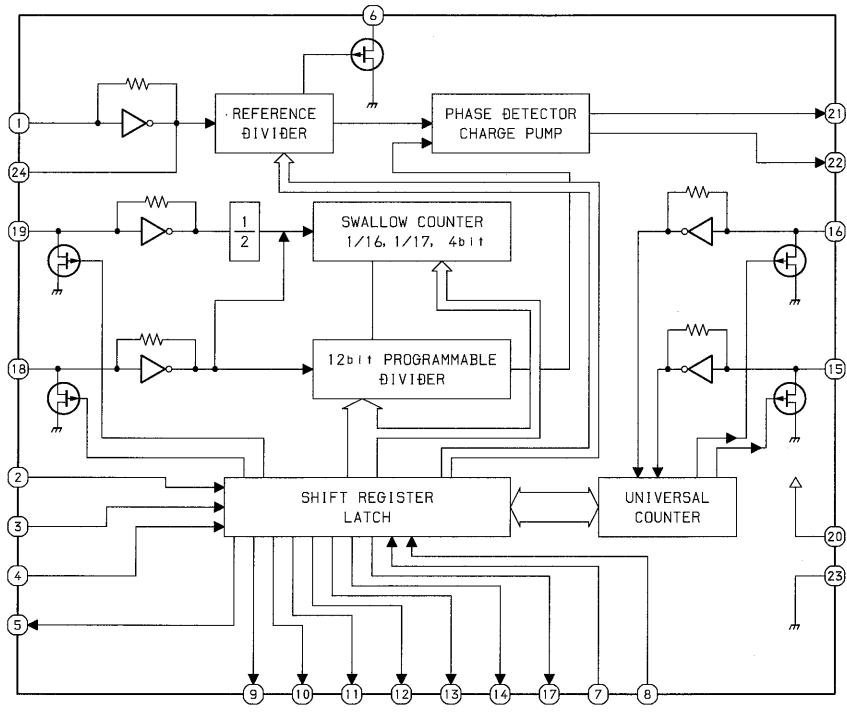

IC, LC7533

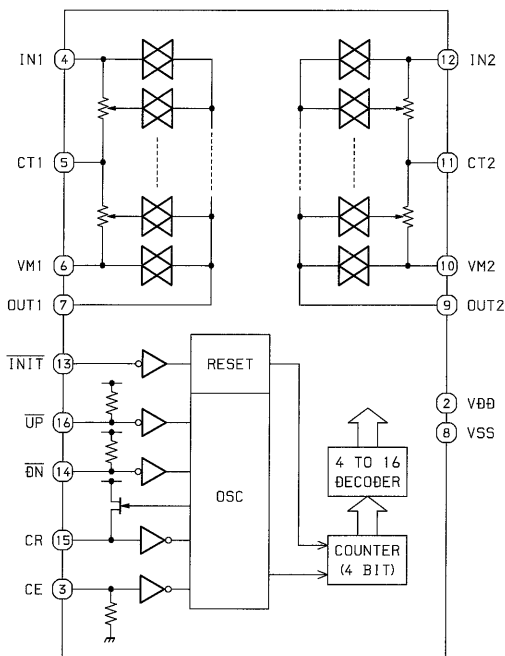

IC, M62412P

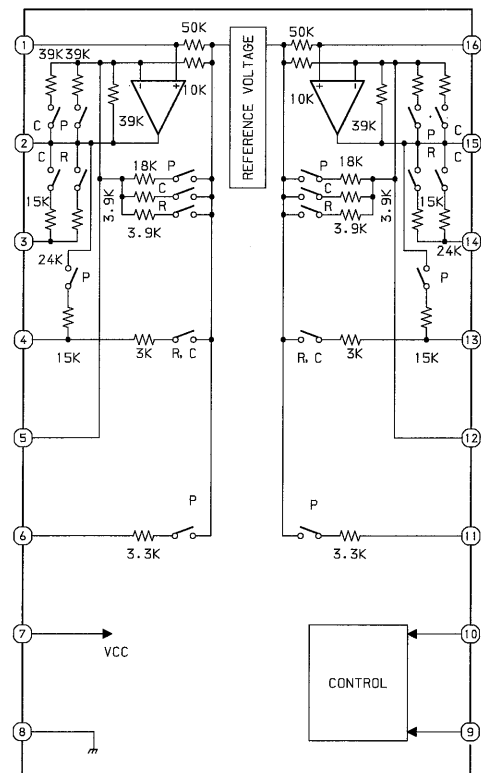

IC, TA2058F

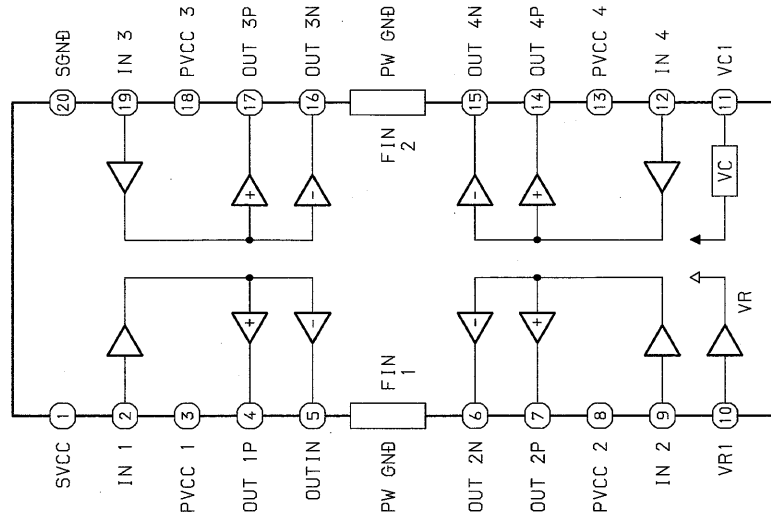

IC, TA7291S

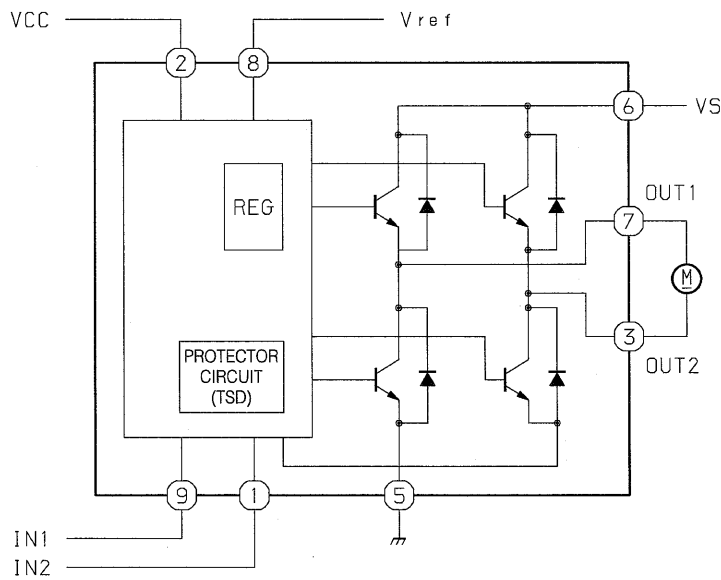

INPUT		OUTPUT		MODE
IN1	IN2	OUT1	OUT2	
0	0	∞	∞	STOP
1	0	H	L	CW/CCW
0	1	L	H	CCW/CW
1	1	L	L	BRAKE

∞ : HI IMPEDANCE
 NOTE : INPUT "H" ACTIVE

IC, TA8126SN

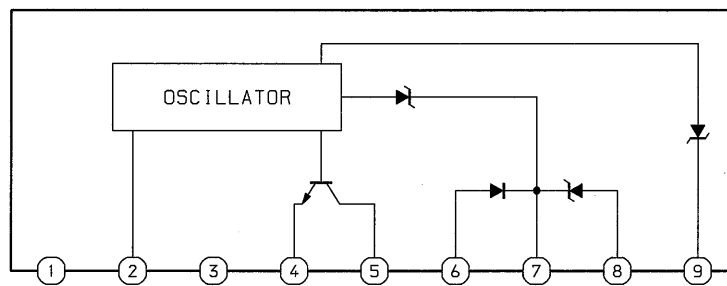

IC, TA8176SN

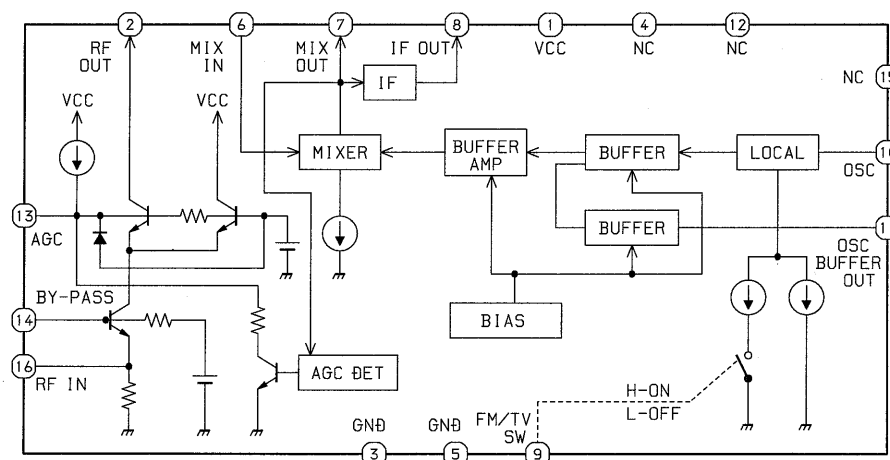

A MAIN C.B

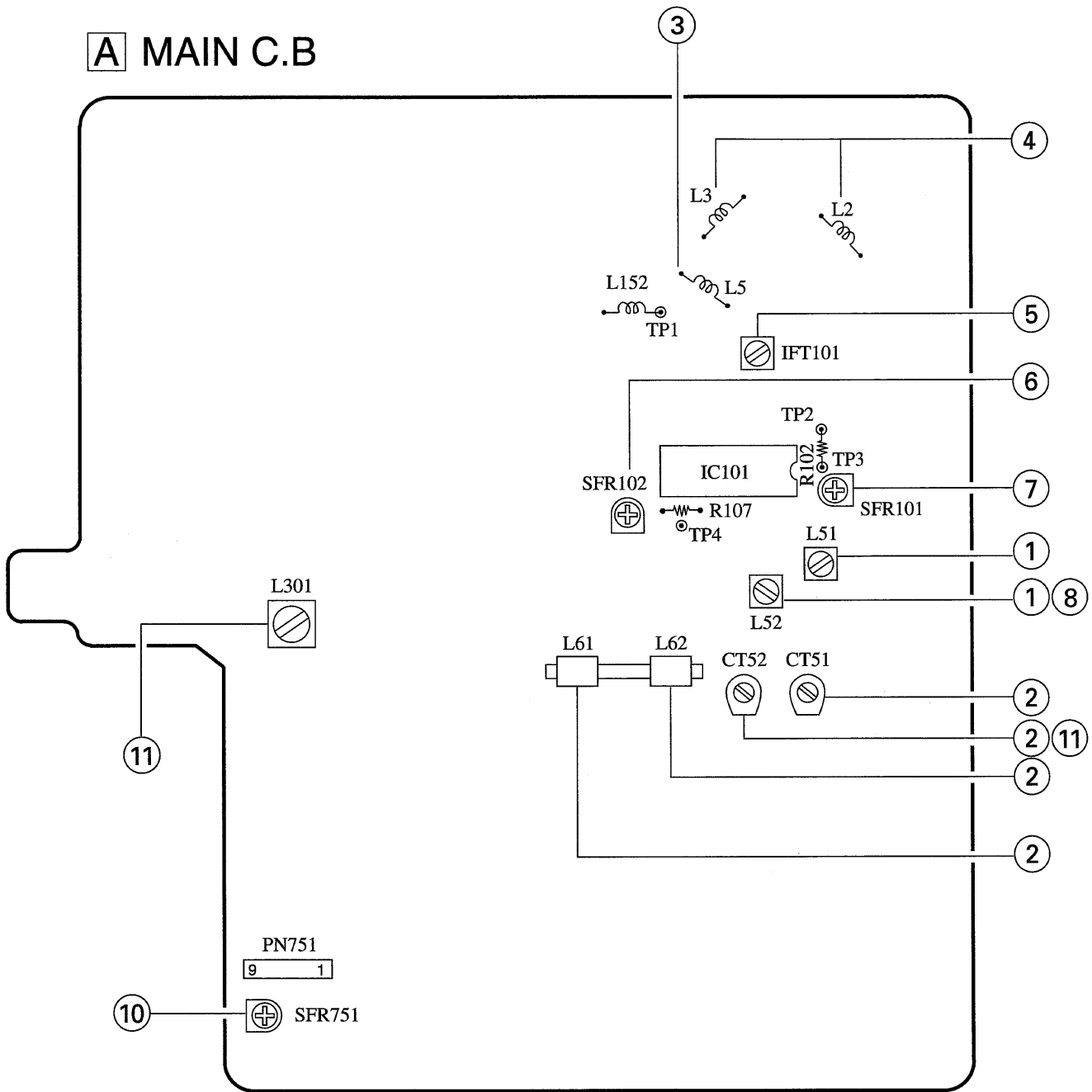

RPH (DECK1) / PH (DECK2)

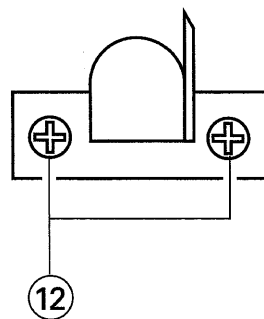

< TUNER SECTION >

1. MW VT Adjustment
Settings: • Test point: TP1
 • Adjustment location: L51
Method: Set to MW 531kHz adjust L51 so that the test point becomes 1.3V.
2. MW Tracking Adjustment
L61 612±10kHz
CT52 1404kHz±10kHz
3. FM VT Adjustment
Settings: • Test point: TP1
 • Adjustment location: L5
Method: Set to FM 87.5kHz so that the test point becomes 4.0V.
4. FM Tracking Adjustment
L2, 3 87.5MHz±0.3MHz
5. DC Balance/MONO Distortion Adjustment
Settings: • Test point: TP2, TP3
 • Adjustment location: IFT101
 • Input level: 54dB
Method: Set to FM 98.0MHz and adjust IFT101 so that the voltage between TP2 and TP3 becomes 0V±10mV.
6. MW Auto Stop Level Adjustment
Settings: • Test point: TP4
SFR102 0V
7. FM Auto Stop Level Adjustment
Settings: • Test point: TP4
SFR101 0V

8. SW VT Adjustment
Settings: • Test point: TP1
 • Adjustment location: L52
Method: Set to SW 3.8MHz adjust L52 so that the test point becomes 1.4V.
9. SW Tracking Adjustment
L62 3.8MHz
CT51 12.5MHz

< TAPE SECTION >

10. Tape speed Adjustment (DECK2)
Settings: • Test tape: TTA-100
 • Adjustment location: SFR751
Method: Play back the test tape with DECK1 and adjust SFR751 so that the output frequency is 3000Hz. After the adjustment, check that the frequency of DECK2 is 2975Hz-3030Hz.
11. BIAS Frequency Adjustment
L301 60kHz
12. Azimuth Adjustment (DECK1, DECK2)
Settings: • Test tape: TTA-320
 • Adjustment location: Head azimuth adjustment screw
Method: Play back the 8kHz signal of the test tape and adjust screw so that the output becomes maximum. Next, perform on each FWD PLAY and REV PLAY mode.

C CD C.B

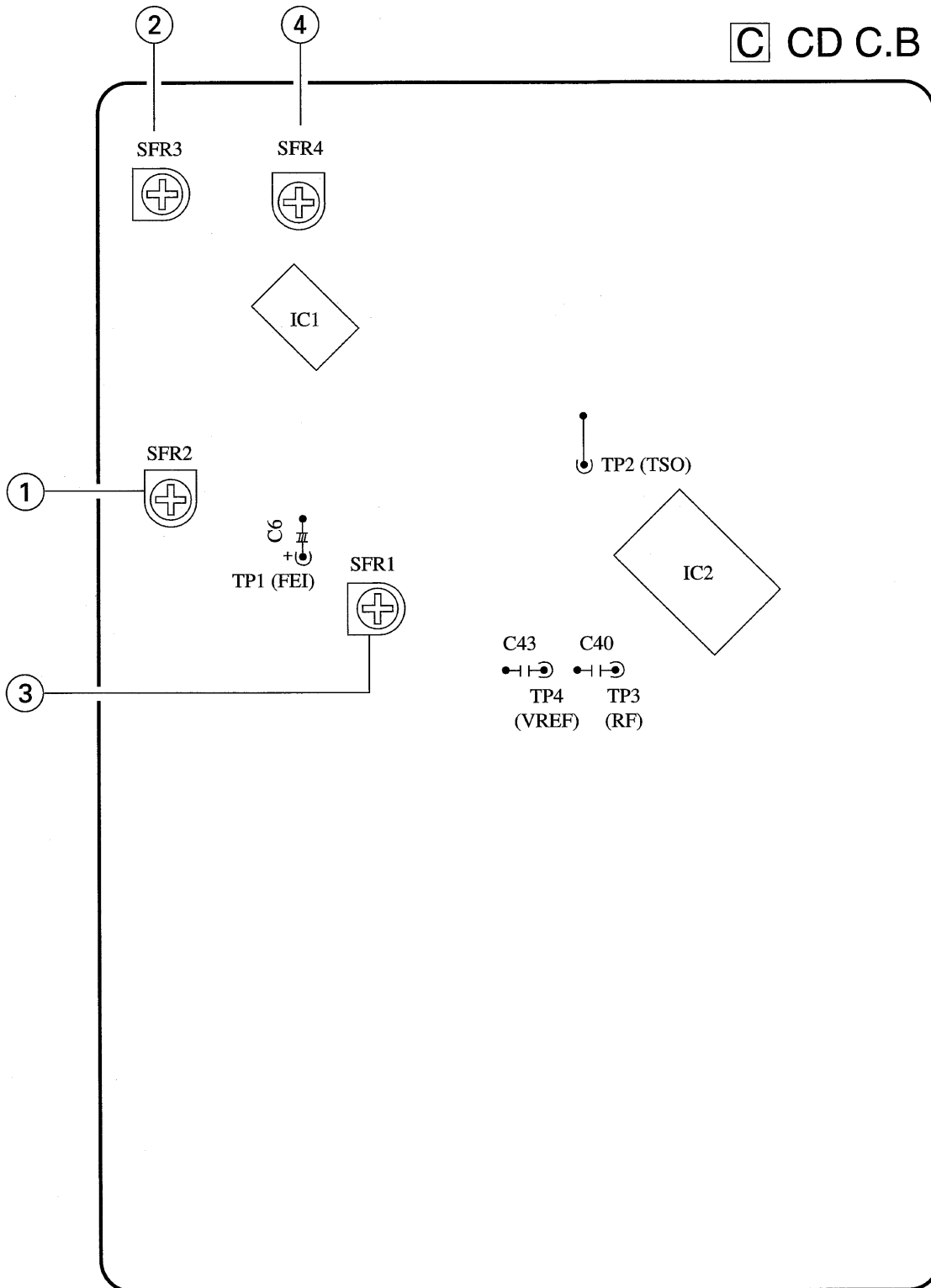

< CD SECTION >

Note: · Connect a probe (10: 1) of the oscilloscope to a test point.

1. Focus offset Adjustment

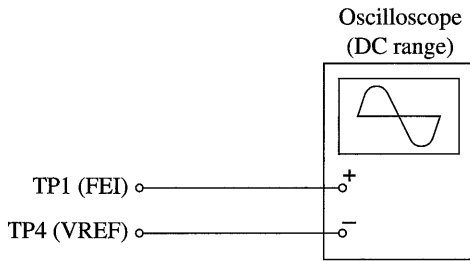

- 1) Make short-circuit between TP3 (RF) and TP4 (VREF) by wire.
- 2) Connect an oscilloscope between test points TP1 (FEL) and TP4 (VREF).
- 3) Turn on the main power to the CD player.
- 4) Insert the test disc TCD-782 and reads the TOC data.
- 5) Adjust SFR2 so that the offset level is $0 \pm 10\text{mV}$.
- 6) Remove short-circuit after completing adjustment.

2. Tracking offset Adjustment

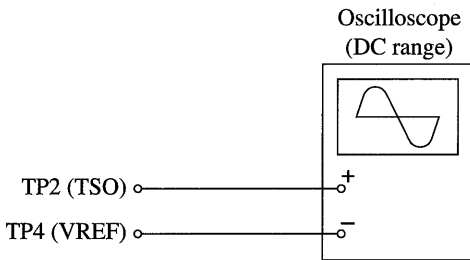

- 1) Make short-circuit between TP3 (RF) and TP4 (VREF) by wire.
- 2) Connect an oscilloscope between test points TP2 (TSO) and TP4 (VREF).
- 3) Turn on the main power to the CD player.
- 4) Insert the test disc TCD-782 and reads the TOC data.
- 5) Adjust SFR3 so that the offset level is $10 \pm 10\text{mV}$.
- 6) Remove short-circuit after completing adjustment.

3. Focus Balance Adjustment

Make the focus bias adjustment when replacing and repairing the optical block.

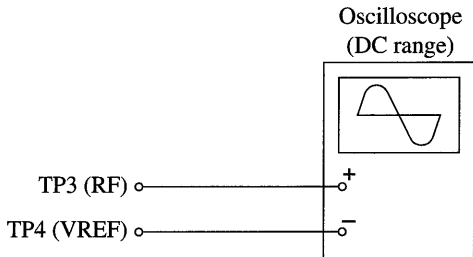

- 1) Connect an oscilloscope to test points TP3 (RF) and TP4 (VREF).
- 2) Turn on the power switch.
- 3) Insert test disc TCD-782 and play back the second composition.
- 4) Adjust SFR1 so that the level of RF wave to be maximum and clear.

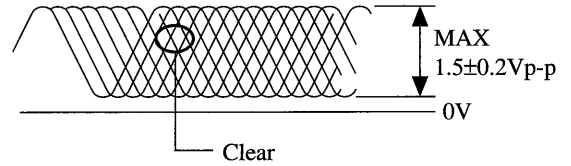

VOLT/DIV: 0.5V
TIME/DIV: 1mS

4. Tracking Balance Adjustment

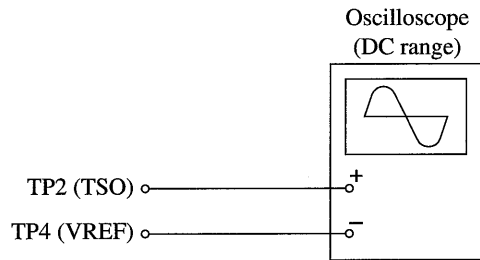

- 1) Connect an oscilloscope to test points TP2 (TSO) and TP4 (VREF).
- 2) Turn on the power switch.
- 3) Insert test disc TCD-782 and press the PLAY (▶) button.
- 4) Push and hold the [MS] button. (MS mode)
- 5) Adjust SFR4 so that the waveform on the oscilloscope is vertically symmetrical as shown in the figure below.

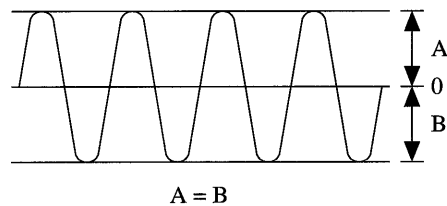

VOLT/DIV: 20mV
TIME/DIV: 1mS

PRACTICAL SERVICE FIGURE

< TUNER SECTION >

< FM SECTION >

Sensitivity: (THD 3%)	19±5dB (87.5/98MHz) 20±5dB (108MHz)
Signal to Noise Ratio: (Input 54dB)	60±5dB (98MHz)
Distortion: (Input 54dB)	Less than 2% (98MHz)
Intermediate frequency:	10.7MHz
Stereo separation:	More than 25dB

< MW SECTION >

Sensitivity: (S/N 10dB)	Less than 50dB±5dB (603kHz) Less than 47dB±5dB (999kHz) Less than 45dB±5dB (1404kHz)
Signal to Noise Ratio:	More than 28dB (603kHz) More than 30dB (999/1404kHz)
Distortion: (Input 74dB)	Less than 5%
Intermediate frequency:	450kHz±1.2kHz

< SW SECTION >

Sensitivity: (S/N 10dB)	Less than 47dB±5dB (3.8MHz) Less than 40dB±5dB (8MHz) Less than 37dB±5dB (12.5MHz)
Signal to Noise Ratio:	More than 34dB (8MHz)

< CASSETTE SECTION >

Tape speed:	3000Hz±90Hz
Wow & flutter:	Less than 0.4% (JIS RMS)
Take-up torque:	30-60g-cm (DECK 1/2)
F.F torque:	55-120g-cm (DECK 1/2)
Rew torque:	55-120g-cm (DECK 1/2)
S/N ratio:	More than 40dB (AC/DC, PB) More than 37dB (AC/DC, REC/PB)
Distortion:	Less than 3.0% (PB)
Noise (PB):	Less than 1mV (AC/DC, MIN)
Erasing Ratio (W/FILTER):	More than 60dB

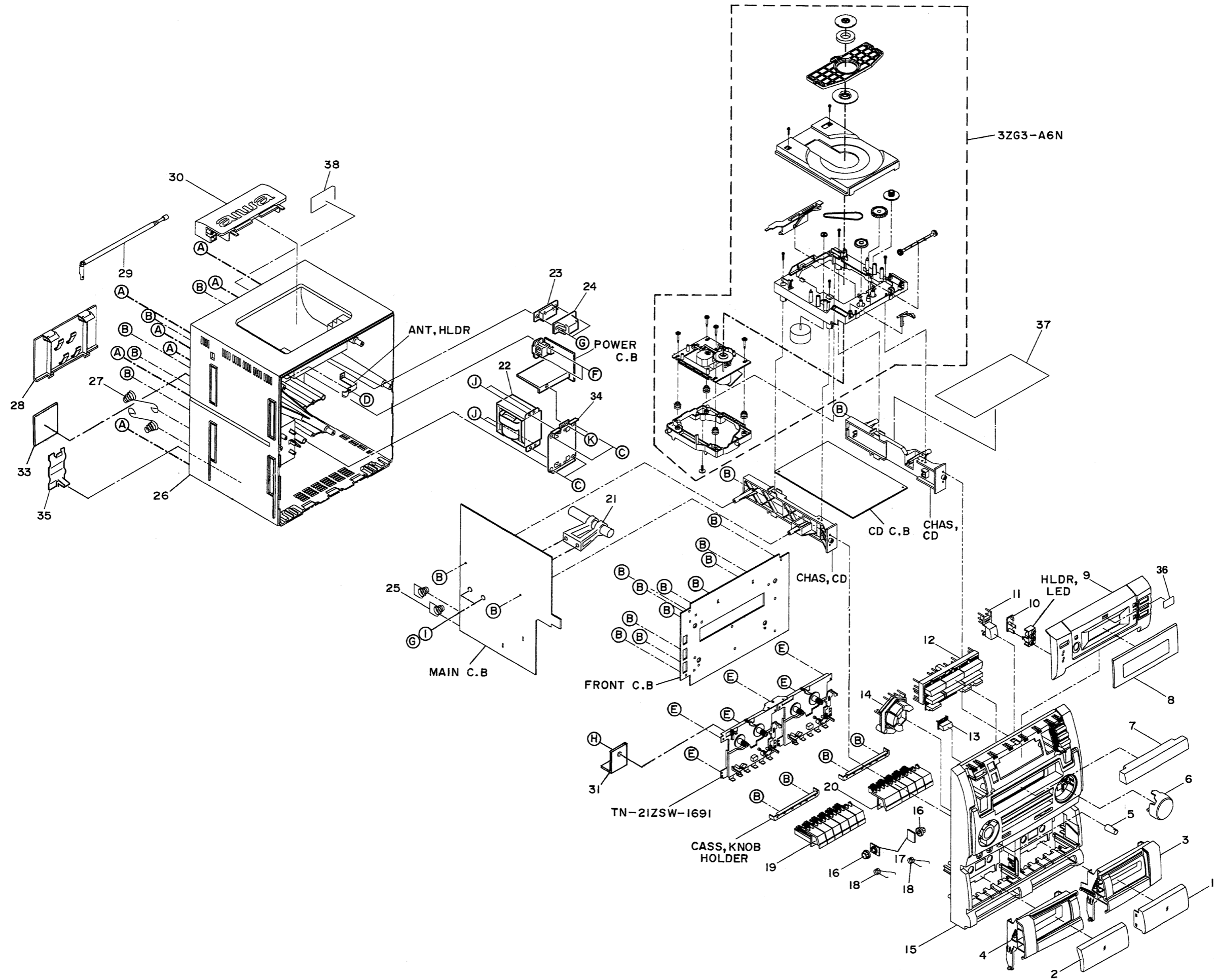

MECHANICAL PARTS LIST 1/1

DESCRIPTIONで判断できない物は "REFERENCE NAME LIST" を参照してください。
 If can't understand for Description please kindly refer to "REFERENCE NAME LIST".

REF. NO	PART NO.	KANRI NO.	DESCRIPTION	REF. NO	PART NO.	KANRI NO.	DESCRIPTION
1	S7-CT4-070-000		LENS, DOOR CASS (R)	25	S7-738-420-000		SPR, BAT (+)
2	S7-CT4-060-000		LENS, DOOR CASS (L)	26	S7-738-500-010		CAB, BACK
3	S7-CT4-040-100		DOOR, CASS (R)	28	S7-738-070-020		DOOR, BATT
4	S7-CT4-030-100		DOOR, CASS (L)	28	S7-738-400-000		SPR, BAT (-)
5	S7-738-130-010		KNOB, MIC	29	87-043-116-010		ROD ANTENNA
6	S7-CT4-130-010		KEY, VOLUME	30	S7-738-050-030		PANEL, TOP
7	S7-CT4-080-100		PANEL, CD	31	S7-CT4-220-000		PLATE, SPR REC
8	S7-CT4-050-100		WINDOW, DISPLAY	33	S7-538-700-000		PLATE, COVER SW VOLTAGE
9	S7-CT4-020-100		PANEL, FRONT	34	S7-CT4-250-000		HOLDER, TF
10	S7-CT4-090-000		LENS, FUNCTION	35	S7-CT4-510-000		COVER, BATT
11	S7-CT4-150-010		KEY, OPEN CD	36	S6-110-550-000		BADGE AIWA
12	S7-CT4-140-100		KEY, CONTROL CD	37	S7-738-500-000		CD PLATE
13	S7-CT4-120-000		KNOB, POWER	38	S7-738-250-000		CD-G PLATE
14	S7-CT4-160-000		KEY, FUNCTION	A	87-741-104-010		SCREW, ST3-30MM PAB
15	S7-CT4-010-300		CAB, FRONT	B	87-352-097-210		SCREW, ST3-12
16	S7-538-280-000		GEAR,	C	87-342-099-210		SCREW ST3-15
17	S7-538-270-000		BRACKET GEAR	D	87-078-157-010		SCREW 3-16
18	S7-CT4-240-000		SPR, CASS	E	87-741-096-410		SCREW, ST3-10MM
19	S7-CT4-170-100		KEY, CASS (L)	F	87-343-075-210		SCREW, ST 2.6-10
20	S7-CT4-180-100		KEY, CASS (R)	G	87-343-075-210		SCREW, 2.6-10
21	S0-101-000-010		FERRI, BAR 10-100M (SW)	H	87-262-547-310		SCREW, 2-3 PM
△ 22	S5-500-031-300		PT, TF EI-66/36 115/230V:15V	I	S0-000-264-500		NUT, M2.6-0.45
22	S7-738-470-000		RUBBER FOOT	J	87-743-094-410		SCREW 3x6
△ 23	S1-200-000-030		SW, SLIDE SS12J01M-A-65	K	87-741-095-410		SCREW, 3-8
24	S2-838-080-000		VOLT, SW COVER				

TAPE MECHANISM EXPLODED VIEW 1/2

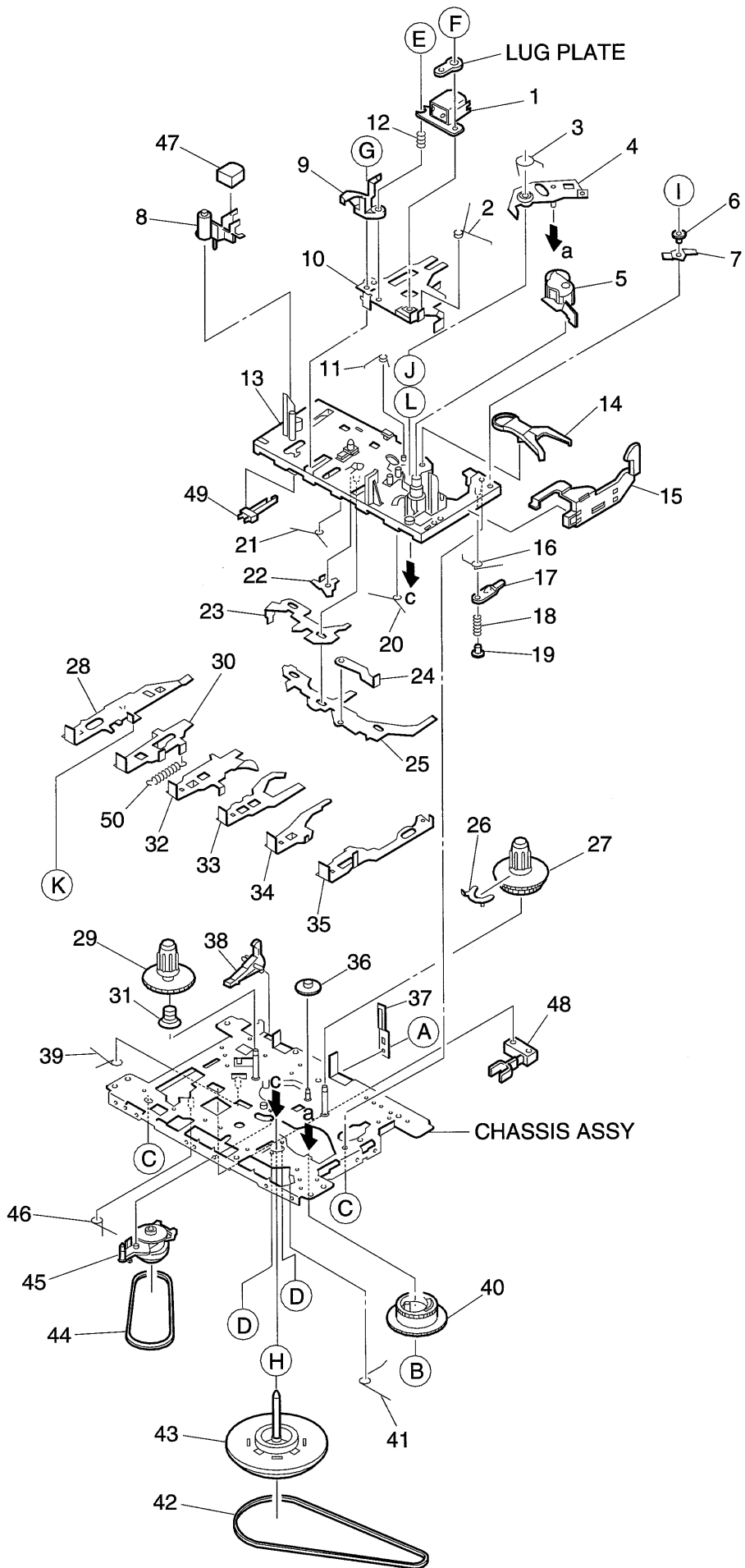

TAPE MECHANISM PARTS LIST 1/2

DESCRIPTIONで判断できない物は "REFERENCE NAME LIST" を参照してください。
If can't understand for Description please kindly refer to "REFERENCE NAME LIST".

REF. NO	PART NO.	KANRI NO.	DESCRIPTION	REF. NO	PART NO.	KANRI NO.	DESCRIPTION
1	S6-201-011-110		HEAD,RP7442ES-0951	31	S1-829-100-100		BACK TENSION SPRING
2	S1-921-030-030		PANEL P SPRING	32	S1-921-140-240		REW BUTTON LEVER
3	S1-921-260-050		GEAR PLATE SPRING	33	S1-921-140-250		FF BUTTON LEVER
4	S1-921-265-020		GEAR PLATE ASSY	34	S1-921-140-260		STOP BUTTON LEVER
5	S1-921-043-090		PINCH ROLLER ARM ASY	35	S1-921-140-610		PAUSE BUTTON LEVER
6	S1-921-140-370		P ARM COLLER	36	S1-821-100-700		FF GEAR
7	S1-921-140-340		P ARM	37	S1-829-100-010		PACK SPRING
8	S1-921-030-050		MG ARM	38	S1-821-100-690		RECORD SAFETY LEVER
9	S1-921-030-4A0		HEAD BASE	39	S1-921-140-210		REC BUTTON LEVER SPRING
10	S1-921-030-110		HEAD PANEL	40	S1-921-260-020		CAM GEAR
11	S1-921-141-8A0		M CONTROL SPRING	41	S1-921-140-160		E ACTUATOR SPRING
12	S1-821-030-070		AZIMUTH SPRING	42	S1-921-090-240		MAIN BELT
13	S1-921-143-010		BASE ASSY	43	S1-921-093-030		FLYWHEEL ASSY
14	S1-921-260-4A0		SENSING LEVER	44	S1-921-070-030		RF BELT
15	S1-921-130-020		EJECT SLIDE LEVER	45	S1-921-073-080		RF CLUTCH ASSY
16	S1-921-141-3A0		P CONTROL SPRING	46	S1-921-140-170		P.S.LEVER SPRING
17	S1-921-140-820		PAUSE LEVER (F)	47	S6-209-100-100		E HEAD PH-K380-MS1
18	S1-921-140-120		PAUSE LEVER SPRING	48	S6-401-011-610		LEAF SW MSW-17820MVEI
19	S1-921-140-110		PAUSE STOPPER	49	S6-401-011-520		LEAF SW MSW-1541F
20	S1-921-140-150		BUTTON LEVER SPRING(B)	50	S1-821-010-500		PLAY BUTTON LEVER SPRING
21	S1-921-140-140		BUTTON LEVER SPRING(A)	A	S9-P33-200-320		DEL TITE SCREWM2-3
22	S1-921-140-200		PR STOPPER	B	S9-422-000-000		P WASHER CUT 12-3.8-0.3
23	S1-921-140-090		SWITCH ACTUATOR	C	S9-679-000-000		P TAP SCREW M2-5
24	S1-821-011-590		E KICK LEVER	D	S9-999-180-090		TAP SCREW M2-4.5
25	S1-921-140-080		PUSH BUTTON ACTUATOR	E	S9-922-000-000		AZIMUTH SCREW M2-8
26	S1-921-050-060		SENSER	F	S9-P01-200-310		SCREW,M2-3
27	S1-921-053-030		TAKE UP REEL ASSY	G	S9-004-000-000		SCREW M2-6
28	S1-921-140-220		REC BUTTON LEVER	H	S9-882-000-000		P WASHER 2-3.5-0.4
29	S1-921-053-040		SUPPLY REEL ASSY	I	S9-999-200-410		P TAP SCREW M2-3
30	S1-921-140-230		PLAY BUTTON LEVER	J	S9-999-030-130		P WASHER CUT 1.45-3.8-0.5
				K	S9-179-000-000		C TAP SCREW M2-3
				L	S9-999-000-030		P WASHER2.1-4-0.13

TAPE MECHANISM EXPLODED VIEW 2/2

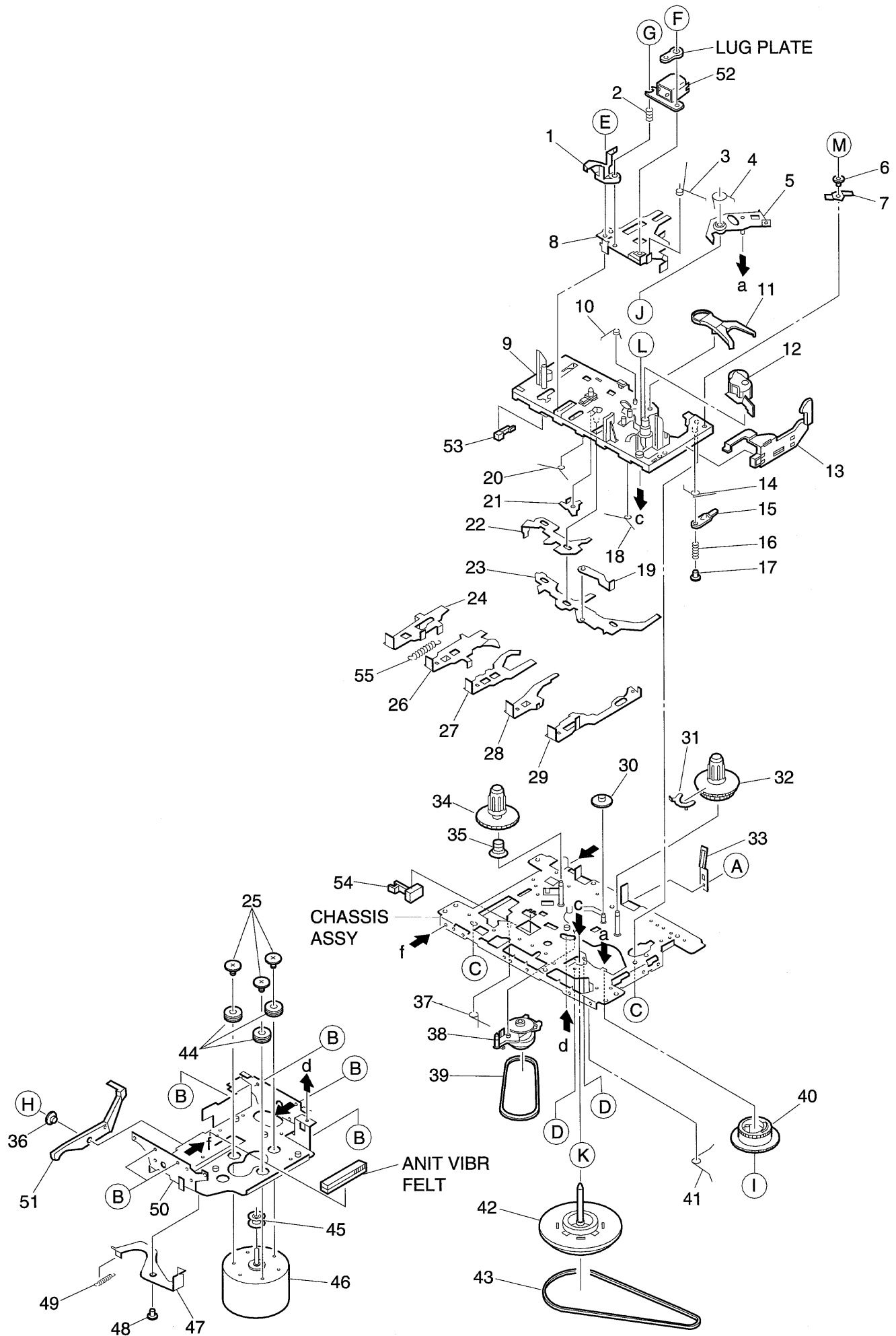

TAPE MECHANISM PARTS LIST 2/2

DESCRIPTIONで判断できない物は "REFERENCE NAME LIST" を参照してください。
 If can't understand for Description please kindly refer to "REFERENCE NAME LIST".

REF. NO	PART NO.	KANRI NO.	DESCRIPTION	REF. NO	PART NO.	KANRI NO.	DESCRIPTION
1	S1-921-030-4A0		HEAD BASE	36	S1-821-120-650		COLLER B
2	S1-821-030-070		AZIMUTH SPRING	37	S1-921-140-170		P.S.LEVER SPRING
3	S1-921-030-030		PANEL P SPRING	38	S1-921-073-080		RF CLUTCH ASSY
4	S1-921-260-050		GEAR PLATE SPRING	39	S1-921-070-030		RF BELT
5	S1-921-265-020		GEAR PLATE ASSY	40	S1-921-260-020		CAM GEAR
6	S1-921-140-370		P ARM COLLER	41	S1-921-140-160		E ACTUATOR SPRING
7	S1-921-140-340		P ARM	42	S1-921-093-040		FLYWHEEL ASSY
8	S1-921-030-110		HEAD PANEL	43	S1-921-090-240		MAIN BELT
9	S1-921-143-010		BASE ASSY	44	S1-820-130-060		MOTOR RUBBER
10	S1-921-141-8A0		M CONTROL SPRING	45	S1-921-120-130		MOTOR PULLEY
11	S1-921-260-4A0		SENSING LEVER	46	S6-002-030-290		MOTOR EG530YD-2BH
12	S1-921-043-090		PINCH ROLLER ARM ASY	47	S1-821-120-680		P KICK LEVER (A)
13	S1-921-130-020		EJECT SLIDE LEVER	48	S1-821-120-230		PK COLLER SCREW A
14	S1-921-141-3A0		P CONTROL SPRING	49	S1-821-120-250		P KICK LEVER SPRING
15	S1-921-140-820		PAUSE LEVER (F)	50	S1-921-120-110		MOTOR BRACKET
16	S1-921-140-120		PAUSE LEVER SPRING	51	S1-921-120-090		P KICK LEVER
17	S1-921-140-110		PAUSE STOPPER	52	S6-201-011-110		HEAD,RP7442ES-0951
18	S1-921-140-150		BUTTON LEVER SPRING(B)	53	S6-401-011-520		LEAF SW MSW-1541F
19	S1-821-011-590		E KICK LEVER	54	S6-401-011-610		LEAF SW MSW-17820MVEI
20	S1-921-140-140		BUTTON LEVER SPRING(A)	55	S1-821-010-500		PLAY BUTTON LEVER SPRING
21	S1-921-140-200		PR STOPPER	A	S9-P33-200-320		DEL TITE SCREWM2-3
22	S1-921-140-090		SWITCH ACTUATOR	B	S9-180-000-000		C TAP SCREW M2-4
23	S1-921-140-080		PUSH BUTTON ACTUATOR	C	S9-679-000-000		P TAP SCREW M2-5
24	S1-921-140-230		PLAY BUTTON LEVER	D	S9-999-180-090		TAP SCREW M2-4.5
25	S1-821-120-020		MOTOR COLLER SCREW	E	S9-004-000-000		SCREW M2-6
26	S1-921-140-240		REW BUTTON LEVER	F	S9-P01-200-310		SCREW,M2-3
27	S1-921-140-250		FF BUTTON LEVER	G	S9-922-000-000		AZIMUTH SCREW M2-8
28	S1-921-140-260		STOP BUTTON LEVER	H	S9-182-000-000		C TAP SCREW M2-6
29	S1-921-140-610		PAUSE BUTTON LEVER	I	S9-422-000-000		P WASHER CUT 12-3.8-0.3
30	S1-821-100-700		FF GEAR	J	S9-999-030-130		P WASHER CUT 1.45-3.8-0.5
31	S1-921-050-060		SENSOR	K	S9-882-000-000		P WASHER 2-3.5-0.4
32	S1-921-053-030		TAKE UP REEL ASSY	L	S9-999-000-030		P WASHER2.1-4-0.13
33	S1-829-100-010		PACK SPRING	M	S9-999-200-410		P TAP SCREW M2-3
34	S1-921-053-040		SUPPLY REEL ASSY				
35	S1-829-100-100		BACK TENSION SPRING				

CD MECHANISM EXPLODED VIEW 1/2

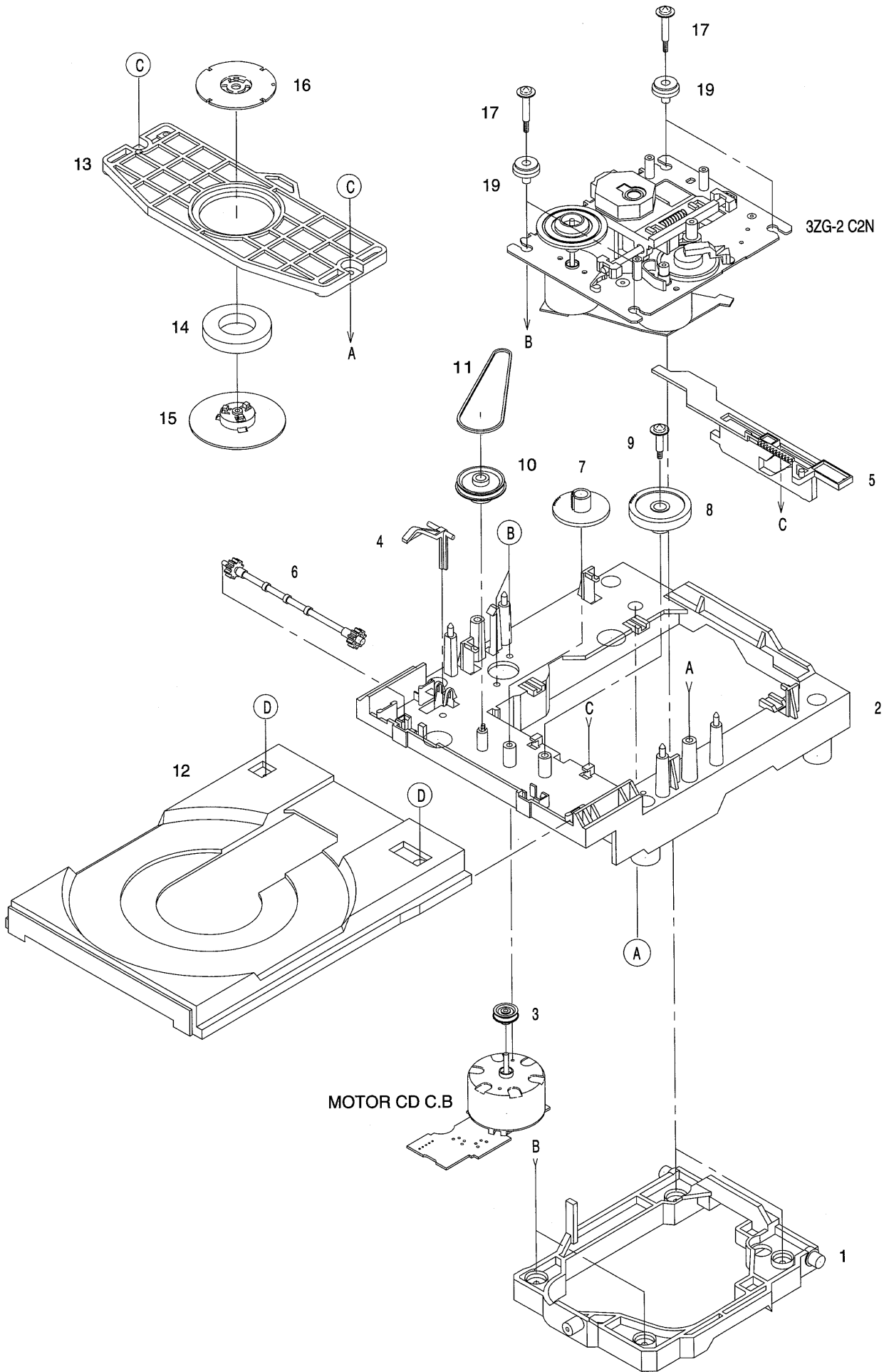

CD MECHANISM PARTS LIST 1/2

DESCRIPTIONで判断できない物は "REFERENCE NAME LIST" を参照してください。
 If can't understand for Description please kindly refer to "REFERENCE NAME LIST".

REF. NO	PART NO.	KANRI NO.	DESCRIPTION	REF. NO	PART NO.	KANRI NO.	DESCRIPTION
1	83-ZG3-224-119		HLDR, M2	16	83-ZG3-211-01K		PLATE, DISC
2	83-ZG3-228-21K		CHAS, L6	17	81-ZG1-254-019		S-SCEW, MECH HLDR
3	83-ZG3-208-01K		PULLEY, MOTOR	19	83-ZG3-225-019		CUSH-G, MAIN A
4	83-ZG3-213-01K		LVR, SW	A	87-067-945-119		VFT2+3-12 (F10)
5	83-ZG3-209-01K		CAM, SLIDE	B	87-251-071-119		U+2.6-4
6	83-ZG3-207-01K		GEAR, TRAY	C	87-512-074-219		VFT2+2.6-8
7	83-ZG3-204-01K		GEAR, C	D	87-352-075-219		VT2+2.6-10
8	83-ZG3-205-01K		GEAR, D				
9	83-ZG3-217-019		S-SCREW, GEAR D				
10	83-ZG3-220-11K		GEAR, PULLEY 2				
11	83-ZG3-214-019		BELT, L				
12	83-ZG3-229-01K		TRAY, CD 2				
13	83-ZG3-210-01K		HLDR, CHUCK				
14	83-ZG3-602-010		RING, MAG				
15	83-ZG3-212-01K		CAP, DISC				

CD MECHANISM EXPLODED VIEW 2/2

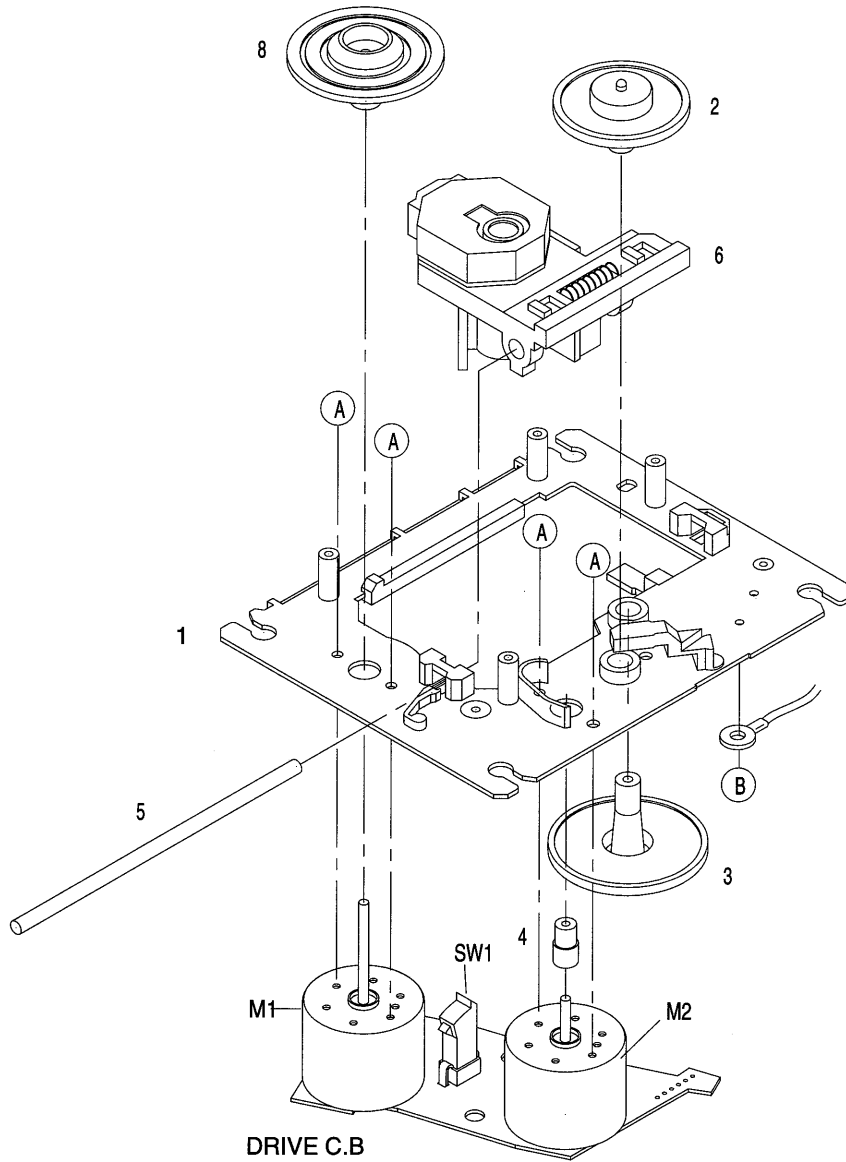

CD MECHANISM PARTS LIST 2/2

DESCRIPTIONで判断できない物は "REFERENCE NAME LIST" を参照してください。
 If can't understand for Description please kindly refer to "REFERENCE NAME LIST".

REF. NO	PART NO.	KANRI NO.	DESCRIPTION
1	83-ZG2-202-71K		O-SERT S ASSY, S
2	83-ZG2-204-419		GEAR, A
3	83-ZG2-205-219		GEAR, B
4	83-ZG2-220-01K		GEAR MOTOR 2
5	83-ZG2-240-019		SHAFT, SLIDE 3
6	87-070-109-019		KSS 212A, PICKUP UNIT
8	83-ZG2-233-019		TURN TABLE, A5
A	87-261-032-219		SCREW V+2-3
B	87-067-174-019		SCRE VTT+2-4

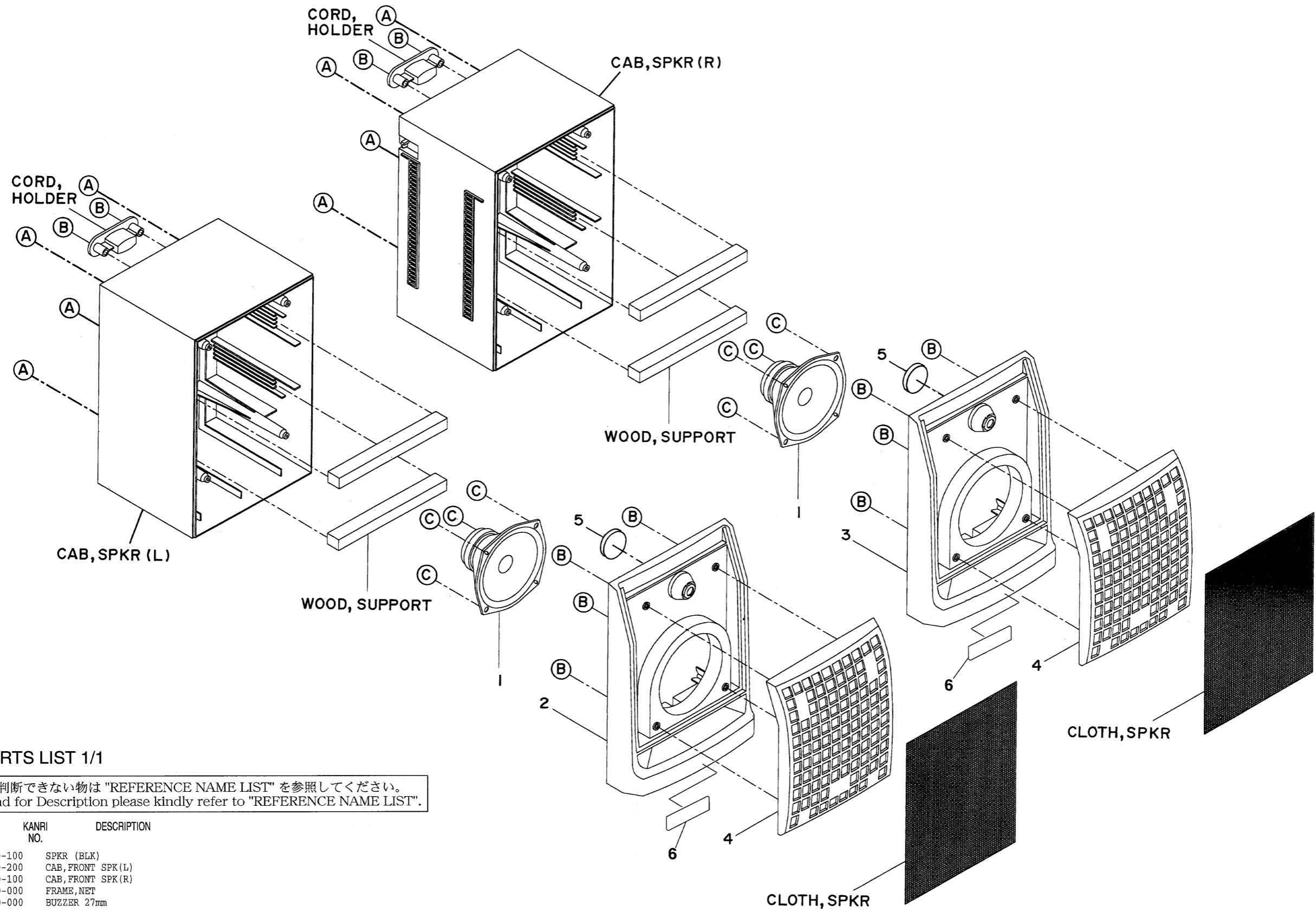

SPEAKER PARTS LIST 1/1

DESCRIPTIONで判断できない物は "REFERENCE NAME LIST" を参照してください。
 If can't understand for Description please kindly refer to "REFERENCE NAME LIST".

REF. NO	PART NO.	KANRI NO.	DESCRIPTION
1	S5-040-180-100		SPKR (BLK)
2	S7-CT4-100-200		CAB, FRONT SPK (L)
3	S7-CT4-100-100		CAB, FRONT SPK (R)
4	S7-CT4-110-000		FRAME, NET
5	S3-270-010-000		BUZZER 27mm
6	S0-410-210-000		LOGO AIWA
A	87-342-099-210		SCREW ST 3-15
B	87-352-097-210		SCREW, ST3-12
C	87-661-097-410		SCREW ST3-12

ACCESSORIES/PACKAGE LIST

DESCRIPTIONで判断できない物は "REFERENCE NAME LIST" を参照してください。
If can't understand for Description please kindly refer to "REFERENCE NAME LIST".

REF. NO	PART NO.	KANRI NO.	DESCRIPTION
	1	S7-CT4-910-310	INSTRUCTION BOOK (S2/S4HE)
△	3	S2-201-100-000	POWER CORD (E)
△	4	S0-220-117-000	CONVERTOR 220V-117V

REFERENCE NAME LIST

ELECTRICAL SECTION

DESCRIPTION	REFERENCE NAME
ANT	ANTENNAS
C-	CHIP
C-CAP	CAP, CHIP
C-CAP TN	CAP, CHIP TANTALUM
C-COIL	COIL, CHIP
C-DI	DIODE, CHIP
C-DIODE	DIODE, CHIP
C-FET	FET, CHIP
C-FOTR	FILTER, CHIP
C-JACK	JACK, CHIP
C-LED	LED, CHIP
C-RES	RES, CHIP
C-SFR	SFR, CHIP
C-SLIDE SW	SLIDE SWITCH, CHIP
C-SW	SWITCH, CHIP
C-TR	TRANSISTOR, CHIP
C-VR	VOLUME, CHIP
C-ZENER	ZENER, CHIP
CAP, CER	CAP, CERA-SOL
CAP, E	CAP, ELECT
CAP, M/F	CAP, FILM
CAP, TC	CAP, CERA-SOL
CAP, TC-U	CAP, CERA-SOL SS
CAP, TN	CAP, TANTALUM
CERA FIL	FILTER, CERAMIC
CF	FILTER, CERAMIC
DL	DELAY LINE
E/CAP	CAP, ELECT
FILT	FILTER
FLTR	FILTER
FUSE RES	RES, FUSE
MOT	MOTOR
P-DIODE	PHOTO DIODE
P-SNSR	PHOTO SENSER
P-TR	PHOTO TRANSISTOR
POLY VARI	VARIABLE CAPACITOR
PPCAP	CAP, PP
PT	POWER TRANSFORMER
PTR, RES	PTR, MELF
RC	REMOTE CONTROLLER
RES NF	RES, NON-FLAMMABLE
RESO	RESONATOR
SHLD	SHIELD
SOL	SOLENOID
SPKR	SPEAKER
SW, LVR	SWITCH, LEVER
SW, RTRY	SWITCH, ROTARY
SW, SL	SWITCH, SLIDE
TC CAP	CAP, CERA-SOL
THMS	THERMISTOR
TR	TRANSISTOR
TRIMMER	CAP, TRIMMER
TUN-CAP	VARIABLE CAPACITOR
VIB, CER	RESONATOR, CERAMIC
VIB, XTAL	RESONATOR, CRYSTAL
VR	VOLUME
ZENER	DIODE, ZENER

MECHANICAL SECTION

DESCRIPTION	REFERENCE NAME
ADHESHIVE	SHEET ADHESHIVE
AZ	AZIMUTH
BAR-ANT	BAR-ANTENNA
BAT	BATTERY
BATT	BATTERY
BRG	BEARING
BTN	BUTTON
CAB	CABINET
CASS	CASSETTE
CHAS	CHASSIS
CLR	COLLAR
CONT	CONTROL
CRSR	CURSOR
CU	CUSHION
CUSH	CUSHION
DIR	DIRECTION
DUBB	DUBBING
FL	FRONT LOADING
FLY-WHL	FLYWHEEL
FR	FRONT
FUN	FUNCTION
G-CU	G-CUSHION
HDL	HANDOL
HIMERON	CLOTH
HINGE, BAT	HINGE, BATTERY
HLDR	HOLDER
HT-SINK	HEAT SINK
IB	INSTRUCTION BOOKLET
IDLE	IDLER
IND, L-R	INDICATOR, L-R
KEY, CONT	KEY, CONTROL
KEY, PRGM	KEY, PROGRAM
KNOB, SL	KNOB, SLIDE
LBL	LABEL
LID, BATT	LID, BATTERY
LID, CASS	LID, CASSETTE
LVR	LEVER
P-SP	P-SPRING
PANEL, CONT	PANEL, CONTROL
PANEL, FR	PANEL, FRONT
PRGM	PROGRAM
PULLY, LOAD MO	PULLY, LOAD MOTOR
RBN	RIBBON
S-	SPECIAL
SEG	SEGMENT
SH	SHEET
SHLD-SH	SHIELD-SHEET
SL	SLIDE
SP	SPRING
SP-SCREW	SPECIAL-SCREW
SPACER, BAT	SPACER, BATTERY
SPR	SPRING
SPR-P	P-SPRING
SPR-PC-PUSH	P-SPRING, C-PUSH
T-SP	T-SPRING
TERM	TERMINAL
TRIG	TRIGGER
TUN	TUNING
VOL	VOLUME
W	WASHER
WHL	WHEEL
WORM-WHL	WORM-WHEEL

サービス技術ニュース	
番号	連絡内容
G- -	
G- -	
G- -	

アイワ株式会社
AIWA CO., LTD.

912162

Tokyo Japan