

aiwa



NSX-A50

NSX-A51

NSX-A54

NSX-S50

NSX-S52

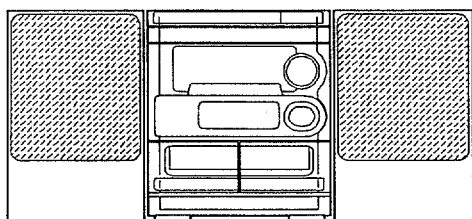

COMPACT DISC STEREO
CASSETTE RECEIVER

- BASIC TAPE MECHANISM : 2ZM-3MK2 PR4NM
- BASIC CD MECHANISM : 4ZG-1 Z1DNM

- TYPE : U<A50/51/54>,
LH<S50>,HR<S52>

SYSTEM	SPEAKER	CD - CASSEIVER
NSX-A50 (TYPE : U)	SX - NA54	CX - NA50
NSX-A54 (TYPE : U)	SX - NA54 SX - R210	
NSX-A51 (TYPE : U)	SX - FNA51	CX - NA51
NSX-S50 (TYPE : LH)	SX - FNS50	CX - NS50
NSX-S52 (TYPE : HR)	SX - ANS70	CX - NS52

•If requiring information about the CD mechanism, see Service Manual of 4ZG-1, S/M Code No. 09-974-187-50T.

•If requiring information about the Speaker, see Service Manual of SX-R210, S/M Code No. 09-974-186-2FE.

TABLE OF CONTENTS

SPECIFICATIONS	3, 4
PROTECTION OF EYES FROM LASER BEAM DURING SERVICING	5
PRECAUTION TO REPLACE OPTICAL BLOCK	5
ELECTRICAL MAIN PARTS LIST	6 ~ 9
TRANSISTOR ILLUSTRATION	10
BLOCK DIAGRAM	11, 12
WIRING - 1 (MAIN : A50U,A54U)	13, 14
SCHEMATIC DIAGRAM - 1 (MAIN : A50U,A54U)	15 ~ 17
SCHEMATIC DIAGRAM - 2 (MAIN : A51U)	18 ~ 20
WIRING - 2 (MAIN : A51U)	21, 22
WIRING - 3 (MAIN : LH)	23, 24
SCHEMATIC DIAGRAM - 3 (MAIN : LH)	25~ 27
SCHEMATIC DIAGRAM - 4 (MAIN : HR)	28~ 30
WIRING - 4 (MAIN : HR)	31, 32
WIRING - 5 (FRONT : A50U,A54U)	33, 34
SCHEMATIC DIAGRAM - 5 (FRONT : A50U,A54U)	35 ~ 37
SCHEMATIC DIAGRAM - 6 (FRONT : A51U,LH,HR)	38 ~ 40
WIRING - 6 (FRONT : A51U,LH,HR)	41, 42
SCHEMATIC DIAGRAM - 7 (TUNER FRONT END)	43
WIRING - 7 (AC)	44
WIRING - 8 (DECK)	45
FL GRID ASSIGNMENT & ANODE CONNECTION	46, 47
IC BLOCK DIAGRAM - 1	48, 49
IC DESCRIPTION	50 ~ 52
IC BLOCK DIAGRAM - 2	53
ADJUSTMENT	54, 55
PRACTICAL SERVICE FIGURE	56
MECHANICAL EXPLODED VIEW 1 / 1	57, 58
MECHANICAL PARTS LIST 1 / 1	59
ACCESSORIES / PACKAGE LIST	59
TAPE MECHANISM EXPLODED VIEW 1 / 1	60, 61
TAPE MECHANISM PARTS LIST 1 / 1	62
SPEAKER PARTS LIST	63
SPRING APPLICATION POSITION	64
REFERENCE NAME LIST	65

SPECIFICATIONS

<FM Tuner section>

Tuning range 87.5 MHz to 108 MHz
Usable sensitivity (IHF) 13.2 dBf
Antenna terminals 75 ohms (unbalanced)

<AM/MW Tuner section>

Tuning range 531 kHz to 1602 kHz (9 kHz step)
 530 kHz to 1710 kHz (10 kHz step)
Usable sensitivity 350 μ V/m
Antenna Loop antenna

<SW Tuner section>

Tuning range HR : 5.900 MHz ~ 17.900 MHz
Antenna Wire antenna

<Amplifier section>

Power output A50U,A51U,A54U :
 60 W + 60 W (50 Hz - 20 kHz,
 THD less than 1%, 6 ohms)
 LH :
 Rated : 120 W + 120 W
 (6 ohms, T.H.D. 10%, 1 kHz)
 HR :
 Rated : 100 W + 100 W
 (6 ohms, T.H.D. 1%, 1 kHz)
 Reference : 120 W + 120 W
 (6 ohms, T.H.D. 10%, 1 kHz)

Total harmonic distortion

A50U,A51U,A54U :
 0.05% (50 W, 1 kHz, 6 ohms,
 DIN AUDIO)
 LH :
 0.05% (70W, 1 kHz, 6 ohms,
 DIN AUDIO)
 HR :
 0.05% (70 W, 1 kHz, 6 ohms,
 DIN AUDIO)

Inputs

A50U,A51U,A54U :
 VIDEO/AUX : 150 mV (adjustable)
 MD : 150 mV (adjustable)
 A50U,A54U :
 MIC : 1.8 mV (10 kohms)
 A51U :
 MIC : 1 mV (10 kohms)
 LH :
 VIDEO /AUX : 210 mV (adjustable)
 MD : 210 mV (adjustable)
 MIC1,MIC2 : 1.4 mV (10 kohms)
 HR :
 VIDEO /AUX : 210 mV (adjustable)
 MD : 210 mV (adjustable)
 MIC : 1.4 mV (10 kohms)

Outputs

LINE OUT : 200 mV
 A50U,A51U,A54U :
 SUPER WOOFER : 1.9 V
 LH :
 SUPER WOOFER : 2.7 V
 HR :
 SUPER WOOFER : 2.6 V
 SPEAKERS: accept speakers of
 6 ohms or more
 SURROUND SPEAKERS :
 accept speakers of 16 ohms or
 more
 PHONES (stereo jack) :
 accepts headphones of 32 ohms
 or more

<Cassette deck section>

Track format 4 tracks, 2 channels stereo
Frequency response CrO2 tape : 50 Hz - 16000 Hz
 Normal tape : 50 Hz - 15000 Hz
Recording system AC bias
Heads Deck 1 : Playback head x 1
 Deck 2 : Recording/playback/
 erase head x 1

<Compact disc player section>

Laser Semiconductor laser ($\lambda = 780$ nm)
D-A converter 1 bit dual
Signal-to-noise ratio 85 dB (1 kHz, 0 dB)
Harmonic distortion 0.05% (1 kHz, 0 dB)
Wow and flutter Unmeasurable

<Speaker system SX-NA54> (A50U,A54U)

Cabinet type 3 way, bass reflex
 (magnetic shielded type)
Speakers Woofer :
 160 mm (6³/₈ in.) cone type
 Tweeter :
 60 mm (2³/₈ in.) cone type
 Super tweeter :
 20 mm (1³/₁₆ in.) ceramic type
Impedance 6 ohms
Output sound pressure level 87 dB/W/m
Dimensions (W x H x D) 243 x 304 x 245 mm
 (9⁵/₈ x 12 x 9³/₄ in.)
Weight 3.3 kg (7 lbs 4 oz.)

<Speaker system SX-FNA51> (A51U)

Cabinet type 3 way, bass reflex with surround
 speaker (magnetic shielded type)
Speakers Woofer :
 160 mm (6³/₈ in.) cone type
 Tweeter :
 80 mm (3¹/₄ in.) cone type
 Super tweeter :
 20 mm (1³/₁₆ in.) ceramic type
 Surround speaker :
 80 mm (3¹/₄ in.)
Impedance Front speaker : 6 ohms
 Surround speaker : 16 ohms
Output sound pressure level 87 dB/W/m
Dimensions (W x H x D) 250 x 304 x 288 mm
 (9⁷/₈ x 12 x 11³/₈ in.)
Weight 3.6 kg (7 lbs 15 oz.)

<Speaker system SX-FNS50> (LH)

Cabinet type 3 way, bass reflex with surround
 speaker (magnetic shielded type)
Speakers Woofer :
 160 mm cone type
 Tweeter :
 80 mm cone type
 Super tweeter :
 20 mm ceramic type
 Surround speaker :
 80 mm cone type
Impedance Front speaker : 6 ohms
 Surround speaker : 16 ohms
Output sound pressure level 87 dB/W/m
Dimensions (W x H x D) 250 x 304 x 288 mm
Weight 3.6 kg

<Speaker system SX-ANS70> (HR)

Cabinet type 4 way, bass reflex with surround
 speaker (magnetic sealed type)
Speakers Woofer :
 160 mm cone type
 Tweeter :
 50 mm cone type
 Super tweeter :
 20 mm ceramic type
 Cardioid speaker :
 80 mm cone type
 Surround speaker :
 80 mm cone type
Impedance Front speaker : 6 ohms
 Surround speaker : 16 ohms
Output sound pressure level 87 dB/W/m
Dimensions (W x H x D) 250 x 310 x 280 mm
Weight 4.5 kg

<General>

Power requirements	A50U,A51U,A54U : 120 V AC, 60Hz LH,HR : 120 V / 220 – 230 V / 240 V AC, switchable ,50 / 60 Hz
Power consumption	A50U,A51U,A54U : 95 W LH,HR : 140 W
Dimensions of main unit (W x H x D)	260 x 309 x 346 mm (10 ¹ / ₄ x 12 ¹ / ₄ x 13 ⁵ / ₈ in.)
Weight of main unit	A50U,A51U,A54U : 6.5 kg (14 lbs 5 oz.) LH,HR : 7.2 kg

- Design and specifications are subject to change without notice.
- The word "BBE" and the "BBE symbol" are trademarks of BBE Sound, Inc.
Under license from BBE Sound, Inc.

PROTECTION OF EYES FROM LASER BEAM DURING SERVICING

This set employs laser. Therefore, be sure to follow carefully the instructions below when servicing.

WARNING!!

WHEN SERVICING, DO NOT APPROACH THE LASER EXIT WITH THE EYE TOO CLOSELY. IN CASE IT IS NECESSARY TO CONFIRM LASER BEAM EMISSION, BE SURE TO OBSERVE FROM A DISTANCE OF MORE THAN 30cm FROM THE SURFACE OF THE OBJECTIVE LENS ON THE OPTICAL PICK-UP BLOCK.

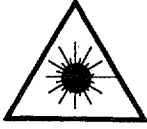

- Caution: Invisible laser radiation when open and interlocks defeated avoid exposure to beam.
- Advarsel: Usynlig laserstråling ved åbning, når sikkerhedsafbrydere er ude af funktion. Undgå udsættelse for stråling.

VAROITUS!

Laiteen Käyttäminen muulla kuin tässä käyttöohjeessa mainitulla tavalla saattaa altistaa käyttäjän turvallisuusluokan 1 ylitävälle näkymättömälle lasersäteilylle.

WARNING!

Om apparaten används på annat sätt än vad som specificeras i denna bruksanvisning, kan användaren utsättas för osynlig laserstrålning, som överskrider gränsen för laserklass 1.

CAUTION

Use of controls or adjustments or performance of procedures other than those specified herein may result in hazardous radiation exposure.

ATTENTION

L'utilisation de commandes, réglages ou procédures autres que ceux spécifiés peut entraîner une dangereuse exposition aux radiations.

ADVARSEL!

Usynlig laserstråling ved åbning, når sikkerhedsafbrydere er ude af funktion. Undgå udsættelse for stråling.

This Compact Disc player is classified as a CLASS 1 LASER product.

The CLASS 1 LASER PRODUCT label is located on the rear exterior.

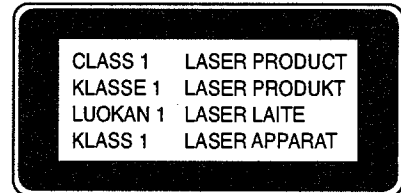

Precaution to replace Optical block

(KSS – 213B)

Body or clothes electrostatic potential could ruin laser diode in the optical block. Be sure ground body and workbench, and use care the clothes do not touch the diode.

- 1) After the connection, remove solder shown in figure below.

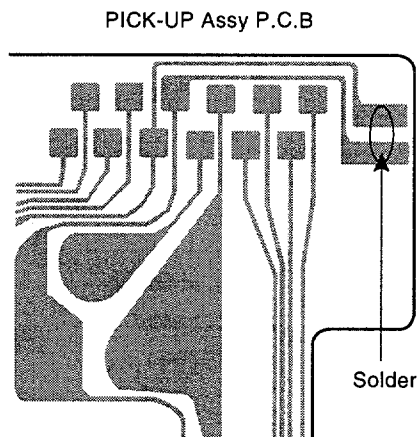

ELECTRICAL MAIN PARTS LIST

If can't understand for Description please kindly refer to "REFERENCE NAME LIST".

REF. NO.	PART NO.	KANRI NO.	DESCRIPTION	REF. NO.	PART NO.	KANRI NO.	DESCRIPTION
IC				C107	87-012-368-080		C-CAP,S 0.1-50 Z F
				C108	87-012-368-080		C-CAP,S 0.1-50 Z F
	87-NF4-641-010		IC,LC866548V-5E15				
	87-A20-448-010		IC,PIC-21043TE3	C109	87-010-196-080		C-CAP,S 0.1-25 Z F C2012
	87-A20-501-040		C-IC,BA7762FS	C110	87-010-196-080		C-CAP,S 0.1-25 Z F C2012
	87-A20-083-010		IC,BA3835S	C111	87-010-196-080		C-CAP,S 0.1-25 Z F C2012
	87-A20-450-040		C-IC,BH3864F	C112	87-010-196-080		C-CAP,S 0.1-25 Z F C2012
				C113	87-010-384-080		CAP,E 100-25 M SME<EXP LH,HR>
	87-A20-056-010		IC,BA3880S				
	87-A20-451-040		C-IC,BU9262FS<EXP 50U,54U>	C113	87-010-247-080		CAP,E 100-50 M SME<LH,HR>
	87-A20-456-040		C-IC,BH3810FS	C116	87-010-384-080		CAP,E 100-25 M SME<EXP LH,HR>
	87-017-888-080		C-IC,NJM4558MD	C116	87-010-247-080		CAP,E 100-50 M SME<LH,HR>
	86-NFZ-655-010		IC,LC72131D(Z)	C117	87-010-430-080		CAP,E 100-63 M SME
				C118	87-010-263-080		CAP,E 100-10 SME
	87-A20-438-010		IC,LA1837				
	87-020-454-010		IC,DN6851	C119	87-010-260-080		CAP,E 47-25 SME
				C120	87-010-403-080		CAP,E 3.3-50 M SME
				C121	87-012-140-080		C-CAP,S 470P-50 J CH
TRANSISTOR				C122	87-010-263-080		CAP,E 100-10 SME<EXP LH,HR>
				C123	87-010-382-080		CAP,E 22-25 M SME<50U,54U>
	87-026-263-080		C-TR,RN1410				
	89-213-702-010		TR,2SB1370E	C123	87-010-247-080		CAP,100-50 M SME<51U,LH,HR>
	87-A30-076-080		C-TR,2SC3052F	C124	87-010-112-080		CAP,E 100-16 M SME
	87-A30-075-080		C-TR,2SA1235F	C125	87-010-235-080		CAP,E 470-16 SME
	87-026-610-080		TR,KTC3198GR	C129	87-010-393-080		CAP,E 100-35 M SME
				C201	87-010-401-080		CAP,E 1-50 M SME
	87-A30-073-080		C-TR,RT1N 141C				
	87-A30-085-070		C-TR,CSA1362GR	C202	87-010-401-080		CAP,E 1-50 M SME
	87-A30-083-080		TR,CSD1489B	C205	87-010-181-080		C-CAP,S 1800P-50KB<51U,LH,HR>
	87-A30-084-080		TR,CSB1058B	C205	87-010-182-080		C-CAP,S 2200P-50KB<50U,54U>
	87-A30-071-080		C-TR,RT1N 144C	C206	87-010-181-080		C-CAP,S 1800P-50KB<51U,LH,HR>
				C206	87-010-182-080		C-CAP,S 2200P-50KB<50U,54U>
	87-026-609-080		TR,KTA1266GR				
	87-A30-086-070		C-TR,CSD1306E	C207	87-010-404-080		CAP,E 4.7-50 M SME
	87-A30-106-070		C-TR,CMBT5551	C208	87-010-404-080		CAP,E 4.7-50 M SME
	87-A30-111-080		TR,C2N5401	C209	87-010-404-080		CAP,E 4.7-50 M SME
	87-A30-097-010		TR,FN1016	C210	87-010-404-080		CAP,E 4.7-50 M SME
				C211	87-010-186-080		C-CAP,S 4700P-50 K B
	87-A30-098-010		TR,FP1016				
	87-A30-089-010		FET,2SK2723	C212	87-010-186-080		C-CAP,S 4700P-50 K B
	87-A30-072-080		C-TR,RT1P 144C	C213	87-010-260-080		CAP,E 47-25 SME
	87-A30-087-080		C-FET,2SK2158	C214	87-010-260-080		CAP,E 47-25 SME
	87-A30-074-080		C-TR,RT1P 141C	C215	87-010-196-080		C-CAP,S 0.1-25 Z F C2012
				C219	87-010-196-080		C-CAP,S 0.1-25 Z F C2012
	89-327-143-080		C-TR,2SC2714(O)				
	89-505-434-540		C-TR,2SK543-TB (4/5)<HR>	C220	87-010-196-080		C-CAP,S 0.1-25 Z F C2012
	87-026-463-080		TR,2SA933S	C221	87-010-196-080		C-CAP,S 0.1-25 Z F C2012
				C222	87-010-196-080		C-CAP,S 0.1-25 Z F C2012
				C223	87-010-194-080		C-CAP,S 0.047-25 Z F
				C225	87-010-322-080		C-CAP,S 100P-50 J CH
DIODE							
	87-A40-270-080		C-DIODE,MC2838	C226	87-010-322-080		C-CAP,S 100P-50 J CH
	87-A40-116-060		DIODE,RS403L-B-D-51<EXP LH,HR>	C242	87-010-405-080		CAP,E 10-50 M SME<50U,54U>
	87-A40-115-060		DIODE,RS603M<LH,HR>	C242	87-010-382-080		CAP,E 22-50 M SME<51U,LH,HR>
	87-017-437-080		DIODE,1N4148M	C243	87-010-197-080		CAP,S 0.01-25 K B
	87-A40-246-080		DIODE,1N4148T-72	C301	87-010-318-080		C-CAP,S 47P-50 J CH
	87-A40-269-080		C-DIODE,MC2836	C302	87-010-318-080		C-CAP,S 47P-50 J CH
	87-070-274-080		DIODE,1N4003 SEM	C303	87-012-157-080		C-CAP,S 330P-50 J CH GRM
	87-A40-344-080		ZENER,MTZJ6.2C	C304	87-012-157-080		C-CAP,S 330P-50 J CH GRM
	87-A40-341-080		ZENER,MTZJ36A	C305	87-012-145-080		C-CAP,S 270P-50 J CH
	87-A40-345-080		ZENER,MTZJ10C	C306	87-012-145-080		C-CAP,S 270P-50 J CH
	87-070-136-080		ZENER,MTZJ5.1B	C307	87-010-196-080		C-CAP,S 0.1-25 Z F C2012
	87-070-178-090		DIODE,1N5402-BD54<EXP LH,HR>	C309	87-010-196-080		C-CAP,S 0.1-25 Z F C2012
	87-026-681-080		DIODE,RK 34(F)<LH,HR>	C310	87-010-196-080		C-CAP,S 0.1-25 Z F C2012
	87-017-931-080		ZENER,MTZJ5.6B	C311	87-010-198-080		C-CAP,S 0.022-25 K B
	87-A40-003-080		ZENER,MTZJ4.3A	C312	87-010-198-080		C-CAP,S 0.022-25 K B
	87-A40-234-080		ZENER,MTZJ5.6A	C313	87-010-178-080		C-CAP,S 1000P-50 K B
				C314	87-010-178-080		C-CAP,S 1000P-50 K B
				C315	87-010-178-080		C-CAP,S 1000P-50 K B
				C316	87-010-178-080		C-CAP,S 1000P-50 K B
				C321	87-016-492-080		C-CAP,S 0.33-16 Z F
MAIN C.B							
C101	87-010-917-090		CAP,E 3300-50 M SMG<EXP LH,HR>				
C101	87-016-520-090		CAP,E 3300-65 M SMG<LH,HR>	C322	87-016-492-080		C-CAP,S 0.33-16 Z F
C102	87-010-917-090		CAP,E 3300-50 M SMG<EXP LH,HR>	C324	87-010-260-080		CAP,E 47-25 SME
C102	87-016-520-090		CAP,E 3300-65 M SMG<LH,HR>	C325	87-010-370-080		CAP,E 330-6.3 M SME
C103	87-010-453-090		CAP,E 4700-25 SME	C327	87-010-404-080		CAP,E 4.7-50 M SME
				C328	87-010-404-080		CAP,E 4.7-50 M SME
C104	87-010-453-090		CAP,E 4700-25 SME				
C105	87-012-368-080		C-CAP,S 0.1-50 Z F	C332	87-010-196-080		C-CAP,S 0.1-25 Z F C2012
C106	87-012-368-080		C-CAP,S 0.1-50 Z F	C335	87-010-401-080		CAP,E 1-50 M SME

REF. NO.	PART NO.	KANRI NO.	DESCRIPTION	REF. NO.	PART NO.	KANRI NO.	DESCRIPTION
C336	87-010-401-080		CAP,E 1-50 M SME	C721	87-010-312-080		C-CAP,S 15P-50 J CH
C337	87-010-196-080		C-CAP,S 0.1-25 Z F C2012	C722	87-010-312-080		C-CAP,S 15P-50 J CH
C339	87-010-196-080		C-CAP,S 0.1-25 Z F C2012	C723	87-010-178-080		C-CAP,S 1000P-50 K B
C340	87-010-196-080		C-CAP,S 0.1-25 Z F C2012	C725	87-010-178-080		C-CAP,S 1000P-50 K B
C351	87-012-140-080		C-CAP,S 470P-50 J CH	C727	87-010-196-080		C-CAP,S 0.1-25 Z F C2012
C352	87-012-140-080		C-CAP,S 470P-50 J CH	C728	87-010-248-080		CAP,E 220-10 SME
C354	87-010-175-080		C-CAP,S 560P-50 J SL	C755	87-010-197-080		C-CAP,S 0.01-25 K B
C355	87-012-349-080		C-CAP,S 1000P-50 J CH	C756	87-010-197-080		C-CAP,S 0.01-25 K B
C356	87-010-260-080		CAP,E 47-25 SME	C757	87-010-318-080		C-CAP,S 47P-50 J CH
C357	87-010-197-080		C-CAP,S 0.01-25 K B	C758	87-010-149-080		C-CAP,S 5P-50 CH
C358	87-010-183-080		C-CAP,S 2700P-50 K B	C761	87-010-196-080		C-CAP,S 0.1-25 Z F C2012
C359	87-010-183-080		C-CAP,S 2700P-50 K B	C762	87-010-197-080		C-CAP,S 0.01-25 K B
C360	87-010-183-080		C-CAP,S 2700P-50 K B	C763	87-010-194-080		C-CAP,S 0.047-25 Z F
C370	87-010-196-080		C-CAP,S 0.1-25 Z F C2012	C765	87-010-197-080		C-CAP,S 0.01-25 K B
C373	87-010-993-080		C-CAP,S 0.056-25 K B MK212	C766	87-010-197-080		C-CAP,S 0.01-25 K B
C374	87-010-993-080		C-CAP,S 0.056-25 K B MK212	C767	87-010-405-080		CAP,E 10-50 M SME
C378	87-010-196-080		C-CAP,S 0.1-25 Z F C2012	C768	87-010-197-080		C-CAP,S 0.01-25 K B
C379	87-010-382-080		CAP,E 22-25 M SME	C769	87-010-408-080		CAP,E 47-50 SME
C380	87-010-382-080		CAP,E 22-25 M SME	C770	87-015-821-080		C-CAP, 0.047-50 Z F GR
C381	87-010-197-080		C-CAP,S 0.01-25 K B	C771	87-010-407-080		CAP,E 33-50 SME
C382	87-010-312-080		C-CAP,S 15P-50 J CH	C772	87-010-194-080		C-CAP,S 0.047-25 Z F
C383	87-010-197-080		C-CAP,S 0.01-25 K B	C773	87-010-196-080		C-CAP,S 0.1-25 Z F C2012
C384	87-010-402-080		CAP,E 2.2-50 M SME	C774	87-010-263-080		CAP,E 100-10 SME
C386	87-010-196-080		C-CAP,S 0.1-25 Z F C2012	C775	87-010-404-080		CAP,E 4.7-50 M SME
C387	87-012-145-080		C-CAP,S 270P-50 J CH	C776	87-010-197-080		C-CAP,S 0.01-25 K B<EXP HR>
C388	87-010-154-080		C-CAP,S 10P-50 D CH	C777	87-010-400-080		CAP,E 0.47-50 M SME
C401	87-010-187-080		C-CAP,S 5600P-50 K B	C778	87-010-401-080		CAP,E 1-50 M SME
C402	87-010-187-080		C-CAP,S 5600P-50 K B	C779	87-010-401-080		CAP,E 1-50 M SME
C403	87-010-405-080		CAP,E 10-50 M SME	C780	87-010-196-080		C-CAP,S 0.1-25 Z F C2012
C404	87-010-405-080		CAP,E 10-50 M SME	C781	87-010-405-080		CAP,E 10-50 M SME
C405	87-010-260-080		CAP,E 47-25 SME	C782	87-010-405-080		CAP,E 10-50 M SME
C406	87-010-101-080		CAP,E 220-16 SME	C783	87-015-819-080		C-CAP,0.01-50 K B
C407	87-010-188-080		C-CAP,S 6800P-50 K B	C784	87-010-197-080		C-CAP,S 0.01-25 K B
C408	87-010-188-080		C-CAP,S 6800P-50 K B	C785	87-010-400-080		CAP,E 0.47-50 M SME
C409	87-012-140-080		C-CAP,S 470P-50 J CH	C786	87-010-400-080		CAP,E 0.47-50 M SME
C410	87-012-140-080		C-CAP,S 470P-50 J CH	C787	87-010-184-080		C-CAP,S 3300P-50 K B
C411	87-010-197-080		C-CAP,S 0.01-25 K B	C788	87-010-184-080		C-CAP,S 3300P-50 K B
C412	87-010-197-080		C-CAP,S 0.01-25 K B	C789	87-010-179-080		C-CAP,S 1200P-50 K B
C413	87-010-195-080		C-CAP,S 0.068-25 Z F C2012	C790	87-010-179-080		C-CAP,S 1200P-50 K B
C414	87-010-195-080		C-CAP,S 0.068-25 Z F C2012	C791	87-010-405-080		CAP,E 10-50 M SME
C415	87-010-404-080		CAP,E 4.7-50 M SME	C793	87-010-178-080		C-CAP,S 1000P-50 K B
C416	87-010-404-080		CAP,E 4.7-50 M SME	C794	87-010-406-080		CAP,E 22-50 M SME
C417	87-010-404-080		CAP,E 4.7-50 M SME	C795	87-010-596-080		C-CAP,S 0.047-16 R K
C418	87-010-404-080		CAP,E 4.7-50 M SME	C796	87-010-403-080		CAP,E 3.3-50 M SME
C421	87-010-401-080		CAP,E 1-50 M SME	C797	87-010-182-080		C-CAP,S 2200P-50KB<EXP HR>
C422	87-010-401-080		CAP,E 1-50 M SME	C797	87-010-180-080		C-CAP,S 1500P-50 K B<HR>
C516	87-010-196-080		C-CAP,S 0.1-25 Z F C2012	C798	87-010-182-080		C-CAP,S 2200P-50 K B
C605	87-010-180-080		C-CAP,S 1500P-50 K B	C799	87-010-194-080		C-CAP,S 0.047-25 Z F
C606	87-010-180-080		C-CAP,S 1500P-50 K B	C812	87-010-197-080		C-CAP,S 0.01-25 K B
C611	87-010-196-080		C-CAP,S 0.1-25 Z F C2012	C814	87-010-197-080		C-CAP,S 0.01-25 K B
C613	87-010-404-080		CAP,E 4.7-50 M SME	C820	87-010-408-080		CAP,E 47-50 SME
C614	87-010-404-080		CAP,E 4.7-50 M SME	C821	87-010-197-080		C-CAP,S 0.01-25 K B
C615	87-010-183-080		C-CAP,S 2700P-50 K B	C822	87-010-197-080		C-CAP,S 0.01-25 K B
C619	87-010-263-080		CAP,E 100-10 SME	C823	87-010-197-080		C-CAP,S 0.01-25 K B
C620	87-010-196-080		C-CAP,S 0.1-25 Z F C2012	C828	87-010-196-080		C-CAP,S 0.1-25 Z F C2012
C621	87-010-263-080		CAP,E 100-10 SME	C829	87-010-196-080		C-CAP,S 0.1-25 Z F C2012
C622	87-010-196-080		C-CAP,S 0.1-25 Z F C2012	C940	87-010-197-080		C-CAP,S 0.01-25 K B<HR>
C623	87-010-194-080		C-CAP,S 0.047-25 Z F	C941	87-010-314-080		C-CAP,S 22P-50 J CH<HR>
C629	87-010-196-080		C-CAP,S 0.1-25 Z F<51U,HR>	C943	87-010-197-080		C-CAP, S 0.01-25 K B<HR>
C646	87-010-322-080		C-CAP,S 100P-50J C H	C944	87-014-051-080		CAP,PP 560P-100 J<HR>
C647	87-010-322-080		C-CAP,S 100P-50J C H	C945	87-010-197-080		C-CAP,S 0.01-25 K B<HR>
C701	87-010-381-080		CAP,E 330-16 SME	C947	87-010-197-080		C-CAP,S 0.01-25 K B<HR>
C702	87-010-404-080		CAP,E 4.7-50 M SME	C950	87-014-073-080		CAP,PP 4700P-100 J<HR>
C703	87-010-197-080		C-CAP,S 0.01-25 K B	C952	87-010-197-080		C-CAP,S 0.01-25 K B<HR>
C704	87-010-197-080		C-CAP,S 0.01-25 K B	C953	87-010-197-080		C-CAP,S 0.01-25 K B<HR>
C711	87-010-263-080		CAP,E 100-10 SME	C954	87-010-400-080		CAP,E 0.47-50 M SME<HR>
C712	87-010-196-080		C-CAP,S 0.1-25 Z F C2012	C956	87-010-263-080		CAP,E 100-10 SME<HR>
C713	87-010-197-080		C-CAP,S 0.01-25 K B	C962	87-010-401-080		CAP,E 1-50 M SME<HR>
C714	87-010-197-080		C-CAP,S 0.01-25 K B	C959	87-010-196-080		C-CAP,S 0.1-25 Z F C2012

REF. NO.	PART NO.	KANRI NO.	DESCRIPTION	REF. NO.	PART NO.	KANRI NO.	DESCRIPTION
C960	87-010-196-080		C-CAP, S 0.1-25 Z F C2012	C116	87-010-494-040		CAP, E 1-50 5L SRE
C961	87-010-152-080		C-CAP, S 8P-50 D CH<EXP HR>	C117	87-010-550-040		CAP, E 100-6.3 5L SRE
CF801	87-008-261-010		FLTR, CFSFE10.7MA5	C118	87-010-194-080		C-CAP, S 0.047-25 Z F
CF802	87-008-261-010		FLTR, CFSFE10.7MA5	C119	87-010-408-040		CAP, E 47-50 M SME
F201	87-026-690-080		FUSE, 5A 125V 251<50U, 51U, 54U>	C120	87-010-404-040		CAP, E 4.7-50 SME
F202	87-026-690-080		FUSE, 5A 125V 251<50U, 51U, 54U>	C121	87-010-404-040		CAP, E 4.7-50 SME
FFE801	A8-7ZA-290-030		7ZA-2 FEUNM	C122	87-010-194-080		C-CAP, S 0.047-25 Z F
J252	87-A60-024-010		JACK, DIA#6.3 BLK ST W/SW KM	C123	87-010-196-080		C-CAP, S 0.1-25 Z F C2012
J253	87-099-474-010		JACK, PIN 3P BLK W/SW	C124	87-010-196-080		C-CAP, S 0.1-25 Z F C2012
J254	87-A60-238-010		TERMINAL, SP 4P (MSC)	C125	87-010-196-080		C-CAP, S 0.1-25 Z F C2012
J601	87-A60-330-010		JACK, PIN 6P 3174<50U, 54U, LH>	C127	87-010-196-080		C-CAP, S 0.1-25 Z F C2012
J601	87-A60-426-010		JACK, PIN 6P 3835<51U, HR>	C351	87-012-158-080		C-CAP, S 390P-50 J CH GRM
J801	87-A60-202-010		TERMINAL, ANT 4P MSP-154V-02	C352	87-010-196-080		C-CAP, S 0.1-25 Z F C2012
L201	87-003-383-010		COIL, 1UH K	C353	87-010-196-080		C-CAP, S 0.1-25 Z F C2012
L202	87-003-383-010		COIL, 1UH K	C354	87-010-196-080		C-CAP, S 0.1-25 Z F C2012
L301	87-A50-049-010		COIL, TRAP 85K(COI)	C355	87-010-196-080		C-CAP, S 0.1-25 Z F C2012
L302	87-A50-049-010		COIL, TRAP 85K(COI)	C356	87-010-196-080		C-CAP, S 0.1-25 Z F C2012
L351	87-007-342-010		COIL, OSC 85KHZ BIAS	C357	87-010-196-080		C-CAP, S 0.1-25 Z F C2012
L601	87-003-231-089		C-COIL, 1UH<51U, HR>	C403	87-010-596-080		C-CAP, S 0.047-16 K R
L770	87-005-849-080		COIL, 10UH K CECS	C404	87-010-596-080		C-CAP, S 0.047-16 K R
L771	87-A50-165-010		COIL, FM DET-N(TOK)	C405	87-010-401-040		CAP, E 1-50 M SME
L772	87-A90-245-010		FLTR, CFAZH-450(TOK)<EXP HR>	C406	87-010-401-040		CAP, E 1-50 M SME
L772	87-A90-052-010		FLTR, CFMT-450A (TOK)<HR>	C407	87-010-184-080		C-CAP, S 3300P-50 K B
L832	87-005-847-080		COIL, 2.2UH K CECS	C408	87-010-184-080		C-CAP, S 3300P-50 K B
L941	87-A50-022-010		COIL, ANT SW (COI) 7.96 MHZ<HR>	C409	87-010-593-080		C-CAP, S 0.027-16 K R<50U, 54U>
L942	87-A50-173-010		COIL, OSC SW-N (COI)<HR>	C409	87-010-592-080		C-CAP, S 0.022-16KR<51U, LH, HR>
L943	87-005-372-080		COIL, 1 MHZ K LALO3<HR>	C410	87-010-593-080		C-CAP, S 0.027-16 K R<50U, 54U>
L944	87-A50-159-010		COIL, 10 MH K C28<HR>	C410	87-010-592-080		CAP, S 0.022-16KR<51U, LH, HR>
L981	87-NF4-650-010		COIL, AM PACK4N(TOK)<EXP HR>	C411	87-016-463-080		C-CAP, 0.33-16 K B
L981	87-NF4-666-010		COIL, AM PACK3(TOK)<HR>	C412	87-016-463-080		C-CAP, 0.33-16 K B
PR201	87-026-681-080		PROTECTOR, 5A 491SERIES 60V<LH>	C413	87-010-196-080		C-CAP, S 0.1-25 Z F C2012
PR201	87-026-682-080		PROTECTOR, 10A 491SERIES 60V<HR>	C414	87-010-374-040		CAP, E 47-10 SME
PR202	87-026-681-080		PROTECTOR, 5A 491SERIES 60V<LH>	C415	87-010-374-040		CAP, E 47-10 SME
PR202	87-026-682-080		PROTECTOR, 10A 491SERIES 60V<HR>	C416	87-010-196-080		C-CAP, S 0.1-25 Z F C2012
R123	87-022-200-080		RES, M/F 0.56-1W J<50U, 51U, 54U>	C417	87-016-081-080		C-CAP, S 0.1-16 K R
R229	87-A00-257-080		RES, M/F 0.15-1W J<50U, 51U, 54U>	C418	87-010-405-040		CAP, E 10-50 M SME
R230	87-A00-257-080		RES, M/F 0.15-1W J<50U, 51U, 54U>	C501	87-010-319-080		C-CAP, S 56P-50J CH<EXP 50U, 54U>
R231	87-A00-262-080		RES, M/F 0.15-2W J<LH, HR>	C502	87-010-319-080		C-CAP, S 56P-50J CH<EXP 50U, 54U>
R232	87-A00-262-080		RES, M/F 0.15-2W J<LH, HR>	C503	87-012-393-080		C-CAP, S 0.22-16KW5<EXP 50U, 54U>
RY101	87-045-389-010		RELAY, 12V OSA-SS-212DM5	C504	87-010-197-080		C-CAP, S 0.01-25K B<EXP 50U, 54U>
RY201	87-045-382-010		RELAY, 12V OUAZ-SH<LH, HR, 51U>	C505	87-010-180-080		C-CAP, S 1500P-50KB<EXP 50U, 54U>
SFR301	87-024-438-080		SFR, 220K H RH063MC	C506	87-010-213-080		C-CAP, S 0.015-25KB<EXP 50U, 54U>
SFR302	87-024-438-080		SFR, 220K H RH063MC	C507	87-010-213-080		C-CAP, S 0.015-25KB<EXP 50U, 54U>
SFR303	87-024-438-080		SFR, 220K H RH063MC	C508	87-010-197-080		C-CAP, S 0.01-25KB<EXP 50U, 54U>
SFR304	87-024-438-080		SFR, 220K H RH063MC	C509	87-010-181-080		C-CAP, S 1800P-50KB<EXP 50U, 54U>
SFR351	87-024-436-080		SFR, 47K H RH063MC	C510	87-010-196-080		C-CAP, S 0.1-25 Z F<EXP 50U, 54U>
SFR352	87-024-436-080		SFR, 47K H RH063MC	C511	87-010-196-080		C-CAP, S 0.1-25 Z F<EXP 50U, 54U>
TH201	87-A90-221-080		C-THMS 100K<HR>	C512	87-010-374-040		CAP, E 47-10 SME<EXP 50U, 54U>
TH202	87-A90-221-080		C-THMS 100K<HR>	C513	87-010-494-040		CAP, E 1-50 5L SRE<EXP 50U, 54U>
W001	85-NF5-628-010		F-CABLE, 7P-2.5	C514	87-010-494-040		CAP, E 1-50 5L SRE<EXP 50U, 54U>
X721	87-A70-061-010		VIB, XTAL 4.500MHZ CSA-309	C515	87-010-183-080		C-CAP, S 2700P-50KB<EXP 50U, 54U>
X771	87-030-354-01		VIB, CER 450.0KHZ BFUC<HR>	C516	87-010-183-080		C-CAP, S 2700P-50KB<EXP 50U, 54U>
				C518	87-010-196-080		C-CAP, S 0.1-25 Z F<EXP 50U, 54U>
				C519	87-015-677-040		CAP, E 100-6.3 M 7L<EXP 50U, 54U>
				C523	87-012-141-080		CAP, S 0.22-16 Z F<EXP 50U, 54U>
FRONT C.B							
C101	87-010-198-080		C-CAP, S 0.022-25 K B	C601	87-010-560-040		CAP, E 10-50 M 5L MA
C102	87-010-198-080		C-CAP, S 0.022-25 K B	C602	87-010-186-080		C-CAP, S 4700P-50KB<EXP 50U, 54U>
C103	87-010-197-080		C-CAP, S 0.01-25 K B	C603	87-010-498-040		CAP, E 10-16 M 5L<EXP 50U, 54U>
C104	87-010-312-080		C-CAP, S 15P-50 J CH	C604	87-010-499-040		CAP, E 22-6.3 M 5L<EXP 50U, 54U>
C105	87-010-316-080		C-CAP, S 33P-50 J CH	C605	87-010-196-080		C-CAP, S 0.1-25 Z F C2012
C106	87-010-320-080		C-CAP, S 68P-50 J CH	C607	87-010-321-080		C-CAP, S 82P-50 J CH
C107	87-012-157-080		C-CAP, S 330P-50 J CH GRM	C608	87-010-196-080		C-CAP, S 0.1-25 Z F C2012
C108	87-010-405-040		CAP, E 10-50 M SME	C609	87-010-491-040		CAP, E 0.22-50 5L SRE
C109	87-010-494-040		CAP, E 1-50 5L SRE	C611	87-010-177-080		C-CAP, S 820P-50 J SL
C110	87-010-196-080		C-CAP, S 0.1-25 Z F C2012	C614	87-010-248-040		CAP, E 220-10 M SME
C111	87-010-196-080		C-CAP, S 0.1-25 Z F C2012	FB601	87-008-372-080		FLTR, EMIBL01 RN1
C112	87-010-196-080		C-CAP, S 0.1-25 Z F C2012	FL101	87-NF6-610-010		FL, BJ531GK
C113	87-A10-189-040		CAP, E 220-10 M	J601	87-A60-284-010		JACK, 3.5MO (MSC)
C114	87-010-196-080		C-CAP, S 0.1-25 Z F C2012	J602	87-A60-284-010		JACK, 3.5MO (MSC)<EXP 50U, 54U>
C115	87-010-178-080		C-CAP, S 1000P-50 K B	L501	87-005-448-080		COIL, 220UH K FLR50<EXP 50U, 54U>

REF. NO.	PART NO.	KANRI NO.	DESCRIPTION	REF. NO.	PART NO.	KANRI NO.	DESCRIPTION
LED201	87-A40-317-080		LED, SLR-342VCT31 RED	S313	87-A90-095-080		SW, TACT EVQ11G04M
LED202	87-A40-317-080		LED, SLR-342VCT31 RED				
LED203	87-A40-317-080		LED, SLR-342VCT31 RED				
LED204	87-A40-317-080		LED, SLR-342VCT31 RED				
LED205	87-A40-317-080		LED, SLR-342VCT31 RED				
				AC1 C.B			
LED206	87-A40-316-080		LED, SLR-56PCT31 GRN	△ FC001	87-033-147-010		FUSE CLAMP, MT-20<LH, HR>
LED207	87-A40-316-080		LED, SLR-56PCT31 GRN	△ FC1	87-033-213-080		FUSE CLAMP, PFC5000<50U, 51U, 54U>
LED208	87-A40-316-080		LED, SLR-56PCT31 GRN	△ FC002	87-033-147-010		FUSE CLAMP, MT-20<LH, HR>
LED209	87-A40-316-080		LED, SLR-56PCT31 GRN	△ FC2	87-033-213-080		FUSE CLAMP, PFC5000<50U, 51U, 54U>
LED210	87-A40-316-080		LED, SLR-56PCT31 GRN	△ F101	87-056-691-080		FUSE, 10A 125V 251<50U, 51U, 54U>
				△ F101	87-035-369-010		FUSE, 5 A 250V T<LH, HR>
LED211	87-A40-316-080		LED, SLR-56PCT31 GRN	△ PT101	87-NF6-621-010		PT, 7NF-6 U<50U, 51U, 54U>
LED212	87-A40-316-080		LED, SLR-56PCT31 GRN	△ PT101	87-NF6-623-010		PT, 7NF-6 HR<HR>
LED213	87-A40-316-080		LED, SLR-56PCT31 GRN	△ PT101	87-NF6-625-010		PT, 7NF-6 LH<LH>
LED214	87-A40-316-080		LED, SLR-56PCT31 GRN	△ SW001	87-A90-165-010		SW, SL 1-2-3 SWS2301<LH, HR>
LED215	87-A40-316-080		LED, SLR-56PCT31 GRN				
LED216	87-A40-264-080		LED, SLH-56PCTE7 GRN	△ T1	87-A60-317-010		TERMINAL, 1P MSC<50U, 51U, 54U>
LED217	87-A40-264-080		LED, SLH-56PCTE7 GRN	△ T001	87-A60-317-010		TERMINAL, 1P MSC<LH, HR>
LED218	87-A40-264-080		LED, SLH-56PCTE7 GRN	△ T002	87-A60-317-010		TERMINAL, 1P MSC<LH, HR>
LED219	87-A40-264-080		LED, SLH-56PCTE7 GRN	△ T2	87-A60-317-010		TERMINAL, 1P MSC<50U, 51U, 54U>
LED220	87-A40-264-080		LED, SLH-56PCTE7 GRN				
				AC2 C.B			
LED221	87-A40-264-080		LED, SLH-56PCTE7 GRN	△ F001	87-026-691-080		FUSE, 10A 125V 251<50U, 51U, 54U>
LED233	87-A40-265-010		LED, SLH-56PCL GRN	△ F002	87-026-691-080		FUSE, 10A 125V 251<50U, 51U, 54U>
LED234	87-A40-265-010		LED, SLH-56PCL GRN	△ F005	87-026-691-080		FUSE, 10A 125V 251<50U, 51U, 54U>
LED235	87-A40-267-010		LED, SLH-56VCL RED	△ F006	87-026-691-080		FUSE, 10A 125V 251<50U, 51U, 54U>
LED236	87-A40-267-010		LED, SLH-56VCL RED	△ PR001	87-026-682-080		PROTECTOR, 10A 491 SERIES<LH, HR>
LED237	87-A40-265-010		LED, SLH-56PCL GRN				
LED238	87-A40-265-010		LED, SLH-56PCL GRN	△ PR002	87-026-682-080		PROTECTOR, 10A 491SERIES<LH, HR>
S302	87-A90-164-080		SW, TACT SKQNAB(N)	△ PR005	87-026-682-080		PROTECTOR, 10A 491SERIES<LH, HR>
S303	87-A90-164-080		SW, TACT SKQNAB(N)	△ PR006	87-026-682-080		PROTECTOR, 10A 491SERIES<LH, HR>
S304	87-A90-164-080		SW, TACT SKQNAB(N)				
S305	87-A90-164-080		SW, TACT SKQNAB(N)	DECK C.B			
S306	87-A90-164-080		SW, TACT SKQNAB(N)				
S307	87-A90-164-080		SW, TACT SKQNAB(N)	CON502	87-099-756-010		CONN, 15P 9604 S F
S308	87-A90-164-080		SW, TACT SKQNAB(N)	SFR1	87-024-581-089		SFR, 3.3K DIA 6H
S314	87-A90-164-080		SW, TACT SKQNAB(N)	SOL1	82-ZM1-618-010		SOL ASSY, 27
				SOL2	82-ZM1-618-010		SOL ASSY, 27
S315	87-A90-164-080		SW, TACT SKQNAB(N)	SW1	87-A90-248-010		SW, MICRO ESE11SH2CXQ
S316	87-A90-164-080		SW, TACT SKQNAB(N)				
S317	87-A90-164-080		SW, TACT SKQNAB(N)	SW2	87-A90-248-010		SW, MICRO ESE11SH2CXQ
S318	87-A90-164-080		SW, TACT SKQNAB(N)	SW3	87-A90-248-010		SW, MICRO ESE11SH2CXQ
S319	87-A90-164-080		SW, TACT SKQNAB(N)	SW4	87-036-110-010		SW, MICRO SPPB62
				SW5	87-036-110-010		SW, MICRO SPPB62
S320	87-A90-164-080		SW, TACT SKQNAB(N)	SW6	87-036-110-010		SW, MICRO SPPB62
S323	87-A90-164-080		SW, TACT SKQNAB(N)				
S324	87-A90-164-080		SW, TACT SKQNAB(N)	SW8	87-A90-248-010		SW, MICRO ESE11SH2CXQ
S325	87-A90-164-080		SW, TACT SKQNAB(N)	SW9	87-036-110-010		SW, MICRO SPPB62
S326	87-A90-164-080		SW, TACT SKQNAB(N) <EXP 50U, 54U>	W1	82-ZM3-601-019		RBN, CORD 4P-75
S327	87-A90-164-080		SW, TACT SKQNAB(N) <EXP 50U, 54U>				
S328	87-A90-164-080		SW, TACT SKQNAB(N)	HEAD-1 C.B			
S331	87-A90-164-080		SW, TACT SKQNAB(N)				
S332	87-A90-164-080		SW, TACT SKQNAB(N)				
S333	87-A90-164-080		SW, TACT SKQNAB(N) <EXP 50U, 54U>	85-ZM3-602-010			PWB, FLEX A
S334	87-A90-164-080		SW, TACT SKQNAB(N) <EXP 50U, 54U>				
S335	87-A90-164-080		SW, TACT SKQNAB(N) <EXP 50U, 54U>	HEAD-2 C.B			
S337	87-A90-164-080		SW, TACT SKQNAB(N)				
S342	87-A90-164-080		SW, TACT SKQNAB(N)				
S365	87-A90-164-080		SW, TACT SKQNAB(N)	85-ZM3-602-010			PWB, FLEX A
S366	87-A90-164-080		SW, TACT SKQNAB(N)				
S367	87-A90-164-080		SW, TACT SKQNAB(N)				
S368	87-A90-164-080		SW, TACT SKQNAB(N)				
S369	87-A90-164-080		SW, TACT SKQNAB(N)				
SW101	87-A90-392-010		SW, RTRY EC16B24304-20<50U, 54U>				
SW101	87-A90-535-010		SW, RTRY EC16B24304<EXP 50U, 54U>				
VR601	86-NFA-607-010		VR, RTRY 10K15AX1<50U, 54U>				
X101	87-A70-070-080		VIB, CER 5.76MHZ CRHF				
				KEY C.B			
S309	87-A90-095-080		SW, TACT EVQ11G04M				
S310	87-A90-095-080		SW, TACT EVQ11G04M				
S311	87-A90-095-080		SW, TACT EVQ11G04M				
S312	87-A90-095-080		SW, TACT EVQ11G04M				

○ チップ抵抗部品コード / CHIP RESISTOR PART CODE

チップ抵抗部品コードの成り立ち
Chip Resistor Part Coding

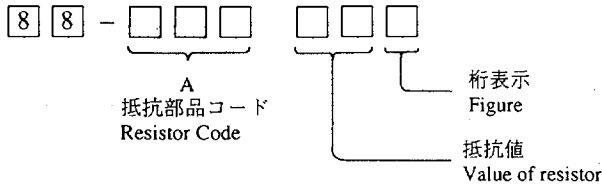

チップ抵抗
Chip resistor

容量 Wattage	種類 Type	許容誤差 Tolerance	記号 Symbol	寸法 / Dimensions (mm)			抵抗コード : A Resistor Code: A	
				外形 / Form	L	W		t
1/16W	1608	±5%	CJ		1.6	0.8	0.45	108
1/10W	2125	±5%	CJ		2	1.25	0.45	118
1/8W	3216	±5%	CJ		3.2	1.6	0.55	128

TRANSISTOR ILLUSTRATION



E C B

KTA1266GR
KTC3198GR



E C B

CSD1489B
CSB1058B



E C B

2SA933S



G D S

2SK2723



B C E

2SB1370
FN1016
FP1016

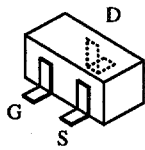

2SK2158

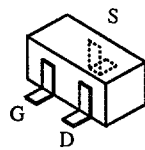

2SK543

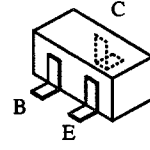

2SC2714
RN1410
2SC3052F
2SA1235F
RT1N141C
2SC3052

CSA1362GR
RT1N144C
CSD1306E
CMBT5551
RT1P144C
RT1P141C



E B C

C2N5401

BLOCK DIAGRAM

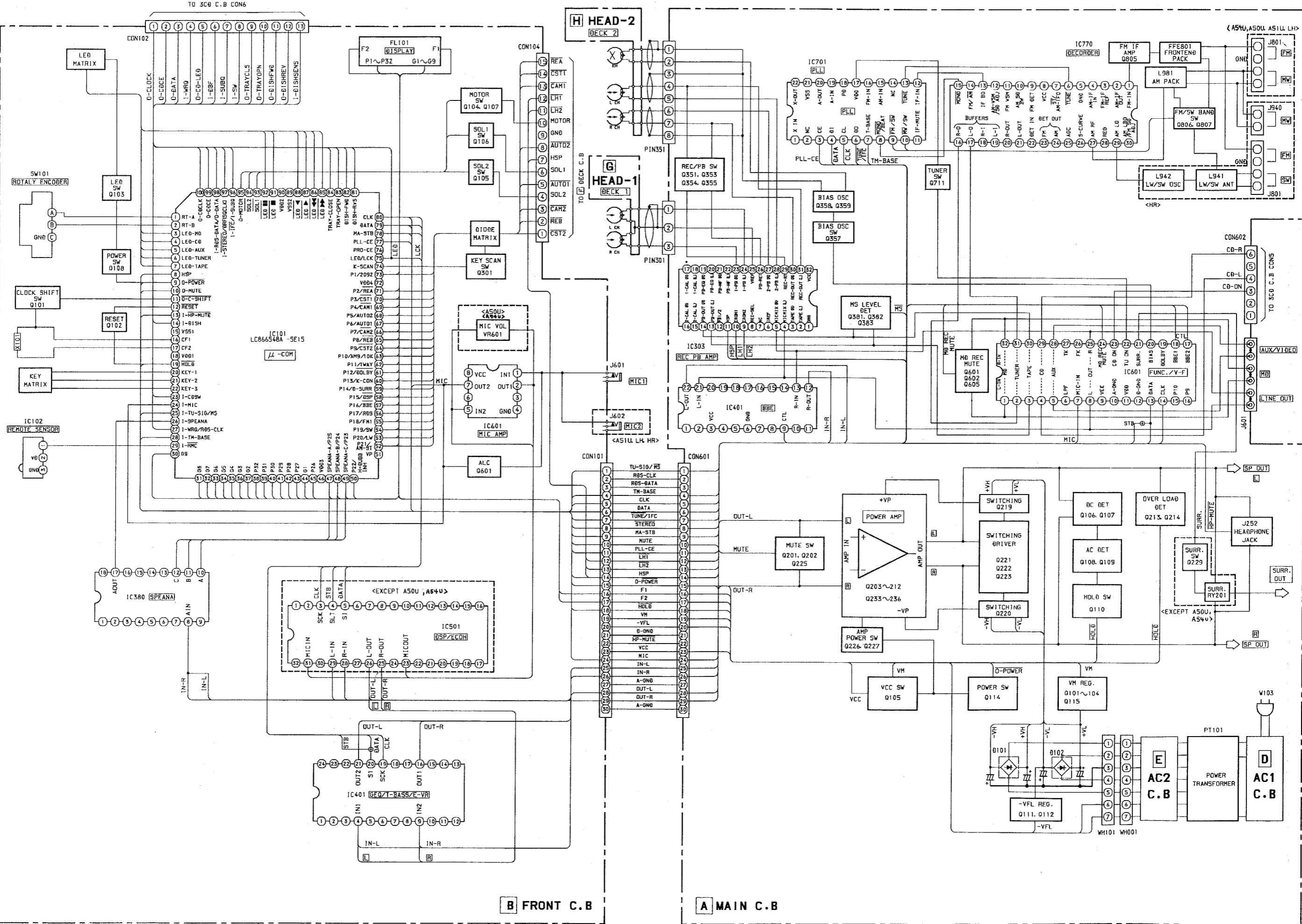

1 2 3 4 5 6 7 8 9 10 11 12 13 14

A
B
C
D
E
F
G
H
I
J

A MAIN C.B

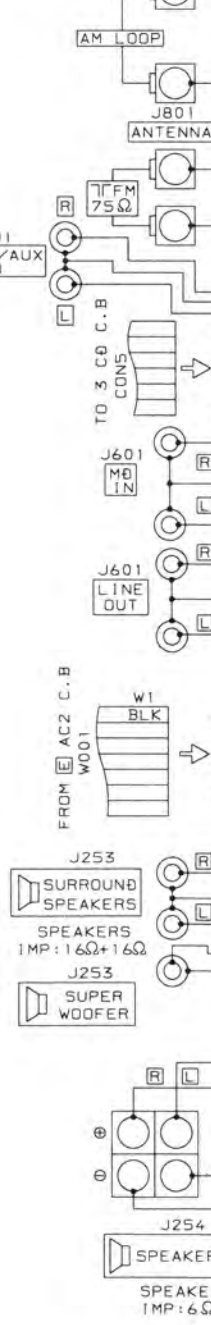
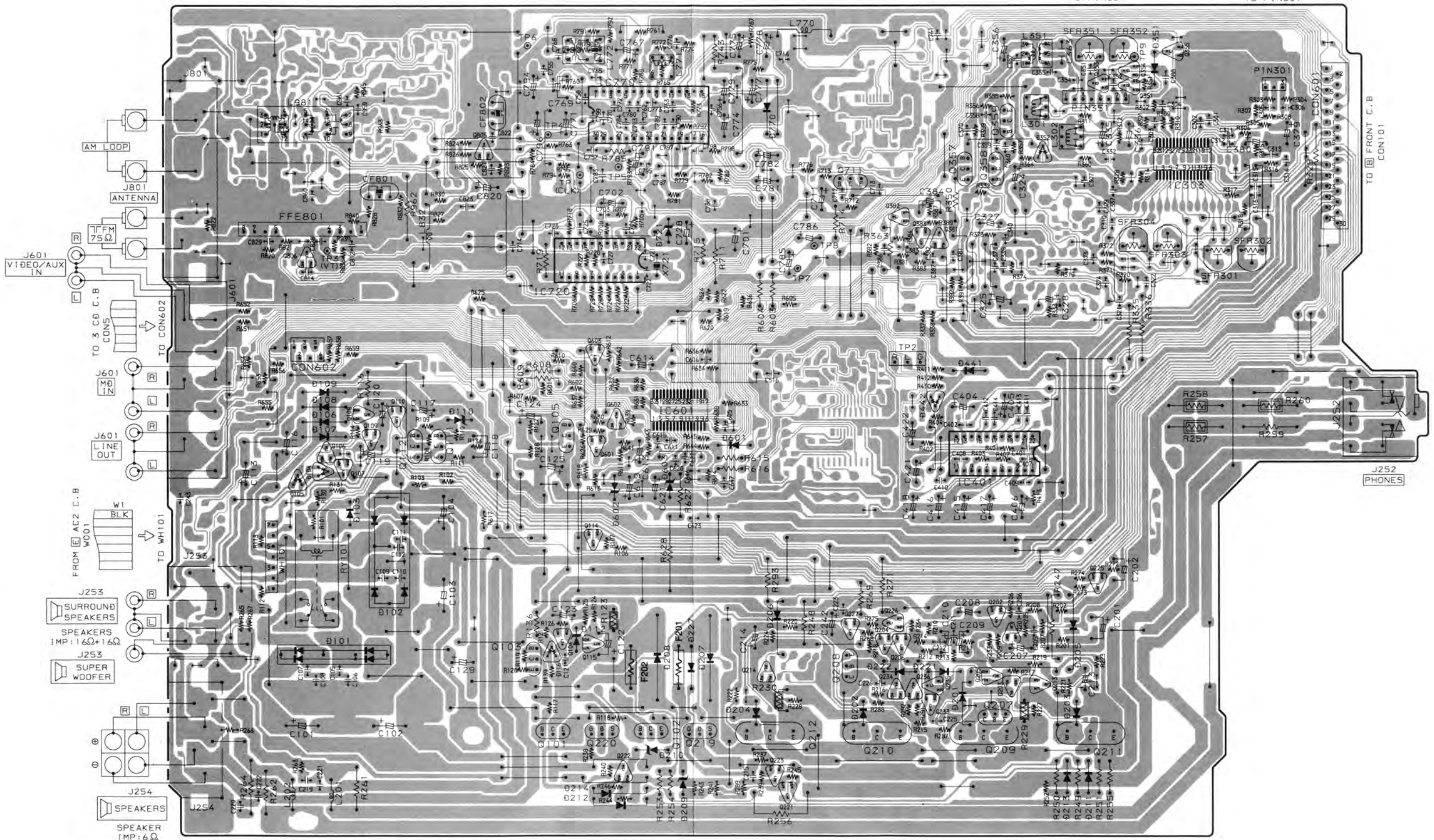

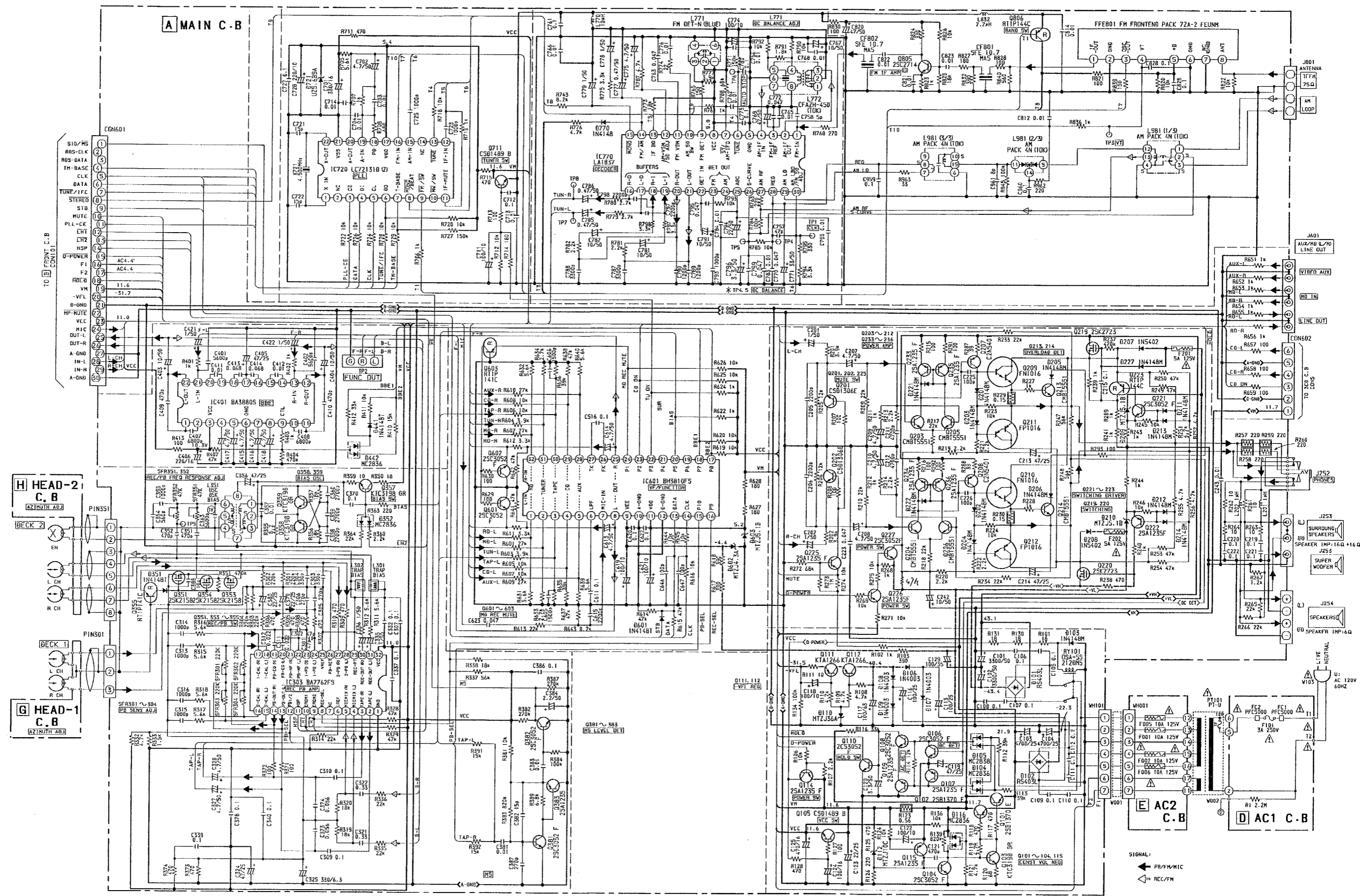

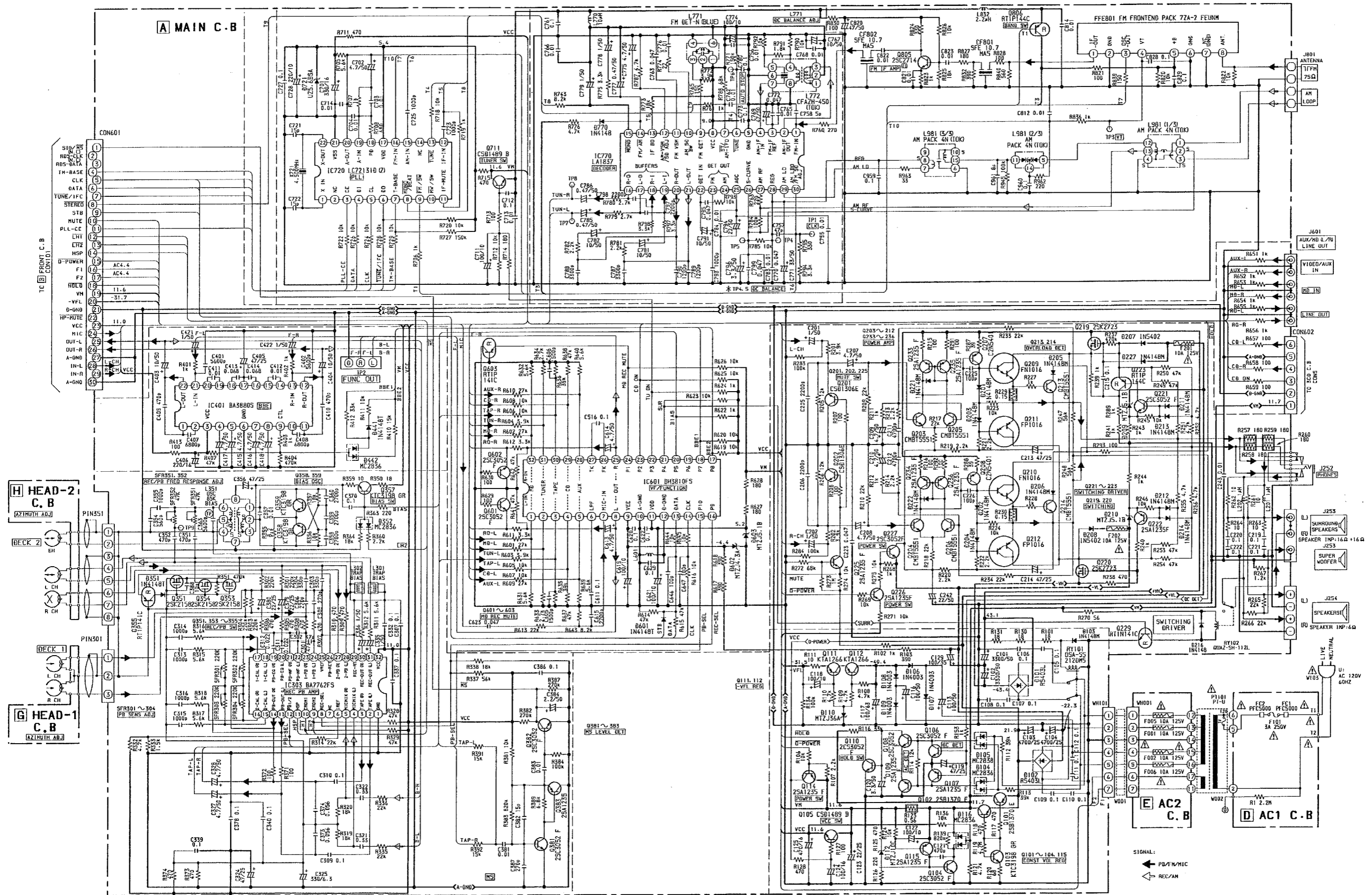

1 2 3 4 5 6 7 8 9 10 11 12 13 14

A
B
C
D
E
F
G
H
I
J

A MAIN C.B

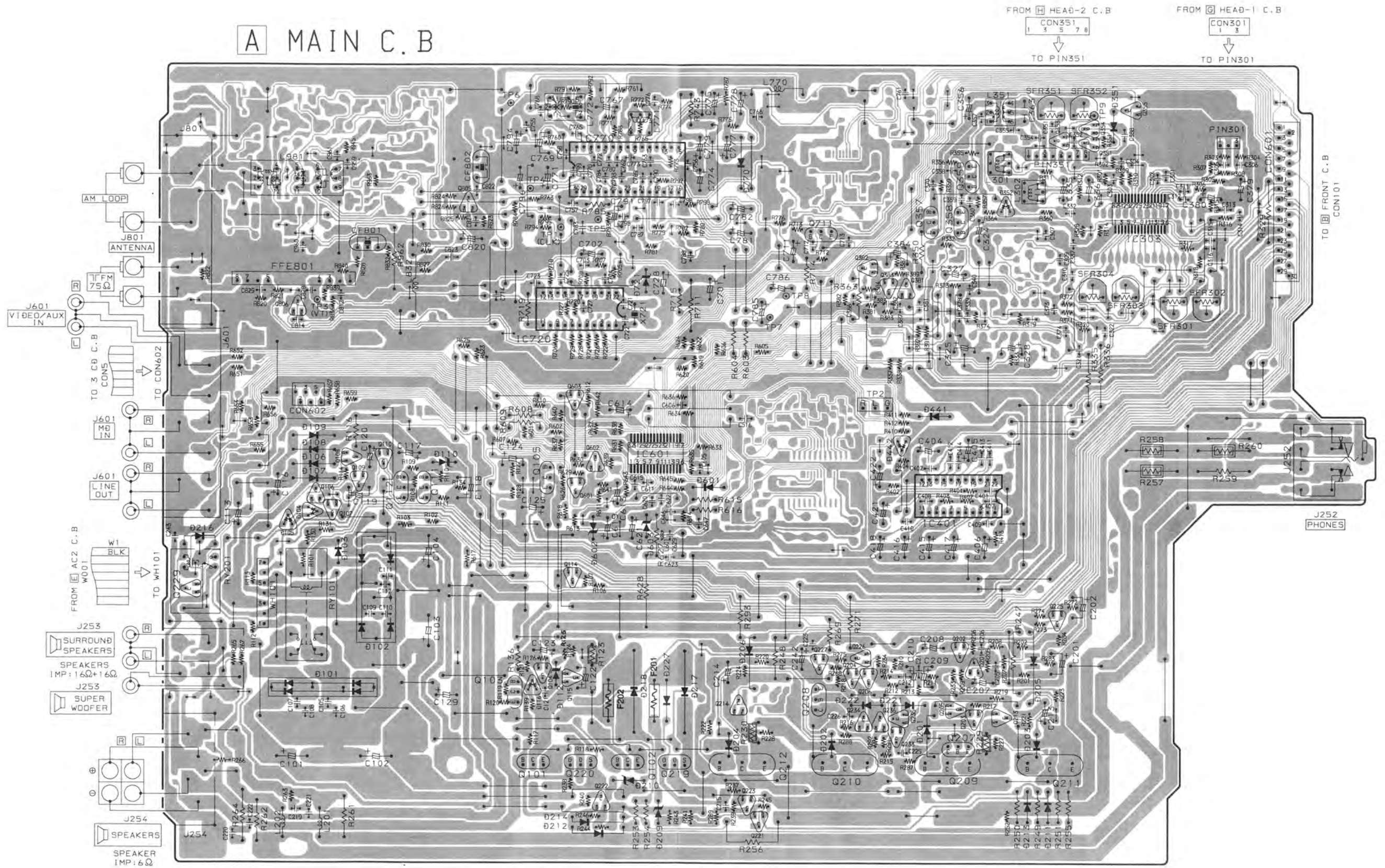

1 2 3 4 5 6 7 8 9 10 11 12 13 14

A
B
C
D
E
F
G
H
I
J

A MAIN C.B

FROM HEAD-2 C.B
CON351
1 3 5 7 8
TO PIN351

FROM HEAD-1 C.B
CON301
1 3
TO PIN301

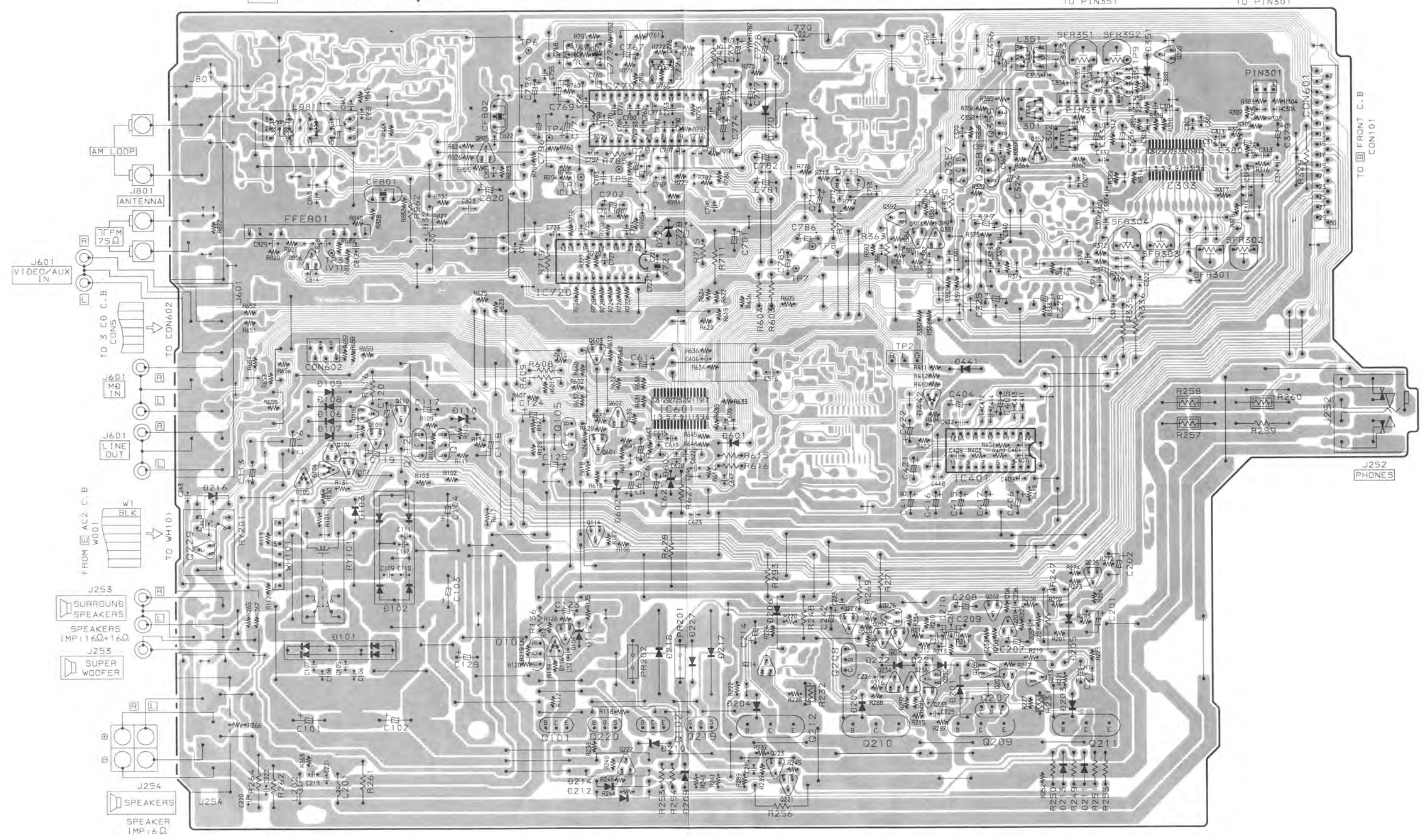

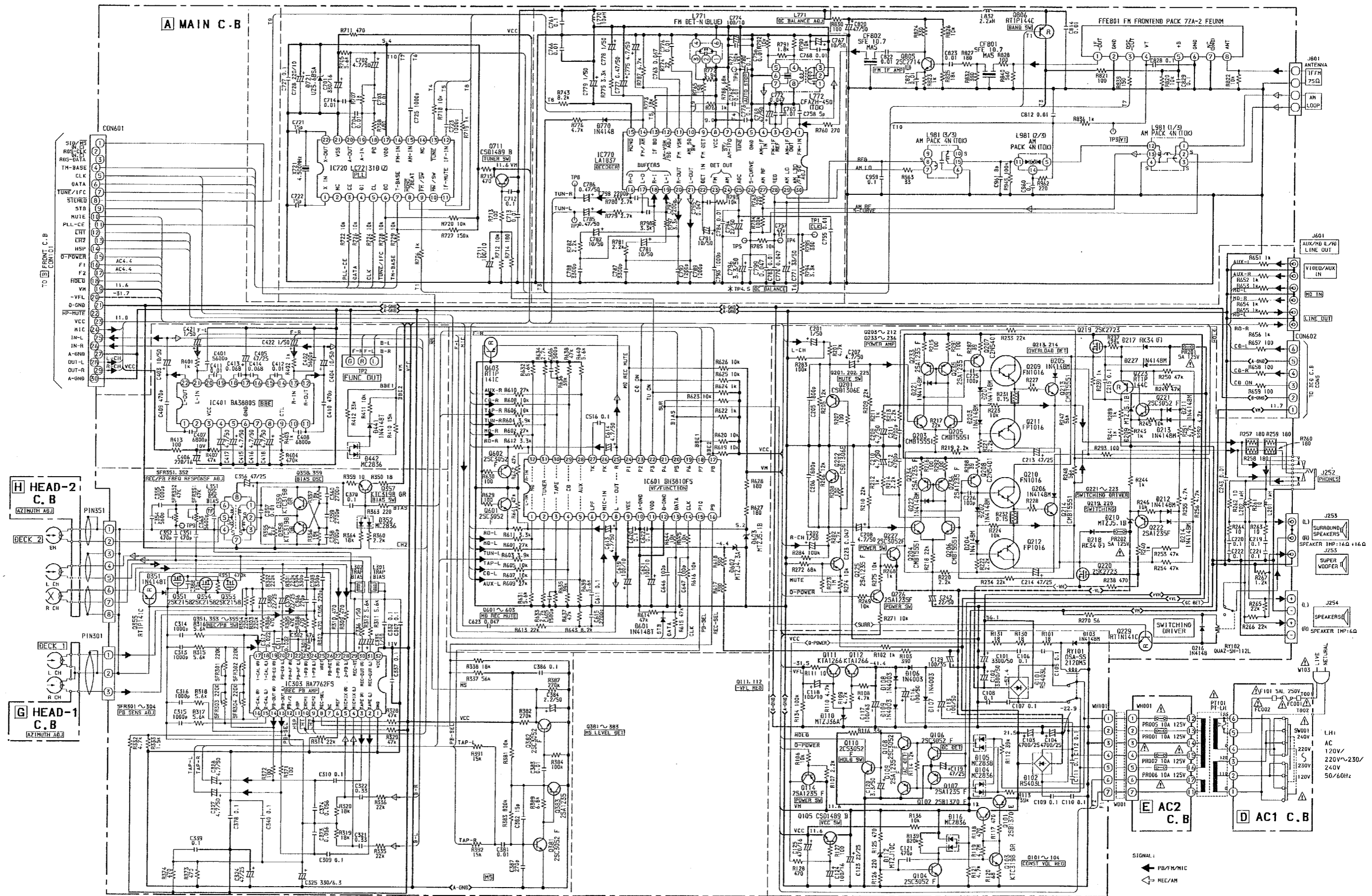

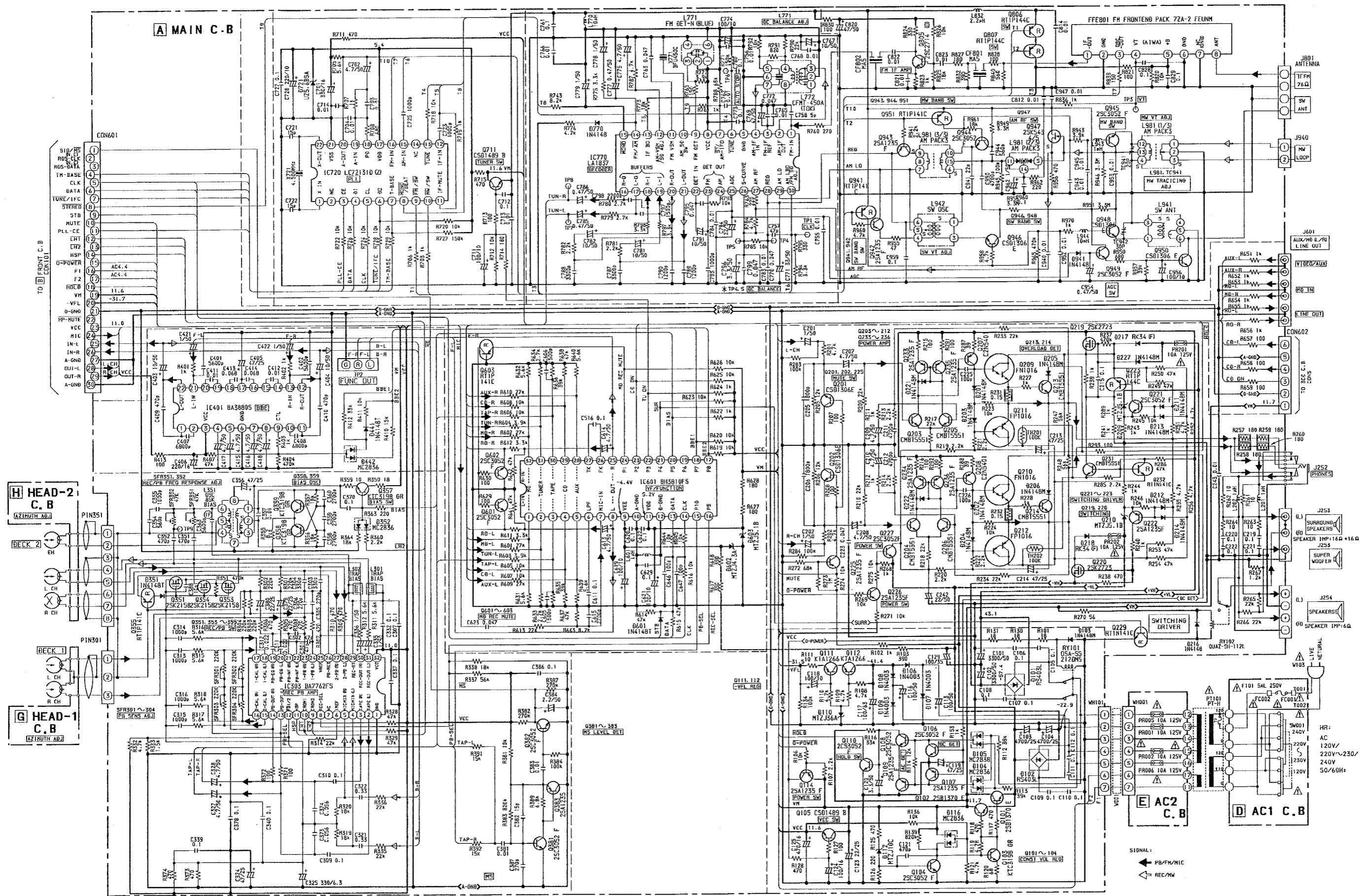

A MAIN C.B

FROM HEAD-2 C.B
CON351
TO PIN351
FROM HEAD-1 C.B
CON301
TO PIN301

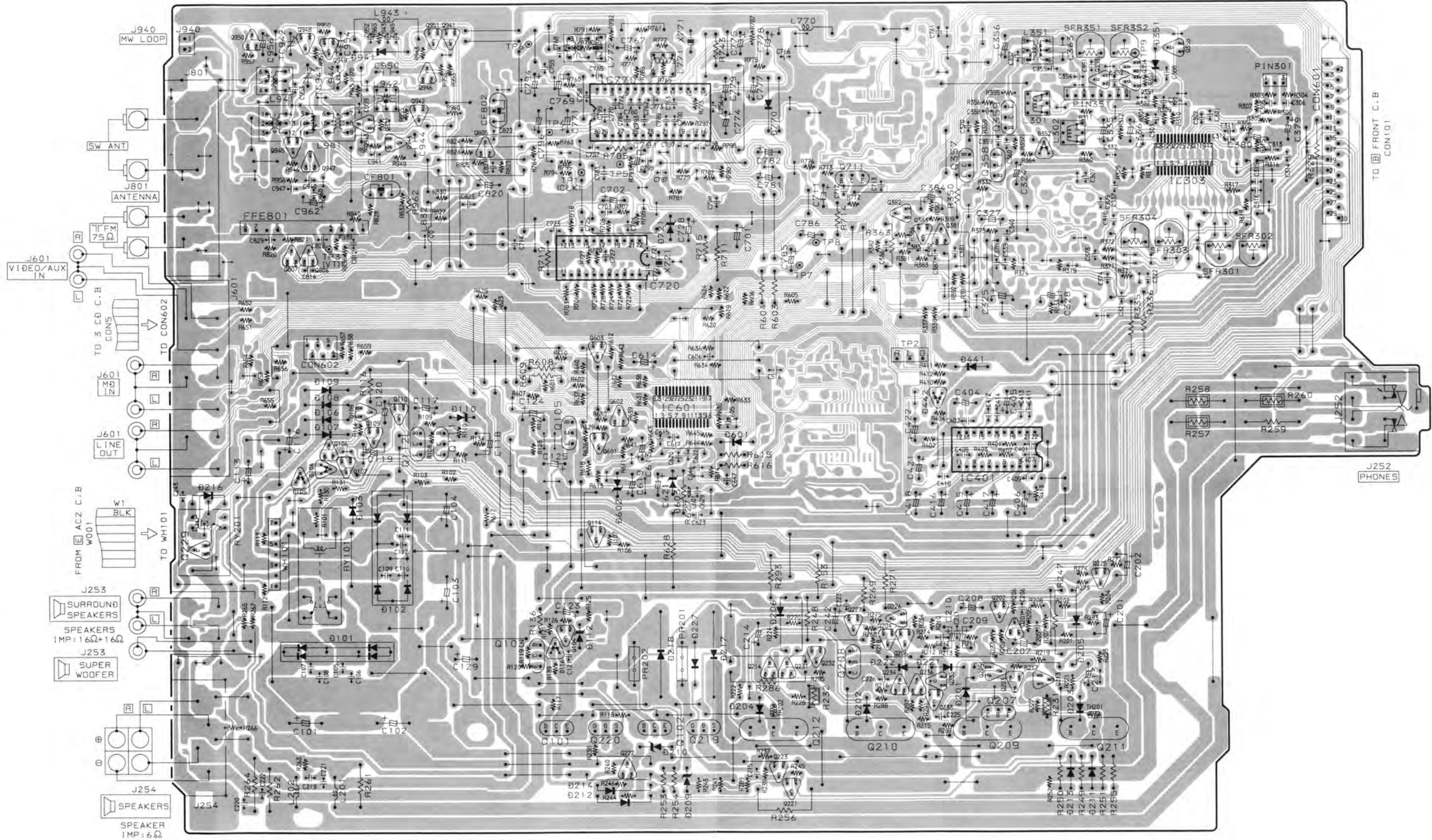

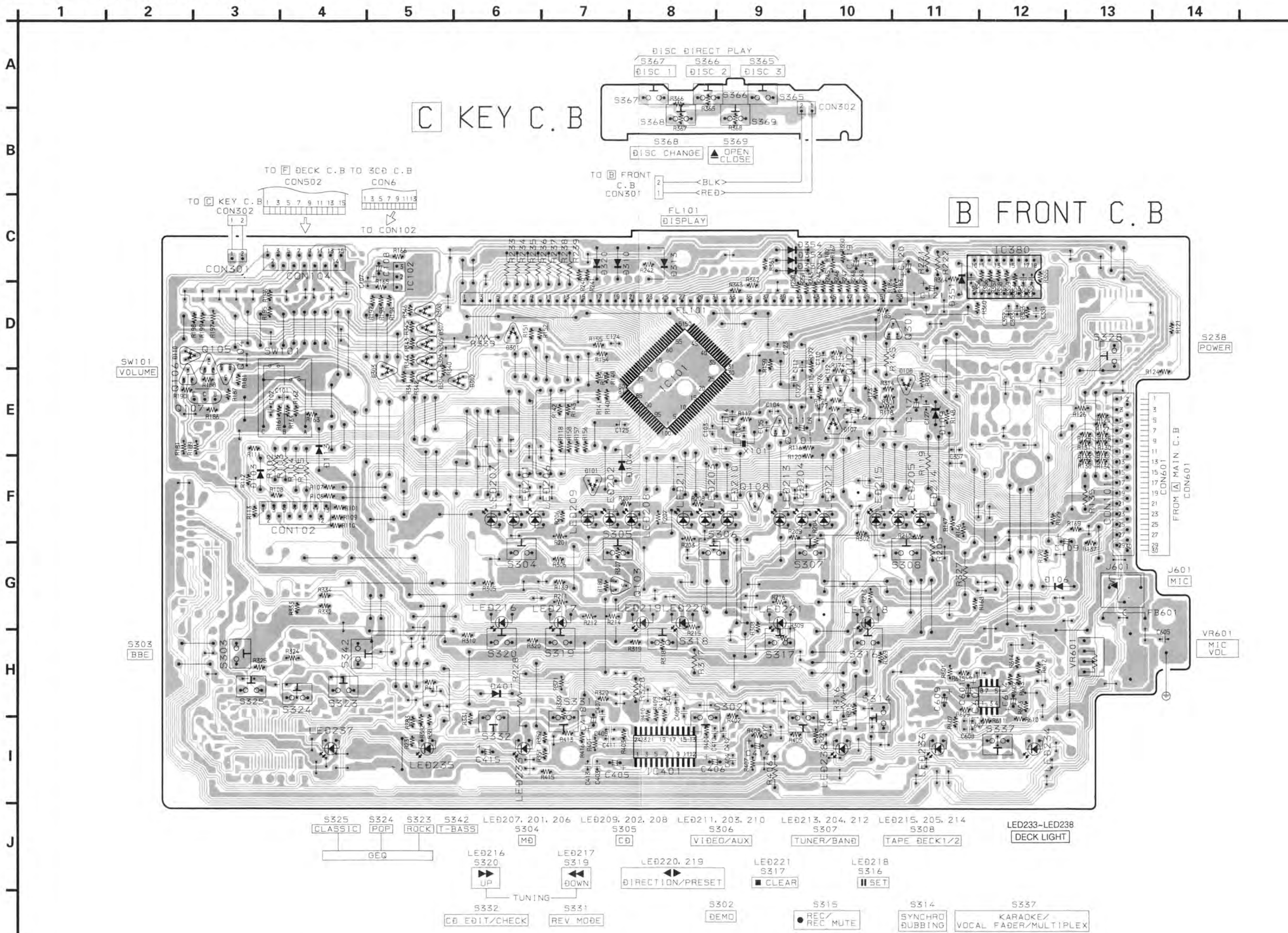

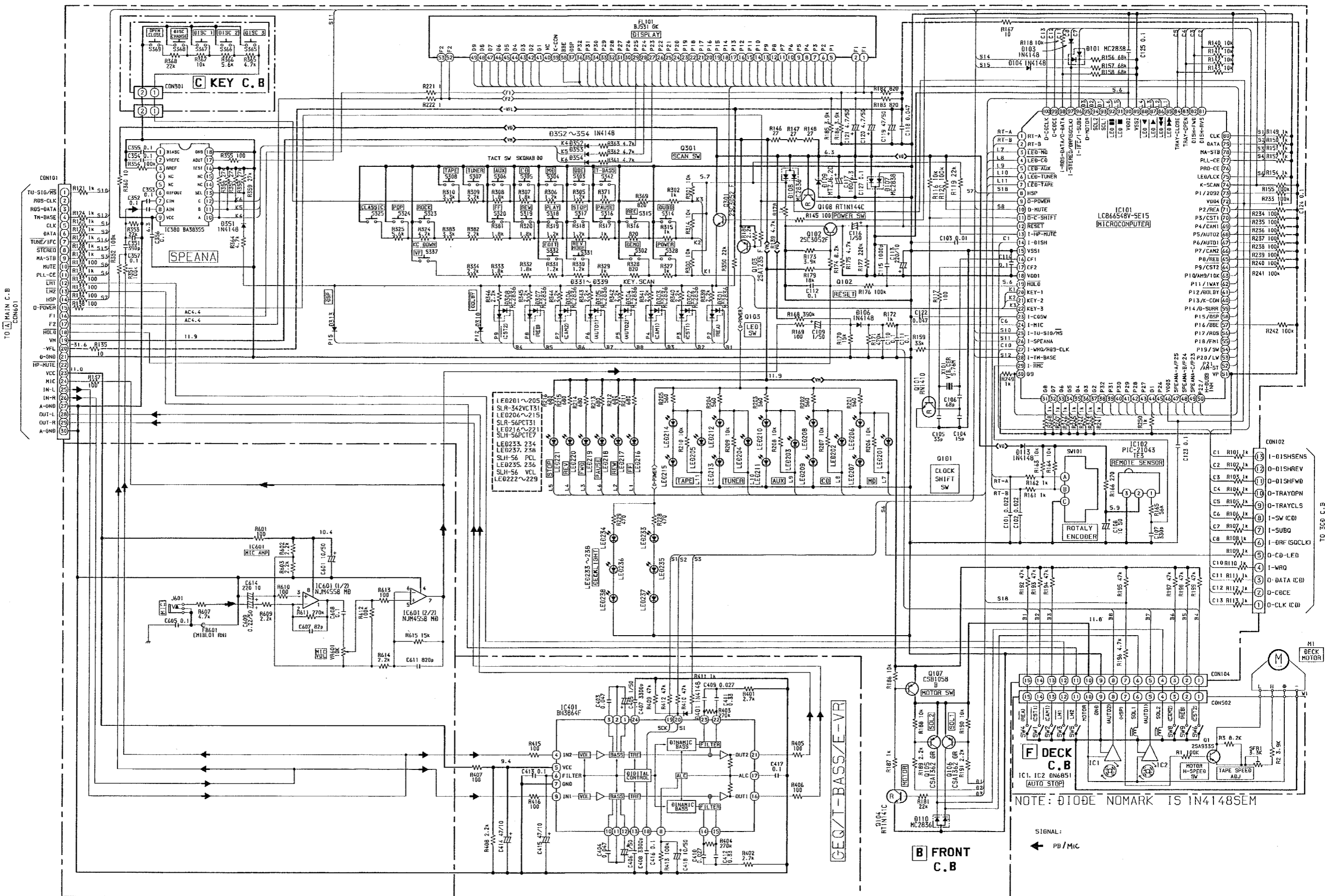

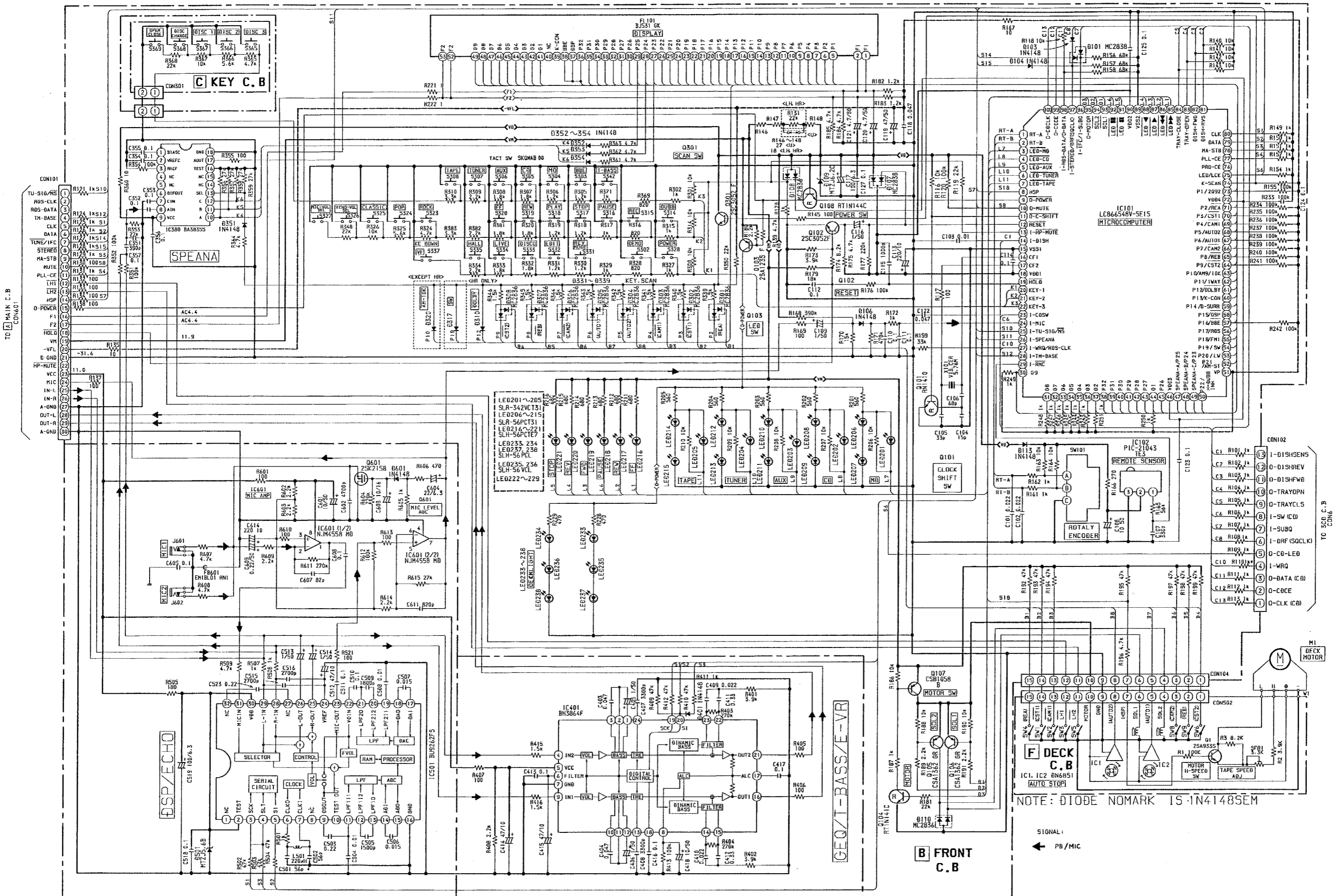

1 2 3 4 5 6 7 8 9 10 11 12 13 14

A
B
C
D
E
F
G
H
I
J

C KEY C.B

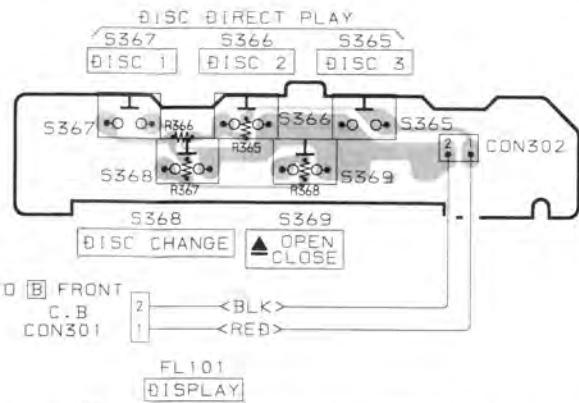

B FRONT C.B

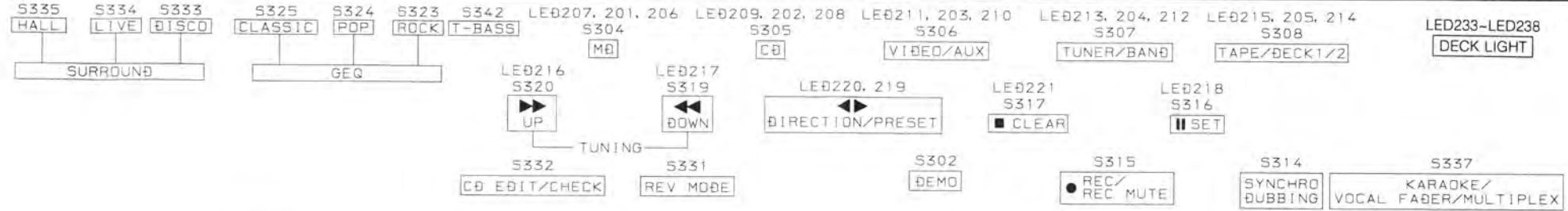
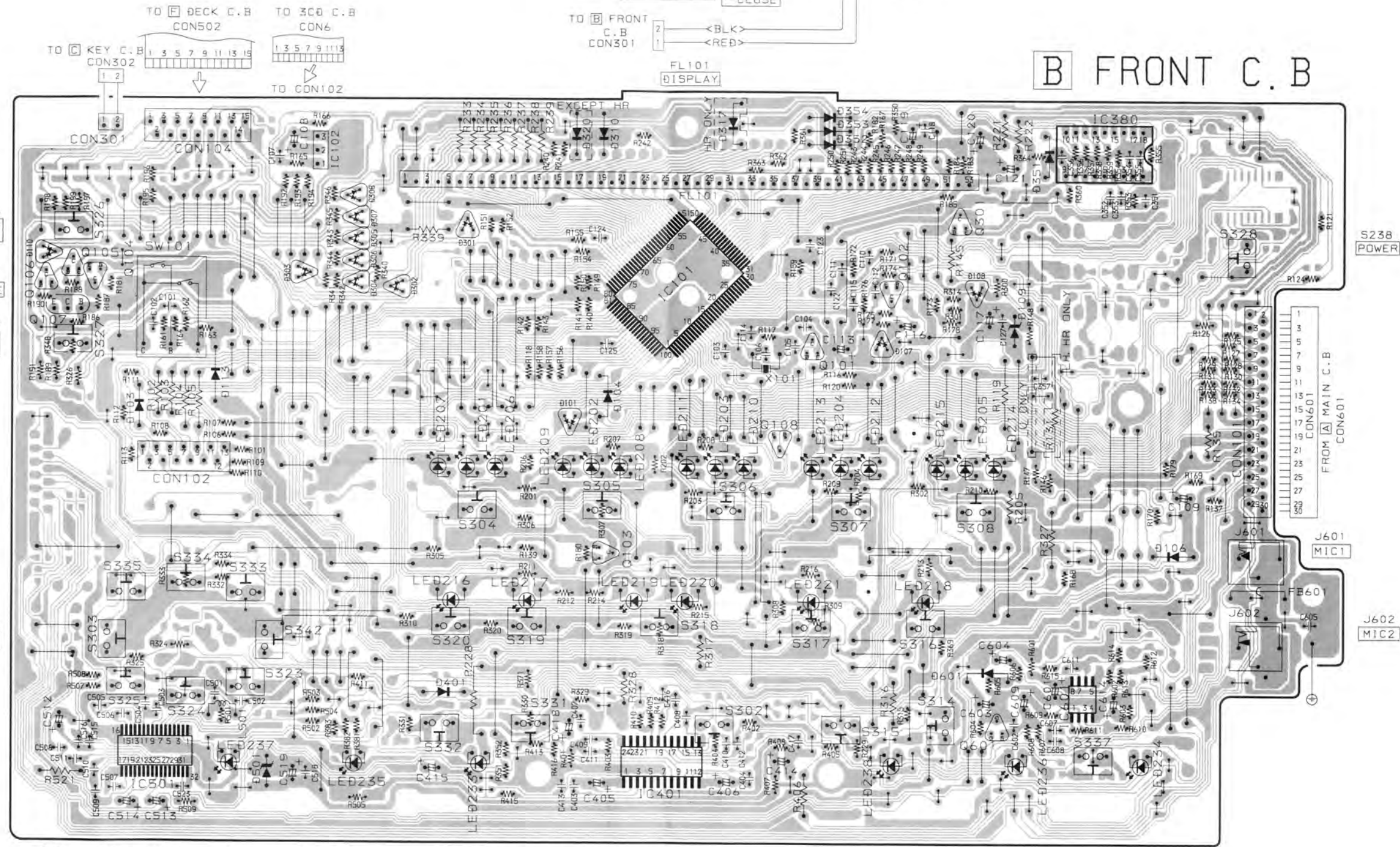

SCHEMATIC DIAGRAM - 7 (TUNER FRONT END)

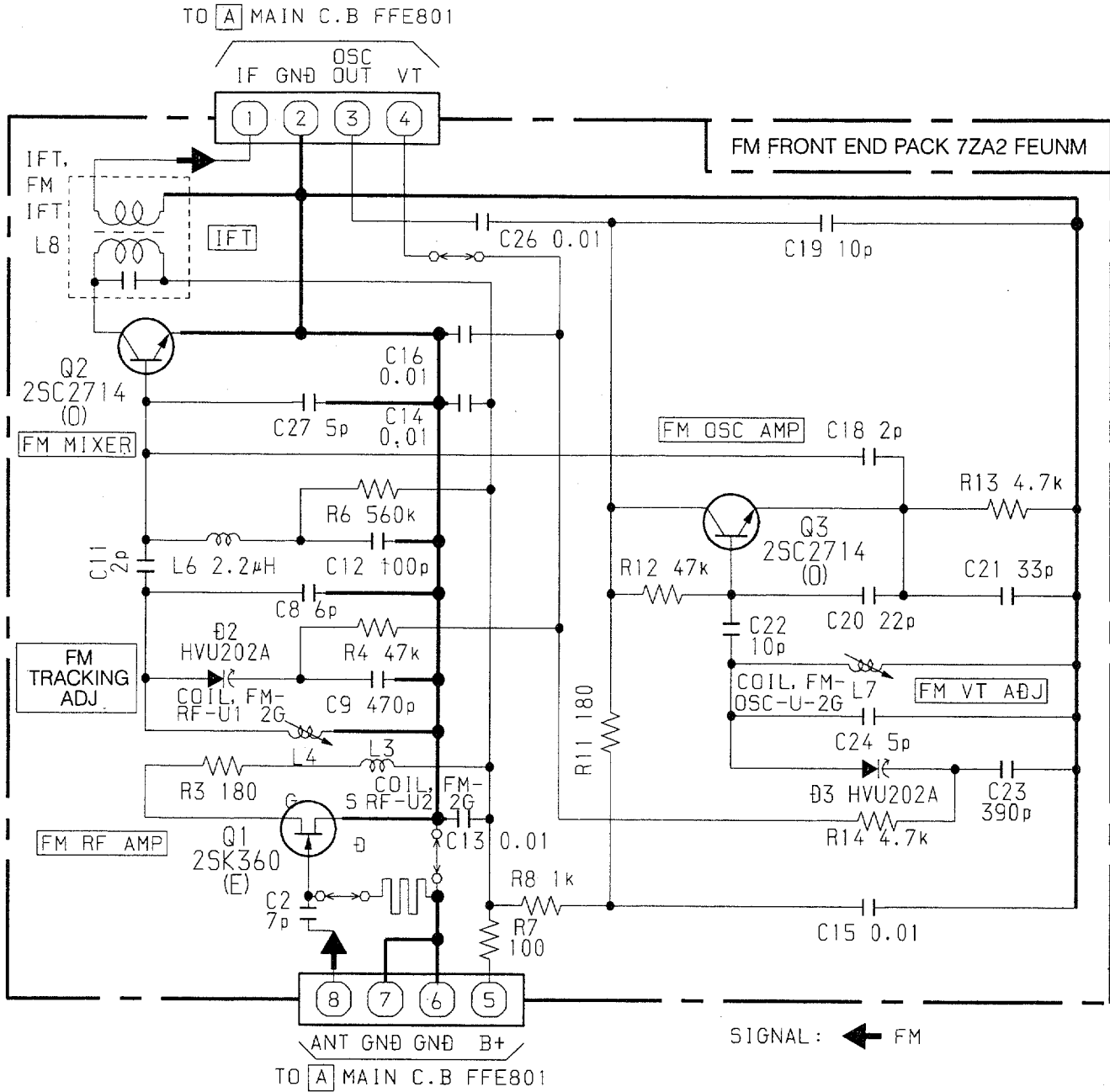

WIRING - 7 (AC)

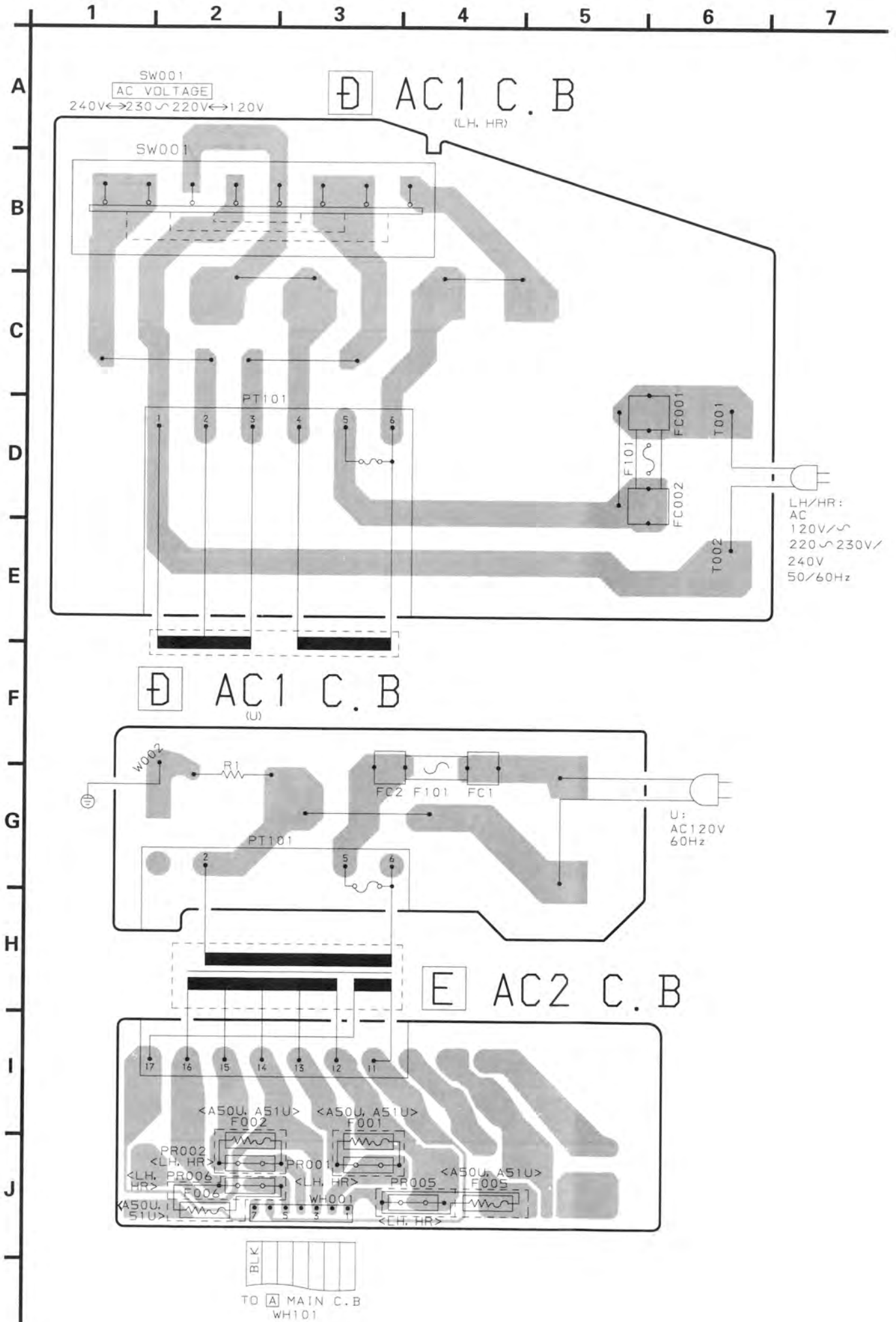

WIRING - 8 (DECK)

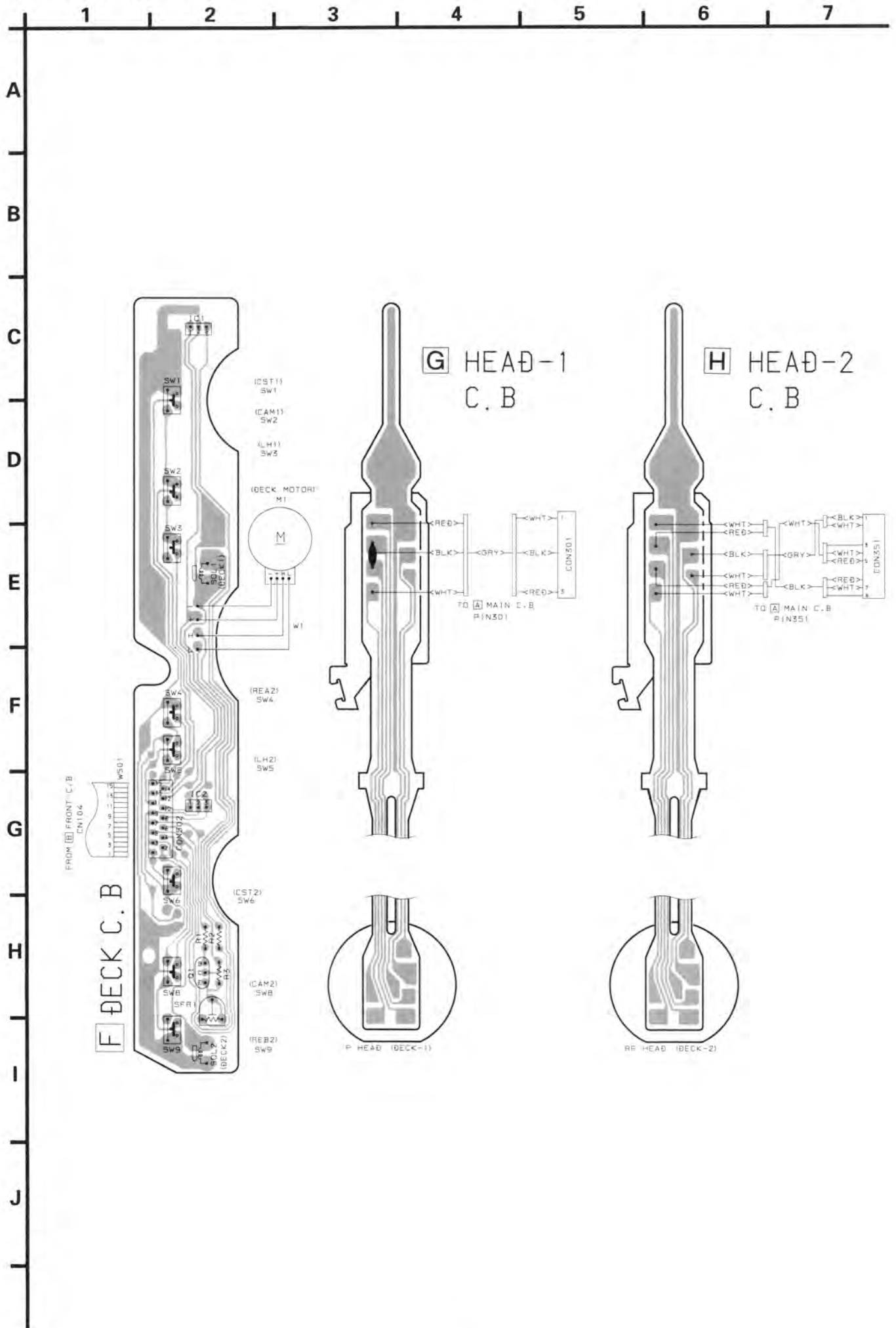

FL GRID ASSIGNMENT

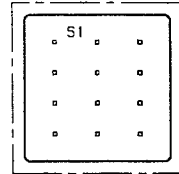
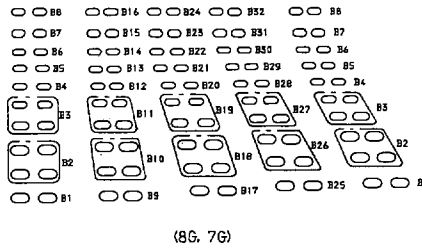
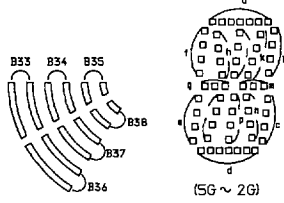
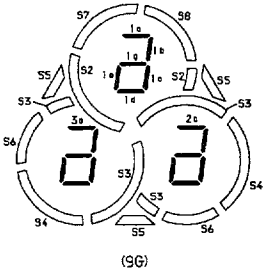
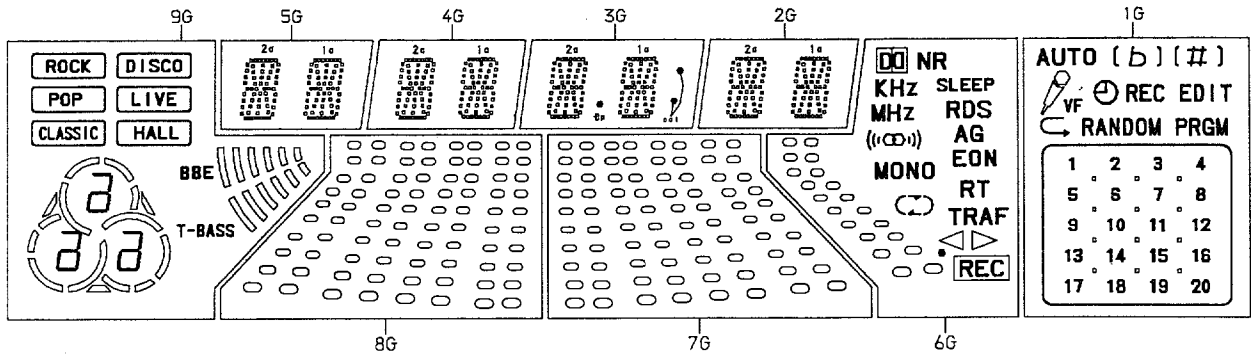

BJ531GK
GRID ASSIGNMENT

ANODE CONNECTION

	9G	8G, 7G	6G	5G, 4G	3G	2G	1G
P1	S8	B32		-	col(F)	-	RANDOM
P2	S2	B24		1d	1d	1d	-
P3	1b	B16	SLEEP	1n	1n	1n	PRGM
P4	1c	B8	B8	1p	1p	1p	EDIT
P5	1e	B31	○	1r	1r	1r	1
P6	1a, 1d, 1g	B23	REC	1e	1e	1e	2
P7	2b	B15	KHz	1c	1c	1c	3
P8	2c	B7	B7	1g	1g	1g	4
P9	2e	B30	MHz	1m	1m	1m	5
P10	2a, 2d, 2g	B22	-	1f	1f	1f	6
P11	3b	B14	DD NR	1b	1b	1b	7
P12	3c	B6	B6	1k	1k	1k	8
P13	3e	B29	RDS	1j	1j	1j	9
P14	3a, 3d, 3g	B21	-	1h	1h	1h	10
P15	S3	B13	-	1a	1a	1a	11
P16	S5	B5	B5	-	col(L)	-	12
P17	S7	B28	-	-	dp	-	13
P18	S4	B20	-	2d	2d	2d	14
P19	S6	B12	-	2n	2n	2n	15
P20	(HALL)	B4	B4	2p	2p	2p	16
P21	(LIVE)	B27	AG	2r	2r	2r	17
P22	(DISCO)	B19	((∞))	2e	2e	2e	18
P23	(CLASSIC)	B11	EON	2c	2c	2c	19
P24	(POP)	B3	B3	2g	2g	2g	20
P25	(ROCK)	B26	RT	2m	2m	2m	AUTO
P26	B36	B18	MONO	2f	2f	2f	VF
P27	B37	B10	TRAF	2b	2b	2b	
P28	B38	B2	B2	2k	2k	2k	REC
P29	B33	B25)	2j	2j	2j	
P30	B34	B17	Σ	2h	2h	2h	{(#)}
P31	B35	B9	(2a	2a	2a	{(b)}
P32	S9 T-BASS	B1	B1	-	-	-	S1
P33	S10	-	-	-	-	-	-
P34	BBE	-	-	-	-	-	-
P35	-	-	-	-	-	-	b #

IC BLOCK DIAGRAM - 1
IC,BA3880S

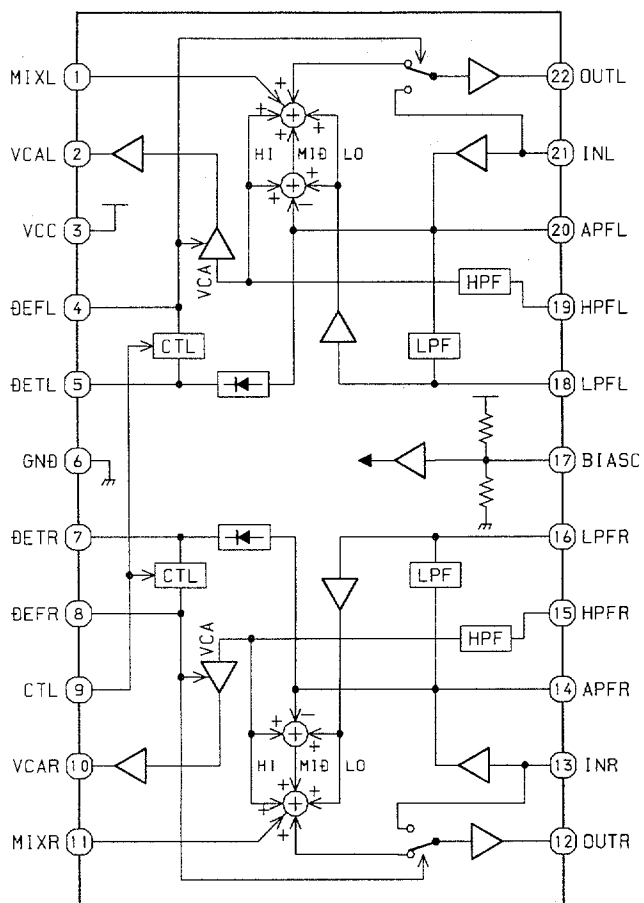

IC,BA3835S

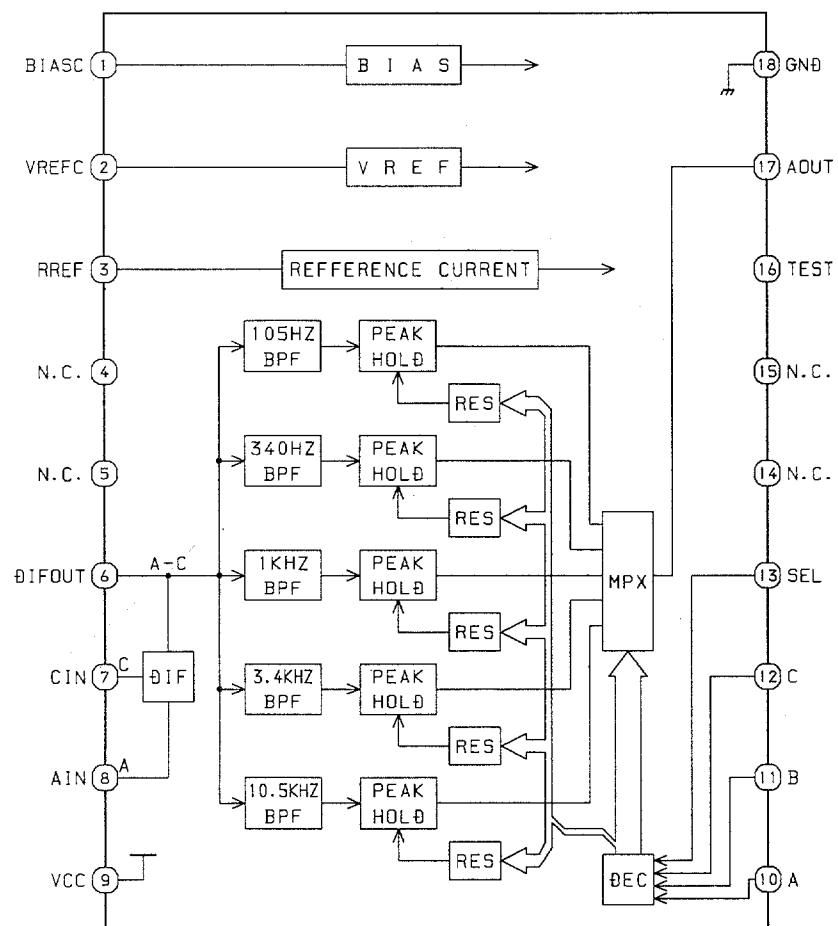

IC,BA7762FS

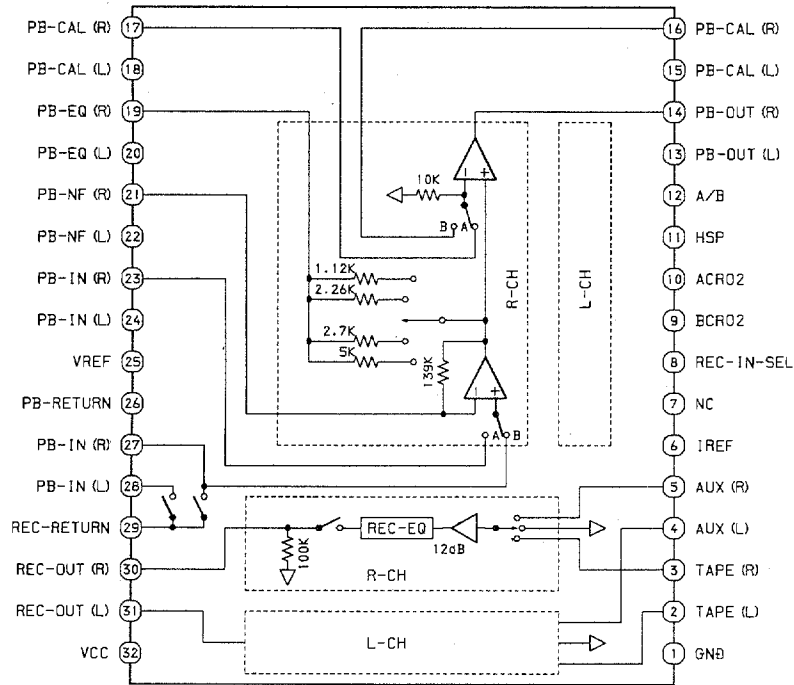

IC,LA1837

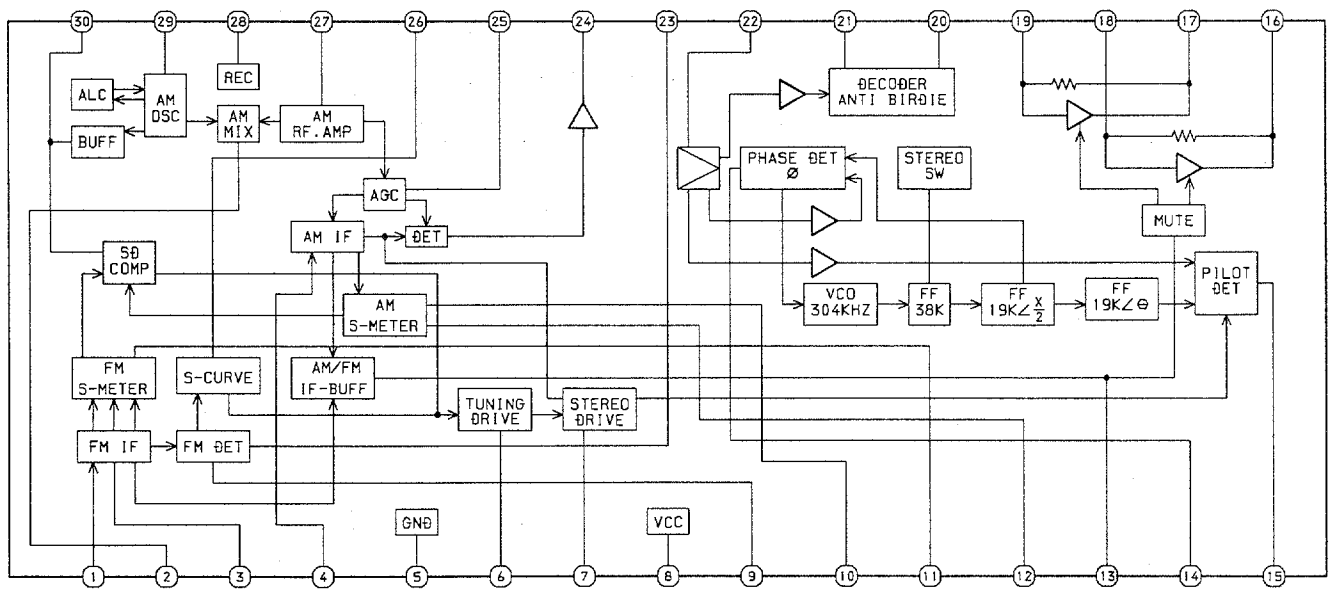

IC DESCRIPTION

IC, LC866548V-5E15

Pin No.	Pin Name	I/O	Description
1	RT-A	I	Rotary encoder A input.
2	RT-B	I	Rotary encoder B input.
3	$\overline{\text{LED-MD}}$	O	"MD" LED ON/OFF output.
4	$\overline{\text{LED-CD}}$	O	"CD " LED ON/OFF output.
5	$\overline{\text{LED-AUX}}$	O	"AUX" LED ON/OFF output.
6	$\overline{\text{LED-TUNER}}$	O	"TUNER" LED ON/OFF output.
7	$\overline{\text{LED-TAPE}}$	O	"TAPE" LED ON/OFF output.
8	HSP	O	Tape deck motor high speed ON/OFF output.
9	$\overline{\text{O-POWER}}$	O	System power supply ON/OFF output.
10	$\overline{\text{O-MUTE}}$	O	System mute ON/OFF output.
11	$\overline{\text{O-CLK-SHIFT}}$	O	U-COM clock shift output.
12	$\overline{\text{RESET}}$	I	Reset input.
13	$\overline{\text{I-HP-MUTE}}$	-	Not connected.
14	I-DISH	I	CD turntable photo sensor A/D converter input.
15	VSS 1	-	GND.
16	CF 1	-	5.76MHz oscillator circuit.
17	CF 2	-	
18	VDD 1	-	Power supply input.
19	$\overline{\text{HOLD}}$	I	Power failure detected input "1" to stop clock and main memory.
20	KEY-1	I	KEY input.(A/D)
21	KEY-2	I	
22	KEY-3	I	
23	I-CD SW	I	CD mechanical switch A/D converter input.
24	I-MIC	I	Microphone input for AUTO VF display.
25	I-TU-SIG/MS	I	Tuner signal and deck music sensor signal input.
26	I-SPEANA	I	A/D input for spectrum analyzer display.
27	I-WRQ/RDS-CLK	I	CD WRQ input . TUNER RDS CLOCK input.
28	I-TM-BASE	I	REFERENCE CLOCK input for timer watch.
29	$\overline{\text{I-RMC}}$	I	System remote control signal input.
30~37	G9~G2	O	FL GRID output G2~G9.
38~43	P32~P27	O	FL SEGMENT output P27~P32.
44	G1	O	FL grid output G1.
45	P26	-	FL SEGMENT output P26.
46	VDD3	-	Power supply input.
47	SPEANA-A/P25	O	Spectrum analyzer band switching output /FL segment P25 output.
48	SPEANA-B/P24	O	Spectrum analyzer band switching output /FL segment P24 output.
49	SPEANA-C/P23	O	Spectrum analyzer band switching output /FL segment P23 output.
50	P22/H-DUBB INH	I/O	FL segment P22 output / high dubbing inhibit input to diode.
51	VP	-	Power supply input for FL display.
52	P21/AM-ST	I/O	FL segment P21 output / AM stereo input to diode.
53	P20/LW	I/O	FL segment P20 output / LW mode data input to diode.
54	P19/SW	I/O	FL segment P19 output / SW mode data input to diode.

Pin No.	Pin Name	I/O	Description
55	P18/FM 1	I/O	FL segment P18 output / FM1 (OIRT) data input to diode.
56	P17/RDS	I/O	FL segment P17 output / RDS data input to diode.
57	P16/ $\overline{\text{BBE}}$	I/O	FL segment P16 output / BBE data input to diode.
58	P15/ $\overline{\text{DSP}}$	I/O	FL segment P15 output / DSP data input to diode.
59	P14/D-SURR	I/O	FL segment P14 output / DOLBY-SURR data input to diode.
60	P13/K-CON	I/O	FL segment P13 output / K-CON data input to diode.
61	P12/ $\overline{\text{DOLBY}}$	I/O	FL segment P12 output / DOLBY data input to diode.
62	P11/WAY	I/O	FL segment P11 output / DECK/WAY MECHA data input to diode.
63	P10/AM-9K/10K	I/O	FL segment P10 output / INITIAL AM 10 kHz step data input to diode.
64	P9/ $\overline{\text{CST 2}}$	I/O	FL segment P9 output / DECK2 cassette detect switch data input.
65	P8/ $\overline{\text{REB}}$	I/O	FL segment P8 output / DECK2 side-B record OK switch data input.
66	P7/ $\overline{\text{CAM 2}}$	I/O	FL segment P7 output / DECK2 CAM switch data input.
67	P6/AUTO 1	I/O	FL segment P6 output / DECK1 AUTO stop signal input.
68	P5/AUTO 2	I/O	FL segment P5 output / DECK2 AUTO stop signal input.
69	P4/ $\overline{\text{CAM 1}}$	I/O	FL segment P4 output / DECK1 CAM switch data input.
70	P3/ $\overline{\text{CST 1}}$	I/O	FL segment P3 output / DECK1 cassette detect switch data input.
71	P2/ $\overline{\text{REA}}$	I/O	FL segment P2 output / DECK2 side A record OK switch data input.
72	VDD 4	-	Power supply input.
73	P1/2092	I/O	FL segment P1 output / SHIFT resistor IC 2092 data input to diode.
74	K-SCAN	O	Switch SCAN timing output.
75	LED/LCK	O	Latch clock output for front shift resistor.
76	PRO-CE	O	PRO LOGIC IC chip enable output. (Not connected.)
77	PLL-CE	O	PLL IC chip enable output.
78	MA-STB	O	Latch strobe output for MAIN PWB.
79	DATA	O	DATA output for MAIN, FRONT, PROLOGIC PWB.
80	CLK	O	CLOCK output for MAIN,FRONT, PROLOGIC PWB.
81	DISH-RVS	O	CD turntable reverse rotation output.
82	DISH-FWD	O	CD turntable forward rotation output.
83	TRAY-OPEN	O	CD TRAY OPEN data output.
84	TRAY-CLOSE	O	CD TRAY CLOSE data output.
85	$\overline{\text{LED}}$ ►►	O	►► LED $\overline{\text{ON/OFF}}$ output.
86	$\overline{\text{LED}}$ ◄◄	O	◄◄ LED $\overline{\text{ON/OFF}}$ output.
87	$\overline{\text{LED}}$ ►	O	► LED $\overline{\text{ON/OFF}}$ output.
88	$\overline{\text{LED}}$ ◄	O	◄ LED $\overline{\text{ON/OFF}}$ output.
89	VSS 2	-	GND.
90	VDD 2	-	Power supply input.
91	$\overline{\text{LED}}$ ■	O	■ LED $\overline{\text{ON/OFF}}$ output.
92	$\overline{\text{LED}}$	O	LED $\overline{\text{ON/OFF}}$ output.
93	SOL 1	O	DECK 1 Solenoid output.
94	SOL 2	O	DECK 2 Solenoid output.
95	O-MOTOR	O	DECK MOTOR $\overline{\text{ON/OFF}}$ output.
96	I- $\overline{\text{IFC/I-SUB Q}}$	I	Tune IF count serial data input /CD SUB Q data input.

Pin No.	Pin Name	I/O	Description
97	I-STEREO/O-SQCLK	I/O	Tuner stereo detected input/CD SQ CLOCK output.
98	I-RDS-DATA/O-DATA	I/O	RDS data input/CD data output.
99	O-CDCE	O	CD CE output.
100	O-CDCLK	O	CD CLOCK output.

IC, LC72131

Pin No.	Pin Name	I/O	Description						
1	XIN	I/O	A crystal oscillator (7.2MHz) is connected between these pins.						
22	XOUT								
2	NC	-	Not used.						
3	CE	I	To enable the IC. Active "H".						
4	DI	I	Digital data input from CPU (LC866548V-5E15) when relevant key is operated. Active "H".						
5	CL	I	To clock in the data DI.						
6	DO	O	Digital data output to CPU (LC866548V-5E15).						
7	T-BASE	O	Outputs a reference clock signal (8Hz) for the clock.						
8	MONO / BEAT	O	Outputs "H" when MONO / BEAT is switched.						
9	FM / SW	O	Output "L" or "H" as follows: <table border="1" style="margin-left: 20px;"> <tr><td colspan="2">2 BAND</td></tr> <tr><td>FM</td><td>SW</td></tr> <tr><td>L</td><td>L</td></tr> </table>	2 BAND		FM	SW	L	L
2 BAND									
FM	SW								
L	L								
10	MW / SW	O	Outputs "L" or "H" as follows: <table border="1" style="margin-left: 20px;"> <tr><td colspan="2">2 BAND</td></tr> <tr><td>MW</td><td>SW</td></tr> <tr><td>L</td><td>H</td></tr> </table>	2 BAND		MW	SW	L	H
2 BAND									
MW	SW								
L	H								
11	IF-MUTE	O	To control internal counter.						
12	IF-IN	I	General purpose counter input.						
13	TUNE	I	Receives "L" when station is tuned.						
14	NC	-	Not used.						
15	AM-IN	I	Receives the AM local oscillator frequency signal.						
16	FM-IN	I	Receives the FM local oscillator frequency signal.						
17	VDD	-	Supply power to IC (+5V).						
18	PD	O	PLL charge pump output.						
19	A-IN	I	The MOS transistor for PLL active low pass filter.						
20	A-OUT	O							
21	VSS	-	Ground.						

IC BLOCK DIAGRAM - 2
IC, BH3864F

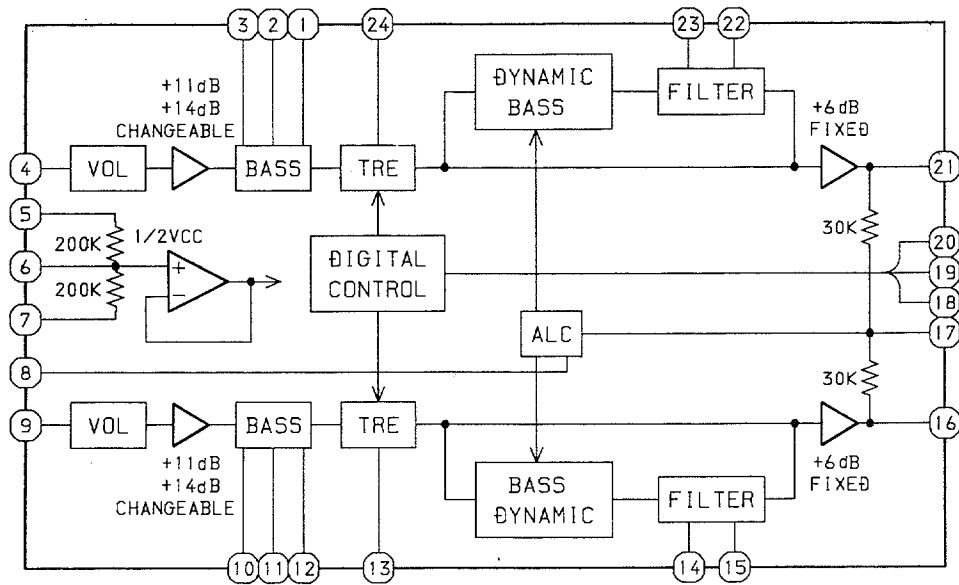

IC, BH3810FS

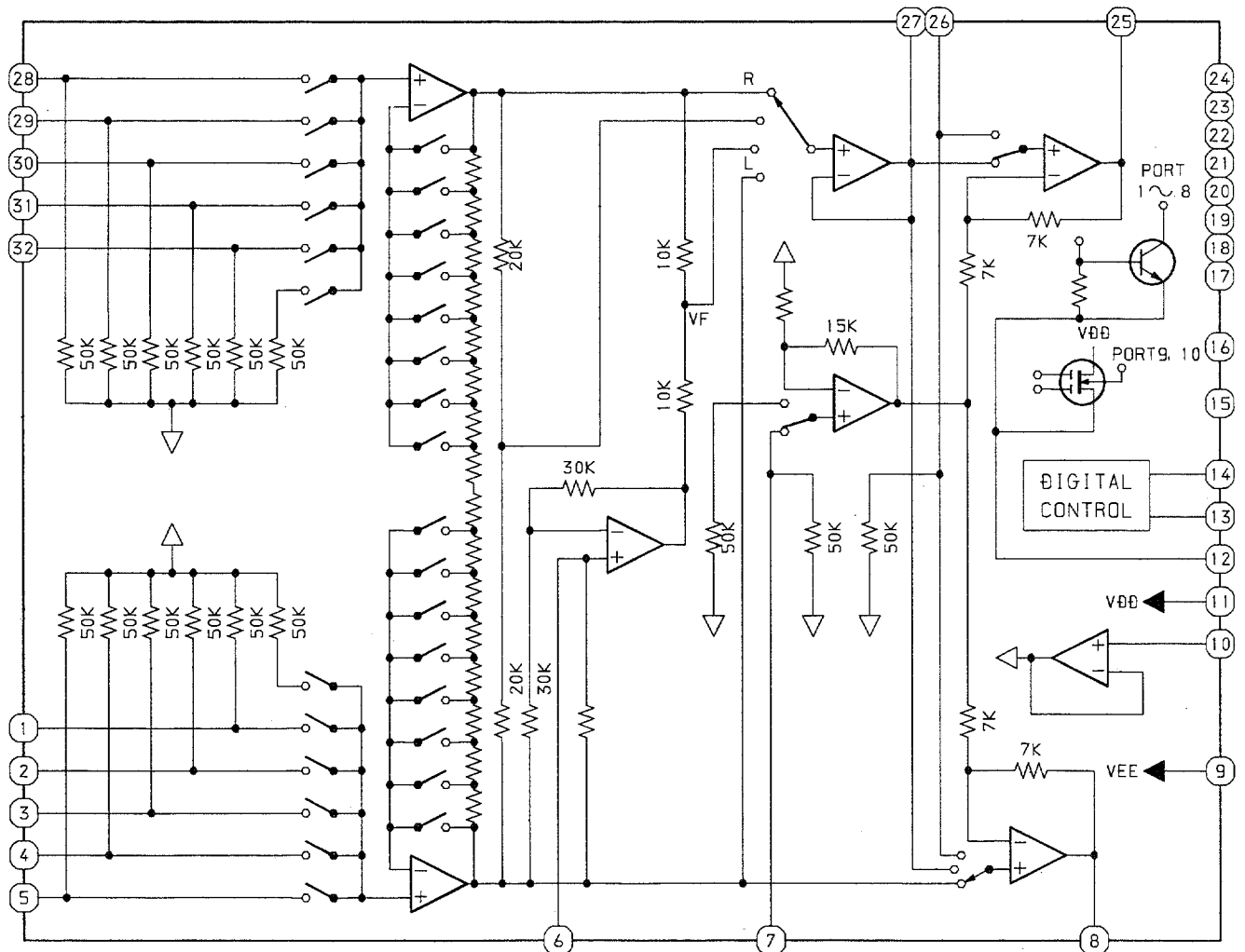

ADJUSTMENT <TUNER / DECK>

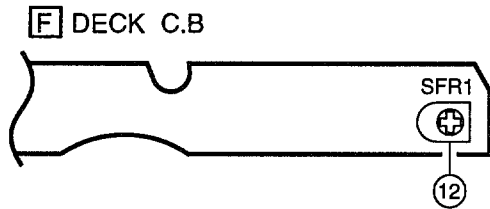
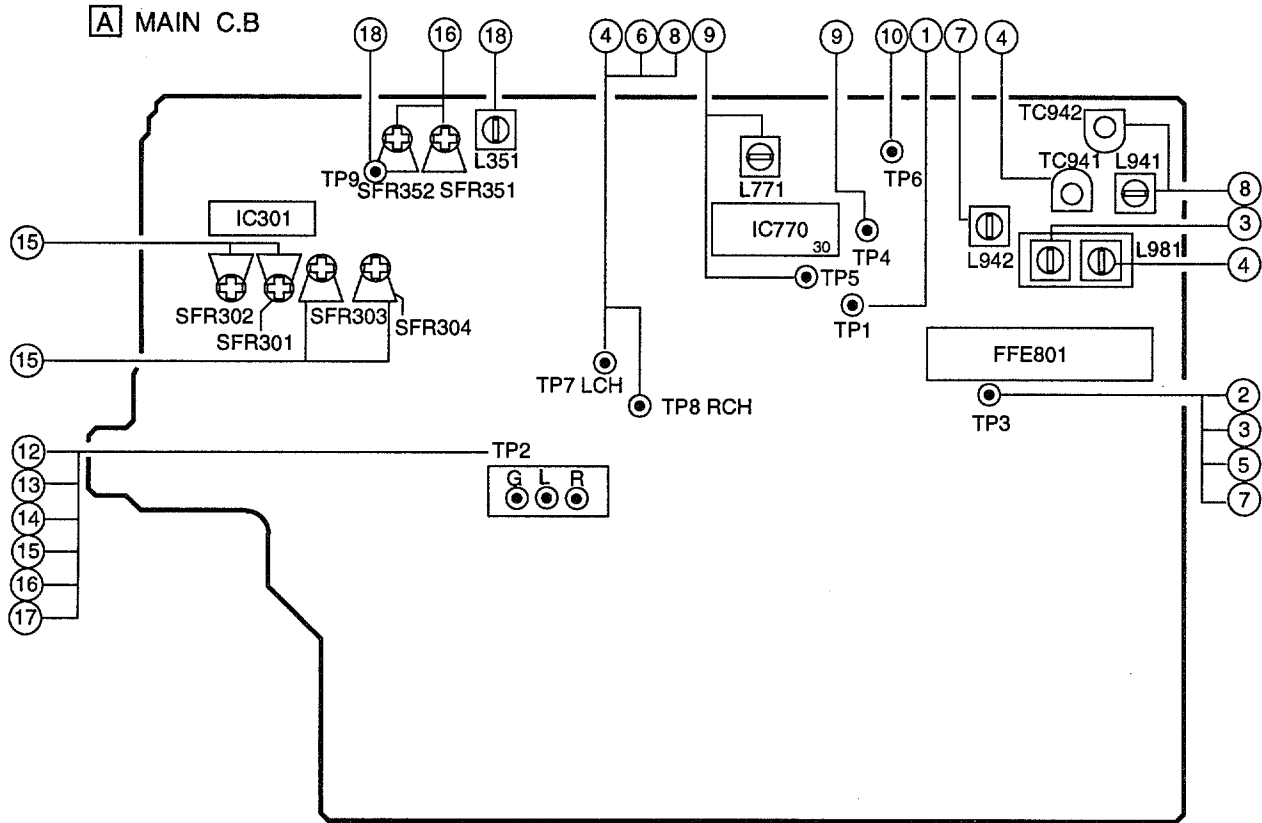

DECK-1 P, DECK-2 R / P / E HEAD

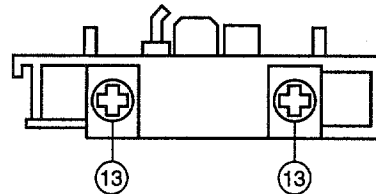

< TUNER SECTION >

1. Clock Check
 Settings : • Test point : TP1
 Method : Set to MW 1710kHz and check that the test point is $2160\text{kHz} \pm 0.045\text{Hz}$.
2. AM(MW) VT Check (LH,A50U,A51U,A54U)
 Settings : • Test point : TP3 (VT)
 Method : Set to AM 1710kHz and check that the test point is $6.0\text{V} \pm 1.0\text{V}$.
3. MW VT Adjustment (HR)
 Settings : • Test point : TP3 (VT)
 • Adjustment location : L981
 Method : Set to MW 1710kHz and adjust L981 so that the test point becomes $8.5\text{V} \pm 0.05\text{V}$. Then set to MW 530kHz and check that the test point is more than 0.3V.
4. AM(MW) Tracking Adjustment
 Settings : • Test point : TP7, TP8
 • Adjustment location :
 L981 1000kHz [LH,A50U,A51U,A54U]
 L981 600kHz [HR]
 TC941 1400kHz [HR]
 Method : The level at 1000kHz is adjusted to MAX by L981. [LH,A50U,A51U,A54U]
 Set up TC941 to center before adjustment. The level at 600 kHz is adjusted to MAX by L981. Then the level at 1400 kHz is adjusted to MAX by TC941.[HR]
5. FM VT Check
 Settings : • Test point : TP3 (VT)
 Method : Set to FM 108.0MHz and check that the test point is less than 8.5V.
 Set to FM 87.5MHz and check that the test point is more than 1.5V.

6. FM Tracking Check
 Settings : • Test point : TP7, TP8
 Method : • Set to FM 98.0MHz and check that the test point is 2 ± 6 dB.
7. SW VT Adjustment (HR)
 Settings : • Test point : TP3 (VT)
 • Adjustment location : L942
 Method : Set to SW 17.9MHz and adjust L942 so that the test point becomes $7.0V \pm 0.05V$.
8. SW Tracking Adjustment (HR)
 Settings : • Test point : TP7, TP8
 • Adjustment location :
 L941 5.9MHz
 TC942 17.9MHz
 Method : Set up TC942 to center before adjustment.
 The level at 5.9MHz is adjust to MAX by L941.
 Then the level at 17.9MHz is adjust to MAX by TC942.
9. DC Balance / Mono Distortion Adjustment
 Settings : • Test point : TP4, TP5
 • Adjustment location : L771
 • Input level : 54dB
 Method : Set to FM 98.0MHz and adjust L771 so that the voltage between TP4 and TP5 becomes $0V \pm 0.04V$.
 Next, check that the distortion is less than 1.3%
10. Auto Stop Level Check
 Settings : • Test point : TP6
 • Input level : adjustable
 Method : Set to FM 98.0 MHz and check that the voltage low about 0.1V. After that voltage high about 7.0V out by 2dB down.
11. Auto Stop Level Check
 AM(MW)
 Settings : • Input level : adjustable
 Method : Set to AM(MW) 1000kHz[A50U,A51U,A54U,LH] 999kHz[HR] and check that the test point is 35 ~ 60dB.
- FM
 Settings : • Input level : adjustable
 Method : Set to FM 98.0MHz and check that the test point is $25dB \pm 10dB$.
- SW (HR)
 Settings : • Input level : adjustable
 Method : Set to FM 12MHz and check that the test point is less than 60 dB.

< DECK SECTION >

12. Tape Speed Adjustment
 Settings : • Test tape : TTA-100
 • Test point : TP2
 • Adjustment location : SFR1
 Method : Play back the test tape and adjust SFR1 so that the frequency counter reads $3000Hz \pm 5Hz$.
13. Head Azimuth Adjustment
 Settings : • Test tape : TTA-300
 • Test point : TP2
 • Adjustment location : Head azimuth adjustment screw
 Method : Play back the 10kHz signal of the test tape and adjust screw so that the output becomes maximum.
 Next, perform on each FWD PLAY and REV PLAY mode.
14. PB Frequency Response Check (DECK 1, DECK 2)
 Settings : • Test tape : TTA-300
 • Test point : TP2
 Method : Play back the 315Hz and 10kHz signals of the test tape and check that the output ratio of the 10kHz signal with respect to that of the 315Hz signal is within 2dB.
15. PB Sensitivity Adjustment (DECK 1, DECK 2)
 Settings : • Test tape : TTA-200
 • Test point : TP2
 • Adjustment location :
 SFR301 (DECK 1, Lch)
 SFR302 (DECK 1, Rch)
 SFR303 (DECK 2, Lch)
 SFR304 (DECK 2, Rch)
 Method : Play back the test tape and adjust SFRs so that the output level of the test point becomes 330mV[Deck1], 300 mV[Deck 2].
16. REC/PB Frequency Response Adjustment
 Settings : • Test tape : TTA-602
 • Test point : TP2
 • Input signal : 1kHz / 10kHz (LINE IN)
 • Adjustment location : SFR351 (Lch)
 SFR352 (Rch)
 Method : Apply a 1kHz signal and REC mode.
 Then adjust OSC attenuator so that the output level at the TP2 becomes 210mV. Record and play back the 1kHz and 10kHz signals and adjust SFRs so that the output of the 10kHz signals becomes $0dB \pm 0.5dB$ with respect to that of the 1kHz signal.
17. REC/PB Sensitivity Check
 Settings : • Test tape : TTA-602
 • Test point : TP2
 • Input signal : 1kHz (LINE IN)
 Method : Apply a 1kHz signal and REC mode. Then adjust OSC attenuator so that the output level at the TP2 becomes 21mV. Record and play back the 1kHz signals and check that the output is $17mV \pm 3dB$.
18. Bias OSC Frequency Adjustment
 Settings : • Test point : TP9
 • Adjustment location : L351
 Method : Set to the REC mode. Adjust L351 so that the frequency counter of the test point is $85kHz \pm 1kHz$.

PRACTICAL SERVICE FIGURE

<TUNER SECTION>

<FM SECTION>

IHF Sensitivity : 4dB ± 6dB
(THD 3%) [at 87.5 / 98.0MHz / 108.0MHz]
S/N 50dB Quieting sensitivity :
30dB ± 6dB
[at 87.5 / 98.0 / 108.0MHz]
Signal to noise ratio : More than 65dB
[at 98.0MHz]
Distortion : Less than 2%
[at 98.0MHz]
Stereo separation : More than 25dB
[at 98.0MHz]
Intermediate frequency : 10.7MHz

<AM(MW) SECTION>

Sensitivity : 55dB ± 5dB
(S/N 20 dB) [at 600kHz (LH,A50U,A51U,A54U)]
[at 603kHz (HR)]
53dB ± 5dB
[at 1000 / 1400kHz (LH,A50U,
A51U,A54U)]
[at 999 / 1404kHz (HR)]
Distortion : Less than 1.5%
[at 1000kHz (LH,A50U,A51U,A54U)]
[at 999kHz (HR)]
Intermediate frequency : 450kHz

<SW SECTION> (HR)

Sensitivity : 38dB ± 5dB (5.9MHz)
(S/N 20dB) 33dB ± 5dB (12.0MHz)
30dB ± 8dB (17.9MHz)
Distortion : Less than 1.5% (12.0MHz)
Intermediate frequency : 450kHz

<DECK SECTION>

Tape speed : 3000Hz ± 45Hz
Wow & flutter : Less than 0.18% (R.M.S)
Take-up torque : 30 ~ 55g-cm (FWD, REV)
F.F & REW torque : 75 ~ 180g-cm (F.F)
75 ~ 130g-cm (REW)
Back tension : 2 ~ 7g-cm
PB Output level : 330mV ± 1dB (DECK1)
300mV ± 1dB (DECK2)
REC/PB Output level : 180mV ± 1dB
Distortion (REC/PB) : Less than 2.0% (NORM, CrO2)
Noise level (PB) : Less than 2mV (NORM, DOLBY OFF/
ON B.C)
Less than 1.5mV (CrO2, DOLBY OFF/
ON B.C)
Noise level (REC/PB) : Less than 2mV (NORM, DOLBY OFF/
ON B.C)
Less than 1.5mV (CrO2, DOLBY OFF/
ON B.C)
Crosstalk : More than 60dB (1kHz, NORM)
Channel separation : More than 30dB (1kHz, NORM)
Erasing ratio : More than 60dB (at 125Hz, CrO2)
Test tape : NORM : TTA-602
CrO2 : TTA-615

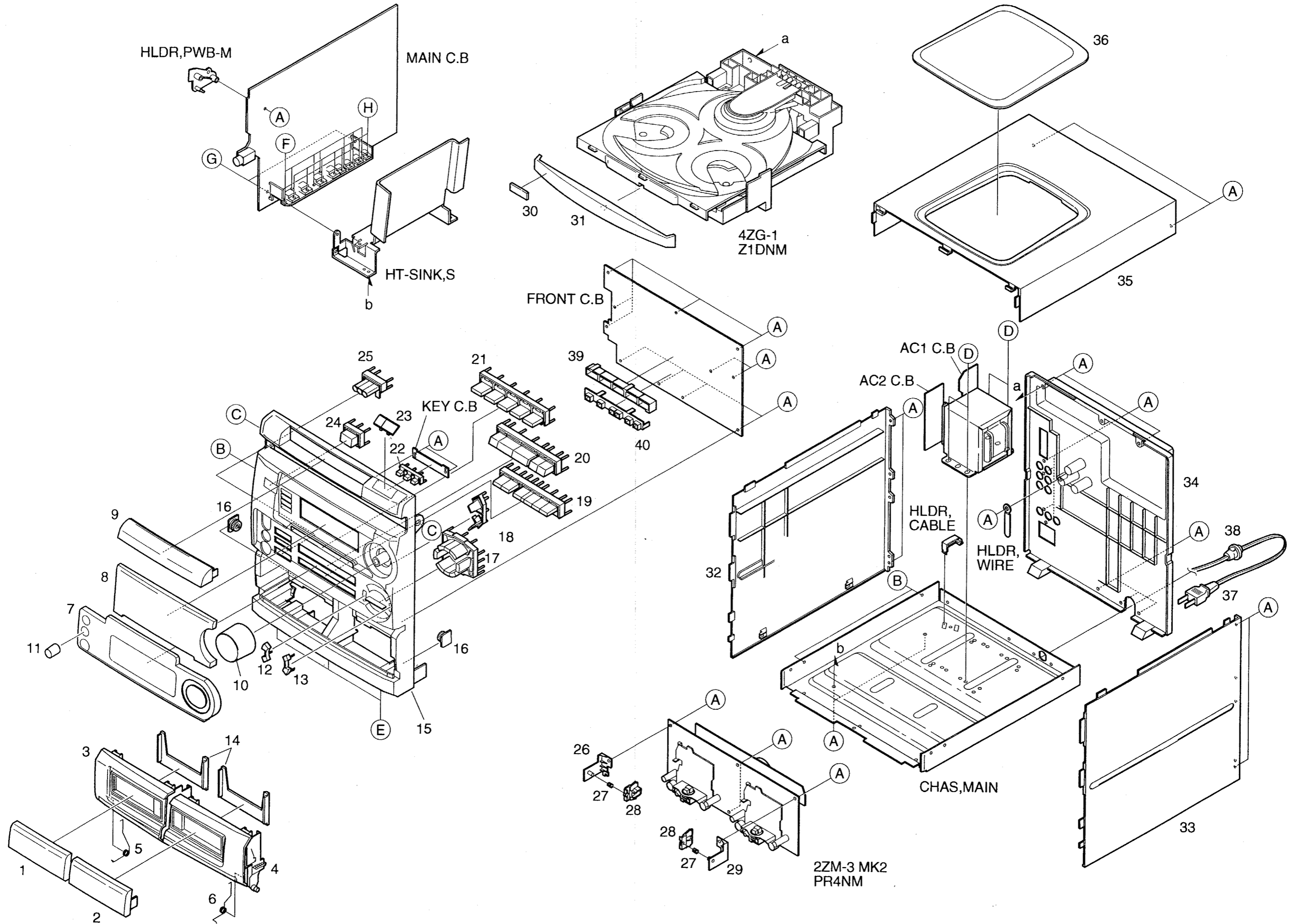

MECHANICAL PARTS LIST 1 / 1

If can't understand for Description please kindly refer to "REFERENCE NAME LIST".

REF. NO.	PART NO.	KANRI NO.	DESCRIPTION	REF. NO.	PART NO.	KANRI NO.	DESCRIPTION
1	87-NF6-041-010		WINDOW, CASS 1	24	87-NF6-025-010		KEY, POWER
2	87-NF6-042-010		WINDOW, CASS 2	25	87-NF6-034-010		KEY, KARAOKE
3	87-NF6-013-010		BOX, CASS 1E<50U, 51U, 54U>	26	87-NF4-216-010		HLDR, LOCK 1
3	87-NF6-011-010		BOX, CASS 1H<HR, LH>	27	82-NF5-228-010		SPR-C, LOCK
4	87-NF6-014-010		BOX, CASS 2E<50U, 51U, 54U>				
4	87-NF6-012-010		BOX, CASS 2H<HR, LH>	28	82-NF5-229-010		PLATE, LOCK (*)
5	82-NF5-218-010		SPR-T, EJECT 1(SIN)	29	87-NF4-217-010		HLDR, LOCK 2
6	82-NF5-219-010		SPR-T, EJECT 2(SIN)	30	82-NE6-067-010		BADGE, AIWA 30N
7	87-NF6-015-010		PANEL, FR H<EXP 50U, 54U>	31	87-NF6-018-010		PANEL, TRAY E
7	87-NF6-016-010		PANEL, FR U<50U, 54U>	32	87-NF6-022-010		PANEL, LEFT
8	87-NF6-046-010		WINDOW, DISPLAY H<HR, LH>	33	87-NF6-023-010		PANEL, RIGHT
8	87-NF6-044-010		WINDOW, DISPLAY U<50U, 54U>	34	87-NF6-055-010		CABI, REAR HRJSTNM<HR>
8	87-NF6-006-010		WINDOW, DISPLAY U1<51U>	34	87-NF6-056-010		CABI, REAR LHSTNM<LH>
9	87-NF6-043-010		WINDOW, CD	34	87-NF6-059-010		CABI, REAR U1STNM<51U>
10	87-NF6-036-010		KNOB, RTRY VOL	34	87-NF6-052-010		CABI, REAR USTNM<50U, 54U>
11	87-NF6-037-010		KNOB, RTRY MIC<50U, 54U>	35	87-NF6-021-010		PANEL, TOP
12	87-NF6-040-010		PANEL, T-BASS	36	86-NF6-007-010		WINDOW, TOP
13	87-NF6-039-010		PANEL, BBE	△ 37	87-050-079-010		AC CORD ASSY, E BLK<HR, LH>
14	86-NF6-061-010		REFLECTOR, CASS	△ 37	87-050-053-010		AC CORD ASSY, U-2<50U, 51U, 54U>
15	87-NF6-001-010		CABI, FR H<HR, LH>	△ 38	87-085-185-010		BUSHING, AC CORD(E)<HR, LH>
15	87-NF6-002-010		CABI, FR U<50U, 54U>	△ 38	87-085-189-010		BUSHING, AC CORD(U)<50U, 51U, 54U>
15	87-NF6-005-010		CABI, FR U1<51U>	39	87-NF6-201-010		GUIDE, FUN
16	87-063-165-010		OIL-DMPR, 150	40	87-NF6-202-010		GUIDE, PLAY
17	87-NF6-026-010		KEY, CURSOR H<EXP 50U, 54U>	A	87-067-703-010		BVT2+3-10 W/O SLOT
17	87-NF6-027-010		KEY, CURSOR U<50U, 54U>	B	87-721-096-410		QT2+3-10 W/O SLOT
18	87-NF6-028-010		KEY, MIC<EXP 50U, 54U>	C	87-721-097-410		QT2+3-12 W/O SLOT
19	87-NF6-032-010		KEY, REC H	D	87-078-019-010		S-SCREW, IT+4-6 SWCH12A
20	87-NF6-049-010		KEY, ASSY PLAY	E	87-067-688-010		BVTT+3-6
21	87-NF6-029-010		KEY, FUNCTION	F	87-067-758-010		BVT2+3-12 W/O SLOT
22	87-NF6-045-010		KEY, DISC	G	87-067-633-010		BVT2+3.8 W/CONVEX
23	87-NF6-024-010		KEY, CD	H	87-067-579-010		BVT2+3.8 W/O SLOT

ACCESSORIES / PACKAGE LIST

If can't understand for Description please kindly refer to "REFERENCE NAME LIST".

REF. NO.	PART NO.	KANRI NO.	DESCRIPTION
1	87-NF6-910-019		IB, U(ESF)M-50<50U, 54U>
1	87-NF6-912-019		IB, U(ESF)M-51<51U>
1	87-NF6-901-019		IB, H(ECA)M<HR>
1	87-NF6-902-019		IB, LH(ECA)M<LH>
2	87-A90-064-016		FEEDER-ANT, FM (SHS)
3	87-006-225-019		ANT, LOOP ANT NC2<EXP HR>
3	87-A90-054-016		ANT, LOOP AM-CONC<HR>
4	87-043-095-019		ANT, WIRE<HR>
5	87-NF6-630-019		RC UNIT, RC-7AS06
△ 6	87-A90-312-016		PLUG, CONVERSION WTN-1157R1<LH, HR>

TAPE MECHANISM EXPLODED VIEW 1 / 1

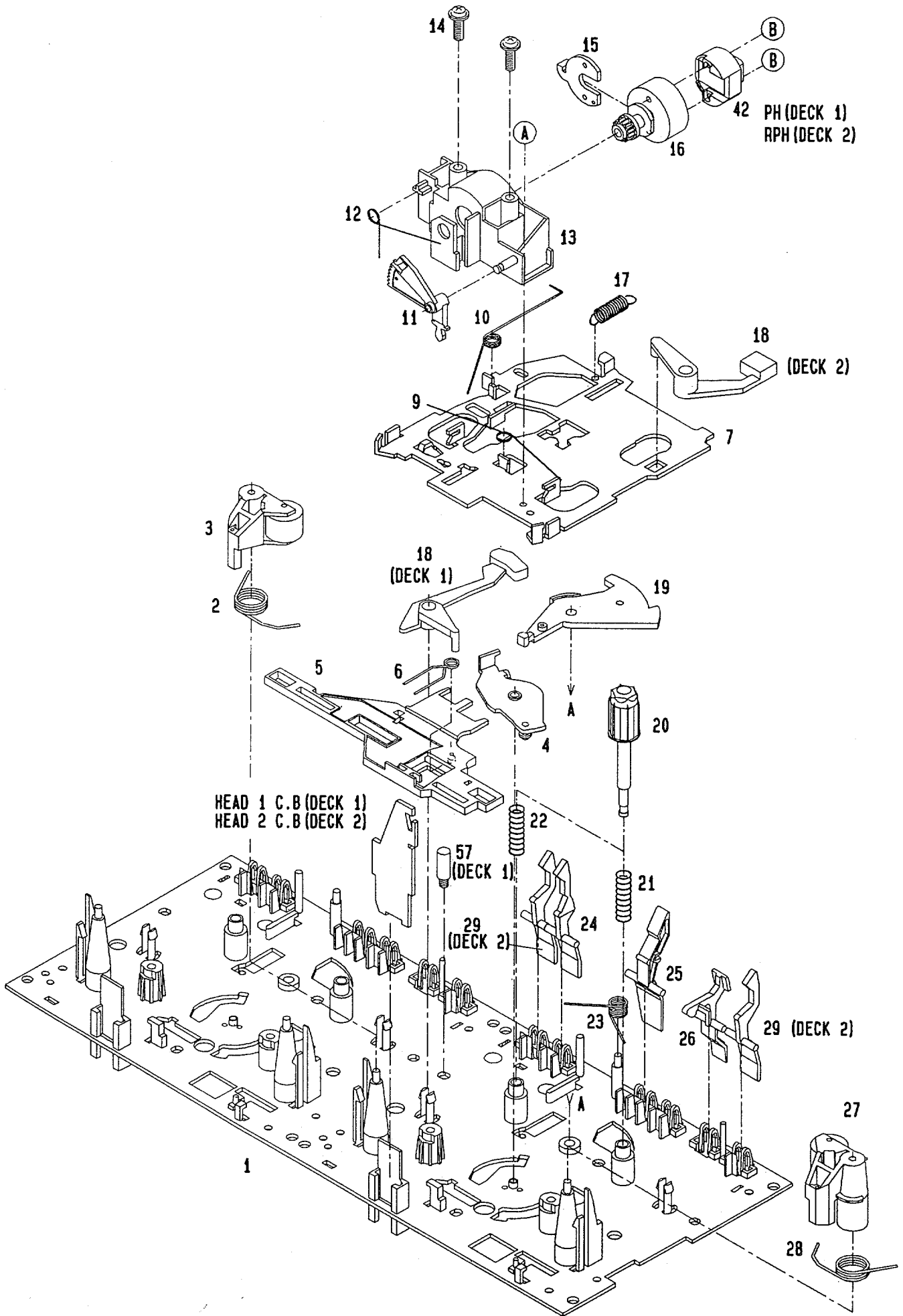

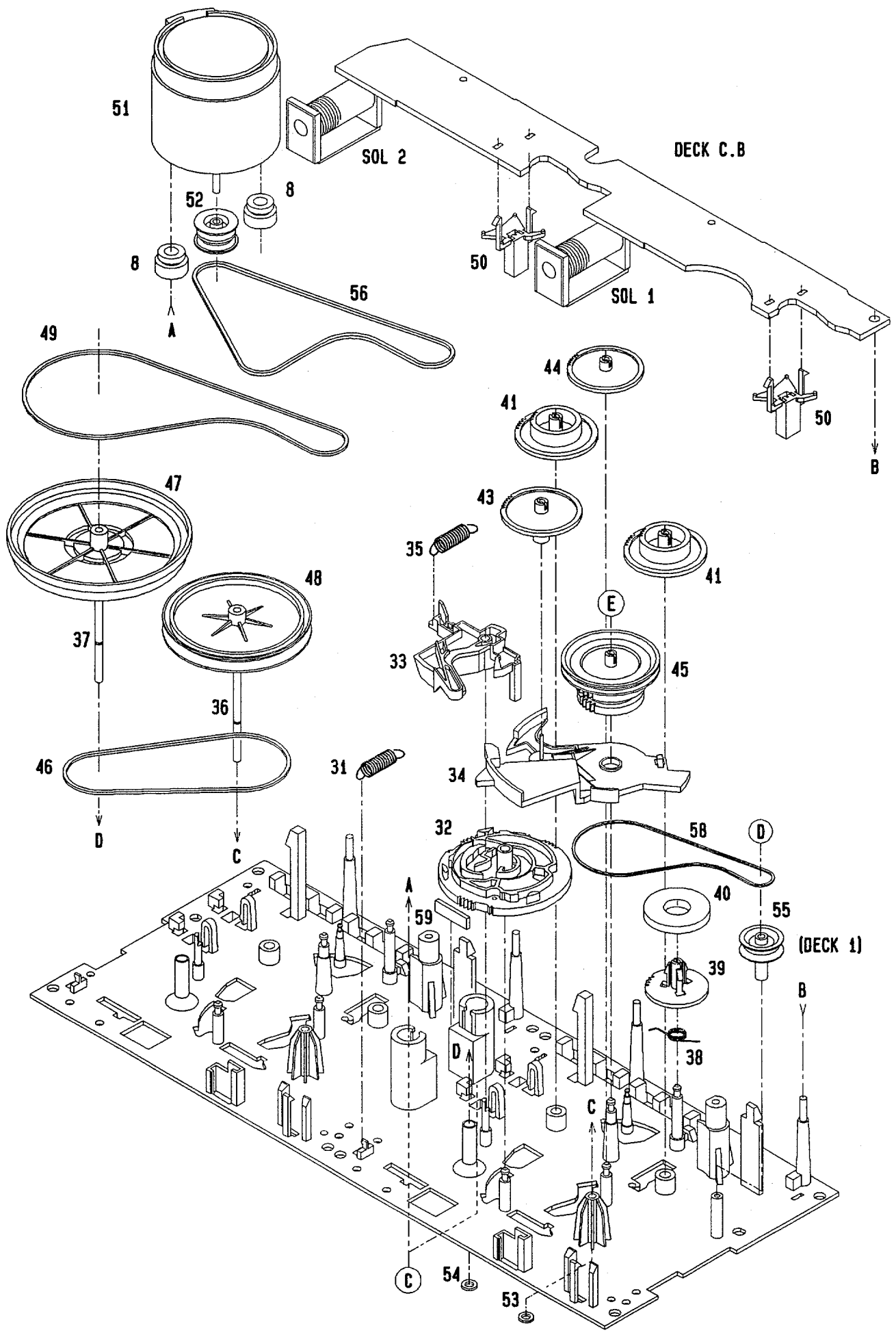

TAPE MECHANISM PARTS LIST 1 / 1

If can't understand for Description please kindly refer to "REFERENCE NAME LIST".

REF. NO.	PART NO.	KANRI NO.	DESCRIPTION	REF. NO.	PART NO.	KANRI NO.	DESCRIPTION
1	82-ZM3-301-519		CHAS ASSY, M2	35	82-ZM1-265-119		SPR-E, TRIG
2	82-ZM1-258-110		SPR-T, PINCH L	36	82-ZM1-236-019		CAPSTAN N 2-41.5
3	82-ZM1-341-010		LVR ASSY, PINCH L2	37	82-ZM1-239-019		CAPSTAN N 2.2-41.7
4	82-ZM1-333-010		PLATE, LINK 2	38	82-ZM1-322-019		SPR-T, FR60
5	82-ZM1-266-11K		LVR, DIR	39	82-ZM1-220-219		GEAR, IDLER
6	82-ZM1-214-010		SPR-T, DIR	40	82-ZM3-616-019		RING MAGNET 4
7	82-ZM1-206-81K		CHAS, HEAD	41	82-ZM1-216-31K		GEAR, REEL
8	82-ZM3-307-019		CUSH-G, DIA3.7-8-3.2	42	87-A90-319-010		HEAD, PH HADKH2 FPC
9	82-ZM1-269-219		SPR-T, BRG	42	87-A90-320-010		HEAD, RPH HADKH5 FPC
10	82-ZM1-219-119		SPR-T, LINK	43	82-ZM1-225-21K		GEAR, FR
11	82-ZM1-210-119		GEAR, H T	44	82-ZM1-226-019		GEAR, REW
12	82-ZM1-213-019		SPR-T, HEAD	45	82-ZM3-333-310		SLIP DISK ASSY 2
13	82-ZM1-207-619		GUIDE, TAPE	46	82-ZM1-338-010		BELT FR4
14	86-ZM4-206-010		S-SCREW, AZIMUTH	47	82-ZM1-349-110		FLY-WHL ASSY, R W(DECK 2)
15	82-ZM1-314-119		PLATE, HEAD	47	82-ZM3-338-110		FLY-WHL ASSY, R3 W(DECK 1)
16	82-ZM1-208-119		HLDR, HEAD	48	82-ZM1-348-010		FLY-WHL ASSY, L W(DECK 2)
17	82-ZM1-218-019		SPR-E, HB	48	82-ZM1-348-010		FLY-WHL ASSY, L W(DECK 1)
18	82-ZM1-263-110		LVR, EJECT L (DECK 1)	49	82-ZM3-329-210		BELT, SBU R2
18	82-ZM1-264-010		LVR, EJECT R (DECK 2)	50	82-ZM1-245-210		HLDR, IC
19	82-ZM1-222-21K		LVR, PLAY	51	87-045-347-019		MOT, SHU2L 70(M1)
20	82-ZM1-217-319		REEL TABLE	52	82-ZM3-221-010		PULLEY, MOT 2M
21	82-ZM1-244-510		SPR-C, BT	53	82-ZM1-288-019		SH, 1.63-3.2-0.5 SLT
22	82-ZM1-285-310		SPR-C, BT L	54	80-ZM6-243-019		SH, 1.75-3.6-0.5 SLT
23	82-ZM1-257-019		SPR-T, CAS	55	82-ZM3-335-210		PULLEY, COUPLER M3 (DECK 1)
24	82-ZM1-241-319		LVR, MC	56	82-ZM3-337-010		BELT, SBU MOT 2
25	82-ZM1-242-019		LVR, CAS	57	82-ZM3-339-010		SHAFT, COUPLER N3 (DECK 1)
26	82-ZM1-243-019		LVR, STOP	58	86-ZM1-206-010		BELT, MAIN L
27	82-ZM1-344-110		LVR ASSY, PINCH R2	59	82-ZM3-340-010		SH, BELT D2
28	82-ZM1-259-110		SPR-T, PINCH R	A	85-ZM3-202-010		SCREW, TG
29	82-ZM1-240-11K		LVR, REC (DECK 2)	B	80-ZM6-207-019		V+1.6-7
30	82-ZM1-298-010		SPR-P, EARTH	C	82-ZM3-318-019		S-SCRW MOTOR M2
31	82-ZM1-255-319		SPR-E, LVR DIR	D	87-B10-043-010		W-P, 0.99-4-0.25 SLT
32	82-ZM3-305-01K		GEAR, CAM M2	E	82-ZM3-334-010		PW, 2.16-6-0.4
33	82-ZM1-227-21K		LVR, TRIG				
34	82-ZM3-306-11K		LVR, FR M2				

SPEAKER PARTS LIST (SX-NA54)

If can't understand for Description please kindly refer to "REFERENCE NAME LIST".

REF. NO.	PART NO.	KANRI NO.	DESCRIPTION
1	87-NSG-001-019		PANEL, FR R
2	87-NSG-002-019		PANEL, FR L
3	87-NSG-007-019		GRILLE, FRAME ASSY R
4	87-NSG-008-019		GRILLE, FRAME ASSY L
5	87-NSG-602-019		SPKR, W 160
6	87-NSG-604-019		SPKR, T 60
7	87-NSG-605-019		SPKR, CORD

SPEAKER PARTS LIST (SX-FNA51/FNS50)

If can't understand for Description please kindly refer to "REFERENCE NAME LIST".

REF. NO.	PART NO.	KANRI NO.	DESCRIPTION
1	87-NS6-001-019		PANEL, FR
2	87-NS6-002-019		PANEL, BA
3	87-NS6-004-019		HLDL, SQ
4	87-NS5-606-019		SPKR, 80
5	87-NS6-611-019		SPKR, CORD Y/B
6	87-NS4-611-019		SPKR, CORD
7	87-NS6-007-019		GRILLE, FRAME ASSY
8	87-NSA-602-019		SPKR, W 160
9	86-NS5-604-019		SPKR, T 80
10	87-NS4-610-019		SPKR, CODE Y/B
11	87-NS6-601-019		SPKR, CORD

SPEAKER PARTS LIST (SX-ANS70)

If can't understand for Description please kindly refer to "REFERENCE NAME LIST".

REF. NO.	PART NO.	KANRI NO.	DESCRIPTION
1	87-NS5-001-019		PANEL, FR R
2	87-NS5-002-019		PANEL, FR L
3	87-NS5-025-019		GRILLE, FRAME ASSY R
4	87-NS5-026-019		GRILLE, FRAME ASSY L
5	87-NS4-611-019		SPKR, CORD
6	87-NS6-611-019		SPKR, CORD Y/B
7	87-NS5-602-019		SPKR, W 160
8	87-NS5-604-019		SPKR, MID
9	87-NS5-605-019		SPKR, T 50

SPRING APPLICATION POSITION

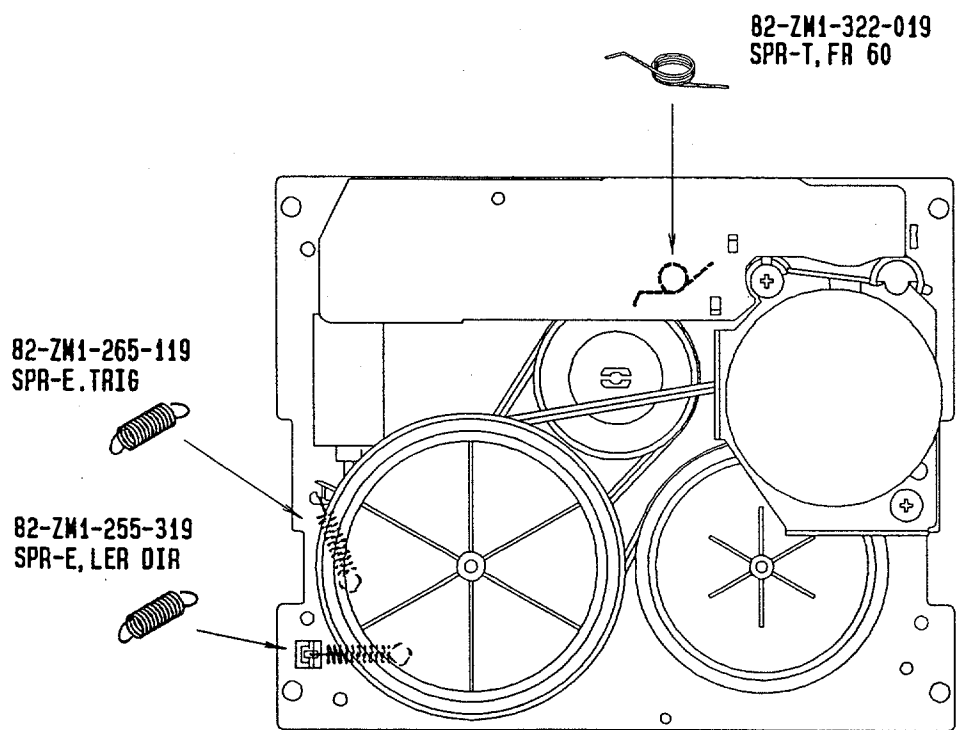
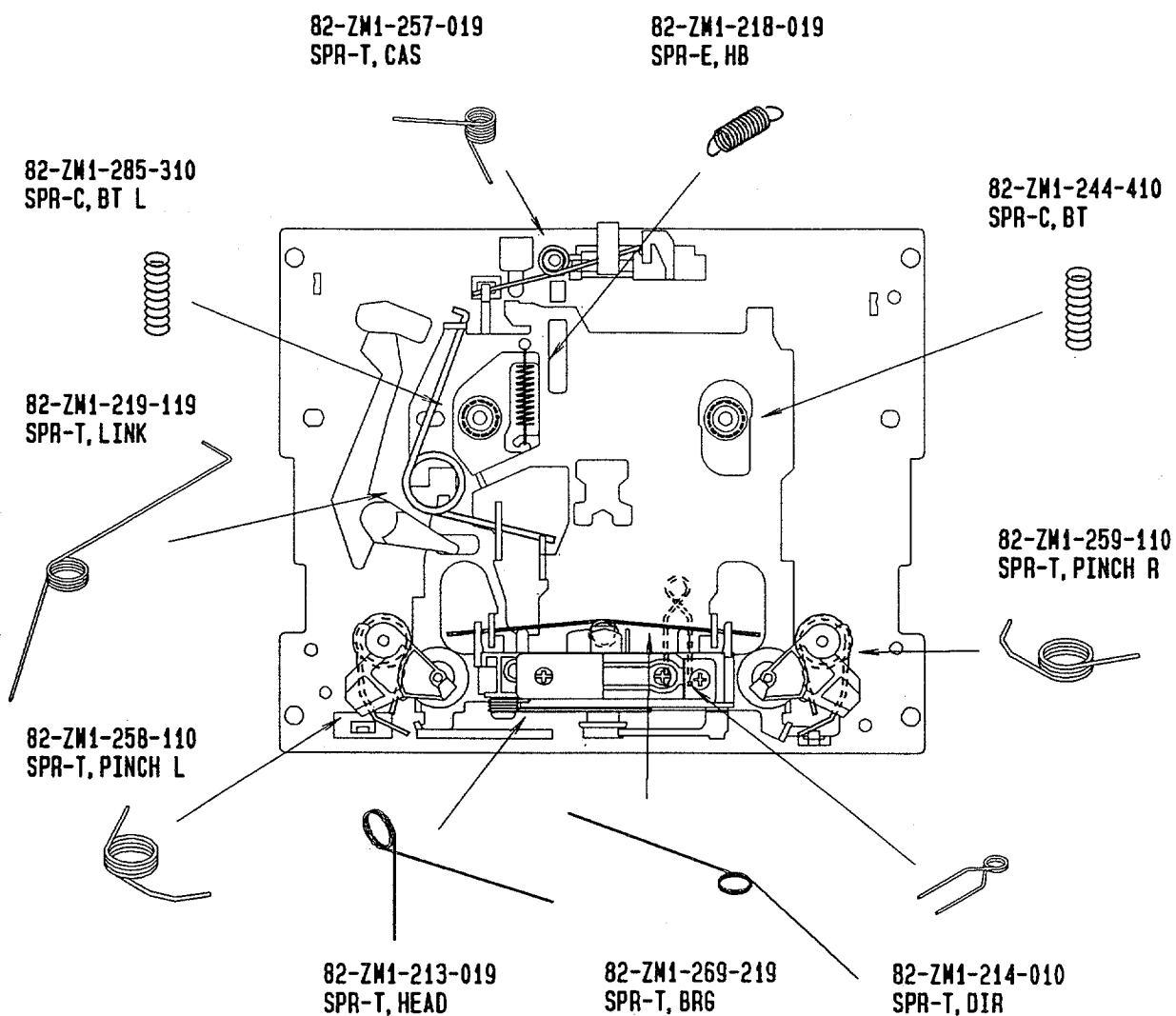

REFERENCE NAME LIST

ELECTRICAL SECTION

DESCRIPTION	REFERENCE NAME
ANT	ANTENNAS
C-	CHIP
C-CAP	CAP, CHIP
C-CAP TN	CAP, CHIP TANTALUM
C-COIL	COIL, CHIP
C-DI	DIODE, CHIP
C-DIODE	DIODE, CHIP
C-FET	FET, CHIP
C-FOTR	FILTER, CHIP
C-JACK	JACK, CHIP
C-LED	LED, CHIP
C-RES	RES, CHIP
C-SFR	SFR, CHIP
C-SLIDE SW	SLIDE SWITCH, CHIP
C-SW	SWITCH, CHIP
C-TR	TRANSISTOR, CHIP
C-VR	VOLUME, CHIP
C-ZENER	ZENER, CHIP
CAP, CER	CAP, CERA-SOL
CAP, E	CAP, ELECT
CAP, M/F	CAP, FILM
CAP, TC	CAP, CERA-SOL
CAP, TC-U	CAP, CERA-SOL SS
CAP, TN	CAP, TANTALUM
CERA FIL	FILTER, CERAMIC
CF	FILTER, CERAMIC
DL	DELAY LINE
E/CAP	CAP, ELECT
FILT	FILTER
FLTR	FILTER
FUSE RES	RES, FUSE
MOT	MOTOR
P-DIODE	PHOTO DIODE
P-SNSR	PHOTO SENSER
P-TR	PHOTO TRANSISTOR
POLY VARI	VARIABLE CAPACITOR
PPCAP	CAP, PP
PT	POWER TRANSFORMER
PTR, RES	PTR, MELF
RC	REMOTE CONTROLLER
RES NF	RES, NON-FLAMMABLE
RESO	RESONATOR
SHLD	SHIELD
SOL	SOLENOID
SPKR	SPEAKER
SW, LVR	SWITCH, LEVER
SW, RTRY	SWITCH, ROTARY
SW, SL	SWITCH, SLIDE
TC CAP	CAP, CERA-SOL
THMS	THERMISTOR
TR	TRANSISTOR
TRIMER	CAP, TRIMMER
TUN-CAP	VARIABLE CAPACITOR
VIB, CER	RESONATOR, CERAMIC
VIB, XTAL	RESONATOR, CRYSTAL
VR	VOLUME
ZENER	DIODE, ZENER

MECHANICAL SECTION

DESCRIPTION	REFERENCE NAME
ADHESHIVE	SHEET ADHESHIVE
AZ	AZIMUTH
BAR-ANT	BAR-ANTENNA
BAT	BATTERY
BATT	BATTERY
BRG	BEARING
BTN	BUTTON
CAB	CABINET
CASS	CASSETTE
CHAS	CHASSIS
CLR	COLLAR
CONT	CONTROL
CRSR	CURSOR
CU	CUSHION
CUSH	CUSHION
DIR	DIRECTION
DUBB	DUBBING
FL	FRONT LOADING
FLY-WHL	FLYWHEEL
FR	FRONT
FUN	FUNCTION
G-CU	G-CUSHION
HDL	HANDOL
HIMERON	CLOTH
HINGE, BAT	HINGE, BATTERY
HLDR	HOLDER
HT-SINK	HEAT SINK
IB	INSTRUCTION BOOKLET
IDLE	IDLER
IND, L-R	INDICATOR, L-R
KEY, CONT	KEY, CONTROL
KEY, PRGM	KEY, PROGRAM
KNOB, SL	KNOB, SLIDE
LBL	LABEL
LID, BATT	LID, BATTERY
LID, CASS	LID, CASSETTE
LVR	LEVER
P-SP	P-SPRING
PANEL, CONT	PANEL, CONTROL
PANEL, FR	PANEL, FRONT
PRGM	PROGRAM
PULLY, LOAD MO	PULLY, LOAD MOTOR
RBN	RIBBON
S-	SPECIAL
SEG	SEGMENT
SH	SHEET
SHLD-SH	SHIELD-SHEET
SL	SLIDE
SP	SPRING
SP-SCREW	SPECIAL-SCREW
SPACER, BAT	SPACER, BATTERY
SPR	SPRING
SPR-P	P-SPRING
SPR-PC-PUSH	P-SPRING, C-PUSH
T-SP	T-SPRING
TERM	TERMINAL
TRIG	TRIGGER
TUN	TUNING
VOL	VOLUME
W	WASHER
WHL	WHEEL
WORM-WHL	WORM-WHEEL

サービス技術ニュース	
番号	連絡内容
G- -	
G- -	
G- -	

アイワ株式会社
AIWA CO.,LTD.

9620450, 750038

Tokyo Japan

〒110 東京都台東区池之端1-2-11 ☎03 (3827) 3111 (代表)

Printed in Singapore