

aiwa

NSX - 200
NSX - 230
CA - DW550
CA - DW556

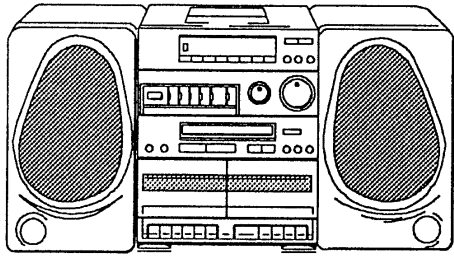

CARRY COMPONENT SYSTEM

- BASIC TAPE MECHANISM : TN - 21ZSW
- BASIC CD MECHANISM : KSL - 2101A
- TYPE. HRA,HA (200)/EA,KA,ZA,LHA (230)
- TYPE. UA (DW550/DW556)

[SUPPLEMENT] [REVISION PUBLISHING]

- A board in NSX - 230 (LHA), CA - DW550 and 556 (UA) was changed.
- For NSX - 230 (EA, KA or ZA) and NSX - 200 (HRA or HA), refer to S/M code No.0101, 0195 or 09 - 938 - 031 - 90T.

MANUAL
SERVICE

SPECIFICATIONS

NSX - 230

TUNER SECTION

<LH model>

FM 87.5-108.0MHz
Antenna : Whip antenna

AM 530-1,710kHz (10kHz)
531-1,602kHz (9kHz)
Antenna : Ferrite bar antenna

<E, K, Z models>

FM 87.5-108.0MHz
Antenna : Whip antenna

MW 522-1,611kHz (9kHz)
530-1,600kHz (10kHz)
Antenna : Ferrite bar antenna

LW 153-288kHz
Antenna : Ferrite bar antenna

•Design and specifications are subject to change without notice.

ALTERNATION LIST

MECHANICAL PARTS LIST

PART NO. CHANGED TO	REF. NO.	PART NO.	カンリ NO.	DESCRIPTION	COMMON MODEL	Q'TY
	1	S1-023-230-401		FRONT CABINET (NSX-230)		1

■ ACCESSORIES/PACKAGE LIST

PART NO. CHANGED TO	REF. NO.	PART NO.	カンリ NO.	DESCRIPTION	COMMON MODEL	Q,TY
	1	S4-400-191-000		INSTRUCTION BOOKLET (NSX-230)		1
	2	S1-400-121-000		POWER CORD SET (NSX-230)		1
	3	SR-CNS-X23-000		REMOTE CONTROLLER ASSY (NSX-230)		1

ELECTRICAL MAIN PARTS LIST (NSX - 230 LH/CA - DW550, 556)

DESCRIPTION で判断できない物は“REFERENCE NAME LIST”を参照してください。
 If can't understand for Description please kindly refer to “REFERENCE NAME LIST”.

REF. NO	PART NO.	カリ NO.	DESCRIPTION	REF. NO	PART NO.	カリ NO.	DESCRIPTION
IC				C107	87-018-202-080		CAP, TC-U 6800P-50
	87-017-680-010	IC, TA8176SN		C108	87-018-202-080		CAP, TC-U 6800P-50
	87-002-268-019	IC, LA1851N		C111	87-010-221-089		CAP, E 470-10
	87-001-376-010	IC, LC7218		C130	87-018-114-089		CAP, TC-U 39P-50 SL
	87-017-681-010	IC, TA8126S		C131	87-018-113-089		CAP, TC-U 33P-50 SL
TRANSISTOR				C132	87-018-119-089		CAP, TC-U 100P-50
	89-319-233-089	TR, 2SC1923(0)		C133	87-018-119-089		CAP, TC-U 100P-50
	87-026-287-089	TR, DTC143ES		C134	87-018-119-089		CAP, TC-U 100P-50
	89-501-614-080	FET, 2SK161Y		C135	87-018-119-089		CAP, TC-U 100P-50
	89-502-464-089	FET, 2SK246Y		C136	87-018-134-089		CAP, TC-U 0.01-16 Y
	89-318-154-089	TR, 2SC1815Y		C137	87-010-263-089		CAP, E 100-10
	87-026-214-089	TR, DTA114YS		C138	87-018-134-089		CAP, TC-U 0.01-16 Y
	87-026-286-089	TR, DTA143ES		C139	87-010-402-089		CAP, E 2.2-50 SME
DIODE				C140	87-018-134-089		CAP, TC-U 0.01-16 Y
	87-020-465-089	DIODE, 1SS133		C144	87-018-196-089		CAP, TC-U 1500P-16 X
TUNNER C. B				C149	87-018-124-089		CAP, TC-U 270P-50
C1	87-018-119-089	CAP, TC-U 100P-50		C151	87-010-263-089		CAP, E 100-10
C2	87-018-100-089	CAP, TC-U 4.7P-50 SL		C152	87-018-134-089		CAP, TC-U 0.01-16 Y
C3	87-018-104-089	CAP, TC-U 10P-50		C155	87-018-134-089		CAP, TC-U 0.01-16 Y
C8	87-018-127-089	CAP, TC-U 470P-50 B		C156	87-018-131-089		CAP, TC-U 1000P-50
C10	87-018-104-089	CAP, TC-U 10P-50		C157	87-018-131-089		CAP, TC-U 1000P-50
C11	87-018-100-089	CAP, TC-U 4.7P-50 SL		C161	87-018-134-089		CAP, TC-U 0.01-16 Y
C12	87-018-128-089	CAP, TC-U 560P-50 B		C163	87-018-118-089		CAP, TC-U 82P-50 B
C16	87-018-134-089	CAP, TC-U 0.01-16 Y		C165	87-018-134-089		CAP, TC-U 0.01-16 Y
C17	87-018-208-089	CAP, TC-U 0.047-50 F		C175	87-018-122-089		CAP, TC-U 180P-50 B
C18	87-018-104-089	CAP, TC-U 10P-50		C186	87-018-134-089		CAP, TC-U 0.01-16 Y
C19	87-018-101-089	CAP, TC-U 5.6P-50 SL		C200	87-010-374-089		CAP, E 47-10
C20	87-018-134-089	CAP, TC-U 0.01-16 Y		C450	87-018-117-089		CAP, TC-U 68P-50 SL
C21	87-018-131-089	CAP, TC-U 1000P-50		C451	87-018-119-089		CAP, TC-U 100P-50
C22	87-018-108-089	CAP, TC-U 20P-50 SL		C452	87-018-195-089		CAP, TC-U 1200P-16 X
C23	87-018-125-089	CAP, TC-U 330P-50 B		C453	87-018-195-089		CAP, TC-U 1200P-16 X
C28	87-018-118-089	CAP, TC-U 82P-50 B		C455	87-018-127-089		CAP, TC-U 470P-50B
C29	87-018-134-089	CAP, TC-U 0.01-16 Y		C456	87-018-106-089		CAP, TC-U 15P-50
C30	87-018-134-089	CAP, TC-U 0.01-16 Y		CF1	87-008-261-010		FLTR, SFE10.7MA5-A
C31	87-018-134-089	CAP, TC-U 0.01-16 Y		CF3	87-008-261-010		FLTR, SFE10.7MA5-A
C51	87-018-104-089	CAP, TC-U 10P-50		IFT1	87-008-470-019		IFT, FM(QUAD)PS
C52	87-018-134-089	CAP, TC-U 0.01-16 Y		L1	87-003-098-089		COIL, 2.2UH
C53	87-018-134-089	CAP, TC-U 0.01-16 Y		L2	87-003-143-089		COIL, 4.7UH
C70	87-018-134-089	CAP, TC-U 0.01-16 Y		L3	87-006-247-010		COIL, RF FM4-1/2 TS
C71	87-018-205-089	CAP, TC-U 0.022-25 F		L4	87-006-247-010		COIL, RF FM4-1/2 TS
C72	87-010-248-089	CAP, E 220-10 SME		L5	87-006-247-010		COIL, RF FM4-1/2 TS
C73	87-010-402-089	CAP, E 2.2-50 SME		L6	87-007-283-019		COIL, OSC AMPS
C74	87-018-134-089	CAP, TC-U 0.01-16 Y		L7	S7-800-641-000		ANT COIL
C75	87-018-202-080	CAP, TC-U 6800P-50		S1-800-051-000		FERRITE BAR	
C76	87-018-123-089	CAP, TC-U 220P-50		L10	87-007-272-010		COIL, OSC DC-DC
C77	87-010-401-089	CAP, E 1-50 SME		L11	87-003-133-019		COIL, 0.22UH
C79	87-010-401-089	CAP, E 1-50 SME		L14	87-003-149-089		COIL, 47UH
C80	87-010-401-089	CAP, E 1-50 SME		L15	87-005-239-089		COIL, 100UH
C81	87-010-546-089	CAP, E 0.33-50 SME		MFT1	87-008-460-019		FLTR, CFMT 450PS
C84	87-018-209-089	CAP, TC-U 0.1		SFR1	87-024-173-089		SFR, 22K DIA6V
C85	87-018-134-089	CAP, TC-U 0.01-16 Y		SFR2	87-024-172-089		SFR, 10K
C86	87-010-404-089	CAP, E 4.7-50 SME		TC1	87-011-219-089		CAP, TRIMMER 10P VCT
C88	87-018-134-089	CAP, TC-U 0.01-16 Y		VC1	87-002-730-019		VARI-CAP, SVC203SPA
C89	87-018-126-089	CAP, TC-U 390P-50 B		VC2	87-002-730-019		VARI-CAP, SVC203SPA
C90	87-018-119-089	CAP, TC-U 100P-50		VC3	87-002-730-019		VARI-CAP, SVC203SPA
C91	87-018-205-089	CAP, TC-U 0.022-25 F		VC4	81-754-634-019		VARI-CAP, KV1260TS2
C92	87-010-378-089	CAP, E 10-16 SME		X1	87-030-243-019		VIB, XTAL 7.2MHZ (LN-A22-4)
C93	87-018-126-089	CAP, TC-U 390P-50 B		X2	87-030-218-019		VIB, CER KBR457HS15
C94	87-018-104-089	CAP, TC-U 10P-50					
C95	87-018-134-089	CAP, TC-U 0.01-16 Y					
C96	87-010-544-089	CAP, E 0.1-50					
C105	87-010-545-089	CAP, E 0.22-50					
C106	87-010-545-089	CAP, E 0.22-50					

IC BLOCK DIAGRAM

IC,TA8126S

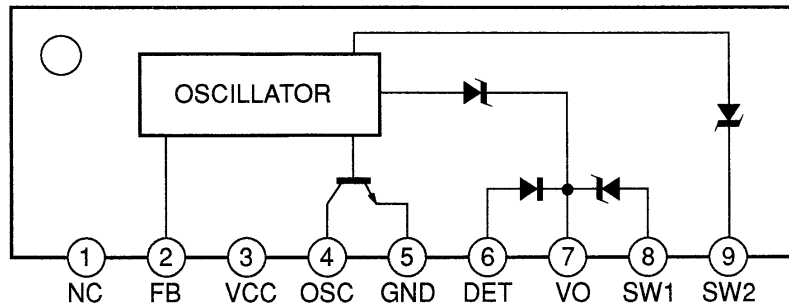

IC,TA8176SN

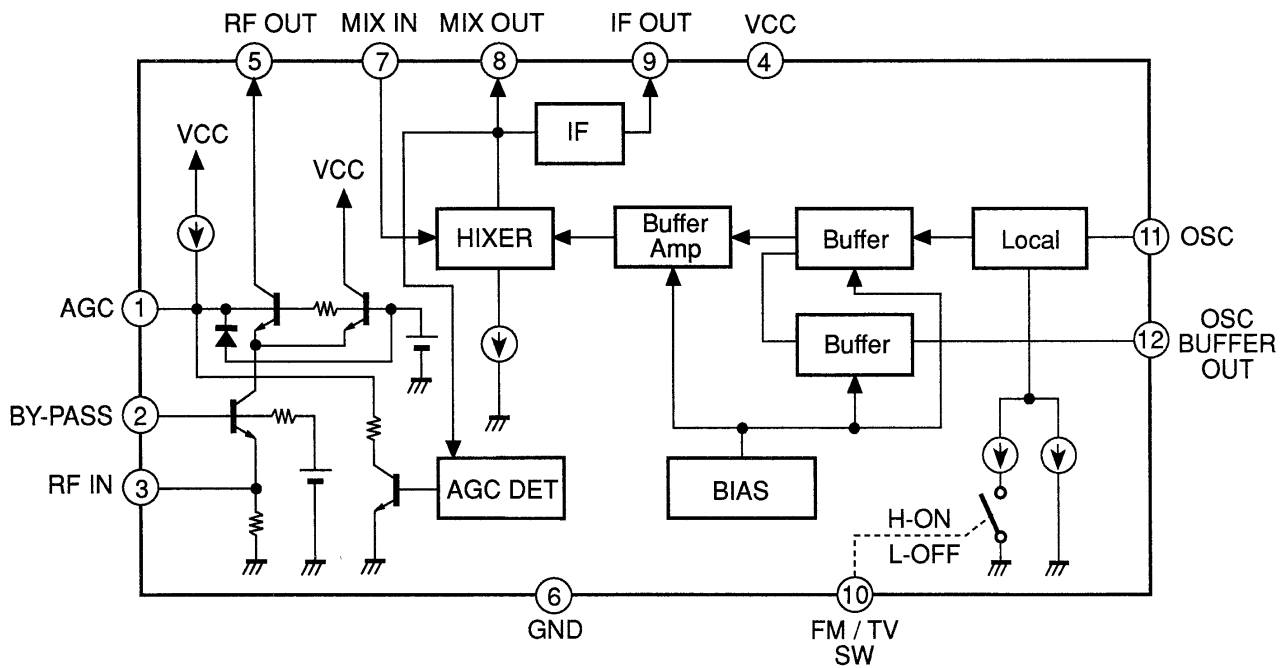

See the LCX - 01 for the IC BLOCK DIAGRAM and IC DESCRIPTION below.

LCX - 01	NSX - 200/230/CA - DW550/556
LA1851N	LA1851N
LC7218M	LC7218M

BLOCK DIAGRAM (TUNER : NSX - 230 LH/CA - DW550, 556)

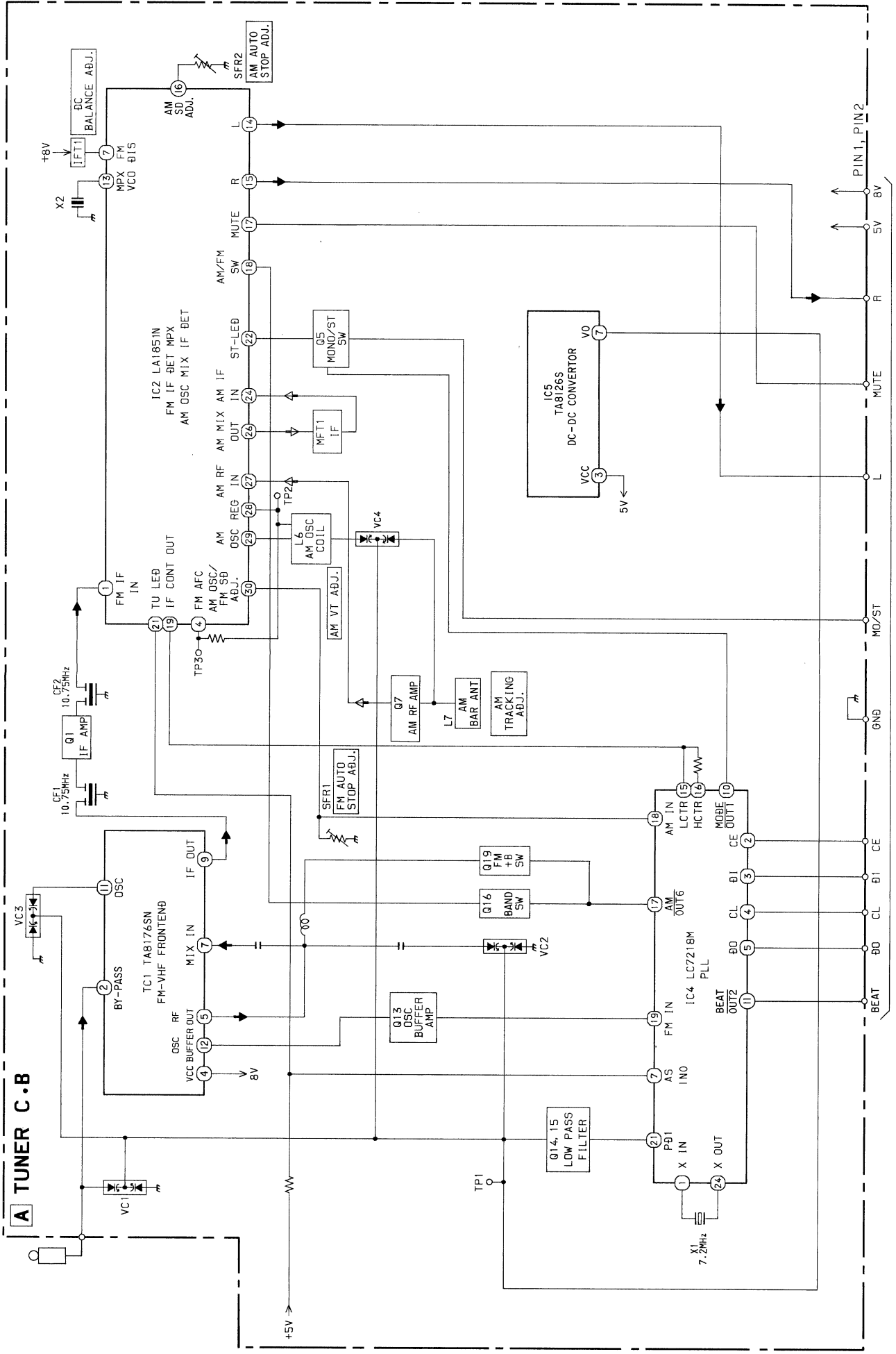

1 2 3 4 5 6 7 8 9 10 11 12 13 14

A TUNER C.B

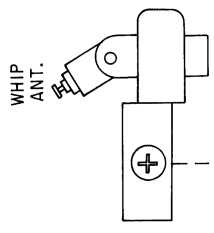
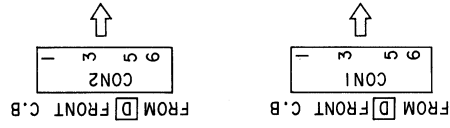
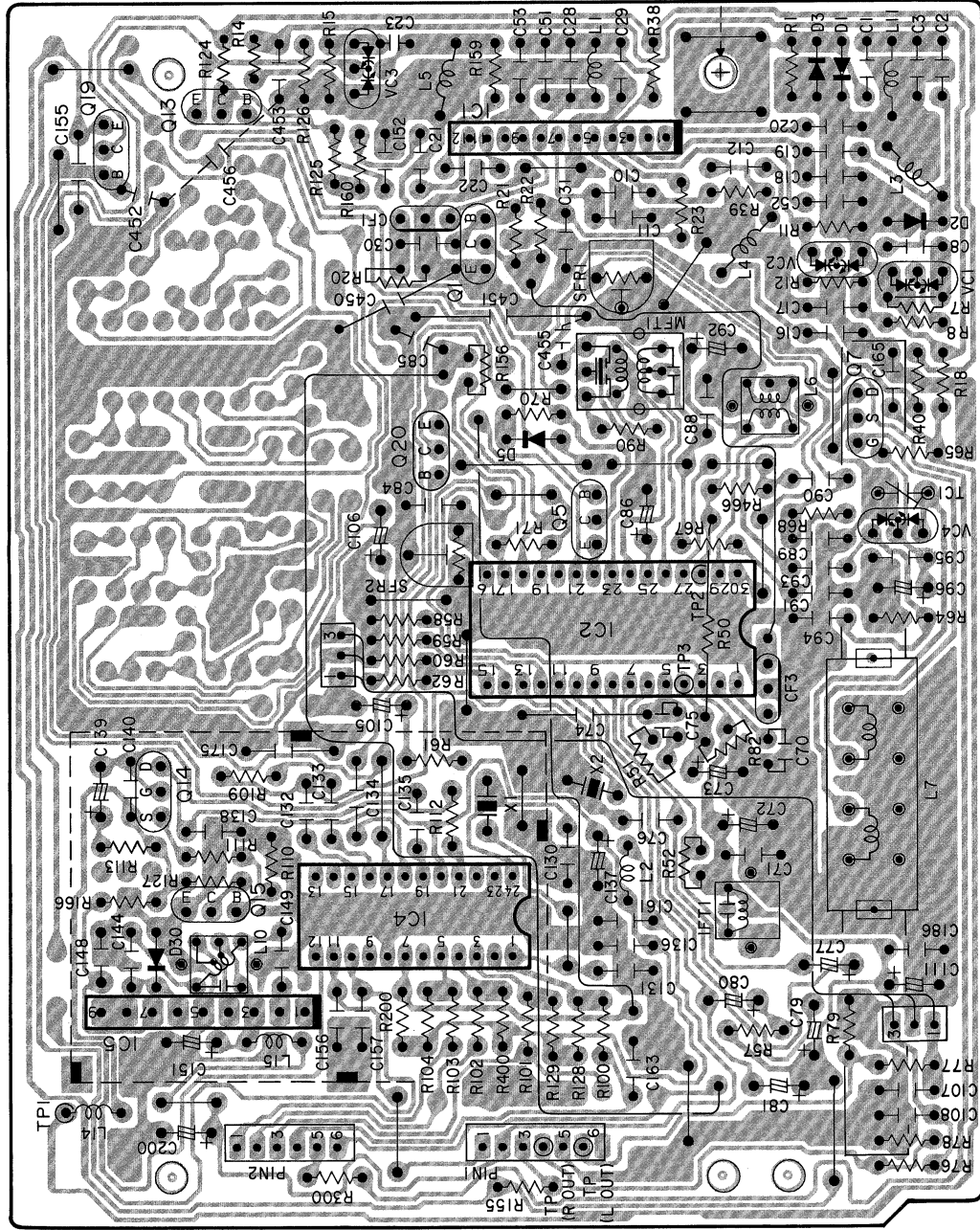

REFERENCE NAME LIST

ELECTRICAL SECTION

DESCRIPTION	REFERENCE NAME
ANT	ANTENNAS
C-	CHIP
C-CAP	CAP, CHIP
C-CAP TN	CAP, CHIP TANTALUM
C-COIL	COIL, CHIP
C-DI	DIODE, CHIP
C-DIODE	DIODE, CHIP
C-FET	FET, CHIP
C-FOTR	FILTER, CHIP
C-JACK	JACK, CHIP
C-LED	LED, CHIP
C-RES	RES, CHIP
C-SFR	SFR, CHIP
C-SLIDE SW	SLIDE SWITCH, CHIP
C-SW	SWITCH, CHIP
C-TR	TRANSISTOR, CHIP
C-VR	VOLUME, CHIP
C-ZENER	ZENER, CHIP
CAP, CER	CAP, CERA-SOL
CAP, E	CAP, ELECT
CAP, M/F	CAP, FILM
CAP, TC	CAP, CERA-SOL
CAP, TC-U	CAP, CERA-SOL SS
CAP, TN	CAP, TANTALUM
CERA FIL	FILTER, CERAMIC
CF	FILTER, CERAMIC
DL	DELAY LINE
E/CAP	CAP, ELECT
FILT	FILTER
FLTR	FILTER
FUSE RES	RES, FUSE
MOT	MOTOR
P-DIODE	PHOTO DIODE
P-SNSR	PHOTO SENSER
P-TR	PHOTO TRANSISTOR
POLY VARI	VARIABLE CAPACITOR
PPCAP	CAP, PP
PT	POWER TRANSFORMER
PTR, RES	PTR, MELF
RC	REMOTE CONTROLLER
RES NF	RES, NON-FLAMMABLE
RESO	RESONATOR
SHLD	SHIELD
SOL	SOLENOID
SPKR	SPEAKER
SW, LVR	SWITCH, LEVER
SW, RTRY	SWITCH, ROTARY
SW, SL	SWITCH, SLIDE
TC CAP	CAP, CERA-SOL
THMS	THERMISTOR
TR	TRANSISTOR
TRIMMER	CAP, TRIMMER
TUN-CAP	VARIABLE CAPACITOR
VIB, CER	RESONATOR, CERAMIC
VIB, XTAL	RESONATOR, CRYSTAL
VR	VOLUME
ZENER	DIODE, ZENER
サージサプレッサ	SERGESUPPRESSOR
セラコン	CAP, CERA

サービス技術ニュース	
番号	連絡内容
G - -	
G - -	
G - -	

MECHANICAL SECTION

DESCRIPTION	REFERENCE NAME
ADHESHIVE	SHEET ADHESHIVE
AZ	AZIMUTH
BAR-ANT	BAR-ANTENNA
BAT	BATTERY
BATT	BATTERY
BRG	BEARING
BTN	BUTTON
CAB	CABINET
CASS	CASSETTE
CHAS	CHASSIS
CLR	COLLAR
CONT	CONTROL
CRSR	CURSOR
CU	CUSHION
CUSH	CUSHION
DIR	DIRECTION
DUBB	DUBBING
FL	FRONT LOADING
FLY-WHL	FLYWHEEL
FR	FRONT
FUN	FUNCTION
G-CU	G-CUSHION
HDL	HANDOL
HIMERON	CLOTH
HINGE, BAT	HINGE, BATTERY
HLDR	HOLDER
HT-SINK	HEAT SINK
IB	INSTRUCTION BOOKLET
IDLE	IDLER
IND, L-R	INDICATOR, L-R
KEY, CONT	KEY, CONTROL
KEY, PRGM	KEY, PROGRAM
KNOB, SL	KNOB, SLIDE
LBL	LABEL
LID, BATT	LID, BATTERY
LID, CASS	LID, CASSETTE
LVR	LEVER
P-SP	P-SPRING
PANEL, CONT	PANEL, CONTORL
PANEL, FR	PANEL, FRONT
PRGM	PROGRAM
PULLY, LOAD MO	PULLY, LOADING MOTOR
RBN	RIBBON
S-	SPECIAL
SEG	SEGMENT
SH	SHEET
SHLD-SH	SHIELD-SHEET
SL	SLIDE
SP	SPRING
SP-SCREW	SPECIAL-SCREW
SPACER, BAT	SPACER, BATTERY
SPR	SPRING
SPR-P	P-SPRING
SPR-PC-PUSH	P-SPRING, C-PUSH
T-SP	T-SPRING
TERM	TERMINAL
TRIG	TRIGGER
TUN	TUNING
VOL	VOLUME
W	WASHER
WHL	WHEEL
WORM-WHL	WORM-WHEEL
ジクアム	ARM, SHAFT
ジクガイド	GUIDE, SHAFT
ストラップ	STRAP
トクナベ	S-SCRW
ヒンジ	HINGE
ヒンジビス	S-SCRW
ビスネー	SCRW, SERRART

912162

アイワ株式会社
AIWA CO., LTD.

Tokyo Japan