

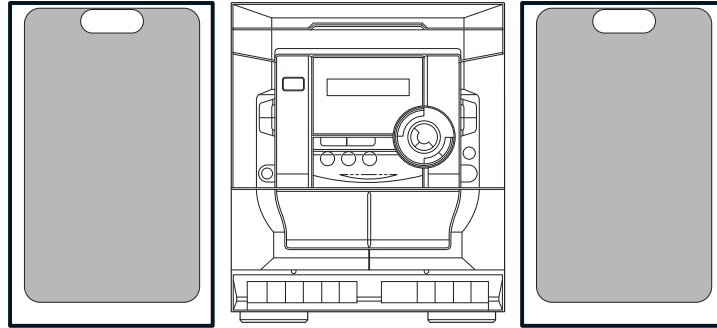

NSX-SZ103 K

NSX-SZ107 EZ



SERVICE MANUAL

COMPACT DISC
STEREO SYSTEM

BASIC TAPE MECHANISM : ZZM-2 PR1NC
BASIC CD MECHANISM : BZG-2 ZD4NC
BZG-2 ZD4N

SYSTEM	CD CASSEIVER	CD MECHANISM	SPEAKER	REMOTE CONTROLLER
NSX-SZ103	CX-NSZ103	BZG-2 ZD4NC	SX-NSZ102	RC-AAS11
NSX-SZ107	CX-NSZ107	BZG-2 ZD4N	SX-NSZ107	RC-ZAS17

- This Service Manual contains information about the difference between NSX-SZ103(K)/NSX-SZ107(EZ) and NSX-SZ100(EZ). If requiring other information, see Service Manual of NSX-SZ100(EZ), (S/M Code No. 09-00C-441-4R1).
- If requiring information about the CD mechanism, see Service Manual of BZG-2, (S/M Code No. 09-00C-353-2N2)

aiwa
S/M Code No. 09-012-441-4S1

SUPPLEMENT
DATA

SPECIFICATIONS

<FM tuner section>

Tuning range 87.5 MHz to 108 MHz
Usable sensitivity (IHF) 16.8 dBf
Antenna terminal 75 ohms (unbalanced)

<MW tuner section>

Tuning range 531 kHz to 1602 kHz (9 kHz step)
 530 kHz to 1710 kHz (10 kHz step)
Usable sensitivity 350 μ V/m
Antenna Loop antenna

<LW tuner section>

Tuning range 144 kHz to 290 kHz
Usable sensitivity 1400 μ V/m
Antenna Loop antenna

<Amplifier section>

Power output EZ:
 Rated: 8 W + 8 W (6 ohms,
 T.H.D. 1 %, 1 kHz/DIN45500)
 Reference: 10 W + 10 W (6 ohms,
 T.H.D. 10 %, 1 kHz/DIN45324)
 DIN MUSIC POWER: 30 W + 30 W
 K:
 Rated: 15 W + 15 W (6 ohms,
 T.H.D. 1 %, 1 kHz/DIN45500)
 Reference: 18 W + 18 W (6 ohms,
 T.H.D. 10 %, 1 kHz/DIN45324)
Total harmonic distortion EZ: 0.1 % (4 W, 1 kHz, 6 ohms, DIN
 AUDIO)
 K: 0.1 % (7.5 W, 1 kHz, 6 ohms, DIN
 AUDIO)
Inputs VIDEO/AUX: 500 mV
Output SPEAKERS: 6 ohms or more
 PHONES: 32 ohms or more

<Cassette deck section>

Track format 4 tracks, 2 channels stereo
Frequency response 50 Hz – 8000 Hz
Recording system AC bias
Heads Deck 1: recording/playback x 1,
 erase x 1
 Deck 2: playback x 1

<Compact disc player section>

Laser Semiconductor laser ($\lambda = 780$ nm)
D/A converter 1 bit dual
Signal-to-noise ratio 85 dB (1 kHz, 0 dB)
Harmonic distortion 0.05 % (1 kHz, 0 dB)

<Speaker system SX-NSZ102/SX-NSZ107>

Speaker system 1 way, bass reflex (magnetic shielded)
Speaker units Full range: 100 mm cone
Impedance 6 ohms
Dimensions (W x H x D) 196 x 301 x 188 mm
Weight 1.5 kg

<General>

Power requirements EZ: 230 V AC, 50 Hz
 K: 230 –240 VAC, 50 Hz
Power consumption EZ: 45 W
 K: 58 W
Dimensions (W x H x D) 260 x 301 x 292 mm
Weight EZ: 4.3 kg
 K: 4.5 kg

• Design and specifications are subject to change without notice.

ELECTRICAL MAIN PARTS LIST

REF. NO.	PART NO.	KANRI NO.	DESCRIPTION	REF. NO.	PART NO.	KANRI NO.	DESCRIPTION
IC				C51	87-010-247-080		CAP, E 100-50 SME<K>
	87-A21-893-040		C-IC, NJM14558V-TE2	C51	87-A12-095-080		CAP, E 100-50 SMG<EZ>
	87-A21-419-040		C-IC, NJM14558MD-TE2	C60	87-010-403-080		CAP, E 3.3-50 SME<K>
	8B-NFC-602-030		C-IC, UPD780226GF-023-3BA	C60	87-A12-089-080		CAP, E 3.3-50 SMG<EZ>
	87-A21-218-010		IC, NJL64H380A	C61	87-010-260-080		CAP, E 47-25 SME<K>
	87-A21-443-040		C-IC, M62495AFP	C61	87-A12-071-080		CAP, E 47-25 SMG<EZ>
	87-A21-695-010		IC, LA1845L	C74	87-010-759-080		C-CAP, U, 0.1-25F
	87-A21-928-010		IC, LC72131D-N	C101	87-012-284-080		CAP, U 6800P-50
				C102	87-012-284-080		CAP, U 6800P-50
				C103	87-010-544-080		CAP, E 0.1-50 SME<K>
TRANSISTOR				C103	87-A12-083-080		CAP, E 0.1-50 SMG<EZ>
	87-A30-494-080		TR, 2SA1980G	C104	87-010-544-080		CAP, E 0.1-50 SME<K>
	87-A30-476-010		TR, KTA1046Y	C104	87-A12-083-080		CAP, E 0.1-50 SMG<EZ>
	87-A30-492-080		TR, 2SC5343G<K>	C105	87-012-282-080		CAP, U 4700P-50
	87-A30-076-080		C-TR, 2SC3052F	C106	87-012-282-080		CAP, U 4700P-50
	87-A30-075-080		C-TR, 2SA1235F	C107	87-010-403-080		CAP, E 3.3-50 SME<K>
	87-A30-256-010		TR, 2SD1933	C107	87-A12-089-080		CAP, E 3.3-50 SMG<EZ>
	87-A30-255-010		TR, 2SB1342	C108	87-010-403-080		CAP, E 3.3-50 SME<K>
	87-A30-234-080		TR, CSC4115BC	C108	87-A12-089-080		CAP, E 3.3-50 SMG<EZ>
	87-A30-091-080		FET, 2SJ460	C109	87-012-195-080		C-CAP, U 100P-50CH
	87-A30-090-080		FET, 2SK2541	C110	87-012-195-080		C-CAP, U 100P-50CH
	87-A30-062-080		C-TR, KRC104S	C111	87-010-406-080		CAP, E 22-50 SME<K>
	87-A30-495-080		TR, 2SA1981Y	C111	87-A10-092-080		CAP, E 22-50 SMG<EZ>
	89-327-143-080		C-TR, 2SC2714 (0.1W)	C112	87-010-406-080		CAP, E 22-50 SME<K>
	87-A30-489-080		C-TR, KRA107S	C112	87-A10-092-080		CAP, E 22-50 SMG<EZ>
	89-503-602-080		C-FET, 2SK360E	C113	87-012-199-080		C-CAP, U 220P-50CH<EZ>
	87-A30-086-040		C-TR, CSD1306E	C113	87-A10-946-080		C-CAP, U 220P-100<K>
	87-A30-484-080		C-TR, KRA102S	C114	87-A10-946-080		C-CAP, U 220P-100<K>
	87-026-610-080		TR, KTC3198GR<EZ>	C114	87-012-199-080		C-CAP, U 220P-50CH<EZ>
	87-A30-615-080		TR, STC250<EZ>	C117	87-012-286-080		CAP, U 0.01-25
				C118	87-012-286-080		CAP, U 0.01-25
				C119	87-012-286-080		CAP, U 0.01-25
DIODE				C120	87-012-286-080		CAP, U 0.01-25
	87-A40-455-090		DIODE, RL203 GW	C123	87-012-280-080		CAP, U 3300-50 KB
	87-A40-553-080		DIODE, 1N4003 LES	C124	87-012-280-080		CAP, U 3300-50 KB
	87-A40-777-080		ZENER, UZ30BSB	C125	87-010-759-080		C-CAP, U, 0.1-25F
	87-A40-291-080		DIODE, 1N4148 (CPT)	C126	87-010-759-080		C-CAP, U, 0.1-25F
	87-A40-764-080		ZENER, UZ10BSC	C127	87-010-759-080		C-CAP, U, 0.1-25F
	87-A40-269-080		C-DIODE, MC2836	C128	87-010-759-080		C-CAP, U, 0.1-25F
	87-A40-270-080		C-DIODE, MC2838	C129	87-012-276-080		CAP, CHIP SS 1500 PBK
	87-A40-749-080		ZENER, UZ5.6BSB	C130	87-012-276-080		CAP, CHIP SS 1500 PBK
	87-A40-739-080		ZENER, UZ2.7BSA	C140	86-ZA1-616-080		C-CAP, U 0.01-50 K B (MUR)
	87-017-149-080		ZENER, HZS6A2L	C401	87-010-759-080		C-CAP, U, 0.1-25F
	87-A40-760-080		ZENER, UZ9.1BSA	C402	87-010-759-080		C-CAP, U, 0.1-25F
				C403	87-012-193-080		C-CAP, U 82P-50 CH
MAIN C.B				C404	87-012-193-080		C-CAP, U 82P-50 CH
	C9	87-010-759-080	C-CAP, U, 0.1-25F	C405	87-012-286-080		CAP, U 0.01-25
	C10	87-010-759-080	C-CAP, U, 0.1-25F	C406	87-012-286-080		CAP, U 0.01-25
	C11	87-010-759-080	C-CAP, U, 0.1-25F	C407	87-012-286-080		CAP, U 0.01-25
	C12	87-010-759-080	C-CAP, U, 0.1-25F	C408	87-012-286-080		CAP, U 0.01-25
	C21	87-A12-442-000	CAP, E 3300-25 M 85 IV LELON<EZ>	C409	87-012-278-080		C-CAP, U 2200P-50 B
	C21	87-A12-440-000	CAP, E 3300-35 M 85 IV LELON<K>	C410	87-012-278-080		C-CAP, U 2200P-50 B
	C22	87-A10-831-080	CAP, E 1000-25 M SMG<EZ>	C411	87-010-405-080		CAP, E 10-50 SME<K>
	C22	87-A12-441-000	CAP, E 2200-35 M 85 IV LELON<K>	C411	87-A12-091-080		CAP, E 10-50 SMG<EZ>
	C25	87-010-407-080	CAP, E 33-50 SME<K>	C412	87-010-405-080		CAP, E 10-50 SME<K>
	C25	87-A12-094-080	CAP, E 47-50 SMG<EZ>	C412	87-A12-091-080		CAP, E 10-50 SMG<EZ>
	C26	87-010-407-080	CAP, E 33-50 SME<K>	C413	87-012-286-080		CAP, U 0.01-25
	C26	87-A12-094-080	CAP, E 47-50 SMG<EZ>	C421	87-012-275-080		C-CAP, U 1200P-50 B
	C31	87-010-759-080	C-CAP, U, 0.1-25F	C422	87-012-275-080		C-CAP, U 1200P-50 B
	C32	87-012-286-080	CAP, U 0.01-25	C423	87-012-274-080		CHIP CAP, U 1000P-50B
	C34	87-010-260-080	CAP, E 47-25 SME<K>	C424	87-012-274-080		CHIP CAP, U 1000P-50B
	C34	87-A12-071-080	CAP, E 47-25 SMG<EZ>	C425	87-010-263-080		CAP, E 100-10 SME<K>
	C35	87-A10-092-080	CAP, E 22-50 SMG<EZ>	C425	87-A12-062-080		CAP, E 100-10 SMG<EZ>
	C35	87-010-406-080	CAP, E 22-50 SME<K>	C426	87-A12-062-080		CAP, E 100-10 SMG<EZ>
	C36	87-010-112-080	CAP, E 100-16 SME<K>	C426	87-010-263-080		CAP, E 100-10 SME<K>
	C36	87-A10-918-080	CAP, E 100-16 SMG<EZ>	C427	87-012-188-080		C-CAP, U 47P-50 CH
	C50	87-010-247-080	CAP, E 100-50 SME<K>	C428	87-012-188-080		C-CAP, U 47P-50 CH
	C50	87-A12-095-080	CAP, E 100-50 SMG<EZ>	C429	87-010-956-080		CHIP-CAP, S 0.068-25B
				C430	87-010-956-080		CHIP-CAP, S 0.068-25B
				C431	87-012-284-080		CAP, U 6800P-50

REF. NO.	PART NO.	KANRI NO.	DESCRIPTION	REF. NO.	PART NO.	KANRI NO.	DESCRIPTION
C432	87-012-284-080		CAP, U 6800P-50	C796	87-012-286-080		CAP, U 0.01-25
C433	87-010-546-080		CAP,E 0.33-50 SME<K>	C797	87-010-405-080		CAP,E 10-50 SME<K>
C433	87-A12-085-080		CAP,E 0.33-50 SMG<EZ>	C797	87-A12-091-080		CAP,E 10-50 SMG<EZ>
C434	87-010-546-080		CAP,E 0.33-50 SME<K>	C798	87-012-286-080		CAP, U 0.01-25
C434	87-A12-085-080		CAP,E 0.33-50 SMG<EZ>	C799	87-010-407-080		CAP,E 33-50 SME<K>
C435	87-010-263-080		CAP,E 100-10 SME<K>	C799	87-A12-093-080		CAP,E 33-50 SMG<EZ>
C435	87-A12-062-080		CAP,E 100-10 SMG<EZ>	C800	87-010-829-080		CAP, U 0.047-16
C436	87-010-759-080		C-CAP,U, 0.1-25F	C801	87-010-403-080		CAP,E 3.3-50 SME<K>
C437	87-010-759-080		C-CAP,U, 0.1-25F	C801	87-A12-089-080		CAP,E 3.3-50 SMG<EZ>
C439	87-010-759-080		C-CAP,U, 0.1-25F	C802	87-010-829-080		CAP, U 0.047-16
C440	87-010-759-080		C-CAP,U, 0.1-25F	C803	87-010-787-080		CAP, U 0.022-25
C441	87-010-759-080		C-CAP,U, 0.1-25F	C804	87-010-263-080		CAP,E 100-10 SME<K>
C442	87-010-759-080		C-CAP,U, 0.1-25F	C804	87-A12-062-080		CAP,E 100-10 SMG<EZ>
C443	87-010-759-080		C-CAP,U, 0.1-25F	C807	87-010-400-080		CAP,E 0.47-50 SME<K>
C444	87-012-197-080		C-CAP,U 150P-50 CH	C807	87-A12-086-080		CAP,E 0.47-50 SMG<EZ>
C445	87-A10-039-080		C-CAP,U 470P-50 J CH	C808	87-A12-087-080		CAP,E 1-50 SMG<EZ>
C452	87-010-382-080		CAP,E 22-25 SME<K>	C808	87-010-401-080		CAP,E 1-50 M 11 L SME<K>
C452	87-A12-069-080		CAP,E 22-25 SMG<EZ>	C809	87-A12-087-080		CAP,E 1-50 SMG<EZ>
C453	87-012-279-080		C-CAP,U 2700P-50 B	C809	87-010-401-080		CAP,E 1-50 M 11 L SME<K>
C454	87-012-279-080		C-CAP,U 2700P-50 B	C810	87-010-759-080		C-CAP,U, 0.1-25F
C455	87-012-279-080		C-CAP,U 2700P-50 B	C814	87-012-286-080		CAP, U 0.01-25
C456	87-012-286-080		CAP, U 0.01-25	C815	87-A12-086-080		CAP,E 0.47-50 SMG<EZ>
C457	87-A12-361-080		CAP,M 5600P-100 J CP	C815	87-010-400-080		CAP,E 0.47-50 M 11 L SME<K>
C458	87-012-274-080		CHIP CAP,U 1000P-50B	C816	87-A12-086-080		CAP,E 0.47-50 SMG<EZ>
C459	87-010-175-080		CAP 560P	C816	87-010-400-080		CAP,E 0.47-50 M 11 L SME<K>
C460	87-010-759-080		C-CAP,U, 0.1-25F	C818	87-012-276-080		CAP, CHIP SS 1500 PBK
C461	87-012-158-080		C-CAP,S 390P-50 CH	C821	87-010-405-080		CAP,E 10-50 SME<K>
C462	87-012-158-080		C-CAP,S 390P-50 CH	C821	87-A12-091-080		CAP,E 10-50 SMG<EZ>
C470	87-A10-039-080		C-CAP,U 470P-50 J CH	C823	87-012-349-080		C-CAP,S 1000P-50 CH
C605	87-012-275-080		C-CAP,U 1200P-50 B	C824	87-010-404-080		CAP,E 4.7-50 SME<K>
C606	87-012-275-080		C-CAP,U 1200P-50 B	C824	87-A12-090-080		CAP,E 4.7-50 SMG<EZ>
C609	87-010-785-080		C-CAP,U 0.015-25BK	C825	87-010-596-080		CAP, S 0.047-16
C610	87-010-785-080		C-CAP,U 0.015-25BK	C831	87-010-406-080		CAP,E 22-50 SME<K>
C611	87-010-545-080		CAP,E 0.22-50 SME<K>	C831	87-A10-092-080		CAP,E 22-50 SMG<EZ>
C611	87-A12-084-080		CAP,E 0.22-50 SMG<EZ>	C836	87-012-286-080		CAP, U 0.01-25
C612	87-010-545-080		CAP,E 0.22-50 SME<K>	C837	87-012-286-080		CAP, U 0.01-25
C612	87-A12-084-080		CAP,E 0.22-50 SMG<EZ>	C842	87-012-286-080		CAP, U 0.01-25
C613	87-010-545-080		CAP,E 0.22-50 SME<K>	C844	87-012-286-080		CAP, U 0.01-25
C613	87-A12-084-080		CAP,E 0.22-50 SMG<EZ>	C850	87-010-260-080		CAP,E 47-25 SME<K>
C614	87-010-545-080		CAP,E 0.22-50 SME<K>	C850	87-A12-071-080		CAP,E 47-25 SMG<EZ>
C614	87-A12-084-080		CAP,E 0.22-50 SMG<EZ>	C851	87-012-286-080		CAP, U 0.01-25
C615	87-012-172-080		CAPACITOR CHIP U 10P CH	C852	87-012-286-080		CAP, U 0.01-25
C616	87-010-248-080		CAP,E 220-10 SME<K>	C853	87-012-286-080		CAP, U 0.01-25
C616	87-A12-063-080		CAP,E 220-10 SMG<EZ>	C858	87-010-759-080		C-CAP,U, 0.1-25F
C617	87-010-221-080		CAP,E 470-10 SME<K>	C859	87-010-759-080		C-CAP,U, 0.1-25F
C617	87-016-459-040		CAP,E 470-10 SMG<EZ>	C860	87-012-286-080		CAP, U 0.01-25
C618	87-010-405-080		CAP,E 10-50 SME<K>	C942	87-012-167-080		C-CAP,U 5P-50 CH
C618	87-A12-091-080		CAP,E 10-50 SMG<EZ>	C947	87-012-286-080		CAP, U 0.01-25
C630	87-A10-260-080		C-CAP,U 0.1-16 K B	C948	87-A10-039-080		C-CAP,U 470P-50 J CH
C669	87-012-195-080		C-CAP,U 100P-50CH	C952	87-012-286-080		CAP, U 0.01-25
C670	87-012-195-080		C-CAP,U 100P-50CH	C957	87-012-174-080		CAP CHIP CERA SS 12P CHJ
C771	87-010-263-080		CAP,E 100-10 SME<K>	C958	87-012-286-080		CAP, U 0.01-25
C771	87-A12-062-080		CAP,E 100-10 SMG<EZ>	C962	87-010-401-080		CAP,E 1-50 SME<K>
C772	87-012-286-080		CAP, U 0.01-25	C962	87-A12-087-080		CAP,E 1-50 SMG<EZ>
C779	87-010-971-080		C-CAP,S 4700P-50 B J	C971	87-010-381-080		CAP,E 330-16 SME<K>
C780	87-010-971-080		C-CAP,S 4700P-50 B J	C971	87-A12-067-080		CAP,E 330-16 SMG<EZ>
C782	87-012-286-080		CAP, U 0.01-25	C972	87-010-404-080		CAP,E 4.7-50 SME<K>
C783	87-012-286-080		CAP, U 0.01-25	C972	87-A12-090-080		CAP,E 4.7-50 SMG<EZ>
C784	87-012-286-080		CAP, U 0.01-25	C973	87-012-286-080		CAP, U 0.01-25
C785	87-012-286-080		CAP, U 0.01-25	C974	87-012-286-080		CAP, U 0.01-25
C786	87-012-286-080		CAP, U 0.01-25	C979	87-012-195-080		C-CAP,U 100P-50CH
C788	87-012-167-080		C-CAP,U 5P-50 CH	C981	87-010-260-080		CAP,E 47-25 SME<K>
C789	87-A10-801-080		C-CAP,S 0.022-16 J B CM	C981	87-A12-071-080		CAP,E 47-25 SMG<EZ>
C790	87-A10-801-080		C-CAP,S 0.022-16 J B CM	C982	87-010-759-080		C-CAP,U, 0.1-25F
C791	87-010-759-080		C-CAP,U, 0.1-25F	C983	87-012-286-080		CAP, U 0.01-25
C792	87-012-286-080		CAP, U 0.01-25	C984	87-012-286-080		CAP, U 0.01-25
C793	87-010-404-080		CAP,E 4.7-50 SME<K>	C985	87-012-195-080		C-CAP,U 100P-50CH
C793	87-A12-090-080		CAP,E 4.7-50 SMG<EZ>	C987	87-012-286-080		CAP, U 0.01-25
C794	87-A10-039-080		C-CAP,U 470P-50 J CH	C989	87-012-286-080		CAP, U 0.01-25
C795	87-012-286-080		CAP, U 0.01-25	C990	87-012-195-080		C-CAP,U 100P-50CH

REF. NO.	PART NO.	KANRI NO.	DESCRIPTION	REF. NO.	PART NO.	KANRI NO.	DESCRIPTION
C991	87-012-176-080		CAP 15P	C524	87-010-787-080		CAP, U 0.022-25
C992	87-012-176-080		CAP 15P	C525	87-010-071-040		CAP,E 1-50 M 5L SRE
C993	87-012-274-080		CHIP CAP,U 1000P-50B	C526	87-010-405-040		CAP,E 10-50
C994	87-012-195-080		C-CAP,U 100P-50CH	C527	87-A10-039-080		C-CAP,U 470P-50 J CH
C995	87-012-274-080		CHIP CAP,U 1000P-50B	C528	87-010-263-040		CAP,E 100-10 M 11L SME
C996	87-012-195-080		C-CAP,U 100P-50CH	C530	87-012-195-080		C-CAP,U 100P-50CH
C997	87-010-759-080		C-CAP,U, 0.1-25F	C531	87-012-195-080		C-CAP,U 100P-50CH
C998	87-010-260-080		CAP,E 47-25 SME<K>	C532	87-012-195-080		C-CAP,U 100P-50CH
C998	87-A12-071-080		CAP,E 47-25 SMG<EZ>	C533	87-012-195-080		C-CAP,U 100P-50CH
C999	87-A11-155-080		CAP,TC U 0.01-16 Z F	C534	87-012-195-080		C-CAP,U 100P-50CH
CF831	87-008-423-010		CERAMIC FILTER, SFE10.7	C535	87-012-195-080		C-CAP,U 100P-50CH
CF832	82-785-747-010		CF MS2 GHY R	C536	87-012-195-080		C-CAP,U 100P-50CH
CN351	87-A60-625-010		CONN,8P V 2MM JMT	C537	87-012-195-080		C-CAP,U 100P-50CH
CN401	87-A60-620-010		CONN,3P V 2MM JMT	C538	87-012-195-080		C-CAP,U 100P-50CH
CN602	87-099-194-010		CONN,6P 6216V	C539	87-012-195-080		C-CAP,U 100P-50CH
CNA351	8B-NFC-634-010		CONN ASSY,8P RPB	C540	87-010-759-080		C-CAP,U, 0.1-25F
CNA401	8B-NFC-633-010		CONN ASSY,3P (PH)	C546	87-010-759-080		C-CAP,U, 0.1-25F
△ F101	87-A91-207-010		FUSE 315MA 250VT 50T<EZ>	C555	87-012-172-080		CAP 10P-50
△ FC101	87-033-213-080		FUSE CLAMP,PFC5000<EZ>	C556	87-012-198-080		CAP 180P
△ FC102	87-033-213-080		FUSE CLAMP,PFC5000<EZ>	C557	87-010-831-080		C-CAP,U,0.1-16F
FC602	88-906-251-110		FF-CABLE,6P 1.25	C558	87-010-831-080		C-CAP,U,0.1-16F
FFE831	A8-6ZA-199-170		6ZA-1 FEENC<K>	C560	87-012-286-080		CAP, U 0.01-25
FFE831	A8-6ZA-19C-170		6ZA-1 YFEENC<EZ>	CN501	87-A60-673-010		CONN,9P H 2MM JMT
J101	87-A61-480-010		JACK,DIA6.3 BLK ST W/SW MSC16A	CN502	87-099-196-010		CONN,8P 6216 V
J103	87-A61-452-010		TERMINAL,SP 4P(MSC)	FC502	88-908-201-110		FF-CABLE,8P 1.25
J602	87-A60-881-010		JACK,PIN 2P MSP 242V05 PBSN	FL501	8B-NFC-601-010		FL,NHA-10SS18T
J832	87-A60-403-010		TERMINAL,ANT PAL 2P HSP-312V05	L501	87-A50-655-010		COIL,CLK 4.19MHZ (TOKO) 7KLY
JR621	87-010-598-080		C-CAP,S 0.068-16	S301	87-A91-024-180		SW,TACT KSH0611BT
JR622	87-010-598-080		C-CAP,S 0.068-16	S302	87-A91-024-180		SW,TACT KSH0611BT
△ JW001	87-A91-941-080		PROTECTOR,3A 20P 60V<K>	S303	87-A91-024-180		SW,TACT KSH0611BT
△ JW002	87-A91-941-080		PROTECTOR,3A 20P 60V<K>	S304	87-A91-024-180		SW,TACT KSH0611BT
JW959	87-A11-155-080		CAP,TC U 0.01-16 Z F	S305	87-A91-024-180		SW,TACT KSH0611BT
L101	87-A50-611-010		COIL,1UH K(CS)	S306	87-A91-024-180		SW,TACT KSH0611BT
L102	87-A50-611-010		COIL,1UH K(CS)	S307	87-A91-024-180		SW,TACT KSH0611BT
L451	87-007-342-010		COIL,OSC 85K BIAS	S308	87-A91-024-180		SW,TACT KSH0611BT
L801	87-A50-608-010		COIL,FM DET-N(TOK)	S309	87-A91-024-180		SW,TACT KSH0611BT
L802	87-A91-551-010		FLTR,PCFJZH-450 L(TOK)	S310	87-A91-024-180		SW,TACT KSH0611BT
L811	87-005-847-080		COIL,2.2UH(CECS)	S311	87-A91-024-180		SW,TACT KSH0611BT
L832	87-005-847-080		COIL,2.2UH(CECS)	S312	87-A91-024-180		SW,TACT KSH0611BT
L941	87-A50-020-010		COIL,ANT LW(COI)	S313	87-A91-024-180		SW,TACT KSH0611BT
L942	87-A50-019-010		COIL,OSC LW(COI)	S314	87-A91-024-180		SW,TACT KSH0611BT
△ L951	8A-NF8-668-010		COIL,AM PACK 2(TOK)	S315	87-A91-024-180		SW,TACT KSH0611BT
△ PT101	8B-NFC-608-010		PT,BNF-C EZ<EZ>	S316	87-A91-024-180		SW,TACT KSH0611BT
△ PT101	8B-NFC-610-010		PT,BNF-C K<K>	SFR391	87-024-431-080		SFR,3.3K RH063EC
R790	87-012-286-080		CAP, U 0.01-25				
RY101	87-A91-339-010		RELAY,AC DC12V G5PA-2				
T101	87-A60-317-010		TERMINAL, 1P MSC				
T102	87-A60-317-010		TERMINAL, 1P MSC				
TC942	87-A91-774-080		TRIMMER,PLY 30P 6.8X5.4 CDYL				
X992	87-A70-306-010		VIB,XTAL 4.500MHZ CSA-309ST				

FRONT C.B

C390	87-010-384-040		CAP,E 100-25 SME
C500	87-010-759-080		C-CAP,U, 0.1-25F
C505	87-010-829-080		CAP, U 0.047-16
C506	87-010-263-040		CAP,E 100-10
C507	87-010-246-040		CAP,E 47-35 SME<K>
C507	87-A12-078-040		CAP,E 47-35 SMG<EZ>
C508	87-010-192-080		C-CAP,S 0.022-50 F
C509	87-010-404-040		CAP,E 4.7-50 SME
C510	87-010-404-040		CAP,E 4.7-50 SME
C516	87-010-831-080		C-CAP,U,0.1-16F
C517	87-010-831-080		C-CAP,U,0.1-16F
C518	87-012-274-080		CHIP CAP,U 1000P-50B
C519	87-012-336-080		CAP, CHIP SS 3300 SL
C520	87-012-282-080		CAP, U 4700P-50
C521	87-010-829-080		CAP, U 0.047-16
C522	87-016-459-040		CAP,E 470-10 SMG
C523	87-010-248-040		CAP,E 220-10 SME

○チップ抵抗部品コード／CHIP RESISTOR PART CODE

チップ抵抗部品コードの成り立ち

Chip Resistor Part Coding

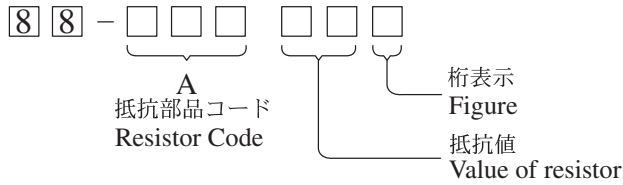

チップ抵抗
Chip resistor

容量 Wattage	種類 Type	許容誤差 Tolerance	記号 Symbol	寸法/Dimensions (mm)			抵抗コード : A Resistor Code : A	
				外形/Form	L	W		t
1/16W	1005	± 5%	CJ		1.0	0.5	0.35	104
1/16W	1608	± 5%	CJ		1.6	0.8	0.45	108
1/10W	2125	± 5%	CJ		2	1.25	0.45	118
1/8W	3216	± 5%	CJ		3.2	1.6	0.55	128

TRANSISTOR ILLUSTRATION

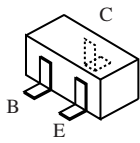

2SA1235F
2SC2714
2SC3052F
CSD1306E
KRA102S
KRA107S
KRC104S



E C B

2SA1980G
2SA1981Y
2SC5343G
STC250



E C B

CSC4115BC
KTC3198GR



B C E

2SD1933
2SB1342
KTA1046Y

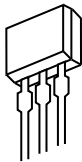

S D G

2SK2541
2SJ460

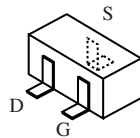

2SK360E

A B C D E F G H I J K L M N O P Q R S T U

1 2 3 4 5 6 7 8 9 10 11 12 13 14 15 16 17 18 19 20 21 22 23 24 25 26 27 28 29 30 31 32

B FRONT C.B

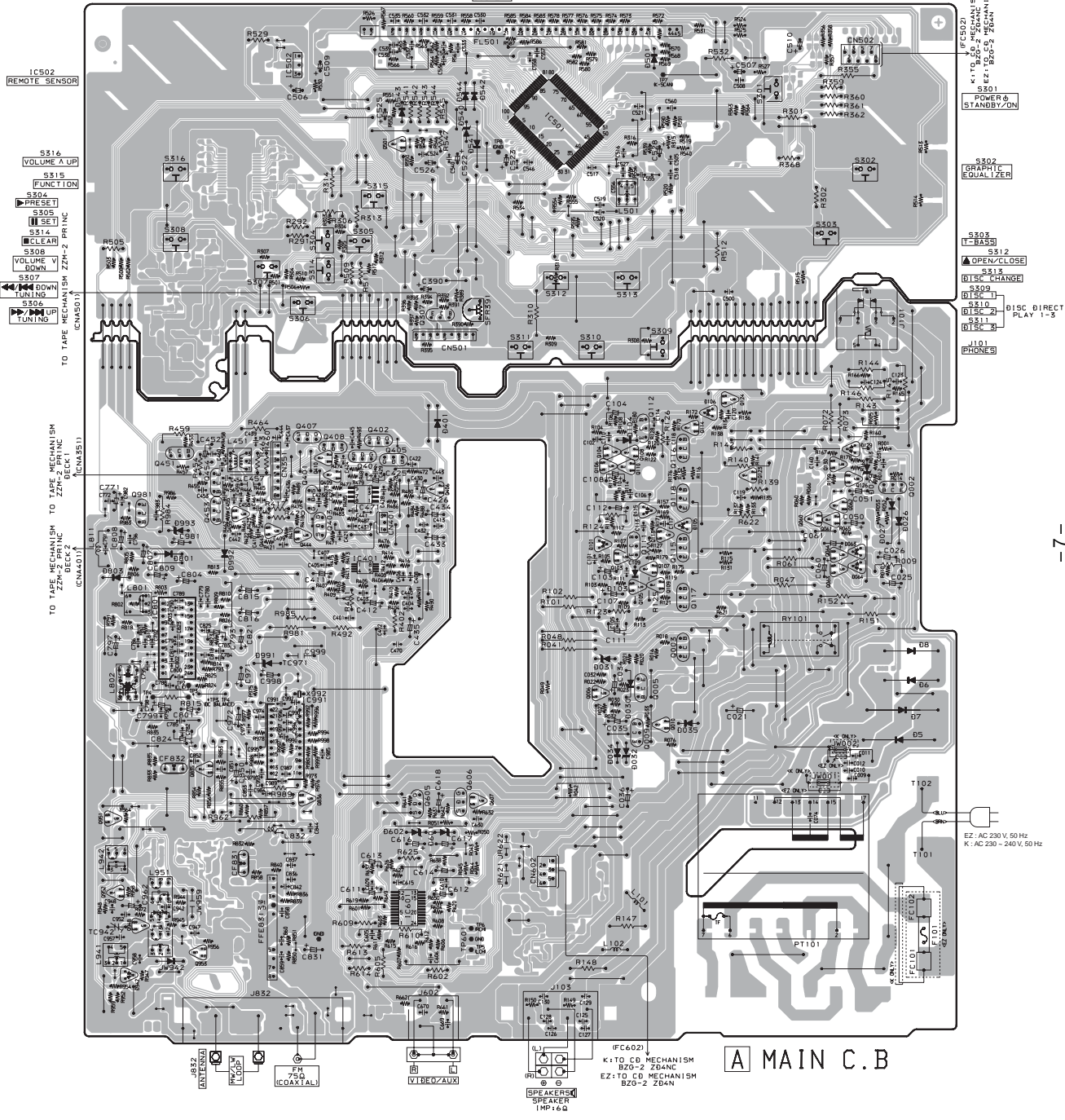

A MAIN C.B

WIRING (MAIN / FRONT)

SCHEMATIC DIAGRAM - 1 (MAIN 1/2: AMP SECTION)

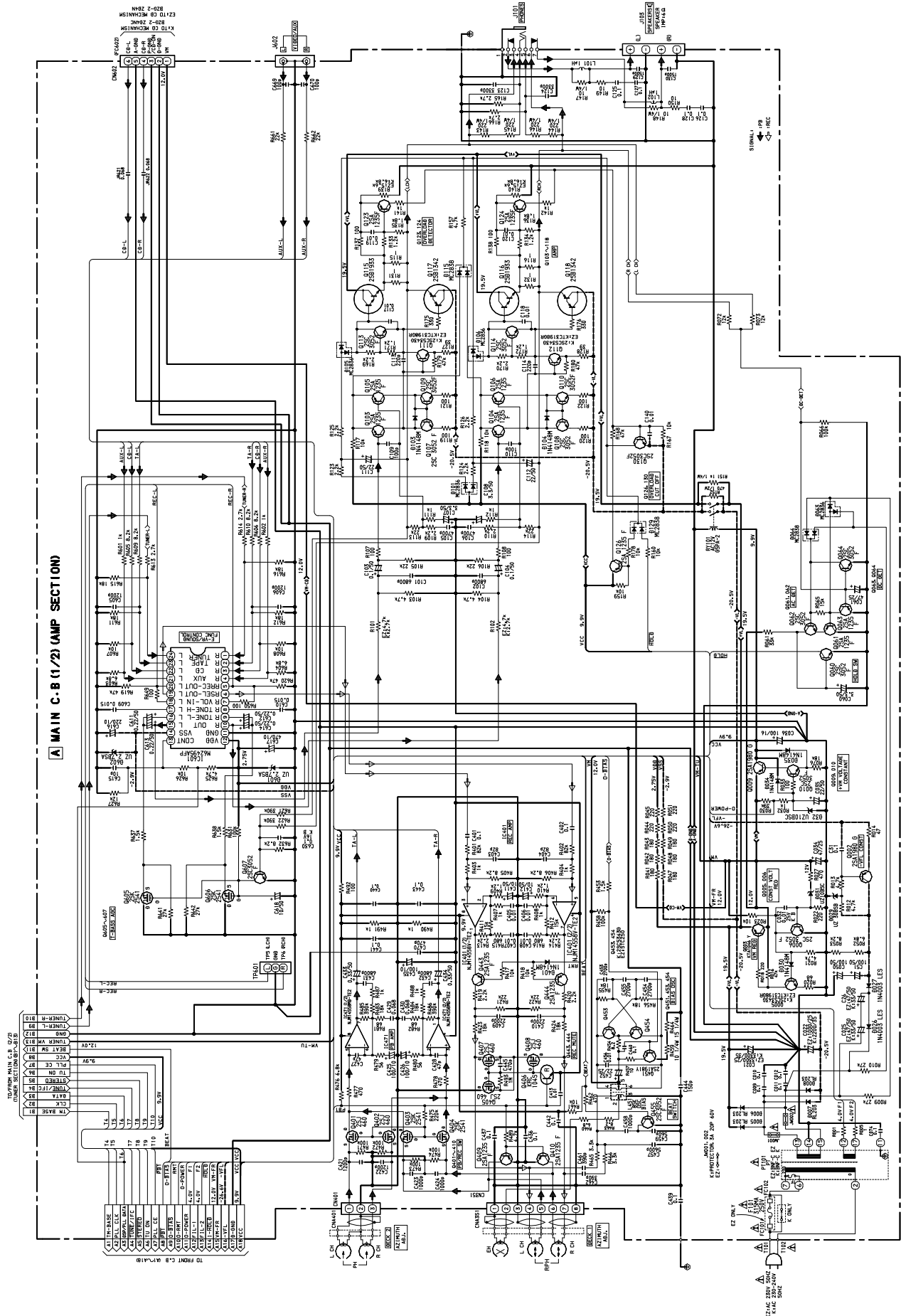

SCHEMATIC DIAGRAM - 2 (MAIN 2/2: TUNER SECTION)

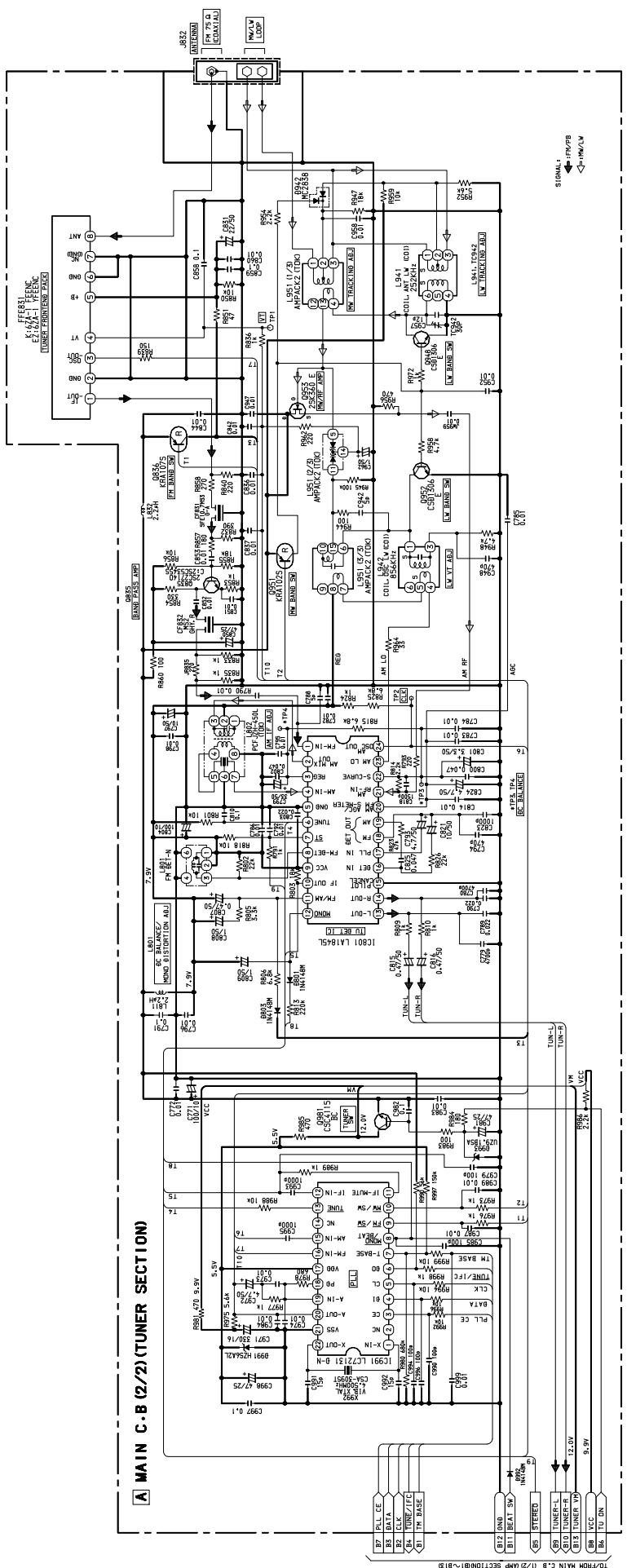

10-FROM MAIN C.B. (1/2) AMP SECT100B1 ~ B13

SCHEMATIC DIAGRAM - 3 (FRONT)

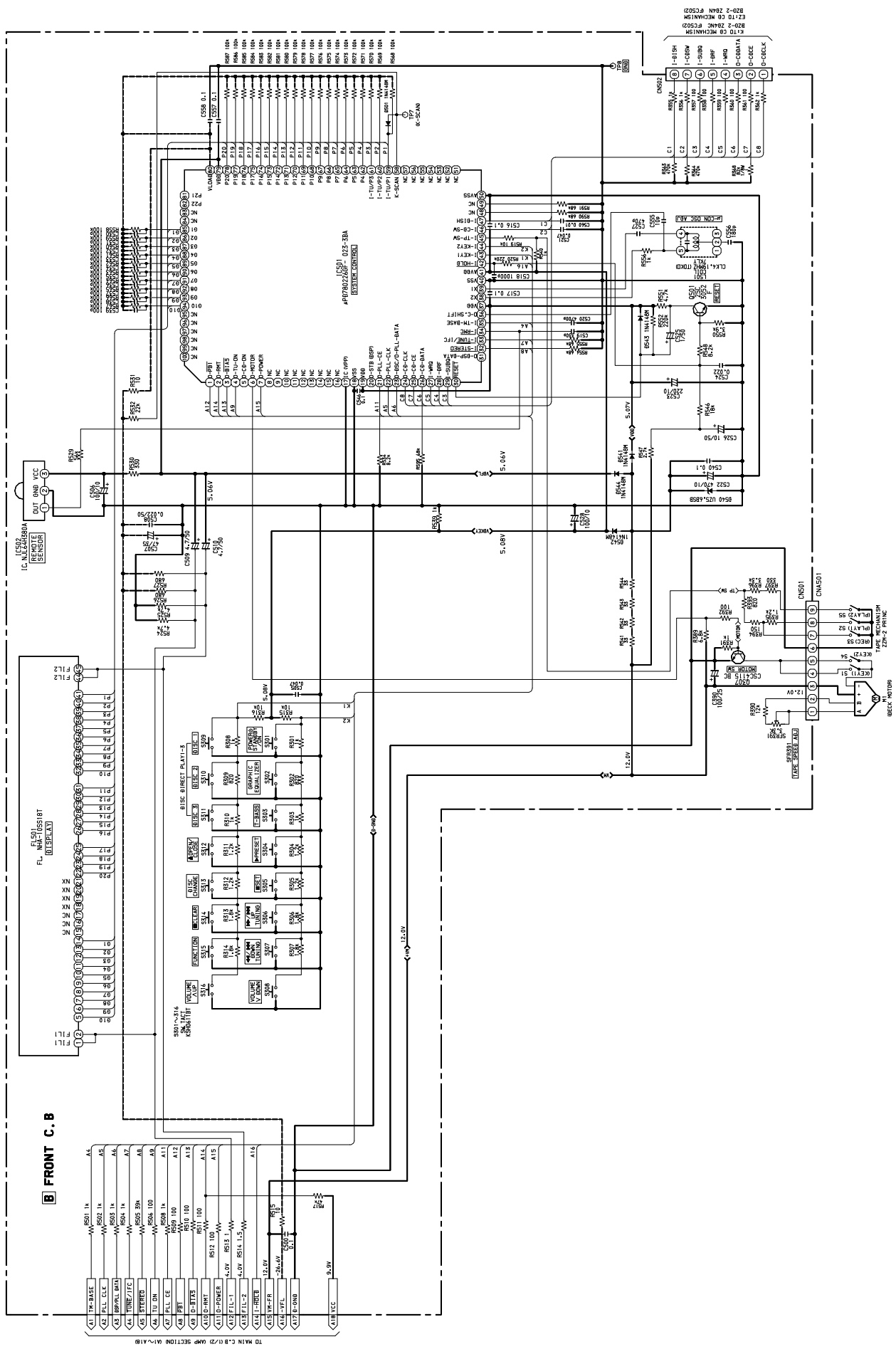

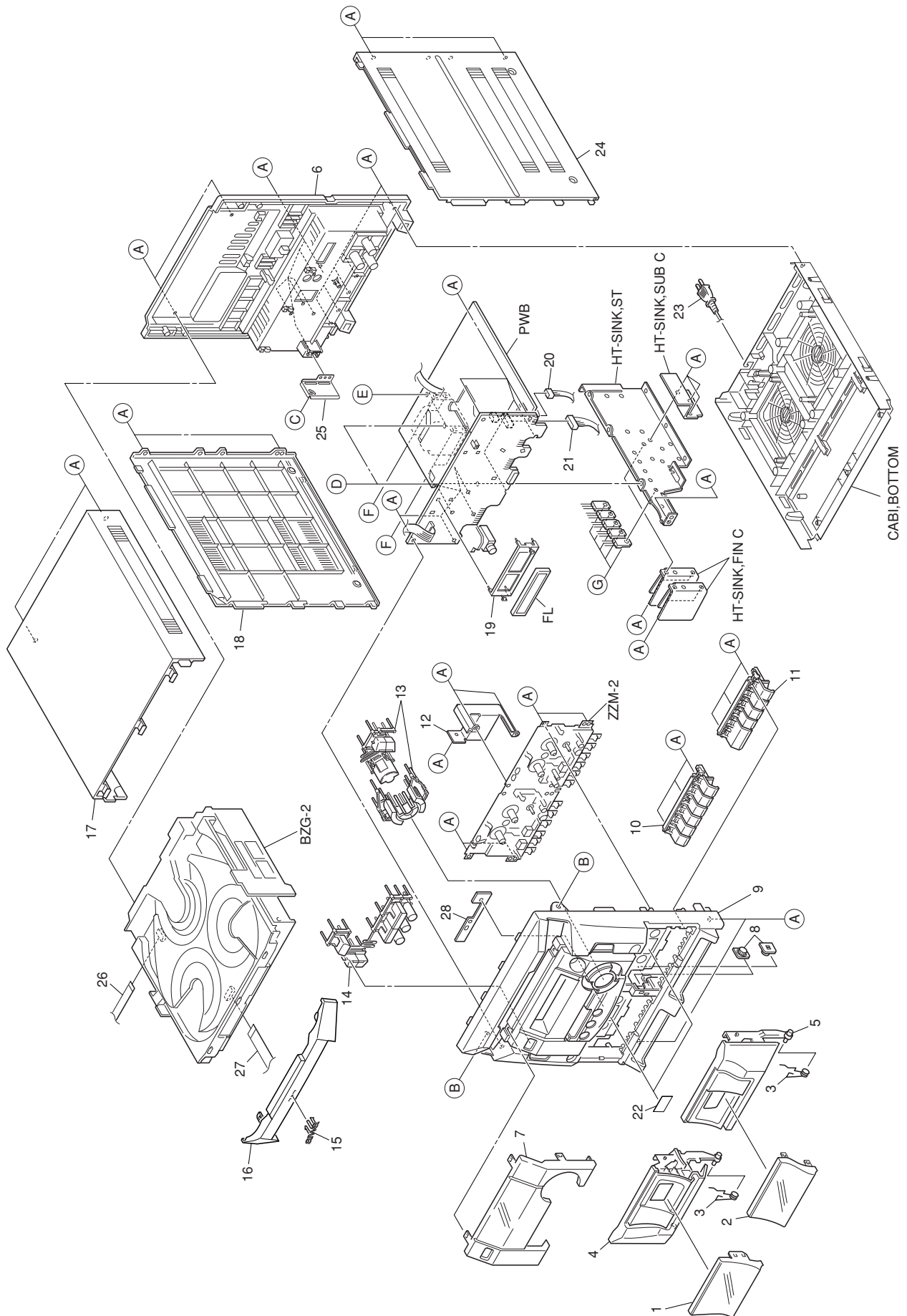

MECHANICAL PARTS LIST 1 / 1 <EZ>

REF. NO.	PART NO.	KANRI NO.	DESCRIPTION
1	8B-NFC-048-010		WINDOW, CASS 1 BLK
2	8B-NFC-049-010		WINDOW, CASS 2 BLK
3	82-NF7-218-010		SPR-T, CASS
4	8B-NFC-043-010		BOX, CASS 1 BLK
5	8B-NFC-044-010		BOX, CASS 2 BLK
6	8B-NFC-086-210		CABI, REAR EZB
7	8B-NFC-047-010		WINDOW, DISP EZ SZ107
8	8A-NFA-231-010		OIL-DMPR, 70
9	8B-NFC-041-010		CABI, FR EZ BLK
10	8B-NFC-050-110		KEY, CASS 1 BLK
11	8B-NFC-051-110		KEY, CASS 2 BLK
12	8A-NEC-206-010		HLDR, DECK
13	8B-NFC-053-010		KEY, PLAY BLK
14	8B-NFC-052-010		KEY, POWER BLK
15	87-CE3-023-010		BADGE, AIWA 30N SILV
16	8B-NFC-042-010		PANEL, TRAY BLK
17	8B-NFA-093-010		PANEL, TOP BLK
18	8B-NFC-045-010		PANEL, LEFT BLK
19	8A-NFA-208-010		GUIDE, FL 100-25 ANFA
20	8B-NFC-633-010		CONN ASSY, 3P (PH)
21	8B-NFC-634-010		CONN ASSY, 8P RPB
22	81-532-080-010		LABEL, CASS. COMPT
△ 23	87-A80-092-010		AC CORD ASSY, E BLK SUN FAI
24	8B-NFC-046-010		PANEL, RIGHT BLK
25	8A-NEC-201-110		HLDR, PT
26	88-906-251-110		FF-CABLE, 6P 1.25 (RVS-FACE)
27	88-908-201-110		FF-CABLE, 8P 1.25
28	8B-NFC-643-010		PWB HLDR WIRE
A	87-067-703-010		TAPPING SCREW, BVT2+3-10
B	87-721-096-410		QT2+3-10 GLD
C	87-571-092-410		TAPPING SCREW, VIT+3-4
D	87-067-579-010		TAPPING SCREW, BVT2+3-8
E	87-NF4-224-010		S-SCREW, IT3B+3-8 CU
F	87-067-975-010		S-SCREW, IT+4-8
G	87-067-001-010		S-SCREW, BVWST2+3-12 W/O SLOT

COLOR NAME TABLE

Basic color symbol	Color	Basic color symbol	Color	Basic color symbol	Color
B	Black	C	Cream	D	Orange
G	Green	H	Gray	L	Blue
LT	Transparent Blue	N	Gold	P	Pink
R	Red	S	Silver	ST	Titan Silver
T	Brown	V	Violet	W	White
WT	Transparent White	Y	Yellow	YT	Transparent Yellow
LM	Metallic Blue	LL	Light Blue	GT	Transparent Green
LD	Dark Blue	DT	Transparent Orange	GM	Metallic Green
YM	Metallic Yellow	DM	Metallic Orange	PT	Transparent Pink
LA	Aqua Blue	GL	Light Green	HT	Transparent Gray

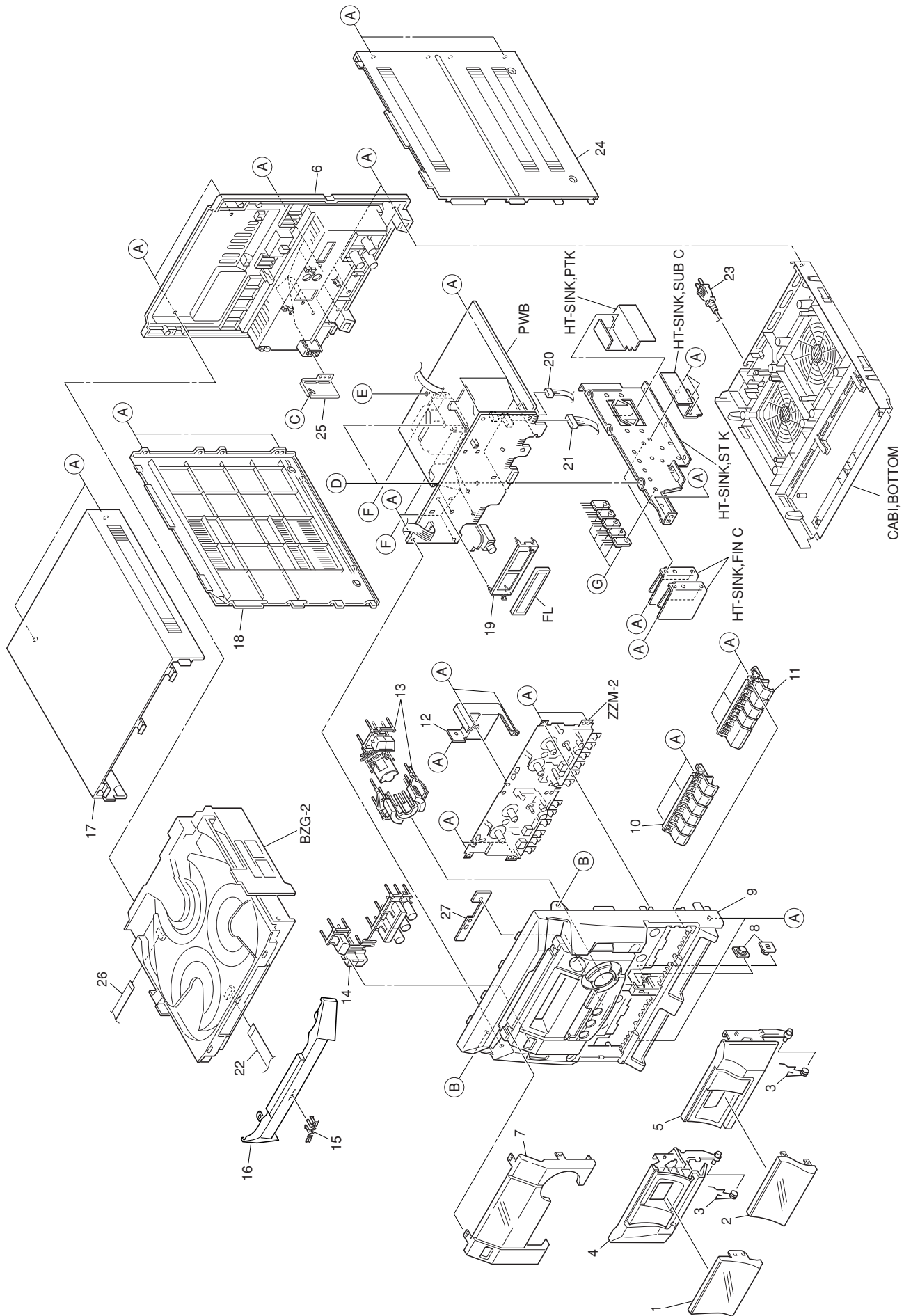

MECHANICAL PARTS LIST 1 / 1 <K>

REF. NO.	PART NO.	KANRI NO.	DESCRIPTION
1	8B-NFC-008-010		WINDOW, CASS 1
2	8B-NFC-009-010		WINDOW, CASS 2
3	82-NF7-218-010		SPR-T, CASS
4	8B-NFC-003-110		BOX, CASS 1
5	8B-NFC-004-110		BOX, CASS 2
6	8B-NFC-016-210		CABI, REAR KSC
7	8B-NFC-034-010		WINDOW, DISP K 103
8	8A-NFA-231-010		OIL-DMPR, 70
9	8B-NFC-001-010		CABI, FR U
10	8A-NED-010-210		KEY, CASS 1
11	8A-NED-011-110		KEY, CASS 2
12	8A-NEC-206-010		HLDR, DECK
13	8B-NFC-020-010		KEY, PLAY
14	8B-NFC-005-010		KEY, POWER
15	87-B00-002-010		BADGE, AIWA 30 ABS SIL
16	8B-NFC-002-010		PANEL, TRAY
17	8B-NFA-004-010		PANEL, TOP
18	8B-NFC-010-010		PANEL, LEFT
19	8A-NFA-208-010		GUIDE, FL 100-25 ANFA
20	8B-NFC-633-010		CONN ASSY, 3P (PH)
21	8B-NFC-634-010		CONN ASSY, 8P RPB
22	88-908-201-110		FF-CABLE, 8P 1.25
△	23	87-A80-157-010	AC CORD ASSY, E BLK CC
24	8B-NFC-040-010		PANEL, RIGHT K
25	8A-NEC-201-110		HLDR, PT
26	88-906-251-110		FF-CABLE, 6P 1.25 (RVS-FACE)
27	8B-NFC-643-010		PWB HLDR WIRE
A	87-067-703-010		TAPPING SCREW, BVT2+3-10
B	87-721-096-410		QT2+3-10 GLD
C	87-571-092-410		TAPPING SCREW, VIT+3-4
D	87-067-579-010		TAPPING SCREW, BVT2+3-8
E	87-NF4-224-010		S-SCREW, IT3B+3-8 CU
F	87-067-975-010		S-SCREW, IT+4-8
G	87-067-001-010		S-SCREW, BVWWST2+3-12 W/O SLOT

COLOR NAME TABLE

Basic color symbol	Color	Basic color symbol	Color	Basic color symbol	Color
B	Black	C	Cream	D	Orange
G	Green	H	Gray	L	Blue
LT	Transparent Blue	N	Gold	P	Pink
R	Red	S	Silver	ST	Titan Silver
T	Brown	V	Violet	W	White
WT	Transparent White	Y	Yellow	YT	Transparent Yellow
LM	Metallic Blue	LL	Light Blue	GT	Transparent Green
LD	Dark Blue	DT	Transparent Orange	GM	Metallic Green
YM	Metallic Yellow	DM	Metallic Orange	PT	Transparent Pink
LA	Aqua Blue	GL	Light Green	HT	Transparent Gray

SPEAKER PARTS LIST (SX-NSZ102) <YSC>

REF.NO.	PART NO.	KANRI NO.	DESCRIPTION
1	8B-NSN-001-110		GRILLE, FRAME ASSY
2	8A-NSM-008-010		CORD, SPKR
3	8A-NSM-606-010		SPKR, 100

SPEAKER PARTS LIST (SX-NSZ107) <YBC>

REF.NO.	PART NO.	KANRI NO.	DESCRIPTION
1	8B-NSN-015-010		GRILLE, FRAME ASSY B
2	8A-NSM-008-010		CORD, SPKR
3	8A-NSM-606-010		SPKR, 100

ACCESSORIES / PACKAGE LIST

REF.NO.	PART NO.	KANRI NO.	DESCRIPTION
1	8B-NFC-916-010		IB, EZ (9L) I<EZ>
1	8B-NFC-905-010		IB, K (E) S<K>
2	8Z-NF9-703-110		RC UNIT, RC-ZAS17<EZ>
2	8B-NFC-702-010		RC UNIT, RC-AAS11 (VS) <K>
3	87-006-268-010		ANT, LOOP AM



アイワ株式会社 〒110-8710 東京都台東区池之端1-2-11 ☎03(3827)3111 (代表)
AIWA CO.,LTD. 2-11, IKENOHATA 1-CHOME, TAITO-KU, TOKYO 110, JAPAN TEL:03 (3827) 3111