

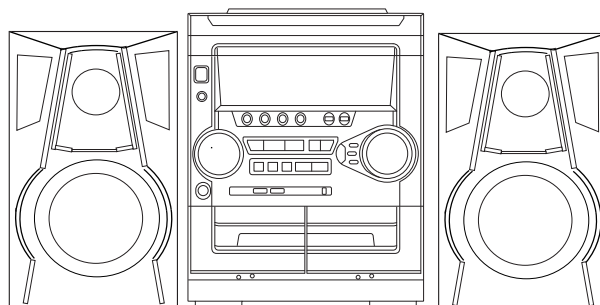

NSX-SZ20 EZ, K

NSX-SZ22 EZ

NSX-SZ27 EZ



SERVICE MANUAL

COMPACT DISC
STEREO SYSTEM

BASIC TAPE MECHANISM : ZZM-3 PR1NM / YPR1NF
BASIC CD MECHANISM : AZG-1 ZD8RDM / YZD8RDM

SYSTEM	CD CASSEIVER	SPEAKER	REMOTE CONTROLLER
NSX-SZ20	CX-NSZ20	SX-NSZ20	RC-ZAS02
NSX-SZ22	CX-NSZ22	SX-NSZ22	
NSX-SZ27	CX-NSZ27	SX-NSZ20	RC-ZAS17

SYSTEM	TAPE MECHANISM	CD MECHANISM
NSX-SZ20<EZ> NSX-SZ22<EZ> NSX-SZ27<EZ>	ZZM-3 PR1NM	AZG-1 ZD8RDM
NSX-SZ20<K>	ZZM-3 YPR1NF	AZG-1 YZD8RDM

- This Service Manual is the "Revision Publishing" and replaces "Simple Manual" NSX-SZ20/22 (EZ), (S/M Code No. 09-99C-423-4T2) and NSX-SZ27 (EZ), (S/M Code No. 09-001-423-4T3).
- If requiring information about the CD mechanism, see Service Manual of AZG-1, (S/M Code No. 09-001-335-3N6).

aiwa

S/M Code No. 09-003-423-4R2

REVISION

DATA

SPECIFICATIONS

<FM tuner section>

Tuning range 87.5 MHz to 108 MHz
Usable sensitivity (IHF) 16.8 dBf
Antenna terminals 75 ohms (unbalanced)

<MW tuner section>

Tuning range 531 kHz to 1602 kHz (9 kHz step)
 530 kHz to 1710 kHz (10 kHz step)
Usable sensitivity 350 μ V/m
Antenna Loop antenna

<LW tuner section>

Tuning range 144 kHz to 290 kHz
Usable sensitivity 1400 μ V/m
Antenna Loop antenna

<Amplifier section>

Power output Rated : 30 W + 30 W
 (6 ohms, THD 1%, 1 kHz/DIN 45500)
 Reference : 35 W + 35 W
 (6 ohms, THD 10%, 1 kHz/DIN 45324)
 DIN MUSIC POWER : 67 W + 67 W

Total harmonic distortion 0.08% (15 W, 1 kHz, 6 ohms,
 DIN AUDIO)

Inputs VIDEO/AUX: 500 mV
Outputs SPEAKERS: accept speakers of 6
 ohms or more
 PHONES (stereo jack) : accepts
 headphones of 32 ohms or more

<Cassette deck section>

Track format 4 tracks, 2 channels stereo
Frequency response 50 Hz – 15 kHz
Recording system AC bias
Heads Deck 1 : Playback head x 1
 Deck 2 : Recording/Playback head
 x 1, erase head x 1

<Compact disc player section>

Laser Semiconductor laser ($\lambda = 780$ nm)
D-A converter 1 bit dual
Signal-to-noise ratio 85 dB (1 kHz, 0 dB)
Harmonic distortion 0.05 % (1 kHz, 0 dB)

<Speaker system>

<(20EZ, 20K, 27EZ) : SX-NSZ20, (22EZ) : SX-NSZ22>
Speaker System 3 way, bass reflex (magnetic
 shielded type)
Speaker units Woofer : 140 mm cone type
 Tweeter : 60mm cone type
 Super tweeter : 20 mm ceramic type
Impedance 6 ohms
Output sound pressure level 87 dB/W/m
Dimensions (W x H x D) 230 x 324x 256 mm
Weight 3.8 kg

<General>

Power requirements 230 V AC, 50 Hz
Power consumption 80 W
Power consumption in standby mode

14 W With power-economizing
 mode off
 0.9 W With power-economizing
 mode on

**Dimensions of main unit
 (W x H x D)** 260 x 328 x 335 mm

Weight of main unit 6.2 kg <EZ>
 6.3 kg <K>

- Design and specifications are subject to change without notice.

- The word "BBE" and the "BBE symbol" are trademarks of BBE Sound, Inc.
 Under license from BBE Sound, Inc.

PROTECTION OF EYES FROM LASER BEAM DURING SERVICING

This set employs laser. Therefore, be sure to follow carefully the instructions below when servicing.

WARNING!!

WHEN SERVICING, DO NOT APPROACH THE LASER EXIT WITH THE EYE TOO CLOSELY. IN CASE IT IS NECESSARY TO CONFIRM LASER BEAM EMISSION. BE SURE TO OBSERVE FROM A DISTANCE OF MORE THAN 30cm FROM THE SURFACE OF THE OBJECTIVE LENS ON THE OPTICAL PICK-UP BLOCK.



- s Caution: Invisible laser radiation when open and interlocks defeated avoid exposure to beam.
- s Advarsel: Usynlig laserstråling ved åbning, når sikkerhedsafbrydere er ude af funktion. Undgå udsættelse for stråling.

CAUTION

Use of controls or adjustments or performance of procedures other than those specified herein may result in hazardous radiation exposure.

ATTENTION

L'utilisation de commandes, réglages ou procédures autres que ceux spécifiés peut entraîner une dangereuse exposition aux radiations.

ADVARSEL

Usynlig laserstråling ved åbning, når sikkerhedsafbrydere er ude af funktion. Undgå udsættelse for stråling.

This Compact Disc player is classified as a CLASS 1 LASER product.

The CLASS 1 LASER PRODUCT label is located on the rear exterior.

VAROITUS!

Laiteen Käyttäminen muulla kuin tässä käyttöohjeessa mainitulla tavalla saattaa altistaa käyttäjän turvallisuusluokan 1 ylittävälle näkymättömälle lasersäteilylle.

WARNING!

Om apparaten används på annat sätt än vad som specificeras i denna bruksanvisning, kan användaren utsättas för osynlig laserstrålning, som överskrider gränsen för laserklass 1.

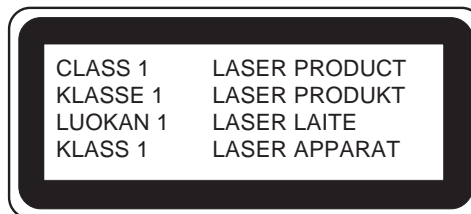

Precaution to replace Optical block (KSM-880CAB)

Body or clothes electrostatic potential could ruin laser diode in the optical block. Be sure ground body and workbench, and use care the clothes do not touch the diode.

- 1) After the connection, remove solder shown in the right figure.

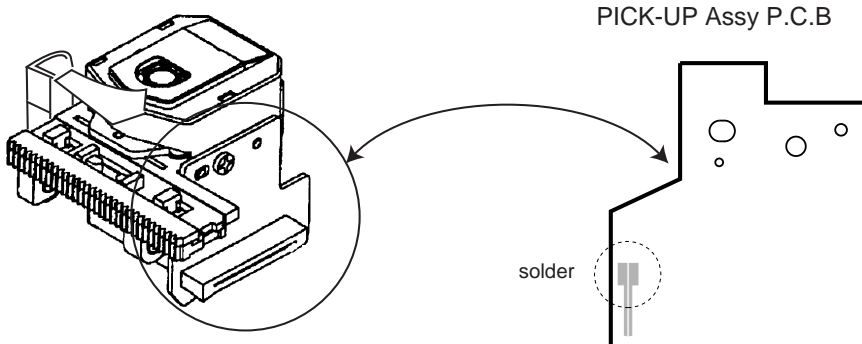

NOTE ON BEFORE STARTING REPAIR

1. Forced discharge of electrolytic capacitor of power supply block

When repair is going to be attempted in the set that uses relay circuit in the power supply block, electric potential is kept charged across the electrolytic capacitors (C101, 102) even though AC power cord is removed. If repair is attempted in this condition, secondary defect can occur.

In order to prevent the secondary trouble, perform the following measures before starting repair work.

Discharge procedure

- 1 Remove the AC power cord.
- 2 Connect a discharging resistor at an end of lead wire that has clips at both ends. Connect the other end of the lead wire to metal chassis.
- 3 Contact the other end of the discharging resistor to the positive (+) side (+VH) of C101. (For two seconds)
- 4 Contact the same end of the discharging resistor as step 3 to the negative (-) side (-VH) of C102 in the same way. (For two seconds)
- 5 Check that voltage across C101 and C102 has decreased to 1 V or less using a multimeter or an oscilloscope.

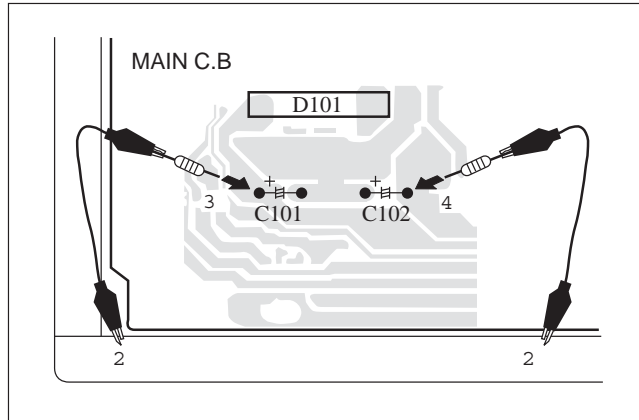

Fig-1

Select a discharging resistor referring to the following table.

Charging voltage (V) (C101, 102)	Discharging resistor (Ω)	Rated power (W)	Parts number
25-48	100	3	87-A00-247-090
49-140	220	5	87-A00-232-090

Note: The reference numbers (C101, C102) of the electrolytic capacitors can change depending on the models. Be sure to check the reference numbers of the charging capacitors on schematic diagram before starting the discharging work.

2. Check items before exchanging the MICROCOMPUTER

Be sure to check the following items before exchanging the MICROCOMPUTER. Exchange the MICROCOMPUTER after confirming that the MICROCOMPUTER is surely defective.

2-1. Regarding the HOLD terminal of the MICROCOMPUTER

When the HOLD terminal (INPUT) of the MICROCOMPUTER is "H", the MICROCOMPUTER is judged to be operating correctly. When this terminal is "L", the main power cannot be turned on. Therefore, be sure to check the terminal voltage of the HOLD terminal before exchange.

When the MICROCOMPUTER is not defective, the HOLD terminal can also go "L" when the POWER AMPLIFIER has any abnormalities that triggers the abnormality detection circuit on the MAIN C. B. that sets the HOLD terminal to "L".

- Good or no good judgement of the MICROCOMPUTER

- 1 Turn on the AC main power.
- 2 Confirm that the main power is turned on and the HOLD terminal of the MICROCOMPUTER keeps the "H" level or not.
- 3 When the HOLD terminal is "L" level, the abnormality detection circuit is judged to be working correctly and the MICROCOMPUTER is judged to be good.

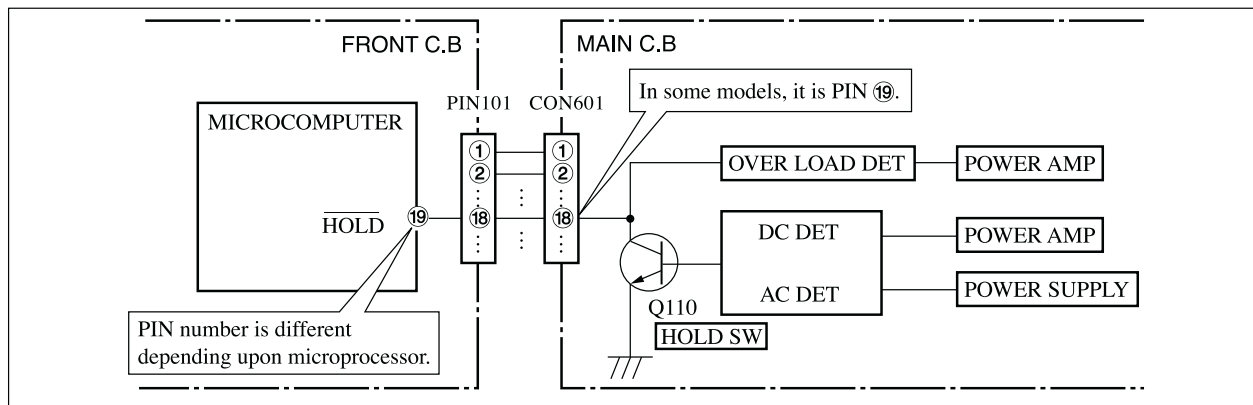

Fig-2-1

In such a case, check also if the POWER AMPLIFIER circuit or power supply circuit has any abnormalities or not.

2-2. Regarding reset

There are cases that the machine does not work correctly because the MICROCOMPUTER is not reset even though the AC power cord is re-inserted, or the software reset (pressing the STOP key + POWER key) is performed.

When the above described phenomenon occurs, it can lead to wrong judgement as if the MICROCOMPUTER is defective and to exchange the MICROCOMPUTER. In such a case, perform the forced-reset by the following procedure and check good or no good of the MICROCOMPUTER.

- 1 Remove the AC power cord.

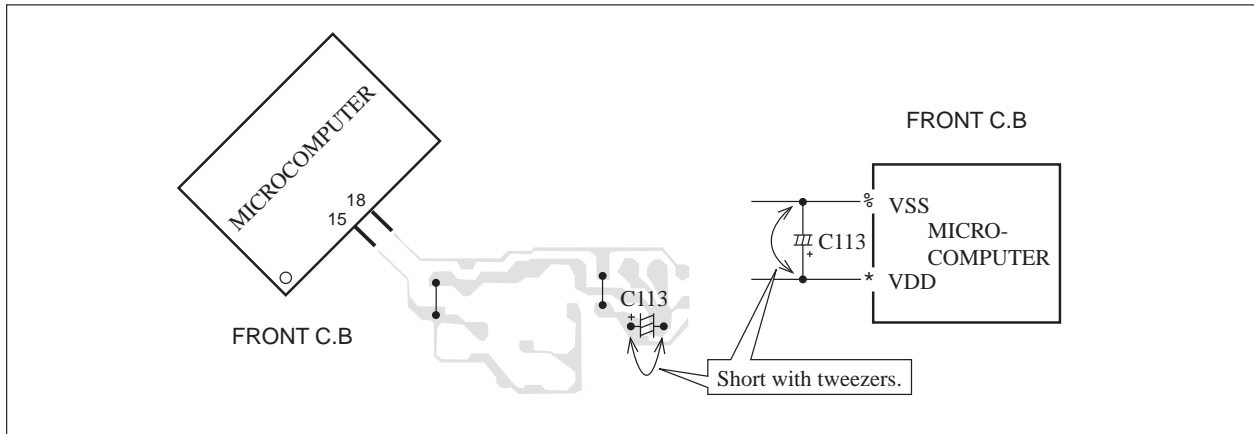

Fig-2-2

- 2 Short both ends of the electrolytic capacitor C113 that is connected to VDD of the MICROCOMPUTER with tweezers.
- 3 Connect the AC power cord again. If the MICROCOMPUTER returns to the normal operation, the MICROCOMPUTER is good.

Note: The reference number or MICROCOMPUTER pin number of transistor (Q110) and electrolytic capacitor (C113) can change depending on the models. Be sure to check the reference numbers on schematic diagram before starting the discharging work.

2-3. Confirmation of soldering state of MICROCOMPUTER

Check the soldering state of the MICROCOMPUTER in addition to the above described procedures. Be sure to exchange the MICROCOMPUTER after surely confirming that the trouble is not caused by poor soldering but the MICROCOMPUTER itself.

ELECTRICAL MAIN PARTS LIST

REF. NO.	PART NO.	KANRI NO.	DESCRIPTION	REF. NO.	PART NO.	KANRI NO.	DESCRIPTION
IC				C21	87-A10-520-000		CAP,E 3300-35 M SMG
	87-A21-397-010	IC,STK490-070		C22	87-A10-520-000		CAP,E 3300-35 M SMG
	87-A21-419-040	IC,NJM14558MD-TE2		C25	87-010-385-080		CAP, ELECT 220-25V
	87-A21-401-040	C-IC,M61503FP		C26	87-010-247-080		CAP, ELECT 100-50V
	87-A21-415-010	IC,LA1843		C30	87-010-430-080		CAP, ELECT 100-63
	87-A20-440-040	C-IC,BU1920FS<22EZ>		C31	87-010-263-080		CAP, ELECT 100-10V
	8A-NF9-601-010	C-IC,UPD780226GF-012-3BA<20EZ>		C32	87-010-197-080		CAP, CHIP 0.01-25 K B
	8A-NF9-602-010	C-IC,UPD780226GF-059-3BA<22EZ>		C34	87-010-247-080		CAP, ELECT 100-50V
	8A-NF9-601-110	C-IC,UPD780226GF-014-3BA<20K,27EZ>		C35	87-010-380-080		CAP, ELECT 47-16V M 11L
	87-A21-482-010	IC,RPM6938-H4		C36	87-010-381-080		CAP, ELECT 330-16V
	87-070-127-110	IC,LC72131 D		C38	87-010-197-080		CAP, CHIP 0.01-25 K B
	87-A21-269-010	IC,EW732		C60	87-010-403-080		CAP, ELECT 3.3-50V
TRANSISTOR				C61	87-010-260-080		CAP, ELECT 47-25V
	87-026-609-080	TR,KTA1266GR		C97	87-010-196-080		CHIP CAPACITOR,0.1-25
	89-213-702-010	TR,2SB1370 (1.8W)		C99	87-010-196-080		CHIP CAPACITOR,0.1-25
	87-026-610-080	TR,KTC3198GR		C101	87-010-185-080		C-CAP,S 3900P-50 B
	87-A30-076-080	C-TR,2SC3052F		C102	87-010-185-080		C-CAP,S 3900P-50 B
	87-A30-075-080	C-TR,2SA1235F		C103	87-010-545-080		CAP, ELECT 0.22-50V SME
	87-026-245-080	TR,DTC114ES		C104	87-010-545-080		CAP, ELECT 0.22-50V SME
	87-A30-198-080	TR,KTC3199GR		C105	87-010-187-080		CHIP CAP 5600P-50 K B
	87-A30-074-080	C-TR,RT1P 141C		C106	87-010-187-080		CHIP CAP 5600P-50 K B
	87-A30-073-080	C-TR,RT1N 141C		C107	87-010-404-080		CAP, ELECT 4.7-50V
	87-A30-107-070	C-TR,CMBT5401		C108	87-010-404-080		CAP, ELECT 4.7-50V
	87-A30-106-040	C-TR,CMBT5551		C109	87-010-322-080		C-CAP,S 100P-50 CH
	87-026-235-080	CHIP-TR,DTC114EK		C110	87-010-322-080		C-CAP,S 100P-50 CH
	87-A30-087-080	C-FET,2SK2158		C111	87-010-391-080		CAP,E 10-35 SME
	87-A30-091-080	FET,2SJ460		C112	87-010-391-080		CAP,E 10-35 SME
	87-A30-090-080	FET,2SK2541		C113	87-010-405-080		CAP, ELECT 10-50V
	87-A30-104-080	C-TR,RT1N 441C		C114	87-010-405-080		CAP, ELECT 10-50V
	89-333-317-880	TR,2SC3331 (0.5W)		C119	87-010-197-080		C-CAP,S 0.01-25 K B
	87-A30-318-080	TR,CSA952K		C120	87-010-197-080		C-CAP,S 0.01-25 K B
	87-A30-329-080	TR,CD1585BC		C123	87-010-176-080		C-CAP,S 680P-50 J SL
	89-327-143-080	TR,2SC2714 (0.1W)		C124	87-010-176-080		C-CAP,S 680P-50 J SL
	87-A30-072-080	C-TR,RT1P 144C		C125	87-012-368-080		C-CAP,S 0.1-50 F
	87-A30-234-080	TR,CSC4115BC		C126	87-012-368-080		C-CAP,S 0.1-50 F
	87-A30-468-080	C-TR,KRC102S-RTK		C127	87-012-368-080		C-CAP,S 0.1-50 F
	87-A30-086-040	C-TR,CSD1306E		C128	87-012-368-080		C-CAP,S 0.1-50 F
	89-503-602-080	C-FET 2SK360E		C129	87-010-191-080		C-CAP,S 0.015-50 F
	87-A30-062-080	C-TR,KRC104S		C130	87-010-191-080		C-CAP,S 0.015-50 F
DIODE				C131	87-010-197-080		CAP, CHIP 0.01-25 K B
	87-A40-553-080	DIODE,1N4003 LES		C132	87-010-197-080		CAP, CHIP 0.01-25 K B
	87-A40-776-080	ZENER,UZ27BSD		C133	87-010-186-080		CAP,CHIP 4700P-50 K
	87-A40-764-080	ZENER,UZ10BSC		C140	87-010-182-080		C-CAP,S 2200P-50 B
	87-A40-313-080	C-DIODE,MC 2840		C141	87-010-196-080		CHIP CAPACITOR,0.1-25
	87-A40-270-080	C-DIODE,MC2838		C239	87-010-196-080		CHIP CAPACITOR,0.1-25
	87-A40-269-080	C-DIODE,MC2836		C301	87-010-178-080		C-CAP,S 1000-50 K B
	87-A40-752-080	ZENER,UZ6.2BSC		C302	87-010-178-080		C-CAP,S 1000-50 K B
	87-A40-739-080	ZENER,UZ2.7BSA		C303	87-010-178-080		C-CAP,S 1000-50 K B
	87-017-149-080	ZENER,HZS6A2L		C304	87-010-178-080		C-CAP,S 1000-50 K B
	87-020-465-080	DIODE,1SS133		C307	87-010-263-080		CAP, ELECT 100-10V
	87-A40-854-080	ZENER,UZ15BSA		C308	87-010-263-080		CAP, ELECT 100-10V
MAIN C.B				C309	87-010-318-080		C-CAP,S 47P-50 CH
C3	87-012-368-080	C-CAP,S 0.1-50 F		C310	87-010-318-080		C-CAP,S 47P-50 CH
C4	87-012-368-080	C-CAP,S 0.1-50 F		C313	87-010-188-080		CAP,CHIP 6800P-50 K
C5	87-012-368-080	C-CAP,S 0.1-50 F		C314	87-010-188-080		CAP,CHIP 6800P-50 K
C6	87-012-368-080	C-CAP,S 0.1-50 F		C315	87-010-263-080		CAP, ELECT 100-10V
C9	87-012-368-080	C-CAP,S 0.1-50 F		C317	87-010-546-080		CAP, ELECT 0.33-50V
C10	87-012-368-080	C-CAP,S 0.1-50 F		C318	87-010-546-080		CAP, ELECT 0.33-50V
C11	87-012-368-080	C-CAP,S 0.1-50 F		C326	87-010-198-080		CAP, CHIP 0.022-25 K
C12	87-012-368-080	C-CAP,S 0.1-50 F		C327	87-012-368-080		C-CAP,S 0.1-50 F
C19	87-A10-627-000	CAP,E 2200-50 SMG		C360	87-010-401-080		CAP, ELECT 1-50V
C20	87-A10-627-000	CAP,E 2200-50 SMG		C399	87-012-140-080		C-CAP,S 470P-50 J
				C401	87-010-544-080		CAP, ELECT 0.1-50V
				C402	87-010-544-080		CAP, ELECT 0.1-50V
				C403	87-010-321-080		CHIP CAPACITOR,82P(J)
				C404	87-010-321-080		CHIP CAPACITOR,82P(J)
				C405	87-010-197-080		CAP, CHIP 0.01-25 K B
				C406	87-010-197-080		CAP, CHIP 0.01-25 K B
				C407	87-010-197-080		CAP, CHIP 0.01-25 K B
				C408	87-010-197-080		CAP, CHIP 0.01-25 K B

REF. NO.	PART NO.	KANRI NO.	DESCRIPTION	REF. NO.	PART NO.	KANRI NO.	DESCRIPTION
C409	87-010-182-080		C-CAP,S 2200P-50 B	C823	87-012-349-080		C-CAP,S 1000P-50 J CH
C410	87-010-182-080		C-CAP,S 2200P-50 B	C824	87-010-405-080		CAP, ELECT 10-50V
C411	87-010-405-080		CAP, ELECT 10-50V	C825	87-010-596-080		CAP, S 0.047-16
C412	87-010-405-080		CAP, ELECT 10-50V	C831	87-010-406-080		CAP, ELECT 22-50 M SME
C452	87-010-382-080		CAP, ELECT 22-25V	C842	87-010-197-080		CAP, CHIP 0.01-25 K B
C453	87-010-183-080		C-CAP,S 2700P-50 B	C844	87-010-197-080		CAP, CHIP 0.01-25 K B
C454	87-010-183-080		C-CAP,S 2700P-50 B	C850	87-010-260-080		CAP, ELECT 47-25V
C455	87-010-183-080		C-CAP,S 2700P-50 B	C851	87-010-197-080		CAP, CHIP 0.01-25 K B
C456	87-010-197-080		CAP, CHIP 0.01-25 K B	C852	87-010-197-080		CAP, CHIP 0.01-25 K B
C460	87-010-196-080		CHIP CAPACITOR,0.1-25	C853	87-010-197-080		CAP, CHIP 0.01-25 K B
C461	87-012-158-080		C-CAP,S 390P-50 CH	C858	87-010-196-080		CHIP CAPACITOR,0.1-25
C462	87-012-158-080		C-CAP,S 390P-50 CH	C859	87-010-196-080		CHIP CAPACITOR,0.1-25
C458	87-010-178-080		C-CAP,S 1000-50 K B	C860	87-010-197-080		CAP, CHIP 0.01-25 K B
C459	87-010-175-080		C-CAP,S 560P-50 J SL	C869	87-010-197-080		CAP, CHIP 0.01-25 K B<22EZ>
C605	87-010-179-080		CAP,CHIP S 1200P-50 K	C871	87-012-156-010		C-CAP,S 2200P-50 J CH<22EZ>
C606	87-010-179-080		CAP,CHIP S 1200P-50 K	C872	87-012-156-010		C-CAP,S 2200P-50 J CH<22EZ>
C609	87-010-213-080		C-CAP,S 0.015-50 B	C873	87-012-140-080		C-CAP,S 470P-50 J CH<22EZ>
C610	87-010-213-080		C-CAP,S 0.015-50 B	C874	87-010-405-080		CAP, ELECT 10-50V<22EZ>
C611	87-010-545-080		CAP, ELECT 0.22-50V	C876	87-010-405-080		CAP, ELECT 10-50V<22EZ>
C612	87-010-545-080		CAP, ELECT 0.22-50V	C877	87-010-197-080		CAP, CHIP 0.01-25 K B<22EZ>
C613	87-010-545-080		CAP, ELECT 0.22-50V	C878	87-010-316-080		C-CAP,S 33P-50 J CH GRM<22EZ>
C614	87-010-545-080		CAP, ELECT 0.22-50V	C879	87-010-314-080		C-CAP,S 22P-50 J CH GRM<22EZ>
C615	87-010-154-080		CAP CHIP 10P-50 CH	C940	87-010-197-080		CAP, CHIP 0.01-25 K B
C616	87-010-221-080		CAP, ELECT 470-10V SME	C942	87-010-149-080		C-CAP,S 5P-50 CH
C617	87-010-221-080		CAP, ELECT 470-10V SME	C947	87-010-197-080		CAP, CHIP 0.01-25 K B
C618	87-010-405-080		CAP, ELECT 10-50V	C948	87-012-140-080		C-CAP,S 470P-50 J CH
C630	87-016-669-080		C-CAP,S 0.1-25 K B	C952	87-010-197-080		CAP, CHIP 0.01-25 K B
C631	87-010-185-080		C-CAP,S 3900P-50 B	C957	87-010-311-080		C-CAP,S 12P-50 J CH
C632	87-010-185-080		C-CAP,S 3900P-50 B	C958	87-010-197-080		CAP, CHIP 0.01-25 K B
C633	87-016-369-080		C-CAP,S 0.033-25 K B	C959	87-010-196-080		CHIP CAPACITOR,0.1-25
C634	87-016-369-080		C-CAP,S 0.033-25 K B	C960	87-010-196-080		CHIP CAPACITOR,0.1-25
C669	87-010-322-080		C-CAP,S 100P-50 CH	C961	87-010-152-080		C-CAP,S 8P-50 CH
C670	87-010-322-080		C-CAP,S 100P-50 CH	C962	87-010-401-080		CAP, ELECT 1-50V
C677	87-010-197-080		CAP, CHIP 0.01-25 K B	C963	87-015-785-080		CHIP CAPACITOR, 0.1FZ-25Z
C779	87-010-971-080		C-CAP,S 4700P-50 J B	C971	87-010-381-080		CAP, ELECT 330-16V
C780	87-010-971-080		C-CAP,S 4700P-50 J B	C972	87-010-404-080		CAP, ELECT 4.7-50V
C771	87-010-263-080		CAP, ELECT 100-10V	C973	87-010-197-080		CAP, CHIP 0.01-25 K B
C772	87-010-197-080		CAP, CHIP 0.01-25 K B	C974	87-010-197-080		CAP, CHIP 0.01-25 K B
C779	87-A10-801-080		C-CAP,S 0.022-16 J B	C979	87-010-322-080		C-CAP,S 100P-50 CH
C780	87-A10-801-080		C-CAP,S 0.022-16 J B	C981	87-010-260-080		CAP, ELECT 47-25V
C782	87-010-197-080		CAP, CHIP 0.01-25 K B	C982	87-010-196-080		CHIP CAPACITOR,0.1-25
C783	87-010-197-080		CAP, CHIP 0.01-25 K B	C983	87-010-197-080		CAP, CHIP 0.01-25 K B
C784	87-010-197-080		CAP, CHIP 0.01-25 K B	C984	87-010-197-080		CAP, CHIP 0.01-25 K B
C785	87-010-197-080		CAP, CHIP 0.01-25 K B	C985	87-010-322-080		C-CAP,S 100P-50 J CH
C786	87-010-197-080		CAP, CHIP 0.01-25 K B	C987	87-010-197-080		CAP, CHIP 0.01-25 K B
C788	87-010-149-080		C-CAP,S 5P-50 CH	C989	87-010-197-080		CAP, CHIP 0.01-25 K B
C789	87-A11-532-080		C-CAP,S 0.022-50 J	C991	87-010-312-080		C-CAP,S 15P-50 CH
C790	87-A11-532-080		C-CAP,S 0.022-50 J	C992	87-010-312-080		C-CAP,S 15P-50 CH
C791	87-010-196-080		CHIP CAPACITOR,0.1-25	C993	87-010-178-080		CHIP CAP 1000P-50 K B
C792	87-010-197-080		CAP, CHIP 0.01-25 K B	C995	87-010-178-080		CHIP CAP 1000P-50 K B
C793	87-010-404-080		CAP, ELECT 4.7-50V	C997	87-010-196-080		CHIP CAPACITOR,0.1-25
C795	87-010-197-080		CAP, CHIP 0.01-25 K B	C998	87-010-260-080		CAP, ELECT 47-25V
C796	87-010-197-080		CAP, CHIP 0.01-25 K B	C999	87-A11-155-080		CAP,TC U 0.01-16 Z F
C797	87-010-405-080		CAP, ELECT 10-50V	CF831	87-008-423-010		FILTER, SFE10.7MS3G-A
C798	87-010-197-080		CAP, CHIP 0.01-25 K B	CF832	82-785-747-010		CF, MS2 GHYR
C799	87-010-407-080		CAP, ELECT 33-50V	CN301	87-A60-620-010		CONN,3P V 2MM JMT
C800	87-012-369-080		C-CAP,S 0.047-50F	CN351	87-A60-625-010		CONN,8P V 2MM JMT
C801	87-010-403-080		CAP, ELECT 3.3-50V	CN601	87-099-719-010		CONN,30P TYK-B(X)
C802	87-010-194-080		CAP, CHIP 0.047-25 Z F	CN602	87-A60-131-010		CONN,6P V FE
C803	87-010-198-080		CAP, CHIP 0.022-25 K B	D951	87-A40-618-080		VARI-CAP,SVC 348
C804	87-010-263-080		CAP, ELECT 100-10V	FC602	88-906-251-110		FF-CABLE,6P 1.25
C807	87-010-400-080		CAP, ELECT 0.47-50V	FB303	87-008-474-080		F-BEAD BL02RN1-R62T2 EMI
C808	87-010-401-080		CAP, ELECT 1-50V	FFB831	A8-6ZA-19C-170		6ZA-1 YFEENC<20K>
C809	87-010-401-080		CAP, ELECT 1-50V	FFB831	A8-6ZA-191-030		6ZA-1 FEENM<20EZ,22EZ,27EZ>
C810	87-010-196-080		CHIP CAPACITOR,0.1-25	J202	87-A60-488-010		JACK,DIA6.3 BLK ST W/SW KM16AT
C814	87-010-197-080		CAP, CHIP 0.01-25 K B	J203	87-A60-238-010		TERMINAL,SP 4P (MSC)
C815	87-010-400-080		CAP, ELECT 0.47-50V	J602	87-A60-881-010		JACK,PIN 2P MSP 242V05 PBSN
C816	87-010-400-080		CAP, ELECT 0.47-50V	J832	87-A60-403-010		TERMINAL,ANT PAL 2P HSP-312V05
C818	87-010-180-080		C-CAP,S 1000P-50 J CH	L101	87-A50-610-010		COIL,1UH-K
C821	87-010-405-080		CAP, ELECT 10-50V	L102	87-A50-610-010		COIL,1UH-K

REF. NO.	PART NO.	KANRI NO.	DESCRIPTION	REF. NO.	PART NO.	KANRI NO.	DESCRIPTION
L451	87-007-342-010		COIL, OSC 85K BIAS	C921	87-010-186-080		CAP, CHIP 4700P-50 K B
L801	87-A50-540-010		COIL, FM DET (TOK)	C951	87-010-312-080		C-CAP, S 15P-50 CH
L802	87-A91-551-010		FLTR, PCFJZH-450 L (TOK)	C952	87-012-155-080		C-CAP 180P-50CH
L811	87-005-847-080		COIL, 2.2UH (CECS)	C953	87-012-140-080		CAP 470P-50 CH
L832	87-005-847-080		COIL, 2.2UH (CECS)	C961	87-010-378-040		CAP, E 10-16 M SME
L941	87-A50-020-010		COIL, ANT LW (COI) 252KHZ	C962	87-012-157-080		C-CAP, S 330P-50 CH
L942	87-A50-019-010		COIL, OSC LW (COI) 856KHZ	C963	87-010-196-080		CHIP CAPACITOR, 0.1-25
L951	8A-NF8-668-010		COIL, AM PACK 2 (TOK)	CN104	87-A60-057-010		CONN, 11P V 9604S-11C
R131	87-A00-258-080		RES, M/F 0.22-1W J	CN701	87-099-720-010		CONN, 30P BLK TYK-B (P)
R132	87-A00-258-080		RES, M/F 0.22-1W J	CN731	87-099-015-010		CONN, 13P V BLK 6216V
R143	87-A00-440-050		RES, 220-1/2W J RP	FC104	88-911-101-110		FF-CABLE, 11P 1.25
R144	87-A00-440-050		RES, 220-1/2W J RP	FC731	88-913-301-110		FF-CABLE, 13P-1.25
R145	87-A00-440-050		RES, 220-1/2W J RP	FL901	8A-NF9-605-010		FL, HNA-10SS12
R146	87-A00-440-050		RES, 220-1/2W J RP	L951	87-A50-434-010		COIL, CLK 4.19M (TOKO)
R653	87-A11-144-080		CAP, TC U 0.1-50 KB	LED201	87-A40-619-040		LED, SLR-56PT-T31-W GRN
R654	87-A11-144-080		CAP, TC U 0.1-50 KB	LED202	87-A40-619-040		LED, SLR-56PT-T31-W GRN
R790	87-010-197-080		CAP, CHIP 0.01 DM	LED204	87-A40-619-040		LED, SLR-56PT-T31-W GRN
R991	87-010-322-080		C-CAP, S 100P-50 CH	LED205	87-A40-619-040		LED, SLR-56PT-T31-W GRN
R993	87-010-322-080		C-CAP, S 100P-50 CH	LED209	87-A40-317-080		LED, SLR-342VCT31 RED
R995	87-010-322-080		C-CAP, S 100P-50 CH	LED210	87-A40-619-040		LED, SLR-56PT-T31-W GRN
SFR451	87-A90-432-080		SFR, 30K H NVZ6TLTA	S301	87-A91-024-180		SW, TACT KSH0611BT<20EZ, 20K, 22EZ>
SFR452	87-A90-432-080		SFR, 30K H NVZ6TLTA	S301	87-A90-164-080		SW, TACT SKQNB (N) <27EZ>
TC942	87-011-253-080		TRIMMER, CER 30P 4.0X4.5 ECRLA	S302	87-A91-024-180		SW, TACT KSH0611BT<20EZ, 20K, 22EZ>
W99	8A-NF9-609-010		F-CABLE, 9P 2.5 480MM	S302	87-A90-164-080		SW, TACT SKQNB (N) <27EZ>
WH1	87-A90-510-010		HLDR, WIRE 2.5-9P	S303	87-A91-024-180		SW, TACT KSH0611BT<20EZ, 20K, 22EZ>
X861	87-A70-091-010		VIB, XTAL 4.332MHZ CSA-309	S303	87-A90-164-080		SW, TACT SKQNB (N) <27EZ>
X991	87-A70-061-010		VIB, XTAL 4.500MHZ CSA-309	S304	87-A91-024-180		SW, TACT KSH0611BT<20EZ, 20K, 22EZ>
				S304	87-A90-164-080		SW, TACT SKQNB (N) <27EZ>
				S305	87-A91-024-180		SW, TACT KSH0611BT<20EZ, 20K, 22EZ>
				S305	87-A90-164-080		SW, TACT SKQNB (N) <27EZ>
FRONT C.B							
C101	87-010-196-080		CHIP CAPACITOR, 0.1-25	S306	87-A91-024-180		SW, TACT KSH0611BT<20EZ, 20K, 22EZ>
C102	87-010-196-080		CHIP CAPACITOR, 0.1-25	S306	87-A90-164-080		SW, TACT SKQNB (N) <27EZ>
C103	87-010-498-040		CAP, E 10-16 M 5L	S307	87-A91-024-180		SW, TACT KSH0611BT<20EZ, 20K, 22EZ>
C104	87-010-196-080		CHIP CAPACITOR, 0.1-25	S307	87-A90-164-080		SW, TACT SKQNB (N) <27EZ>
C107	87-010-493-040		CAP, E 0.47-50 M 5L	S308	87-A91-024-180		SW, TACT KSH0611BT<20EZ, 20K, 22EZ>
C108	87-012-393-080		C-CAP, S 0.22-16 K	S308	87-A90-164-080		SW, TACT SKQNB (N) <27EZ>
C153	87-010-198-080		CAP, CHIP 0.022-25 K B	S309	87-A91-024-180		SW, TACT KSH0611BT<20EZ, 20K, 22EZ>
C154	87-010-246-040		CAP, E 47-35 SME	S309	87-A90-164-080		SW, TACT SKQNB (N) <27EZ>
C155	87-010-404-040		CAP, E 4.7-50 SME	S321	87-A91-024-180		SW, TACT KSH0611BT<20EZ, 20K, 22EZ>
C156	87-010-404-040		CAP, E 4.7-50 SME	S321	87-A90-164-080		SW, TACT SKQNB (N) <27EZ>
C361	87-010-178-080		CHIP CAP 1000P-50 K B	S322	87-A91-024-180		SW, TACT KSH0611BT<20EZ, 20K, 22EZ>
C362	87-010-178-080		CHIP CAP 1000P-50 K B	S322	87-A90-164-080		SW, TACT SKQNB (N) <27EZ>
C371	87-010-178-080		CHIP CAP 1000P-50 K B	S323	87-A91-024-180		SW, TACT KSH0611BT<20EZ, 20K, 22EZ>
C372	87-010-178-080		CHIP CAP 1000P-50 K B	S323	87-A90-164-080		SW, TACT SKQNB (N) <27EZ>
C601	87-010-382-040		CAP, E 22-25 SME	S324	87-A91-024-180		SW, TACT KSH0611BT<20EZ, 20K, 22EZ>
C801	87-010-195-080		C-CAP, S 0.068-25 F	S324	87-A90-164-080		SW, TACT SKQNB (N) <27EZ>
C802	87-010-195-080		C-CAP, S 0.068-25 F	S325	87-A91-024-180		SW, TACT KSH0611BT<20EZ, 20K, 22EZ>
C803	87-010-402-040		CAP, E 2.2-50 SME	S325	87-A90-164-080		SW, TACT SKQNB (N) <27EZ>
C804	87-010-402-040		CAP, E 2.2-50 SME	S326	87-A91-024-180		SW, TACT KSH0611BT<20EZ, 20K, 22EZ>
C805	87-010-196-080		CHIP CAPACITOR, 0.1-25	S326	87-A90-164-080		SW, TACT SKQNB (N) <27EZ>
C806	87-010-196-080		CHIP CAPACITOR, 0.1-25	S327	87-A91-024-180		SW, TACT KSH0611BT<22EZ>
C901	87-010-322-080		C-CAP, S 100P-50 CH	S328	87-A91-024-180		SW, TACT KSH0611BT<22EZ>
C902	87-010-322-080		C-CAP, S 100P-50 CH	S329	87-A91-024-180		SW, TACT KSH0611BT<22EZ>
C903	87-010-322-080		C-CAP, S 100P-50 CH	S341	87-A91-024-180		SW, TACT KSH0611BT<20EZ, 20K, 22EZ>
C904	87-010-322-080		C-CAP, S 100P-50 CH	S341	87-A90-164-080		SW, TACT SKQNB (N) <27EZ>
C905	87-010-322-080		C-CAP, S 100P-50 CH	S342	87-A91-024-180		SW, TACT KSH0611BT<20EZ, 20K, 22EZ>
C906	87-010-322-080		C-CAP, S 100P-50 CH	S342	87-A90-164-080		SW, TACT SKQNB (N) <27EZ>
C907	87-010-322-080		C-CAP, S 100P-50 CH	S343	87-A91-024-180		SW, TACT KSH0611BT<20EZ, 20K, 22EZ>
C908	87-010-322-080		C-CAP, S 100P-50 CH	S343	87-A90-164-080		SW, TACT SKQNB (N) <27EZ>
C909	87-010-322-080		C-CAP, S 100P-50 CH	S344	87-A91-024-180		SW, TACT KSH0611BT<20EZ, 20K, 22EZ>
C910	87-010-322-080		C-CAP, S 100P-50 CH	S344	87-A90-164-080		SW, TACT SKQNB (N) <27EZ>
C911	87-010-178-080		CHIP CAP 1000P-50 K B	S345	87-A91-024-180		SW, TACT KSH0611BT<20EZ, 20K, 22EZ>
C912	87-010-196-080		CHIP CAPACITOR, 0.1-25	S345	87-A90-164-080		SW, TACT SKQNB (N) <27EZ>
C913	87-010-248-040		CAP, E 220-10 SME	S346	87-A91-024-180		SW, TACT KSH0611BT<20EZ, 20K, 22EZ>
C914	87-010-248-040		CAP, E 220-10 SME	S346	87-A90-164-080		SW, TACT SKQNB (N) <27EZ>
C915	87-010-196-080		CHIP CAPACITOR, 0.1-25	S347	87-A91-024-180		SW, TACT KSH0611BT<20EZ, 20K, 22EZ>
C916	87-010-196-080		CHIP CAPACITOR, 0.1-25	S347	87-A90-164-080		SW, TACT SKQNB (N) <27EZ>
C917	87-010-196-080		CHIP CAPACITOR, 0.1-25	S348	87-A91-024-180		SW, TACT KSH0611BT<20EZ, 20K, 22EZ>
C919	87-010-197-080		CAP, CHIP 0.01-25 K B	S348	87-A90-164-080		SW, TACT SKQNB (N) <27EZ>
C920	87-012-369-080		C-CAP, S 0.047-50 Z F	S349	87-A91-024-180		SW, TACT KSH0611BT<20EZ, 20K, 22EZ>

REF. NO.	PART NO.	KANRI NO.	DESCRIPTION
S349	87-A90-164-080		SW,TACT SKQNAB (N) <27EZ>
S350	87-A91-024-180		SW,TACT KSH0611BT<20EZ,20K,22EZ>
S350	87-A90-164-080		SW,TACT SKQNAB (N) <27EZ>
S361	87-A91-633-010		SW,RTRY XRE012103PVB25FINA 1-2
S371	87-A91-632-010		SW,RTRY XRE012103PVB25FINB 1-2

PT C.B

C183	87-010-387-080	CAP,E 470-25 SME
C184	87-010-403-080	CAP, ELECT 3.3-50V
△ PT1	8A-NF9-612-010	PT,ANF-9 U
△ PT181	8A-NF8-662-010	PT,SUB ANF-8 (E)
△ RY181	87-A91-418-010	RELAY,AC12V G5PA-1-M
△ T181	87-A60-317-010	TERMINAL, 1P MSC
△ T182	87-A60-317-010	TERMINAL, 1P MSC
WH181	87-A90-510-010	HLD, WIRE 2.5-9P

DECK C.B

HL1	8Z-ZM3-214-010	HLD, IC
CN1	87-099-753-010	CONN,11P H 9604
SFR1	87-024-581-010	SFR,3.3K DIA6V K0A
SW1	87-A90-673-010	SW,MICRO ESE11SH1C
SW2	87-A91-500-010	SW,MICRO MPU11470MLB0
SW3	87-A91-500-010	SW,MICRO MPU11470MLB0
SW4	87-A91-500-010	SW,MICRO MPU11470MLB0
SW5	87-A90-673-010	SW,MICRO ESE11SH1C

○チップ抵抗部品コード/CHIP RESISTOR PART CODE

チップ抵抗部品コードの成り立ち

Chip Resistor Part Coding

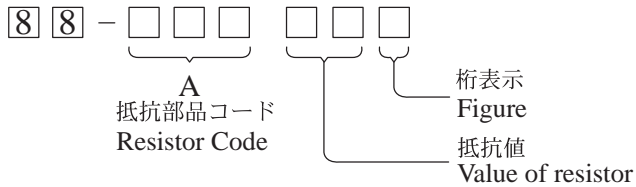

チップ抵抗
Chip resistor

容量 Wattage	種類 Type	許容誤差 Tolerance	記号 Symbol	寸法/Dimensions (mm)			抵抗コード : A Resistor Code : A	
				外形/Form	L	W		t
1/16W	1005	± 5%	CJ		1.0	0.5	0.35	104
1/16W	1608	± 5%	CJ		1.6	0.8	0.45	108
1/10W	2125	± 5%	CJ		2	1.25	0.45	118
1/8W	3216	± 5%	CJ		3.2	1.6	0.55	128

TRANSISTOR ILLUSTRATION



E C B

CD1585BC
CSA952K
KTA1266GR
KTC3198GR



E C B

2SC3331



E C B

CSC4115BC

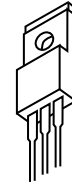

B C E

2SB1370



E C B

DTC114ES
KTC3199GR

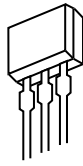

S D G

2SJ460
2SK2541

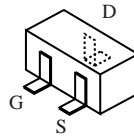

2SK2158

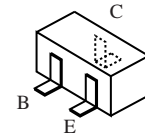

2SA1235F DTC114EK
2SC2714 KRC102S
2SC3052F KRC104S
CMBT5401 RT1N141C
CMBT5551 RT1N441C
CSD1306E RT1P141C
RT1P144C

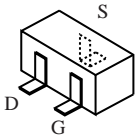

2SK360E

FL (HNA-10SS12) GRID ASSIGNMENT AND ANODE CONNECTION

GRID ASSIGNMENT

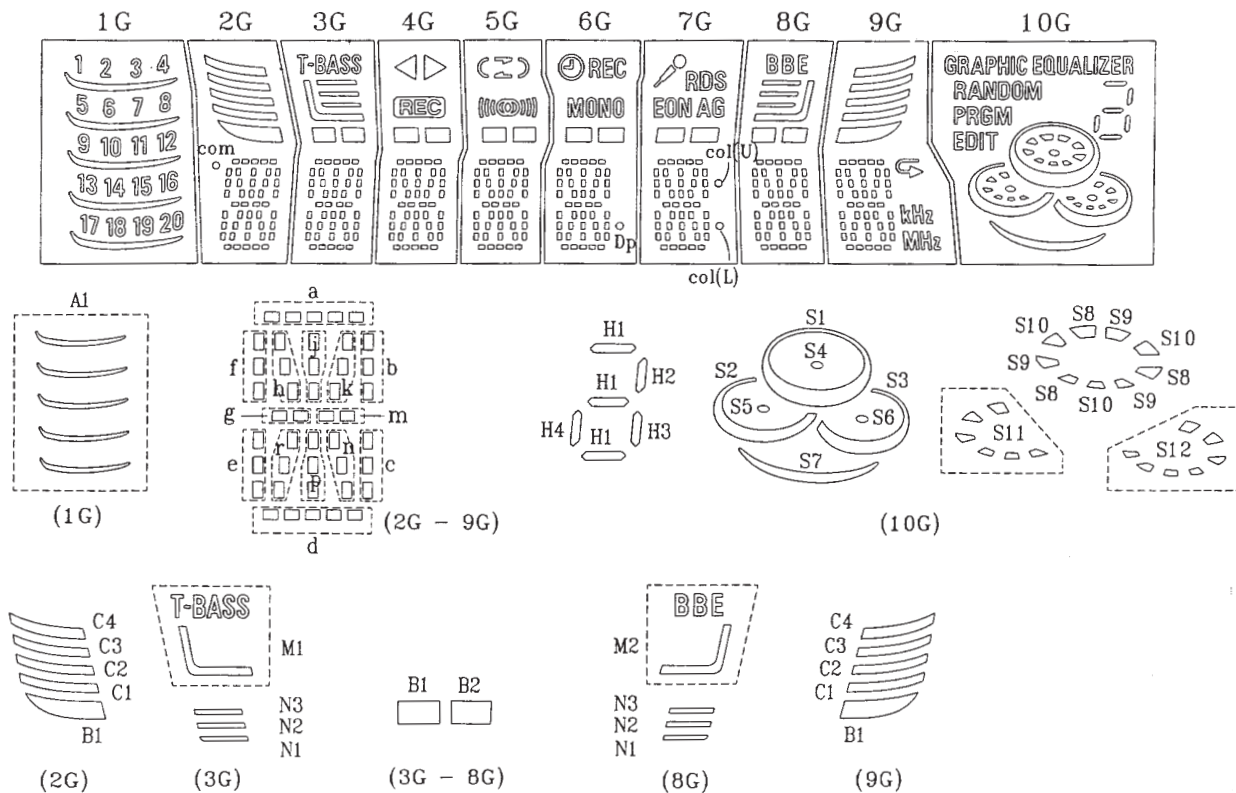

ANODE CONNECTION

	1G	2G	3G	4G	5G	6G	7G	8G	9G	10G
P1	20	d	d	d	d	d	d	d	d	S1
P2	19	n	n	n	n	n	n	n	n	S2
P3	18	p	p	p	p	p	p	p	p	S3
P4	17	r	r	r	r	r	r	r	r	S4
P5	16	e	e	e	e	e	e	e	e	S5
P6	15	c	c	c	c	c	c	c	c	S6
P7	14	g	g	g	g	g	g	g	g	S7
P8	13	m	m	m	m	m	m	m	m	S8
P9	12	f	f	f	f	f	f	f	f	S9
P10	11	b	b	b	b	b	b	b	b	S10
P11	10	k	k	k	k	k	k	k	k	S11
P12	9	j	j	j	j	j	j	j	j	S12
P13	8	h	h	h	h	h	h	h	h	EDIT
P14	7	a	a	a	a	a	a	a	a	PRGM
P15	6	B1	B1	B1	B1	B1	B1	B1	B1	RANDOM
P16	5	C1	B2	B2	B2	B2	B2	B2	C1	GRAPHIC EQUALIZER
P17	4	C2	M1	REC	((MON))	Dp	col(U)	M2	C2	H1
P18	3	C3	N1	<	C	MONO	col(L)	N1	C3	H2
P19	2	C4	N2	>	Z	REC	EON	N2	C4	H3
P20	1	com	N3	/)	AG	RDS	N3	↻	H4
P21	A1	/	/	/	/	/	/	/	/	kHz
P22	/	/	/	/	/	/	/	/	/	MHz

1 2 3 4 5 6 7 8 9 10 11 12 13 14 15 16 17 18 19 20 21 22 23 24 25 26 27 28 29 30 31 32

A B C D E F G H I J K L M N O P Q R S T U

TO CB MECHANISM AZG-1



CA02
CN602

A MAIN C.B



TO DECK1
CN501

TO DECK2
CN551

TO CN501

TO CN551

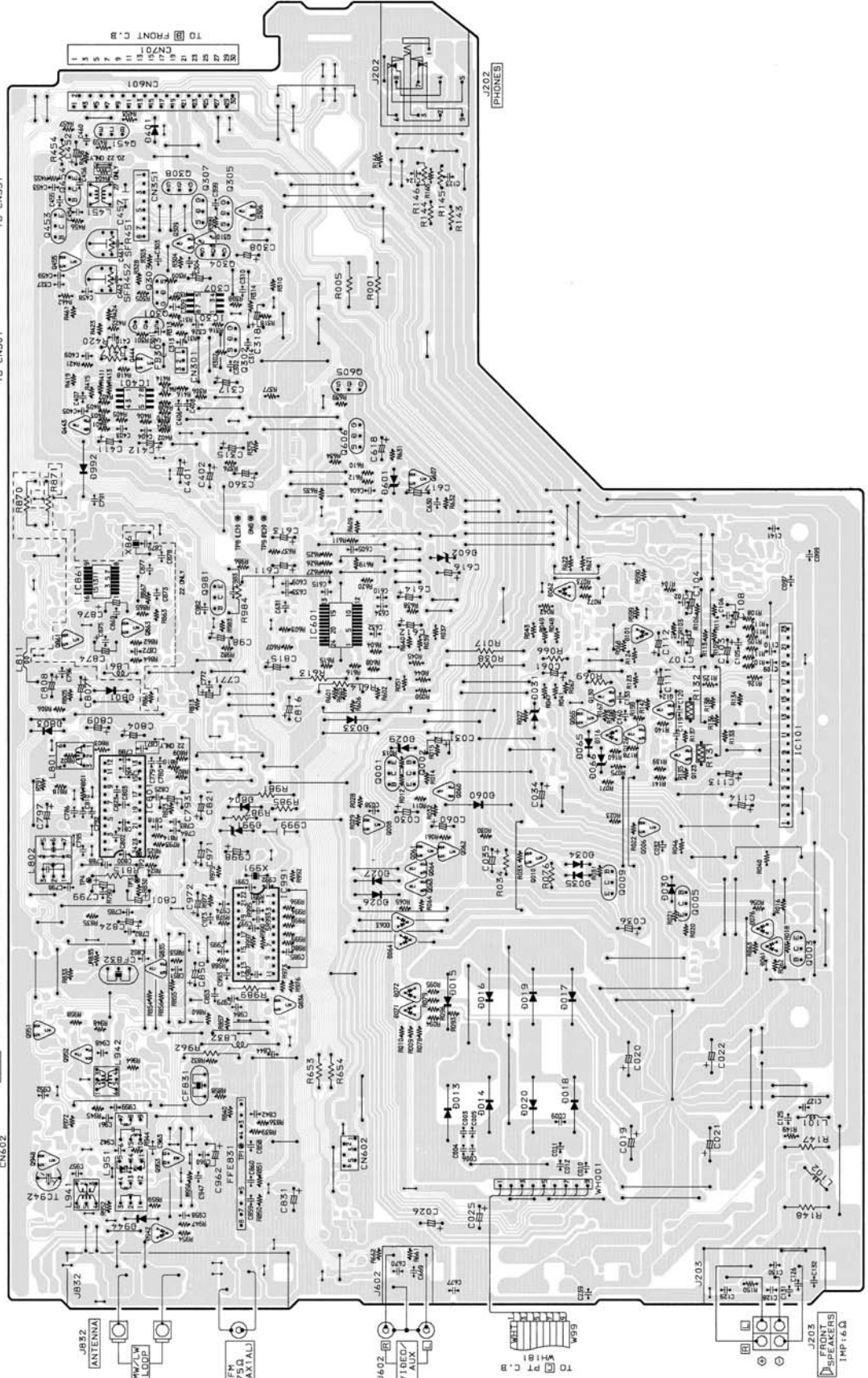

SCHEMATIC DIAGRAM - 1 (MAIN 1/2:AMP)

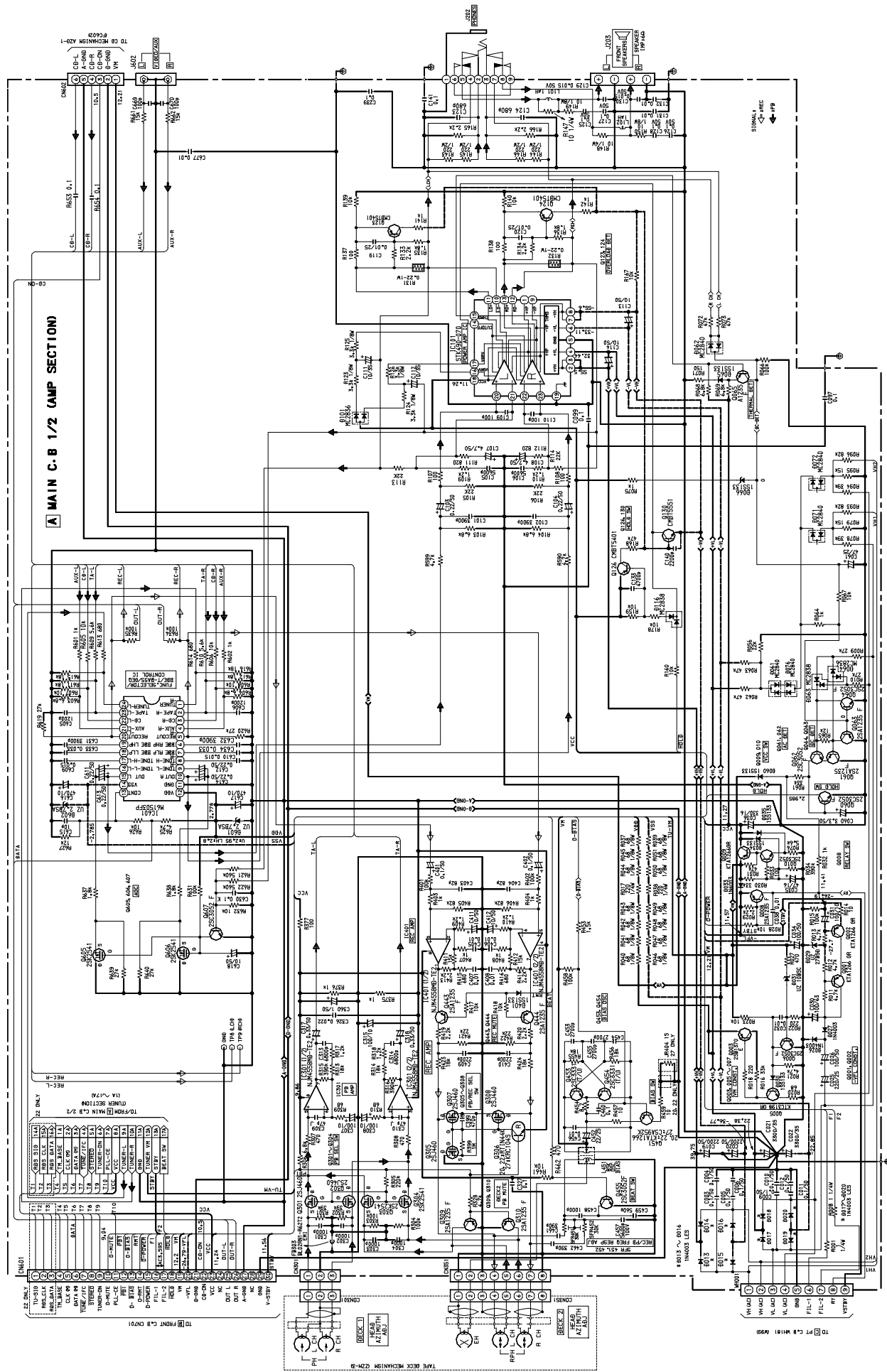

A B C D E F G H I J K L M N O P Q R S T U

1 2 3 4 5 6 7 8 9 10 11 12 13 14 15 16 17 18 19 20 21 22 23 24 25 26 27 28 29 30 31 32

B FRONT C. B

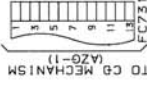
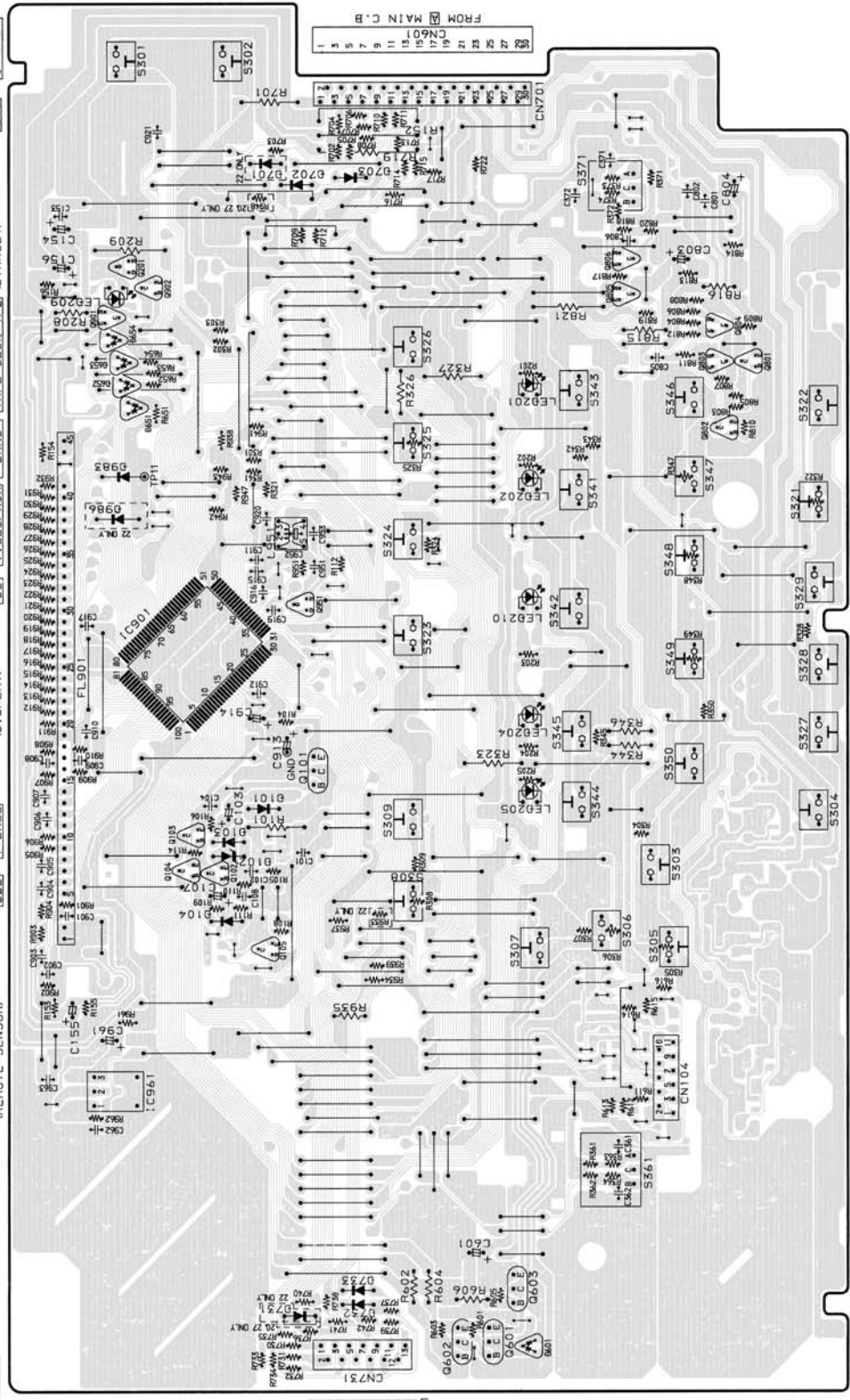

TO C9 MECHANISM (A26-1)

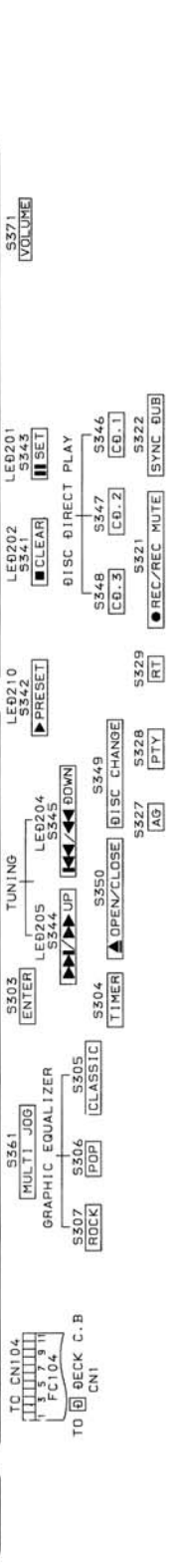

TO CN104
MULTI JOG
GRAPHIC EQUALIZER
S307 ROCK POP CLASSIC
TIMER
ENTER
TUNING
UP DOWN
OPEN/CLOSE DISC CHANGE
AG RT PTY
PRESET
CLEAR SET
DISC DIRECT PLAY
S348 S347 S346
CD.3 CD.2 CD.1
REC/REC MUTE SYNC DUB

SCHEMATIC DIAGRAM - 3 (FRONT)

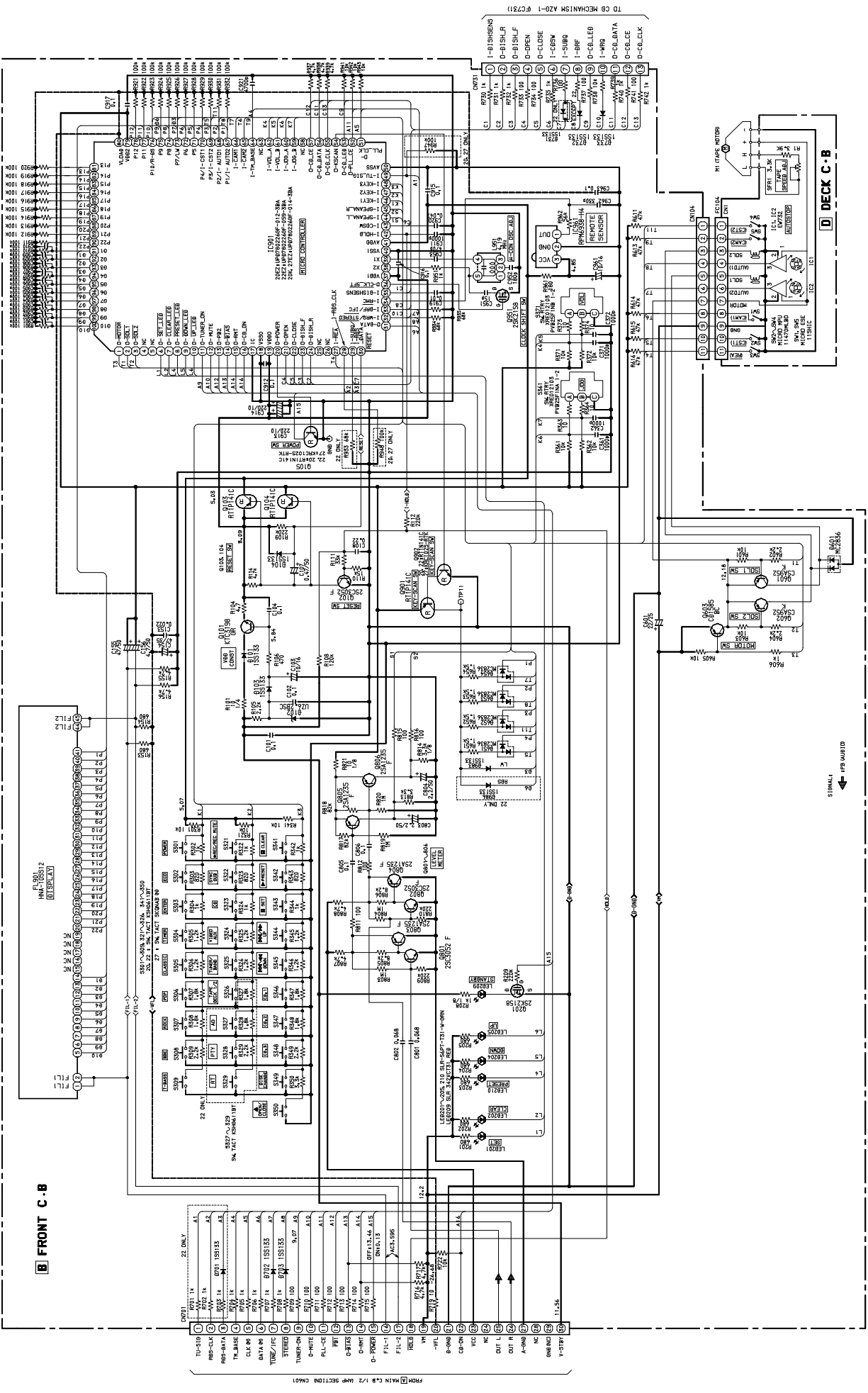

WIRING - 3 (PT)

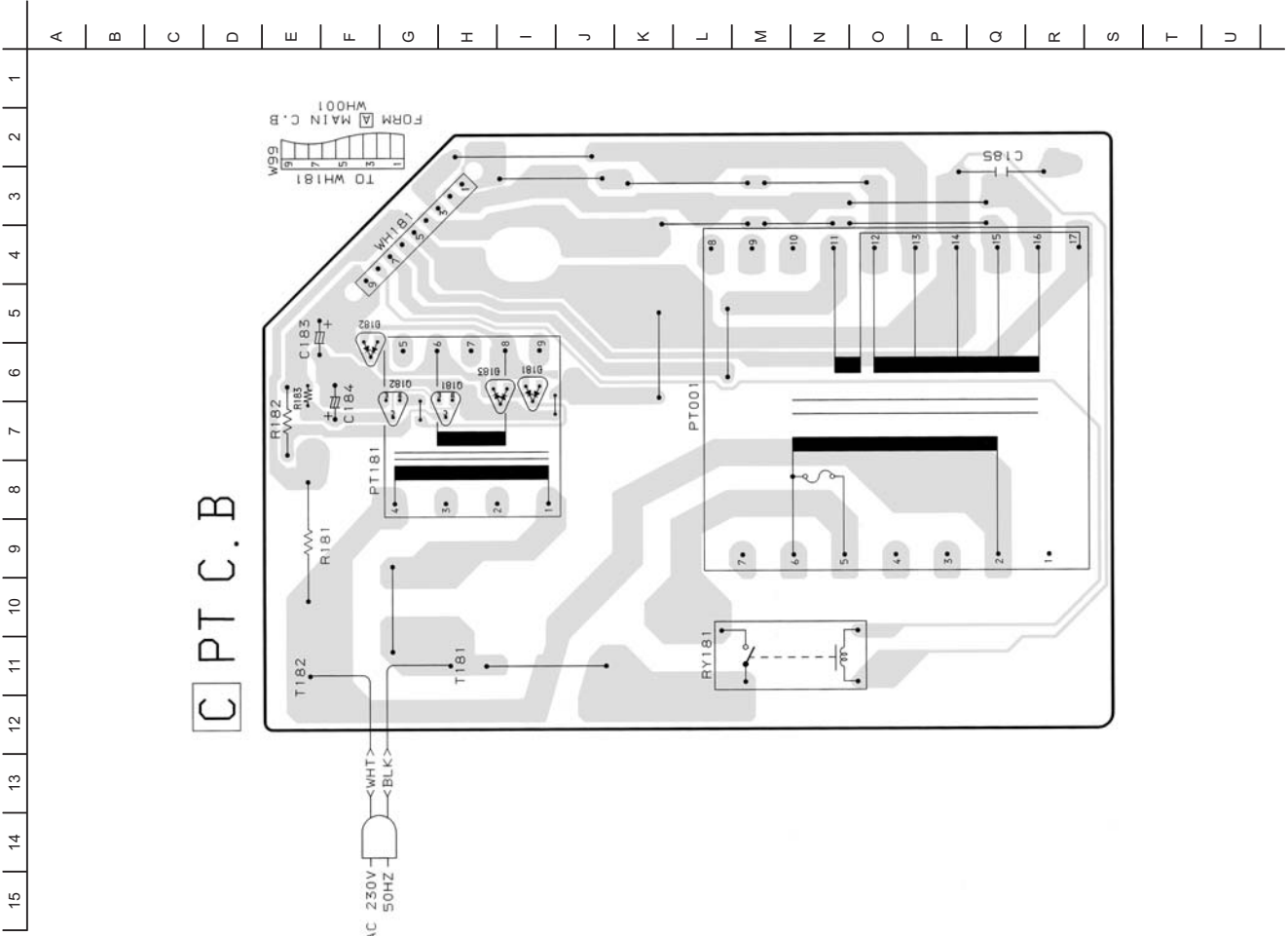

CPT C.B

SCHEMATIC DIAGRAM – 4 (PT)

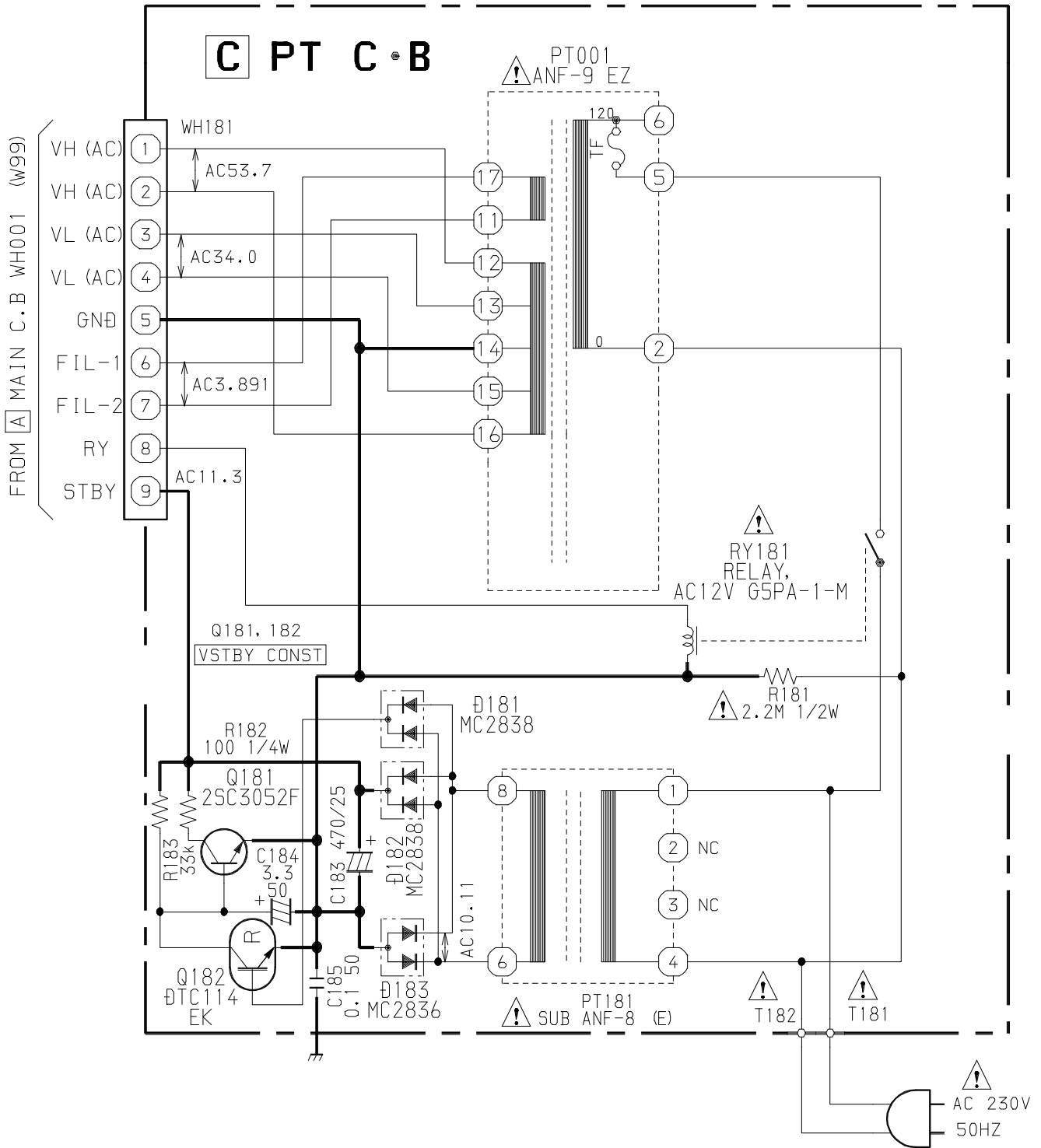

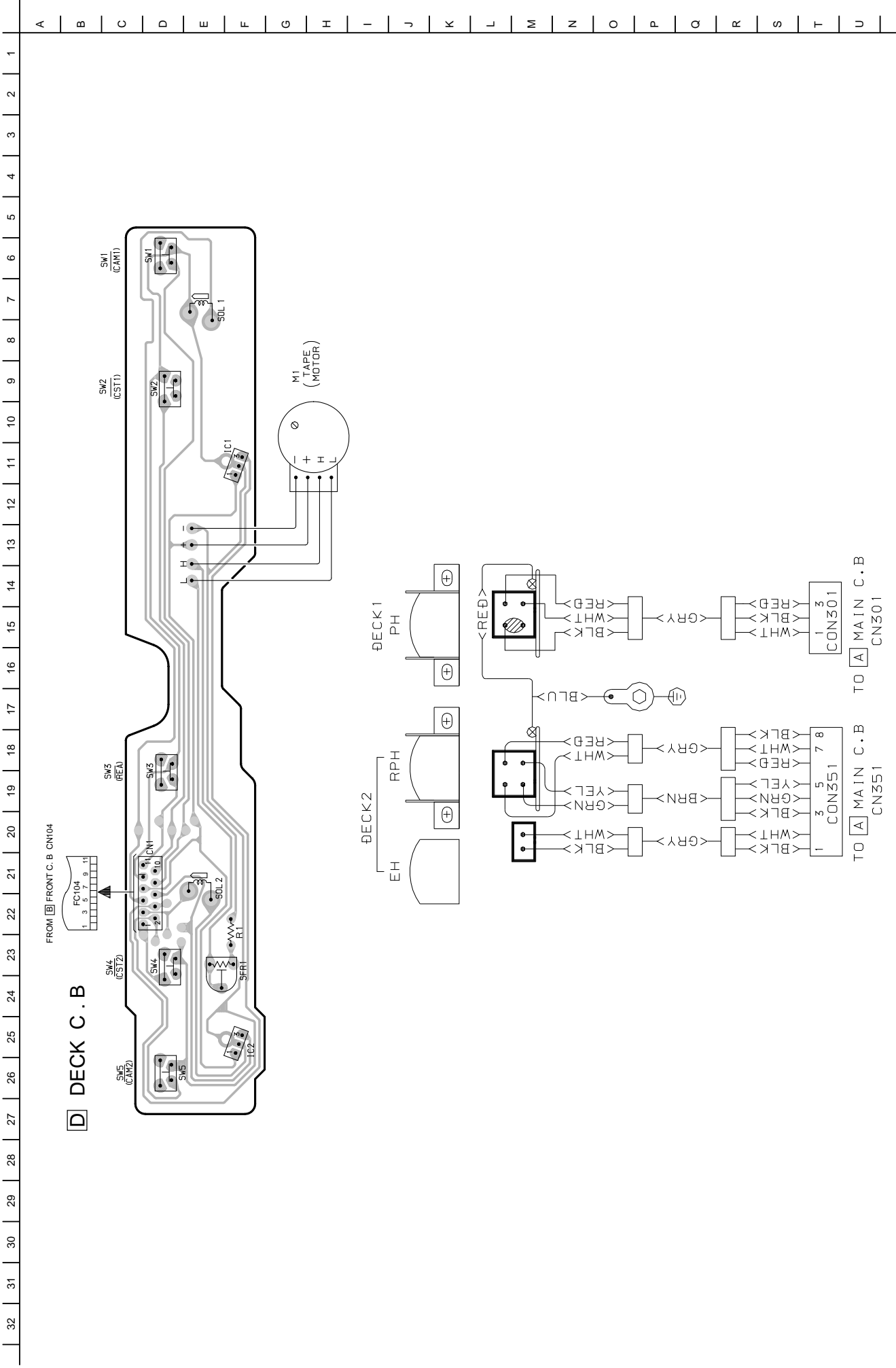

IC BLOCK DIAGRAM

IC, LA1843

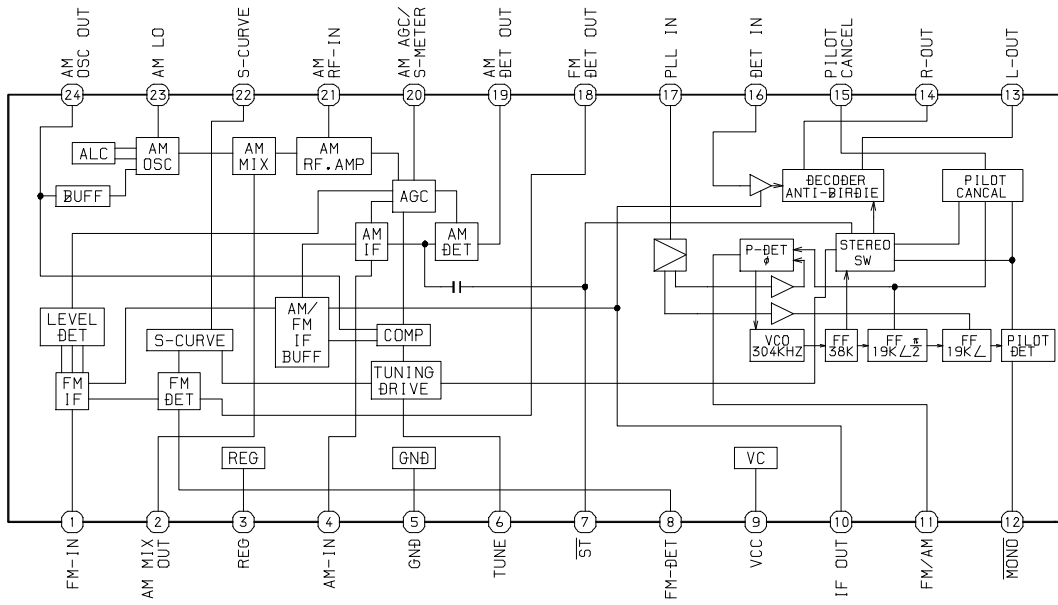

IC, LC72131D

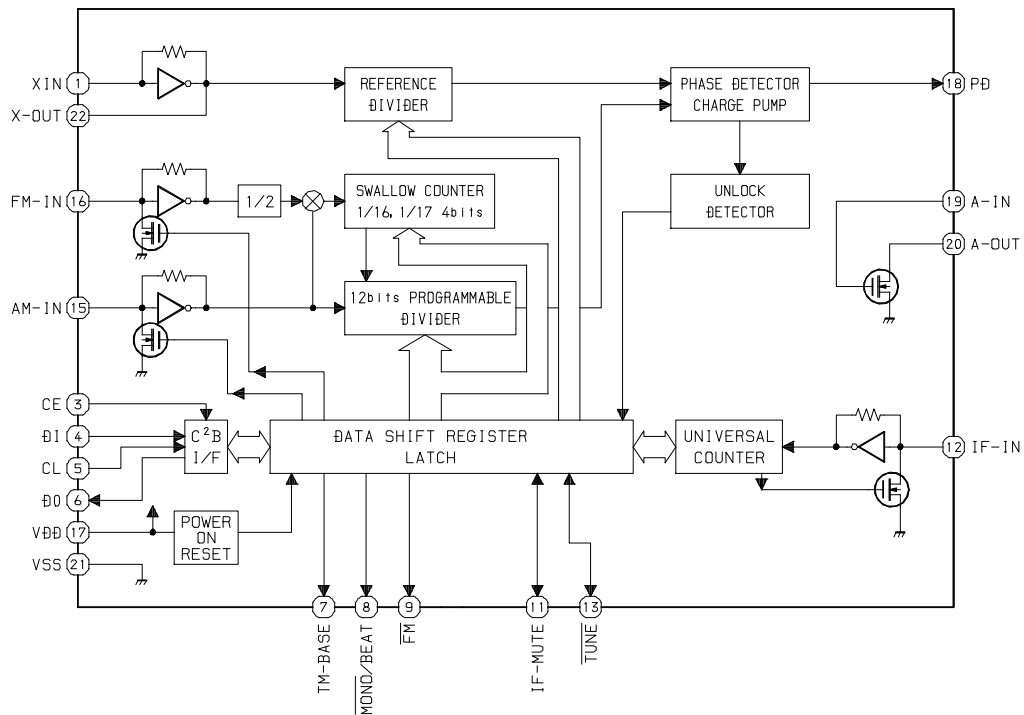

IC, BU1920FS <22EZ ONLY>

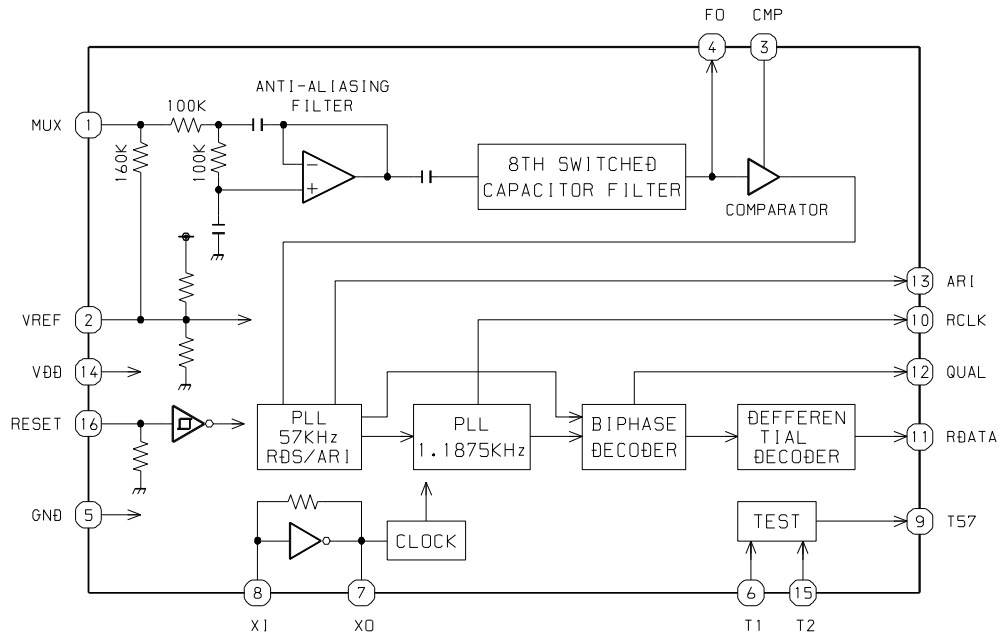

IC, M61503FP

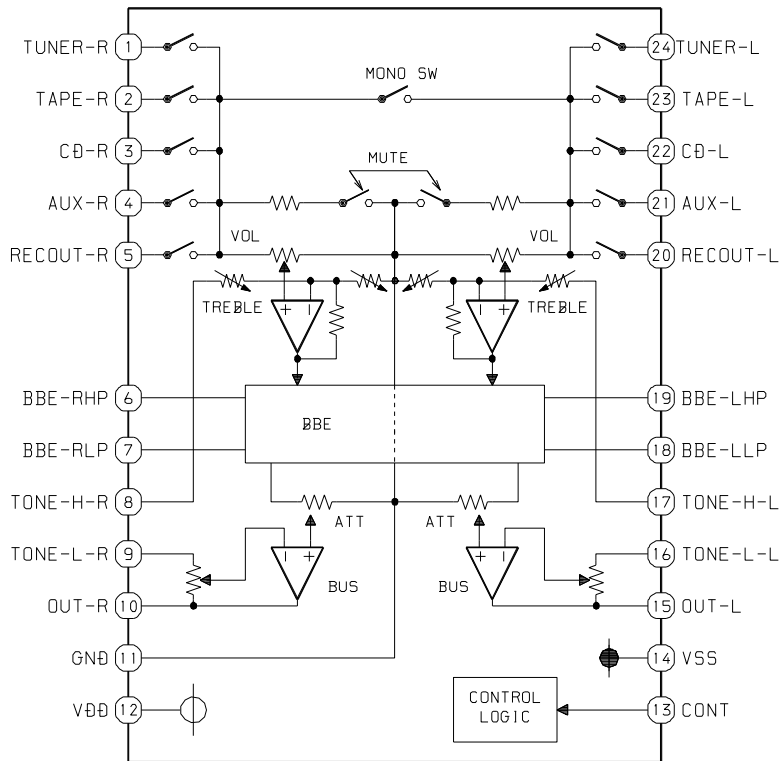

IC DESCRIPTION

IC, μ PD780226GF-012-3BA / 014-3BA / 059-3BA

Pin No.	Pin Name	I/O	Description
1	O-MOTOR	O	DECK MOTOR ON/OFF output.
2	O-SOL1	O	DECK1 solenoid output.
3	O-SOL2	O	DECK2 solenoid output.
4	NC	–	Not connected.
5	NC	–	Not connected.
6	O-SET_LED	O	SET LED ON/OFF output.
7	O-CLEAR_LED	O	CLEAR LED ON/OFF output.
8	O-PRESET_LED	O	PRESET LED ON/OFF output.
9	O-DOWN_LED	O	DOWN LED ON/OFF output.
10	O-UP_LED	O	UP LED ON/OFF output.
11	O-TUNER_ON	O	TUNER ON output.
12	O-MUTE	O	MUTE output.
13	O-PB2	O	DECK2/DECK1 play output.
14	O-BIAS	O	BIAS ON output.
15	O-RMT	O	REC mute output.
16	O-CD_ON	O	CD ON output.
17	IC	–	Internal connection (connected to GND).
18	VSSO	–	GND.
19	VDDO	–	Power supply.
20	O-POWER	O	System power supply ON/OFF output.
21	O-OPEN	O	CD tray open data output.
22	O-CLOSE	O	CD tray close data output.
23	O-DISH_F	O	CD turntable forward rotation output.
24	O-DISH_R	O	CD turntable reverse rotation output.
25	NC	–	Not connected.
26	NC	–	Not connected.
27	I-REA	I	Volume jog AD input.
28	I-RDS_CLK	I	Tuner RDS clock input<22EZ>.
29	I-SUBQ/I-RDS_DATA	I	CD SUBQ data input / Tuner RDS data input<22EZ>.
30	RESET	–	System reset.
31	O-DATA	O	Data output for MAIN.
32	I-WRQ/STEREO	I	CD WRQ input / Tuner stereo input.
33	I-DRF/IFC	I	CD DRF input / Tune IF count serial data input.
34	I-RMC	I	System remote control input.
35	I-DISHSENS	I	CD turntable photo sensor input.
36	O-CLK_SFT	O	Micon clock shift output.
37	VDD1	–	Power supply.
38	X2	–	4.19MHz oscillator circuit.
39	X1	–	4.19MHz oscillator circuit.
40	VSS1	–	GND.
41	AVDD	–	Power supply.
42	I-HOLD	I	Power failure detected input.
43	I-CDSW	I	CD mecha switch input.

Pin No.	Pin Name	I/O	Description
44	I-SPEANA_L	I	A/D L-input for spectrum analyser level display.
45	I-SPEANA_R	I	A/D R-input for spectrum analyser level display.
46	I-KEY1	I	Key1 input.
47	I-KEY2	I	Key2 input.
48	I-KEY3	I	Key3 input.
49	I-TU_SIG	I	Tuner signal input.
50	AVSS	–	GND.
51	O-PLL_CLK	O	PLL clock enable output.
52	O-PLL_CE	O	Chip enable output for tuner PLL.
53	O-CD_LED	O	CD flash window LED ON/OFF output.
54	O-KSCAN	O	Key scan output.
55	O-CD_CLK	O	CD clock output.
56	O-CD_DATA	O	CD data output.
57	O-CD_CE	O	CD enable output.
58	NC	–	Not connected.
59	I-JOG_B	I	Dial jog rotary encoder input B.
60	I-JOG_A	I	Dial jog rotary encoder input A.
61	I-VOL_B	I	Volume rotary encoder input B.
62	I-VOL_A	I	Volume rotary encoder input A.
63	NC	–	Not connected.
64	I-TM_BASE	I	Base input for clock.
65	I-CAM2	I	DECK2 CAM switch data input.
66	I-CAM1	I	DECK1 CAM STOP switch data input.
67	P1/I-AUTO2	O/I	FL segment P1 output / DECK2 AUTO STOP switch data input.
68	P2/I-AUTO1	O/I	FL segment P2 output / DECK1 AUTO STOP switch data input.
69	P3/I-CST2	O/I	FL segment P3 output / DECK2 cassette detect switch data input.
70	P4/I-CST1	O/I	FL segment P4 output / DECK1 cassette detect switch data input.
71, 72	P5, P6	O	FL segment P5, P6 output.
73	P7/LW	O/I	FL segment P7 output / LW mode data input.
74, 75	P8, P9	O	FL segment P8, P9 output.
76	P10/RDS	O/I	FL segment P10 output / RDS data input<22EZ>.
77, 78	P11, P12	O	FL segment P11, P12 output.
79	VDD2	–	Power supply.
80	VLOAD	–	Power supply for FL display.
81	P13/C-JACK	O/I	FL segment P13 output / C-JACK data input.
82	P14/ECO-OFF	O/I	FL segment P14 output / ECO-OFF data input.
83 ~ 90	P15 ~ P22	O	FL segment P15 ~ P22 output.
91 ~100	G1 ~ G10	O	FL grid G1 ~ G10 output.

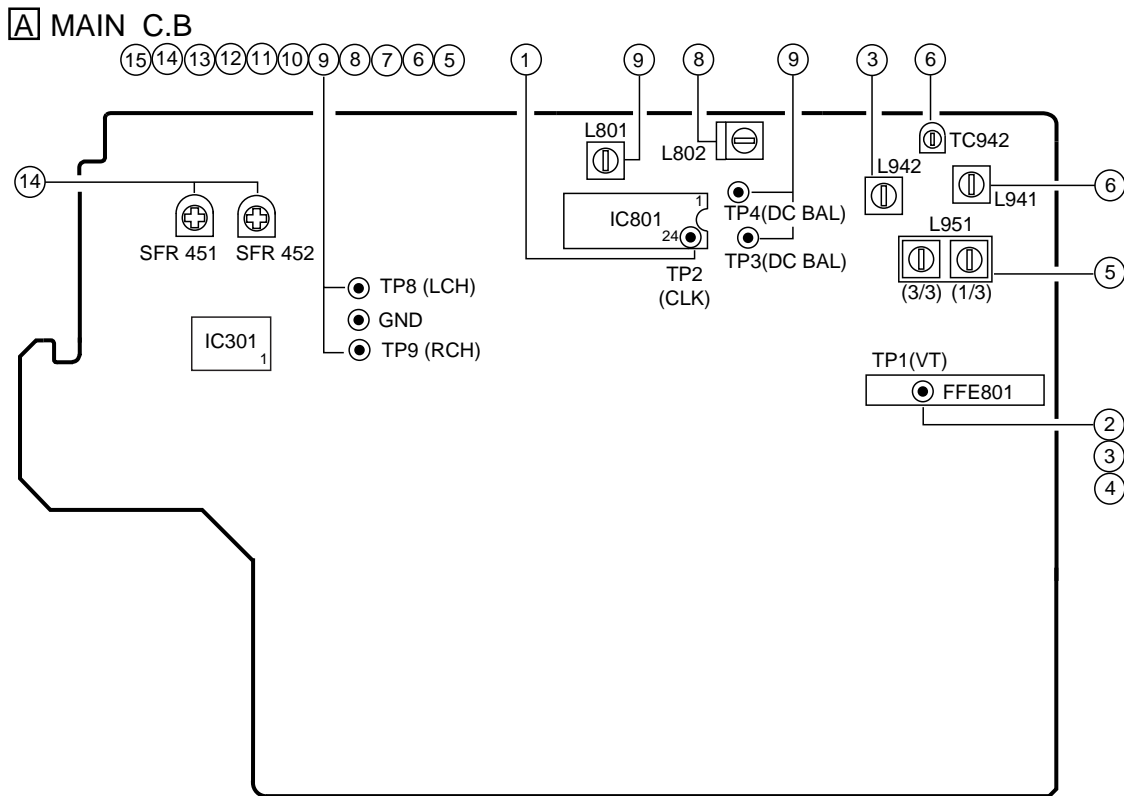

< TUNER SECTION >

1. Clock frequency Check
 Settings : • Test point : TP2 (CLK)
 Method : Set to MW 1602kHz and check that the test point is 2052kHz \pm 45Hz.
2. MW VT Check
 Settings : • Test point : TP1 (VT)
 Method : Set to MW 1602kHz, 531kHz and check that the test point is less than 8.0V (1602kHz) and more than 0.6V (531kHz).
3. LW VT Adjustment
 Settings : • Test point : TP1 (VT)
 • Adjustment location : L942
 Method : Set to LW 144kHz and adjust L942 so that the test point becomes 1.3V \pm 0.05V. Then set to LW 290kHz and check that the test point is less than 8.0V.
4. FM VT Check
 Settings : • Test point : TP1 (VT)
 Method : Set to FM 87.5MHz, 108.0MHz and check that the test point is more than 0.5V (87.5MHz) and less than 8.0V (108.0MHz).
5. MW Tracking Adjustment
 Settings : • Test point : TP8(Lch), TP9(Rch)
 • Adjustment location :
 L951(1/3) 1000kHz
 Method : Set to MW 1000kHz and adjust L951(1/3) to MAX.
6. LW Tracking Adjustment
 Settings : • Test point : TP8 (Lch), TP9 (Rch)
 • Adjustment location :
 L941144kHz
 TC942290kHz
 Method : Set up TC942 to center before adjustment.
 Adjust L941 so that the level at 144kHz becomes maximum. Then adjust TC942 so that the level at 290kHz becomes maximum.
7. FM Tracking Check
 Settings : • Test point : TP8(Lch), TP9(Rch)
 Method : Set to FM 98.0MHz and check that the test point is less than 13dB μ V.
8. AM IF Adjustment
 Settings : • Test point : TP8(Lch), TP9(Rch)
 • Adjustment location :
 L802 450kHz
9. DC Balance / Mono Distortion Adjustment
 Settings : • Test point : TP3, TP4 (DC Balance)
 TP8(Lch), TP9(Rch) (Distortion)
 • Adjustment location : L801
 • Input level : 60dB μ V
 Method : Set to FM 98.0MHz and adjust L801 so that the voltage between TP3 and TP4 becomes 0V \pm 0.04V.
 Next, check that the distortion is less than 1.3%.

B FRONT C.B

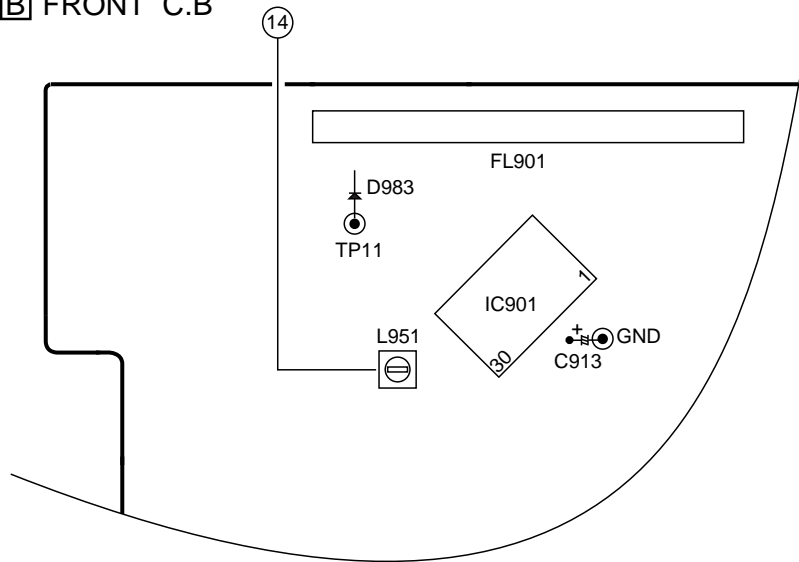

D DECK C.B

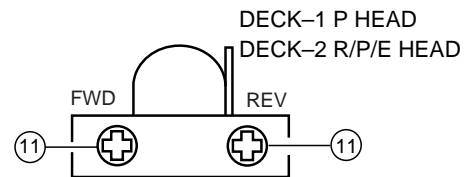
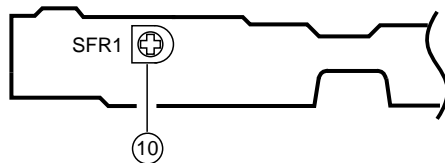

< DECK SECTION >

10. Tape Speed Adjustment (DECK 2)

- Settings : • Test tape : TTA-100
 • Test point : TP8(Lch), TP9(Rch)
 • Adjustment location : SFR1

Method : Play back the test tape and adjust SFR1 so that the frequency counter reads $3000\text{Hz} \pm 5\text{Hz}$ and $\pm 45\text{Hz}$ (REV) with respect to forward speed.

11. Head Azimuth Adjustment (DECK 1, DECK 2)

- Settings : • Test tape : TTA-330
 • Test point : TP8(Lch), TP9(Rch)
 • Adjustment location : Azimuth adjustment screw

Method : Play back (FWD) the 8kHz signal of the test tape and adjust screw so that the output becomes maximum. Next, perform on REV PLAY mode.

12. PB Frequency Response Check (DECK 1, DECK 2)

- Settings : • Test tape : TTA-330
 • Test point : TP8(Lch), TP9(Rch)

Method : Play back the 315Hz and 8kHz signals of the test tape and check that the output ratio of the 8kHz signal with respect to that of the 315Hz signal is within 5dB.

13. PB Sensitivity Check (DECK 1, DECK 2)

- Settings : • Test tape : TTA-200
 • Test point : TP8(Lch), TP9(Rch)

Method : Play back the test tape and check that the output level of the test point is $110\text{mV} \pm 3\text{dB}$.

14. REC/PB Frequency Response Adjustment (DECK 2)

- Settings : • Test tape : TTA-602
 • Test point : TP8(Lch), TP9(Rch)
 • Input signal : 1kHz / 8kHz (LINE IN)
 • Adjustment location : SFR451 (Lch)
 SFR452 (Rch)

Method : Apply a 1kHz signal and REC mode. Then adjust OSC attenuator so that the output level at the TP8, TP9 becomes -20VU (-26dBV). Record and play back the 1kHz and 8kHz signals and adjust SFRs so that the output of the 8kHz signals becomes $0\text{dB} \pm 0.5\text{dB}$ with respect to that of the 1kHz signal.

15. REC/PB Sensitivity Check (DECK 2)

- Settings : • Test tape : TTA-602
 • Test point : TP8(Lch), TP9(Rch)
 • Input signal : 1kHz (LINE IN)

Method : Apply a 1kHz signal and REC mode. Then adjust OSC attenuator so that the output level at TP8, TP9 becomes 0VU (-6dBV). Record and play back the 1kHz signals and check that the output is $-1\text{dB} \pm 3.5\text{dB}$.

16. μ -con OSC Adjustment

- Settings : • Test point : TP11, GND
 • Adjustment location : L951

Method : Insert AC plug while pressing TUNER function key. Adjust L951 so that the frequency across the test point becomes $184.98\text{Hz} \pm 0.18\text{Hz}$.

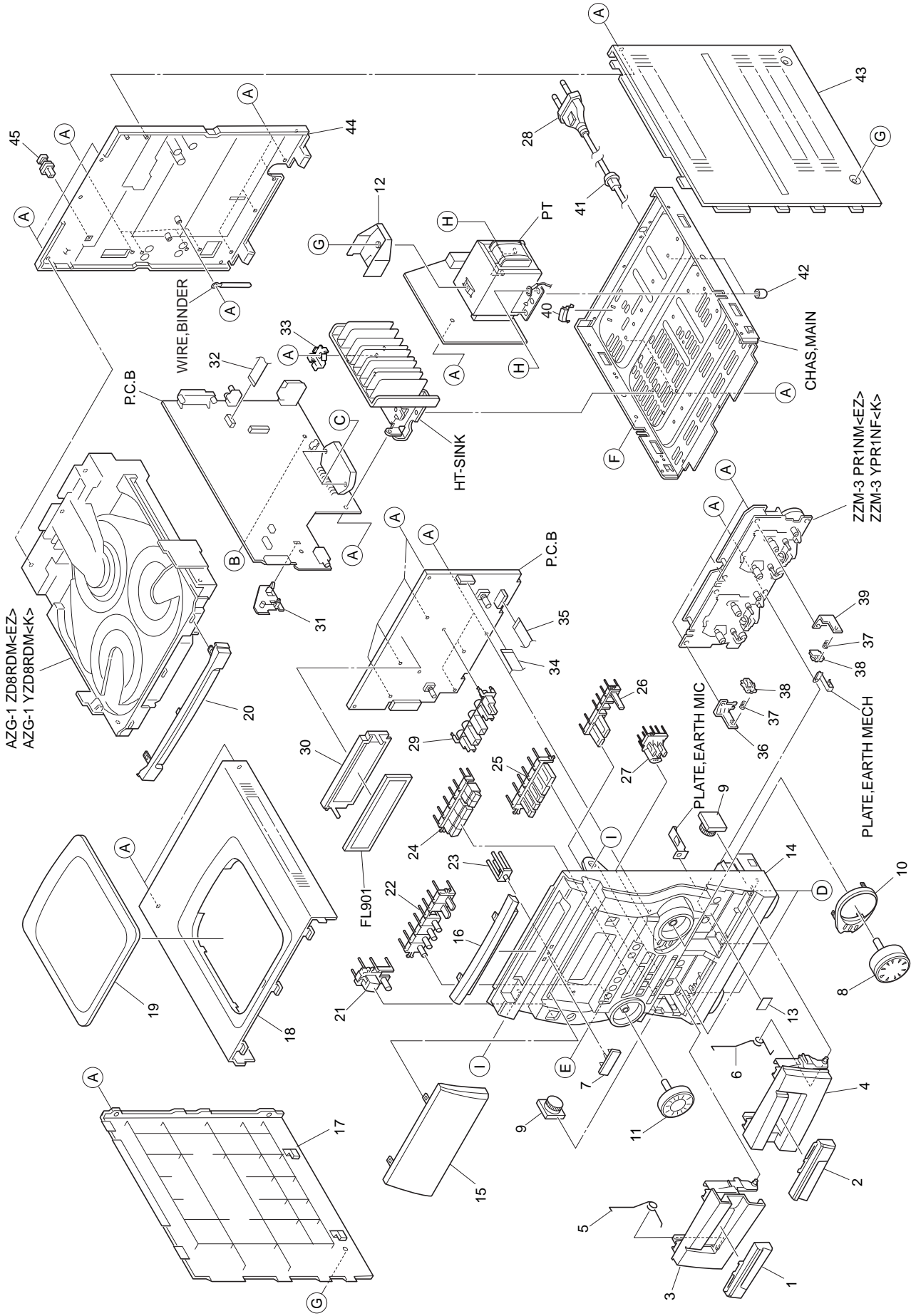

MECHANICAL PART LIST 1 / 1

REF. NO.	PART NO.	KANRI NO.	DESCRIPTION	REF. NO.	PART NO.	KANRI NO.	DESCRIPTION
1	8A-NF9-006-010		WINDOW, CASS 1<EXCEPT 27>	26	8A-NF9-050-010		KEY, RDS<22>
1	8A-NF9-085-010		WINDOW, CASS 1 B<27>	26	8A-NF9-019-010		KEY, SYNC<EXCEPT 22>
2	8A-NF9-007-010		WINDOW, CASS 2<EXCEPT 27>	27	8A-NF9-026-110		KEY, ENTER
2	8A-NF9-086-010		WINDOW, CASS 2 B<27>	△ 28	87-A80-157-010		AC CORD ASSY, E BLK CC
3	8A-NF9-003-010		BOX, CASS 1<EXCEPT 27>	29	8A-NF9-201-010		GUIDE, OPE 1 WAY
3	8A-NF9-082-010		BOX, CASS 1 B<27>	30	82-NF7-210-110		GUIDE, FL (*)
4	8A-NF9-004-010		BOX, CASS 2<EXCEPT 27>	31	8A-NF8-206-010		HLDR, PWB M
4	8A-NF9-083-010		BOX, CASS 2 B<27>	32	88-906-251-110		FF-CABLE, 6P 1.25
5	8A-NF8-207-010		SPR-T, EJECT 1	33	8A-NF8-205-010		HLDR, IC
6	8A-NF8-208-010		SPR-T, EJECT 2	34	88-913-301-110		FF-CABLE, 13P-1.25
7	87-CE3-023-010		BADGE, AIWA 30N SILV	35	88-911-101-110		FF-CABLE, 11P 1.25
8	8A-NF9-018-010		KNOB, RTRY JOG	36	87-NF4-216-010		HLDR, LOCK 1
9	8A-NF8-209-010		OIL-DMPR, 120	37	86-NF9-224-010		SPR-C, LOCK
10	8A-NF9-017-010		PANEL, JOG	38	82-NF5-229-010		PLATE, LOCK
11	8A-NF9-016-010		KNOB, RTRY VOL	39	87-NF4-217-110		HLDR, LOCK 2
12	8A-NF9-211-010		HLDR, PWB PT HI	40	87-NF4-221-010		HLDR, CABLE
13	81-532-080-010		LABEL, CASS. COMPT	41	87-085-185-010		BUSHING, AC CORD (E)
14	8A-NF9-049-010		CABI, FR EZ R<22>	42	8Z-NB8-240-010		COVER, PL
14	8A-NF9-081-010		CABI, FR EZB<27>	43	8A-NF8-008-010		PANEL, RIGHT V-2<EXCEPT 27>
14	8A-NF9-001-010		CABI, FR U<20>	43	8A-NF9-093-010		PANEL, RIGHT V-2 B<27>
15	8A-NF9-044-010		WINDOW, DISP EZ RDS<22>	44	8A-NF9-094-010		CABI, REAR EZBM<27>
15	8A-NF9-084-010		WINDOW, DISP EZB Z27<27>	44	8A-NF9-059-110		CABI, REAR EZSM<20EZ>
15	8A-NF9-052-010		WINDOW, DISP LH<20EZ>	44	8A-NF9-058-110		CABI, REAR EZSM R<22>
15	8A-NF9-005-010		WINDOW, DISP U<20K>	44	8A-NF9-035-010		CABI, REAR KSE<20K>
16	8A-NF9-039-010		WINDOW, CD<EXCEPT 27>	45	84-ZG1-245-210		CAP, OPTICAL
16	8A-NF9-089-010		WINDOW, CD B<27>	A	87-067-703-010		TAPPING SCREW, BVT2+3-10
17	8A-NF8-007-010		PANEL, LEFT V-2<EXCEPT 27>	B	87-NF4-224-010		S-SCREW, IT3B+3-8 CU
17	8A-NF9-092-010		PANEL, LEFT V-2 B<27>	C	87-067-581-010		TAPPING SCREW, BVT2+3-15
18	8A-NF8-005-010		PANEL, TOP<EXCEPT 27>	D	87-067-689-010		TAPPING SCREW, BVT+3-8
18	8A-NF9-090-010		PANEL, TOP B<27>	E	87-723-096-410		QT2+3-10W/O SLOT BL
19	8A-NF8-006-010		WINDOW, TOP<EXCEPT 27>	F	87-721-096-410		QT2+3-10 GLD
19	8A-NF9-091-010		WINDOW, TOP B<27>	G	87-067-641-010		UTT2+3-8 (W/O SLOT) BL
20	8A-NF9-014-010		PANEL, TRAY<EXCEPT 27>	H	87-078-191-010		S-SCREW, IT+4-10
20	8A-NF9-088-010		PANEL, TRAY B<27>	I	87-721-097-410		QT2+3-12 GLD
21	8A-NF9-008-010		KEY, POWER<EXCEPT 27>				
21	8A-NF9-087-010		KEY, POWER B<27>				
22	8A-NF9-009-010		KEY, FUN				
23	8A-NF9-022-010		REFLECTOR, ECO				
24	8A-NF9-010-110		KEY, ASSY OPE 1 WAY				
25	8A-NF9-020-010		KEY, CD				

COLOR NAME TABLE

Basic color symbol	Color	Basic color symbol	Color	Basic color symbol	Color
B	Black	C	Cream	D	Orange
G	Green	H	Gray	L	Blue
LT	Transparent Blue	N	Gold	P	Pink
R	Red	S	Silver	ST	Titan Silver
T	Brown	V	Violet	W	White
WT	Transparent White	Y	Yellow	YT	Transparent Yellow
LM	Metallic Blue	LL	Light Blue	GT	Transparent Green
LD	Dark Blue	DT	Transparent Orange	GM	Metallic Green
YM	Metallic Yellow	DM	Metallic Orange		

TAPE MECHANISM EXPLODED VIEW 1 / 1

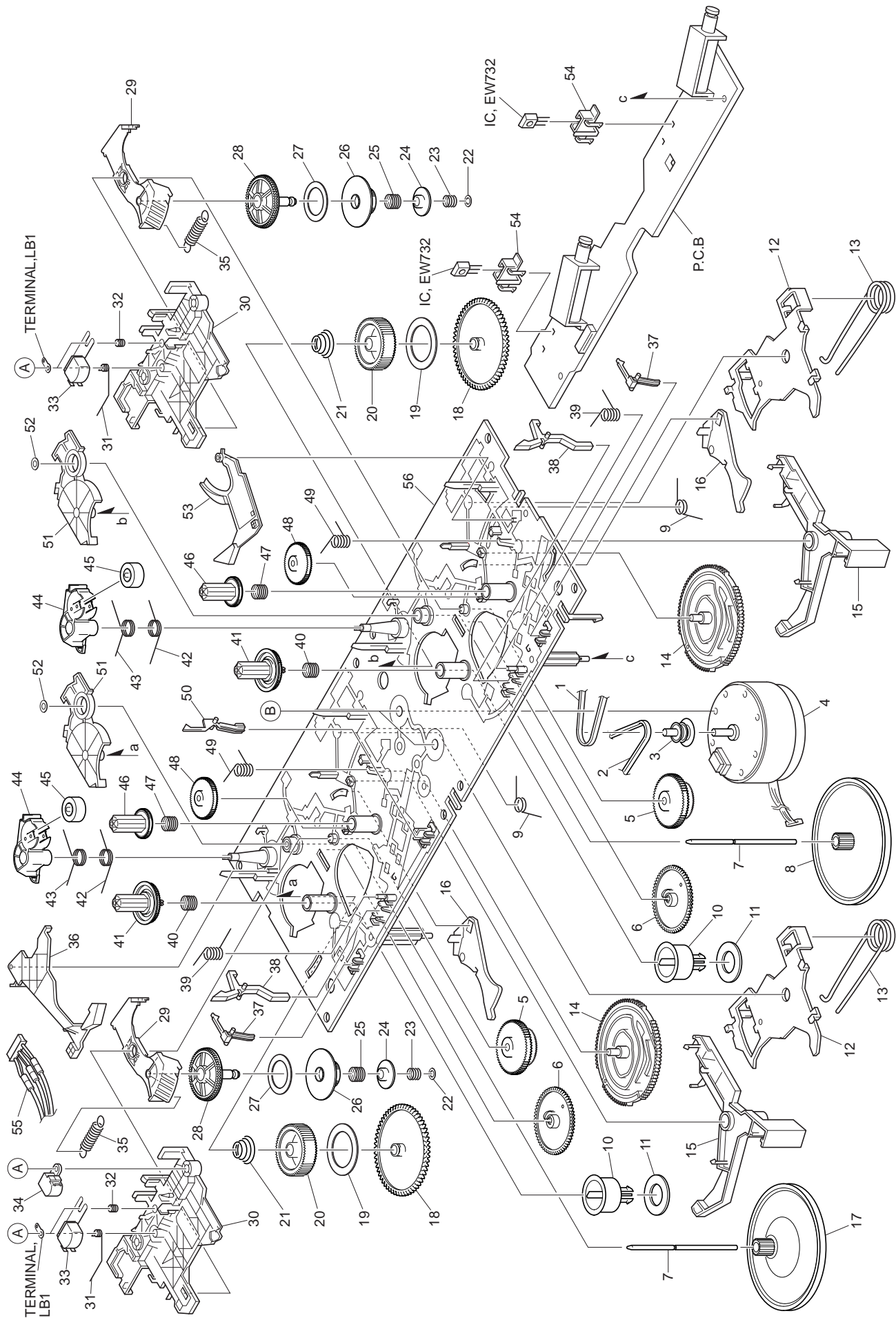

TAPE MECHANISM PART LIST 1 / 1

REF. NO.	PART NO.	KANRI NO.	DESCRIPTION	REF. NO.	PART NO.	KANRI NO.	DESCRIPTION
1	8Z-ZM3-227-010	0E	BELT, MAIN M3	31	8Z-ZM3-233-010	0E	SPR-T, BRG M3
2	8Z-ZM3-235-010	0E	BELT, MAIN L	32	84-ZM2-227-310	0E	SPR-C, AZIMUTH
3	8Z-ZM1-235-010	0E	PULLEY, MOT	33	87-A90-403-110	1B	HEAD, RPH MS15R
4	87-045-347-010	1H	MOT, SHU2L 70	34	87-A90-404-010	1B	HEAD, EH LE15B
5	8Z-ZM1-232-010	0E	GEAR, IDL FF/REW	35	8Z-ZM3-239-010	0E	SPR-E, FR
6	8Z-ZM3-244-010	0E	GEAR, CAM TD20	36	8Z-ZM3-211-010	0E	LEVER, EJECT R
7	8Z-ZM3-242-010	0E	SHAFT, CAP M3	37	8Z-ZM3-225-010	0E	LEVER, STOP
8	8Z-ZM3-228-010	0E	FLY-WHL, M3	38	8Z-ZM3-221-010	0E	LEVER, CAS
9	8Z-ZM3-231-010	0E	SPR-T, TRIG	39	8Z-ZM3-234-010	0E	SPR-T, LVR CAS
10	8Z-ZM3-213-010	0E	CLR, MG	40	8Z-ZM3-223-010	0E	SPR-C, REEL R M3
11	82-ZM3-616-010	0E	RING MAGNET 4	41	8Z-ZM1-225-110	0E	GEAR, REEL R
12	8Z-ZM3-243-010	0E	LEVER ASSY, HD UP	42	8Z-ZM3-240-010	0E	SPR-T, T-UP M3
13	8Z-ZM3-238-010	0E	SPR-T, HD UP	43	8Z-ZM3-237-010	0E	SPR-T, PINCH M3
14	8Z-ZM3-219-010	0E	GEAR, CAM M3	44	8Z-ZM3-215-010	0E	LEVER, PINCH M3
15	8Z-ZM3-206-010	0E	LEVER, TRIG	45	8Z-ZM1-261-110	0E	ROLLER ASSY, PINCH
16	8Z-ZM3-209-010	0E	LEVER, CAM FR	46	8Z-ZM1-226-010	0E	GEAR, REEL L
17	8Z-ZM2-211-010	0E	FLY-WHL, ZZM-2	47	8Z-ZM3-222-010	0E	SPR-C, REEL L M3
18	8Z-ZM1-228-010	0E	GEAR, SLIP T-UP B	48	8Z-ZM3-251-010	0E	GEAR, IDL REW M3
19	8Z-ZM1-265-010	0E	FELT, T-UP	49	8Z-ZM3-236-010	0E	SPR-T, PLAY M3
20	8Z-ZM1-227-010	0E	GEAR, SLIP T-UP A	50	82-ZM1-240-110	0E	LVR, REC(*)
21	8Z-ZM1-251-110	0E	SPR-C, T-UP SLIP	51	8Z-ZM3-216-010	0E	LEVER, T-UP M3
22	8Z-ZM1-275-010	0E	W-L, 1, 47-4-0.25	52	87-B10-301-010	0E	W-L, 1.63-3.2-05 SLIT
23	8Z-ZM1-257-010	0E	SPR-C, F/R	53	8Z-ZM3-212-010	0E	LEVER, EJECT L
24	8Z-ZM1-236-010	0E	CLR, SLIP FF/REW	54	8Z-ZM3-214-010	0E	HLDR, IC
25	8Z-ZM3-226-010	0E	SPR-C, FR M3	55	86-ZM3-605-110	1B	CONN ASSY, 8P -RPB
26	8Z-ZM3-250-010	0E	GEAR, SLIP F/R A M3	56	8Z-ZM3-203-010	1H	CHAS ASSY, M3
27	8Z-ZM1-269-010	0E	FELT, FF/REW 2	A	84-ZM2-242-010	0E	S-SCREW, AZ1-2-6.4
28	8Z-ZM1-238-110	0E	GEAR, SLIP FF/REW B 2	B	8Z-ZM2-220-110	0E	V+2.6 ZZM-2
29	8Z-ZM3-220-010	0E	LEVER, FR M3				
30	8Z-ZM3-205-010	0E	LEVER, PLAY M3				

SPEAKER DISASSEMBLY INSTRUCTIONS

Type.1

Insert a flat-bladed screwdriver into the position indicated by the arrows and remove the panel. Remove the screws of each speaker unit and then remove the speaker units.

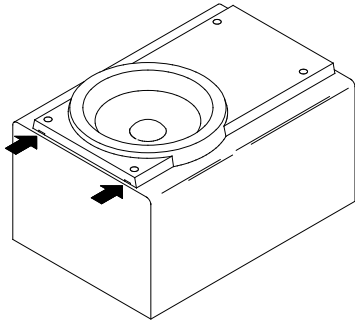

Type.2

Remove the grill frame and four pieces of rubber caps by pulling out with a flat-bladed screwdriver. Remove the screws from hole where installed rubber caps. Insert a flat-bladed screwdriver into the position indicated by the arrows and remove the panel. Remove the screws of each speaker unit and then remove the speaker units.

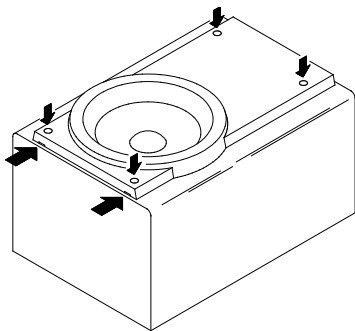

Type.3

Insert a flat-bladed screwdriver into the position indicated by the arrows and remove the panel. Turn the speaker unit to counter-clockwise direction while inserting a flat-bladed screwdriver into one of the hollows around speaker unit, and then remove the speaker unit. After replacing the speaker unit, install it turning to clockwise direction until "click" sound comes out.

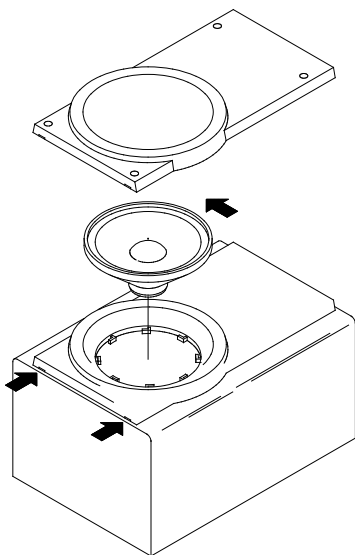

Type.4

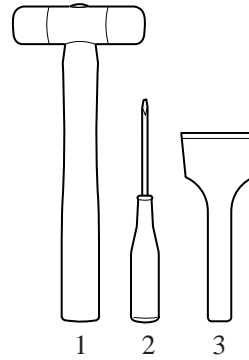

TOOLS

- 1 Plastic head hammer
- 2 flat head screwdriver
- 3 Cut chisel

How to Remove the PANEL, FR

1. Insert the flat head screwdriver tip into the gap between the PANEL, FR and the PANEL, SPKR. Tap the head of the flat head screwdriver with the plastic hammer head, and create the clearance as shown in Fig-1.
2. Insert the cut chisel in the clearance, and tap the head of the cut chisel with plastic hammer as shown in Fig-2, to remove the PANEL, FR.
3. Place the speaker horizontally. Tap head of the cut chisel with plastic hammer as shown in Fig-3, and remove the PANEL, FR completely.

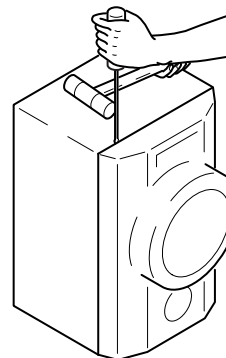

Fig-1

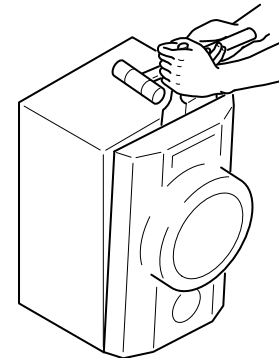

Fig-2

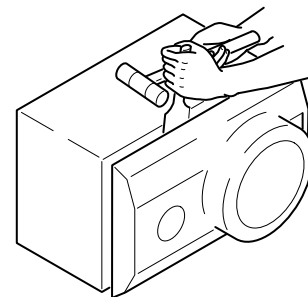

Fig-3

How to Attach the PANEL, FR

Attach the PANEL, FR to the PANEL, SPKR. Tap the four corners of the PANEL, FR with the plastic hammer to fit the PANEL, FR into the PANEL, SPKR completely.

SPEAKER PARTS LIST

SX-NSZ20 (YBC9,YBY1,YBY2,YSL,YSC9,YSY1,YSY2), SX-NSZ22 (YSC9,YSY1,YSY2)

REF.NO.	PART NO.	KANRI NO.	DESCRIPTION
1	8A-NSK-001-010		PANEL,FR<EXCEPT YBC9,YBY1,YBY2>
2	8A-NSK-003-010		GRILLE,FRAME ASSY
3	8A-NSK-007-010		PROTECTOR,TWA
4	8A-NSK-602-010		SPKR,W 140<EXCEPT 22YSC9>
4	8A-NSJ-602-010		SPKR,W 130<22YSC9>
5	88-NS5-605-010		SPKR,T 60<EXCEPT 22YSC9>
5	8A-NSK-604-010		SPKR,TW 60<22YSC9>
6	87-NSH-612-010		SPKR,CERAMIC ASSY
7	87-NS7-611-010		CORD,SPKR

ACCESSORIES / PACKAGE LIST

REF.NO.	PART NO.	KANRI NO.	DESCRIPTION
1	8A-NF9-926-010		IB,EZ(9L)M<20EZ,27EZ>
1	8A-NF9-927-010		IB,EZ(9L)M SZ22(RDS)<22EZ>
1	8A-NF9-905-010		IB,K(E)E<20K>
2	87-A90-118-010		ANT,WIRE FM(Z)
3	87-006-225-010		AM,LOOP ANT NC2
4	8Z-NF9-701-210		RC UNIT,ZAS02<20EZ,20K,22EZ>
4	8Z-NF9-703-110		RC UNIT,ZAS17<27EZ>



アイワ株式会社 〒110-8710 東京都台東区池之端1-2-11 ☎03(3827)3111 (代表)
AIWA CO.,LTD. 2-11, IKENOHATA 1-CHOME, TAITO-KU, TOKYO 110, JAPAN TEL:03 (3827) 3111
