

# SERVICE MANUAL

COMPACT DISC  
STEREO SYSTEM

BASIC TAPE MECHANISM : 6ZM-3 PR2NM  
BASIC CD MECHANISM : AZG-1 ZA3RDM

SYSTEM	CD CASSEIVER	SPEAKER	REMOTE CONTROLLER
NSX-SZ40	CX-NSZ40	SX-NSZ51	RC-ZAS01
NSX-SZ42	CX-NSZ42	SX-NSZ53	

- If requiring information about the CD mechanism, see Service Manual of AZG-1, (S/M Code No. 09-001-335-3NC).

# SPECIFICATIONS

## Main unit CX-NSZ40, CX-NSZ42

### FM tuner section

<b>Tuning range</b>	87.5 MHz to 108 MHz
<b>Usable sensitivity (IHF)</b>	16.8 dBf
<b>Antenna terminal</b>	75 ohms (unbalanced)

### AM (MW) tuner section

<b>Tuning range</b>	531 kHz to 1602 kHz (9 kHz step) 530 kHz to 1710 kHz (10 kHz step)
---------------------	---

<b>Usable sensitivity</b>	350 $\mu$ V/m
<b>Antenna</b>	Loop antenna

### LW tuner section

<b>Tuning range</b>	144 kHz to 290 kHz
<b>Usable sensitivity</b>	1400 $\mu$ V/m
<b>Antenna</b>	Loop antenna

### Amplifier section

<b>Power output</b>	Rated: 80 W + 80 W (6 ohms, T.H.D. 1 %, 1 kHz/DIN 45500) Reference: 100 W +100 W (6 ohms, T.H.D. 10 %, 1 kHz/DIN 45324) DIN MUSIC POWER: 200 W + 200 W
---------------------	---

<b>Total harmonic distortion</b>	0.1 % (45 W, 1 kHz, 6 ohms, DIN AUDIO)
----------------------------------	---

### Inputs

VIDEO/AUX: 500 mV

### Outputs

**SPEAKERS:**  
accept speakers of 6 ohms or more  
**SURROUND SPEAKERS:**  
accept speakers of 8 ohms to 16  
ohms  
**PHONES (stereo jack):** accepts  
headphones of 32 ohms or more

## Cassette deck section

<b>Track format</b>	4 tracks, 2 channels stereo
<b>Frequency response</b>	50 Hz – 15000 Hz
<b>Recording system</b>	AC bias
<b>Heads</b>	Deck 1: Playback head x 1 Deck 2: Recording/playback head x 1, erase head x 1

## Compact disc player section

<b>Laser</b>	Semiconductor laser ( $\lambda = 780$ nm)
<b>D-A converter</b>	1 bit dual
<b>Signal-to-noise ratio</b>	85 dB (1 kHz, 0 dB)
<b>Harmonic distortion</b>	0.05 % (1 kHz, 0 dB)
<b>Wow and flutter</b>	Unmeasurable

## General

<b>Power requirements</b>	230 V AC, 50 Hz
<b>Power consumption</b>	150 W
<b>Power consumption in standby mode</b>	If the power-economizing mode is ECO OFF: 20 W If the power-economizing mode is ECO ON or ECO AUTO: 0.9 W

<b>Dimensions of main unit (W x H x D)</b>	260 x 326 x 345 mm
--	--------------------

<b>Weight of main unit</b>	8.3 kg
----------------------------	--------

## Speaker system SX-NSZ51, SX-NSZ53

<b>Speaker system</b>	3 way, Bass reflex (magnetic shielded type)
<b>Speaker units</b>	Woofer: 140 mm cone type Tweeter: 60 mm cone type Super tweeter: 20 mm ceramic type

<b>Impedance</b>	6 ohms
<b>Sensitivity</b>	87 dB/W/m
<b>Dimensions (W x H x D)</b>	240 x 324 x 270 mm
<b>Weight</b>	4.0 kg

- Design and specifications are subject to change without notice.
- The word "BBE" and the "BBE symbol" are trademarks of BBE Sound, Inc.
- Under license from BBE Sound, Inc.

## ACCESSORIES LIST

DESCRIPTIONで判断できない物は "REFERENCE NAME LIST" を参照してください。  
If can't understand for Description please kindly refer to "REFERENCE NAME LIST".

REF. NO	PART NO.	KANRI NO.	DESCRIPTION
1	8A-NF8-927-010	IB, EZ (9L) M 42 (RDS) <42>	
1	8A-NF8-928-010	IB, EZ (9L) M 40<40>	
2	8Z-NF8-702-010	RC UNIT, RC-ZAS01	
3	87-006-225-010	ANT, LOOP ANT NC2	
4	87-A90-118-010	ANT, WIRE FM (Z)	

# PROTECTION OF EYES FROM LASER BEAM DURING SERVICING

This set employs laser. Therefore, be sure to follow carefully the instructions below when servicing.

## WARNING!

WHEN SERVICING, DO NOT APPROACH THE LASER EXIT WITH THE EYE TOO CLOSELY. IN CASE IT IS NECESSARY TO CONFIRM LASER BEAM EMISSION. BE SURE TO OBSERVE FROM A DISTANCE OF MORE THAN 30cm FROM THE SURFACE OF THE OBJECTIVE LENS ON THE OPTICAL PICK-UP BLOCK.

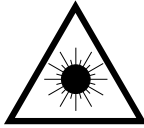

- Caution: Invisible laser radiation when open and interlocks defeated avoid exposure to beam.
- Advarsel: Usynlig laserstråling ved åbning, når sikkerhedsafbrydere er ude af funktion. Undgå udsættelse for stråling.

## VAROITUS!

Laiteen Käytön muuttaminen muulla kuin tässä käyttöohjeessa mainituilla tavalla saattaa altistaa käyttäjän turvallisuusluokan 1 ylittävälle näennäiselle lasersäteilylle.

## WARNING!

Om apparaten används på annat sätt än vad som specificeras i denna bruksanvisning, kan användaren utsättas för osynlig laserstrålning, som verskrider gränsen för laserklass 1.

## Precaution to replace Optical block

Body or clothes electrostatic potential could ruin laser diode in the optical block. Be sure ground body and workbench, and use care the clothes do not touch the diode.

- 1) After the connection, remove solder shown in the figure below.

## CAUTION

Use of controls or adjustments or performance of procedures other than those specified herein may result in hazardous radiation exposure.

## ATTENTION

L'utilisation de commandes, réglages ou procédures autres que ceux spécifiés peut entraîner une dangereuse exposition aux radiations.

## ADVARSEL!

Usynlig laserstråling ved åbning, når sikkerhedsafbrydere er ude af funktion. Undgå udsættelse for stråling.

This Compact Disc player is classified as a CLASS 1 LASER product.

The CLASS 1 LASER PRODUCT label is located on the rear exterior.

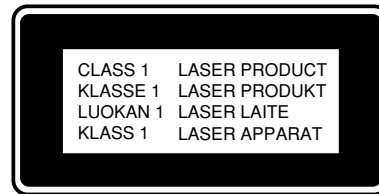

## ZA3/ZA4 (KSS-213F) MODEL

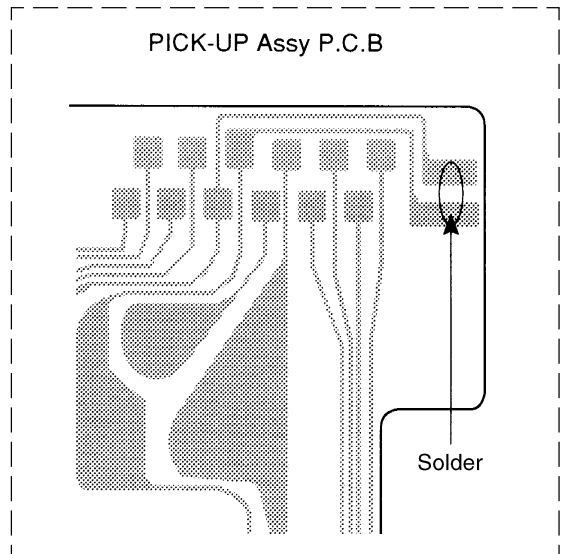

## ZA8/ZD8 MODEL

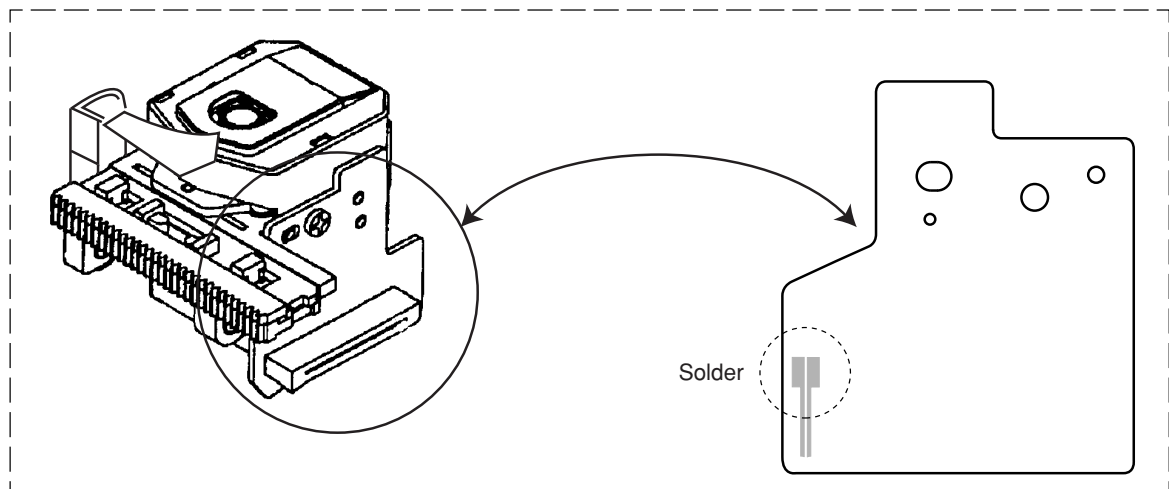

# NOTE ON BEFORE STARTING REPAIR

## 1. Forced discharge of electrolytic capacitor of power supply block

When repair is going to be attempted in the set that uses relay circuit in the power supply block, electric potential is kept charged across the electrolytic capacitors (C101, 102) even though AC power cord is removed. If repair is attempted in this condition, secondary defect can occur.

In order to prevent the secondary trouble, perform the following measures before starting repair work.

### Discharge procedure

- ① Remove the AC power cord.
- ② Connect a discharging resistor at an end of lead wire that has clips at both ends. Connect the other end of the lead wire to metal chassis.
- ③ Contact the other end of the discharging resistor to the positive (+) side (+VH) of C101. (For two seconds)
- ④ Contact the same end of the discharging resistor as step 3 to the negative (-) side (-VH) of C102 in the same way. (For two seconds)
- ⑤ Check that voltage across C101 and C102 has decreased to 1 V or less using a multimeter or an oscilloscope.

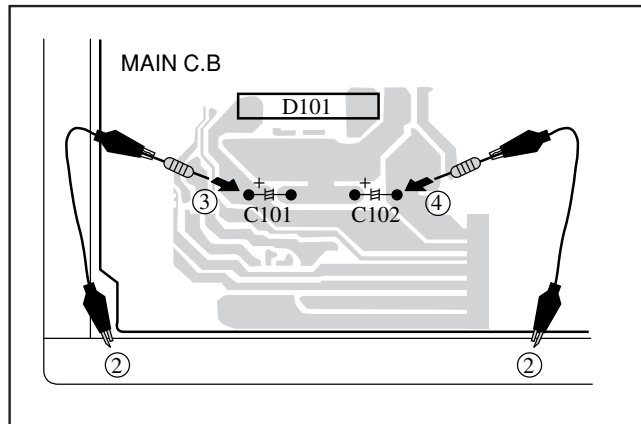

Select a discharging resistor referring to the following table.

Charging voltage (V) (C101, 102)	Discharging resistor ( $\Omega$ )	Rated power (W)	Parts number
25-48	100	3	87-A00-247-090
49-140	220	5	87-A00-232-090

**Note:** The reference numbers (C101, C102) of the electrolytic capacitors can change depending on the models. Be sure to check the reference numbers of the charging capacitors on schematic diagram before starting the discharging work.

## 2. Check items before exchanging the MICROCOMPUTER

Be sure to check the following items before exchanging the MICROCOMPUTER. Exchange the MICROCOMPUTER after confirming that the MICROCOMPUTER is surely defective.

### 2-1. Regarding the HOLD terminal of the MICROCOMPUTER

When the HOLD terminal (INPUT) of the MICROCOMPUTER is “H”, the MICROCOMPUTER is judged to be operating correctly. When this terminal is “L”, the main power cannot be turned on. Therefore, be sure to check the terminal voltage of the HOLD terminal before exchange.

When the MICROCOMPUTER is not defective, the HOLD terminal can also go “L” when the POWER AMPLIFIER has any abnormalities that triggers the abnormality detection circuit on the MAIN C. B. that sets the HOLD terminal to “L”.

#### • Good or no good judgement of the MICROCOMPUTER

- ① Turn on the AC main power.
- ② Confirm that the main power is turned on and the HOLD terminal of the MICROCOMPUTER keeps the “H” level or not.
- ③ When the HOLD terminal is “L” level, the abnormality detection circuit is judged to be working correctly and the MICROCOMPUTER is judged to be good.

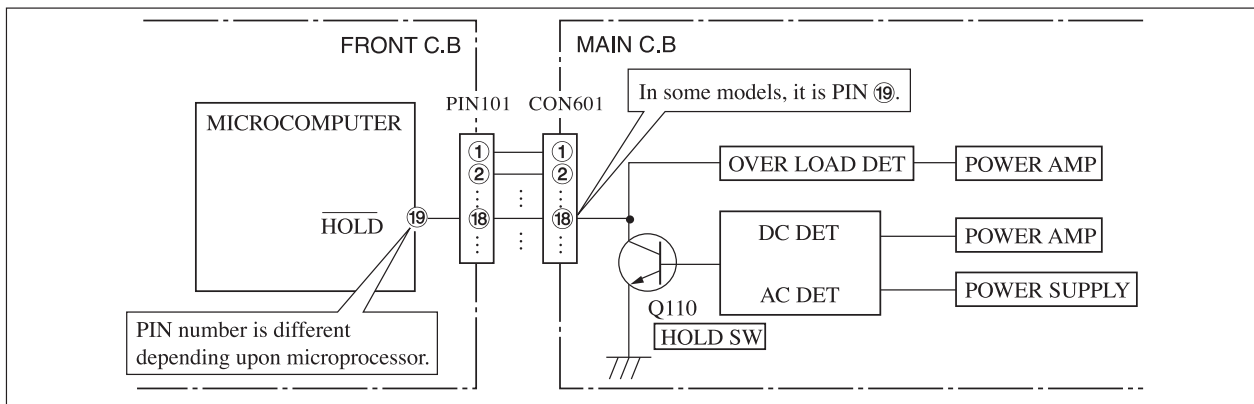

Fig-2-1

In such a case, check also if the POWER AMPLIFIER circuit or power supply circuit has any abnormalities or not.

## 2-2. Regarding reset

There are cases that the machine does not work correctly because the MICROCOMPUTER is not reset even though the AC power cord is re-inserted, or the software reset (pressing the STOP key + POWER key) is performed.

When the above described phenomenon occurs, it can lead to wrong judgement as if the MICROCOMPUTER is defective and to exchange the MICROCOMPUTER. In such a case, perform the forced-reset by the following procedure and check good or no good of the MICROCOMPUTER.

- ① Remove the AC power cord.

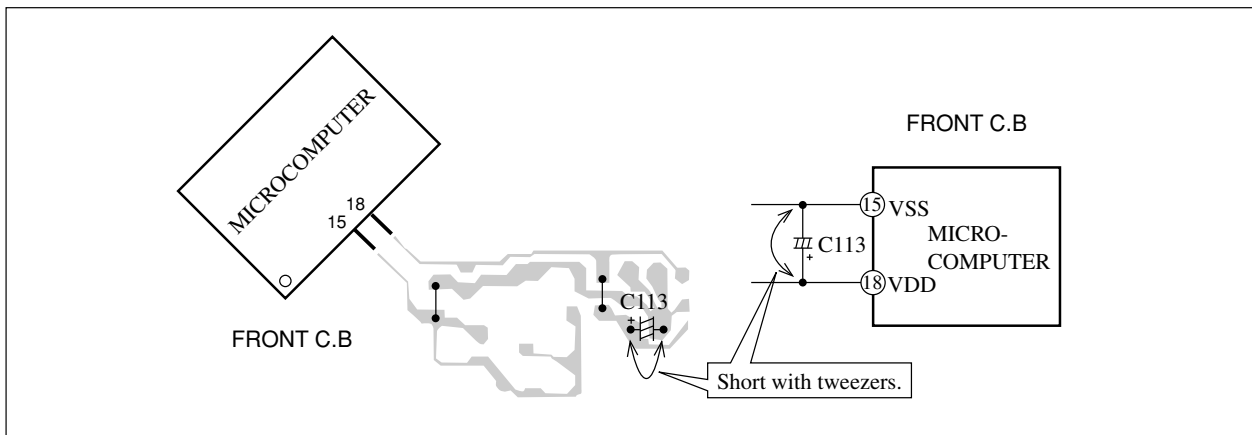

Fig-2-2

- ② Short both ends of the electrolytic capacitor C113 that is connected to VDD of the MICROCOMPUTER with tweezers.
- ③ Connect the AC power cord again. If the MICROCOMPUTER returns to the normal operation, the MICROCOMPUTER is good.

**Note:** The reference number or MICROCOMPUTER pin number of transistor (Q110) and electrolytic capacitor (C113) can change depending on the models. Be sure to check the reference numbers on schematic diagram before starting the discharging work.

## 2-3. Confirmation of soldering state of MICROCOMPUTER

Check the soldering state of the MICROCOMPUTER in addition to the above described procedures. Be sure to exchange the MICROCOMPUTER after surely confirming that the trouble is not caused by poor soldering but the MICROCOMPUTER itself.

# ELECTRICAL MAIN PARTS LIST

DESCRIPTIONで判断できない物は "REFERENCE NAME LIST" を参照してください。  
 If can't understand for Description please kindly refer to "REFERENCE NAME LIST".

REF. NO	PART NO.	KANRI NO.	DESCRIPTION	REF. NO	PART NO.	KANRI NO.	DESCRIPTION
<b>IC</b>							
	87-020-454-010	IC, DN6851		C0023	87-016-658-000		CAP, E 4700-35 M SMG
	87-A21-355-010	IC, STK490-140		C0024	87-016-658-000		CAP, E 4700-35 M SMG
	8A-NF8-620-010	C-IC, LC866548V-5R49<40>		C0025	87-010-408-080		CAP, E 47-50 M 11L SME
	8A-NF8-621-010	C-IC, LC866560W-5R50<42>		C0026	87-010-247-080		CAP, E 100-50 M SME
	87-A21-629-010	IC, SPS-442-1-N		C0030	87-010-430-080		CAP, E 100-63
	87-A21-419-040	C-IC, NJM14558MD-TE2		C0031	87-010-263-080		CAP, E 100-10 M 11L SME
	87-A21-577-040	C-IC, M61506FP		C0032	87-010-197-080		C-CAP, S 0.01-25 K B C2012
	87-070-289-040	C-IC, BU2092F		C0034	87-010-260-080		CAP, E 47-25 M 11L SME
	87-A21-401-040	C-IC, M61503FP		C0035	87-010-380-080		CAP, E 47-16 M 11L SME
	87-A21-560-010	IC, LA1844L-A		C0036	87-010-381-080		CAP, E 330-16 M SME
	87-A20-440-040	C-IC, BU1920FS<42>		C0038	87-010-197-080		C-CAP, S 0.01-25 K B C2012
	87-070-127-110	IC, LC72131D		C0060	87-010-403-080		CAP, E 3.3-50 M 11L SME
				C0061	87-010-260-080		CAP, E 47-25 M 11L SME
				C0101	87-010-183-080		C-CAP, S 2700P-50 K B GRM
				C0102	87-010-183-080		C-CAP, S 2700P-50 K B GRM
<b>TRANSISTOR</b>							
	87-026-609-080	TR, KTA1266GR		C0103	87-010-545-080		CAP, E 0.22-50 M 11L SME
	89-213-702-010	TR, 2SB1370E		C0104	87-010-545-080		CAP, E 0.22-50 M 11L SME
	87-026-610-080	TR, KTC3198GR		C0107	87-010-405-080		CAP, E 10-50 M 11L SME
	87-A30-076-080	C-TR, 2SC3052F		C0108	87-010-405-080		CAP, E 10-50 M 11L SME
	87-A30-075-080	C-TR, 2SA1235F		C0109	87-010-179-080		C-CAP, S 1200P-50 K B GRM
	87-026-245-080	TR, DTC114ES		C0110	87-010-179-080		C-CAP, S 1200P-50 K B GRM
	87-A30-198-080	TR, KTC3199GR		C0111	87-010-405-080		CAP, E 10-50 M 11L SME
	87-A30-107-070	C-TR, CMBT5401		C0112	87-010-405-080		CAP, E 10-50 M 11L SME
	87-A30-106-040	C-TR, CMBT5551		C0113	87-A12-180-080		CAP, E 10-63 M 105 KME
	87-A30-087-080	C-FET, 2SK2158		C0114	87-A12-180-080		CAP, E 10-63 M 105 KME
	87-A30-074-080	C-TR, RT1P 141C		C0119	87-010-197-080		C-CAP, S 0.01-25 K B C2012
	87-A30-318-080	TR, CSA952K		C0120	87-010-197-080		C-CAP, S 0.01-25 K B C2012
	87-A30-091-080	FET, 2SJ460		C0123	87-010-176-080		C-CAP, S 680P-50 J SL
	87-A30-329-080	TR, CD1585BC		C0124	87-010-176-080		C-CAP, S 680P-50 J SL
	87-A30-090-080	FET, 2SK2541		C0125	87-012-368-080		C-CAP, S 0.1-50 Z F
	87-A30-104-080	C-TR, RT1N 441C		C0126	87-012-368-080		C-CAP, S 0.1-50 Z F
	87-A30-468-080	C-TR, KRC102S-RTK		C0127	87-012-368-080		C-CAP, S 0.1-50 Z F
	87-A30-484-080	C-TR, KRA102S		C0128	87-012-368-080		C-CAP, S 0.1-50 Z F
	89-333-317-880	TR, 2SC3331 (T/U)		C0129	87-010-191-080		C-CAP, S 0.015-50 Z F GRM
	89-327-143-080	C-TR, 2SC27140		C0130	87-010-191-080		C-CAP, S 0.015-50 Z F GRM
	87-A30-489-080	C-TR, KRA107S		C0131	87-010-197-080		C-CAP, S 0.01-25 K B C2012
	87-A30-086-070	C-TR, CSD1306E		C0132	87-010-197-080		C-CAP, S 0.01-25 K B C2012
	89-503-602-080	C-FET, 2SK360E		C0133	87-010-186-080		C-CAP, S 4700P-50 K B C2012
	87-A30-234-080	TR, CSC4115BC		C0134	87-010-379-080		CAP, E 22-16 M 11L SME
				C0140	87-010-182-080		C-CAP, S 2200P-50 K B C2012
				C0141	87-010-196-080		C-CAP, S 0.1-25 Z F C2012
				C0237	87-010-322-080		C-CAP, S 100P-50 J CH GRM
				C0238	87-010-322-080		C-CAP, S 100P-50 J CH GRM
				C0301	87-010-178-080		C-CAP, S 1000P-50 K B C2012
				C0302	87-010-178-080		C-CAP, S 1000P-50 K B C2012
	87-A40-393-090	DIODE, 1N5402GW (F20)		C0303	87-010-179-080		C-CAP, S 1200P-50 K B GRM
	87-020-465-080	DIODE, 1SS133		C0304	87-010-179-080		C-CAP, S 1200P-50 K B GRM
	87-A40-547-090	DIODE, D5SBA20		C0307	87-010-263-080		CAP, E 100-10 M 11L SME
	87-A40-553-080	DIODE, 1N4003 LES		C0308	87-010-263-080		CAP, E 100-10 M 11L SME
	87-A40-776-080	ZENER, UZ27B5D		C0309	87-010-318-080		C-CAP, S 47P-50 J CH GRM
	87-A40-764-080	ZENER, UZ10B5C		C0310	87-010-318-080		C-CAP, S 47P-50 J CH GRM
	87-A40-270-080	C-DIODE, MC2838		C0313	87-010-188-080		C-CAP, S 6800P-50 K B C2012
	87-A40-313-080	C-DIODE, MC2840		C0314	87-010-188-080		C-CAP, S 6800P-50 K B C2012
	87-A40-269-080	C-DIODE, MC2836		C0315	87-010-263-080		CAP, E 100-10 M 11L SME
	87-A40-768-080	ZENER, UZ16B5A		C0317	87-010-546-080		CAP, E 0.33-50 M 11L SME
	87-A40-752-080	ZENER, UZ6.2B5C		C0318	87-010-546-080		CAP, E 0.33-50 M 11L SME
	87-A40-802-080	ZENER, UZ5.1B5C		C0326	87-010-198-080		C-CAP, S 0.022-25 K B C2012
	87-A40-739-080	ZENER, UZ2.7B5A		C0327	87-012-368-080		C-CAP, S 0.1-50 Z F
	87-017-149-080	ZENER, HZS6A2L		C0360	87-010-401-080		CAP, E 1-50 M 11L SME
				C0365	87-010-197-080		C-CAP, S 0.01-25 K B C2012
<b>MAIN C.B</b>							
C0003	87-012-368-080	C-CAP, S 0.1-50 Z F		C0399	87-012-140-080		C-CAP, S 470P-50 J CH
C0004	87-012-368-080	C-CAP, S 0.1-50 Z F		C0401	87-010-544-080		CAP, E 0.1-50 M 11L SME
C0005	87-012-368-080	C-CAP, S 0.1-50 Z F		C0402	87-010-544-080		CAP, E 0.1-50 M 11L SME
C0006	87-012-368-080	C-CAP, S 0.1-50 Z F		C0403	87-010-321-080		C-CAP, S 82P-50 J CH
C0015	87-012-368-080	C-CAP, S 0.1-50 Z F		C0404	87-010-321-080		C-CAP, S 82P-50 J CH
C0016	87-012-368-080	C-CAP, S 0.1-50 Z F		C0405	87-010-197-080		C-CAP, S 0.01-25 K B C2012
C0017	87-012-368-080	C-CAP, S 0.1-50 Z F		C0406	87-010-197-080		C-CAP, S 0.01-25 K B C2012
C0018	87-012-368-080	C-CAP, S 0.1-50 Z F		C0407	87-010-197-080		C-CAP, S 0.01-25 K B C2012
C0019	87-016-520-000	CAP, E 3300-65 M SMG		C0408	87-010-197-080		C-CAP, S 0.01-25 K B C2012
C0020	87-016-520-000	CAP, E 3300-65 M SMG		C0409	87-010-182-080		C-CAP, S 2200P-50 K B C2012

REF. NO	PART NO.	KANRI NO.	DESCRIPTION	REF. NO	PART NO.	KANRI NO.	DESCRIPTION
C0410	87-010-182-080		C-CAP,S 2200P-50 K B C2012	C0815	87-010-400-080		CAP,E 0.47-50 M 11L SME
C0411	87-010-405-080		CAP,E 10-50 M 11L SME	C0816	87-010-400-080		CAP,E 0.47-50 M 11L SME
C0412	87-010-405-080		CAP,E 10-50 M 11L SME	C0818	87-010-180-080		C-CAP,S 1500P-50 K B C2012
C0452	87-010-382-080		CAP,E 22-25 M 11L SME	C0821	87-010-405-080		CAP,E 10-50 M 11L SME
C0453	87-010-183-080		C-CAP,S 2700P-50 K B GRM	C0823	87-012-349-080		C-CAP,S 1000P-50 J CH GRM
C0454	87-010-183-080		C-CAP,S 2700P-50 K B GRM	C0824	87-010-404-080		CAP,E 4.7-50 M 11L SME
C0455	87-010-183-080		C-CAP,S 2700P-50 K B GRM	C0825	87-010-596-080		C-CAP,S 0.047-16 K R C2012
C0456	87-010-197-080		C-CAP,S 0.01-25 K B C2012	C0831	87-010-406-080		CAP,E 22-50 M 11L SME
C0458	87-010-178-080		C-CAP,S 1000P-50 K B C2012	C0842	87-010-197-080		C-CAP,S 0.01-25 K B C2012
C0459	87-010-175-080		C-CAP,S 560P-50 J SL	C0844	87-010-197-080		C-CAP,S 0.01-25 K B C2012
C0460	87-010-196-080		C-CAP,S 0.1-25 Z F C2012	C0850	87-010-260-080		CAP,E 47-25 M 11L SME
C0461	87-012-158-080		C-CAP,S 390P-50 J CH GRM	C0851	87-010-197-080		C-CAP,S 0.01-25 K B C2012
C0462	87-012-158-080		C-CAP,S 390P-50 J CH GRM	C0852	87-010-197-080		C-CAP,S 0.01-25 K B C2012
C0521	87-010-546-080		CAP,E 0.33-50 M 11L SME	C0853	87-010-197-080		C-CAP,S 0.01-25 K B C2012
C0522	87-010-546-080		CAP,E 0.33-50 M 11L SME	C0858	87-010-196-080		C-CAP,S 0.1-25 Z F C2012
C0605	87-010-184-080		C-CAP,S 3300P-50 K B C2012	C0859	87-010-196-080		C-CAP,S 0.1-25 Z F C2012
C0606	87-010-184-080		C-CAP,S 3300P-50 K B C2012	C0860	87-010-197-080		C-CAP,S 0.01-25 K B C2012
C0609	87-010-213-080		C-CAP,S 0.015-25 K B GRM	C0869	87-010-197-080		C-CAP,S 0.01-25 K B C2012<42>
C0610	87-010-213-080		C-CAP,S 0.015-25 K B GRM	C0870	87-018-131-080		CAP,TC U 1000P-50 K B UP050<42>
C0611	87-010-545-080		CAP,E 0.22-50 M 11L SME	C0871	87-012-156-080		C-CAP,S 220P-50 J CH GRM<42>
C0612	87-010-545-080		CAP,E 0.22-50 M 11L SME	C0872	87-012-156-080		C-CAP,S 220P-50 J CH GRM<42>
C0613	87-010-545-080		CAP,E 0.22-50 M 11L SME	C0873	87-012-140-080		C-CAP,S 470P-50 J CH<42>
C0614	87-010-545-080		CAP,E 0.22-50 M 11L SME	C0874	87-010-405-080		CAP,E 10-50 M 11L SME<42>
C0615	87-010-154-080		C-CAP,S 10P-50 D CH GRM	C0875	87-010-196-080		C-CAP,S 0.1-25 Z F C2012<42>
C0616	87-010-385-080		CAP,E 220-25 M SME	C0876	87-010-405-080		CAP,E 10-50 M 11L SME<42>
C0617	87-010-385-080		CAP,E 220-25 M SME	C0877	87-010-197-080		C-CAP,S 0.01-25 K B C2012<42>
C0618	87-010-405-080		CAP,E 10-50 M 11L SME	C0878	87-010-316-080		C-CAP,S 33P-50 J CH GRM<42>
C0620	87-010-263-080		CAP,E 100-10 M 11L SME	C0879	87-010-314-080		C-CAP,S 22P-50 J CH GRM<42>
C0630	87-016-669-080		C-CAP,S 0.1-25 K B	C0940	87-010-197-080		C-CAP,S 0.01-25 K B C2012
C0631	87-010-185-080		C-CAP,S 3900P-50 K B	C0942	87-010-149-080		C-CAP,S 5P-50 C CH GRM
C0632	87-010-185-080		C-CAP,S 3900P-50 K B	C0947	87-010-197-080		C-CAP,S 0.01-25 K B C2012
C0633	87-016-369-080		C-CAP,S 0.033-25 K B GRM	C0948	87-012-140-080		C-CAP,S 470P-50 J CH
C0634	87-016-369-080		C-CAP,S 0.033-25 K B GRM	C0952	87-010-197-080		C-CAP,S 0.01-25 K B C2012
C0661	87-012-157-080		C-CAP,S 330P-50 J CH GRM	C0957	87-010-311-080		C-CAP,S 12P-50 J CH GRM
C0662	87-012-157-080		C-CAP,S 330P-50 J CH GRM	C0958	87-010-197-080		C-CAP,S 0.01-25 K B C2012
C0669	87-010-180-080		C-CAP,S 1500P-50 K B C2012	C0959	87-010-196-080		C-CAP,S 0.1-25 Z F C2012
C0670	87-010-180-080		C-CAP,S 1500P-50 K B C2012	C0960	87-010-196-080		C-CAP,S 0.1-25 Z F C2012
C0677	87-010-197-080		C-CAP,S 0.01-25 K B C2012	C0962	87-010-401-080		CAP,E 1-50 M 11L SME
C0771	87-010-263-080		CAP,E 100-10 M 11L SME	C0963	87-015-785-080		C-CAP, 0.1-25 Z F C3216
C0772	87-010-197-080		C-CAP,S 0.01-25 K B C2012	C0971	87-010-381-080		CAP,E 330-16 M SME
C0779	87-010-186-080		C-CAP,S 4700P-50 K B C2012	C0972	87-010-404-080		CAP,E 4.7-50 M 11L SME
C0780	87-010-186-080		C-CAP,S 4700P-50 K B C2012	C0973	87-010-197-080		C-CAP,S 0.01-25 K B C2012
C0782	87-010-197-080		C-CAP,S 0.01-25 K B C2012	C0974	87-010-197-080		C-CAP,S 0.01-25 K B C2012
C0783	87-010-197-080		C-CAP,S 0.01-25 K B C2012	C0979	87-010-322-080		C-CAP,S 100P-50 J CH GRM
C0784	87-010-197-080		C-CAP,S 0.01-25 K B C2012	C0981	87-010-260-080		CAP,E 47-25 M 11L SME
C0785	87-010-197-080		C-CAP,S 0.01-25 K B C2012	C0982	87-010-196-080		C-CAP,S 0.1-25 Z F C2012
C0786	87-010-197-080		C-CAP,S 0.01-25 K B C2012	C0983	87-010-197-080		C-CAP,S 0.01-25 K B C2012
C0788	87-010-149-080		C-CAP,S 5P-50 C CH GRM	C0984	87-010-197-080		C-CAP,S 0.01-25 K B C2012
C0789	87-A10-801-080		C-CAP,S 0.022-16 J B CM	C0985	87-010-322-080		C-CAP,S 100P-50 J CH GRM
C0790	87-A10-801-080		C-CAP,S 0.022-16 J B CM	C0987	87-010-197-080		C-CAP,S 0.01-25 K B C2012
C0791	87-010-196-080		C-CAP,S 0.1-25 Z F C2012	C0989	87-010-197-080		C-CAP,S 0.01-25 K B C2012
C0792	87-010-197-080		C-CAP,S 0.01-25 K B C2012	C0991	87-010-312-080		C-CAP,S 15P-50 J CH GRM
C0793	87-010-404-080		CAP,E 4.7-50 M 11L SME	C0992	87-010-312-080		C-CAP,S 15P-50 J CH GRM
C0794	87-012-140-080		C-CAP,S 470P-50 J CH<40>	C0993	87-010-178-080		C-CAP,S 1000P-50 K B C2012
C0794	87-012-155-080		C-CAP,S 180P-50 J CH GRM<42>	C0995	87-010-178-080		C-CAP,S 1000P-50 K B C2012
C0795	87-010-197-080		C-CAP,S 0.01-25 K B C2012	C0997	87-010-196-080		C-CAP,S 0.1-25 Z F C2012
C0796	87-010-197-080		C-CAP,S 0.01-25 K B C2012	C0998	87-010-260-080		CAP,E 47-25 M 11L SME
C0797	87-010-405-080		CAP,E 10-50 M 11L SME	C0999	87-A11-132-080		CAP,TC U 0.01-50 K B
C0798	87-010-197-080		C-CAP,S 0.01-25 K B C2012	CF0831	87-008-423-010		FLTR,CF SFE10.7MS3G-A
C0799	87-010-407-080		CAP,E 33-50 M 11L SME	CF0832	82-785-747-010		CF,MS2 GHY,R
C0800	87-012-369-080		C-CAP,S 0.047-50 Z F	CN0301	87-A60-620-010		CONN,3P V 2MM JMT
C0801	87-010-403-080		CAP,E 3.3-50 M 11L SME	CN0351	87-A60-625-010		CONN,8P V 2MM JMT
C0802	87-010-194-080		C-CAP,S 0.047-25 Z F	CN0601	87-099-719-010		CONN,30P H BLK TYK-B(X)
C0803	87-010-198-080		C-CAP,S 0.022-25 K B C2012	CN0602	87-A60-131-010		CONN,6P V FE
C0804	87-010-263-080		CAP,E 100-10 M 11L SME	CNA0001	8A-NF8-654-010		CONN ASSY,11P TID-A(480)
C0807	87-010-400-080		CAP,E 0.47-50 M 11L SME	FB0602	87-008-372-080		FLTR,EMI BL01 RN1
C0808	87-010-401-080		CAP,E 1-50 M 11L SME	FFC602	88-906-251-110		FF-CABLE,6P 1.25
C0809	87-010-401-080		CAP,E 1-50 M 11L SME	FFE0831	A8-6ZA-191-130		6ZA-1 FEENM
C0810	87-010-196-080		C-CAP,S 0.1-25 Z F C2012	J0202	87-A60-488-010		JACK,DIA6.3 BLK ST W/SW KM16AT
C0814	87-010-197-080		C-CAP,S 0.01-25 K B C2012	J0203	87-A60-238-010		TERMINAL,SP 4P (MSC)

REF. NO	PART NO.	KANRI NO.	DESCRIPTION	REF. NO	PART NO.	KANRI NO.	DESCRIPTION
J0204	87-A60-881-010		JACK,PIN 2P MSP 242V05 PBSN	C0339	87-012-156-080		C-CAP,S 220P-50 J CH GRM
J0602	87-A60-881-010		JACK,PIN 2P MSP 242V05 PBSN	C0340	87-010-197-080		C-CAP,S 0.01-25 K B C2012
J0832	87-A60-403-010		TERMINAL,ANT PAL 2P HSP-312V05	C0341	87-010-194-080		C-CAP,S 0.047-25 Z F
JW0105	87-A00-764-010		RES,M/F 0.22-3W J	C0351	87-010-382-040		CAP,E 22-25 M 11L SME
JW0106	87-A00-764-010		RES,M/F 0.22-3W J	C0401	87-010-197-080		C-CAP,S 0.01-25 K B C2012
L0101	87-A50-610-010		COIL,1UH K(MDEC)	C0451	87-010-196-080		C-CAP,S 0.1-25 Z F C2012
L0102	87-A50-610-010		COIL,1UH K(MDEC)	C0452	87-010-196-080		C-CAP,S 0.1-25 Z F C2012
L0451	87-007-342-010		COIL,OSC 85KHZ BIAS	C0453	87-010-196-080		C-CAP,S 0.1-25 Z F C2012
L0801	87-A50-608-010		COIL,FM DET-N(TOK)	C0454	87-010-196-080		C-CAP,S 0.1-25 Z F C2012
L0802	87-A91-551-010		FLTR,PCFJZH-450 L(TOK)	C0455	87-010-196-080		C-CAP,S 0.1-25 Z F C2012
L0811	87-005-847-080		COIL,2.2UH K CECS	C0458	87-010-320-080		C-CAP,S 68P-50 J CH GRM
L0832	87-005-847-080		COIL,2.2UH K CECS	C0459	87-010-320-080		C-CAP,S 68P-50 J CH GRM
L0861	87-005-847-080		COIL,2.2UH K CECS<42>	C0602	87-010-322-080		C-CAP,S 100P-50 J CH GRM
L0941	87-A50-020-010		COIL,ANT LW (COI) 252KHZ	C0603	87-010-322-080		C-CAP,S 100P-50 J CH GRM
L0942	87-A50-019-010		COIL,OSC LW (COI) 856KHZ	C0604	87-010-322-080		C-CAP,S 100P-50 J CH GRM
L0951	8A-NF8-668-010		COIL,AM PACK 2(TOK)	C0650	87-010-196-080		C-CAP,S 0.1-25 Z F C2012
R0129	87-A00-764-010		RES,M/F 0.22-3W J	C0699	87-010-196-080		C-CAP,S 0.1-25 Z F C2012
R0130	87-A00-764-010		RES,M/F 0.22-3W J	CN0101	87-099-720-010		CONN,30P BLK TYK-B(P)
R0143	87-A00-439-050		RES,180-1/2W J RP	CN0102	87-099-015-010		CONN,13P V BLK 6216
R0144	87-A00-439-050		RES,180-1/2W J RP	CN0302	87-A60-136-010		CONN,11P V FE
R0145	87-A00-439-050		RES,180-1/2W J RP	FB0301	87-008-372-080		FLTR,EMI BL01 RN1
R0146	87-A00-439-050		RES,180-1/2W J RP	FFC102	88-913-301-110		FF-CABLE,13P-1.25
R0790	87-010-197-080		C-CAP,S 0.01-25 K B C2012	FFC105	88-911-101-110		FF-CABLE,11P 1.25
R0991	87-010-322-080		C-CAP,S 100P-50 J CH GRM	FL0401	8A-NF8-601-010		FL,HNA-11MM30(ANF-8)
R0993	87-010-322-080		C-CAP,S 100P-50 J CH GRM	L0331	87-A50-408-010		COIL,OSC 5.76MHZ
R0995	87-010-322-080		C-CAP,S 100P-50 J CH GRM	LED0311	87-A40-589-040		LED,SLR-56VCT31 RED
SFR0451	87-A90-432-080		SFR,30K H NVZ6TLTA	LED0601	87-A40-803-010		LED,SELU1E10CXM-S LF38 BLUE
SFR0452	87-A90-432-080		SFR,30K H NVZ6TLTA	LED0602	87-A40-619-080		LED,SLR-56PT-TE7-W GRN
TC0942	87-011-253-080		TRMMER,CER 30P 4.0X4.5 ECLRA	LED0603	87-A40-619-080		LED,SLR-56PT-TE7-W GRN
WH0001	87-A91-179-010		HLDR,WIRE 2.5-11P	LED0604	87-A40-619-080		LED,SLR-56PT-TE7-W GRN
X0861	87-A70-091-010		VIB,XTAL 4.332MHZ CSA-309<42>	LED0606	87-A40-619-080		LED,SLR-56PT-TE7-W GRN
X0991	87-A70-061-010		VIB,XTAL 4.500MHZ CSA-309	LED0607	87-A40-619-080		LED,SLR-56PT-TE7-W GRN
				LED0608	87-A40-619-080		LED,SLR-56PT-TE7-W GRN
				S0401	87-A91-024-180		SW,TACT KSHG611BT
				S0402	87-A91-024-180		SW,TACT KSHG611BT
FRONT C.B							
C0201	87-010-322-080		C-CAP,S 100P-50 J CH GRM	S0403	87-A91-024-180		SW,TACT KSHG611BT
C0202	87-010-322-080		C-CAP,S 100P-50 J CH GRM	S0404	87-A91-024-180		SW,TACT KSHG611BT
C0203	87-010-322-080		C-CAP,S 100P-50 J CH GRM	S0405	87-A91-024-180		SW,TACT KSHG611BT
C0204	87-010-322-080		C-CAP,S 100P-50 J CH GRM	S0406	87-A91-024-180		SW,TACT KSHG611BT
C0205	87-010-322-080		C-CAP,S 100P-50 J CH GRM	S0407	87-A91-024-180		SW,TACT KSHG611BT
C0206	87-010-322-080		C-CAP,S 100P-50 J CH GRM	S0408	87-A91-024-180		SW,TACT KSHG611BT
C0207	87-010-322-080		C-CAP,S 100P-50 J CH GRM	S0409	87-A91-024-180		SW,TACT KSHG611BT
C0208	87-010-322-080		C-CAP,S 100P-50 J CH GRM	S0410	87-A91-024-180		SW,TACT KSHG611BT
C0209	87-010-322-080		C-CAP,S 100P-50 J CH GRM	S0411	87-A91-024-180		SW,TACT KSHG611BT
C0210	87-010-322-080		C-CAP,S 100P-50 J CH GRM	S0412	87-A91-024-180		SW,TACT KSHG611BT<42>
C0211	87-010-322-080		C-CAP,S 100P-50 J CH GRM	S0413	87-A91-024-180		SW,TACT KSHG611BT
C0251	87-010-405-040		CAP,E 10-50 M 11L SME	S0414	87-A91-024-180		SW,TACT KSHG611BT
C0253	87-010-196-080		C-CAP,S 0.1-25 Z F C2012	S0415	87-A91-024-180		SW,TACT KSHG611BT
C0254	87-012-369-080		C-CAP,S 0.047-50 Z F	S0416	87-A91-024-180		SW,TACT KSHG611BT
C0255	87-010-560-040		CAP,E 10-50 M 5L MA	S0417	87-A91-024-180		SW,TACT KSHG611BT
C0256	87-010-405-040		CAP,E 10-50 M 11L SME	S0418	87-A91-024-180		SW,TACT KSHG611BT
C0259	87-010-405-040		CAP,E 10-50 M 11L SME	S0419	87-A91-024-180		SW,TACT KSHG611BT
C0264	87-A11-148-080		CAP,TC U 0.1-50 Z F	S0420	87-A91-024-180		SW,TACT KSHG611BT<42>
C0273	87-010-178-080		C-CAP,S 1000P-50 K B C2012	S0421	87-A91-024-180		SW,TACT KSHG611BT<42>
C0274	87-010-178-080		C-CAP,S 1000P-50 K B C2012	S0425	87-A91-024-180		SW,TACT KSHG611BT
C0301	87-010-182-080		C-CAP,S 2200P-50 K B C2012	S0426	87-A91-024-180		SW,TACT KSHG611BT
C0302	87-010-196-080		C-CAP,S 0.1-25 Z F C2012	S0430	87-A91-024-180		SW,TACT KSHG611BT
C0303	87-010-196-080		C-CAP,S 0.1-25 Z F C2012	S0431	87-A91-024-180		SW,TACT KSHG611BT
C0312	87-010-498-040		CAP,E 10-16 M 5L SRE	S0432	87-A91-024-180		SW,TACT KSHG611BT
C0314	87-010-196-080		C-CAP,S 0.1-25 Z F C2012	S0433	87-A91-024-180		SW,TACT KSHG611BT
C0315	87-010-196-080		C-CAP,S 0.1-25 Z F C2012	S0434	87-A91-024-180		SW,TACT KSHG611BT
C0316	87-010-196-080		C-CAP,S 0.1-25 Z F C2012	S0435	87-A91-024-180		SW,TACT KSHG611BT
C0321	87-012-393-080		C-CAP,S 0.22-16 K W5R CM/CB	SW0252	87-A91-555-010		SW,RTRY EC12E24504
C0322	87-010-400-040		CAP,E 0.47-50 M 11L SME	SW0253	87-A91-542-010		SW,RTRY EC12E12504
C0325	87-A10-189-040		CAP,E 220-10 M 5L				
C0326	87-A10-189-040		CAP,E 220-10 M 5L	DECK C.B			
C0332	87-010-178-080		C-CAP,S 1000P-50 K B C2012	CON105	87-099-753-010		CONN,11P 9604 S F
C0334	87-010-312-080		C-CAP,S 15P-50 J CH GRM	SFR1	87-024-581-010		SFR,3.3K DIA 6H
C0335	87-012-140-080		C-CAP,S 470P-50 J CH	SOL1	82-ZM1-618-410		SOL ASSY,27
C0336	87-012-155-080		C-CAP,S 180P-50 J CH GRM				



REF. NO	PART NO.	KANRI NO.	DESCRIPTION
SOL2	82-ZM1-618-410		SOL ASSY, 27
SW1	87-A90-248-010		SW, MICRO ESE11SH2CXQ
SW2	87-A90-248-010		SW, MICRO ESE11SH2CXQ
SW3	87-A90-248-010		SW, MICRO ESE11SH2CXQ
SW4	87-036-110-010		SW, MICRO SPPB62
SW5	87-036-110-010		SW, MICRO SPPB62
W1	82-ZM3-601-010		RBN, CORD, 4P-75

HEAD-1 C.B

	85-ZM3-602-010		PWB, FLEX A
CON301	87-NF6-615-010		CONN ASSY, 3P PB

PT C.B

C0001	87-010-387-080		CAP, E 470-25 M SME
C0002	87-A11-148-080		CAP, TC U 0.1-50 Z F
C0031	87-010-403-040		CAP, E 3.3-50 M 11L SME
CN0001	87-A61-122-010		CONN, 11P V TID-A
△PT0001	8A-NFJ-608-010		PT, ANF-8 EZ (2)
△PT0002	8A-NF8-662-010		PT, SUB ANF-8 (E)
△RY0002	87-A91-418-010		RELAY, AC12V G5PA-1-M
△T0001	87-A60-317-010		TERMINAL, 1P MSC
△T0002	87-A60-317-010		TERMINAL, 1P MSC

○チップ抵抗部品コード/CHIP RESISTOR PART CODE

チップ抵抗部品コードの成り立ち

Chip Resistor Part Coding



A  
抵抗部品コード  
Resistor Code

桁表示  
Figure  
抵抗値  
Value of resistor

チップ抵抗  
Chip resistor

容量 Wattage	種類 Type	許容誤差 Tolerance	記号 Symbol	寸法/Dimensions (mm)			抵抗コード : A Resistor Code : A	
				外形/Form	L	W		t
1/16W	1005	± 5%	CJ		1.0	0.5	0.35	104
1/16W	1608	± 5%	CJ		1.6	0.8	0.45	108
1/10W	2125	± 5%	CJ		2	1.25	0.45	118
1/8W	3216	± 5%	CJ		3.2	1.6	0.55	128

# TRANSISTOR ILLUSTRATION



E C B

2SC3331  
CD1585  
CSA952  
CSC4115  
KTA1266  
KTC3198

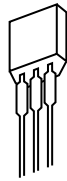

E C B

DTC114ES  
KTC3199



B C E

2SB1370

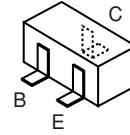

B C E

2SA1235  
2SC2714  
2SC3052  
CMBT5401  
CMBT5551  
CSD1306  
KRA102S  
KRA107S  
KRC102S  
KTC102S  
RT1N441C  
RT1P141C

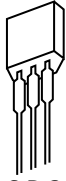

S D G

2SJ460  
2SK2541

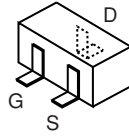

G S D

2SK2158

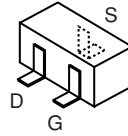

D S G

2SK360

GRID ASSIGNMENT

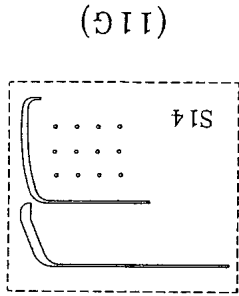

(11G)

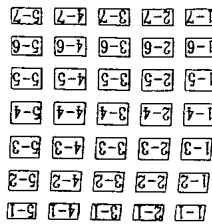

(3G-10G)

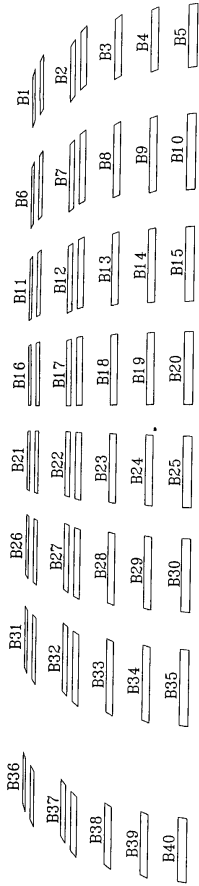

(1G)

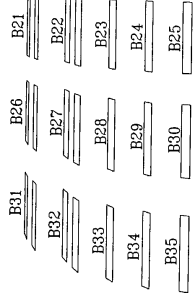

(2G)

ANODE CONNECTION

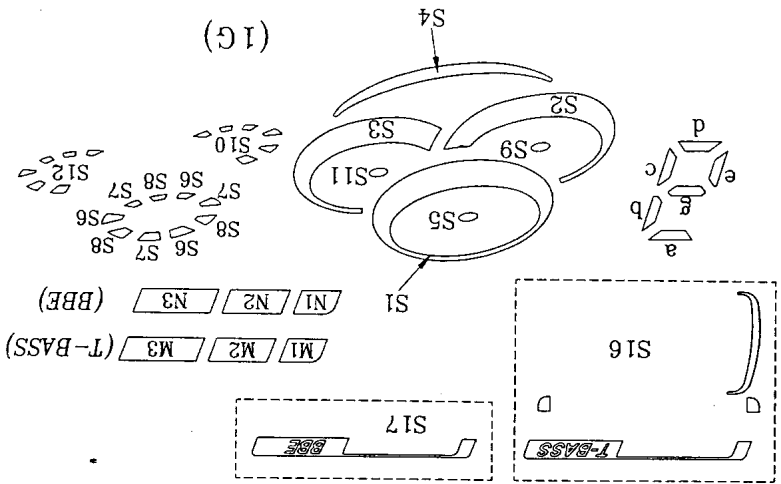
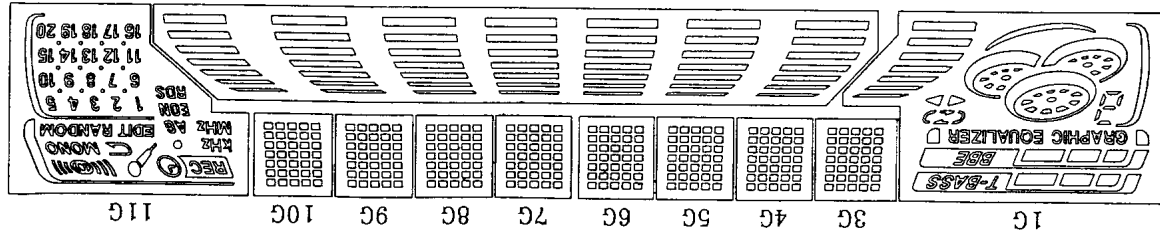

(1G)

	1G	2G	3G-10G	11G
P1	S17	B35	1-1	U
P2	N1	B30	2-1	MONO
P3	N2	B25	3-1	RANDOM
P4	N3	B20	4-1	EDIT
P5	GRAPHIC EQUALIZER	B15	5-1	REC
P6	△	B10	1-2	kHz
P7	○	B5	2-2	MHz
P8	□	B34	3-2	AG
P9	△	B29	4-2	EON
P10	○	B24	5-2	RDS
P11	S4	B19	1-3	S14
P12	S2	B14	2-3	20
P13	S10	B9	3-3	19
P14	S9	B4	4-3	18
P15	S3	B33	5-3	17
P16	S12	B28	1-4	
P17	S11	B23	2-4	
P18	S1	B18	3-4	

	1G	2G	3G-10G	11G
P19	S6	B13	4-4	16
P20	S7	B8	5-4	15
P21	S8	B3	1-5	14
P22	S5	B32	2-5	13
P23	S16	B27	3-5	12
P24	M1	B22	4-5	11
P25	M2	B17	5-5	10
P26	M3	B12	1-6	9
P27	e	B7	2-6	8
P28	a,g,d	B2	3-6	7
P29	b	B31	4-6	6
P30	c	B26	5-6	5
P31	B40	B21	1-7	4
P32	B39	B16	2-7	3
P33	B38	B11	3-7	2
P34	B37	B6	4-7	1
P35	B36	B1	5-7	



SCHEMATIC DIAGRAM-1 (FUNCTION/AMP SECTION)

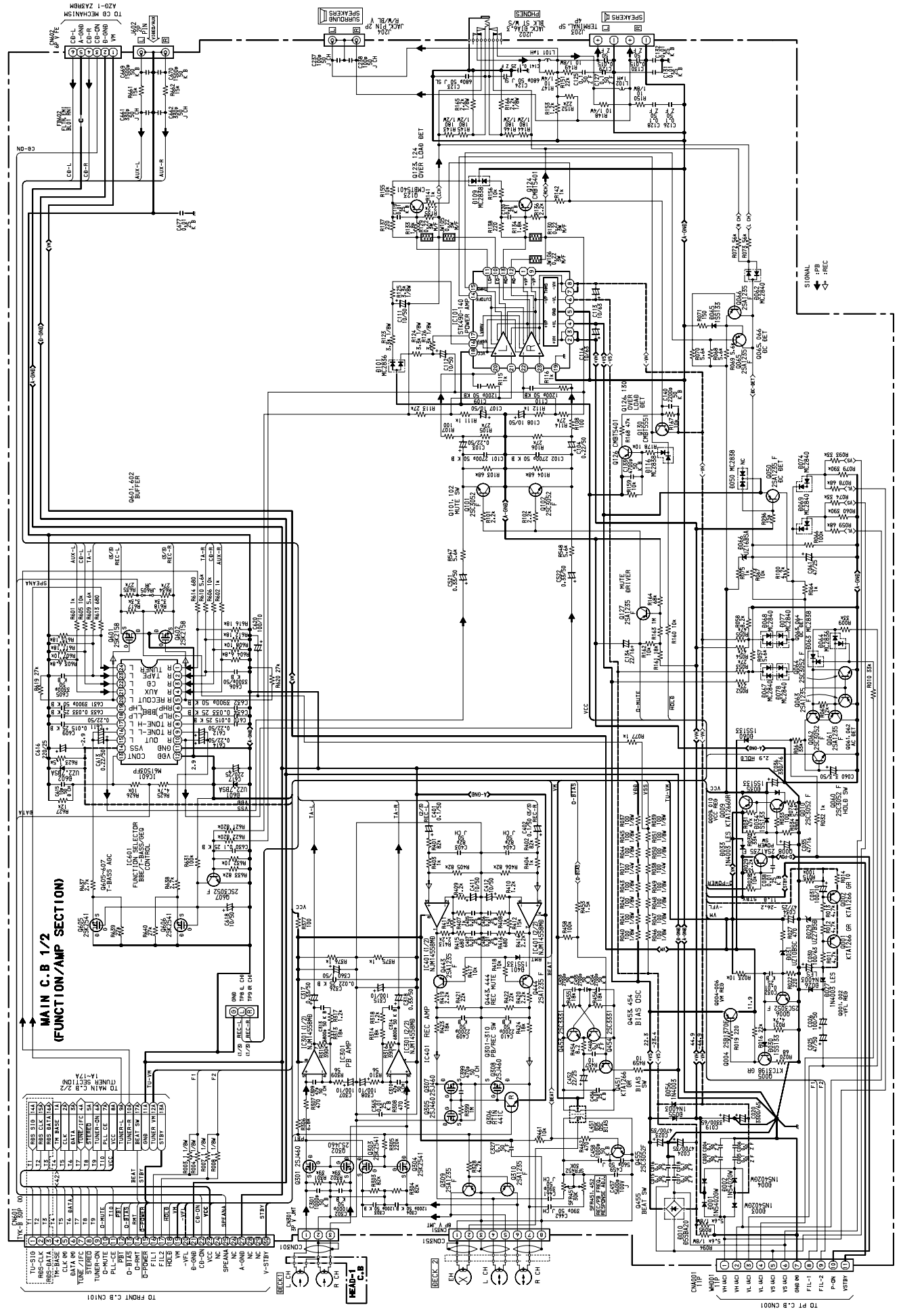

SCHEMATIC DIAGRAM-2 (TUNER SECTION)

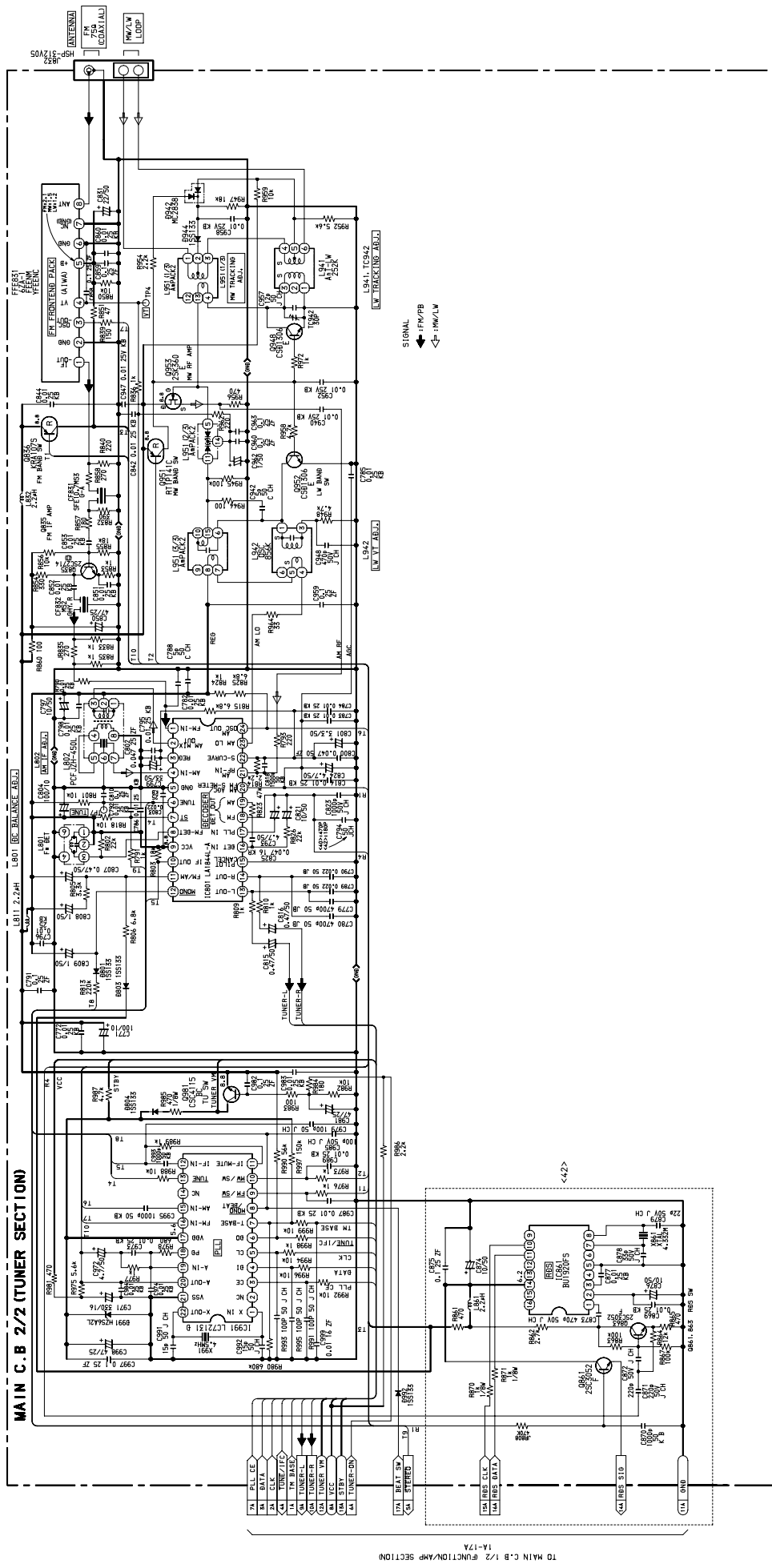









IC BLOCK DIAGRAM  
IC, LA1844

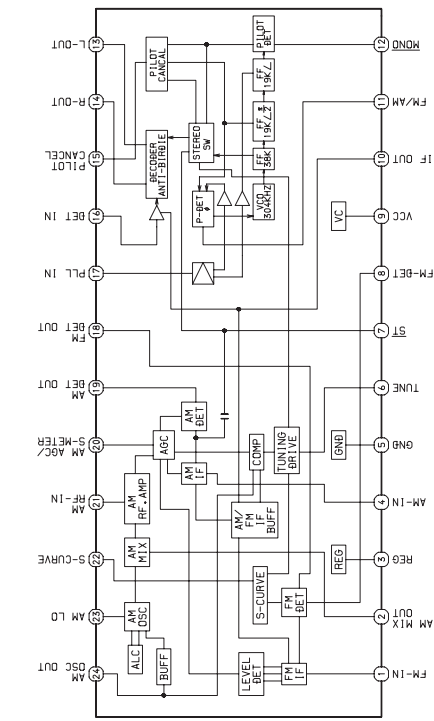

IC, LC72131D

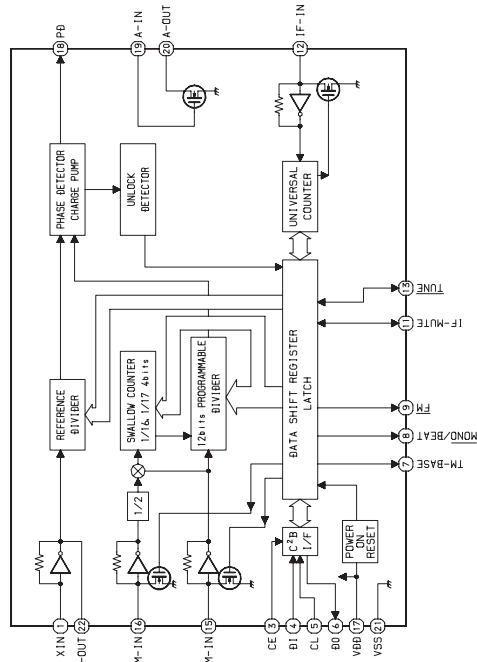

IC, M61506FP

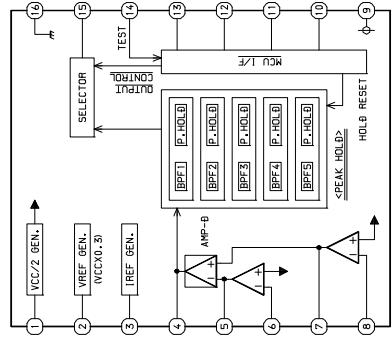

IC, M61503FP

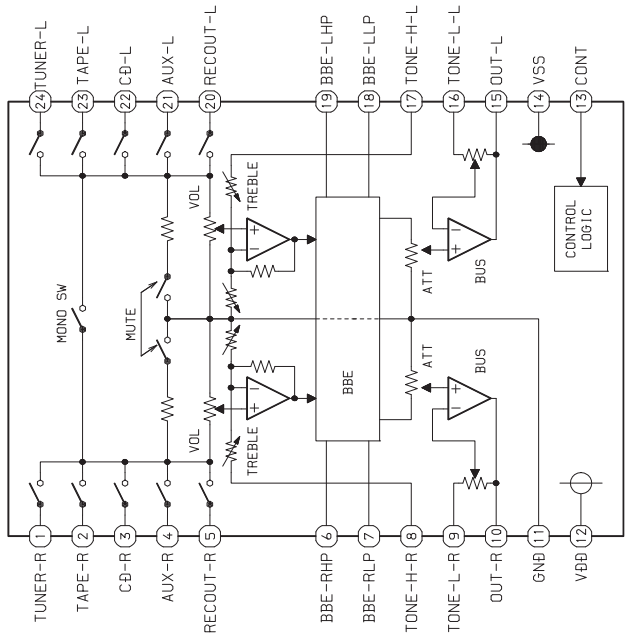

IC, BU2092F

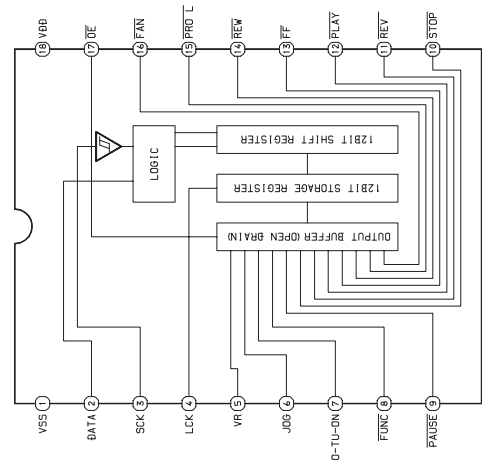

## IC DESCRIPTION

IC, LC866548V-5R49 <40>, LC866560V-5R50 <42>

Pin No.	Pin Name	I/O	Description
1	I-STEREO/I-DRF	I	Stereo detected input/CD DRF input
2	I-IFC/I-SUBQ	I	Tune IF count serial data input/CD SUBQ input
3	O-2PB	O	Deck 2 playback switch output
4	O-POWER	O	System power supply ON/OFF output
5	O-CD-ON	O	CD power ON/OFF output
6	O-PLL_DATA	O	LED driver, Tuner IC, Function IC data output
7	O-RMT	O	Deck 2 REC MUTE output
8	O-BIAS	O	Deck 2 bias ON/OFF output
9	O-MUTE	O	System mute ON/OFF output
10	O-STB	O	Latch strobe output for LED driver IC
11	O-CLK_SFT	O	Micon clock shift output
12	RESET	I	System reset
13	NC	-	Not connected
14	I-DISH	I	CD turntable photo sensor A/D converter input
15	VSS1	-	GND
16	CF1	-	5.76 MHz oscillator circuit
17	CF2	-	5.76 MHz oscillator circuit
18	VDD1	-	Power supply input
19	I-HOLD	I	Power failure detected input
20	I-KEY1	I	KEY input (A/D)
21	I-KEY2	I	KEY input (A/D)
22	I-KEY3	I	KEY input (A/D)
23	I-TU_SIG	I	Tuner signal input
24	I-CDSW	I	CD mechanical switch A/D converter input
25	I-SPEANA	I	A/D input for spectrum analyzer display
26	I-RE_VOL	I	Rotary encoder input (VOL)
27	I-WRQ/I-RDS_CLK	I	CD WRQ input/Tuner RDS clock input
28	I-TM_BASE	I	Reference clock input for timer watch
29	I-RMC	I	System remotecontrol signal input
30 ~ 40	G11 ~ G1	O	FL GRID output G11 ~ G1
41	NC	-	Not connected
42 ~ 45	P35 ~ P32	O	FL SEGMENT output P35 ~ P32
46	VDD3	-	Power supply input
47 ~ 48	P31 ~ P30	O	FL SEGMENT output P31 ~ P30
49	P29/O-SPEANA-C	O	FL SEGMENT output P29/Spectrum analyzer band switching output
50	P28/O-SPEANA-B	O	FL SEGMENT output P28/Spectrum analyzer band switching output
51	VFL	-	Power supply input for FL display
52	P27/O-SPEANA-A	O	FL SEGMENT output P27/Spectrum analyzer band switch output
53	P26	O	FL SEGMENT output P26
54	P25/I-NO_CASINO	I/O	FL SEGMENT output P25/NO CASINO DEMO input to diode
55	P24/I-KARAOKE	I/O	FL SEGMENT output P24/KARAOKE input to diode
56	P23/NO_DEMO	I/O	FL SEGMENT output P23/NO DEMO input to diode

Pin No.	Pin Name	I/O	Description
57	P22/PRO LOGIC	I/O	FL SEGMENT output P22/PROLOGIC input to diode (not used)
58	P21/RDS	I/O	FL SEGMENT output P21/RDS input to diode
59	P20/FM1	I/O	FL SEGMENT output P20/FM1 input to diode
60	P19/SW	I/O	FL SEGMENT output P19/SW input to diode
61	P18/LW	I/O	FL SEGMENT output P18/LW input to diode
62	P17/AMST	I/O	FL SEGMENT output P17/AMST input to diode
63	P16/AM10K	I/O	FL SEGMENT output P16/AM10K input to diode
64	P15/I- $\overline{\text{CST2}}$	I/O	FL SEGMENT output P15/DECK2 cassette detect switch data input
65	P14/I- $\overline{\text{REB}}$	I/O	FL SEGMENT output P14/DECK2 side-B record OK switch data input
66	P13/I- $\overline{\text{CAM2}}$	I/O	FL SEGMENT output P13/DECK2 CAM switch signal input
67	P12/I- $\overline{\text{AUTO1}}$	I/O	FL SEGMENT output P12/DECK1 AUTO STOP signal input
68	P11/I- $\overline{\text{AUTO2}}$	I/O	FL SEGMENT output P11/DECK2 AUTO STOP signal input
69	P10/I- $\overline{\text{CAM1}}$	I/O	FL SEGMENT output P10/DECK1 CAM switch data input
70	P9/I- $\overline{\text{CST1}}$	I/O	FL SEGMENT output P9/DECK1 cassette detect switch data input
71	P8/I- $\overline{\text{REA}}$	I/O	FL SEGMENT output P8/DECK2 side A record OK switch data input
72	VDD4	–	Power supply input
73	P7/I- $\overline{\text{REV2}}$	I/O	FL SEGMENT output P7/DECK2 REVERSE mode input to diode
74	P6/I- $\overline{\text{REV1}}$	I/O	FL SEGMENT output P6/DECK1 REVERSE mode input to diode
75	P5/NO_ECO	I/O	FL SEGMENT output P5/NO ECO MODE input to diode
76 ~ 79	P4 ~ P1	O	FL SEGMENT output P4 ~ P1
80	O-CD CLOSE	O	CD TRAY CLOSE data output
81	O-CD OPEN	O	CD TRAY OPEN data output
82	NC	–	Not connected
83	I-JOG_A	I	Rotary encoder A input (JOG)
84	I-JOG_B	I	Rotary encoder B input (JOG)
85	O-DISH_FWD	O	CD turntable forward rotation output
86	O-DISH_REV	O	CD turntable reverse rotation output
87	O-PLL_CE	O	PLL IC chip enable output
88	O- $\overline{\text{KSCAN}}$	O	Switch SCAN timing output
89	VSS2	–	GND
90	VDD2	–	Power supply input
91	LED- $\overline{\text{STBY}}$	O	STAND BY LED (Echo mode) output
92	O- $\overline{\text{MOTOR}}$	O	DECK MOTOR $\overline{\text{ON}}$ /OFF output
93	O- $\overline{\text{SOL1}}$	O	DECK1 solenoid output
94	O- $\overline{\text{SOL2}}$	O	DECK2 solenoid output
95	O-CD-DATA	O	CD DATA output
96	O-CD-LED	O	CD LED output
97	O-CD CLK	O	CD clock output
98	O-CD CE	O	CD chip enable output
99	I-RDS_DATA	I	RDS data input
100	O-PLL_CLK	O	PLL IC CLOCK output

# ADJUSTMENT

- < TUNER SECTION >
- 1. Clock frequency Check**  
 Settings : • Test tape : TP2  
 Method : Set to AM 1602kHz and check that the test point is 2052kHz  $\pm$  45Hz.
  - 2. MW VT Check**  
 Settings : • Test point : TP1 (VT)  
 Method : Set to MW 1602kHz, 531kHz and check that the test point is less than 8.0V (1602kHz) and more than 0.6V (531kHz).
  - 3. LW VT Adjustment**  
 Settings : • Test point : TP1 (VT)  
 • Adjustment location : L942  
 Method : Set to LW 144kHz and adjust L942 so that the test point is 1.3V  $\pm$  0.05V.  
 Then set to LW 290kHz and check that the test point is less than 8.0V.
  - 4. FM VT Check**  
 Settings : • Test point : TP1 (VT)  
 Method : Set to FM 87.5MHz, 108.0MHz and check that the test point is more than 0.5V (87.5MHz) and less than 8.0V (108.0MHz).
  - 5. MW Tracking Adjustment**  
 Settings : • Test point : TP8(Lch), TP9(Rch)  
 • Adjustment location : L951 (1/3) ..... 999kHz  
 Method : Set to MW 999kHz and adjust L951 (1/3) so that the level at the test point becomes maximum.
  - 6. LW Tracking Adjustment**  
 Settings : • Test point : TP8(Lch), TP9(Rch)  
 • Adjustment location : L941, TC942  
 Method : Set to TC943 to center position.  
 Set to LW 144kHz and adjust L941 so that the level at test point becomes maximum.  
 Then set to LW 290kHz and adjust TC942 so that the level at test point becomes maximum.
  - 7. FM Tracking Check**  
 Settings : • Test point : TP8(Lch), TP9(Rch)  
 Method : Set to FM 98.0MHz and check that the test point is less than 13dB $\mu$ V.
  - 8. AM IF Adjustment**  
 Settings : • Test point : TP8(Lch), TP9(Rch)  
 • Adjustment location : L802 ..... 999kHz
  - 9. DC Balance / Mono Distortion Adjustment**  
 Settings : • Test point : TP3, TP4 (DC Balance)  
 • Adjustment location : L801  
 • Input level : 60dB $\mu$ V  
 Method : Set to FM 98.0MHz and adjust L801 so that the voltage between TP3 and TP4 becomes 0V  $\pm$  0.3V.  
 Next, check that the distortion is less than 1.3%.
- < DECK SECTION >
- 10. Tape Speed Adjustment (DECK 2)**  
 Settings : • Test tape : TTA-100  
 • Test point : TP8(Lch), TP9(Rch)  
 • Adjustment location : SFR1  
 Method : Play back the test tape and adjust SFR1 so that the frequency counter reads 3000Hz  $\pm$  5Hz and  $\pm$  45Hz (REV) with respect to forward speed.
  - 11. Head Azimuth Adjustment (DECK 1, DECK 2)**  
 Settings : • Test tape : TTA-330  
 • Test point : TP8(Lch), TP9(Rch)  
 • Adjustment location : Head azimuth adjustment screw  
 Method : Play back (FWD) the 8kHz signal of the test tape and adjust screw so that the output becomes maximum. Next, perform on REV PLAY mode.
  - 12. PB Frequency Response Check (DECK 1, DECK 2)**  
 Settings : • Test tape : TTA-300  
 • Test point : TP8(Lch), TP9(Rch)  
 Method : Play back the 315Hz and 8kHz signals of the test tape and check that the output ratio of the 8kHz signal with respect to that of the 315Hz signal is within 5dB.
  - 13. PB Sensitivity Check (DECK 1, DECK 2)**  
 Settings : • Test tape : TTA-200  
 • Test point : TP8(Lch), TP9(Rch)  
 Method : Play back the test tape and check that the output level of the test point is 140mV  $\pm$  3dB.
  - 14. REC/PB Frequency Response Adjustment (DECK 2)**  
 Settings : • Test tape : TTA-602  
 • Test point : TP8(Lch), TP9(Rch)  
 • Input signal : 1kHz / 8kHz (LINE IN)  
 • Adjustment location : SFR451 (Lch) SFR452 (Rch)  
 Method : Apply a 1kHz signal and REC mode. Then adjust OSC attenuator so that the output level at the TP8, TP9 becomes -20VU. Record and play back the 1kHz and 8kHz signals and adjust SFRs so that the output of the 8kHz signals becomes 0dB  $\pm$  0.5dB with respect to that of the 1kHz signal.
  - 15. REC/PB Sensitivity Check (DECK 2)**  
 Settings : • Test tape : TTA-602  
 • Test point : TP8(Lch), TP9(Rch)  
 • Input signal : 1kHz (LINE IN)  
 Method : Apply a 1kHz signal and REC mode. Then adjust OSC attenuator so that the output level at TP8, TP9 becomes 0VU. Record and play back the 1kHz signals and check that the output is -2dB  $\pm$  3.0dB.
- < FRONT SECTION >
- 16.  $\mu$ -CON OSC Adjustment**  
 Settings : • Test point : TP7 and GND  
 • Adjustment location : L331  
 Method : Insert AC plug while pressing POWER and TUNER function keys. Adjust L331 so that the frequency at the test point is 153.84kHz  $\pm$  0.15kHz.

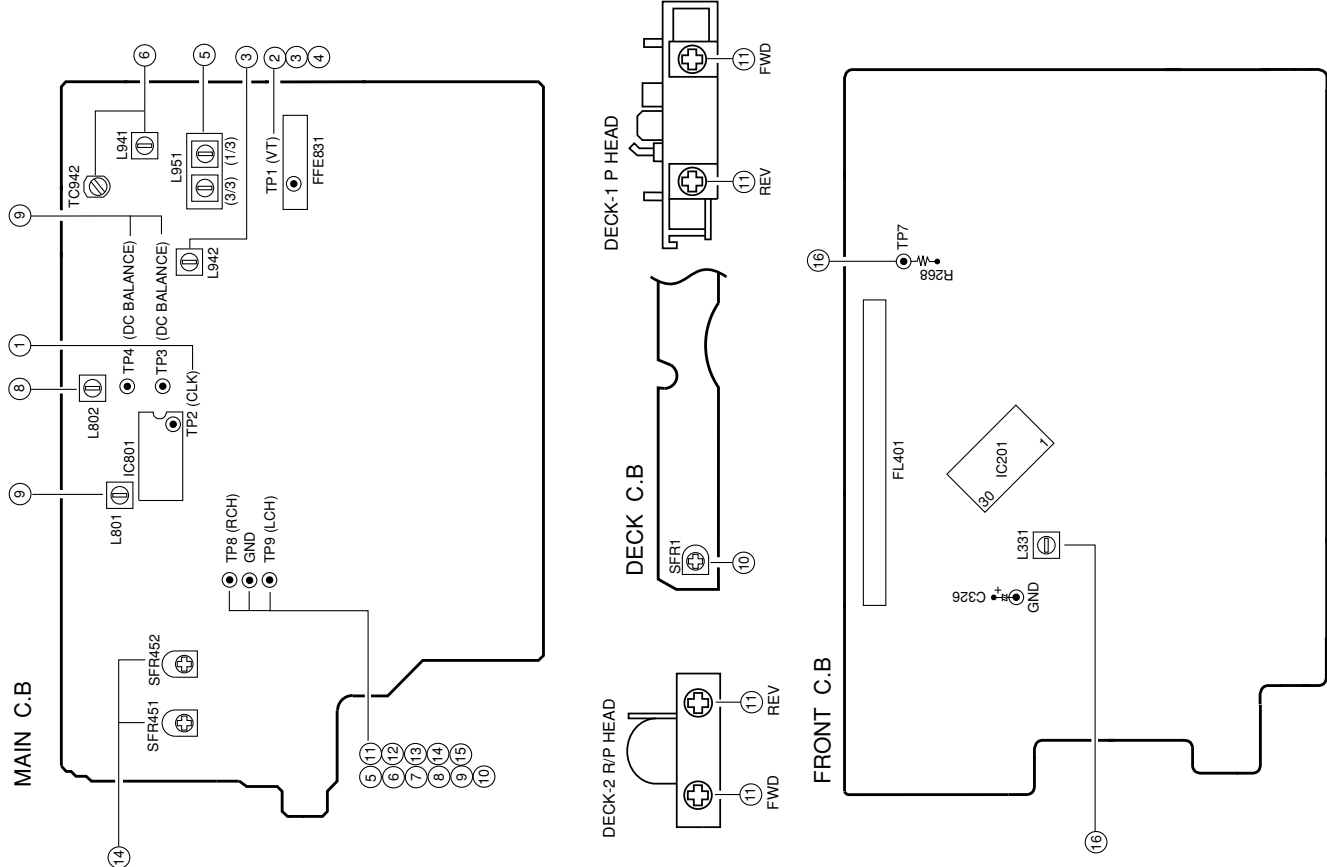

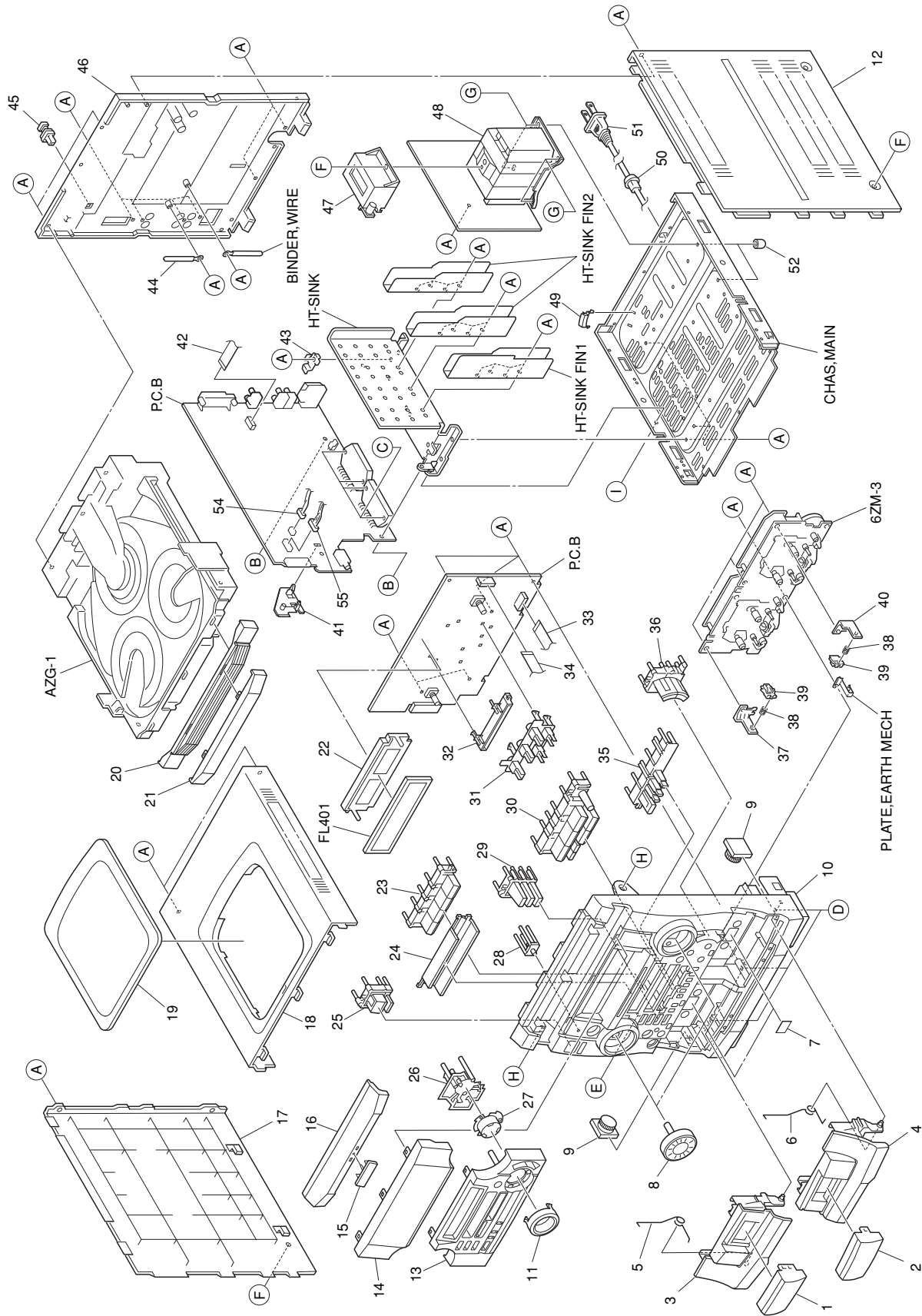

# MECHANICAL MAIN PARTS LIST 1/1

DESCRIPTIONで判断できない物は "REFERENCE NAME LIST" を参照してください。  
 If can't understand for Description please kindly refer to "REFERENCE NAME LIST".

REF. NO	PART NO.	KANRI NO.	DESCRIPTION	REF. NO	PART NO.	KANRI NO.	DESCRIPTION
1	8A-NF8-014-010		WINDOW, CASS 1	34	88-913-301-110		FF-CABLE, 13P-1.25
2	8A-NF8-015-010		WINDOW, CASS 2	35	8A-NF8-038-110		KEY, CD EDIT E<42>
3	8A-NF8-042-010		BOX, CASS 1H	35	8A-NF8-028-110		KEY, CD EDIT U<40>
4	8A-NF8-004-010		BOX, CASS 2 U	36	8A-NF8-029-110		KEY, OPEN
5	8A-NF8-207-010		SPR-T, EJECT 1	37	87-NF4-216-010		HLDL, LOCK 1
6	8A-NF8-208-010		SPR-T, EJECT 2	38	86-NF9-224-010		SPR-C, LOCK
7	81-532-080-010		LBL, CASS-COMPT	39	82-NF5-229-010		PLATE, LOCK(*)
8	8A-NF8-019-010		KNOB, RTRY JOG	40	87-NF4-217-110		HLDL, LOCK 2
9	8A-NF8-209-010		OIL-DMPR, 120	41	8A-NF8-206-010		HLDL, PWB M
10	8A-NF8-033-010		CABI, FR E40	42	88-906-251-110		FF-CABLE, 6P 1.25
11	8A-NF8-034-010		PANEL, DIRECT	43	8A-NF8-205-010		HLDL, IC
12	8A-NF8-008-010		PANEL, RIGHT V-2	44	87-064-185-010		HLDL, WIRE PVC 0.5
13	8A-NF8-045-010		PANEL, FR E<42>	45	84-ZG1-245-210		CAP, OPTICAL
13	8A-NF8-048-010		PANEL, FR K<40>	46	8A-NF8-079-010		CABI, REAR 40 EZSM<40>
14	8A-NF8-091-010		WINDOW, DISP E40<40>	46	8A-NF8-080-010		CABI, REAR 42 EZSM R<42>
14	8A-NF8-092-010		WINDOW, DISP E42<42>	47	8A-DB8-209-010		HLDL, PWB PT
15	87-CE3-023-010		BADGE, AIWA 30N SILV	48	8A-NFJ-608-010		PT, ANF-8 EZ (2)
16	8A-NF8-009-110		PANEL, CD	49	87-NF4-221-010		HLDL, CABLE
17	8A-NF8-007-010		PANEL, LEFT V-2	50	87-085-185-010		BUSHING, AC CORD(E) CM-22B
18	8A-NF8-005-010		PANEL, TOP	51	87-A80-157-010		AC CORD ASSY, E BLK CC
19	8A-NF8-006-010		WINDOW, TOP	52	8Z-NB8-240-010		COVER, PL
20	8A-NF8-010-010		PANEL, TRAY	54	87-NF6-615-010		CONN ASSY, 3P PB
21	8A-NF8-011-010		WINDOW, TRAY	55	87-A60-625-010		CONN, 8P V 2MM JMT
22	88-NF8-205-010		GUIDE, FL	A	87-067-703-010		BVT2+3-10 W/O SLOt
23	8A-NF8-020-010		KEY, FUN	B	87-NF4-224-010		S-SCREW, IT3B+3-8 CU
24	8A-NF8-018-110		REFLECTOR, FUN	C	87-067-581-010		BVT2+3-15 W/O SLOt
25	8A-NF8-016-010		KEY, POWER	D	87-067-688-010		BVTT+3-6
26	8A-NF8-031-110		KEY, DISC	E	87-723-096-410		QT2+3-10 W/O SLOt BLK
27	8A-NF8-032-010		CAP, DISC	F	87-067-641-010		UTT2+3-8 W/O SLOt BLK
28	8A-NF8-017-010		REFLECTOR, ECO	G	87-078-191-010		S-SCREW, IT+4-10 SWCH12A
29	8A-NF8-022-010		KEY, GEQ	H	87-721-097-410		QT2+3-12 W/O SLOt
30	8A-NF8-036-110		KEY, ASSY OPE REV	I	87-721-096-410		QT2+3-10 W/O SLOt
31	8A-NF8-203-010		GUIDE, OPE REV				
32	8A-NF8-201-010		GUIDE, FUN				
33	88-911-101-110		FF-CABLE, 11P 1.25				

## COLOR NAME TABLE

Basic color symbol	Color	Basic color symbol	Color	Basic color symbol	Color
B	Black	C	Cream	D	Orange
G	Green	H	Gray	L	Blue
LT	Transparent Blue	N	Gold	P	Pink
R	Red	S	Silver	ST	Titan Silver
T	Brown	V	Violet	W	White
WT	Transparent White	Y	Yellow	YT	Transparent Yellow
LM	Metallic Blue	LL	Light Blue	GT	Transparent Green
LD	Dark Blue	DT	Transparent Orange	GM	Metallic Green
YM	Metallic Yellow	DM	Metallic Orange	PT	Transparent Pink

# MECHANISM MAIN PARTS LIST 1/1 <6ZM-3 PR2NM>

DESCRIPTIONで判断できない物は "REFERENCE NAME LIST" を参照してください。  
 If can't understand for Description please kindly refer to "REFERENCE NAME LIST".

REF. NO	PART NO.	KANRI NO.	DESCRIPTION	REF. NO	PART NO.	KANRI NO.	DESCRIPTION
1	86-ZM3-215-110		CHAS ASSY,RS	40	82-ZM3-616-010		RING MAGNET 4
2	86-ZM3-202-110		BASE,HEAD S	41	82-ZM1-216-510		GEAR, REEL
3	86-ZM3-205-010		SPR-C,RPH S	42	82-ZM1-214-010		SPR-T, DIR
4	82-ZM1-333-210		PLATE, LINK2	43	82-ZM1-225-210		GEAR, FR
5	86-ZM3-206-010		SPR-C, EH S	44	82-ZM1-226-010		GEAR, REW
6	87-A90-403-010		HEAD, RPH MS15R	45	82-ZM3-333-310		SLIP DISK ASSY 2
7	82-ZM1-206-910		CHAS, HEAD (DECK R)	46	82-ZM1-338-110		BELT, FR 4
7	86-ZM3-201-010		CHAS, HEAD S (DECK L)	47	09-001-420-010		FLY-WHL, R ASSY (DECK R)
8	87-045-347-010		MOT, SHU2L 70	47	82-ZM1-237-610		FLY-WHL ASSY, RW (DECK L)
9	82-ZM1-269-210		SPR-T, BRG	48	82-ZM1-259-210		SPR-T, PINCH R
10	82-ZM1-219-110		SPR-T, LINK	49	82-ZM1-341-210		LVR ASSY, PINCH L2
11	86-ZM3-219-010		PLATE, SPACER 0.1	50	82-ZM1-258-210		SPR-T, PINCH L
12	82-ZM3-339-110		SHAFT, COUPLER N3	51	82-ZM1-314-110		PLATE, HEAD
13	87-A90-404-010		HEAD, EH LE15B	52	82-ZM1-208-310		HLDR, HEAD
14	82-ZM3-335-310		PULLEY, COUPLER M3	53	87-A90-366-110		HEAD, PH YK50P-BF414 FPC
15	86-ZM3-203-010		HLDR, MOT S	54	82-ZM1-207-910		GUIDE, TAPE
16	82-ZM1-245-210		HLDR, IC	55	82-ZM1-213-010		SPR-T, HEAD
17	82-ZM1-218-010		SPR-E, HB	56	82-ZM1-210-110		GEAR, H T
18	86-ZM3-214-110		BELT, SBU RR	57	82-ZM1-266-310		LVR, DIR
19	82-ZM1-222-210		LVR, PLAY	A	87-251-071-410		U+2.6-4
20	82-ZM1-217-410		REEL TABLE	B	80-ZM6-243-010		SH 1.75-3.6-0.5 SLT
21	82-ZM1-244-510		SPR-C, BT	C	82-ZM3-334-010		PW 2.16-6-0.4
22	82-ZM1-285-410		SPR-C, BT L	D	80-ZM6-207-010		V+1.6-7
23	82-ZM1-257-010		SPR-T, CAS	E	85-ZM3-202-010		S-SCREW, TG
24	82-ZM3-221-210		PULLEY, MOT 2M	F	82-ZM1-288-010		SH, 1.63-3.2-0.5 SLT
25	82-ZM1-242-010		LVR, CAS	G	87-B10-043-010		W-P, 0.99-4-0.25 SLT
26	82-ZM1-243-010		LVR, STOP	H	82-ZM3-222-010		S-SCREW, SHILD PLATE
27	82-ZM1-344-210		LVR ASSY, PINCH R2	I	86-ZM3-209-010		S-SCREW, AZIMUTH S
28	86-ZM3-204-010		SPR-T, PINCH S	J	86-ZM3-207-010		S-SCREW, RPH
29	82-ZM1-240-110		LVR, REC(*)	K	86-ZM3-208-110		S-SCREW, EH
30	86-ZM3-210-010		BELT, PS	L	86-ZM3-218-110		S-SCREW, EH 2
31	82-ZM1-234-310		FLY-WHL, L ASSY	M	86-ZM4-206-010		S-SCREW, AZIMUTH L
32	82-ZM3-305-310		GEAR, CAM M2(*)	N	87-761-073-410		VFT2+2.6-8 W/O SLOT
33	82-ZM1-227-310		LVR, TRIG	O	86-ZM3-213-010		S-SCREW, HLDR MOT S
34	82-ZM3-306-110		LVR, FR M2				
35	82-ZM1-265-310		SPR-E, TRIG				
36	86-ZM1-206-010		BELT, MAIN L				
37	82-ZM1-255-310		SPR-E, LVR DIR				
38	82-ZM1-322-010		SPR-T, FR 60				
39	82-ZM1-220-210		GEAR, IDLER				



MECHANISM EXPLODED VIEW 1/1 <6ZM-3 PR2NM>

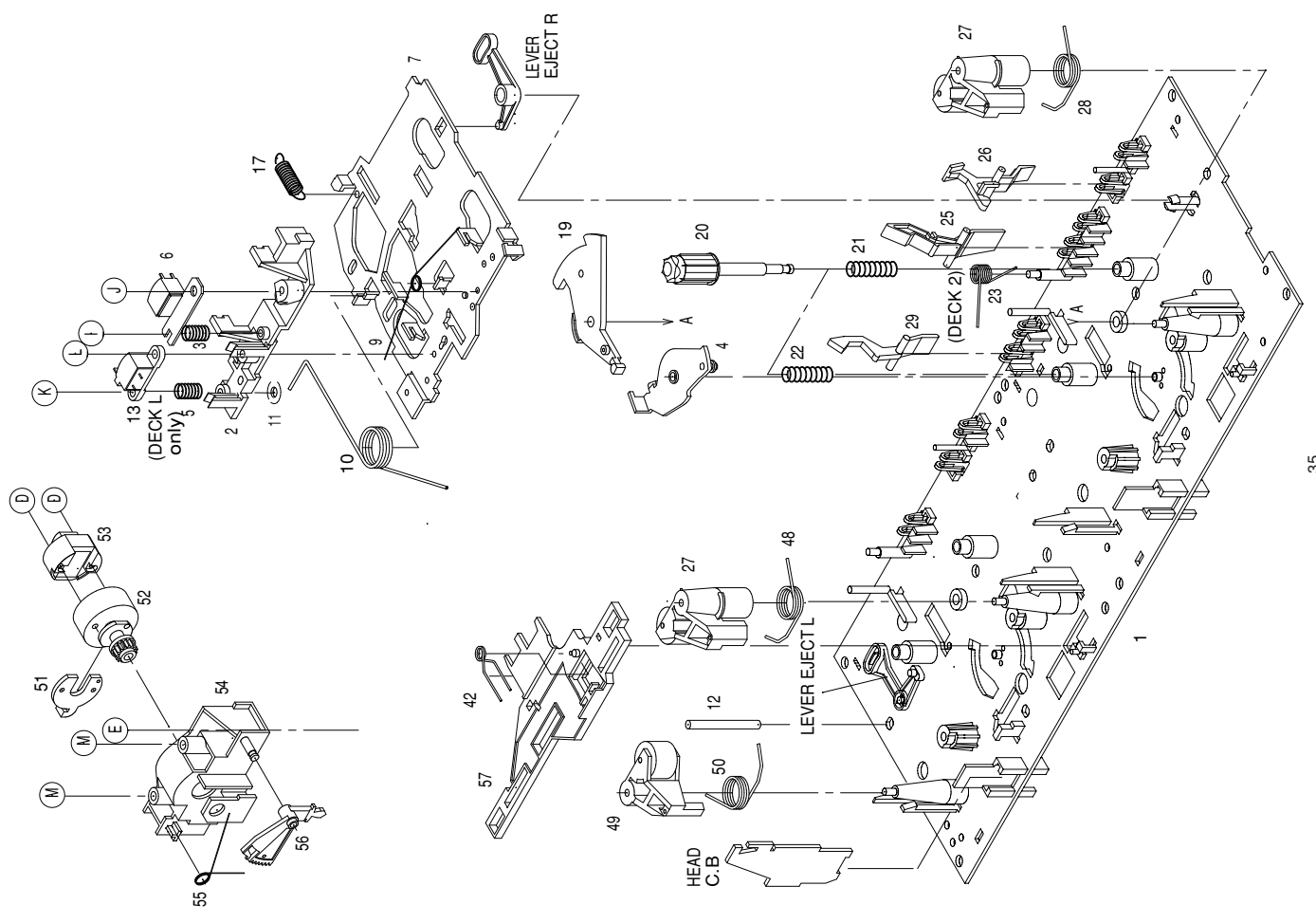
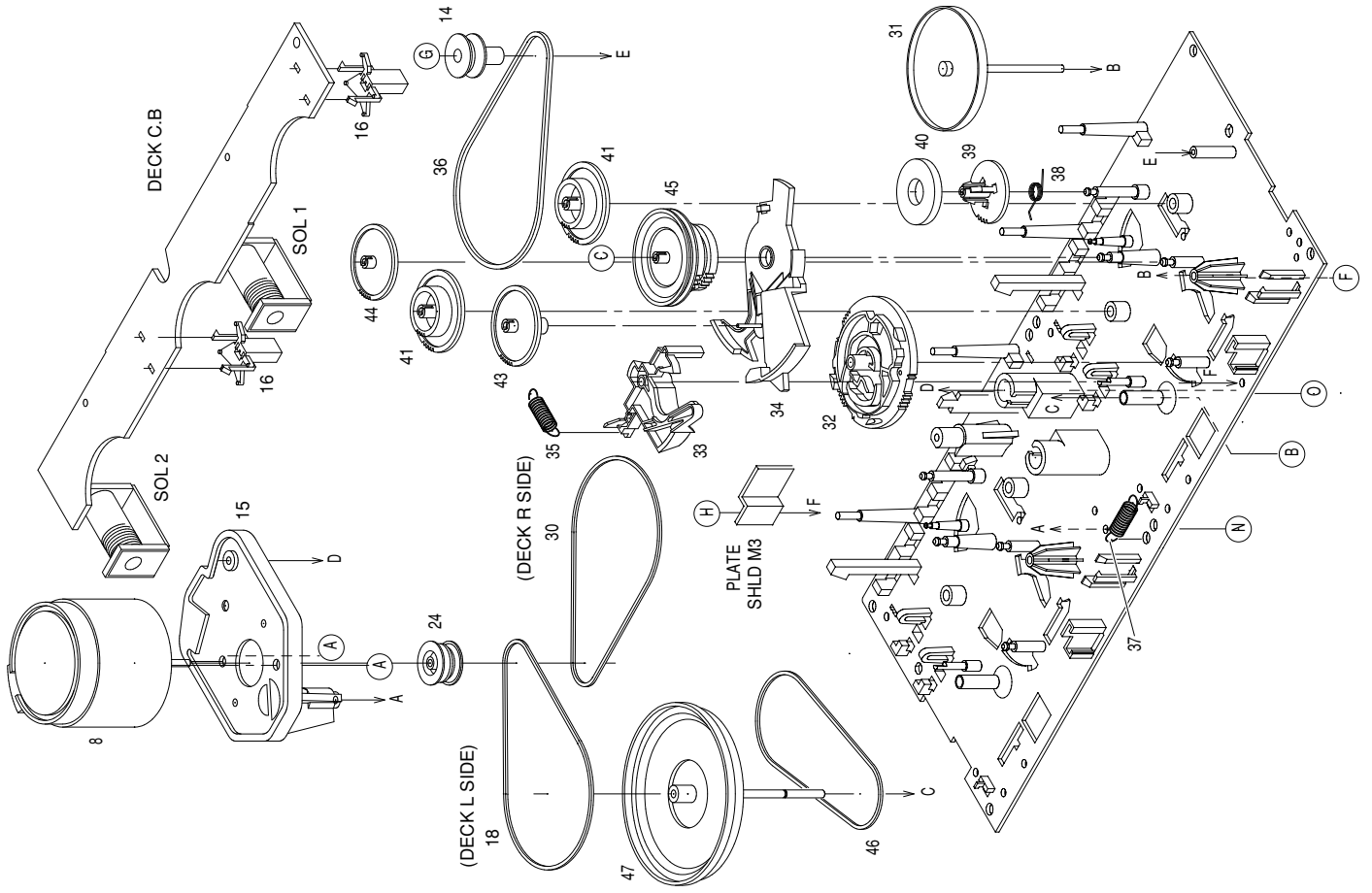

## SPEAKER DISASSEMBLY INSTRUCTIONS

### Type.1

Insert a flat-bladed screwdriver into the position indicated by the arrows and remove the panel. Remove the screws of each speaker unit and then remove the speaker units.

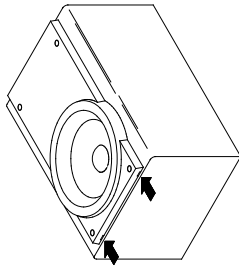

### Type.2

Remove the grill frame and four pieces of rubber caps by pulling out with a flat-bladed screwdriver. Remove the screws from hole where installed rubber caps. Insert a flat-bladed screwdriver into the position indicated by the arrows and remove the panel. Remove the screws of each speaker unit and then remove the speaker units.

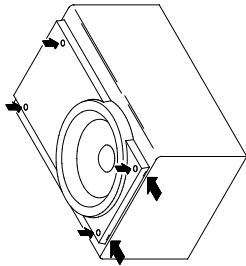

### Type.3

Insert a flat-bladed screwdriver into the position indicated by the arrows and remove the panel. Turn the speaker unit to counter-clockwise direction while inserting a flat-bladed screwdriver into one of the hollows around speaker unit, and then remove the speaker unit. After replacing the speaker unit, install it turning to clockwise direction until "click" sound comes out.

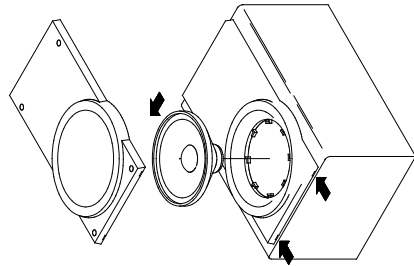

### Type.4

#### TOOLS

- ① Plastic head hammer
- ② (C) flat head screwdriver
- ③ Cut chisel

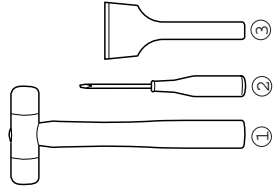

### How to Remove the PANEL, FR

1. Insert the (C) flat head screwdriver tip into the gap between the PANEL, FR and the PANEL, SPKR. Tap the head of the (C) flat head screwdriver with the plastic hammer head, and create the clearance as shown in Fig-1.
2. Insert the cut chisel in the clearance, and tap the head of the cut chisel with plastic hammer as shown in Fig-2, to remove the PANEL, FR.
3. Place the speaker horizontally. Tap head of the cut chisel with plastic hammer as shown in Fig-3, and remove the PANEL, FR completely.

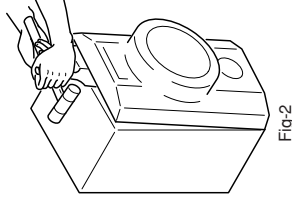
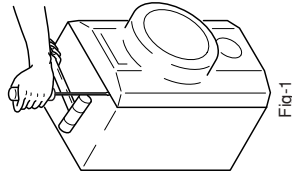

Fig-1

Fig-2

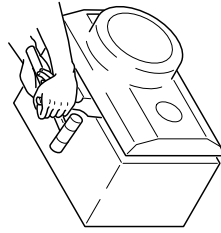

Fig-3

### How to Attach the PANEL, FR

Attach the PANEL, FR to the PANEL, SPKR. Tap the four corners of the PANEL, FR with the plastic hammer to fit the PANEL, FR into the PANEL, SPKR completely.

## SPEAKER PARTS LIST <SX-NSZ51>

DESCRIPTIONで判断できない物は"REFERENCE NAME LIST"を参照してください。  
If can't understand for Description please kindly refer to "REFERENCE NAME LIST".

REF. NO	PART NO.	KANRI NO.	DESCRIPTION
1	8A-NSJ-002-010		PANEL,FR L
2	8A-NSJ-001-010		PANEL,FR R
3	8A-NSJ-004-010		GRILLE,FRAME
4	8A-NSJ-003-010		GRILLE,FRAME ASSY
5	8A-NSJ-005-010		NET,
6	8A-NSJ-008-010		PROTECTOR,TWA
7	87-NS7-611-010		CORD,SPKR
8	88-NSJ-608-010		SPKR, CERAMIC
9	8A-NSK-602-010		SPKR, W 140
10	8A-NSK-604-010		SPKR, W 60
11	8A-NSJ-006-010		BADGE,AIMA S35

## SPEAKER PARTS LIST <SX-NSZ53>

DESCRIPTIONで判断できない物は"REFERENCE NAME LIST"を参照してください。  
If can't understand for Description please kindly refer to "REFERENCE NAME LIST".

REF. NO	PART NO.	KANRI NO.	DESCRIPTION
1	8A-NSJ-002-010		PANEL,FR L
2	8A-NSJ-001-010		PANEL,FR R
3	8A-NSJ-004-010		GRILLE,FRAME
4	8A-NSJ-024-010		GRILLE,FRAME ASSY L
5	8A-NSJ-008-010		PROTECTOR,TWA
6	87-NS7-611-010		CORD,SPKR
7	8A-NSK-602-010		SPKR, W 140
8	8A-NSK-604-010		SPKR, W 60
9	88-NSJ-608-010		SPKR, CERAMIC
10	8A-NSJ-006-010		BADGE,AIMA S35



**アイワ株式会社** 〒110-8710 東京都台東区池之端1-2-11 ☎03(3827)3111 (代表)  
**AIWA CO.,LTD.** 2-11, IKENOHATA 1-CHOME, TAITO-KU, TOKYO 110, JAPAN TEL:03 (3827) 3111