

# SERVICE MANUAL

COMPACT DISC/  
STEREO CASSETTE RECEIVER

BASIC TAPE MECHANISM : 2ZM-3MK2 PR4NM(HA)  
BASIC TAPE MECHANISM : 6ZM-3 PR2NM(K/EZ)  
BASIC CD MECHANISM : AZG-1 YZD8RDM(K)  
BASIC CD MECHANISM : AZG-1 ZD8RDM(EZ/HA)

SYSTEM	CD CASSEIVER	SPEAKER	REMOTE CONTROLLER
NSX-SZ50	CX-NSZ50	SX-WNSZ50	RC-ZAS01
NSX-SZ52	CX-NSZ52	SX-WNSZ52	RC-ZAS01

- This Service Manual is the "Revision Publishing" and replaces "Simple Manual" NSX-SZ50 <EZ,K,HA> & NSX-SZ52<EZ> (S/M Code No. 09-002-424-6T2).
- If requiring information about the CD mechanism, see Service Manual of AZG-1, (S/M Code No. 09-001-335-3N6).

# SPECIFICATIONS

## Main unit CX-NSZ50, CX-NSZ52

### FM tuner section

<b>Tuning range</b>	87.5 MHz to 108 MHz
<b>Usable sensitivity (IHF)</b>	16.8 dBf <EZ, K> 13.2 dBf <HA>
<b>Antenna terminal</b>	75 ohms (unbalanced)

### AM (MW) tuner section

<b>Tuning range</b>	531 kHz to 1602 kHz (9 kHz step) 530 kHz to 1710 kHz (10 kHz step)
<b>Usable sensitivity</b>	350 μV/m
<b>Antenna</b>	Loop antenna

### LW tuner section <EZ, K>

<b>Tuning range</b>	144 kHz to 290 kHz
<b>Usable sensitivity</b>	1400 μV/m
<b>Antenna</b>	Loop antenna

### Amplifier section

#### Mid-high frequency amplifier

<b>Power output</b>	Rated: 20 W + 20 W (8 ohms, T.H.D. 1 %, 1 kHz/DIN 45500) Reference : 25 W + 25 W (8 ohms, T.H.D. 10 %, 1 kHz/DIN 45324) DIN MUSIC POWER: 40 W + 40 W<EZ>
<b>Total harmonic distortion</b>	0.1 % (10 W, 1 kHz, 8 ohms, DIN AUDIO)

#### Low frequency amplifier

<b>Power output</b>	Rated: 60 W + 60 W (6 ohms, T.H.D. 1 %, 130 Hz/DIN 45500) Reference : 75 W + 75 W (6 ohms, T.H.D. 10 %, 130 Hz/DIN 45324) DIN MUSIC POWER: 130 W + 130 W <EZ>
<b>Total harmonic distortion</b>	0.1 % (30W, 130 Hz, 6 ohms, DIN AUDIO)

#### Inputs

VIDEO/AUX: 500 mV  
MIC: 1.0 mV (10 k ohms) <HA>

#### Outputs

SPEAKERS HIGH FREQ:  
accept speakers of 8 ohms or more  
SPEAKERS LOW FREQ:  
accept speakers of 6 ohms or more  
SURROUND SPEAKERS:  
accept speakers of 8 ohms to 16 ohms <EZ, K>  
PHONES (stereo jack): accepts headphones of 32 ohms or more

### Cassette deck section

<b>Track format</b>	4 tracks, 2 channels stereo
<b>Frequency response</b>	50 Hz – 15000 Hz
<b>Recording system</b>	AC bias
<b>Heads</b>	Deck 1: Playback head x 1 Deck 2: Recording/playback head x 1, erase head x 1

### Compact disc player section

<b>Laser</b>	Semiconductor laser (λ = 780 nm)
<b>D-A converter</b>	1 bit dual
<b>Signal-to-noise ratio</b>	85 dB (1 kHz, 0 dB)
<b>Harmonic distortion</b>	0.05 % (1 kHz, 0 dB)
<b>Wow and flutter</b>	Unmeasurable

### General

<b>Power requirements</b>	230 V AC, 50 Hz <EZ, K> 120 V/220-230 V/240 V AC switchable, 50/60 Hz <HA>
<b>Power consumption</b>	150 W <EZ,K> 130 W <HA>
<b>Power consumption in standby mode</b>	If the power-economizing mode is ECO OFF: 20 W If the power-economizing mode is ECO ON or ECO AUTO: 0.9 W
<b>Dimensions of main unit (W x H x D)</b>	260 x 326 x 345 mm
<b>Weight of main unit</b>	9.0 kg

### Speaker system SX-WNSZ50, SX-WNSZ52

<b>Speaker system</b>	3 way, Built-in subwoofer (magnetic shielded type)
<b>Speaker units</b>	Subwoofer: 160 mm cone type Full range: 100 mm cone type Super tweeter: 20 mm ceramic type
<b>Impedance</b>	6 ohms/8 ohms
<b>Sensitivity</b>	87 dB/W/m
<b>Dimensions (W x H x D)</b>	240 x 324 x 271 mm
<b>Weight</b>	4.8 kg

- Design and specifications are subject to change without notice.
- The word "BBE" and the "BBE symbol" are trademarks of BBE Sound, Inc.
- Under license from BBE Sound, Inc.

## ACCESSORIES LIST

DESCRIPTIONで判断できない物は "REFERENCE NAME LIST" を参照してください。  
If can't understand for Description please kindly refer to "REFERENCE NAME LIST".

REF. NO	PART NO.	KANRI NO.	DESCRIPTION	REF. NO	PART NO.	KANRI NO.	DESCRIPTION
1	8A-NF8-902-010	IB, LH (ESP) M<HA>		3	87-006-225-010		ANT, LOOP ANT NC2
1	8A-NF8-905-010	IB, K (E) E<K>		4	87-043-115-010		FEEDER-ANT, FM<HA>
1	8A-NF8-926-010	IB, EZ (9L) M<0EZ>		4	87-A90-118-010		ANT, WIRE FM (Z) <0EZ, 2EZ, K>
1	8A-NF8-936-010	IB, EZ (9L) M- RDS<2EZ>					
2	8Z-NF8-702-010	RC UNIT, RC-ZAS01					

## PROTECTION OF EYES FROM LASER BEAM DURING SERVICING

This set employs laser. Therefore, be sure to follow carefully the instructions below when servicing.

### WARNING!

WHEN SERVICING, DO NOT APPROACH THE LASER EXIT WITH THE EYE TOO CLOSELY. IN CASE IT IS NECESSARY TO CONFIRM LASER BEAM EMISSION. BE SURE TO OBSERVE FROM A DISTANCE OF MORE THAN 30cm FROM THE SURFACE OF THE OBJECTIVE LENS ON THE OPTICAL PICK-UP BLOCK.

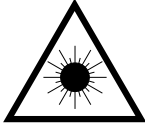

- Caution: Invisible laser radiation when open and interlocks defeated avoid exposure to beam.
- Advarsel: Usynlig laserstråling ved åbning, når sikkerhedsafbrydere er ude af funktion. Undgå udsættelse for stråling.

### VAROITUS!

Laiteen Käyttäminen muulla kuin tässä käyttöohjeessa mainitulla tavalla saattaa altistaa käyt-täjän turvallisuusluokan 1 ylit-tävälle näkymättömälle lasersäteilylle.

### WARNING!

Om apparaten används på annat sätt än vad som specificeras i denna bruksanvisning, kan användaren utsättas för osynlig laserstråling, som överskrider gränsen för laserklass 1.

### CAUTION

Use of controls or adjustments or performance of procedures other than those specified herein may result in hazardous radiation exposure.

### ATTENTION

L'utilisation de commandes, réglages ou procédures autres que ceux spécifiés peut entraîner une dangereuse exposition aux radiations.

### ADVARSEL!

Usynlig laserstråling ved åbning, når sikkerhedsafbrydere er ude af funktion. Undgå udsættelse for stråling.

This Compact Disc player is classified as a CLASS 1 LASER product.

The CLASS 1 LASER PRODUCT label is located on the rear exterior.

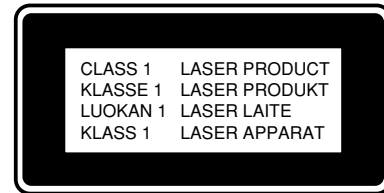

## Precaution to replace Optical block (KSM-880CAB)

Body or clothes electrostatic potential could ruin laser diode in the optical block. Be sure ground body and workbench, and use care the clothes do not touch the diode.

- 1) After the connection, remove solder shown in the right figure.

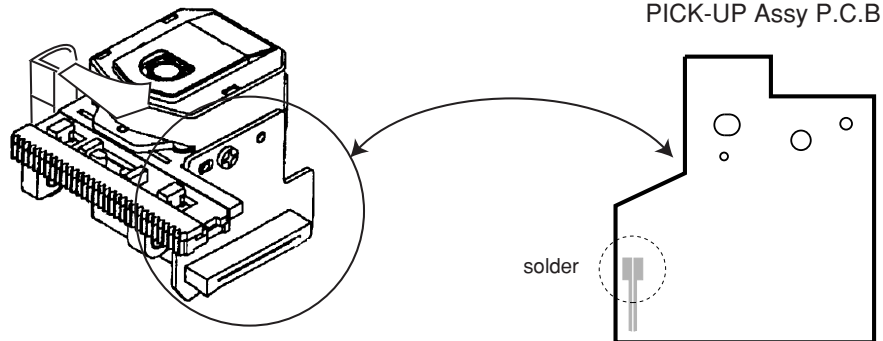

# NOTE ON BEFORE STARTING REPAIR

## 1. Forced discharge of electrolytic capacitor of power supply block

When repair is going to be attempted in the set that uses relay circuit in the power supply block, electric potential is kept charged across the electrolytic capacitors (C101, 102) even though AC power cord is removed. If repair is attempted in this condition, secondary defect can occur.

In order to prevent the secondary trouble, perform the following measures before starting repair work.

### Discharge procedure

- ① Remove the AC power cord.
- ② Connect a discharging resistor at an end of lead wire that has clips at both ends. Connect the other end of the lead wire to metal chassis.
- ③ Contact the other end of the discharging resistor to the positive (+) side (+VH) of C101. (For two seconds)
- ④ Contact the same end of the discharging resistor as step 3 to the negative (-) side (-VH) of C102 in the same way. (For two seconds)
- ⑤ Check that voltage across C101 and C102 has decreased to 1 V or less using a multimeter or an oscilloscope.

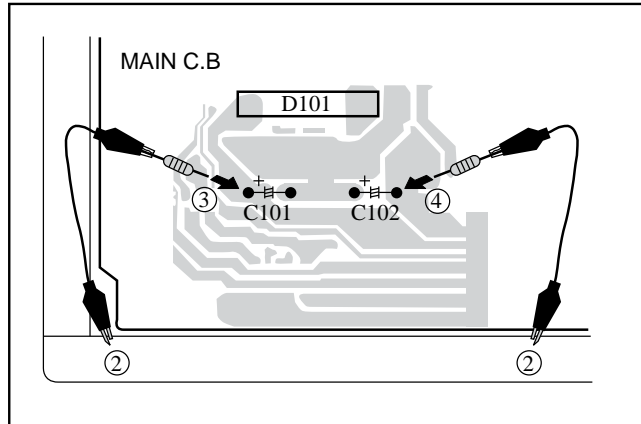

Select a discharging resistor referring to the following table.

Charging voltage (V) (C101, 102)	Discharging resistor ( )	Rated power (W)	Parts number
25-48	100	3	87-A00-247-090
49-140	220	5	87-A00-232-090

**Note:** The reference numbers (C101, C102) of the electrolytic capacitors can change depending on the models. Be sure to check the reference numbers of the charging capacitors on schematic diagram before starting the discharging work.

## 2. Check items before exchanging the MICROCOMPUTER

Be sure to check the following items before exchanging the MICROCOMPUTER. Exchange the MICROCOMPUTER after confirming that the MICROCOMPUTER is surely defective.

### 2-1. Regarding the HOLD terminal of the MICROCOMPUTER

When the HOLD terminal (INPUT) of the MICROCOMPUTER is “H”, the MICROCOMPUTER is judged to be operating correctly. When this terminal is “L”, the main power cannot be turned on. Therefore, be sure to check the terminal voltage of the HOLD terminal before exchange.

When the MICROCOMPUTER is not defective, the HOLD terminal can also go “L” when the POWER AMPLIFIER has any abnormalities that triggers the abnormality detection circuit on the MAIN C. B. that sets the HOLD terminal to “L”.

#### • Good or no good judgement of the MICROCOMPUTER

- ① Turn on the AC main power.
- ② Confirm that the main power is turned on and the HOLD terminal of the MICROCOMPUTER keeps the “H” level or not.
- ③ When the HOLD terminal is “L” level, the abnormality detection circuit is judged to be working correctly and the MICROCOMPUTER is judged to be good.

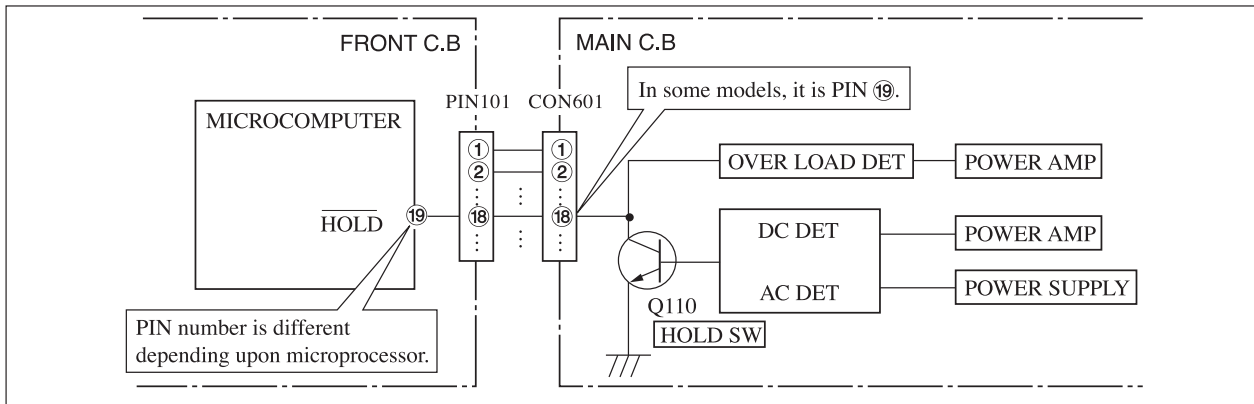

Fig-2-1

In such a case, check also if the POWER AMPLIFIER circuit or power supply circuit has any abnormalities or not.

## 2-2. Regarding reset

There are cases that the machine does not work correctly because the MICROCOMPUTER is not reset even though the AC power cord is re-inserted, or the software reset (pressing the STOP key + POWER key) is performed.

When the above described phenomenon occurs, it can lead to wrong judgement as if the MICROCOMPUTER is defective and to exchange the MICROCOMPUTER. In such a case, perform the forced-reset by the following procedure and check good or no good of the MICROCOMPUTER.

- ① Remove the AC power cord.

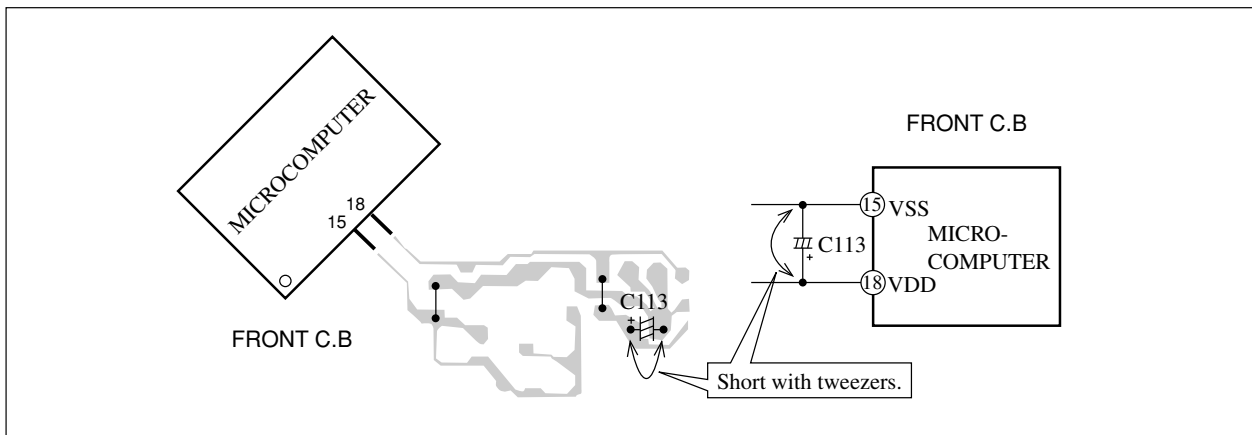

Fig-2-2

- ② Short both ends of the electrolytic capacitor C113 that is connected to VDD of the MICROCOMPUTER with tweezers.
- ③ Connect the AC power cord again. If the MICROCOMPUTER returns to the normal operation, the MICROCOMPUTER is good.

**Note:** The reference number or MICROCOMPUTER pin number of transistor (Q110) and electrolytic capacitor (C113) can change depending on the models. Be sure to check the reference numbers on schematic diagram before starting the discharging work.

## 2-3. Confirmation of soldering state of MICROCOMPUTER

Check the soldering state of the MICROCOMPUTER in addition to the above described procedures. Be sure to exchange the MICROCOMPUTER after surely confirming that the trouble is not caused by poor soldering but the MICROCOMPUTER itself.

# ELECTRICAL MAIN PARTS LIST

DESCRIPTIONで判断できない物は "REFERENCE NAME LIST" を参照してください。  
 If can't understand for Description please kindly refer to "REFERENCE NAME LIST".

REF. NO	PART NO.	KANRI NO.	DESCRIPTION	REF. NO	PART NO.	KANRI NO.	DESCRIPTION
<b>IC</b>							
	87-020-454-010	IC, DN6851		C0003	87-012-368-080		C-CAP, S 0.1-50 Z F
	87-A21-417-010	IC, STRK490-310		C0004	87-012-368-080		C-CAP, S 0.1-50 Z F
	8A-NF8-625-030	C-IC, LC866548V-****<K>		C0005	87-012-368-080		C-CAP, S 0.1-50 Z F
	8A-NF8-611-010	C-IC, LC866560W-5P19<2EZ>		C0006	87-012-368-080		C-CAP, S 0.1-50 Z F
	8A-NF8-612-010	C-IC, LC866548V-5P03<0EZ, HA>		C0009	87-012-368-080		C-CAP, S 0.1-50 Z F
	87-A21-396-010	IC, STK490-040		C0010	87-012-368-080		C-CAP, S 0.1-50 Z F
	87-A21-629-010	IC, SPS-442-1-N<K>		C0011	87-012-368-080		C-CAP, S 0.1-50 Z F
	87-A21-482-010	IC, RPM6938-H4<EXCEPT K>		C0012	87-012-368-080		C-CAP, S 0.1-50 Z F
	87-A21-419-040	C-IC, NJM14558MD-TE2		C0015	87-012-368-080		C-CAP, S 0.1-50 Z F
	87-A21-577-040	C-IC, M61506FP<K>		C0016	87-012-368-080		C-CAP, S 0.1-50 Z F
	87-A21-023-040	C-IC, BA3835F<EXCEPT K>		C0017	87-012-368-080		C-CAP, S 0.1-50 Z F
	87-A21-401-040	C-IC, M61503FP		C0018	87-012-368-080		C-CAP, S 0.1-50 Z F
	87-070-289-040	C-IC, BU2092F		C0019	87-016-520-000		CAP, E 3300-65 M SMG
	87-A21-415-010	IC, LA1843		C0020	87-016-520-000		CAP, E 3300-65 M SMG
	87-A20-440-040	C-IC, BUI920FS<2EZ>		C0021	87-016-051-000		CAP, E 2200-35 M SMG
	87-070-127-110	IC, LC72131D		C0022	87-016-051-000		CAP, E 2200-35 M SMG
				C0023	87-016-658-000		CAP, E 4700-35 M SMG
				C0024	87-016-658-000		CAP, E 4700-35 M SMG
				C0025	87-010-408-080		CAP, E 47-50 M 11L SME
				C0026	87-010-247-080		CAP, E 100-50 M SME
<b>TRANSISTOR</b>							
	87-026-451-080	TR, 2SA933S<HA>		C0030	87-010-430-080		CAP, E 100-63
	87-026-609-080	TR, KTA1266GR		C0031	87-010-263-080		CAP, E 100-10 M 11L SME
	89-213-702-010	TR, 2SB1370E		C0032	87-010-197-080		C-CAP, S 0.01-25 K B C2012
	87-026-610-080	TR, KTC3198GR		C0034	87-010-260-080		CAP, E 47-25 M 11L SME
	87-A30-076-080	C-TR, 2SC3052F		C0035	87-010-380-080		CAP, E 47-16 M 11L SME
	87-A30-075-080	C-TR, 2SA1235F		C0036	87-010-381-080		CAP, E 330-16 M SME
	87-026-245-080	TR, DTC114ES		C0038	87-010-197-080		C-CAP, S 0.01-25 K B C2012
	87-A30-198-080	TR, KTC3199GR		C0060	87-010-403-080		CAP, E 3.3-50 M 11L SME
	87-A30-107-070	C-TR, CMBT5401		C0061	87-010-260-080		CAP, E 47-25 M 11L SME
	87-A30-106-040	C-TR, CMBT5551		C0101	87-010-183-080		C-CAP, S 2700P-50 K B GRM
	87-A30-087-080	C-FET, 2SK2158		C0102	87-010-183-080		C-CAP, S 2700P-50 K B GRM
	87-A30-074-080	C-TR, RT1P 141C		C0103	87-010-545-080		CAP, E 0.22-50 M 11L SME
	87-A30-318-080	TR, CSA952K		C0104	87-010-545-080		CAP, E 0.22-50 M 11L SME
	87-A30-495-080	TR, 2SA1981Y<K>		C0107	87-010-405-080		CAP, E 10-50 M 11L SME
	87-A30-091-080	FET, 2SJ460		C0108	87-010-405-080		CAP, E 10-50 M 11L SME
	87-A30-329-080	TR, CD1585BC		C0111	87-010-405-080		CAP, E 10-50 M 11L SME
	87-A30-090-080	FET, 2SK2541		C0112	87-010-405-080		CAP, E 10-50 M 11L SME
	87-A30-104-080	C-TR, RT1N 441C		C0113	87-010-866-080		CAP, E 10-63 M VX
	87-A30-468-080	C-TR, KRC102S-RTK		C0114	87-010-866-080		CAP, E 10-63 M VX
	87-A30-073-080	C-TR, RT1N 141C<K>		C0119	87-010-197-080		C-CAP, S 0.01-25 K B C2012
	89-333-317-880	TR, 2SC3331 (T/U)		C0120	87-010-197-080		C-CAP, S 0.01-25 K B C2012
	87-A30-269-040	C-FET, 2SJ461-T1		C0123	87-010-176-080		C-CAP, S 680P-50 J<K, 0EZ, 2EZ>
	89-327-143-080	C-TR, 2SC27140		C0124	87-010-176-080		C-CAP, S 680P-50 J<K, 0EZ, 2EZ>
	87-A30-489-080	C-TR, KRA107S		C0125	87-012-368-080		C-CAP, S 0.1-50 Z F
	87-A30-086-070	C-TR, CSD1306E<K, 0EZ, 2EZ>		C0126	87-012-368-080		C-CAP, S 0.1-50 Z F
	89-503-602-080	C-FET, 2SK360E<K, 0EZ, 2EZ>		C0127	87-012-368-080		C-CAP, S 0.1-50 Z F
	87-A30-234-080	TR, CSC4115BC		C0128	87-012-368-080		C-CAP, S 0.1-50 Z F
				C0129	87-010-191-080		C-CAP, S 0.015-50 <K, 0EZ, 2EZ>
				C0130	87-010-191-080		C-CAP, S 0.015-50 <K, 0EZ, 2EZ>
				C0131	87-010-197-080		C-CAP, S 0.01-25 K<K, 0EZ, 2EZ>
<b>DIODE</b>							
	87-A40-393-090	DIODE, 1N5402GW (F20)		C0132	87-010-197-080		C-CAP, S 0.01-25 K<K, 0EZ, 2EZ>
	87-A40-736-080	DIODE, 1N4148M (SEM)		C0133	87-010-186-080		C-CAP, S 4700P-50 K B C2012
	87-A40-547-090	DIODE, D5SBA20		C0140	87-010-182-080		C-CAP, S 2200P-50 K B C2012
	87-A40-455-080	DIODE, RL203 GW		C0141	87-010-196-080		C-CAP, S 0.1-25 Z F C2012
	87-A40-553-080	DIODE, 1N4003 LES		C0203	87-010-182-080		C-CAP, S 2200P-50 K B C2012
	87-A40-776-080	ZENER, UZ27BSD		C0204	87-010-182-080		C-CAP, S 2200P-50 K B C2012
	87-A40-764-080	ZENER, UZ10BSC		C0205	87-012-140-080		C-CAP, S 470P-50 J CH
	87-A40-270-080	C-DIODE, MC2838		C0206	87-012-140-080		C-CAP, S 470P-50 J CH
	87-A40-313-080	C-DIODE, MC2840		C0209	87-010-402-080		CAP, E 2.2-50 M 11L SME
	87-A40-269-080	C-DIODE, MC2836		C0210	87-010-402-080		CAP, E 2.2-50 M 11L SME
	87-A40-768-080	ZENER, UZ16BSA		C0211	87-010-184-080		C-CAP, S 3300P-50 K B C2012
	87-020-465-080	DIODE, 1SS133<K>		C0212	87-010-184-080		C-CAP, S 3300P-50 K B C2012
	87-A40-752-080	ZENER, UZ6.2BSC		C0213	87-010-402-080		CAP, E 2.2-50 M 11L SME
	87-A40-802-080	ZENER, UZ5.1BSC		C0214	87-010-402-080		CAP, E 2.2-50 M 11L SME
	87-A40-739-080	ZENER, UZ2.7BSA		C0217	87-010-405-080		CAP, E 10-50 M 11L SME
	87-017-149-080	ZENER, HZS6A2L		C0218	87-010-405-080		CAP, E 10-50 M 11L SME
				C0220	87-010-405-080		CAP, E 10-50 M 11L SME
				C0223	87-010-190-080		C-CAP, S 0.01-50 Z F C2012
				C0224	87-010-190-080		C-CAP, S 0.01-50 Z F C2012
				C0228	87-010-405-080		CAP, E 10-50 M 11L SME
<b>MAIN C.B</b>							

REF. NO	PART NO.	KANRI NO.	DESCRIPTION	REF. NO	PART NO.	KANRI NO.	DESCRIPTION
C0229	87-010-196-080		C-CAP,S 0.1-25 Z F C2012	C0612	87-010-545-080		CAP,E 0.22-50 M 11L SME
C0230	87-010-196-080		C-CAP,S 0.1-25 Z F C2012	C0613	87-010-545-080		CAP,E 0.22-50 M 11L SME
C0231	87-010-196-080		C-CAP,S 0.1-25 Z F C2012	C0614	87-010-545-080		CAP,E 0.22-50 M 11L SME
C0232	87-010-196-080		C-CAP,S 0.1-25 Z F C2012	C0615	87-010-154-080		C-CAP,S 10P-50 D CH GRM
C0233	87-010-190-080		C-CAP,S 0.01-50 Z<K,0EZ,2EZ>	C0616	87-010-385-080		CAP,E 220-25 M SME
C0234	87-010-190-080		C-CAP,S 0.01-50 Z<K,0EZ,2EZ>	C0617	87-010-385-080		CAP,E 220-25 M SME
C0237	87-010-322-080		C-CAP,S 100P-50 J<K,0EZ,2EZ>	C0618	87-010-405-080		CAP,E 10-50 M 11L SME
C0238	87-010-322-080		C-CAP,S 100P-50 J<K,0EZ,2EZ>	C0620	87-010-263-080		CAP,E 100-10 M 11L SME
C0239	87-010-196-080		C-CAP,S 0.1-25 Z F C2012	C0630	87-016-669-080		C-CAP,S 0.1-25 K B
C0270	87-010-197-080		C-CAP,S 0.01-25 K<K,0EZ,2EZ>	C0631	87-010-185-080		C-CAP,S 3900P-50 K B
C0301	87-010-178-080		C-CAP,S 1000P-50 K B C2012	C0632	87-010-185-080		C-CAP,S 3900P-50 K B
C0302	87-010-178-080		C-CAP,S 1000P-50 K B C2012	C0633	87-016-369-080		C-CAP,S 0.033-25 K B GRM
C0303	87-010-178-080		C-CAP,S 1000P-50 K B C2012	C0634	87-016-369-080		C-CAP,S 0.033-25 K B GRM
C0304	87-010-178-080		C-CAP,S 1000P-50 K B C2012	C0661	87-012-157-080		C-CAP,S 330P-50 J<K,0EZ,2EZ>
C0307	87-010-263-080		CAP,E 100-10 M 11L SME	C0661	87-010-178-080		C-CAP,S 1000P-50 K <HA>
C0308	87-010-263-080		CAP,E 100-10 M 11L SME	C0662	87-012-157-080		C-CAP,S 330P-50 J<K,0EZ,2EZ>
C0309	87-010-318-080		C-CAP,S 47P-50 J CH GRM	C0662	87-010-178-080		C-CAP,S 1000P-50 K <HA>
C0310	87-010-318-080		C-CAP,S 47P-50 J CH GRM	C0669	87-010-180-080		C-CAP,S 1500P-50 <K,0EZ,2EZ>
C0313	87-010-188-080		C-CAP,S 6800P-50 K B C2012	C0670	87-010-180-080		C-CAP,S 1500P-50 <K,0EZ,2EZ>
C0314	87-010-188-080		C-CAP,S 6800P-50 K B C2012	C0671	87-010-196-080		C-CAP,S 0.1-25 Z F C2012<HA>
C0315	87-010-263-080		CAP,E 100-10 M 11L SME	C0672	87-010-196-080		C-CAP,S 0.1-25 Z F C2012<HA>
C0317	87-010-546-080		CAP,E 0.33-50 M 11L SME	C0673	87-010-182-080		C-CAP,S 2200P-50 K <HA>
C0318	87-010-546-080		CAP,E 0.33-50 M 11L SME	C0677	87-010-197-080		C-CAP,S 0.01-25 K B C2012
C0326	87-010-198-080		C-CAP,S 0.022-25 K B C2012	C0771	87-010-263-080		CAP,E 100-10 M 11L SME
C0327	87-012-368-080		C-CAP,S 0.1-50 Z F	C0772	87-010-197-080		C-CAP,S 0.01-25 K B C2012
C0360	87-010-401-080		CAP,E 1-50 M 11L SME	C0779	87-010-186-080		C-CAP,S 4700P-50 <K,0EZ,2EZ>
C0365	87-010-197-080		C-CAP,S 0.01-25 K<K,0EZ,2EZ>	C0780	87-010-186-080		C-CAP,S 4700P-50 <K,0EZ,2EZ>
C0399	87-012-140-080		C-CAP,S 470P-50 J CH	C0782	87-010-197-080		C-CAP,S 0.01-25 K B C2012
C0401	87-010-544-080		CAP,E 0.1-50 M 11L SME	C0783	87-010-197-080		C-CAP,S 0.01-25 K B C2012
C0402	87-010-544-080		CAP,E 0.1-50 M 11L SME	C0784	87-010-197-080		C-CAP,S 0.01-25 K B C2012
C0403	87-010-321-080		C-CAP,S 82P-50 J CH	C0785	87-010-197-080		C-CAP,S 0.01-25 K B C2012
C0404	87-010-321-080		C-CAP,S 82P-50 J CH	C0786	87-010-197-080		C-CAP,S 0.01-25 K B C2012
C0405	87-010-197-080		C-CAP,S 0.01-25 K B C2012	C0788	87-010-149-080		C-CAP,S 5P-50 C CH GRM
C0406	87-010-197-080		C-CAP,S 0.01-25 K B C2012	C0789	87-A11-532-080		C-CAP,S 0.022-50 <K,0EZ,2EZ>
C0407	87-010-197-080		C-CAP,S 0.01-25 K B C2012	C0789	87-A12-052-080		C-CAP,S 0.033-25 J B<HA>
C0408	87-010-197-080		C-CAP,S 0.01-25 K B C2012	C0790	87-A11-532-080		C-CAP,S 0.022-50 <K,0EZ,2EZ>
C0409	87-010-182-080		C-CAP,S 2200P-50 K B C2012	C0790	87-A12-052-080		C-CAP,S 0.033-25 J B<HA>
C0410	87-010-182-080		C-CAP,S 2200P-50 K B C2012	C0791	87-010-196-080		C-CAP,S 0.1-25 Z F C2012
C0411	87-010-405-080		CAP,E 10-50 M 11L SME	C0792	87-010-197-080		C-CAP,S 0.1-25 K B C2012
C0412	87-010-405-080		CAP,E 10-50 M 11L SME	C0793	87-010-404-080		CAP,E 4.7-50 M 11L SME
C0452	87-010-382-080		CAP,E 22-25 M 11L SME	C0795	87-010-197-080		C-CAP,S 0.01-25 K B C2012
C0453	87-010-183-080		C-CAP,S 2700P-50 K B GRM	C0796	87-010-197-080		C-CAP,S 0.01-25 K B C2012
C0454	87-010-183-080		C-CAP,S 2700P-50 K B GRM	C0797	87-010-405-080		CAP,E 10-50 M 11L SME
C0455	87-010-183-080		C-CAP,S 2700P-50 K B GRM	C0798	87-010-197-080		C-CAP,S 0.01-25 K B C2012
C0456	87-010-197-080		C-CAP,S 0.01-25 K B C2012	C0799	87-010-407-080		CAP,E 33-50 M 11L SME
C0458	87-010-178-080		C-CAP,S 1000P-50 K B C2012	C0800	87-012-369-080		C-CAP,S 0.047-50 Z F
C0459	87-010-175-080		C-CAP,S 560P-50 J SL	C0801	87-010-403-080		CAP,E 3.3-50 M 11L SME
C0460	87-010-196-080		C-CAP,S 0.1-25 Z F C2012	C0802	87-010-194-080		C-CAP,S 0.047-25 Z F
C0461	87-012-158-080		C-CAP,S 390P-50 J CH GRM	C0803	87-010-198-080		C-CAP,S 0.022-25 K B C2012
C0462	87-012-158-080		C-CAP,S 390P-50 J CH GRM	C0804	87-010-263-080		CAP,E 100-10 M 11L SME
C0507	87-010-196-080		C-CAP,S 0.1-25 Z F C2012	C0807	87-010-400-080		CAP,E 0.47-50 M 11L SME
C0508	87-010-178-080		C-CAP,S 1000P-50 K B C2012	C0808	87-010-401-080		CAP,E 1-50 M 11L SME
C0509	87-A10-300-080		CAP,M 0.027-50 J	C0809	87-010-401-080		CAP,E 1-50 M 11L SME
C0510	87-A10-300-080		CAP,M 0.027-50 J	C0810	87-010-196-080		C-CAP,S 0.1-25 Z F C2012
C0515	87-A10-300-080		CAP,M 0.027-50 J	C0814	87-010-197-080		C-CAP,S 0.01-25 K B C2012
C0516	87-A10-300-080		CAP,M 0.027-50 J	C0815	87-010-400-080		CAP,E 0.47-50 M 11L SME
C0518	87-010-196-080		C-CAP,S 0.1-25 Z F C2012	C0816	87-010-400-080		CAP,E 0.47-50 M 11L SME
C0519	87-010-401-080		CAP,E 1-50 M 11L SME	C0818	87-010-180-080		C-CAP,S 1500P-50 <K,0EZ,2EZ>
C0520	87-010-401-080		CAP,E 1-50 M 11L SME	C0821	87-010-405-080		CAP,E 10-50 M 11L SME
C0521	87-010-546-080		CAP,E 0.33-50 M 11L SME	C0823	87-012-349-080		C-CAP,S 1000P-50 <K,0EZ,2EZ>
C0522	87-010-546-080		CAP,E 0.33-50 M 11L SME	C0823	87-010-177-080		C-CAP,S 820P-50 J C2012<HA>
C0523	87-010-545-080		CAP,E 0.22-50 M 11L SME	C0824	87-010-405-080		CAP,E 10-50 M 11L SME
C0524	87-010-545-080		CAP,E 0.22-50 M 11L SME	C0825	87-010-596-080		C-CAP,S 0.047-16 K R C2012
C0525	87-010-545-080		CAP,E 0.22-50 M 11L SME	C0831	87-010-406-080		CAP,E 22-50 M <K,0EZ,2EZ>
C0526	87-010-545-080		CAP,E 0.22-50 M 11L SME	C0842	87-010-197-080		C-CAP,S 0.01-25 K B C2012
C0605	87-010-179-080		C-CAP,S 1200P-50 K B GRM	C0844	87-010-197-080		C-CAP,S 0.01-25 K B C2012
C0606	87-010-179-080		C-CAP,S 1200P-50 K B GRM	C0850	87-010-260-080		CAP,E 47-25 M 11L SME
C0609	87-010-213-080		C-CAP,S 0.015-25 K B GRM	C0851	87-010-197-080		C-CAP,S 0.01-25 K B C2012
C0610	87-010-213-080		C-CAP,S 0.015-25 K B GRM	C0852	87-010-197-080		C-CAP,S 0.01-25 K B C2012
C0611	87-010-545-080		CAP,E 0.22-50 M 11L SME	C0853	87-010-197-080		C-CAP,S 0.01-25 K B C2012

REF. NO	PART NO.	KANRI NO.	DESCRIPTION	REF. NO	PART NO.	KANRI NO.	DESCRIPTION
C0858	87-010-196-080		C-CAP,S 0.1-25 Z F C2012	L0202	87-003-383-010		COIL,1UH K
C0859	87-010-196-080		C-CAP,S 0.1-25 Z F C2012	L0451	87-007-342-010		COIL,OSC 85KHZ BIAS
C0860	87-010-197-080		C-CAP,S 0.01-25 K B C2012	L0801	87-A50-540-010		COIL,FM DET(TOK)
C0869	87-010-197-080		C-CAP,S 0.01-25 K B <2EZ>	L0802	87-A91-551-010		FLTR,PCFJZH-450 L(TOK)
C0870	87-018-131-080		CAP,TC U 1000P-50 K B <2EZ>	L0811	87-005-847-080		COIL,2.2UH K CECS
C0871	87-012-156-080		C-CAP,S 220P-50 J CH <2EZ>	L0832	87-005-847-080		COIL,2.2UH K CECS
C0872	87-012-156-080		C-CAP,S 220P-50 J CH <2EZ>	L0861	87-005-847-080		COIL,2.2UH K CECS<2EZ>
C0873	87-012-140-080		C-CAP,S 470P-50 J CH <2EZ>	L0941	87-A50-020-010		COIL,ANT LW 252KHZ<K,0EZ,2EZ>
C0874	87-010-405-080		CAP,E 10-50 M 11L SME<2EZ>	L0942	87-A50-019-010		COIL,OSC LW 856KHZ<K,0EZ,2EZ>
C0875	87-010-196-080		C-CAP,S 0.1-25 Z F <2EZ>	L0951	8A-NF8-668-010		COIL,AM PACK 2 <K,0EZ,2EZ>
C0876	87-010-405-080		CAP,E 10-50 M 11L SME<2EZ>	L0951	8A-NF8-667-010		COIL,AM PACK 4 (TOK)<HA>
C0877	87-010-197-080		C-CAP,S 0.01-25 K B <2EZ>	R0129	87-A00-257-080		RES,M/F 0.15-1W J
C0878	87-010-316-080		C-CAP,S 33P-50 J CH <2EZ>	R0130	87-A00-257-080		RES,M/F 0.15-1W J
C0879	87-010-314-080		C-CAP,S 22P-50 J CH <2EZ>	R0143	87-A00-439-050		RES,180-1/2W J RP<K,0EZ,2EZ>
C0940	87-010-197-080		C-CAP,S 0.01-25 <K,0EZ,2EZ>	R0143	87-A00-440-050		RES,220-1/2W J RP<HA>
C0942	87-010-149-080		C-CAP,S 5P-50 C <K,0EZ,2EZ>	R0144	87-A00-439-050		RES,180-1/2W J RP<K,0EZ,2EZ>
C0947	87-010-197-080		C-CAP,S 0.01-25 <K,0EZ,2EZ>	R0144	87-A00-440-050		RES,220-1/2W J RP<HA>
C0948	87-012-140-080		C-CAP,S 470P-50 <K,0EZ,2EZ>	R0145	87-A00-439-050		RES,180-1/2W J RP<K,0EZ,2EZ>
C0952	87-010-197-080		C-CAP,S 0.01-25 <K,0EZ,2EZ>	R0145	87-A00-440-050		RES,220-1/2W J RP<HA>
C0957	87-010-311-080		C-CAP,S 12P-50 J<K,0EZ,2EZ>	R0146	87-A00-439-050		RES,180-1/2W J RP<K,0EZ,2EZ>
C0958	87-010-197-080		C-CAP,S 0.01-25 <K,0EZ,2EZ>	R0146	87-A00-440-050		RES,220-1/2W J RP<HA>
C0959	87-010-196-080		C-CAP,S 0.1-25 Z<K,0EZ,2EZ>	R0233	87-A00-258-080		RES,M/F 0.22-1W J
C0960	87-010-196-080		C-CAP,S 0.1-25 Z F C2012	R0234	87-A00-258-080		RES,M/F 0.22-1W J
C0961	87-010-152-080		C-CAP,S 8P-50 D CH GRM<HA>	R0790	87-010-197-080		C-CAP,S 0.01-25 K B C2012
C0962	87-010-401-080		CAP,E 1-50 M 11L<K,0EZ,2EZ>	R0991	87-010-322-080		C-CAP,S 100P-50 J CH GRM
C0963	87-015-785-080		C-CAP, 0.1-25 Z F C3216	R0993	87-010-322-080		C-CAP,S 100P-50 J CH GRM
C0971	87-010-381-080		CAP,E 330-16 M SME	R0995	87-010-322-080		C-CAP,S 100P-50 J CH GRM
C0972	87-010-404-080		CAP,E 4.7-50 M 11L SME	SFR0451	87-A90-432-080		SFR,30K H NVZ6TLTA
C0973	87-010-197-080		C-CAP,S 0.01-25 K B C2012	SFR0452	87-A90-432-080		SFR,30K H NVZ6TLTA
C0974	87-010-197-080		C-CAP,S 0.01-25 K B C2012	TC0942	87-011-253-080		TRIMMER,CER 30P <K,0EZ,2EZ>
C0979	87-010-322-080		C-CAP,S 100P-50 J CH GRM	X0861	87-A70-091-010		VIB,XTAL 4.332MHZ <2EZ>
C0981	87-010-260-080		CAP,E 47-25 M 11L SME	X0991	87-A70-061-010		VIB,XTAL 4.500MHZ CSA-309
C0982	87-010-196-080		C-CAP,S 0.1-25 Z F C2012				
C0983	87-010-197-080		C-CAP,S 0.01-25 K B C2012				
C0984	87-010-197-080		C-CAP,S 0.01-25 K B C2012				
C0985	87-010-322-080		C-CAP,S 100P-50 J<K,0EZ,2EZ>	C0201	87-010-322-080		C-CAP,S 100P-50 J CH GRM
C0987	87-010-197-080		C-CAP,S 0.01-25 K B C2012	C0202	87-010-322-080		C-CAP,S 100P-50 J CH GRM
C0989	87-010-197-080		C-CAP,S 0.01-25 K<K,0EZ,2EZ>	C0203	87-010-322-080		C-CAP,S 100P-50 J CH GRM
C0991	87-010-312-080		C-CAP,S 15P-50 J CH GRM	C0204	87-010-322-080		C-CAP,S 100P-50 J CH GRM
C0992	87-010-312-080		C-CAP,S 15P-50 J CH GRM	C0205	87-010-322-080		C-CAP,S 100P-50 J CH GRM
C0993	87-010-178-080		C-CAP,S 1000P-50 K B C2012	C0206	87-010-322-080		C-CAP,S 100P-50 J CH GRM
C0995	87-010-178-080		C-CAP,S 1000P-50 K B C2012	C0207	87-010-322-080		C-CAP,S 100P-50 J CH GRM
C0997	87-010-196-080		C-CAP,S 0.1-25 Z F C2012	C0208	87-010-322-080		C-CAP,S 100P-50 J CH GRM
C0998	87-010-260-080		CAP,E 47-25 M 11L SME	C0209	87-010-322-080		C-CAP,S 100P-50 J CH GRM
C0999	87-A11-132-080		CAP,TC U 0.01-50 K B	C0210	87-010-322-080		C-CAP,S 100P-50 J CH GRM
CF0831	87-008-423-010		FLTR,CF SFE10.7MS<K,0EZ,2EZ>	C0211	87-010-322-080		C-CAP,S 100P-50 J CH GRM
CF0831	87-008-261-010		FLTR,CF SFE10.7MA5<HA>	C0251	87-010-405-040		CAP,E 10-50 M 11L SME
CF0832	82-785-747-010		CF,MS2 GHY,R<K,0EZ,2EZ>	C0253	87-010-196-080		C-CAP,S 0.1-25 Z F C2012
CF0832	87-008-261-010		FLTR,CF SFE10.7MA5<HA>	C0254	87-012-369-080		C-CAP,S 0.047-50 Z F
CN0301	87-A60-620-010		CONN,3P V 2MM JMT	C0255	87-010-560-040		CAP,E 10-50 M 5L MA
CN0351	87-A60-625-010		CONN,8P V 2MM JMT	C0256	87-010-405-040		CAP,E 10-50 M 11L SME
CN0601	87-099-719-010		CONN,30P H BLK TYK-B(X)	C0259	87-010-405-040		CAP,E 10-50 M 11L SME
CN0602	87-A60-131-010		CONN,6P V	C0264	87-A11-148-080		CAP,TC U 0.1-50 Z F<K>
CNA0001	8A-NF8-654-010		CONN ASSY,11P TID-A(480)	C0273	87-010-178-080		C-CAP,S 1000P-50 K B C2012
D0101	87-A40-269-080		C-DIODE,MC2836	C0274	87-010-178-080		C-CAP,S 1000P-50 K B C2012
D0116	87-A40-270-080		C-DIODE,MC2838	C0301	87-010-182-080		C-CAP,S 2200P-50 K B C2012
D0401	87-A40-736-080		DIODE,1N4148M(SEM)	C0302	87-010-196-080		C-CAP,S 0.1-25 Z F C2012
FFC0602	88-906-251-110		FF-CABLE,6P 1.25	C0303	87-010-196-080		C-CAP,S 0.1-25 Z F C2012<K>
FFE0831	A8-6ZA-191-130		6ZA-1 FEENM<K,0EZ,2EZ>	C0312	87-010-498-040		CAP,E 10-16 M 5L SRE
FFE0831	A8-8ZA-190-030		8ZA-1 FEUNM<HA>	C0314	87-010-196-080		C-CAP,S 0.1-25 Z F C2012
J0202	87-A60-483-010		JACK,DIA6.3 BLK ST W/S KM	C0315	87-010-196-080		C-CAP,S 0.1-25 Z F C2012
J0203	87-A60-238-010		TERMINAL,SP 4P (MSC)	C0316	87-010-196-080		C-CAP,S 0.1-25 Z F C2012
J0204	87-A61-153-010		JACK,PIN 4P R/W <K,0EZ,2EZ>	C0321	87-012-393-080		C-CAP,S 0.22-16 K W5R CM/CB
J0205	87-A61-157-010		JACK,PIN 2P R/W/BL <HA>	C0322	87-010-400-040		CAP,E 0.47-50 M 11L SME
J0602	87-A60-881-010		JACK,PIN 2P MSP 242V05 PBSN	C0325	87-A10-189-040		CAP,E 220-10 M 5L
J0831	87-A60-202-010		TERMINAL,ANT 4P <HA>	C0326	87-A10-189-040		CAP,E 220-10 M 5L
J0832	87-A60-403-010		TERMINAL,ANT PAL 2P<K,0EZ,2EZ>	C0332	87-010-178-080		C-CAP,S 1000P-50 K B C2012
L0101	87-003-383-010		COIL,1UH K	C0334	87-010-312-080		C-CAP,S 15P-50 J CH GRM
L0102	87-003-383-010		COIL,1UH K	C0335	87-012-140-080		C-CAP,S 470P-50 J CH
L0201	87-003-383-010		COIL,1UH K	C0336	87-012-155-080		C-CAP,S 180P-50 J CH GRM



REF. NO	PART NO.	KANRI NO.	DESCRIPTION	REF. NO	PART NO.	KANRI NO.	DESCRIPTION
C0339	87-012-156-080		C-CAP,S 220P-50 J CH GRM	S0425	87-A91-024-180		SW,TACT KSHG611BT
C0340	87-010-197-080		C-CAP,S 0.01-25 K B C2012	S0426	87-A91-024-180		SW,TACT KSHG611BT
C0341	87-010-194-080		C-CAP,S 0.047-25 Z F	S0430	87-A91-024-180		SW,TACT KSHG611BT
C0351	87-010-382-040		CAP,E 22-25 M 11L SME	S0431	87-A91-024-180		SW,TACT KSHG611BT
C0401	87-010-197-080		C-CAP,S 0.01-25 K B C2012	S0432	87-A91-024-180		SW,TACT KSHG611BT
C0451	87-010-196-080		C-CAP,S 0.1-25 Z F C2012	S0433	87-A91-024-180		SW,TACT KSHG611BT
C0452	87-010-196-080		C-CAP,S 0.1-25 Z F C2012	S0434	87-A91-024-180		SW,TACT KSHG611BT
C0453	87-010-196-080		C-CAP,S 0.1-25 Z F C2012	S0435	87-A91-024-180		SW,TACT KSHG611BT
C0454	87-010-196-080		C-CAP,S 0.1-25 Z F C2012	SW0252	87-A91-555-010		SW,RTRY EC12E24504
C0455	87-010-196-080		C-CAP,S 0.1-25 Z F C2012	SW0253	87-A91-542-010		SW,RTRY EC12E12504
C0458	87-010-320-080		C-CAP,S 68P-50 J CH GRM<K>	VR0501	86-NFA-607-010		VR,RTRY 10K15AX1 1 V <HA>
C0459	87-010-320-080		C-CAP,S 68P-50 J CH GRM<K>				
C0502	87-010-186-080		C-CAP,S 4700P-50 K B <HA>				
C0503	87-010-112-040		CAP,E 100-16 M 11L SME<HA>	PT C.B			
C0504	87-010-405-040		CAP,E 10-50 M 11L SME<HA>				
C0505	87-010-545-040		CAP,E 0.22-50 M 11L SME<HA>	C0001	87-010-387-080		CAP,E 470-25 M SME
C0506	87-010-320-080		C-CAP,S 68P-50 J CH GRM<HA>	C0002	87-A11-148-080		CAP,TC U 0.1-50 <K,0EZ,2EZ>
C0507	87-010-544-040		CAP,E 0.1-50 M 11L SME<HA>	C0031	87-010-403-040		CAP,E 3.3-50 M 11L SME
C0508	87-010-544-040		CAP,E 0.1-50 M 11L SME<HA>	CN0001	87-A61-122-010		CONN,11P V TID-A
C0510	87-010-322-080		C-CAP,S 100P-50 J CH <HA>	△PT0001	8A-NF8-605-010		PT,ANF-8 LH<HA>
C0511	87-010-265-040		CAP,E 33-16 M 11L SME<HA>	△PT0001	8A-NF8-608-010		PT,ANF-8 EZ<K,0EZ,2EZ>
C0512	87-010-178-080		C-CAP,S 1000P-50 K B <HA>	△PT0002	8A-NF8-673-010		PT,SUB ANF-8 (H) KAMI<HA>
C0513	87-010-196-080		C-CAP,S 0.1-25 Z F <HA>	△PT0002	8A-NF8-662-010		PT,SUB ANF-8 (E) <K,0EZ,2EZ>
C0515	87-010-178-080		C-CAP,S 1000P-50 K B <HA>	△RY0001	87-A91-339-010		RELAY,AC DC12V G5PA-2<HA>
C0602	87-010-322-080		C-CAP,S 100P-50 J CH GRM	△RY0002	87-A91-418-010		RELAY,AC12V G5PA-K,0EZ,2EZ>
C0603	87-010-322-080		C-CAP,S 100P-50 J CH GRM	△S0001	87-A90-165-010		SW,SL 1-2-3 SWS2301<HA>
C0604	87-010-322-080		C-CAP,S 100P-50 J CH GRM	△T0001	87-A60-317-010		TERMINAL, 1P MSC
C0650	87-010-196-080		C-CAP,S 0.1-25 Z F C2012	△T0002	87-A60-317-010		TERMINAL, 1P MSC
C0699	87-010-196-080		C-CAP,S 0.1-25 Z F C2012	△W0001	87-A80-092-010		AC CORD ASSY,E BLK<0EZ,2EZ>
CN0101	87-099-720-010		CONN,30P BLK TYK-B(P)	△W0001	87-A80-105-010		AC CORD ASSY,AZ<HA>
CN0102	87-099-015-010		CONN,13P V BLK 6216	△W0001	87-A80-143-010		AC CORD ASSY,E BLK<K>
CN0301	87-A60-140-010		CONN,15P V FE<HA>				
CN0302	87-A60-136-010		CONN,11P V FE<K,0EZ,2EZ>	DECK C.B			
FB0301	87-008-372-080		FLTR,EMI BL01 RN1				
FB0501	87-008-372-080		FLTR,EMI BL01 RN1<HA>	CON105	87-099-753-010		CONN,11P 9604 S F<K,0EZ,2EZ>
FFC0102	88-913-301-110		FF-CABLE,13P-1.25	CON105	87-099-756-010		CONN,15P 9604 S F<HA>
FFC0302	88-911-101-110		FF-CABLE,11P 1.25<K,0EZ,2EZ>	SFR1	87-024-581-010		SFR,3.3K DIA 6H
FFC0302	88-915-101-110		FF-CABLE, 15P 1.25 100MM<HA>	SOL1	82-ZM1-618-410		SOL ASSY,27
FL0401	8A-NF8-601-010		FL,HNA-11MM30 (ANF-8)	SOL2	82-ZM1-618-410		SOL ASSY,27
J0501	87-A61-242-010		JACK,6.3 BLK MONO W/SW <HA>	SW1	87-A90-248-010		SW,MICRO ESE11SH2CXQ
L0331	87-A50-408-010		COIL,OSC 5.76MHZ	SW2	87-A90-248-010		SW,MICRO ESE11SH2CXQ
LED0311	87-A40-589-040		LED,SLR-56VCT31 RED	SW3	87-A90-248-010		SW,MICRO ESE11SH2CXQ
LED0601	87-A40-803-010		LED,SELU1E10CXM-S LF38 BLUE	SW4	87-036-110-010		SW,MICRO SPPB62
LED0602	87-A40-619-080		LED,SLR-56PT-TE7-W GRN	SW5	87-036-110-010		SW,MICRO SPPB62
LED0603	87-A40-619-080		LED,SLR-56PT-TE7-W GRN	SW6	87-036-110-010		SW,MICRO SPPB62<HA>
LED0604	87-A40-619-080		LED,SLR-56PT-TE7-W GRN	SW8	87-A90-248-010		SW,MICRO ESE11SH2CXQ<HA>
LED0606	87-A40-619-080		LED,SLR-56PT-TE7-W GRN	SW9	87-A90-248-010		SW,MICRO ESE11SH2CXQ<HA>
LED0607	87-A40-619-080		LED,SLR-56PT-TE7-W GRN	W1	82-ZM3-601-010		RBN,CORD,4P-75
LED0608	87-A40-619-080		LED,SLR-56PT-TE7-W GRN				
S0401	87-A91-024-180		SW,TACT KSHG611BT	HEAD-1 C.B			
S0402	87-A91-024-180		SW,TACT KSHG611BT				
S0403	87-A91-024-180		SW,TACT KSHG611BT	CON301	85-ZM3-602-010		PWB,FLEX A
S0404	87-A91-024-180		SW,TACT KSHG611BT		87-NF6-615-010		CONN ASSY,3P PB
S0405	87-A91-024-180		SW,TACT KSHG611BT				
S0406	87-A91-024-180		SW,TACT KSHG611BT	HEAD-2 C.B<HA>			
S0407	87-A91-024-180		SW,TACT KSHG611BT				
S0408	87-A91-024-180		SW,TACT KSHG611BT	CON351	85-ZM3-602-010		PWB,FLEX A<HA>
S0409	87-A91-024-180		SW,TACT KSHG611BT		87-NF6-616-010		CONN ASSY,8P-RPB<HA>
S0410	87-A91-024-180		SW,TACT KSHG611BT				
S0411	87-A91-024-180		SW,TACT KSHG611BT				
S0412	87-A91-024-180		SW,TACT KSHG611BT<2EZ,HA>				
S0413	87-A91-024-180		SW,TACT KSHG611BT				
S0414	87-A91-024-180		SW,TACT KSHG611BT				
S0415	87-A91-024-180		SW,TACT KSHG611BT				
S0416	87-A91-024-180		SW,TACT KSHG611BT				
S0417	87-A91-024-180		SW,TACT KSHG611BT				
S0418	87-A91-024-180		SW,TACT KSHG611BT				
S0419	87-A91-024-180		SW,TACT KSHG611BT				
S0420	87-A91-024-180		SW,TACT KSHG611BT<2EZ,HA>				
S0421	87-A91-024-180		SW,TACT KSHG611BT<2EZ>				

TYPE	MODEL NAME	SUFFIX
<0EZ>	CX-NSZ50	EZ
<K>	CX-NSZ50	K
<HA>	CX-NSZ50	HA
<2EZ>	CX-NSZ52	EZ

チップ抵抗部品コード／CHIP RESISTOR PART CODE

チップ抵抗部品コードの成り立ち

Chip Resistor Part Coding

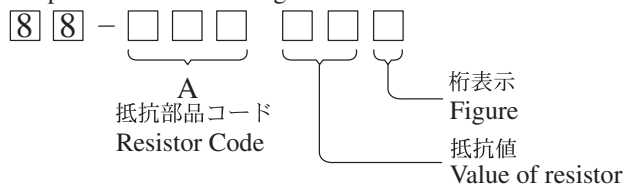

チップ抵抗  
Chip resistor

容量 Wattage	種類 Type	許容誤差 Tolerance	記号 Symbol	寸法/Dimensions (mm)			抵抗コード : A Resistor Code : A	
				外形/Form	L	W		t
1/16W	1005	± 5%	CJ		1.0	0.5	0.35	104
1/16W	1608	± 5%	CJ		1.6	0.8	0.45	108
1/10W	2125	± 5%	CJ		2	1.25	0.45	118
1/8W	3216	± 5%	CJ		3.2	1.6	0.55	128

TRANSISTOR ILLUSTRATION



E C B

2SA1981  
2SC3331  
CD1585  
CSA952  
CSC4115  
KTA1266  
KTC3198

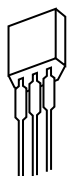

E C B

2SA933S  
DTC114ES  
KTC3199

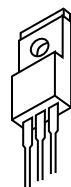

B C E

2SB1370

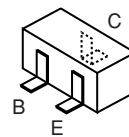

2SA1235  
2SC2714  
2SC3052  
CMBT5401  
CMBT5551  
CSD1306  
KRA107S  
KRC102S  
RT1N141C  
RT1N441C  
RT1P141C



S D G

2SJ460  
2SK2541

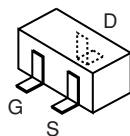

2SJ461  
2SK2158

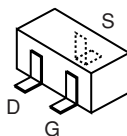

2SK360

FL (HNA-11MM30) GRID ASSIGNMENT/ANODE CONNECTION

GRID ASSIGNMENT

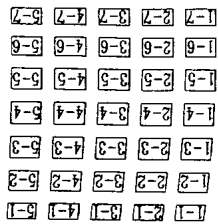
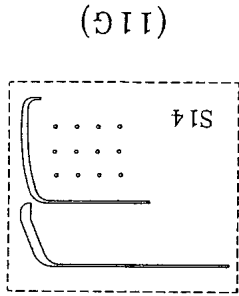

(11G)

(3G-10G)

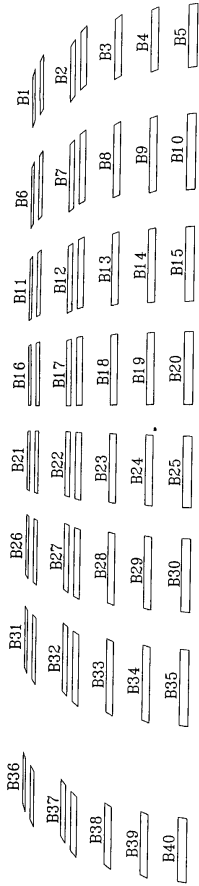

(1G)

(2G)

ANODE CONNECTION

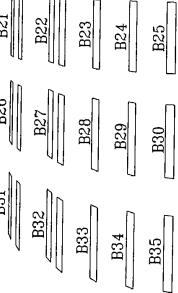
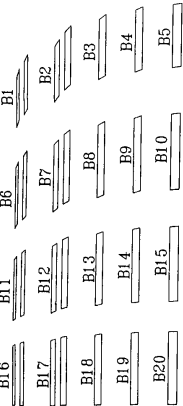

(2G)

(2G)

(11G)

(3G-10G)

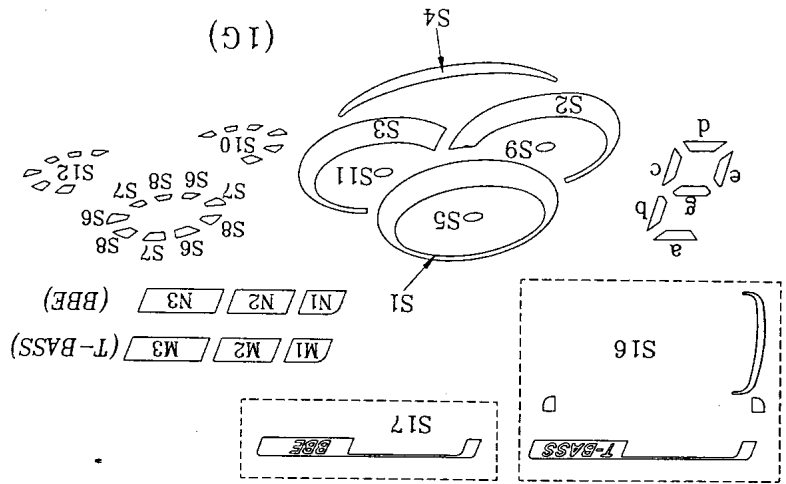

(1G)

P	1G	2G	3G-10G	11G
P1	S17	B35	1-1	G
P2	N1	B30	2-1	MONO
P3	N2	B25	3-1	RANDOM
P4	N3	B20	4-1	WOM
P5	GRAPHIC EQUALIZER	B15	5-1	EDIT
P6		B10	1-2	
P7		B5	2-2	REC
P8		B34	3-2	KHz
P9		B29	4-2	MHz
P10		B24	5-2	o
P11	S4	B19	1-3	AG
P12	S2	B14	2-3	EON
P13	S10	B9	3-3	RDS
P14	S9	B4	4-3	S14
P15	S3	B33	5-3	20
P16	S12	B28	1-4	19
P17	S11	B23	2-4	18
P18	S1	B18	3-4	17

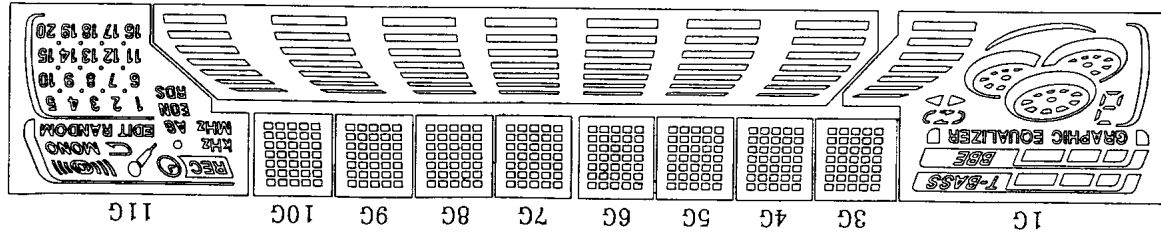

(2G)

(2G)

(2G)

(2G)

TO CD MECHANISM  
AZ0-1 ZASFRDM

FFC602  
6

# MAIN C.B.

CN602

<50/52EZ>16ZM-5 PR2NM  
TO TAPE MECHANISM <HA>12ZM-5MKZ PR4NM

TO HEAD-2 C.B.) TO REK-2)  
CN351  
<HA>  
<50/52EZ>

CN301

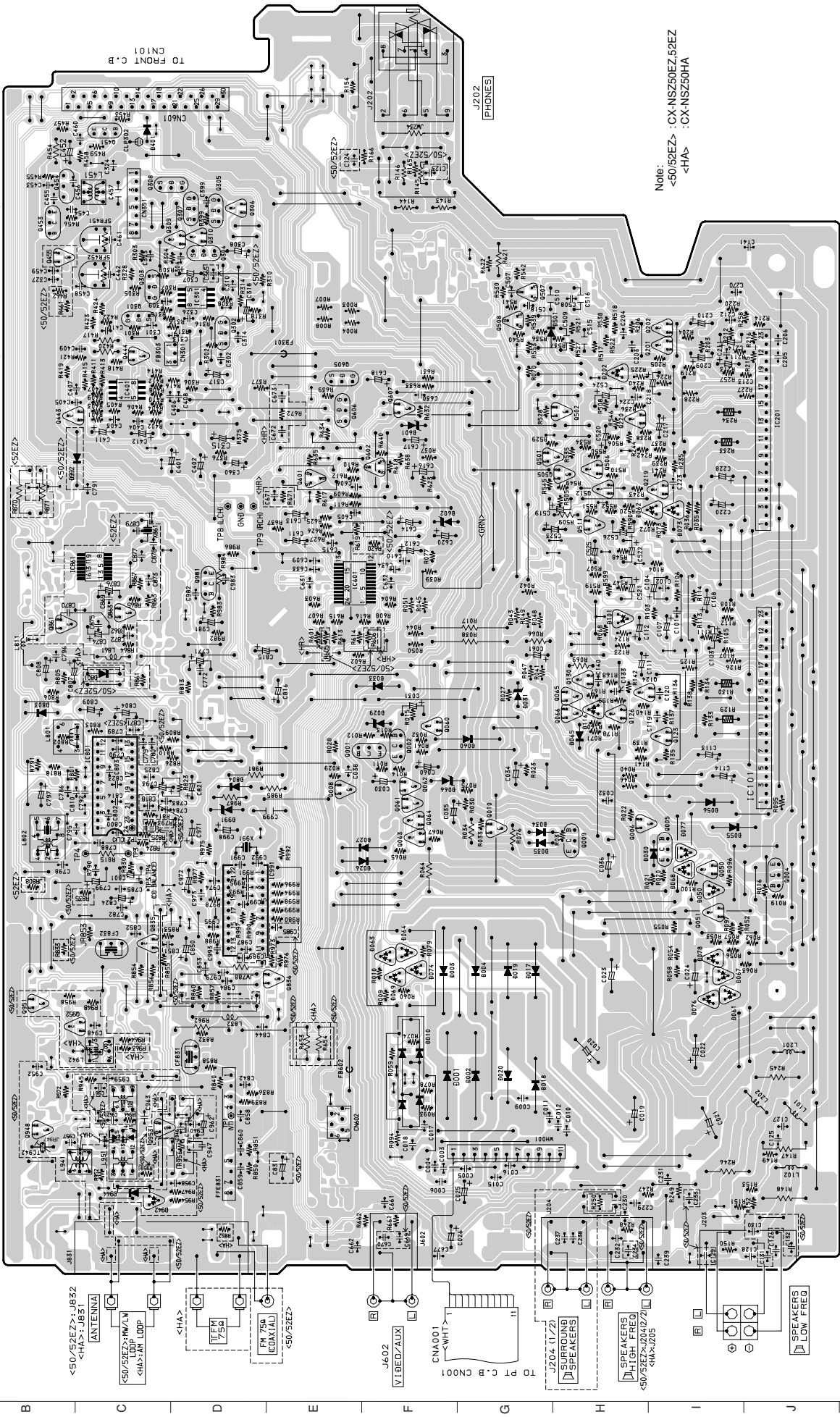

NO.6: <50/52EZ> : CX-NSZ50EZ.52EZ  
<HA> : CX-NSZ50HA

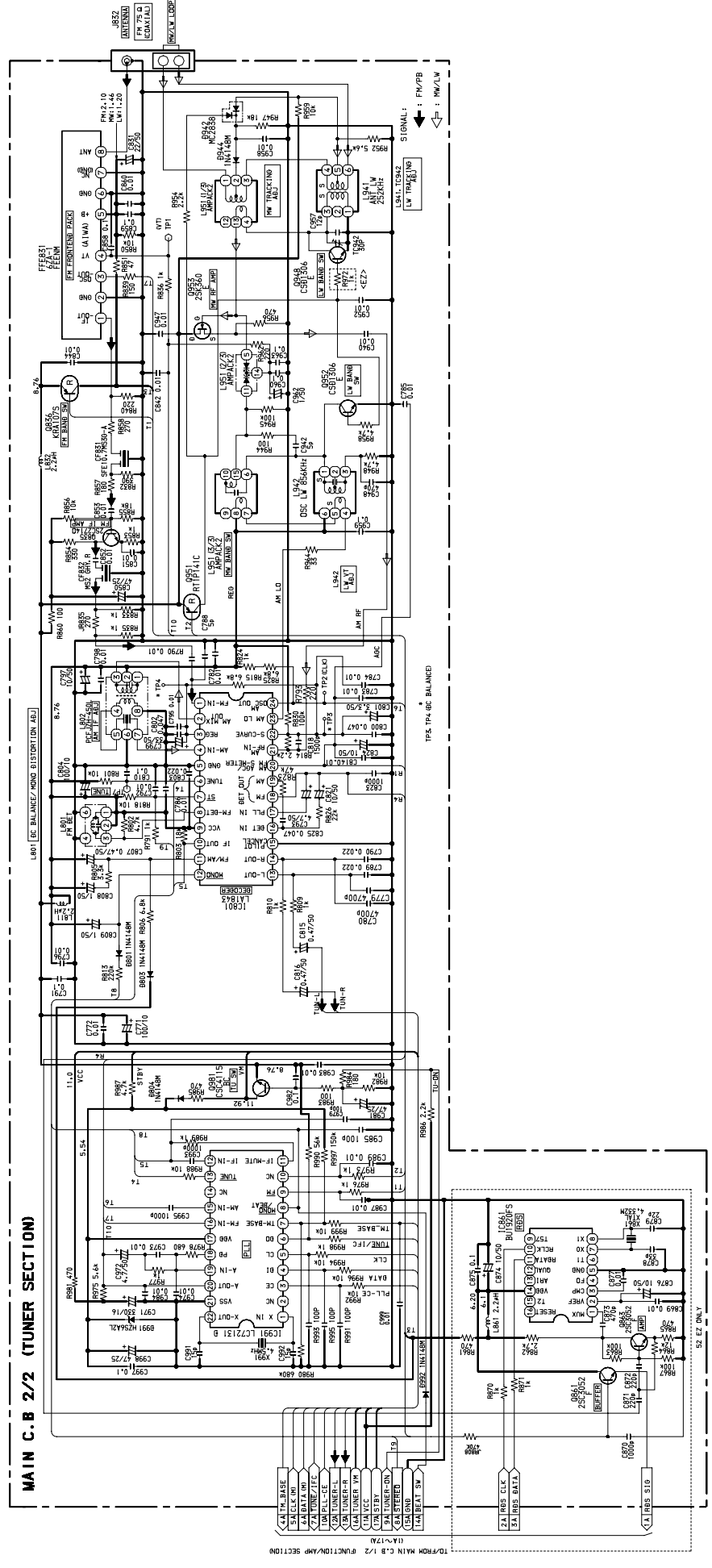

1 2 3 4 5 6 7 8 9 10 11 12 13 14

TO CD MECHANISM  
AZ0-1 YZBR00M  
FC602  
3.2 3.1 3.0 2.9 2.8 2.7 2.6 2.5 2.4 2.3 2.2 2.1 2.0 1.9 1.8 1.7 1.6 1.5 1.4 1.3 1.2 1.1 1.0 0.9 0.8 0.7 0.6 0.5 0.4 0.3 0.2 0.1  
CN602

### MAIN C.B

TO HEAD-1 C.B  
CN301  
3.2 3.1 3.0 2.9 2.8 2.7 2.6 2.5 2.4 2.3 2.2 2.1 2.0 1.9 1.8 1.7 1.6 1.5 1.4 1.3 1.2 1.1 1.0 0.9 0.8 0.7 0.6 0.5 0.4 0.3 0.2 0.1  
CN351

TO TAPE MECHANISM 6ZM-3 YPR2N  
CN351  
8.7 8.6 8.5 8.4 8.3 8.2 8.1 8.0 7.9 7.8 7.7 7.6 7.5 7.4 7.3 7.2 7.1 7.0 6.9 6.8 6.7 6.6 6.5 6.4 6.3 6.2 6.1 6.0 5.9 5.8 5.7 5.6 5.5 5.4 5.3 5.2 5.1 5.0 4.9 4.8 4.7 4.6 4.5 4.4 4.3 4.2 4.1 4.0 3.9 3.8 3.7 3.6 3.5 3.4 3.3 3.2 3.1 3.0 2.9 2.8 2.7 2.6 2.5 2.4 2.3 2.2 2.1 2.0 1.9 1.8 1.7 1.6 1.5 1.4 1.3 1.2 1.1 1.0 0.9 0.8 0.7 0.6 0.5 0.4 0.3 0.2 0.1  
CN351

TO FRONT C.B CN101  
CN101  
1 2 3 4 5 6 7 8 9 10 11 12 13 14 15 16 17 18 19 20 21 22 23 24 25 26 27 28 29 30

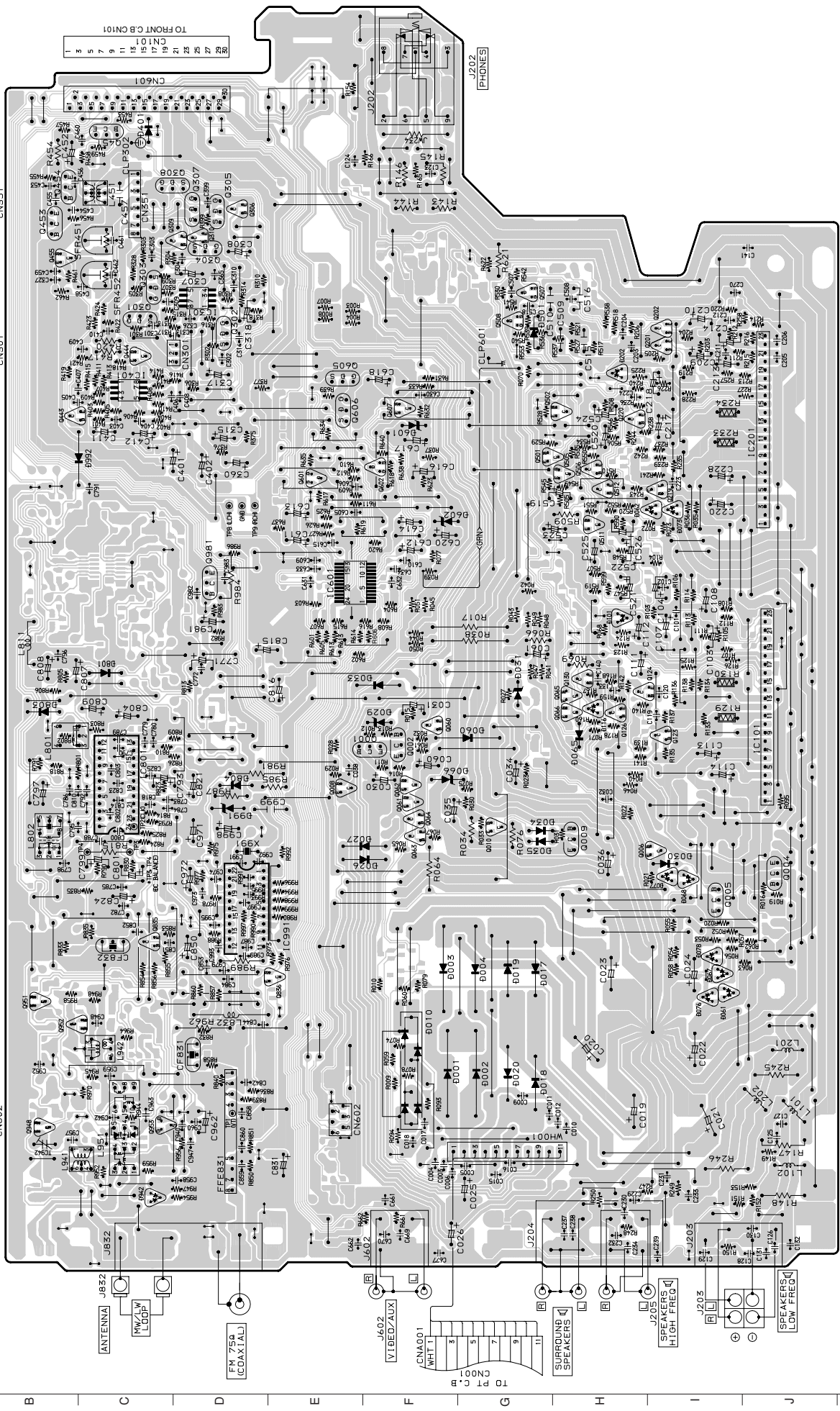

SCHEMATIC DIAGRAM-2 [TUNER SECTION] <50HA>

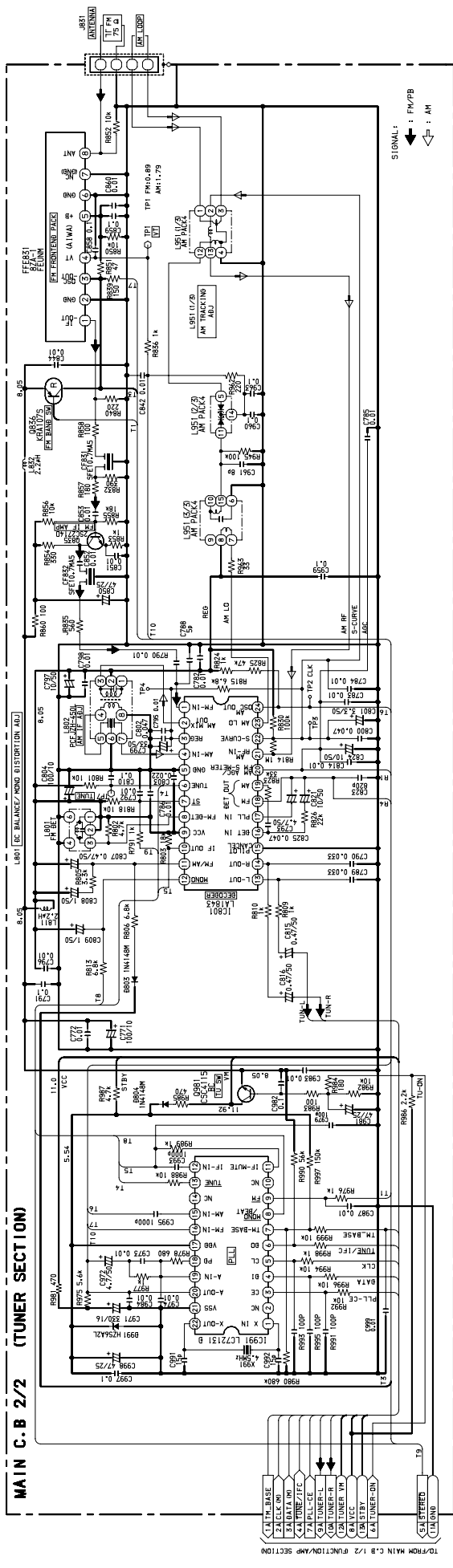

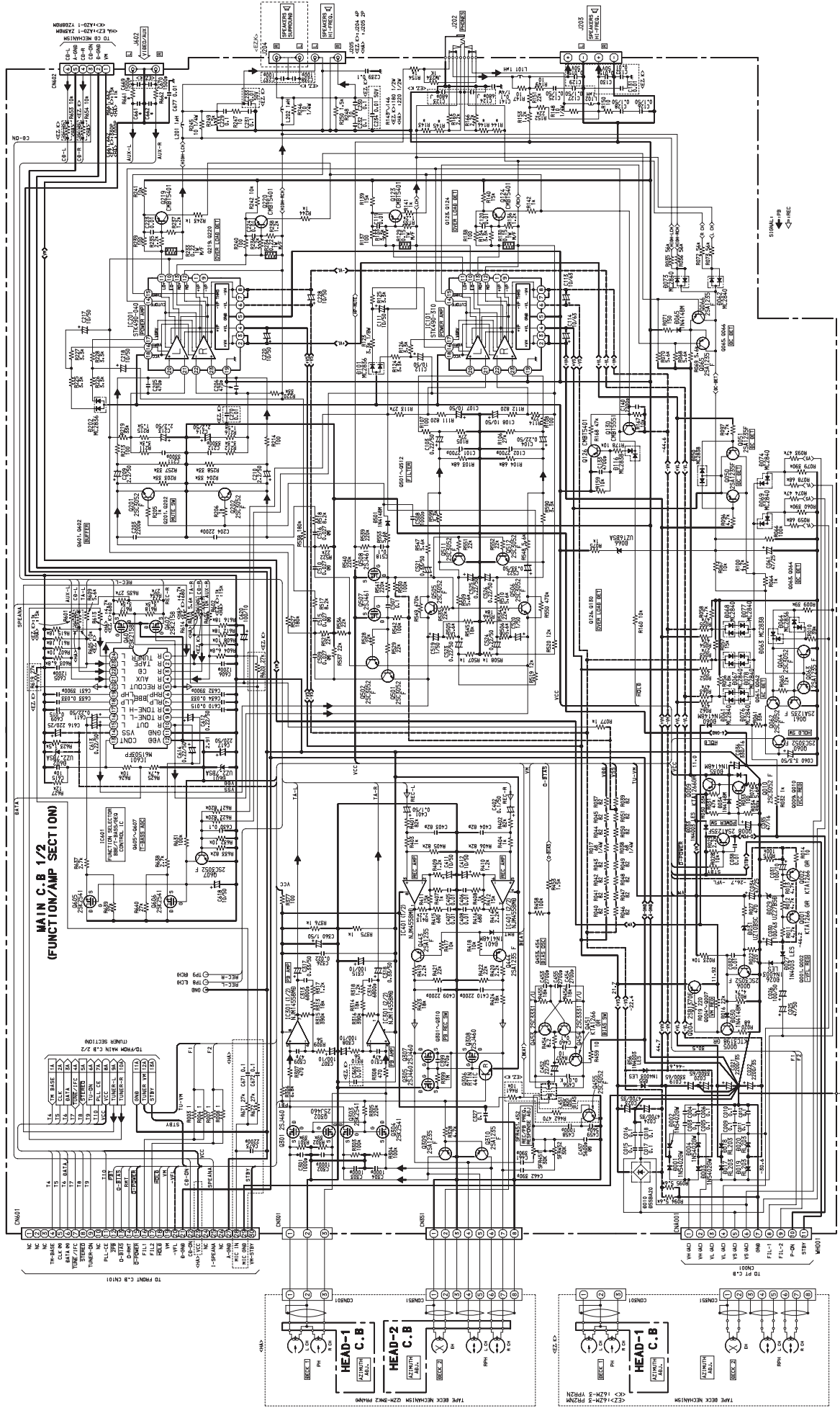



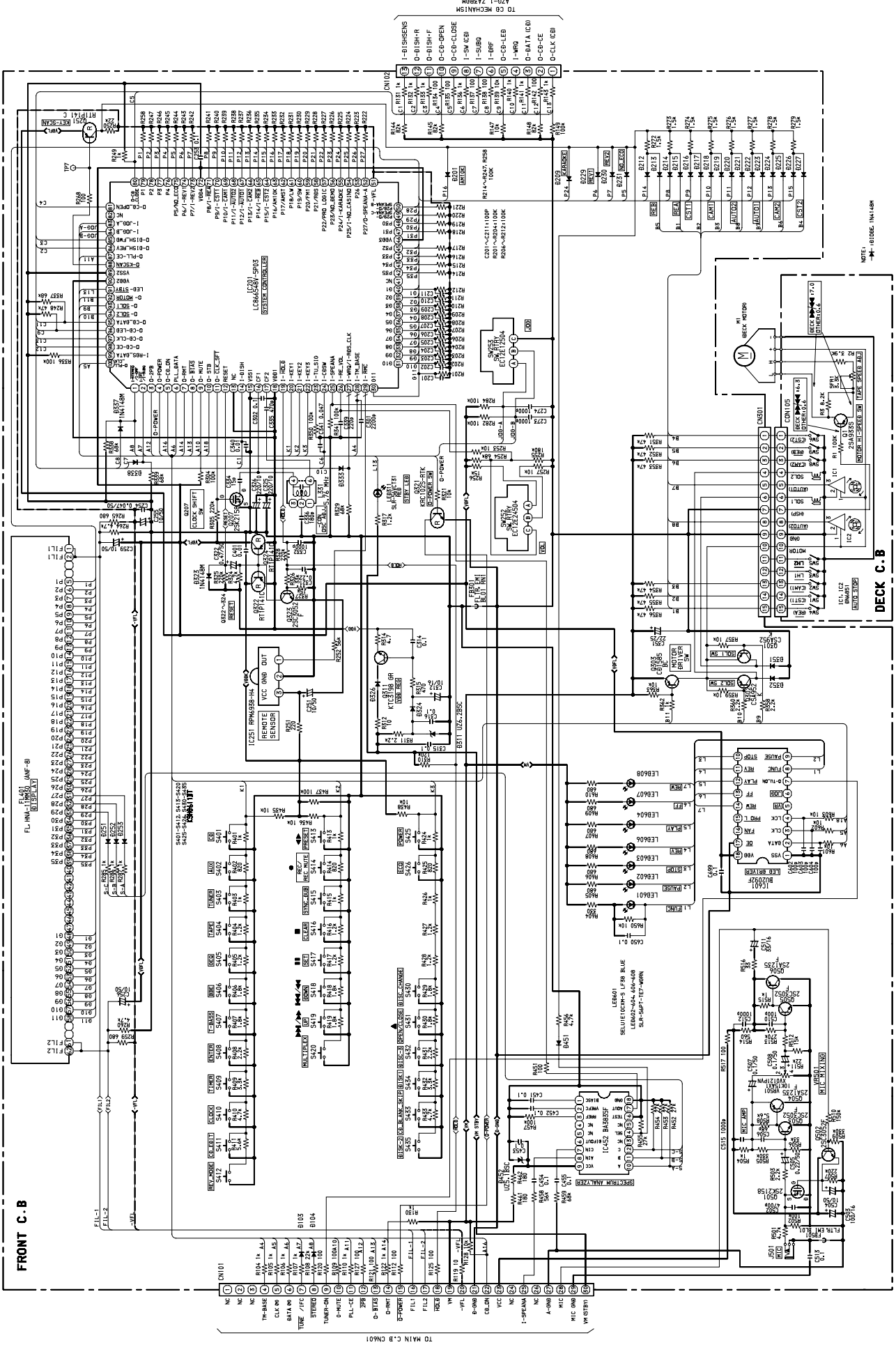

SCHEMATIC DIAGRAM-5 [FRONT SECTION] <50EZ/52EZ>

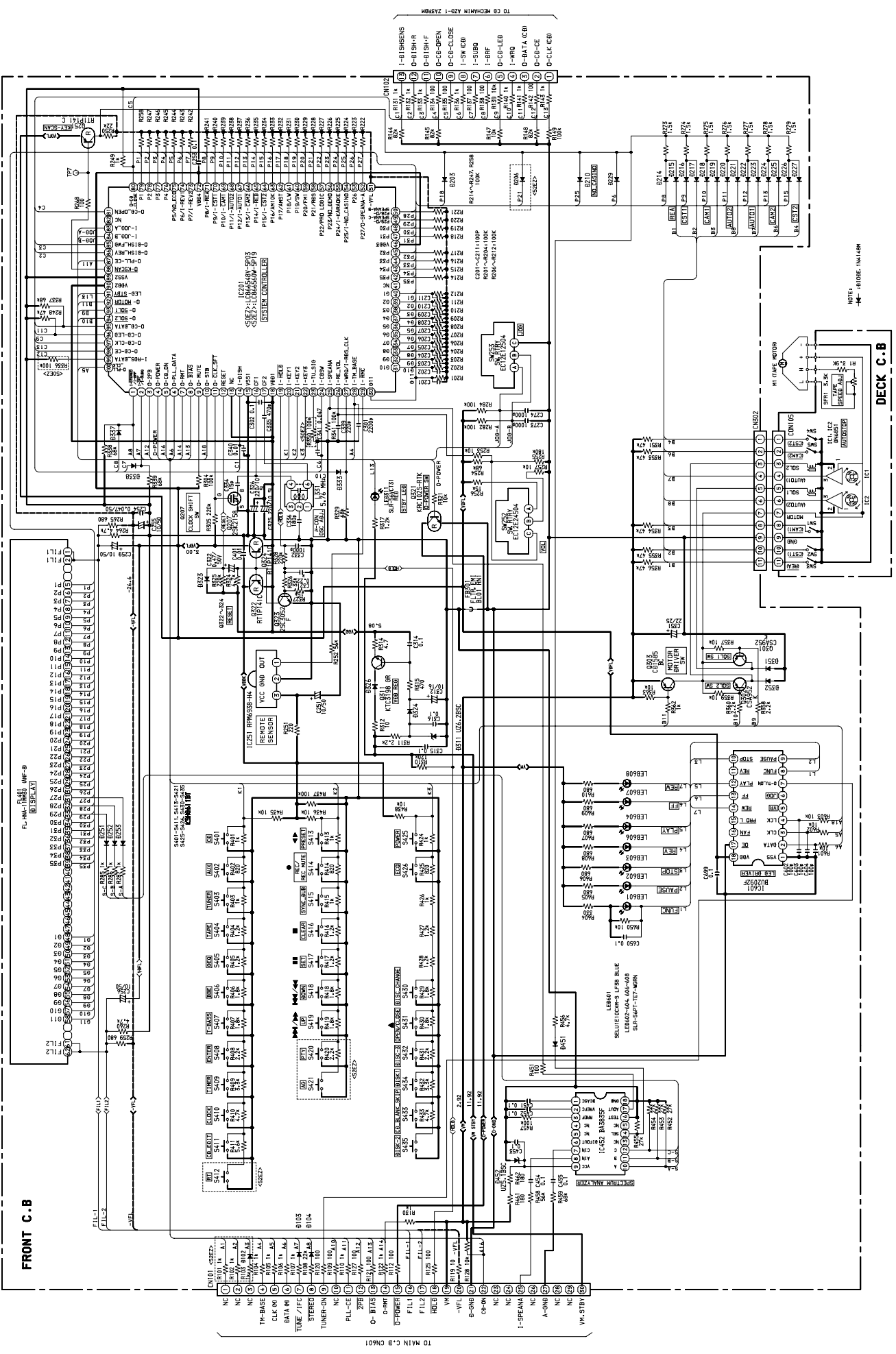

FRONT C.B

FRONT C.B

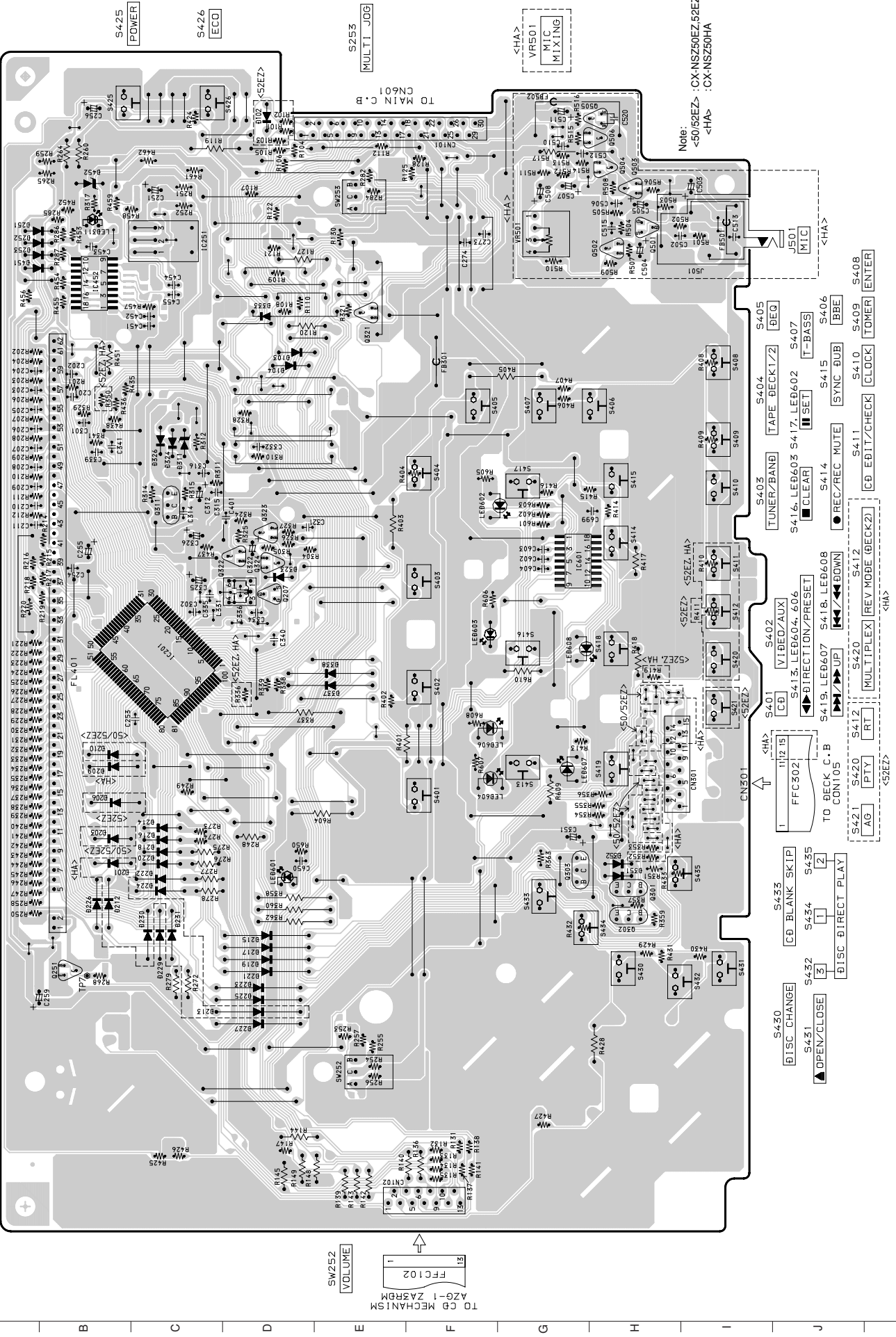

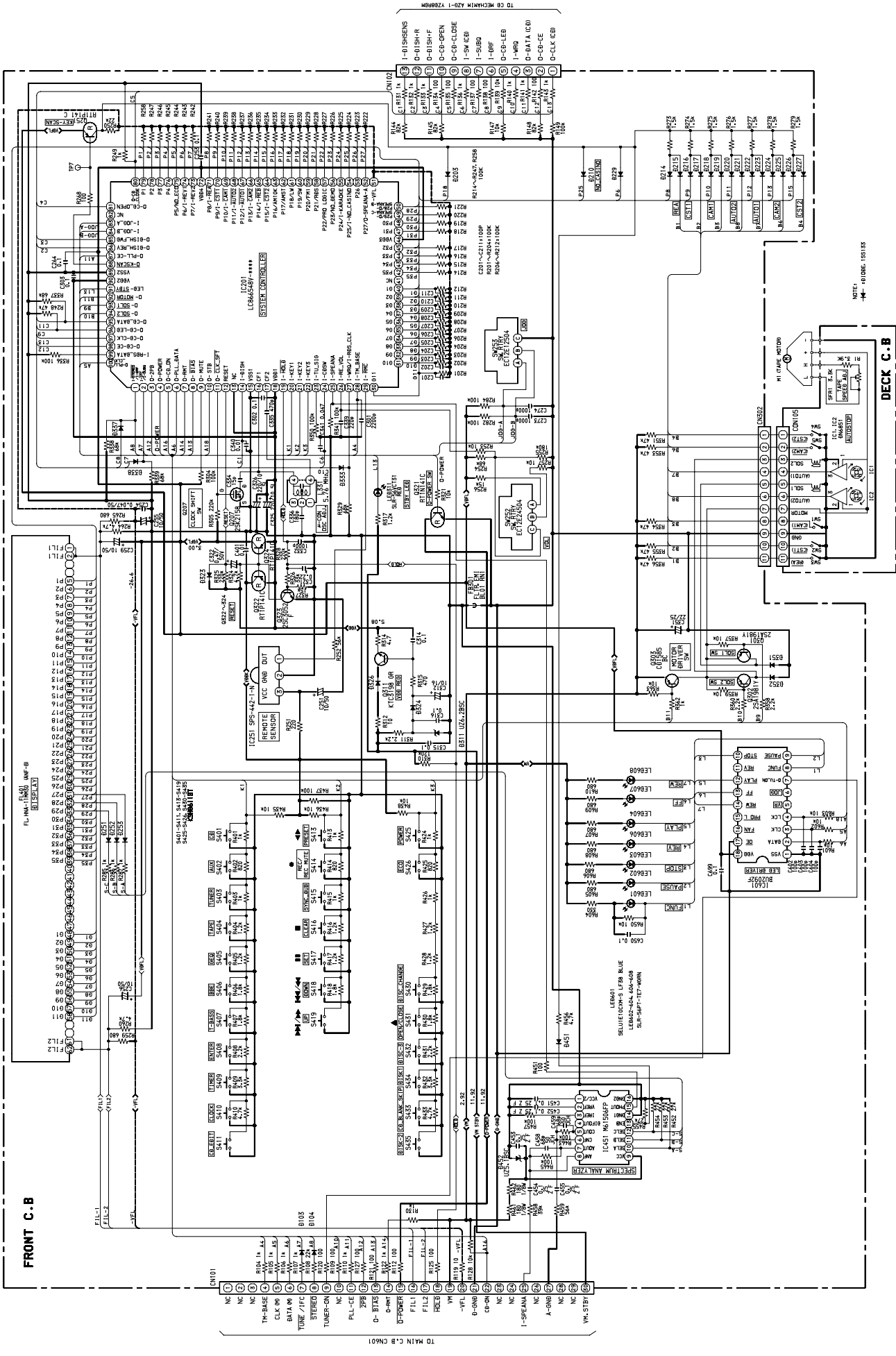

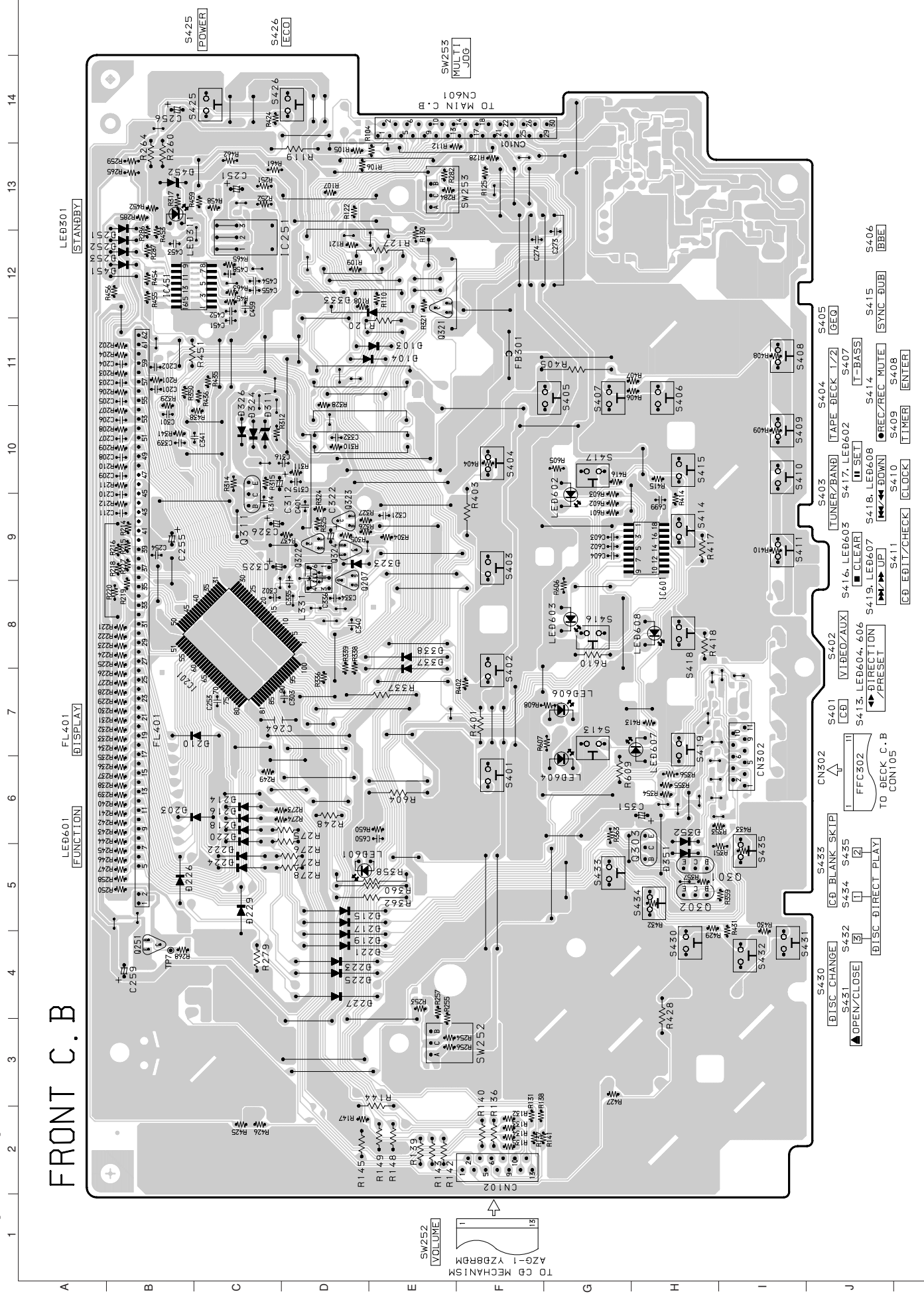

# FRONT C.B.

- SW252 [VOLUME]
- SW253 [MULTI JOG]
- SW254 [FUNCTION]
- SW255 [STANDBY]
- SW256 [CD BLANK SKIP]
- SW257 [OPEN/CLOSE]
- SW258 [DISC DIRECT PLAY]
- SW259 [DISC CHANGE]
- SW260 [CD]
- SW261 [VIDEO/AUX]
- SW262 [TUNER/BAND]
- SW263 [TAPE DECK IZ]
- SW264 [GEC]
- SW265 [T-BASS]
- SW266 [T-SET]
- SW267 [REC/REC MUTE]
- SW268 [SYNC SUB]
- SW269 [BBE]
- SW270 [TIMER]
- SW271 [ENTER]
- SW272 [CD EDIT/CHECK]
- SW273 [CLOCK]
- SW274 [STOP]
- SW275 [PAUSE]
- SW276 [SKIP]
- SW277 [REPEAT]
- SW278 [EJECT]
- SW279 [POWER]
- SW280 [MULTI]

SCHEMATIC DIAGRAM-7 [PT SECTION] <50HA>

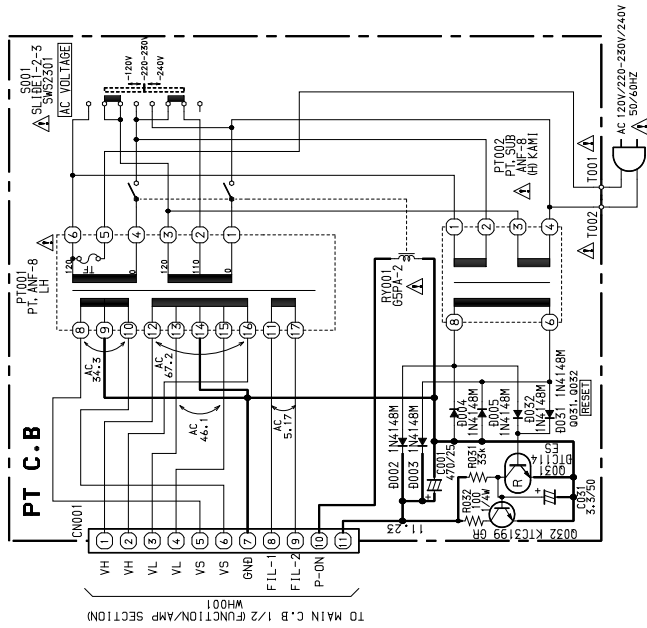

WIRING-5 [PT C.B.] <50HA>

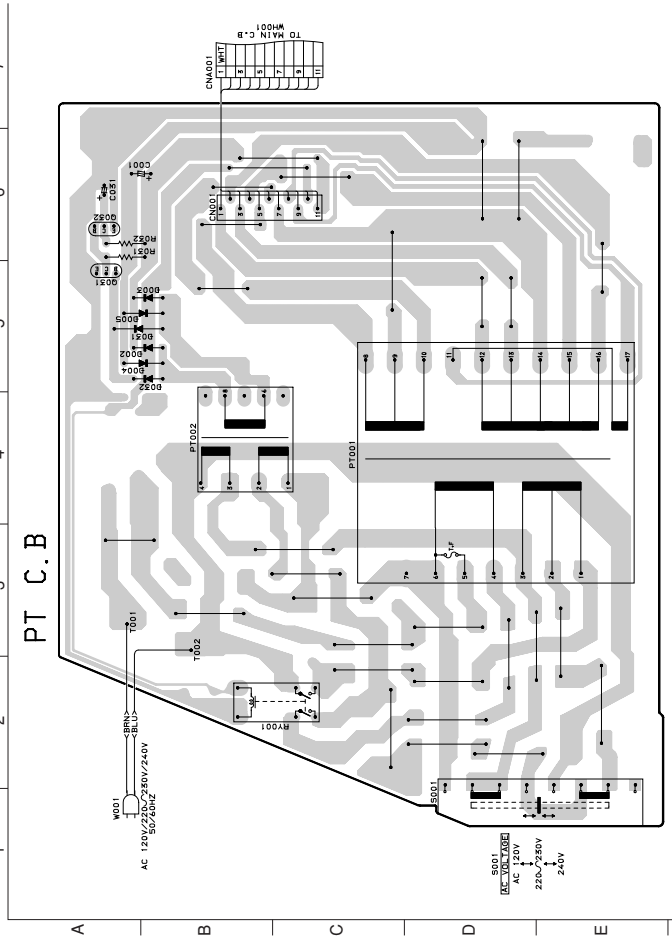

WIRING-6 [DECK C.B.] <50HA>

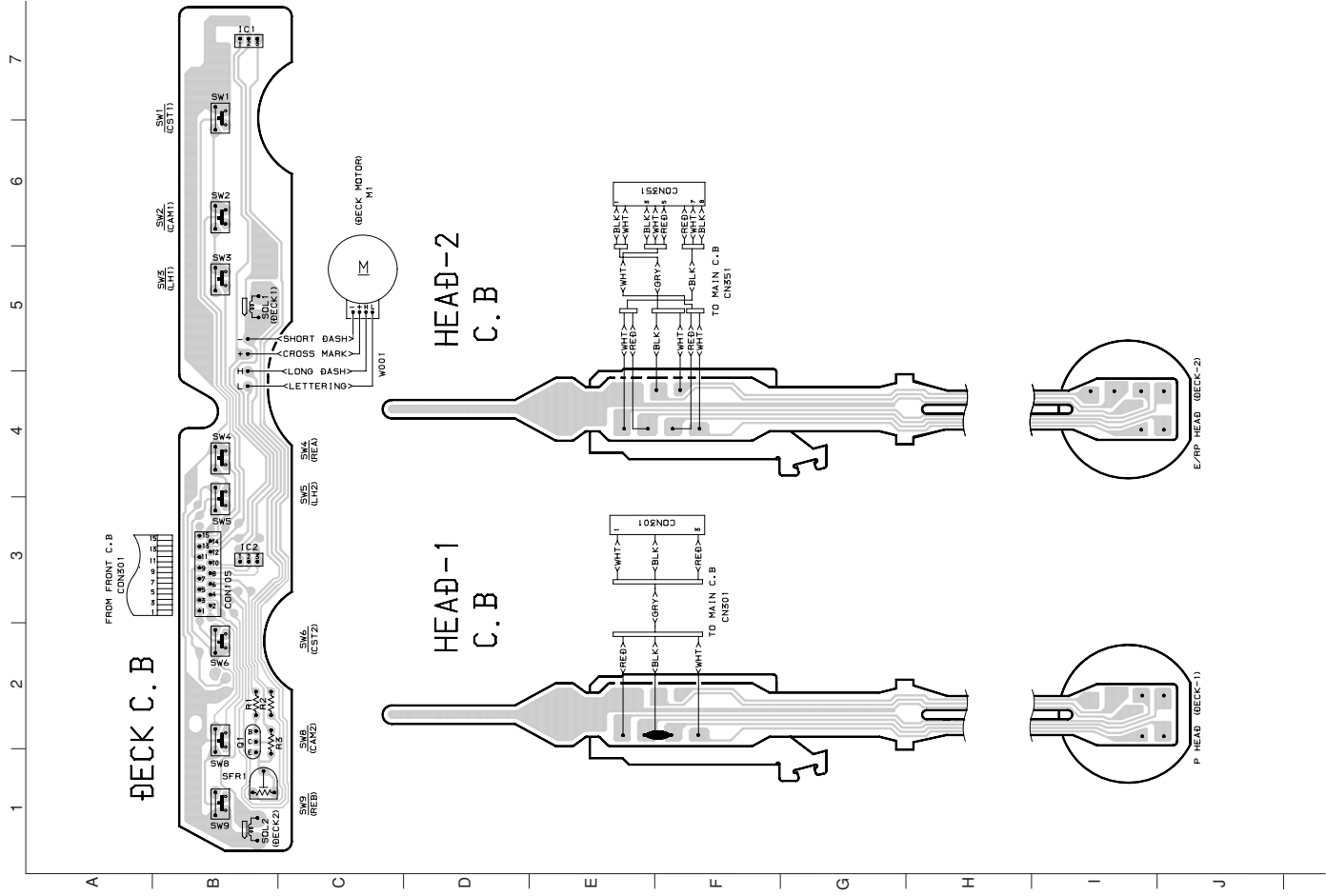

SCHEMATIC DIAGRAM-8 [PT SECTION] <50K/50EZ/52EZ>

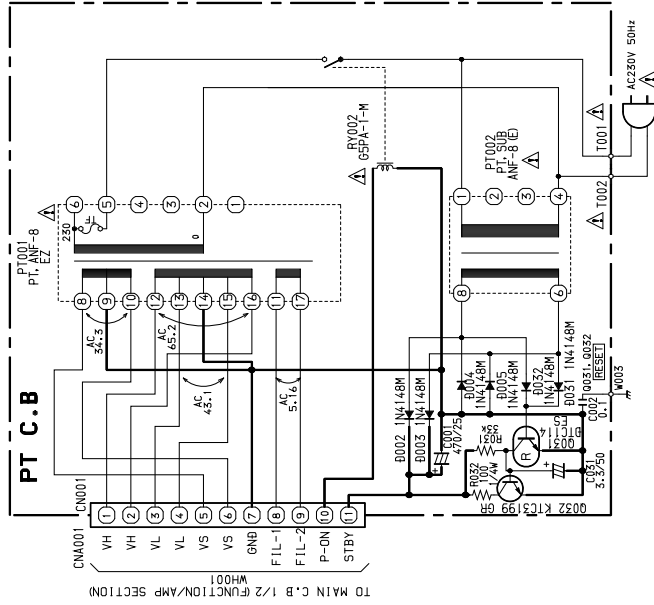

WIRING-7 [PT C.B.] <50K/50EZ/52EZ>

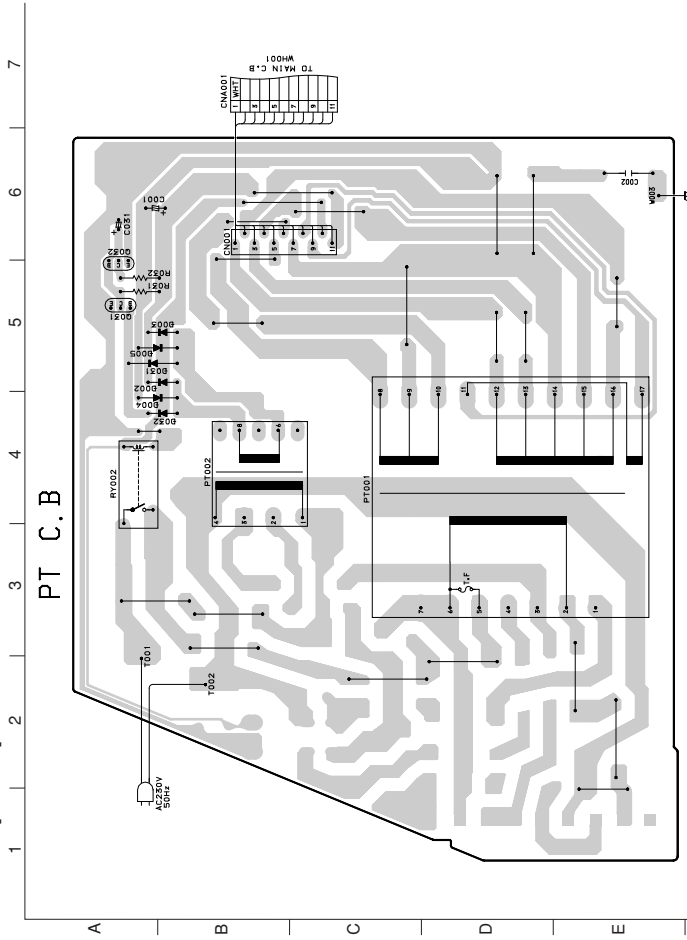

WIRING-8 [DECK C.B.] <50K/50EZ/52EZ>

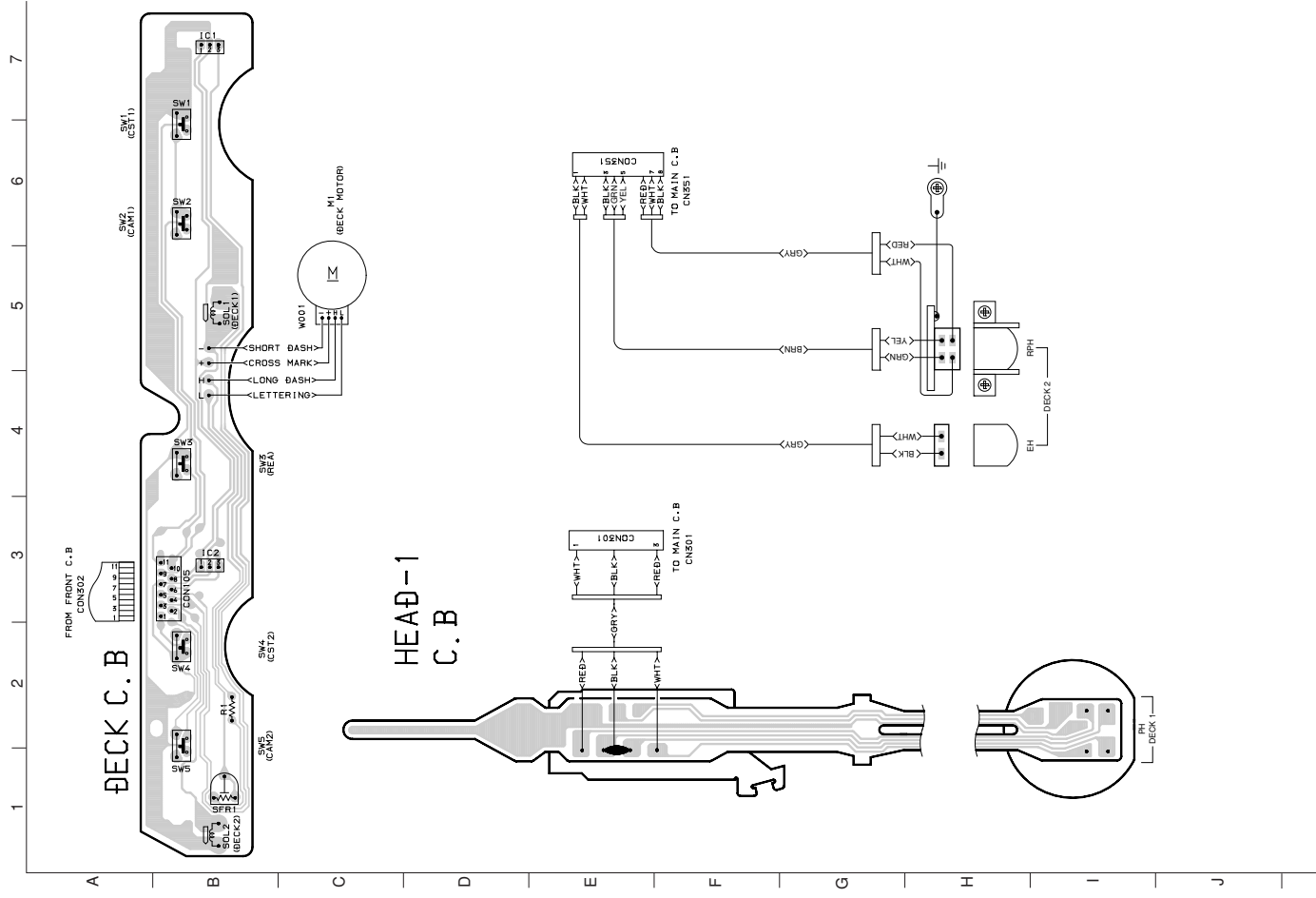

IC BLOCK DIAGRAM

IC, LA1843

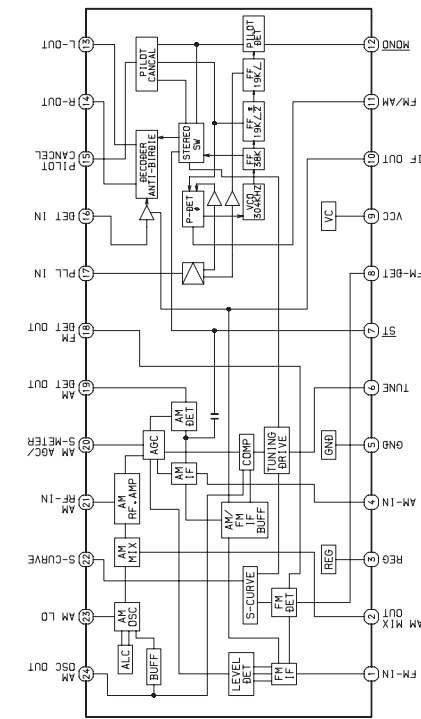

IC, LC72131D

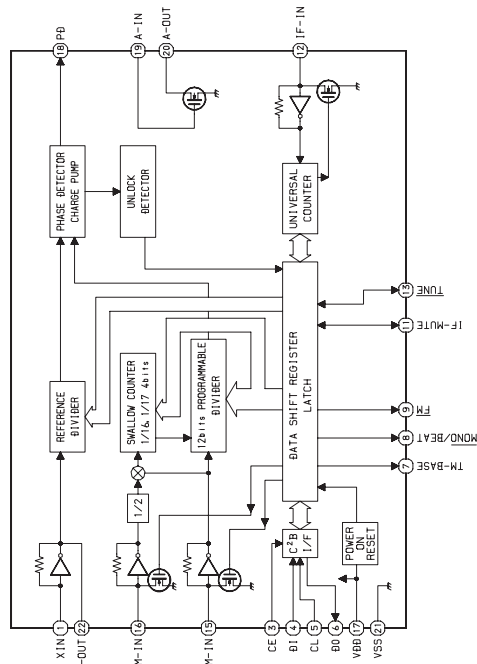

IC, BA3835F

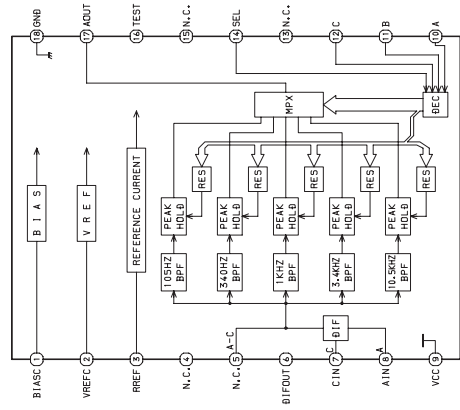

IC, BU2092F

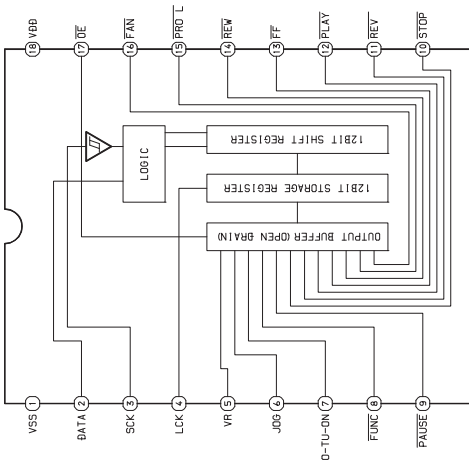

IC, M61503FP

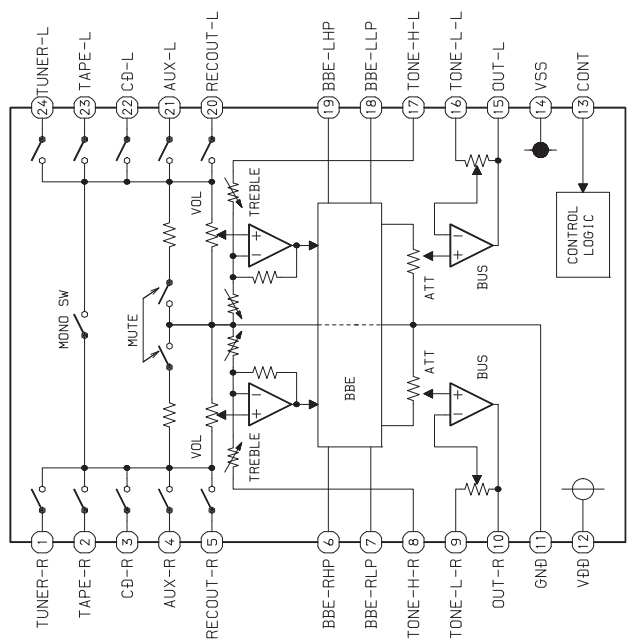



IC DESCRIPTION

IC, LC866548V-5P03 <50HA, 50EZ>, LC866548V-\*\*\*\* <50K>, LC866560W-5P19 <52EZ>

Pin No.	Pin Name	I/O	Description
1	I-STEREO/I-DRF	I	Stereo detected input/CD DRF input
2	I-IFC/I-SUBQ	I	Tune IF count serial data input/CD SUBQ input
3	O-2PB	O	Deck 2 playback switch output
4	O-POWER	O	System power supply ON/OFF output
5	O-CD-ON	O	CD power ON/OFF output
6	O-PLL_DATA	O	LED driver, Tuner IC, Function IC data output
7	O-RMT	O	Deck 2 REC MUTE output
8	O-BIAS	O	Deck 2 bias ON/OFF output
9	O-MUTE	O	System mute ON/OFF output
10	O-STB	O	Latch strobe output for LED driver IC
11	O-CLK_SFT	O	Micon clock shift output
12	RESET	I	System reset
13	NC	-	Not connected
14	I-DISH	I	CD turntable photo sensor A/D converter input
15	VSS1	-	GND
16	CF1	-	5.76 MHz oscillator circuit
17	CF2	-	5.76 MHz oscillator circuit
18	VDD1	-	Power supply input
19	I-HOLD	I	Power failure detected input
20	I-KEY1	I	KEY input (A/D)
21	I-KEY2	I	KEY input (A/D)
22	I-KEY3	I	KEY input (A/D)
23	I-TU_SIG	I	Tuner signal input
24	I-CDSW	I	CD mechanical switch A/D converter input
25	I-SPEANA	I	A/D input for spectrum analyzer display
26	I-RE_VOL	I	Rotary encoder input (VOL)
27	I-WRQ/I-RDS_CLK	I	CD WRQ input/Tuner RDS clock input
28	I-TM_BASE	I	Reference clock input for timer watch
29	I-RMC	I	System remotecontrol signal input
30 ~ 40	G11 ~ G1	O	FL GRID output G11 ~ G1
41	NC	-	Not connected
42 ~ 45	P35 ~ P32	O	FL SEGMENT output P35 ~ P32
46	VDD3	-	Power supply input
47 ~ 48	P31 ~ P30	O	FL SEGMENT output P31 ~ P30
49	P29/O-SPEANA-C	O	FL SEGMENT output P29/Spectrum analyzer band switching output
50	P28/O-SPEANA-B	O	FL SEGMENT output P28/Spectrum analyzer band switching output
51	VFL	-	Power supply input for FL display
52	P27/O-SPEANA-A	O	FL SEGMENT output P27/Spectrum analyzer band switching output
53	P26	O	FL SEGMENT output P26
54	P25/I-NO_CASINO	I/O	FL SEGMENT output P25/NO CASINO DEMO input to diode
55	P24/I-KARAOKE	I/O	FL SEGMENT output P24/KARAOKE input to diode
56	P23/NO_DEMO	I/O	FL SEGMENT output P23/NO DEMO input to diode

Pin No.	Pin Name	I/O	Description
57	P22/PRO LOGIC	I/O	FL SEGMENT output P22/PROLOGIC input to diode (not used)
58	P21/RDS	I/O	FL SEGMENT output P21/RDS input to diode
59	P20/FM1	I/O	FL SEGMENT output P20/FM1 input to diode
60	P19/SW	I/O	FL SEGMENT output P19/SW input to diode
61	P18/LW	I/O	FL SEGMENT output P18/LW input to diode
62	P17/AMST	I/O	FL SEGMENT output P17/AMST input to diode
63	P16/AM10K	I/O	FL SEGMENT output P16/AM10K input to diode
64	P15/I-CST2	I/O	FL SEGMENT output P15/DECK2 cassette detect switch data input
65	P14/I-REB	I/O	FL SEGMENT output P14/DECK2 side-B record OK switch data input
66	P13/I-CAM2	I/O	FL SEGMENT output P13/DECK2 CAM switch signal input
67	P12/I-AUTO1	I/O	FL SEGMENT output P12/DECK1 AUTO STOP signal input
68	P11/I-AUTO2	I/O	FL SEGMENT output P11/DECK2 AUTO STOP signal input
69	P10/I-CAM1	I/O	FL SEGMENT output P10/DECK1 CAM switch data input
70	P9/I-CST1	I/O	FL SEGMENT output P9/DECK1 cassette detect switch data input
71	P8/I-REA	I/O	FL SEGMENT output P8/DECK2 side A record OK switch data input
72	VDD4	-	Power supply input
73	P7/I-REV2	I/O	FL SEGMENT output P7/DECK2 REVERSE mode input to diode
74	P6/I-REV1	I/O	FL SEGMENT output P6/DECK1 REVERSE mode input to diode
75	P5/NO_ECO	I/O	FL SEGMENT output P5/NO ECO MODE input to diode
76 ~ 79	P4 ~ P1	O	FL SEGMENT output P4 ~ P1
80	O-CD-CLOSE	O	CD TRAY CLOSE data output
81	O-CD-OPEN	O	CD TRAY OPEN data output
82	NC	-	Not connected
83	I-JOG_A	I	Rotary encoder A input (JOG)
84	I-JOG_B	I	Rotary encoder B input (JOG)
85	O-DISH_FWD	O	CD turntable forward rotation output
86	O-DISH_REV	O	CD turntable reverse rotation output
87	O-PLL_CE	O	PLL IC chip enable output
88	O-KSCAN	O	Switch SCAN timing output
89	VSS2	-	GND
90	VDD2	-	Power supply input
91	LED-STBY	O	STAND BY LED (Echo mode) output
92	O-MOTOR	O	DECK MOTOR ON/OFF output
93	O-SOL1	O	DECK1 solenoid output
94	O-SOL2	O	DECK2 solenoid output
95	O-CD-DATA	O	CD DATA output
96	O-CD-LED	O	CD LED output
97	O-CD-CLK	O	CD clock output
98	O-CD-CE	O	CD chip enable output
99	I-RDS_DATA	I	RDS data input
100	O-PLL_CLK	O	PLL IC CLOCK output

# ADJUSTMENT <50HA>

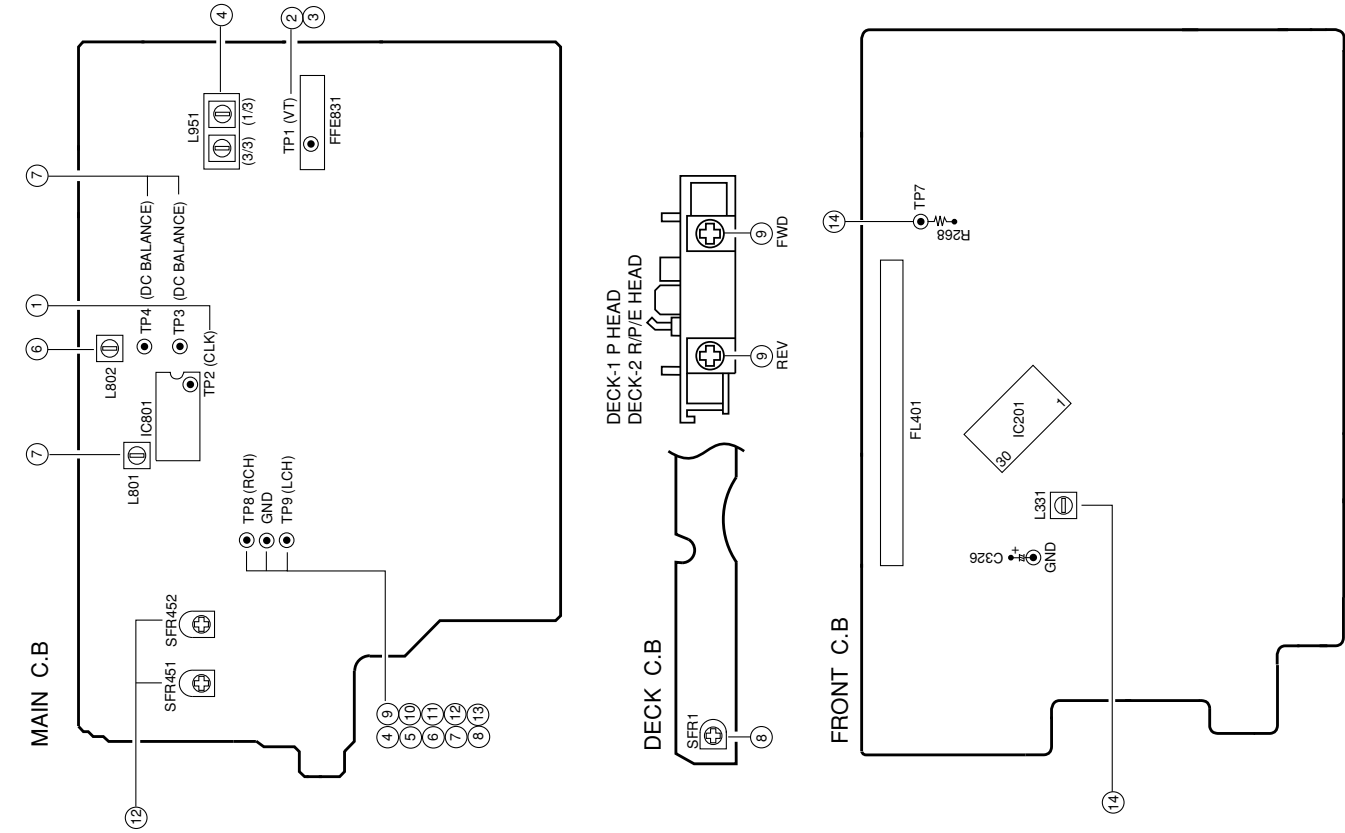

- < TUNER SECTION >
1. Clock frequency Check  
Settings : • Test point : TP2  
Method : Set to AM 1710kHz and check that the test point is 2160kHz  $\pm$  45Hz.
  2. AM VT Check  
Settings : • Test point : TP1 (VT)  
Method : Set to AM 1710kHz, 530kHz and check that the test point is less than 8.5V (1710kHz) and more than 0.6V (530kHz).
  3. FM VT Check  
Settings : • Test point : TP1 (VT)  
Method : Set to FM 87.5MHz, 108.0MHz and check that the test point is more than 0.5V (87.5MHz) and less than 8.0V (108.0MHz).
  4. AM Tracking Adjustment  
Settings : • Test point : TP8(Lch), TP9(Rch)  
• Adjustment location : L951 (1/3) ..... 1000kHz  
Method : Set to AM 1000kHz and adjust L951 (1/3) so that the level at the test point becomes maximum.
  5. FM Tracking Check  
Settings : • Test point : TP8(Lch), TP9(Rch)  
Method : Set to FM 98.0MHz and check that the test point is less than 90 $\mu$ V.
  6. AM(MW) IF Adjustment  
Settings : • Test point : TP5(Lch), TP6(Rch)  
• Adjustment location : L802 ..... 1000kHz
  7. DC Balance / Mono Distortion Adjustment  
Settings : • Test point : TP3, TP4 (DC Balance)  
• Adjustment location : L801  
• Input level : 60dB $\mu$ V  
Method : Set to FM 98.0MHz and adjust L801 so that the voltage between TP3 and TP4 becomes 0V  $\pm$  0.3V.  
Next, check that the distortion is less than 1.3%.
- < DECK SECTION >
8. Tape Speed Adjustment (DECK 2)  
Settings : • Test tape : TTA-100  
• Test point : TP8(Lch), TP9(Rch)  
• Adjustment location : SFR1  
Method : Play back the test tape and adjust SFR1 so that the frequency counter reads 3000Hz  $\pm$  5Hz and  $\pm$ 45Hz (REV) with respect to forward speed.
  9. Head Azimuth Adjustment (DECK 1, DECK 2)  
Settings : • Test tape : TTA-330  
• Test point : TP8(Lch), TP9(Rch)  
• Adjustment location : Head azimuth adjustment screw  
Method : Play back (FWD) the 8kHz signal of the test tape and adjust screw so that the output becomes maximum. Next, perform on REV PLAY mode.
10. PB Frequency Response Check (DECK 1, DECK 2)  
Settings : • Test tape : TTA-300  
• Test point : TP8(Lch), TP9(Rch)  
Method : Play back the 315Hz and 8kHz signals of the test tape and check that the output ratio of the 8kHz signal with respect to that of the 315Hz signal is within 5dB.
11. PB Sensitivity Check (DECK 1, DECK 2)  
Settings : • Test tape : TTA-200  
• Test point : TP8(Lch), TP9(Rch)  
Method : Play back the test tape and check that the output level of the test point is 140mV  $\pm$  3dB.
12. REC/PB Frequency Response Adjustment (DECK 2)  
Settings : • Test tape : TTA-602  
• Input signal : 1kHz / 8kHz (LINE IN)  
• Adjustment location : SFR451 (Lch) SFR452 (Rch)  
Method : Apply a 1kHz signal and REC mode. Then adjust OSC attenuator so that the output level at the TP8, TP9 becomes -20VU. Record and play back the 1kHz and 8kHz signals and adjust SFRs so that the output of the 8kHz signals becomes 0dB  $\pm$  0.5dB with respect to that of the 1kHz signal.
13. REC/PB Sensitivity Check (DECK 2)  
Settings : • Test tape : TTA-602  
• Test point : TP8(Lch), TP9(Rch)  
• Input signal : 1kHz (LINE IN)  
Method : Apply a 1kHz signal and REC mode. Then adjust OSC attenuator so that the output level at TP8, TP9 becomes 0VU. Record and play back the 1kHz signals and check that the output is -2dB  $\pm$  3.0dB.
- < FRONT SECTION >
14.  $\mu$ -CON OSC Adjustment  
Settings : • Test point : TP7 and GND  
• Adjustment location : L331  
Method : Insert AC plug while pressing POWER and TUNER function keys. Adjust L331 so that the frequency at the test point is 153.84kHz  $\pm$  0.15Hz.

ADJUSTMENT <50K/50EZ/52EZ>

< TUNER SECTION >  
 1. Clock frequency Check  
 Settings : • Test point : TP2  
 Method : Set to AM 1602kHz and check that the test point is 2052kHz  $\pm$  45Hz.

2. MW VT Check  
 Settings : • Test point : TP1 (VT)  
 Method : Set to MW 1602kHz, 531kHz and check that the test point is less than 8.0V (1602kHz) and more than 0.6V (531kHz).

3. LW VT Adjustment  
 Settings : • Test point : TP1 (VT)  
 • Adjustment location : L942  
 Method : Set to LW 144kHz and adjust L942 so that the test point is 1.3V  $\pm$  0.05V.  
 Then set to LW 290kHz and check that the test point is more than 0.6V.

4. FM VT Check  
 Settings : • Test point : TP1 (VT)  
 Method : Set to FM 87.5MHz, 108.0MHz and check that the test point is more than 0.5V (87.5MHz) and less than 8.0V (108.0MHz).

5. MW Tracking Adjustment  
 Settings : • Test point : TP8(Lch), TP9(Rch)  
 • Adjustment location : L951(I/F)  
 Method : Set to MW 999kHz and adjust L951(I/F) so that the level at the test point becomes maximum.

6. LW Tracking Adjustment  
 Settings : • Test point : TP8(Lch), TP9(Rch)  
 • Adjustment location : L941, TC943  
 Method : Set to TC943 to center position.  
 Set to LW 144kHz and adjust L941 so that the level at test point becomes maximum.  
 Then set to LW 290kHz and adjust TC943 so that the level at test point becomes maximum.

7. FM Tracking Check  
 Settings : • Test point : TP8(Lch), TP9(Rch)  
 Method : Set to FM 98.0MHz and check that the test point is less than 13dB $\mu$ V.

8. AM IF Adjustment  
 Settings : • Test point : TP5(Lch), TP6(Rch)  
 • Adjustment location : L802 ..... 999kHz

9. DC Balance / Mono Distortion Adjustment  
 Settings : • Test point : TP3, TP4 (DC Balance)  
 • Adjustment location : L801  
 • Input level : 60dB $\mu$ V  
 Method : Set to FM 98.0MHz and adjust L801 so that the voltage between TP3 and TP4 becomes 0V  $\pm$  0.3V.  
 Next, check that the distortion is less than 1.3%.

< DECK SECTION >  
 10. Tape Speed Adjustment (DECK 2)  
 Settings : • Test tape : TTA-100  
 • Test point : TP8(Lch), TP9(Rch)  
 • Adjustment location : SFR1  
 Method : Play back the test tape and adjust SFR1 so that the frequency counter reads 3000Hz  $\pm$  5Hz and  $\pm$  45Hz (REV) with respect to forward speed.

11. Head Azimuth Adjustment (DECK 1, DECK 2)  
 Settings : • Test tape : TTA-330  
 • Test point : TP8(Lch), TP9(Rch)  
 • Adjustment location : Head azimuth adjustment screw  
 Method : Play back (FWD) the 8kHz signal of the test tape and adjust screw so that the output becomes maximum. Next, perform on REV PLAY mode.

12. PB Frequency Response Check (DECK 1, DECK 2)  
 Settings : • Test tape : TTA-300  
 • Test point : TP8(Lch), TP9(Rch)  
 Method : Play back the 315Hz and 8kHz signals of the test tape and check that the output ratio of the 8kHz signal with respect to that of the 315Hz signal is within 5dB.

13. PB Sensitivity Check (DECK 1, DECK 2)  
 Settings : • Test tape : TTA-200  
 • Test point : TP8(Lch), TP9(Rch)  
 Method : Play back the test tape and check that the output level of the test point is 140mV  $\pm$  3dB.

14. REC/PB Frequency Response Adjustment (DECK 2)  
 Settings : • Test tape : TTA-602  
 • Test point : TP8(Lch), TP9(Rch)  
 • Input signal : 1kHz / 8kHz (LINE IN)  
 • Adjustment location : SFR451 (Lch) SFR452 (Rch)  
 Method : Apply a 1kHz signal and REC mode. Then adjust OSC attenuator so that the output level at the TP8, TP9 becomes -20VU. Record and play back the 1kHz and 8kHz signals and adjust SFRs so that the output of the 8kHz signals becomes 0dB  $\pm$  0.5dB with respect to that of the 1kHz signal.

15. REC/PB Sensitivity Check (DECK 2)  
 Settings : • Test tape : TTA-602  
 • Test point : TP8(Lch), TP9(Rch)  
 • Input signal : 1kHz (LINE IN)  
 Method : Apply a 1kHz signal and REC mode. Then adjust OSC attenuator so that the output level at TP8, TP9 becomes 0VU. Record and play back the 1kHz signals and check that the output is -2dB  $\pm$  3.0dB.

< FRONT SECTION >  
 16.  $\mu$ -CON OSC Adjustment  
 Settings : • Test point : TP7 and GND  
 • Adjustment location : L331  
 Method : Insert AC plug while pressing POWER and TUNER function keys. Adjust L331 so that the frequency at the test point is 153.84kHz  $\pm$  0.15Hz.

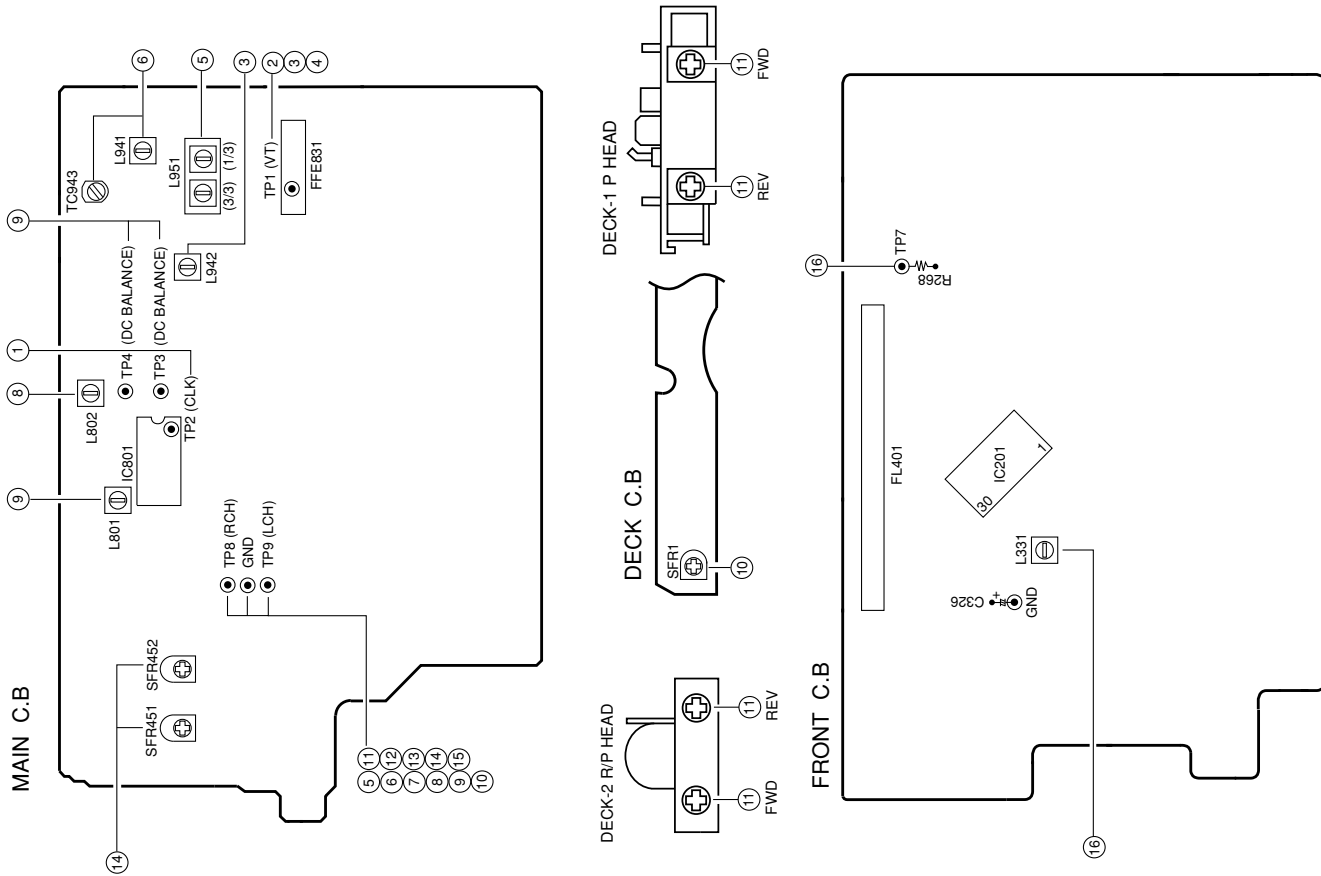



# MECHANICAL MAIN PARTS LIST 1/1

DESCRIPTIONで判断できない物は"REFERENCE NAME LIST"を参照してください。  
If can't understand for Description please kindly refer to "REFERENCE NAME LIST".

REF. NO	PART NO.	KANRI NO.	DESCRIPTION	REF. NO	PART NO.	KANRI NO.	DESCRIPTION
1	8A-NF8-014-010		WINDOW, CASS 1 <50EZSM, 50HASM, 52EZSM>	36	8A-NF8-029-010		KEY, OPEN<50EZSM, 50HASM, 52EZSM>
2	8A-NF8-015-010		WINDOW, CASS 2<50EZSM, 50HASM, 52EZSM>	37	87-NF4-216-010		HLDL, LOCK 1<50EZSM, 50HASM, 52EZSM>
3	8A-NF8-042-010		BOX, CASS 1H<50EZSM, 50HASM, 52EZSM>	38	86-NF9-224-010		SPR-C, LOCK<50EZSM, 50HASM, 52EZSM>
4	8A-NF8-004-010		BOX, CASS 2 U<50EZSM, 52EZSM>	39	82-NF5-229-010		PLATE, LOCK<50EZSM, 50HASM, 52EZSM>
4	8A-NF8-043-010		BOX, CASS 2H<50HASM>	40	87-NF4-217-110		HLDL, LOCK 2<50EZSM, 50HASM, 52EZSM>
5	8A-NF8-207-010		SPR-T, EJECT 1<EXCEPT 50HASM>	41	8A-NF8-206-010		HLDL, PWB M
5	82-NF5-218-010		SPR-T, EJECT 1 (SIN)<50HASM>	42	88-906-251-110		FF-CABLE, 6P 1.25
6	8A-NF8-208-010		SPR-T, EJECT 2<EXCEPT 50HASM>	43	8A-NF8-205-010		HLDL, IC
6	82-NF5-219-010		SPR-T, EJECT 2 (SIN)<50HASM>	44	87-064-185-010		HLDL, WIRE
7	81-532-080-010		LABEL, CASS. COMPT <50EZSM, 50HASM, 52EZSM>	45	84-ZG1-245-210		CAP, OPTICAL
8	8A-NF8-019-010		KNOB, RTRY JOG<50EZSM, 50HASM, 52EZSM>	46	8A-NF8-065-110		CABI, REAR EZSE<50EZSE>
9	8Z-NF6-210-010		DMPR, 150 N<50HASM>	46	8A-NF8-064-110		CABI, REAR EZSE R<52EZSE>
9	8A-NF8-209-010		OIL-DMPR, 120<50EZSM, 52EZSM>	46	8A-NF8-069-110		CABI, REAR EZSM<50EZSM>
10	8A-NF8-001-010		CABI, FR U<50EZSM, 50HASM, 52EZSM>	46	8A-NF8-070-110		CABI, REAR EZSM R<52EZSM>
11	8A-NF8-034-010		PANEL, DIRECT<50EZSM, 50HASM, 52EZSM>	46	8A-NF8-072-110		CABI, REAR HASM<50HASM>
12	8A-NF8-030-010		KNOB, RTRY MIC<50HASM>	46	8A-NF8-063-110		CABI, REAR KSE<50KSE>
13	8A-NF8-045-010		PANEL, FR E<52EZSM>	47	8A-DB8-209-010		HLDL, PWB PT
13	8A-NF8-044-010		PANEL, FR H<50HASM>	48	8A-NF8-608-010		PT, ANF-8 EZ<EXCEPT 50HASM>
13	8A-NF8-048-010		PANEL, FR K<50EZSM>	48	8A-NF8-605-010		PT, ANF-8 LH<50HASM>
14	8A-NF8-047-010		WINDOW, DISP E<52EZSM>	49	87-NF4-221-010		HLDL, CABLE
14	8A-NF8-046-010		WINDOW, DISP H<50EZSM, 50HASM>	50	87-085-185-010		BUSHING, AC CORD (E)
15	87-CE3-023-010		BADGE, AIWA 30N SILV <50EZSM, 50HASM, 52EZSM>	51	87-A80-105-010		AC CORD ASSY, AZ<50HASM>
16	8A-NF8-009-010		PANEL, CD<50EZSM, 50HASM, 52EZSM>	51	87-A80-143-010		AC CORD ASSY, E BLK<50KSE>
17	8A-NF8-007-010		PANEL, LEFT V-2	51	87-A80-092-010		AC CORD ASSY, E BLK SUN FAI <EXCEPT 50KSE, 50HASM>
18	8A-NF8-005-010		PANEL, TOP	52	8Z-NB8-240-010		COVER, PL
19	8A-NF8-006-010		WINDOW, TOP	53	8A-NF8-008-010		PANEL, RIGHT V-2
20	8A-NF8-010-010		PANEL, TRAY	54	87-064-080-010		WIRE, BINDER
21	8A-NF8-011-010		WINDOW, TRAY	55	85-NF7-599-010		PVC W 3.2-8-0.3
22	88-NF8-205-010		GUIDE, FL<50EZSM, 50HASM, 52EZSM>	56	87-NF6-615-010		CONN ASSY, 3P PB<50HASM>
23	8A-NF8-020-010		KEY, FUN<50EZSM, 50HASM, 52EZSM>	57	87-NF6-616-010		CONN ASSY, 8P RPB<50HASM>
24	8A-NF8-018-010		REFLECTOR, FUN<50EZSM, 50HASM, 52EZSM>	A	87-067-703-010		TAPPING SCREW, BVT2+3-10
25	8A-NF8-016-010		KEY, POWER<50EZSM, 50HASM, 52EZSM>	B	87-NF4-224-010		S-SCREW, IT3B+3-8 CU
26	8A-NF8-031-010		KEY, DISC<50EZSM, 50HASM, 52EZSM>	C	87-067-581-010		TAPPING SCREW, BVT2+3-15
27	8A-NF8-032-010		CAP, DISC<50EZSM, 50HASM, 52EZSM>	D	87-067-688-010		BVTT+3-6
28	8A-NF8-017-010		REFLECTOR, ECO<50EZSM, 50HASM, 52EZSM>	E	87-723-096-410		QT2+3-10W/O SLOT BL
29	8A-NF8-022-010		KEY, GEQ<50EZSM, 50HASM, 52EZSM>	F	87-067-641-010		UTT2+3-8 (W/O SLOT) BL
30	8A-NF8-036-010		KEY, ASSY OPE REV <50EZSM, 50HASM, 52EZSM>	G	87-078-191-010		S-SCREW, IT+4-10
31	8A-NF8-203-010		GUIDE, OPE REV<50EZSM, 50HASM, 52EZSM>	H	87-721-097-410		QT2+3-12 GLD
32	8A-NF8-201-010		GUIDE, FUN<50EZSM, 50HASM, 52EZSM>	I	87-721-096-410		QT2+3-10 GLD<50EZSE, 52EZSE>
33	88-915-101-110		FF-CABLE, 15P 1.25 100MM<50HASM>				
33	88-911-101-110		FF-CABLE, 11P 1.25<50EZSM, 52EZSM>				
34	88-913-301-110		FF-CABLE, 13P-1.25 <50EZSM, 50HASM, 52EZSM>				
35	8A-NF8-038-010		KEY, CD EDIT E<52EZSM>				
35	8A-NF8-037-010		KEY, CD EDIT H<50HASM>				
35	8A-NF8-028-010		KEY, CD EDIT U<50EZSM>				

## COLOR NAME TABLE

Basic color symbol	Color	Basic color symbol	Color	Basic color symbol	Color
B	Black	C	Cream	D	Orange
G	Green	H	Gray	L	Blue
LT	Transparent Blue	N	Gold	P	Pink
R	Red	S	Silver	ST	Titan Silver
T	Brown	V	Violet	W	White
WT	Transparent White	Y	Yellow	YT	Transparent Yellow
LM	Metallic Blue	LL	Light Blue	GT	Transparent Green
LD	Dark Blue	DT	Transparent Orange	GM	Metallic Green
YM	Metallic Yellow	DM	Metallic Orange	PT	Transparent Pink

# TAPE MECHANISM MAIN PARTS LIST 1/1 <50HA: 2ZM-3MK2 PR4NM>

DESCRIPTIONで判断できない物は "REFERENCE NAME LIST" を参照してください。  
 If can't understand for Description please kindly refer to "REFERENCE NAME LIST".

REF. NO	PART NO.	KANRI NO.	DESCRIPTION	REF. NO	PART NO.	KANRI NO.	DESCRIPTION
1	82-ZM3-301-610	1H	CHAS ASSY,M2	31	82-ZM1-255-310	0E	SPR-E,LVR DIR
2	82-ZM1-258-210	0E	SPR-T,PINCH L	32	82-ZM3-305-210	0E	GEAR,CAM M2
3	82-ZM1-341-210	1A	LVR ASSY,PINCH L2	33	82-ZM1-227-310	0E	LVR,TRIG
4	82-ZM1-333-210	0E	PLATE,LINK2	34	82-ZM3-306-110	0E	LVR,FR M2
5	82-ZM1-266-310	0E	LVR,DIR	35	82-ZM1-265-310	0E	SPR-E,TRIG
6	82-ZM1-214-010	0E	SPR-T,DIR	36	82-ZM3-339-110	0E	SHAFT,COUPLER N3
7	82-ZM1-206-910	1A	CHAS,HEAD	37	86-ZM1-206-010	0E	BELT,MAIN L
8	82-ZM3-335-310	0E	PULLEY,COUPLER M3	38	82-ZM1-322-010	0E	SPR-T,FR 60
9	82-ZM1-269-210	0E	SPR-T,BRG	39	82-ZM1-220-210	0E	GEAR,IDLER
10	82-ZM1-219-110	0E	SPR-T,LINK	40	82-ZM3-616-010	0E	RING MAGNET 4
11	82-ZM1-210-110	0E	GEAR,H T	41	82-ZM1-216-410	0E	GEAR,REEL
12	82-ZM1-213-010	0E	SPR-T,HEAD	42	87-A90-820-010	1D	HEAD,PH HADKH25 FPC
13	82-ZM1-207-910	1A	GUIDE,TAPE	42	87-A90-821-010	1H	HEAD,RPH HADKH56 FPC
14	86-ZM4-206-010	0E	S-SCREW,AZIMUTH L	43	82-ZM1-225-210	0E	GEAR,FR
15	82-ZM1-314-110	0E	PLATE,HEAD	44	82-ZM1-226-010	0E	GEAR,REW
16	82-ZM1-208-310	0E	HLDR,HEAD	45	82-ZM3-333-310	1A	SLIP DISK ASSY 2
17	82-ZM1-218-010	0E	SPR-E,HB	46	82-ZM1-338-110	0E	BELT,FR 4
18	82-ZM3-342-010	0E	BELT,SBU MOT 3	47	82-ZM1-349-110	1A	FLY-WHL,R W
19	82-ZM1-222-210	0E	LVR,PLAY	47	82-ZM1-348-110	0E	FLY-WHL,L W
20	82-ZM1-217-410	0E	REEL TABLE	48	82-ZM3-338-310	1A	FLY-WHL,R3W
21	82-ZM1-244-510	0E	SPR-C,BT	49	82-ZM3-329-410	0E	BELT,SBU R2
22	82-ZM1-285-410	0E	SPR-C,BT L	50	82-ZM1-618-410	1B	SOL ASSY,27
23	82-ZM1-257-010	0E	SPR-T,CAS	51	87-045-347-010	1H	MOT,SHU2L 70
24	82-ZM1-241-310	0E	LVR,MC	52	82-ZM3-221-210	0E	PULLEY,MOT 2M
25	82-ZM1-242-010	0E	LVR,CAS	A	85-ZM3-202-010	0E	S-SCREW,TG
26	82-ZM1-243-010	0E	LVR,STOP	B	80-ZM6-207-010	0E	V+1.6-7
27	82-ZM1-344-010	0E	LVR ASSY,PINCH R2	C	82-ZM3-318-110	0E	S-SCREW W,MOTOR M2
28	82-ZM1-259-210	0E	SPR-T,PINCH R	D	87-B10-043-010	0E	W-P,0.99-4-0.25 SLT
29	82-ZM1-240-110	0E	LVR,REC(*)	E	82-ZM3-334-010	0E	PW 2.16-6-0.4
30	80-ZM6-243-010	0E	SH 1.75-3.6-0.5 SLT				

TAPE MECHANISM EXPLODED VIEW 1/1 <50HA: 2ZM-3MK2 PR4NM>

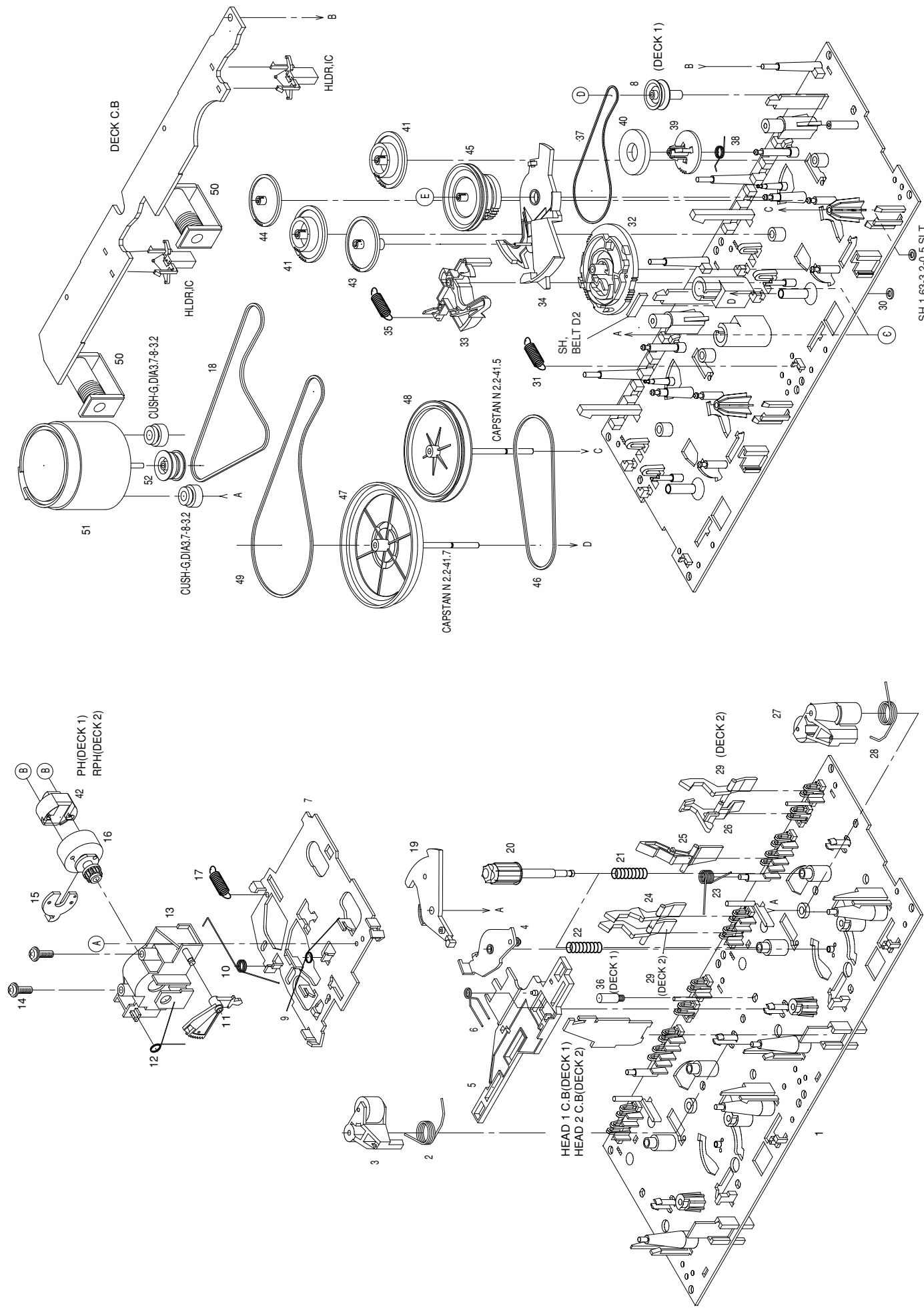

TAPE MECHANISM EXPLODED VIEW 1/1 <50EZ/50K/52EZ: 6ZM-3 PR2NM>

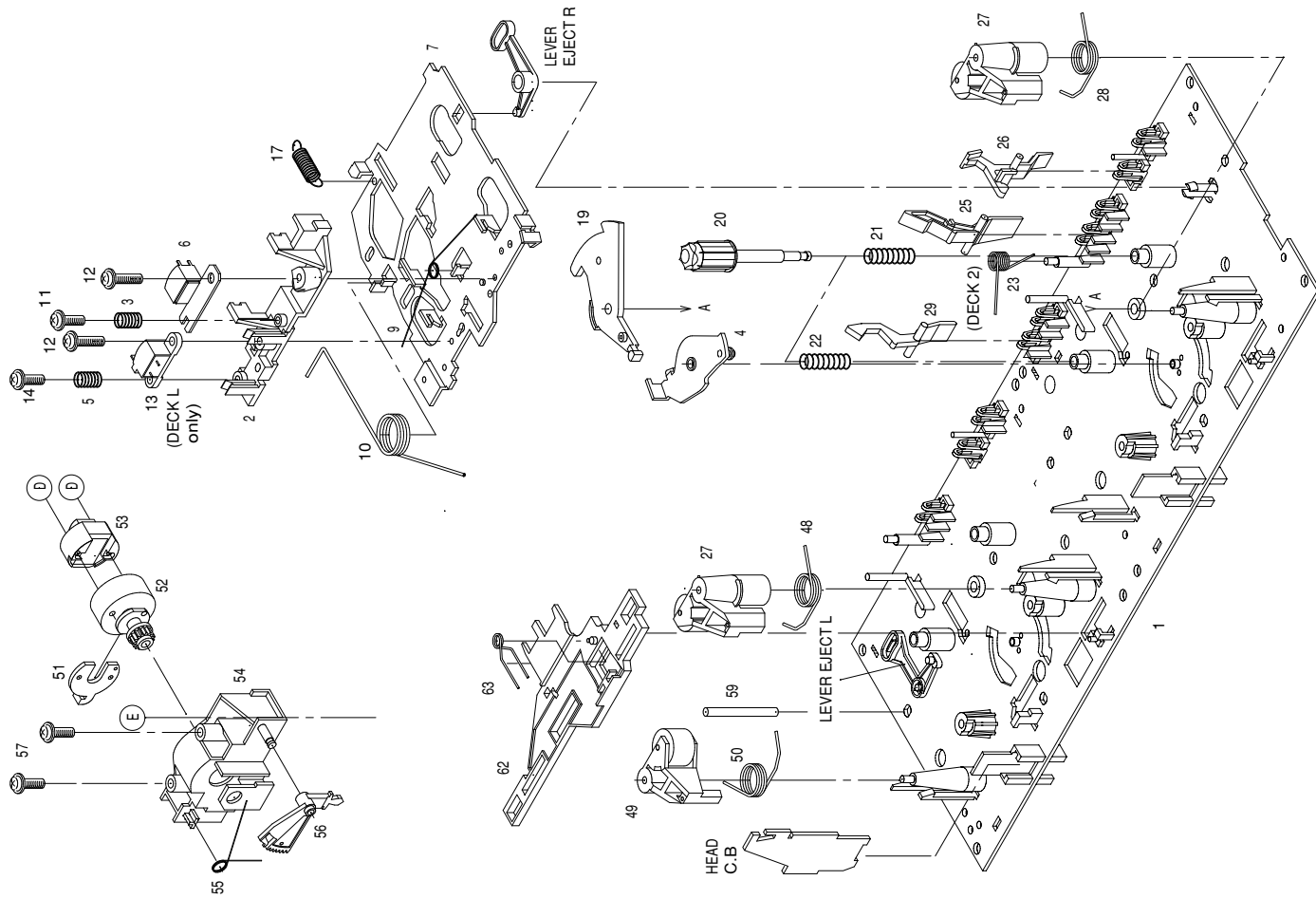
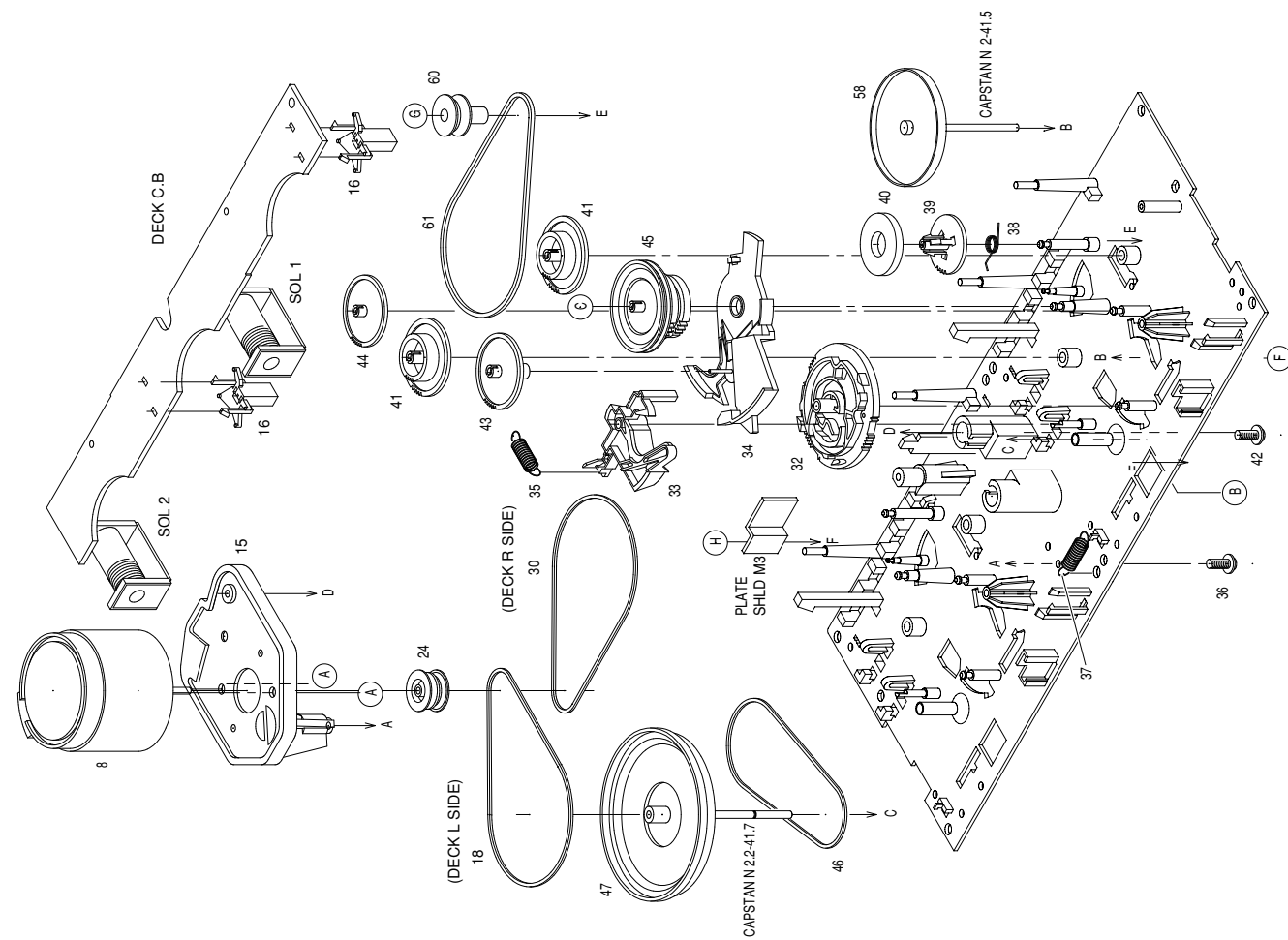



# TAPE MECHANISM MAIN PARTS LIST 1/1 <50EZ/50K/52EZ: 6ZM-3 PR2NM>

DESCRIPTIONで判断できない物は "REFERENCE NAME LIST" を参照してください。  
 If can't understand for Description please kindly refer to "REFERENCE NAME LIST".

REF. NO	PART NO.	KANRI NO.	DESCRIPTION	REF. NO	PART NO.	KANRI NO.	DESCRIPTION
1	86-ZM3-215-010	1E	CHAS ASSY,RS	41	82-ZM1-216-310	0E	GEAR, REEL
2	86-ZM3-202-010	0E	BASE, HEAD S	42	86-ZM3-213-010	0E	S-SCREW, HLDR, MOT 3
3	86-ZM3-205-010	0E	SPR-C, RPH S	43	82-ZM1-225-210	0E	GEAR, FR
4	82-ZM1-333-210	0E	PLATE, LINK 2	44	82-ZM1-226-010	0E	GEAR, REW
5	86-ZM3-206-010	0E	SPR-C, EH S	45	82-ZM3-333-310	1B	SLIP DISK ASSY 2
6	87-A90-403-010	1B	HEAD, RPH MS15R	46	82-ZM1-338-010	0E	BELT FR4
7	86-ZM3-201-010	1A	CHAS, HEAD S (DECK L)	47	82-ZM1-349-010	1A	FLY-WHL RW (DECK L)
7	82-ZM3-206-210	1A	BELT, R	47	82-ZM3-338-010	1A	FLY-WHL R3W (DECK R)
8	87-045-347-010	1H	MOT, SHU2L 70 (M1)	48	82-ZM1-259-210	0E	SPR-T, PINCH R
9	82-ZM1-269-210	0E	SPR-T, BRG	49	82-ZM1-341-110	1A	LVR ASSY, PINCH L2
10	82-ZM1-219-110	0E	SPR-T, LINK	50	82-ZM1-258-210	0E	SPR-T, PINCH L
11	86-ZM3-209-010	0E	S-SCREW, ASIMUTHS	51	82-ZM1-314-110	0E	PLATE, HEAD
12	86-ZM3-207-010	0E	S-SCREW, RPH	52	82-ZM1-208-310	0E	HLDR, HEAD
13	87-A90-404-010	0E	HEAD, EH LE15B	53	87-A90-366-010	1D	HEAD, PH YK50P-BF414
14	86-ZM3-208-010	0E	S-SCREW, EH	54	82-ZM1-207-810	0E	GUIDE TAPE
15	86-ZM3-203-010	1B	HLDR, MOTS	55	82-ZM1-213-010	0E	SPR-T, HEAD
16	82-ZM1-245-210	0E	HLDR, IC	56	82-ZM1-210-110	0E	GEAR, HT
17	82-ZM1-218-010	0E	SPR-E, HB	57	86-ZM4-206-010	0E	S-SCREW AZIMUTH L
18	86-ZM3-214-010	0E	BELT, SUB RR	58	82-ZM1-348-010	1A	FLY-WHL, LW
19	82-ZM1-222-210	0E	LVR, PLAY	59	82-ZM3-339-010	0E	SHAFT, COUPLER N3
20	82-ZM1-217-410	0E	REEL TABLE	60	82-ZM3-335-210	0E	PULLEY, COUPLER M3
21	82-ZM1-244-510	0E	SPR-C, BT	61	86-ZM1-206-010	0E	BELT, MAIN L
22	82-ZM1-285-410	0E	SPR-C, BT L	62	82-ZM1-266-110	0E	LVR, DIR
23	82-ZM1-257-010	0E	SPR-T, CAS	63	82-ZM1-214-010	0E	SPR-T, DIR
24	82-ZM3-221-010	0E	PULLEY, MOT 2M	A	87-251-071-410	0E	U+2.6-4
25	82-ZM1-242-010	0E	LVR, CAS	B	80-ZM6-243-010	0E	SH, 1.75-3.6-0.5 SLT
26	82-ZM1-243-010	0E	LVR, STOP	C	82-ZM3-334-010	0E	PW, 2.16-6-0.4
27	82-ZM1-344-110	1A	LVR ASSY, PINCH	D	80-ZM6-207-010	0E	V+1.6-7
28	86-ZM3-204-010	0E	SPR-T, PINCHDS	E	85-ZM3-202-010	0E	S-SCREW TG
29	82-ZM1-240-110	0E	LVR, REC (DECK 2)	F	82-ZM1-288-010	0E	SH, 1.63-3.2-0.5 SLT
30	86-ZM3-210-010	0E	BELT, RS	G	87-B10-043-010	0E	W-P, 0.99-4-0.25 SLT
32	82-ZM3-305-110	0E	GEAR, CAM M2	H	87-571-032-410	0E	VIT+2-3
33	82-ZM1-227-310	0E	LVR, TRIG				
34	82-ZM3-306-110	0E	LVR, FR M2				
35	82-ZM1-265-110	0E	SPR-E, TRIG				
36	87-761-073-410	0E	VFT2+2.6-6 W/O SLOT				
37	82-ZM1-255-310	0E	SPR-E, LVR DIR				
38	82-ZM1-322-010	0E	SPR-T, FR60				
39	82-ZM1-220-210	0E	GEAR, IDLER				
40	82-ZM3-616-010	0E	RING MAGNET 4				

# SPEAKER DISASSEMBLY INSTRUCTIONS

## Type.1

Insert a flat-bladed screwdriver into the position indicated by the arrows and remove the panel. Remove the screws of each speaker unit and then remove the speaker units.

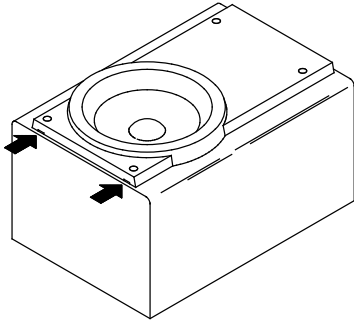

## Type.2

Remove the grill frame and four pieces of rubber caps by pulling out with a flat-bladed screwdriver. Remove the screws from hole where installed rubber caps. Insert a flat-bladed screwdriver into the position indicated by the arrows and remove the panel. Remove the screws of each speaker unit and then remove the speaker units.

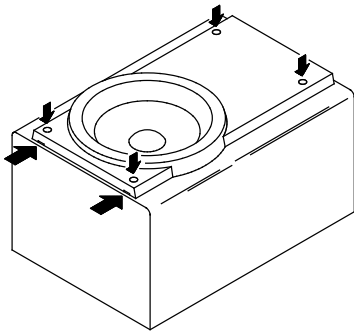

## Type.3

Insert a flat-bladed screwdriver into the position indicated by the arrows and remove the panel. Turn the speaker unit to counter-clockwise direction while inserting a flat-bladed screwdriver into one of the hollows around speaker unit, and then remove the speaker unit. After replacing the speaker unit, install it turning to clockwise

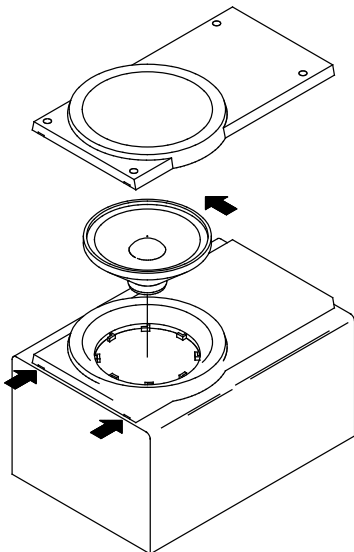

## Type.4

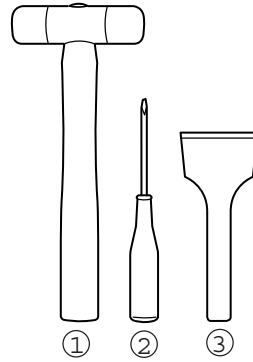

### TOOLS

- ① Plastic head hammer
- ② (⊖) flat head screwdriver
- ③ Cut chisel

## How to Remove the PANEL, FR

1. Insert the (⊖) flat head screwdriver tip into the gap between the PANEL, FR and the PANEL, SPKR. Tap the head of the (⊖) flat head screwdriver with the plastic hammer head, and create the clearance as shown in Fig-1.
2. Insert the cut chisel in the clearance, and tap the head of the cut chisel with plastic hammer as shown in Fig-2, to remove the PANEL, FR.
3. Place the speaker horizontally. Tap head of the cut chisel with plastic hammer as shown in Fig-3, and remove the PANEL, FR completely.

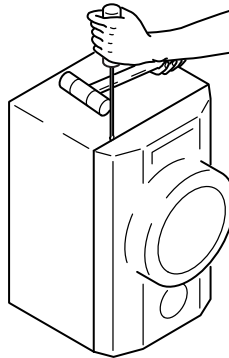

Fig-1

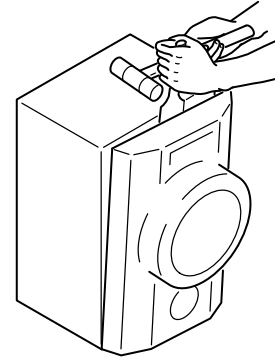

Fig-2

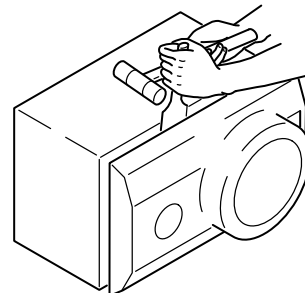

Fig-3

## How to Attach the PANEL, FR

Attach the PANEL, FR to the PANEL, SPKR. Tap the four corners of the PANEL, FR with the plastic hammer to fit the PANEL, FR into the PANEL, SPKR completely.

## SPEAKER PARTS LIST <SX-WNSZ50, SX-WNSZ52>

DESCRIPTIONで判断できない物は "REFERENCE NAME LIST" を参照してください。  
If can't understand for Description please kindly refer to "REFERENCE NAME LIST".

REF. NO	PART NO.	KANRI NO.	DESCRIPTION
1	8A-DS8-001-010		PANEL,FR
2	8A-DS8-004-010		PANEL,DUCT
3	8A-DS8-005-010		GRILLE,FRAME ASSY
4	8A-DS8-009-010		PROTECTOR,
5	88-NS5-610-010		CORD,SPKR
6	88-NS5-611-010		CORD,SPKR B/L
7	8Z-NSY-003-010		CORD,BUSH
8	88-NS3-029-010		CORD,BUSH L
9	8Z-NS7-602-010		SPKR, W 160
10	8Z-NSY-604-010		SPKR, M 100
11	8Z-NSY-608-010		SPKR, CERAMIC ASSY
12	8A-NSJ-006-010		BADGE,AIWA S35



**アイワ株式会社** 〒110-8710 東京都台東区池之端1-2-11 ☎03(3827)3111 (代表)  
**AIWA CO.,LTD.** 2-11, IKENOHATA 1-CHOME, TAITO-KU, TOKYO 110, JAPAN TEL:03 (3827) 3111