

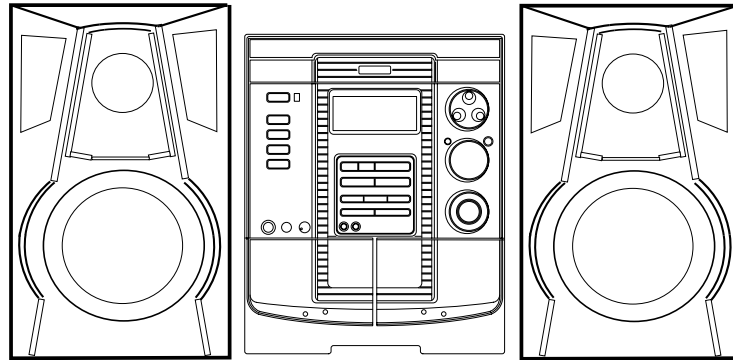

NSX-SZ310 HS
NSX-SZ319 LH
NSX-SZ519 HA



SERVICE MANUAL

COMPACT DISC
STEREO SYSTEM

BASIC TAPE MECHANISM : ZZM-3
BASIC CD MECHANISM : BZG-5

SYSTEM	CD CASSEIVER	MAIN SPEAKERS	TAPE MECHANISM	CD MECHANISM	REMOTE CONTROLLER
NSX-SZ310	CX-NSZ310	SX-NSZ312	ZZM-3 PR1NF	BZG-5 ZD3NFD	RC-ZAS02
NSX-SZ319	CX-NSZ319	SX-NSZ319	ZZM-3 YPR1NM	BZG-5 YZD3NM	
NSX-SZ519	CX-NSZ519	SX-NSZ702	ZZM-3 YPR1NM	BZG-5 YZD3NCM	

- This Service Manual contains information about the difference between NSX-SZ310 (HS) / NSX-SZ319 (LH) / NSX-SZ519 (HA) and NSX-SZ310 (LH). If requiring other information, see Service Manual of NSX-AJ310 (U) / NSX-SZ310 (K,EZ,LH) / NSX-SZ315 (EZ) / NSX-SZ510 (LH), (S/M Code No. 09-012-442-0R1).
- If requiring information about the CD mechanism, see Service Manual of BZG-5 ZD3NFD/YZD3NM, (S/M Code No. 09-00C-353-3N2), BZG-5 YZD3NCM, (S/M Code No. 09-00C-353-3N4).

aiwa
S/M Code No. 09-014-442-0S2

SUPPLEMENT
DATA

SPECIFICATIONS

<FM tuner section>

Tuning range	87.5 MHz to 108 MHz
Usable sensitivity (IHF)	13.2 dBf
Antenna terminals	75 ohms (unbalanced)

<AM tuner section>

Tuning range	530 kHz to 1710 kHz (10 kHz step) 531 kHz to 1602 kHz (9 kHz step)
Usable sensitivity	350 μ V/m
Antenna	Loop antenna

<Amplifier section>

CX-NSZ310:

Power output	32 W + 32 W (6 ohms, T.H.D. 1 %, 1 kHz) 40 W + 40 W (6 ohms, T.H.D. 10 %, 1 kHz)
Total harmonic distortion	0.08 % (20 W, 1 kHz, 6 ohms, DIN AUDIO)

CX-NSZ319:

Power output	Rated : 62 W + 62 W (6 ohms, T.H.D. 1 %, 1 kHz) Reference : 80 W + 80 W (6 ohms, T.H.D. 10 %, 1 kHz)
Total harmonic distortion	0.08 % (40 W, 1 kHz, 6 ohms, AUDIO DIN)

CX-NSZ519:

Power output	Rated : 85 W + 85 W (6 ohms, T.H.D. 1 %, 1 kHz) Reference : 100 W + 100 W (6 ohms, T.H.D. 10 %, 1 kHz)
Total harmonic distortion	0.08 % (40 W, 1 kHz, 6 ohms, DIN AUDIO)

Inputs VIDEO / AUX : 500 mV

<HS only> MIC : 1.0 mV (10 kohms)

Outputs SPEAKERS : 6 ohms or more

PHONES : 32 ohms or more

<Cassette deck section>

Track format	4 tracks, 2 channels stereo
Frequency response	50 Hz - 15 kHz
Recording system	AC bias
Heads	Deck 1 : Playback head x 1 Deck 2 : Recording / Playback x 1, erase head x 1

<Compact disc player section>

Laser	Semiconductor laser ($\lambda = 780$ nm)
D-A converter	1 bit dual
Signal-to-noise ratio	85 dB (1 kHz, 0 dB)
Harmonic distortion	0.05 % (1 kHz, 0 dB)

<General>

CX-NSZ310

Power requirements	220 V AC, 60 Hz
Power consumption	70 W
Power consumption in standby mode	With ECO mode on : 0.6 W With ECO mode off : 14 W
Dimensions of main unit (W x H x D)	260 x 324 x 341.5 mm
Weight	6.2 kg

CX-NSZ319

Power requirements	120 V/220 - 230 V/240 V AC, (Switchable), 50 Hz/60 Hz
Power consumption	90 W
Power consumption in standby mode	With ECO mode on : 0.6 W With ECO mode off : 19 W
Dimensions of main unit (W x H x D)	260 x 324 x 339 mm
Weight	6.8 kg

CX-NSZ519

Power requirements	120 V/220 - 230 V/240 V AC, (Switchable), 50 Hz/60 Hz
Power consumption	105 W
Power consumption in standby mode	With ECO mode on : 0.6 W With ECO mode off : 20 W
Dimensions of main unit (W x H x D)	260 x 324 x 339 mm
Weight	7.2 kg

<Speaker system SX-NSZ312 (for NSX-SZ310)>

Speaker system	3 way, bass reflex (magnetic shielded)
Speaker units	Woofer : 140 mm cone Tweeter : 60 mm cone Super tweeter : 20 mm ceramic
Impedance	6 ohms
Dimensions (W x H x D)	220 x 324 x 225 mm
Weight	3.6 kg

<Speaker system SX-NSZ319 (for NSX-SZ319)>

Speaker system	3 way, bass reflex (magnetic shielded)
Speaker units	Woofer : 140 mm cone Tweeter : 60 mm cone Super tweeter : 20 mm ceramic
Impedance	6 ohms
Dimensions (W x H x D)	220 x 324 x 225 mm
Weight	4.3 kg

<Speaker system SX-NSZ702 (for NSX-SZ519)>

Speaker system	2 way, bass reflex (magnetic shielded)
Speaker units	Woofer : 160 mm cone Tweeter : 60 mm cone
Impedance	6 ohms
Dimensions (W x H x D)	230 x 324 x 253 mm
Weight	4.6 kg

• Design and specifications are subject to change without notice.

• The word "BBE" and the "BBE symbol" are trademarks of BBE Sound, Inc.

Under license from BBE Sound, Inc.

ELECTRICAL MAIN PARTS LIST

REF. NO.	PART NO.	KANRI NO.	DESCRIPTION	REF. NO.	PART NO.	KANRI NO.	DESCRIPTION
IC				C20	87-A12-036-000		CAP, E 2200-63<LH>
	87-A21-269-010		IC, EW732	C21	87-A12-777-090		CAP, E 3300-25<LH, HS>
	87-A21-419-040		C-IC, NJM14558MD-TE2	C21	87-A10-520-000		CAP, E 3300-35 M SMG<HA>
	87-A21-893-040		C-IC, NJM14558V-TE2	C22	87-A12-777-090		CAP, E 3300-25<LH, HS>
	87-A21-401-040		C-IC, M61503FP	C22	87-A10-520-000		CAP, E 3300-35 M SMG<HA>
	87-A21-695-010		IC, LA1845L	C25	87-A12-072-080		CAP, E 100-25 SMG<LH, HS>
	8B-NF9-601-030		C-IC, UPD780226GF-021-3BA	C26	87-A12-072-080		CAP, E 100-25 SMG<LH, HS>
	87-A21-218-110		IC, NJL64H380A	C27	87-A12-072-080		CAP, E 100-25 SMG<LH, HS>
	87-A21-928-010		IC, LC72131D-N	C28	87-A12-072-080		CAP, E 100-25 SMG<LH, HS>
				C30	87-A12-095-080		CAP, E 100-50<LH, HS>
TRANSISTOR				C31	87-A12-062-080		CAP, E 100-10 SMG
	87-A30-494-080		TR, 2SA1980G	C32	87-012-286-080		CAP, U 0.01-25
	87-A30-559-010		TR, CSB1370EF	C34	87-A12-072-080		CAP, E 100-25 SMG
	87-A30-076-080		C-TR, 2SC3052F	C35	87-A12-071-080		CAP, E 47-25 SMG
	87-A30-075-080		C-TR, 2SA1235F	C36	87-A12-067-080		CAP, E 330-16 SMG
	87-A30-107-070		C-TR, CMBT5401	C38	87-012-286-080		CAP, U 0.01-25
	87-A30-484-080		C-TR, KRA102S	C60	87-A12-089-080		CAP, E 3.3-50 SMG
	87-A30-468-080		C-TR, KRC102S-RTK	C61	87-A12-071-080		CAP, E 47-25 SMG
	87-A30-190-080		TR, CC5551	C83	87-A12-068-080		CAP, E 470-16<HS>
	87-A30-106-040		C-TR, CMBT5551	C83	87-A12-074-080		CAP, E 470-25<HA, LH>
	87-A30-528-010		TR, 2SB1686	C97	87-010-831-080		C-CAP, U, 0.1-16F
	87-A30-529-010		TR, 2SD2642	C101	87-012-278-080		C-CAP, U 2200P-50<HS>
	87-A30-162-010		FET, 2SK2937	C101	87-012-279-080		C-CAP, U 2700P-50<HA, LH>
	87-A30-091-080		FET, 2SJ460	C102	87-012-278-080		C-CAP, U 2200P-50<HS>
	87-A30-090-080		FET, 2SK2541	C102	87-012-279-080		C-CAP, U 2700P-50<HA, LH>
	87-A30-062-080		C-TR, KRC104S	C103	87-A12-084-080		CAP, E 0.22-50 SMG
	87-A30-495-080		TR, 2SA1981Y	C104	87-A12-084-080		CAP, E 0.22-50 SMG
	87-A30-087-080		C-FET, 2SK2158	C107	87-A12-089-080		CAP, E 3.3-50 SMG
	87-A30-582-080		TR, CDA1585BC	C108	87-A12-089-080		CAP, E 3.3-50 SMG
	87-026-610-080		TR, KTC3198GR	C111	87-A12-077-080		CAP, E 33-35 SMG
	87-A30-288-040		C-TR, DTC114YKA	C112	87-A12-077-080		CAP, E 33-35 SMG
	89-327-143-080		TR, 2SC27140	C113	87-A10-596-080		C-CAP, S 100P-100<HA, LH>
	87-A30-489-080		C-TR, KRA107S	C113	87-012-195-080		C-CAP, U 100P-50<HS>
	89-503-602-080		C-FET, 2SK360E	C114	87-A10-596-080		C-CAP, S 100P-100<HA, LH>
	87-A30-615-080		TR, STC250	C114	87-012-195-080		C-CAP, U 100P-50<HS>
	87-A30-234-080		TR, CSC4115BC	C117	87-012-368-080		C-CAP, S 0.1-50 F
DIODE				C118	87-012-368-080		C-CAP, S 0.1-50 F
	87-A40-393-090		DIODE, 1N5402GW (F20)	C119	87-012-286-080		CAP, U 0.01-25
	87-A40-291-080		DIODE, 1N4148M (CPT)	C120	87-012-286-080		CAP, U 0.01-25
	87-A40-454-090		DIODE, 1N5393 GW 12.5<HS>	C123	87-010-177-080		C-CAP, S 820P-50 SL
	87-A40-455-090		DIODE, RL203 GW<LH>	C124	87-010-177-080		C-CAP, S 820P-50 SL
	87-A40-553-080		DIODE, 1N4003 LES	C133	87-012-282-080		CAP, U 4700P-50
	87-A40-776-080		ZENER, UZ27BSD	C140	87-012-278-080		C-CAP, U 2200P-50 B
	87-A40-764-080		ZENER, UZ10BSC	C186	87-010-759-080		C-CAP, U, 0.1-25F
	87-A40-270-080		C-DIODE, MC2838	C187	87-010-866-080		CAP, E 10-63<HA, LH>
	87-A40-269-080		C-DIODE, MC2836	C187	87-010-866-080		CAP, E 10-50<HS>
	87-A40-747-080		ZENER, UZ5.1BSB	C188	87-010-866-080		CAP, E 10-63<HA, LH>
	87-A40-749-080		ZENER, UZ5.6BSB	C188	87-A12-091-080		CAP, E 10-50<HS>
	87-A40-748-080		ZENER, UZ5.6BSA	C225	87-012-368-080		C-CAP, S 0.1-50 F
	87-A40-739-080		ZENER, UZ2.7BSA	C226	87-012-368-080		C-CAP, S 0.1-50 F
	87-017-149-080		ZENER, HZS6A2L	C227	87-012-368-080		C-CAP, S 0.1-50 F
MAIN C.B				C228	87-012-368-080		C-CAP, S 0.1-50 F
C3	87-012-368-080		C-CAP, S 0.1-50 F	C241	87-010-831-080		C-CAP, U, 0.1-16F
C4	87-012-368-080		C-CAP, S 0.1-50 F	C301	87-012-275-080		C-CAP, U 1200P-50 B
C5	87-012-368-080		C-CAP, S 0.1-50 F	C302	87-012-275-080		C-CAP, U 1200P-50 B
C6	87-012-368-080		C-CAP, S 0.1-50 F	C303	87-012-275-080		C-CAP, U 1200P-50 B
C9	87-010-759-080		C-CAP, U, 0.1-25F	C304	87-012-275-080		C-CAP, U 1200P-50 B
C10	87-010-759-080		C-CAP, U, 0.1-25F	C307	87-A12-062-080		CAP, E 100-10 SMG
C11	87-010-759-080		C-CAP, U, 0.1-25F	C308	87-A12-062-080		CAP, E 100-10 SMG
C12	87-010-759-080		C-CAP, U, 0.1-25F	C309	87-012-188-080		C-CAP, U 47P-50 CH
C19	87-A12-831-000		CAP, E 2200-56 M 85 GS<HA>	C310	87-012-188-080		C-CAP, U 47P-50 CH
C19	87-A12-776-090		CAP, E 2200-50 M 85 SKR<HS>	C313	87-012-284-080		CAP, U 6800P-50
C19	87-A12-036-000		CAP, E 2200-63<LH>	C314	87-012-284-080		CAP, U 6800P-50
C20	87-A12-831-000		CAP, E 2200-56 M 85 GS<HA>	C315	87-A12-062-080		CAP, E 100-10 SMG
C20	87-A12-776-090		CAP, E 2200-50 M 85 SKR<HS>	C317	87-A12-085-080		CAP, E 0.33-50 SMG
				C318	87-A12-085-080		CAP, E 0.33-50 SMG
				C326	87-010-787-080		CAP, U 0.022-25
				C327	87-010-831-080		C-CAP, U, 0.1-16F
				C360	87-A12-087-080		CAP, E 1-50 SMG
				C399	87-A10-039-080		C-CAP, U 470P-50 J CH

REF. NO.	PART NO.	KANRI NO.	DESCRIPTION	REF. NO.	PART NO.	KANRI NO.	DESCRIPTION
C401	87-A12-083-080		CAP,E 0.1-50 SMG	C801	87-A12-089-080		CAP,E 3.3-50 SMG
C402	87-A12-083-080		CAP,E 0.1-50 SMG	C802	87-010-829-080		CAP, U 0.047-16
C403	87-012-193-080		C-CAP,U 82P-50 CH	C803	87-010-787-080		CAP, U 0.022-25
C404	87-012-193-080		C-CAP,U 82P-50 CH	C804	87-A12-062-080		CAP,E 100-10 SMG
C405	87-012-286-080		CAP, U 0.01-25	C807	87-A12-086-080		CAP,E 0.47-50 SMG
C406	87-012-286-080		CAP, U 0.01-25	C808	87-A12-087-080		CAP,E 1-50 SMG
C407	87-012-286-080		CAP, U 0.01-25	C809	87-A12-087-080		CAP,E 1-50 SMG
C408	87-012-286-080		CAP, U 0.01-25	C810	87-010-831-080		C-CAP,U,0.1-16F
C409	87-012-278-080		C-CAP,U 2200P-50 B	C814	87-012-286-080		CAP, U 0.01-25
C410	87-012-278-080		C-CAP,U 2200P-50 B	C815	87-A12-086-080		CAP,E 0.47-50 SMG
C411	87-A12-091-080		CAP,E 10-50 SMG	C816	87-A12-086-080		CAP,E 0.47-50 SMG
C412	87-A12-091-080		CAP,E 10-50 SMG	C821	87-A12-091-080		CAP,E 10-50 SMG
C452	87-A12-069-080		CAP,E 22-25 SMG	C823	87-010-177-080		C-CAP,S 820P-50
C453	87-012-279-080		C-CAP,U 2700P-50 B	C824	87-A12-090-080		CAP,E 4.7-50 SMG
C454	87-012-279-080		C-CAP,U 2700P-50 B	C825	87-010-596-080		CAP, S 0.047-16
C455	87-012-279-080		C-CAP,U 2700P-50 B	C842	87-012-286-080		CAP, U 0.01-25
C456	87-012-286-080		CAP, U 0.01-25	C844	87-012-286-080		CAP, U 0.01-25
C457	87-A12-361-080		CAP,M 5600P-100 J CP	C850	87-A12-071-080		CAP,E 47-25 SMG
C458	87-012-274-080		CHIP CAP,U 1000P-50B	C851	87-012-286-080		CAP, U 0.01-25
C459	87-012-271-080		CAP, U 560P-50	C852	87-012-286-080		CAP, U 0.01-25
C460	87-010-831-080		C-CAP,U,0.1-16F	C853	87-012-286-080		CAP, U 0.01-25
C461	87-012-158-080		C-CAP,S 390P-50 CH	C858	87-010-831-080		C-CAP,U,0.1-16F
C462	87-012-158-080		C-CAP,S 390P-50 CH	C901	87-018-145-080		CAP,TC-U 6.8P-50
C470	87-018-127-080		CAP, CER 470P-50V	C904	87-012-286-080		CAP, U 0.01-25
C605	87-012-280-080		CAP, U 3300P-50	C905	87-012-286-080		CAP, U 0.01-25
C606	87-012-280-080		CAP, U 3300P-50	C907	87-012-286-080		CAP, U 0.01-25
C609	87-010-785-080		C-CAP,U,0.015-25BK	C908	87-A10-915-080		C-CAP,U 1000P-25
C610	87-010-785-080		C-CAP,U,0.015-25BK	C909	87-012-286-080		CAP, U 0.01-25
C611	87-A12-084-080		CAP,E 0.22-50 SMG	C910	87-012-174-080		CAP CHIP U 12P-50
C612	87-A12-084-080		CAP,E 0.22-50 SMG	C911	87-012-170-080		C-CAP,U 8P-50
C613	87-A12-084-080		CAP,E 0.22-50 SMG	C912	87-012-195-080		C-CAP,U 100P-50
C614	87-A12-084-080		CAP,E 0.22-50 SMG	C913	87-012-286-080		CAP, U 0.01-25
C615	87-012-172-080		CAPACITOR CHIP U 10P CH	C914	87-012-166-080		C-CAP,U 4P-50
C616	87-016-459-080		CAP,E 470-10 SMG	C915	87-012-174-080		C-CAP,CERA SS 12P
C617	87-016-459-080		CAP,E 470-10 SMG	C916	87-012-180-080		C-CAP,U 22P-50
C618	87-A12-091-080		CAP,E 10-50 SMG	C917	87-012-186-080		C-CAP,U 39P-50
C620	87-010-263-080		CAP, ELECT 100-10V	C918	87-A10-039-080		C-CAP,U 470P-50
C623	87-A12-084-080		CAP,E 0.22-50 SMG	C921	87-012-195-080		C-CAP,U 100P-50
C624	87-A12-084-080		CAP,E 0.22-50 SMG	C922	87-012-174-080		CAP CHIP CERA SS 12P
C630	87-016-669-080		C-CAP,S 0.1-25<LH,HS>	C959	87-010-831-080		C-CAP,U,0.1-16F
C630	87-A10-260-080		C-CAP,U 0.1-16 K B<HA>	C960	87-010-831-080		C-CAP,U,0.1-16F
C631	87-012-281-080		C-CAP,U 3900P-50 B	C961	87-012-167-080		C-CAP,U 5P-50
C632	87-012-281-080		C-CAP,U 3900P-50 B	C963	87-015-785-080		CHIP CAPACITOR, 0.1-25 Z F
C633	87-A11-070-080		C-CAP,U 0.033-16 K B	C971	87-A12-067-080		CAP,E 330-16 SMG
C634	87-A11-070-080		C-CAP,U 0.033-16 K B	C972	87-A12-090-080		CAP,E 4.7-50 SMG
C671	87-010-831-080		C-CAP,U 0.1-16 Z F<HS>	C973	87-012-286-080		CAP, U 0.01-25
C672	87-010-831-080		C-CAP,U 0.1-16 Z F<HS>	C974	87-012-286-080		CAP, U 0.01-25
C673	87-012-278-080		C-CAP,U 2200P-50 K B<HS>	C979	87-012-195-080		C-CAP,U 100P-50CH
C677	87-012-286-080		CAP, U 0.01-25	C981	87-A12-071-080		CAP,E 47-25 SMG
C771	87-A12-062-080		CAP,E 100-10 SMG	C982	87-010-831-080		C-CAP,U,0.1-16F
C772	87-012-286-080		CAP, U 0.01-25	C983	87-012-286-080		CAP, U 0.01-25
C782	87-012-286-080		CAP, U 0.01-25	C984	87-012-286-080		CAP, U 0.01-25
C783	87-012-286-080		CAP, U 0.01-25	C987	87-012-286-080		CAP, U 0.01-25
C784	87-012-286-080		CAP, U 0.01-25	C991	87-012-176-080		CAP 15P
C785	87-012-286-080		CAP, U 0.01-25	C992	87-012-176-080		CAP 15P
C786	87-012-286-080		CAP, U 0.01-25	C993	87-012-274-080		CHIP CAP,U 1000P-50B
C788	87-012-167-080		C-CAP,U 5P-50 CH	C995	87-012-274-080		CHIP CAP,U 1000P-50B
C789	87-016-118-080		C-CAP,U 0.022-25<HS>	C997	87-010-831-080		C-CAP,U,0.1-16F
C789	87-A12-052-080		C-CAP,S 0.033-25 J B<HA,LH>	C998	87-A12-071-080		CAP,E 47-25 SMG
C790	87-016-118-080		C-CAP,U 0.022-25<HS>	C999	87-A11-155-080		CAP,TC U 0.01-16 Z F
C790	87-A12-052-080		C-CAP,S 0.033-25 J B<HA,LH>	CF831	87-008-261-010		FILTER,CF SFE10.7MA5
C791	87-010-831-080		C-CAP,U 0.1-16F	CF832	87-008-261-010		FILTER, SFE10.7MA5-A
C792	87-012-286-080		CAP, U 0.01-25	CN301	87-A60-620-010		CONN,3P V 2MM JMT
C793	87-A12-090-080		CAP,E 4.7-50 SMG	CN351	87-A60-625-010		CONN,8P V 2MM JMT
C795	87-012-286-080		CAP, U 0.01-25	CN601	87-099-719-010		CONN,30P H BLK TYK-B(X)
C796	87-012-286-080		CAP, U 0.01-25	CN602	87-A60-131-010		CONN,6P V FE
C797	87-A12-091-080		CAP,E 10-50 SMG	CNA1	8A-NF8-653-010		CONN ASSY,9P TID-A(480)
C798	87-012-286-080		CAP, U 0.01-25	CNA301	86-ZM3-604-210		CONN ASSY,3P-PB
C799	87-010-265-080		CAP,E 33-16 M 11L SME	CNA351	86-ZM3-605-110		CONN ASSY,8P-RPB
C800	87-010-829-080		CAP, U 0.047-16	D902	87-A40-128-080		C-VARI-CAP,HVU202A

REF. NO.	PART NO.	KANRI NO.	DESCRIPTION	REF. NO.	PART NO.	KANRI NO.	DESCRIPTION
D903	87-A40-128-080		C-VARI-CAP,HVU202A	C407	87-010-405-040		CAP,E 10-50 M 11L SME<HS>
FC602	88-906-251-110		FF-CABLE,6P 1.25	C408	87-012-195-080		C-CAP,U 100P-50 J CH<HS>
J202	87-A60-488-010		JACK,DIA6.3 BLK ST W/SW KM16AT<HA, LH>	C409	87-010-265-040		CAP,E 33-16 M 11L SME<HS>
J202	87-A60-602-010		JACK,DIA6.3 BLK ST W/SW TC<HS>	C410	87-010-829-080		C-CAP,U 0.047-16 Z F<HS>
J203	87-A60-238-010		TERMINAL,SP 4P (MSC)	C413	87-010-177-080		C-CAP,U 820P-50 J SL<HS>
J602	87-A60-881-010		JACK,PIN 2P MSP 242V05 PBSN	C601	87-010-382-040		CAP,E 22-25 SME
J831	87-A60-202-010		TERMINAL,ANT 4P MSP-154V	C702	87-012-286-080		CAP, U 0.01-25
JR123	87-A10-596-080		C-CAP,S 100P-100<HA, LH>	C801	87-A10-804-080		C-CAP,S 0.1-25 J B
JR123	87-012-195-080		C-CAP,U 100P-50<HS>	C803	87-012-280-080		CAP, U 3300P-50
JR124	87-A10-596-080		C-CAP,S 100P-100<HA, LH>	C804	87-A10-592-080		C-CAP,S 0.015-50 J B
JR124	87-012-195-080		C-CAP,U 100P-50<HS>	C805	87-012-184-080		C-CAP,U 33P-50 CH
L201	87-A50-610-010		COIL,1UH K(MDEC)	C806	87-012-274-080		CHIP CAP,U 1000P-50B
L202	87-A50-610-010		COIL,1UH K(MDEC)	C807	87-012-274-080		CHIP CAP,U 1000P-50B
L451	87-007-342-010		COIL,OSC 85KHZ BIAS	C808	87-010-544-040		CAP,E 0.1-50 SME
L801	87-A50-608-010		COIL,FM DET-N(TOK)	C809	87-010-404-040		CAP,E 4.7-50 SME
L802	87-A91-551-010		FLTR,PCFJZH-450 L(TOK)	C810	87-016-114-080		C-CAP,U 0.01-25B
L811	87-005-847-080		COIL,2.2UH(CECS)	C811	87-A12-052-080		C-CAP,S 0.033-25 J B
L832	87-005-847-080		COIL,2.2UH(CECS)	C901	87-012-195-080		C-CAP,U 100P-50CH
L902	88-ZA1-602-110		COIL,FM-RF-U2 2G	C902	87-012-195-080		C-CAP,U 100P-50CH
L903	88-ZA1-601-010		COIL,FM-RF-U1 2G	C903	87-012-195-080		C-CAP,U 100P-50CH
L904	87-005-847-080		COIL,2.2UH(CECS)	C904	87-012-195-080		C-CAP,U 100P-50CH
L905	88-ZA1-624-010		COIL,FM IFT 7-6.2 (COILS)	C905	87-012-195-080		C-CAP,U 100P-50CH
L906	88-ZA1-603-010		COIL,FM-OSC-U 2G	C906	87-012-195-080		C-CAP,U 100P-50CH
L951	8A-NF8-667-010		COIL,AM PACK 4(TOK)	C907	87-012-195-080		C-CAP,U 100P-50CH
R129	87-A00-262-080		RES,M/F 0.15-2W J<HA, LH>	C908	87-012-195-080		C-CAP,U 100P-50CH
R129	87-A00-258-080		RES,M/F 0.22-1W J<HS>	C909	87-012-195-080		C-CAP,U 100P-50CH
R130	87-A00-262-080		RES,M/F 0.15-2W J<HA, LH>	C910	87-012-195-080		C-CAP,U 100P-50CH
R130	87-A00-258-080		RES,M/F 0.22-1W J<HS>	C911	87-012-274-080		CHIP CAP,U 1000P-50B
R131	87-A00-262-080		RES,M/F 0.15-2W J<HA, LH>	C912	87-010-831-080		C-CAP,U,0.1-16F
R131	87-A00-258-080		RES,M/F 0.22-1W J<HS>	C913	87-A10-189-040		CAP,E 220-10
R132	87-A00-262-080		RES,M/F 0.15-2W J<HA, LH>	C914	87-A10-189-040		CAP,E 220-10
R132	87-A00-258-080		RES,M/F 0.22-1W J<HS>	C915	87-010-831-080		C-CAP,U,0.1-16F
R243	87-A00-999-050		RES,180-1/2W J BLT2J<HA, HS>	C916	87-010-831-080		C-CAP,U,0.1-16F
R243	87-A01-001-050		RES,220-1/2W J BLT2J<LH>	C917	87-010-831-080		C-CAP,U,0.1-16F
R244	87-A00-999-050		RES,180-1/2W J BLT2J<HA, HS>	C919	87-012-286-080		CAP, U 0.01-25
R244	87-A01-001-050		RES,220-1/2W J BLT2J<LH>	C920	87-010-829-080		CAP, U 0.047-16
R245	87-A00-999-050		RES,180-1/2W J BLT2J<HA, HS>	C921	87-012-282-080		CAP, U 4700P-50
R245	87-A00-441-050		RES,270-1/2W J RP<LH>	C951	87-012-172-080		CAPACITOR CHIP U 10P CH
R246	87-A00-999-050		RES,180-1/2W J BLT2J<HA, HS>	C952	87-010-854-080		C-CAP,S 560PCH
R246	87-A00-441-050		RES,270-1/2W J RP<LH>	C953	87-012-349-080		C-CAP,S 1000P-50 CH
R790	87-012-286-080		CAP, U 0.01-25	C961	87-010-378-040		CAP,E 10-16
R991	87-012-195-080		C-CAP,U 100P-50CH	C962	87-012-336-080		CAP, CHIP U 330P SL
R993	87-012-195-080		C-CAP,U 100P-50CH	C963	87-010-831-080		C-CAP,U,0.1-16F
R995	87-012-195-080		C-CAP,U 100P-50CH	CN104	87-A60-057-010		CONN,11P V 9604S-11C
SFR451	87-024-435-080		SFR 33K H RH063EC	CN701	87-099-720-010		CONN,30P TYK-B(P)
SFR452	87-024-435-080		SFR 33K H RH063EC	CN731	87-099-196-010		CONN,8P 6216 V
TH101	87-A91-042-080		C-THMS,100K 55001	EMI401	87-008-372-080		FLTR,EMI BL01 RN1<HS>
TH102	87-A91-042-080		C-THMS,100K 55001	FC731	88-908-301-110		FF-CABLE,8P 1.25
WH1	87-A90-510-010		HLDL,WIRE 2.5-9P	FFC104	88-911-101-110		FF-CABLE,11P 1.25
X992	87-A70-306-010		VIB,XTAL 4.500MHZ CSA-309ST	FL901	8B-NFY-605-010		FL,HNA-08LS02
FRONT C.B				J401	87-A61-243-010		JACK,6.3 BLK MONO W/SW V MSC<HS>
				L951	87-A50-655-010		COIL,CLK 4.19MHZ (TOKO)7KLY
				LED209	87-A41-062-040		LED,LTL-1CHEE-012A RED
C108	87-010-785-080		C-CAP,U 0.015-25BK	S321	87-A90-164-080		SW,TACT SKQAB(N)
C153	87-010-787-080		CAP, U 0.022-25	S322	87-A90-164-080		SW,TACT SKQAB(N)
C154	87-010-246-040		CAP,E 47-35 SME				
C155	87-010-404-040		CAP,E 4.7-50 SME	S323	87-A90-164-080		SW,TACT SKQAB(N)
C156	87-010-404-040		CAP,E 4.7-50 SME	S324	87-A90-164-080		SW,TACT SKQAB(N)
				S325	87-A90-164-080		SW,TACT SKQAB(N)
C301	87-012-278-080		C-CAP,U 2200P-50 B	S326	87-A90-164-080		SW,TACT SKQAB(N)
C351	87-A10-353-080		C-CAP,U 0.22-10KB	S327	87-A90-164-080		SW,TACT SKQAB(N)
C361	87-012-274-080		CHIP CAP,U 1000P-50B				
C362	87-012-274-080		CHIP CAP,U 1000P-50B	S328	87-A90-164-080		SW,TACT SKQAB(N)
C371	87-012-274-080		CHIP CAP,U 1000P-50B	S329	87-A90-164-080		SW,TACT SKQAB(N)
				S330	87-A90-164-080		SW,TACT SKQAB(N)
C372	87-012-274-080		CHIP CAP,U 1000P-50B	S331	87-A90-164-080		SW,TACT SKQAB(N)
C401	87-012-282-080		C-CAP,U 4700P-50 K B<HS>	S332	87-A90-164-080		SW,TACT SKQAB(N)
C402	87-010-112-040		CAP,E 100-16 M 11L SME<HS>				
C403	87-010-545-040		CAP,E 0.22-50 M 11L SME<HS>	S333	87-A90-164-080		SW,TACT SKQAB(N)
C404	87-012-191-080		C-CAP,U 68P-50 J CH<HS>	S334	87-A90-164-080		SW,TACT SKQAB(N)
				S341	87-A90-164-080		SW,TACT SKQAB(N)
C405	87-010-544-040		CAP,E 0.1-50 M 11L SME<HS>	S342	87-A90-164-080		SW,TACT SKQAB(N)
C406	87-010-544-040		CAP,E 0.1-50 M 11L SME<HS>	S343	87-A90-164-080		SW,TACT SKQAB(N)

REF. NO.	PART NO.	KANRI NO.	DESCRIPTION	REF. NO.	PART NO.	KANRI NO.	DESCRIPTION
S344	87-A90-164-080		SW, TACT SKQAB (N)				
S345	87-A90-164-080		SW, TACT SKQAB (N)				
S346	87-A90-164-080		SW, TACT SKQAB (N)				
S347	87-A90-164-080		SW, TACT SKQAB (N)				
S348	87-A90-164-080		SW, TACT SKQAB (N)				
S349	87-A90-164-080		SW, TACT SKQAB (N)				
S361	87-A91-633-010		SW, RTRY XRE012103PVB25FINA 1-2				
S371	87-A91-632-010		SW, RTRY XRE012103PVB25FINB 1-2				
VR401	87-NB7-602-010		VR, RTRY 10KAX1 1 V<HS>				
PT C.B							
	CN1	87-A61-110-010	CONN, 9P V TID-A				
△	PT1	8B-NF9-615-010	PT, BNF-9 LH<LH>				
△	PT1	8B-NFY-693-010	PT, BNF-Y LH-HI<HA>				
△	PT1	8B-NF9-613-010	PT, BNF-9 HR<HS>				
△	PT2	8B-NF9-663-010	PT, SUB BNF H (TAM) <HS>				
△	PT2	8B-MA6-673-010	PT, SUB BMA H (VRK) <HA, LH>				
△	RY1	87-A91-339-010	RELAY, AC DC12V G5PA-2				
△	S1	87-A90-165-010	SW, SL 1-2-3 SWS2301<HA, LH>				
△	T1	87-A60-317-010	TERMINAL, 1P MSC				
△	T2	87-A60-317-010	TERMINAL, 1P MSC				
				DECK C.B			
				CN1	87-099-753-010		CONN, 11P H 9604
				SFR1	87-024-581-010		SFR, 3.3K H KVSP637A
				SOL1	82-ZM3-634-110		SOL ASSY, 27 OM<HS>
				SOL1	82-ZM3-627-010		SOL ASSY, 27 SO<HA, LH>
				SOL2	82-ZM3-634-110		SOL ASSY, 27 OM<HS>
				SOL2	82-ZM3-627-010		SOL ASSY, 27 SO<HA, LH>
				SW1	87-A90-673-010		SW, MICRO ESE11SH1C
				SW2	87-A90-673-010		SW, MICRO ESE11SH1C
				SW3	87-A90-673-010		SW, MICRO ESE11SH1C
				SW4	87-A90-673-010		SW, MICRO ESE11SH1C
				SW5	87-A90-673-010		SW, MICRO ESE11SH1C
				W1	82-ZM3-601-010		RBN-CORD, 4P-75

TRANSISTOR ILLUSTRATION

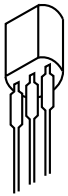

E C B

KTC3198



E C B

STC250

A MAIN C.B

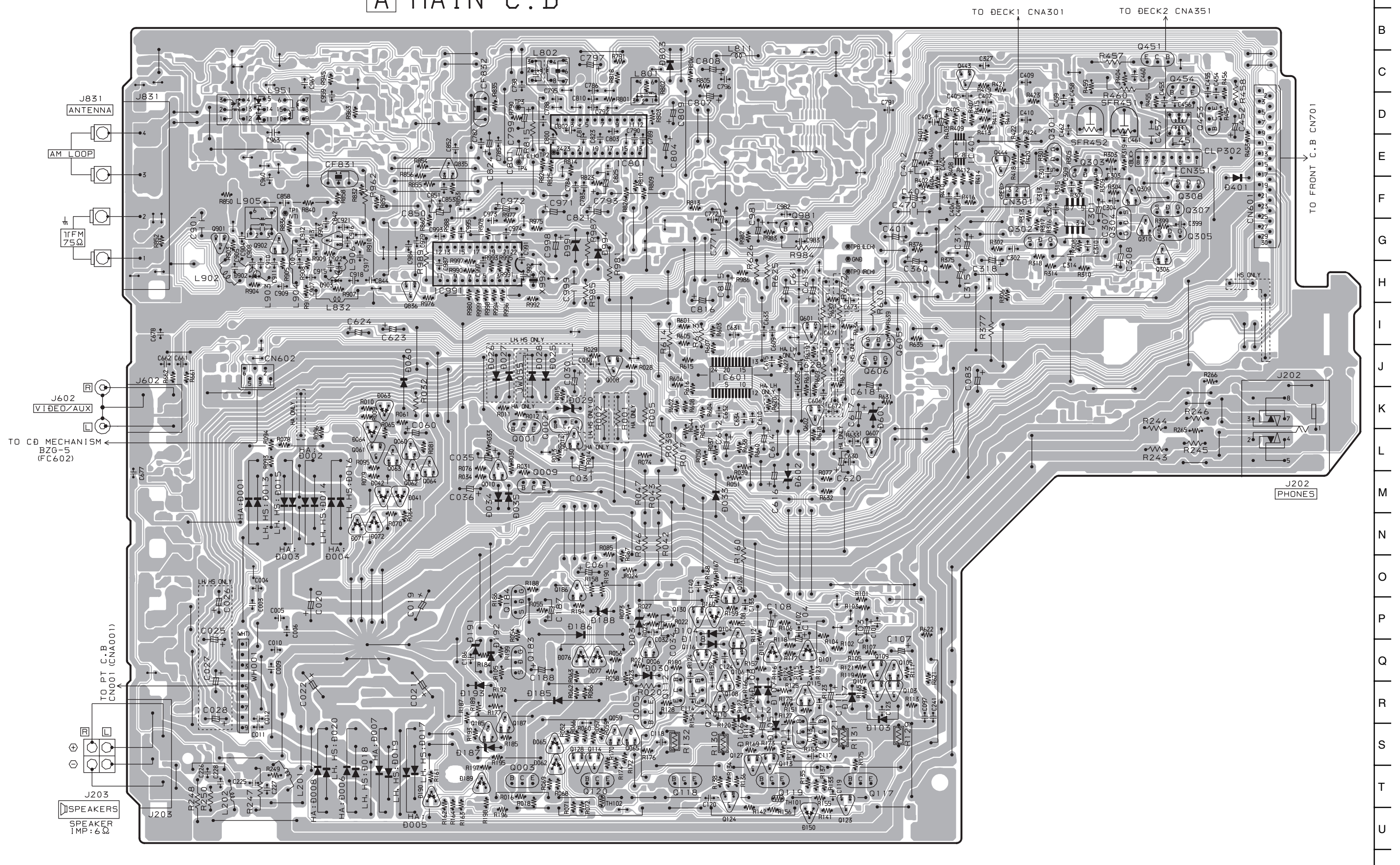

SCHEMATIC DIAGRAM - 1 (MAIN 1/2)

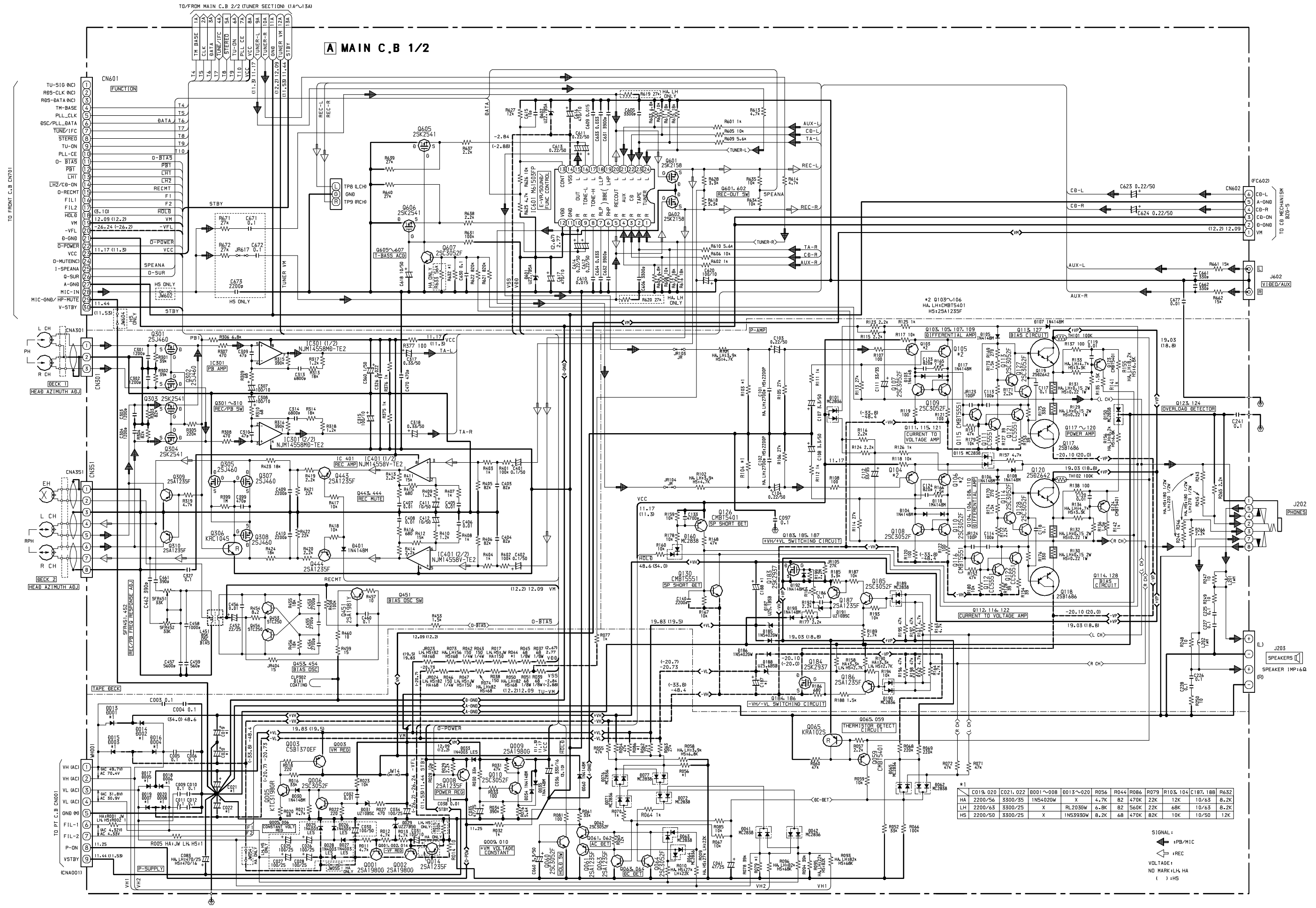

SCHEMATIC DIAGRAM-2 (MAIN 2/2 : TUNER)

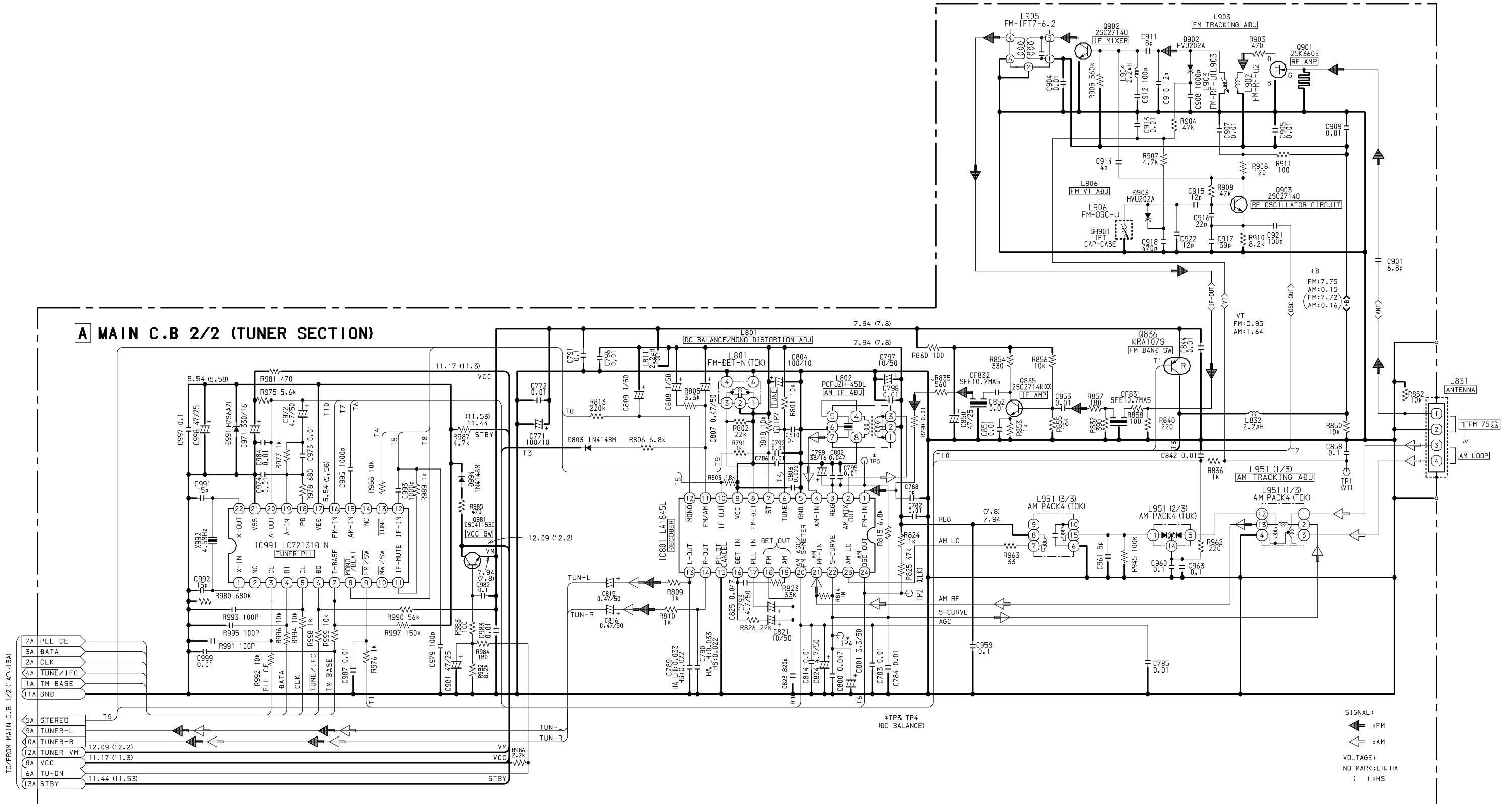

B FRONT C.B

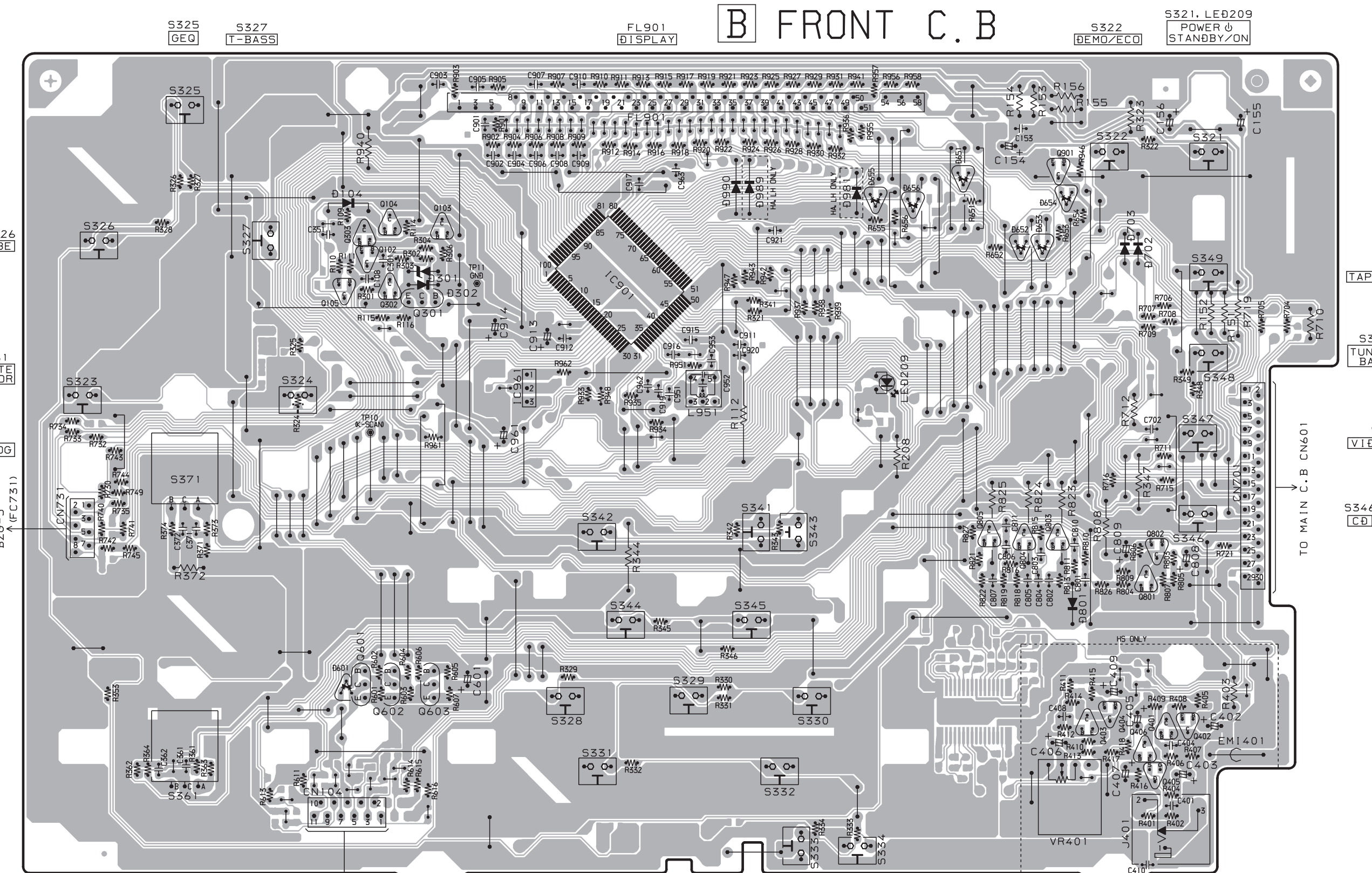

TO MAIN C.B CN601

TO DECK C.B CN1 (FFC104)

VR401 MIC MIXING J401 MIC
H5 ONLY

S328 3 S329 2 S330 1
DISC DIRECT PLAY

S331 OPEN/CLOSE S332 DISC CHANGE

A B C D E F G H I J K L M N O P Q R S T U

SCHEMATIC DIAGRAM - 3 (FRONT / DECK)

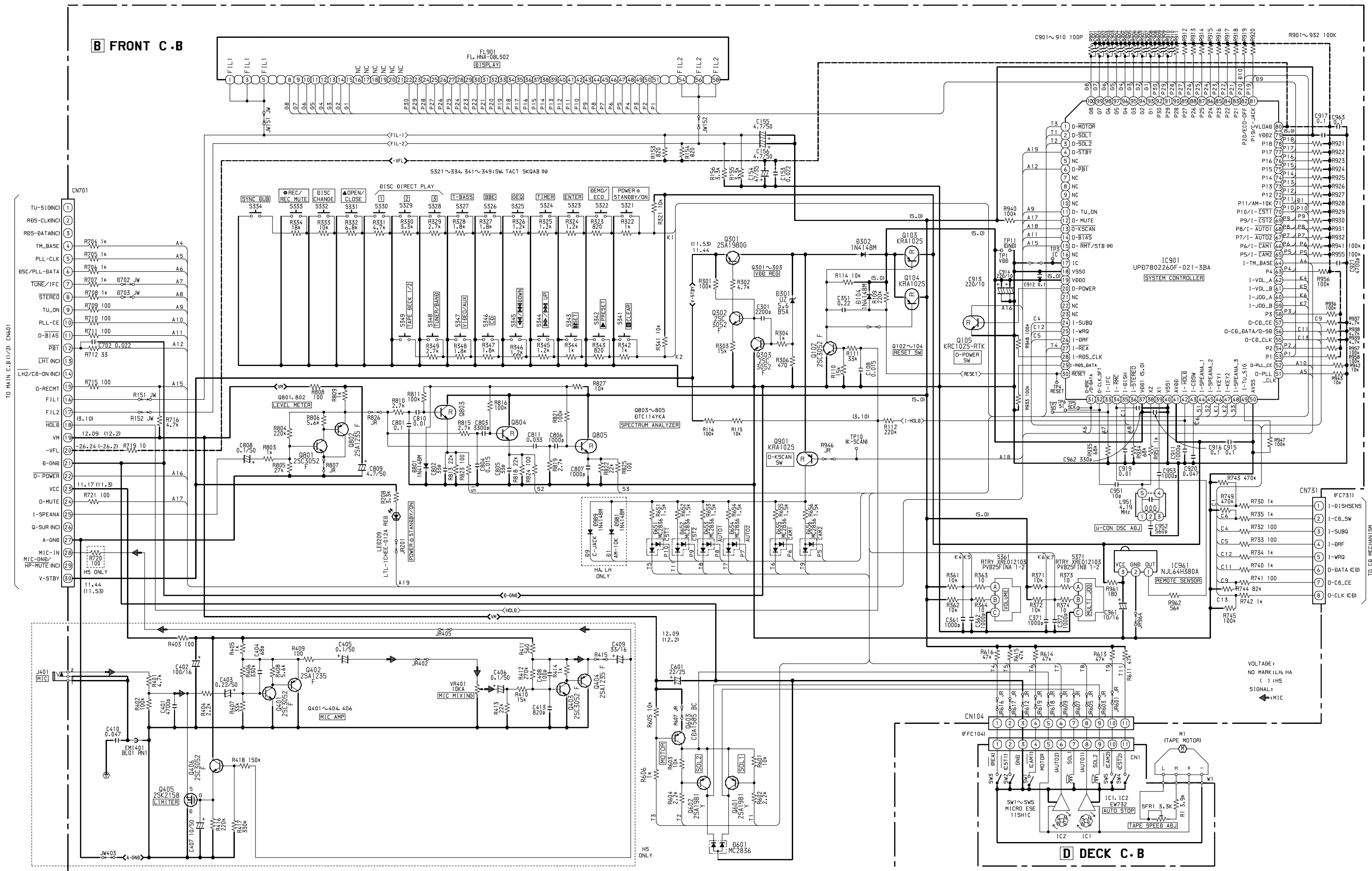

WIRING - 3 (HA : PT)

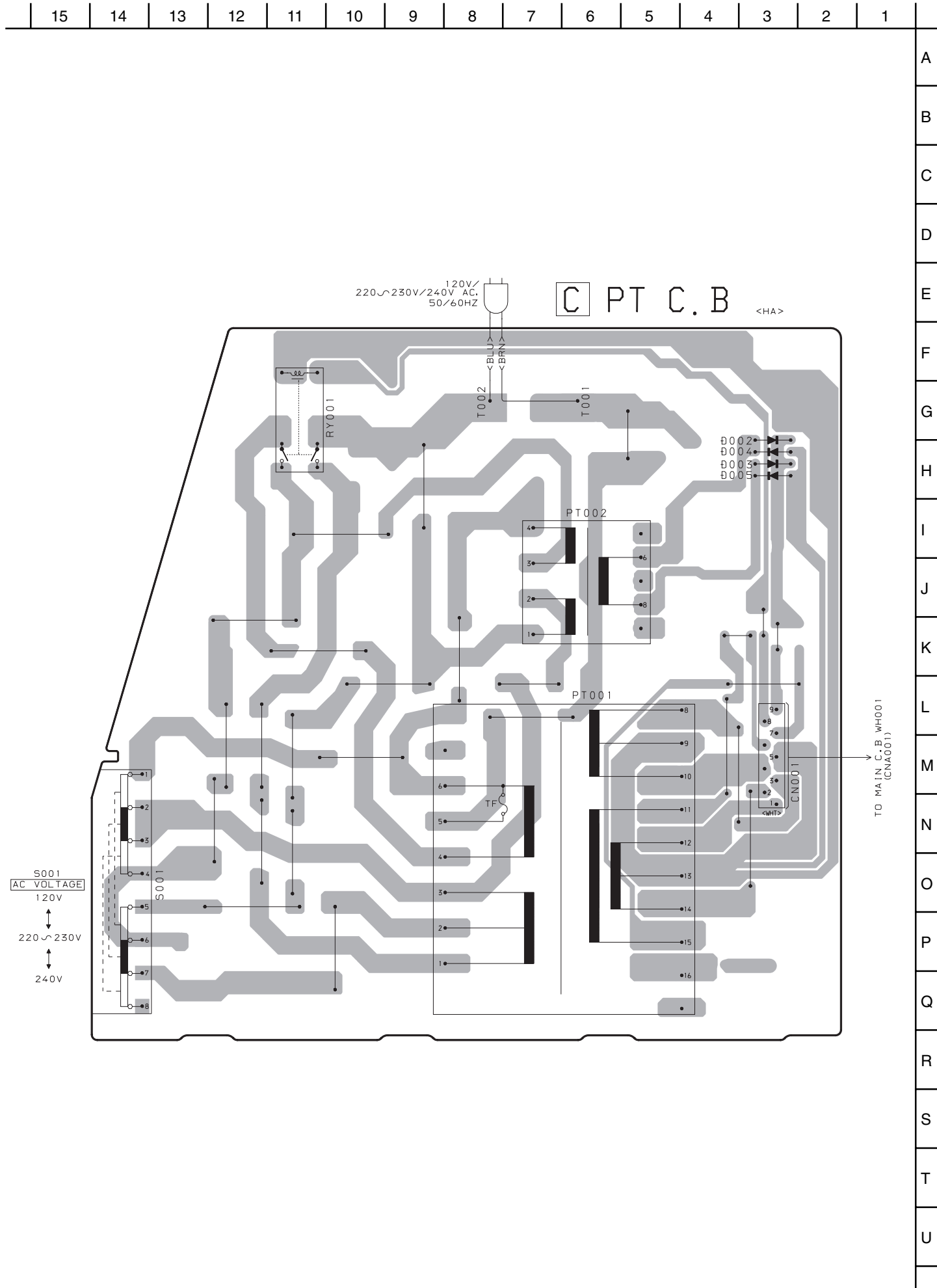

SCHEMATIC DIAGRAM-4 (HA:PT)

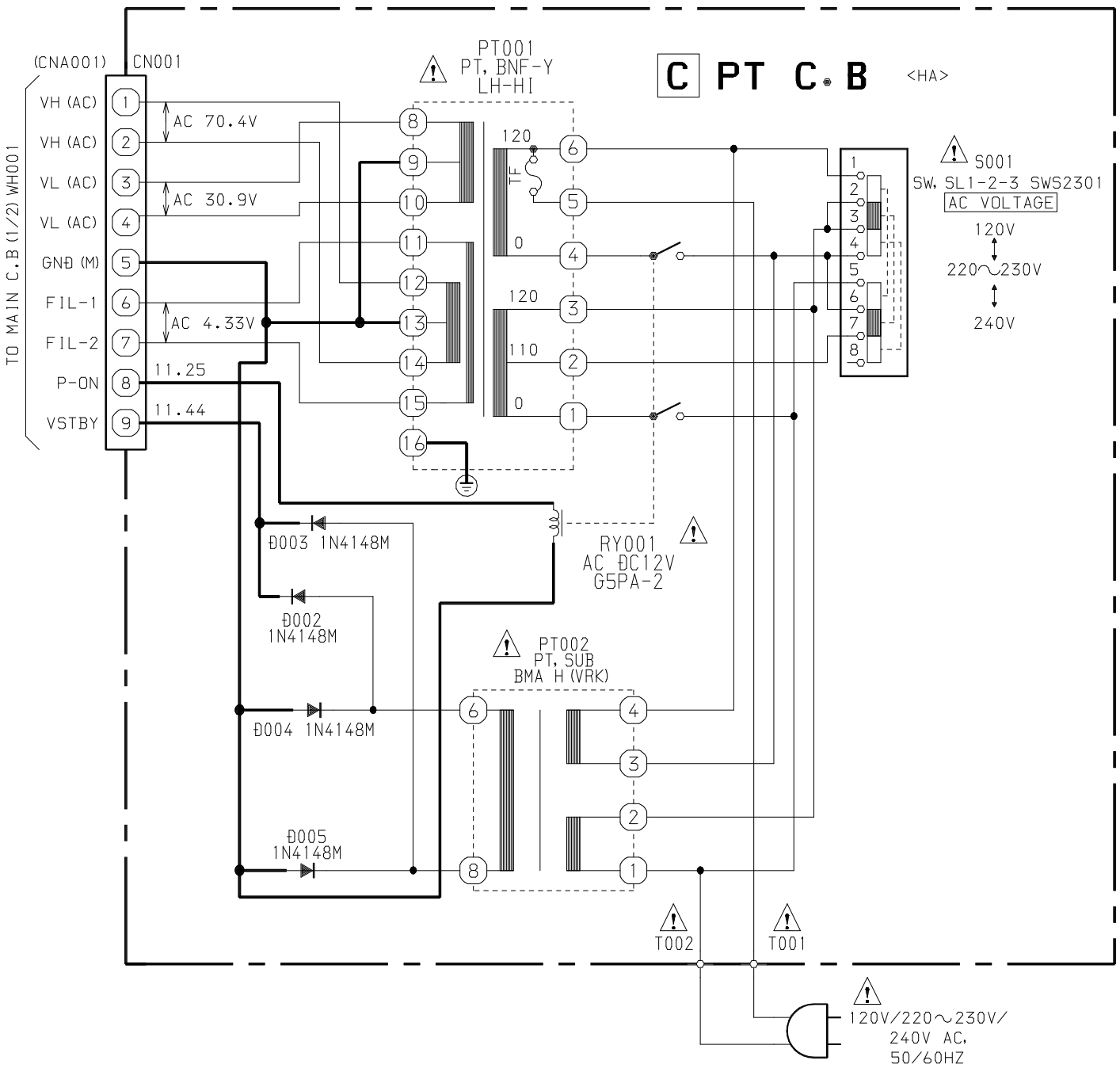

WIRING - 4 (LH : PT)

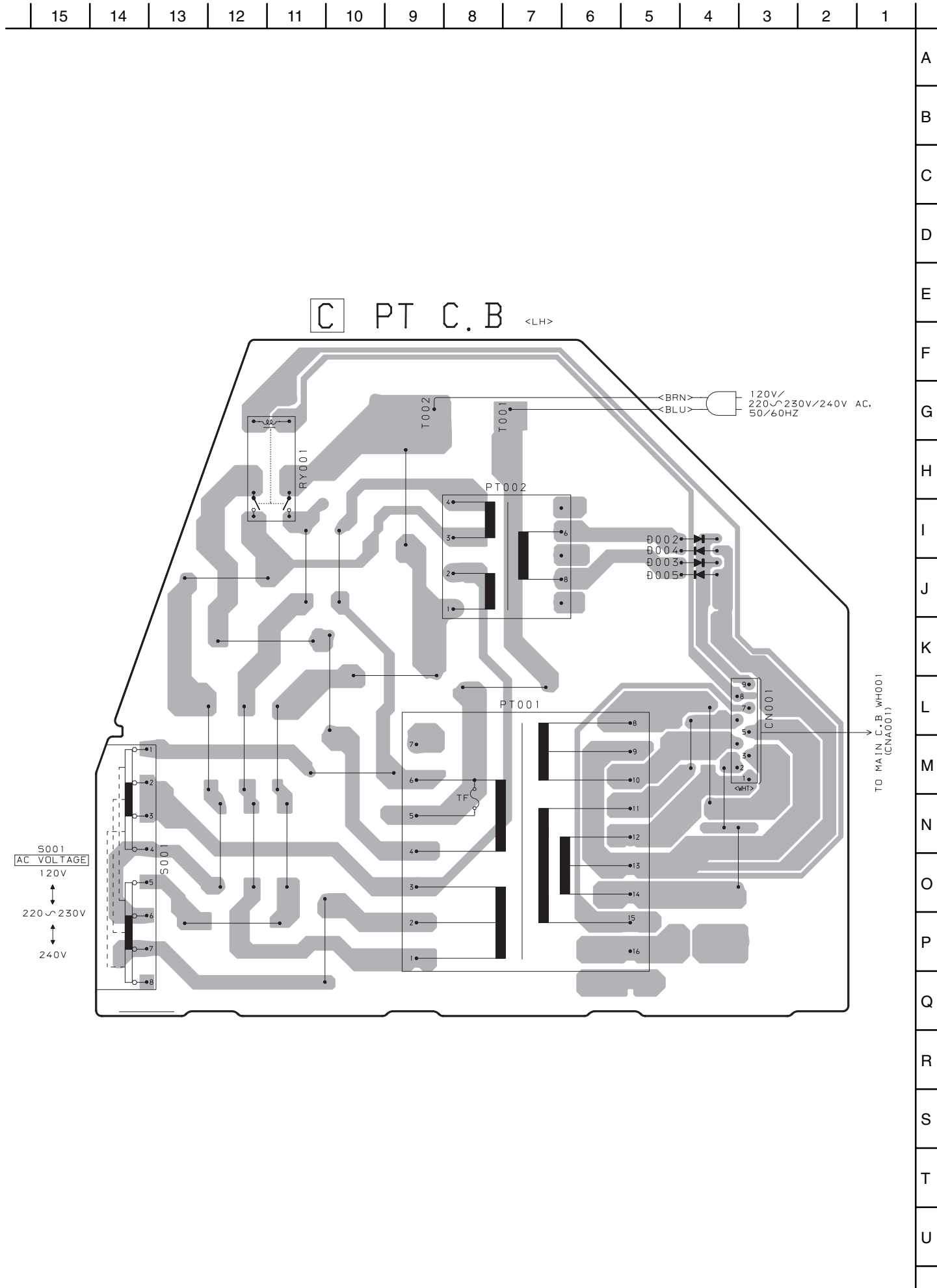

SCHEMATIC DIAGRAM-5 (LH:PT)

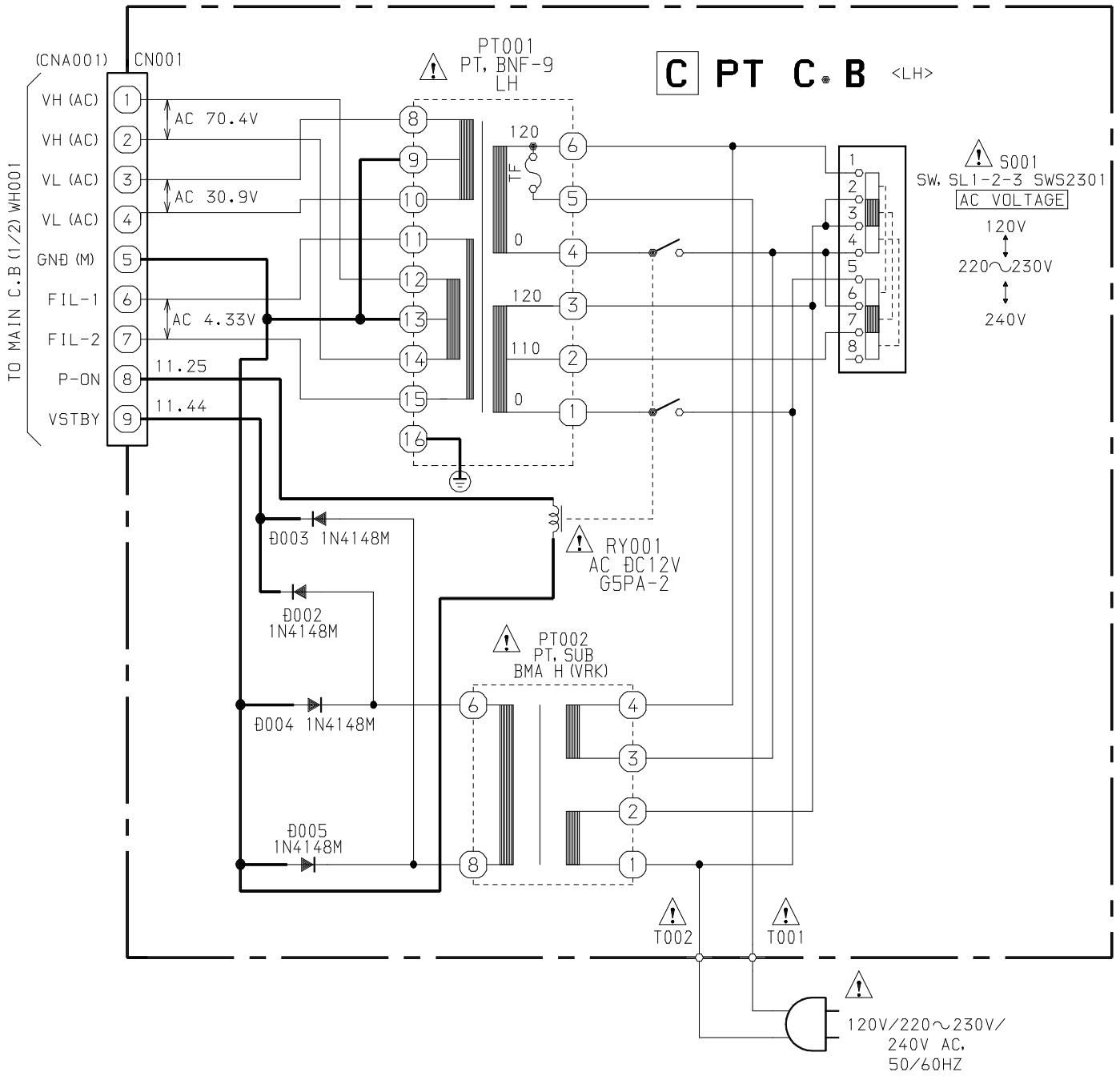

WIRING - 5 (HS : PT)

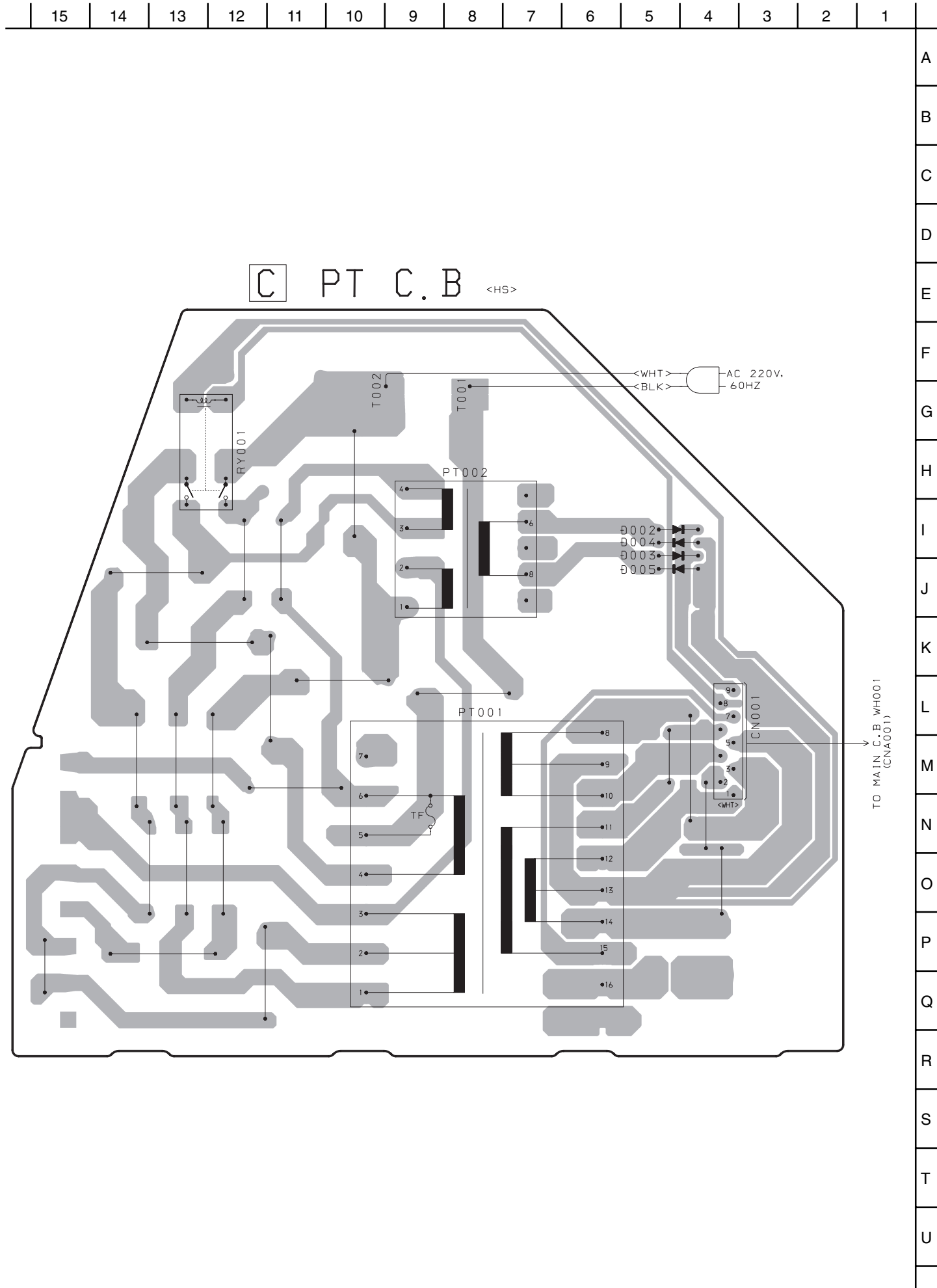

SCHEMATIC DIAGRAM-6 (HS:PT)

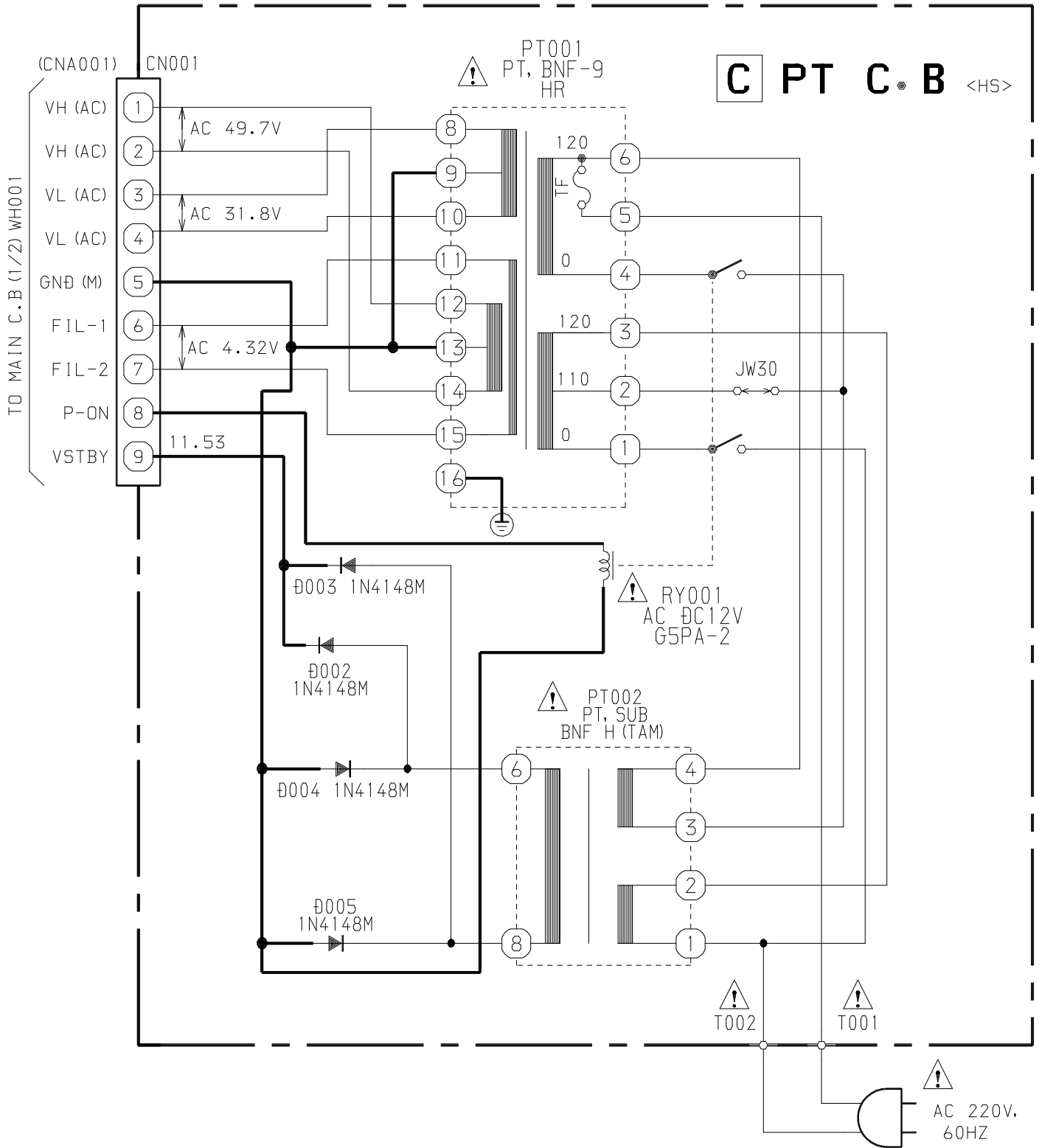

D DECK C.B

TO FRONT C.B. CN104

(FFC104)

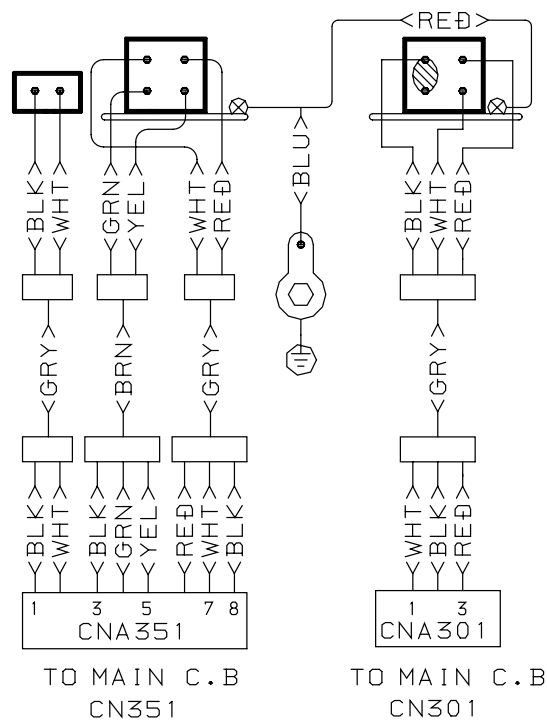
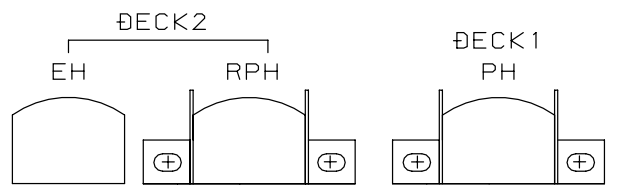
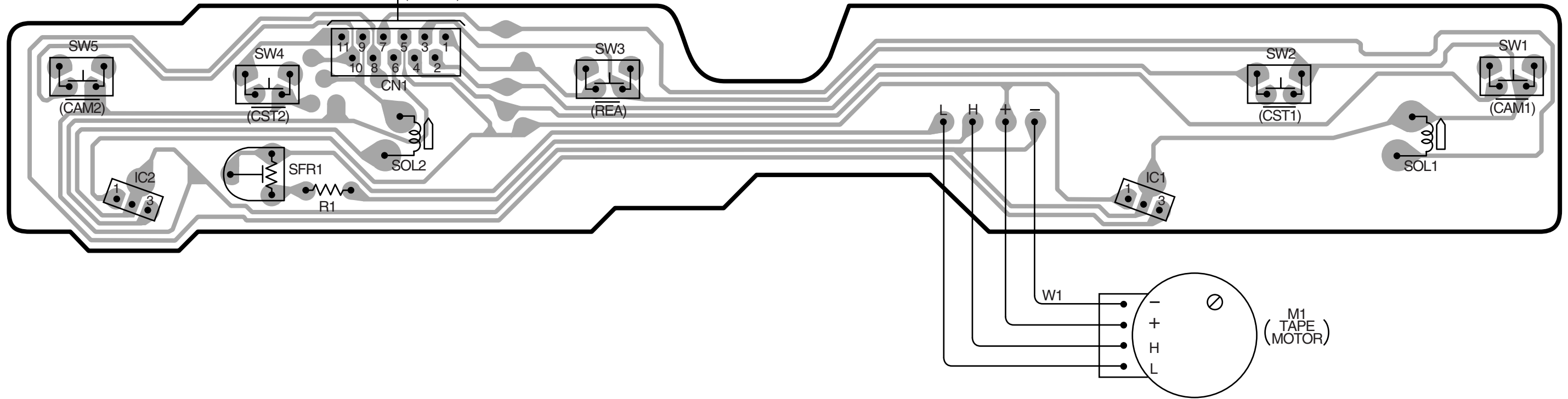

A
B
C
D
E
F
G
H
I
J
K
L
M
N
O
P
Q
R
S
T
U

ADJUSTMENT (TUNER)

< TUNER SECTION >

1. Clock Frequency Check<HS,HA>

Settings : • Test point : TP2 (CLK)

Method : Set to AM 1602kHz and check that the test point is
2052kHz \pm 45Hz.

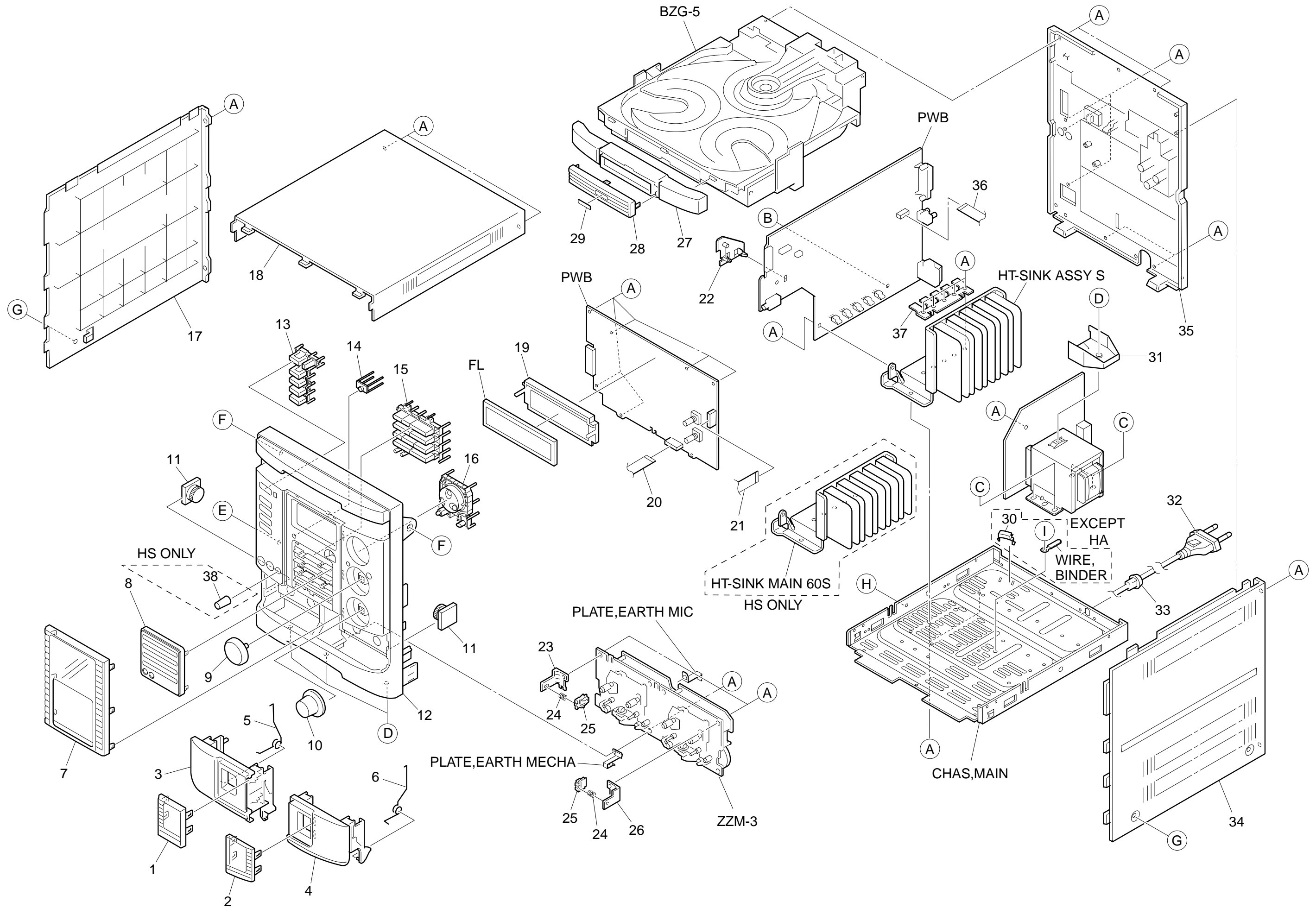

MECHANICAL PARTS LIST 1 / 1

REF. NO.	PART NO.	KANRI NO.	DESCRIPTION	REF. NO.	PART NO.	KANRI NO.	DESCRIPTION
1	8B-NFY-008-010		WINDOW, CASS 2	28	8B-NFY-017-210		PANEL, CD
2	8B-NFY-007-010		WINDOW, CASS 1	29	87-CE3-023-010		BADGE, AIWA 30N SILV
3	8B-NFY-003-110		BOX, CASS 1	30	87-NF4-221-010		HLLDR, CABLE<HS, LH>
4	8B-NFY-004-110		BOX, CASS 2	31	8A-NF7-225-010		HLLDR, PWB PT 85S<HA>
5	8A-NF8-281-010		SPR-T, EJECT 1	31	8A-NF9-211-010		HLLDR, PWB PT HI<HS, LH>
6	8A-NF8-282-010		SPR-T, EJECT 2	△	32	87-A80-105-010	AC CORD ASSY, AZ<HA>
7	8B-NFY-005-010		WINDOW, DISP U	△	32	87-A80-157-010	AC CORD ASSY, E BLK CC<LH>
8	8B-NFY-023-010		PANEL, FR HR<HS>	△	32	87-A80-155-010	AC CORD ASSY, HS TS<HS>
8	8B-NFY-063-010		PANEL, FR LH 319<LH>	33	87-085-185-010		BUSHING, AC CORD (E)
8	8B-NFY-064-010		PANEL, FR LH 519<HA>	34	8B-NF9-025-010		PANEL, RIGHT
9	8B-NFY-014-010		KNOB, RTRY JOG	35	8B-NF9-080-010		CABI, REAR HSSFD<HS>
10	8B-NFY-015-010		KNOB, RTRY VOL	35	8B-NF9-002-010		CABI, REAR LH W/O SPC<HA, LH>
11	8Z-NF6-210-010		DMPR, 150 N	36	88-906-251-110		FF-CABLE, 6P 1.25 (RVS-FACE)
12	8B-NFY-020-010		CABI, FR HR<HS>	37	8B-NF9-211-110		HLLDR, TR S
12	8B-NFY-067-010		CABI, FR LH D.I.N.A<HA, LH>	38	8B-NFY-016-010		KNOB, RTRY MIC<HS>
13	8B-NFY-012-110		KEY, FUN	A	87-067-703-010		TAPPING SCREW, BVT2+3-10
14	8B-NFY-036-010		REFLECTOR, ECO	B	87-NF4-224-010		S-SCREW, IT3B+3-8 CU
15	8B-NFY-010-010		KEY, OPE 1W	C	87-078-200-010		S-SCREW, ITC+4-8 R
16	8B-NFY-013-010		KEY, GEQ	D	87-067-689-010		TAPPING SCREW, BVTT+3-8
17	8B-NF9-026-010		PANEL, LEFT	E	87-723-096-410		QT2+3-10W/O SLOT BL
18	8B-NF9-027-010		PANEL, TOP	F	87-721-097-410		QT2+3-12 GLD
19	8B-NFY-201-110		GUIDE, FL 100-40 BNFY	G	87-067-641-010		UTT2+3-8 (W/O SLOT) BL
20	88-911-101-110		FF-CABLE, 11P 1.25	H	87-721-096-410		QT2+3-10 GLD
21	88-908-301-110		FF-CABLE, 8P 1.25	I	87-067-584-010		TAPPING SCREW, BVT2+3-6<HS, LH>
22	8A-NF8-206-010		HLLDR, PWB M				
23	87-NF4-216-010		HLLDR, LOCK 1				
24	86-NF9-224-010		SPR-C, LOCK				
25	82-NF5-229-010		PLATE, LOCK				
26	87-NF4-217-110		HLLDR, LOCK 2				
27	8B-NFY-002-010		PANEL, TRAY				

COLOR NAME TABLE

Basic color symbol	Color	Basic color symbol	Color	Basic color symbol	Color
B	Black	C	Cream	D	Orange
G	Green	H	Gray	L	Blue
LT	Transparent Blue	N	Gold	P	Pink
R	Red	S	Silver	ST	Titan Silver
T	Brown	V	Violet	W	White
WT	Transparent White	Y	Yellow	YT	Transparent Yellow
LM	Metallic Blue	LL	Light Blue	GT	Transparent Green
LD	Dark Blue	DT	Transparent Orange	GM	Metallic Green
YM	Metallic Yellow	DM	Metallic Orange	PT	Transparent Pink
LA	Aqua Blue	GL	Light Green	HT	Transparent Gray

SPEAKER PARTS LIST <SX-NSZ319 (YLSCM) / SX-NSZ312 (YSC)>

REF. NO.	PART NO.	KANRI NO.	DESCRIPTION
1	8B-NSY-001-010		PANEL, FR
2	8B-NSY-003-010		PANEL, TW
3	8B-NSY-009-010		PROTECTOR, TW
4	8B-NSY-010-010		SPKR, CERAMIC ASSY<YSC>
5	8B-NSY-005-010		GRILLE, FRAME ASSY
6	8B-NSY-602-010		SPKR, W 140/30<YLSCM>
6	8B-NSY-604-010		SPKR, W 140/25<YSC>
7	8B-NSK-604-010		SPKR, T 60<YLSCM>
7	8B-NSY-606-010		SPKR, TW 60L<YSC>
8	8B-NSY-610-010		CORD, SPKR
9	8B-NSY-025-010		FOOT<YLSCM>

SPEAKER PARTS LIST <SX-NSZ702 (YLSC)>

REF. NO.	PART NO.	KANRI NO.	DESCRIPTION
1	8B-NSJ-001-010		PANEL, FR
2	8B-NSJ-003-010		PANEL, DUCT
3	8B-NSJ-004-010		PROTECTOR
4	8B-NSJ-606-010		SPKR, W 160 35/4
5	8B-NSJ-604-010		SPKR, TW 60
6	8B-NSJ-612-010		CORD, SPKR

ACCESSORIES / PACKAGE LIST

REF. NO.	PART NO.	KANRI NO.	DESCRIPTION
1	8B-NFY-919-010		IB, LH (P) CCE-SZ319<LH>
1	8B-NFY-920-010		IB, HA (S) NEA-SZ519<HA>
1	8B-NFY-909-010		IB, HS (K) IN<HS>
2	87-006-268-010		ANT, LOOP AM
3	87-043-115-010		FEEDER-ANT, FM
4	8Z-NF9-702-010		RC UNIT, ZAS02

アイワ株式会社 〒110-8710 東京都台東区池之端1-2-11 ☎03(3827)3111 (代表)
AIWA CO.,LTD. 2-11, IKENOHATA 1-CHOME, TAITO-KU, TOKYO 110, JAPAN TEL:03 (3827) 3111