

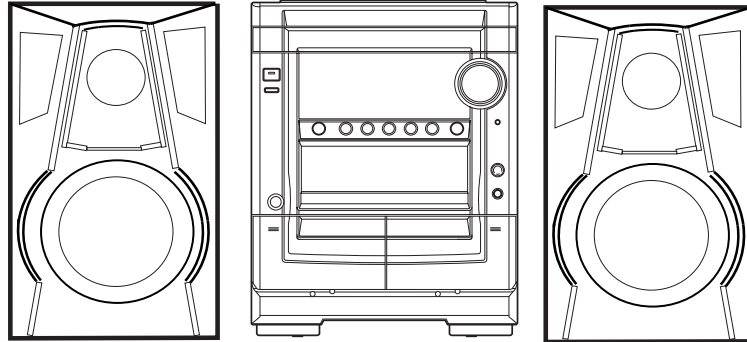

NSX-AJ700 U

NSX-SZ700 LH

NSX-SZ705 LH



SERVICE MANUAL

COMPACT DISC
STEREO SYSTEM

BASIC TAPE MECHANISM : 2ZM-3MK2 PR9NM
ZM-3 PR1NM
BASIC CD MECHANISM : BZG-5 ZD3N1M

SYSTEM	CD CASSEIVER	TAPE MECHANISM	SPEAKER	REMOTE CONTROLLER
NSX-AJ700	CX-NAJ700	ZZM-3 PR1NM	SX-NAJ702	RC-BAS02
NSX-SZ700	CX-NSZ700	2ZM-3MK2 PR9NM	SX-WNSZ703	
NSX-SZ705	CX-NSZ705	2ZM-3MK2 PR9NM	SX-NSZ705	

- This Service Manual is the "Revision Publishing" and replaces "Simple Manual" NSX-AJ700 (U) / NSX-SZ700 (LH) / NSX-SZ705 (LH), (S/M Code No. 09-012-441-7T1).
- If requiring information about the CD mechanism, see Service Manual of BZG-5, (S/M Code No. 09-00C-353-3N2).

aiwa

S/M Code No. 09-013-441-7R1

REVISION
DATA

SPECIFICATIONS

<FM tuner section>

Tuning range	87.5 MHz to 108 MHz
Usable sensitivity (IHF)	13.2 dBf
Antenna terminals	75 ohms (unbalanced)

<AM tuner section>

Tuning range	530 kHz to 1710 kHz (10 kHz step) 531 kHz to 1602 kHz (9 kHz step)
Usable sensitivity	350 μ V/m
Antenna	Loop antenna

<Amplifier section>

Power output	U : 100 W + 100 W (50 Hz to 20 kHz, T.H.D. less than 1 %, 6 ohms) 120 W + 120 W (1 kHz, T.H.D. less than 10 %, 6 ohms) LH : Rated 112 W + 112 W (1 kHz, T.H.D. 1 %, 6 ohms) Reference : 140 W + 140 W (6 ohms, T.H.D. 10 %, 1 kHz)
Total harmonic distortion	U : 0.08 % (10 W, 1 kHz, 6 ohms, DIN AUDIO) LH : 0.08 % (70 W, 1 kHz, 6 ohms, DIN AUDIO)
Inputs	VIDEO / AUX: 700 mV LH only : MIC : 1.7 mV (10 kohms)
Outputs	SPEAKERS : accept speakers of 6 ohms or more PHONES : accepts headphones of 32 ohms or more

<Compact disc player section>

Laser	Semiconductor laser ($\lambda = 780$ nm)
D/A converter	1 bit dual
Signal-to-noise ratio	85 dB (1 kHz, 0 dB)
Harmonic distortion	0.05 % (1 kHz, 0 dB)

<Cassette deck section>

Track format	4 tracks, 2 channels stereo
Frequency response	50 Hz – 15000 Hz
Recording system	AC bias
Heads	Deck 1 : Playback x 1 Deck 2 : Recording / Playback x 1, erase x 1

<Speaker system SX-NAJ702 (U)>

Speaker system	2 way, bass reflex (magnetic shielded)
Speaker units	Woofer : 160 mm (6 ³ / ₈ in.) cone Tweeter : 60 mm (2 ³ / ₈ in.) cone
Impedance	6 ohms
Dimensions (W x H x D)	230 x 324 x 253 mm (9 ¹ / ₈ x 12 ⁷ / ₈ x 10 in.)
Weight	4.6 kg (10 lbs 2 oz.)

<Speaker system SX-WNSZ703 (700LH)>

Speaker system	3 way, built-in subwoofer (magnetic shielded type)
Speaker units	Subwoofer : 160 mm cone type Full range : 100 mm cone type Super tweeter : 20 mm ceramic type
Impedance	6 ohms
Dimensions (W x H x D)	230 x 324 x 257 mm
Weight	4.8 kg

<Speaker system SX-NSZ705 (705LH)>

Speaker system	2 way, bass reflex (magnetic shielded)
Speaker units	Woofer : 160 mm cone Tweeter : 60 mm cone
Impedance	6 ohms
Dimensions (W x H x D)	230 x 324 x 235 mm
Weight	4.6 kg

<General>

Power requirements	U : 120 V AC, 60 Hz LH : 120 V / 220 – 230 V / 240 V AC, (switchable), 50 / 60 Hz
Power consumption	U : 100 W LH : 130 W
Power consumption in standby mode	With ECO mode on : 0.6 W With ECO mode off : 23 W
Dimensions of main unit (W x H x D)	260 x 326 x 345 mm (10 ¹ / ₄ x 12 ⁷ / ₈ x 13 ⁵ / ₈ in.)
Weight of main unit	U : 7.5 kg (16 lbs 9 oz.) LH : 8.4 kg

• Design and specifications are subject to change without notice.

• The word "BBE" and the "BBE symbol" are trademarks of BBE Sound, Inc.
Under license from BBE Sound, Inc.

PROTECTION OF EYES FROM LASER BEAM DURING SERVICING

This set employs laser. Therefore, be sure to follow carefully the instructions below when servicing.

WARNING!!

WHEN SERVICING, DO NOT APPROACH THE LASER EXIT WITH THE EYE TOO CLOSELY. IN CASE IT IS NECESSARY TO CONFIRM LASER BEAM EMISSION. BE SURE TO OBSERVE FROM A DISTANCE OF MORE THAN 30cm FROM THE SURFACE OF THE OBJECTIVE LENS ON THE OPTICAL PICK-UP BLOCK.



- Caution: Invisible laser radiation when open and interlocks defeated avoid exposure to beam.
- Advarsel: Usynlig laserstråling ved åbning, når sikkerhedsafbrydere er ude af funktion. Undgå udsættelse for stråling.

VAROITUS!

Laitteen Käyttäminen muulla kuin tässä käyttöohjeessa mainitulla tavalla saattaa altistaa käyttäjän turvallisuusluokan 1 ylittävälle näkymättömälle lasersäteilylle.

WARNING!

Om apparaten används på annat sätt än vad som specificeras i denna bruksanvisning, kan användaren utsättas för osynlig laserstrålning, som överskrider gränsen för laserklass 1.

CAUTION

Use of controls or adjustments or performance of procedures other than those specified herein may result in hazardous radiation exposure.

ATTENTION

L'utilisation de commandes, réglages ou procédures autres que ceux spécifiés peut entraîner une dangereuse exposition aux radiations.

ADVARSEL

Usynlig laserstråling ved åbning, når sikkerhedsafbrydere er ude af funktion. Undgå udsættelse for stråling.

This Compact Disc player is classified as a CLASS 1 LASER product.

The CLASS 1 LASER PRODUCT label is located on the rear exterior.

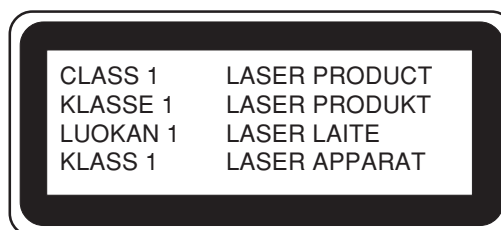

Precaution to replace Optical block

(KSS-213F)

Body or clothes electrostatic potential could ruin laser diode in the optical block. Be sure ground body and workbench, and use care the clothes do not touch the diode.

- 1) After the connection, remove solder shown in right figure.

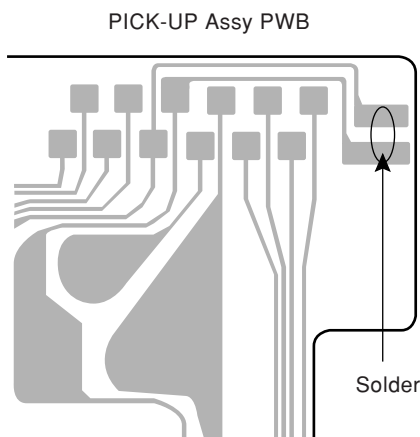

NOTE ON BEFORE STARTING REPAIR

1. Forced discharge of electrolytic capacitor of power supply block

When repair is going to be attempted in the set that uses relay circuit in the power supply block, electric potential is kept charged across the electrolytic capacitors (C101, 102) even though AC power cord is removed. If repair is attempted in this condition, secondary defect can occur.

In order to prevent the secondary trouble, perform the following measures before starting repair work.

Discharge procedure

- ① Remove the AC power cord.
- ② Connect a discharging resistor at an end of lead wire that has clips at both ends. Connect the other end of the lead wire to metal chassis.
- ③ Contact the other end of the discharging resistor to the positive (+) side (+VH) of C101. (For two seconds)
- ④ Contact the same end of the discharging resistor as step ③ to the negative (-) side (-VH) of C102 in the same way. (For two seconds)
- ⑤ Check that voltage across C101 and C102 has decreased to 1 V or less using a multimeter or an oscilloscope.

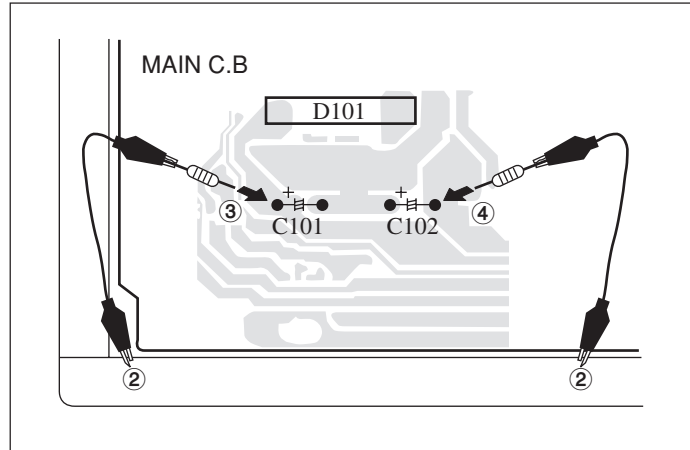

Fig-1

Select a discharging resistor referring to the following table.

Charging voltage (V) (C101, 102)	Discharging resistor (Ω)	Rated power (W)	Parts number
25-48	100	3	87-A00-247-090
49-140	220	5	87-A00-232-090

Note: The reference numbers (C101, C102) of the electrolytic capacitors can change depending on the models. Be sure to check the reference numbers of the charging capacitors on schematic diagram before starting the discharging work.

2. Check items before exchanging the MICROCOMPUTER

Be sure to check the following items before exchanging the MICROCOMPUTER. Exchange the MICROCOMPUTER after confirming that the MICROCOMPUTER is surely defective.

2-1. Regarding the HOLD terminal of the MICROCOMPUTER

When the HOLD terminal (INPUT) of the MICROCOMPUTER is "H", the MICROCOMPUTER is judged to be operating correctly. When this terminal is "L", the main power cannot be turned on. Therefore, be sure to check the terminal voltage of the HOLD terminal before exchange.

When the MICROCOMPUTER is not defective, the HOLD terminal can also go "L" when the POWER AMPLIFIER has any abnormalities that triggers the abnormality detection circuit on the MAIN C. B. that sets the HOLD terminal to "L".

- Good or no good judgement of the MICROCOMPUTER

- ① Turn on the AC main power.
- ② Confirm that the main power is turned on and the HOLD terminal of the MICROCOMPUTER keeps the "H" level or not.
- ③ When the HOLD terminal is "L" level, the abnormality detection circuit is judged to be working correctly and the MICROCOMPUTER is judged to be good.

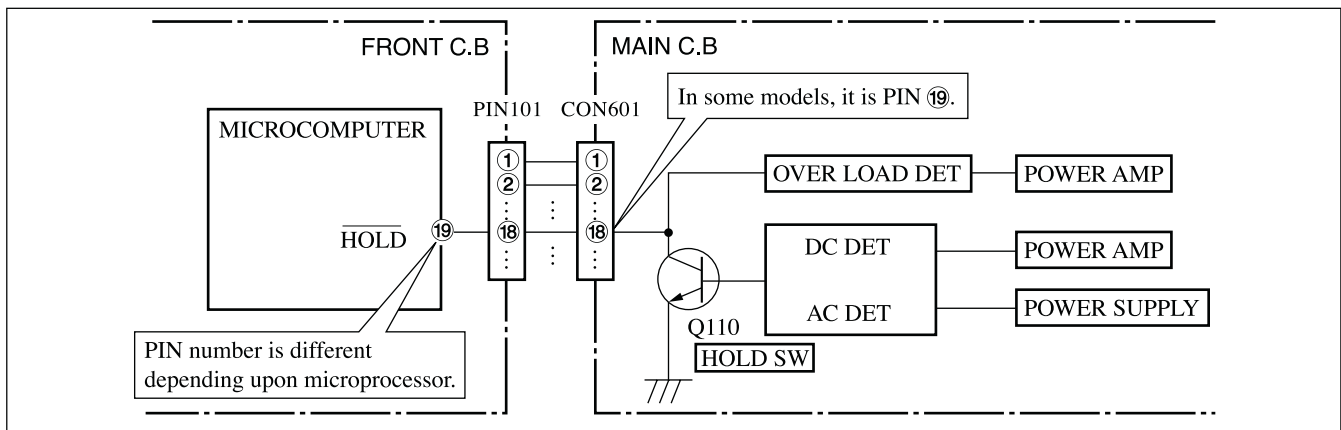

Fig-2-1

In such a case, check also if the POWER AMPLIFIER circuit or power supply circuit has any abnormalities or not.

2-2. Regarding reset

There are cases that the machine does not work correctly because the MICROCOMPUTER is not reset even though the AC power cord is re-inserted, or the software reset (pressing the STOP key + POWER key) is performed.

When the above described phenomenon occurs, it can lead to wrong judgement as if the MICROCOMPUTER is defective and to exchange the MICROCOMPUTER. In such a case, perform the forced-reset by the following procedure and check good or no good of the MICROCOMPUTER.

- ① Remove the AC power cord.

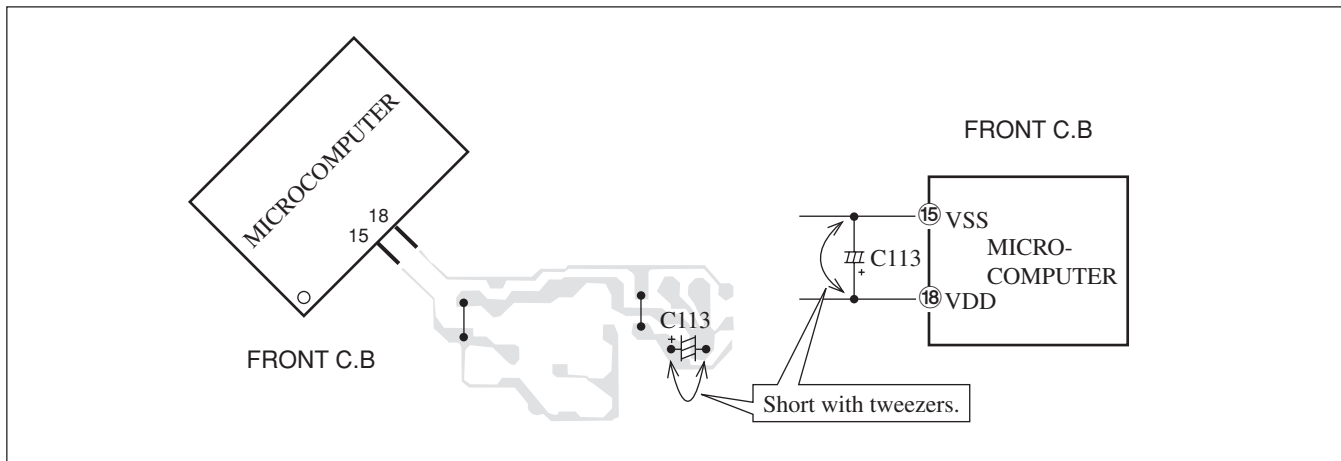

Fig-2-2

- ② Short both ends of the electrolytic capacitor C113 that is connected to VDD of the MICROCOMPUTER with tweezers.
- ③ Connect the AC power cord again. If the MICROCOMPUTER returns to the normal operation, the MICROCOMPUTER is good.

Note: The reference number or MICROCOMPUTER pin number of transistor (Q110) and electrolytic capacitor (C113) can change depending on the models. Be sure to check the reference numbers on schematic diagram before starting the discharging work.

2-3. Confirmation of soldering state of MICROCOMPUTER

Check the soldering state of the MICROCOMPUTER in addition to the above described procedures. Be sure to exchange the MICROCOMPUTER after surely confirming that the trouble is not caused by poor soldering but the MICROCOMPUTER itself.

ELECTRICAL MAIN PARTS LIST

REF. NO.	PART NO.	KANRI NO.	DESCRIPTION	REF. NO.	PART NO.	KANRI NO.	DESCRIPTION
IC				C10	87-010-759-080		C-CAP,U, 0.1-25F
	8B-NF7-631-030		C-IC,LC866560W-5V01	C11	87-010-759-080		C-CAP,U, 0.1-25F
	87-A21-831-010		IC,SPS-422-1-F1	C12	87-010-759-080		C-CAP,U, 0.1-25F
	87-A21-419-040		C-IC,NJM14558MD-TE2	C19	87-A12-382-000		CAP,E 2200-63 M 85 IV LELON<U>
	87-A21-893-040		C-IC,NJM14558V-TE2	C19	87-A12-383-000		CAP,E 3300-65 M 85 IV LELON<LH>
	87-A21-023-040		C-IC,BA3835F	C20	87-A12-382-000		CAP,E 2200-63 M 85 IV LELON<U>
	87-A21-401-040		C-IC,M61503FP	C20	87-A12-383-000		CAP,E 3300-65 M 85 IV LELON<LH>
	87-A21-695-010		IC,LA1845L	C21	87-A12-780-090		CAP,E 4700-35 M 85 SKR
	87-070-127-110		IC,LC72131D	C22	87-A12-780-090		CAP,E 4700-35 M 85 SKR
	87-A21-269-010		IC,EW732	C31	87-A12-091-080		CAP,E 10-50 SMG
TRANSISTOR				C32	87-012-286-080		CAP, U 0.01-25
	87-A30-494-080		TR,2SA1980G	C33	87-A12-062-080		CAP,E 100-10 SMG<U>
	87-A30-559-010		TR,CSB1370EF	C34	87-A12-072-080		CAP,E 100-25 SMG
	87-A30-492-080		TR,2SC5343G	C35	87-A12-071-080		CAP,E 47-25 SMG
	87-A30-076-080		C-TR,2SC3052F	C36	87-A12-067-080		CAP,E 330-16 SMG
	87-A30-075-080		C-TR,2SA1235F	C38	87-012-286-080		CAP, U 0.01-25
	87-A30-107-070		C-TR,CMBT5401	C60	87-A12-089-080		CAP,E 3.3-50 SMG
	87-A30-484-080		C-TR,KRA102S	C61	87-A12-071-080		CAP,E 47-25 SMG
	87-A30-190-080		TR,CC5551	C83	87-A12-074-080		CAP,E 470-25 SMG
	87-A30-106-040		C-TR,CMBT5551	C97	87-010-831-080		C-CAP,U,0.1-16F
	87-A30-098-010		TR,FP 1016	C101	87-012-279-080		C-CAP,U 2700P-50 B
	87-A30-097-010		TR,FN 1016	C102	87-012-279-080		C-CAP,U 2700P-50 B
	87-026-609-080		TR,KTA1266GR	C103	87-A12-084-080		CAP,E 0.22-50 SMG
	87-A30-087-080		C-FET,2SK2158	C104	87-A12-084-080		CAP,E 0.22-50 SMG
	87-A30-490-080		C-TR,KRC107S	C105	87-012-277-080		C-CAP, U 1800P-50 B<LH>
	87-A30-047-080		TR,CSD655E	C106	87-012-277-080		C-CAP, U 1800P-50 B<LH>
	87-A30-074-080		C-TR,RT1P 141C	C107	87-A12-089-080		CAP,E 3.3-50 SMG
	87-A30-162-010		FET,2SK2937	C108	87-A12-089-080		CAP,E 3.3-50 SMG
	87-A30-582-080		TR,CDAL585BC	C111	87-A12-077-080		CAP,E 33-35 SMG
	87-A30-495-080		TR,2SA1981Y	C112	87-A12-077-080		CAP,E 33-35 SMG
	87-A30-091-080		FET,2SJ460	C113	87-A10-596-080		C-CAP,S 100P-100 J CH
	87-A30-090-080		FET,2SK2541	C114	87-A10-596-080		C-CAP,S 100P-100 J CH
	87-A30-062-080		C-TR,KRC104S	C117	87-A12-317-080		C-CAP,U 0.1-50 Z F
	89-327-143-080		TR,2SC27140	C118	87-A12-317-080		C-CAP,U 0.1-50 Z F
	87-A30-489-080		C-TR,KRA107S	C119	87-012-286-080		CAP, U 0.01-25
	89-503-602-080		C-FET,2SK360E	C120	87-012-286-080		CAP, U 0.01-25
	87-A30-520-080		TR,2SC5342Y	C123	87-010-177-080		C-CAP,S 820P-50 SL
	87-A30-515-080		TR,2SA19790/Y	C124	87-010-177-080		C-CAP,S 820P-50 SL
	87-A30-234-080		TR,CSC4115BC	C133	87-012-282-080		CAP, U 4700P-50
	87-A30-216-080		TR,2SA933AS(R)	C140	87-012-278-080		C-CAP,U 2200P-50 B
DIODE				C186	87-010-759-080		C-CAP,U, 0.1-25F
	87-A40-393-090		DIODE,1N5402GW(F20)	C187	87-010-866-080		CAP, ELECT 10-63
	87-A40-291-080		DIODE,1N4148M(CPT)	C188	87-010-866-080		CAP, ELECT 10-63
	87-A40-838-090		DIODE,G3SBA60L-6088<U>	C225	87-A12-317-080		C-CAP,U 0.1-50 Z F
	87-A40-839-090		DIODE,G5SBA60L-6088<LH>	C226	87-A12-317-080		C-CAP,U 0.1-50 Z F
	87-A40-781-080		ZENER,UZ36BSA	C227	87-A12-317-080		C-CAP,U 0.1-50 Z F
	87-A40-764-080		ZENER,UZ10BSC	C228	87-A12-317-080		C-CAP,U 0.1-50 Z F
	87-A40-553-080		DIODE,1N4003 LES	C241	87-010-831-080		C-CAP,U,0.1-16F
	87-A40-270-080		C-DIODE,MC2838	C301	87-012-275-080		C-CAP,U 1200P-50 B<U>
	87-A40-269-080		C-DIODE,MC2836	C301	87-012-274-080		CHIP CAP,U 1000P-50B<LH>
	87-A40-488-080		DIODE,1SS244<LH>	C302	87-012-275-080		C-CAP,U 1200P-50 B<U>
	87-A40-748-080		ZENER,UZ5.6BSA	C302	87-012-274-080		CHIP CAP,U 1000P-50B<LH>
	87-A40-747-080		ZENER,UZ5.1BSB	C303	87-012-275-080		C-CAP,U 1200P-50 B
	87-A40-749-080		ZENER,UZ5.6BSB	C304	87-012-275-080		C-CAP,U 1200P-50 B
	87-A40-802-080		ZENER,UZ5.1BSC	C307	87-A12-062-080		CAP,E 100-10 SMG
	87-A40-739-080		ZENER,UZ2.7BSA	C308	87-A12-062-080		CAP,E 100-10 SMG
	87-017-149-080		ZENER,HZS6A2L	C309	87-012-188-080		C-CAP,U 47P-50 CH
MAIN C.B				C310	87-012-188-080		C-CAP,U 47P-50 CH
C3	87-A12-317-080		C-CAP,U 0.1-50 Z F	C313	87-012-284-080		CAP, U 6800P-50
C4	87-A12-317-080		C-CAP,U 0.1-50 Z F	C314	87-012-284-080		CAP, U 6800P-50
C5	87-A12-317-080		C-CAP,U 0.1-50 Z F	C315	87-A12-062-080		CAP,E 100-10 SMG
C6	87-A12-317-080		C-CAP,U 0.1-50 Z F	C317	87-A12-085-080		CAP,E 0.33-50 SMG
C9	87-010-759-080		C-CAP,U, 0.1-25F	C318	87-A12-085-080		CAP,E 0.33-50 SMG
				C326	87-010-787-080		CAP, U 0.022-25
				C327	87-010-831-080		C-CAP,U,0.1-16F
				C360	87-A12-087-080		CAP,E 1-50 SMG
				C399	87-A10-039-080		C-CAP,U 470P-50 J CH
				C401	87-A12-083-080		CAP,E 0.1-50 SMG
				C402	87-A12-083-080		CAP,E 0.1-50 SMG
				C403	87-012-193-080		C-CAP,U 82P-50 CH

REF. NO.	PART NO.	KANRI NO.	DESCRIPTION	REF. NO.	PART NO.	KANRI NO.	DESCRIPTION
C404	87-012-193-080		C-CAP,U 82P-50 CH	C803	87-010-787-080		CAP, U 0.022-25
C405	87-012-286-080		CAP, U 0.01-25	C804	87-A12-062-080		CAP,E 100-10 SMG
C406	87-012-286-080		CAP, U 0.01-25	C807	87-A12-086-080		CAP,E 0.47-50 SMG
C407	87-012-286-080		CAP, U 0.01-25	C808	87-A12-087-080		CAP,E 1-50 SMG
C408	87-012-286-080		CAP, U 0.01-25	C809	87-A12-087-080		CAP,E 1-50 SMG
C409	87-012-278-080		C-CAP,U 2200P-50 B	C810	87-010-831-080		C-CAP,U,0.1-16F
C410	87-012-278-080		C-CAP,U 2200P-50 B	C814	87-012-286-080		CAP, U 0.01-25
C411	87-A12-091-080		CAP,E 10-50 SMG	C815	87-A12-086-080		CAP,E 0.47-50 SMG
C412	87-A12-091-080		CAP,E 10-50 SMG	C816	87-A12-086-080		CAP,E 0.47-50 SMG
C452	87-A12-069-080		CAP,E 22-25 SMG	C821	87-A12-091-080		CAP,E 10-50 SMG
C453	87-012-279-080		C-CAP,U 2700P-50 B	C823	87-A10-978-080		C-CAP,U 820P-25 J CH
C454	87-012-279-080		C-CAP,U 2700P-50 B	C824	87-A12-090-080		CAP,E 4.7-50 SMG
C455	87-012-279-080		C-CAP,U 2700P-50 B	C825	87-010-596-080		CAP, S 0.047-16
C456	87-012-286-080		CAP, U 0.01-25	C842	87-012-286-080		CAP, U 0.01-25
C457	87-A12-361-080		CAP,M 5600P-100 J CP	C844	87-012-286-080		CAP, U 0.01-25
C458	87-012-274-080		CHIP CAP,U 1000P-50B	C850	87-A12-071-080		CAP,E 47-25 SMG
C459	87-012-271-080		CAP, U 560P-50	C851	87-012-286-080		CAP, U 0.01-25
C460	87-010-831-080		C-CAP,U,0.1-16F	C852	87-012-286-080		CAP, U 0.01-25
C461	87-012-158-080		C-CAP,S 390P-50 CH	C853	87-012-286-080		CAP, U 0.01-25
C462	87-012-158-080		C-CAP,S 390P-50 CH	C858	87-010-831-080		C-CAP,U,0.1-16F
C470	87-018-127-080		CAP, CER 470P-50V	C901	87-018-145-080		CAP,TC-U 6.8P-50 CH
C605	87-012-280-080		CAP, U 3300P-50	C904	87-012-286-080		CAP, U 0.01-25
C606	87-012-280-080		CAP, U 3300P-50	C905	87-012-286-080		CAP, U 0.01-25
C609	87-010-785-080		C-CAP,U0.015-25BK	C907	87-012-286-080		CAP, U 0.01-25
C610	87-010-785-080		C-CAP,U0.015-25BK	C908	87-A10-915-080		C-CAP,U 1000P-25 J CH
C611	87-A12-084-080		CAP,E 0.22-50 SMG	C909	87-012-286-080		CAP, U 0.01-25
C612	87-A12-084-080		CAP,E 0.22-50 SMG	C910	87-012-174-080		CAP CHIP CERA SS 12P CHJ
C613	87-A12-084-080		CAP,E 0.22-50 SMG	C911	87-012-170-080		C-CAP,U 8P-50 CH
C614	87-A12-084-080		CAP,E 0.22-50 SMG	C912	87-012-195-080		C-CAP,U 100P-50CH
C615	87-012-172-080		CAPACITOR CHIP U 10P CH	C913	87-012-286-080		CAP, U 0.01-25
C616	87-016-459-080		CAP,E 470-10 SMG	C914	87-012-166-080		C-CAP,U 4P-50 CH
C617	87-016-459-080		CAP,E 470-10 SMG	C915	87-012-174-080		CAP CHIP CERA SS 12P CHJ
C618	87-A12-091-080		CAP,E 10-50 SMG	C916	87-012-180-080		C-CAP,U 22P-50 CH
C620	87-010-263-080		CAP, ELECT 100-10V	C917	87-012-186-080		C-CAP,U 39P-50 CH
C623	87-A12-084-080		CAP,E 0.22-50 SMG<U>	C918	87-A10-039-080		C-CAP,U 470P-50 J CH
C623	87-A12-087-080		CAP,E 1-50 SMG<LH>	C921	87-012-195-080		C-CAP,U 100P-50CH
C624	87-A12-084-080		CAP,E 0.22-50 SMG<U>	C922	87-012-174-080		CAP CHIP CERA SS 12P CHJ
C624	87-A12-087-080		CAP,E 1-50 SMG<LH>	C959	87-010-831-080		C-CAP,U,0.1-16F
C630	87-A10-260-080		C-CAP,U 0.1-16 K B	C960	87-010-831-080		C-CAP,U,0.1-16F
C631	87-012-281-080		C-CAP,U 3900P-50 B	C961	87-012-167-080		C-CAP,U 5P-50 CH
C632	87-012-281-080		C-CAP,U 3900P-50 B	C963	87-015-785-080		CHIP CAPACITOR, 0.1FZ-25Z
C633	87-A11-070-080		C-CAP,U 0.033-16 K B	C971	87-A12-067-080		CAP,E 330-16 SMG
C634	87-A11-070-080		C-CAP,U 0.033-16 K B	C972	87-A12-090-080		CAP,E 4.7-50 SMG
C661	87-012-336-080		C-CAP,U 330P-50J SL	C973	87-012-286-080		CAP, U 0.01-25
C662	87-012-336-080		C-CAP,U 330P-50J SL	C974	87-012-286-080		CAP, U 0.01-25
C671	87-010-831-080		C-CAP,U,0.1-16F<LH>	C979	87-012-195-080		C-CAP,U 100P-50CH
C672	87-010-831-080		C-CAP,U,0.1-16F<LH>	C981	87-A12-071-080		CAP,E 47-25 SMG
C673	87-010-182-080		C-CAP,S 2200P-50 B<LH>	C982	87-010-831-080		C-CAP,U,0.1-16F
C677	87-012-286-080		CAP, U 0.01-25	C983	87-012-286-080		CAP, U 0.01-25
C771	87-A12-062-080		CAP,E 100-10 SMG	C984	87-012-286-080		CAP, U 0.01-25
C772	87-012-286-080		CAP, U 0.01-25	C987	87-012-286-080		CAP, U 0.01-25
C782	87-012-286-080		CAP, U 0.01-25	C991	87-012-176-080		CAP 15P
C783	87-012-286-080		CAP, U 0.01-25	C992	87-012-176-080		CAP 15P
C784	87-012-286-080		CAP, U 0.01-25	C993	87-012-274-080		CHIP CAP,U 1000P-50B
C785	87-012-286-080		CAP, U 0.01-25	C995	87-012-274-080		CHIP CAP,U 1000P-50B
C786	87-012-286-080		CAP, U 0.01-25	C997	87-010-831-080		C-CAP,U,0.1-16F
C788	87-012-167-080		C-CAP,U 5P-50 CH	C998	87-A12-071-080		CAP,E 47-25 SMG
C789	87-A12-052-080		C-CAP,S 0.033-25 J B	C999	87-A11-155-080		CAP,TC U 0.01-16 Z F
C790	87-A12-052-080		C-CAP,S 0.033-25 J B	CF831	87-008-261-010		FILTER,CF SFE10.7MA5-A
C791	87-010-831-080		C-CAP,U,0.1-16F	CF832	87-008-261-010		FILTER,CF SFE10.7MA5-A
C792	87-012-286-080		CAP, U 0.01-25	CN301	87-A60-620-010		CONN,3P V 2MM JMT
C793	87-A12-090-080		CAP,E 4.7-50 SMG	CN351	87-A60-625-010		CONN,8P V 2MM JMT
C795	87-012-286-080		CAP, U 0.01-25	CN601	87-099-719-010		CONN,30P H BLK TYK-B(X)
C796	87-012-286-080		CAP, U 0.01-25	CN602	87-A60-131-010		CONN,6P V FE
C797	87-A12-091-080		CAP,E 10-50 SMG	CNA1	8A-NF8-653-010		CONN ASSY,9P TID-A(480)<U>
C798	87-012-286-080		CAP, U 0.01-25	D902	87-A40-128-080		C-VARI-CAP,HVU202A
C799	87-A12-093-080		CAP,E 33-50 SMG	D903	87-A40-128-080		C-VARI-CAP,HVU202A
C800	87-010-829-080		CAP, U 0.047-16	FC602	88-906-251-110		FF-CABLE,6P 1.25 (RVS-FACE)
C801	87-A12-089-080		CAP,E 3.3-50 SMG	J201	87-A60-488-010		JACK,DIA6.3BLK ST W/SWKM16AT<U>
C802	87-010-829-080		CAP, U 0.047-16	J201	87-A61-480-010		JACK,DIA6.3BLK ST W/SW MSC16A<LH>

REF. NO.	PART NO.	KANRI NO.	DESCRIPTION	REF. NO.	PART NO.	KANRI NO.	DESCRIPTION
J203	87-A60-238-010		TERMINAL, SP 4P (MSC)	C173	87-010-421-040		CAP,E 4.7-50 5L
J602	87-A60-881-010		JACK,PIN 2P MSP 242V05 PBSN	C174	87-010-421-040		CAP,E 4.7-50 5L
J831	87-A60-202-010		TERMINAL,ANT 4P MSP-154V-02	C180	87-010-759-080		C-CAP,U, 0.1-25F
JR123	87-A10-596-080		C-CAP,S 100P-100 J CH	C185	87-010-759-080		C-CAP,U, 0.1-25F
JR124	87-A10-596-080		C-CAP,S 100P-100 J CH	C186	87-012-274-080		CHIP CAP,U 1000P-50B
L201	87-A50-610-010		COIL,1UH K(MDEC)	C188	87-012-369-080		C-CAP,S 0.047-50F
L202	87-A50-610-010		COIL,1UH K(MDEC)	C191	87-012-286-080		CAP, U 0.01-25
L451	87-007-342-010		COIL,OSC 85K HZ BIAS	C192	87-010-759-080		C-CAP,U, 0.1-25F
L801	87-A50-608-010		COIL,FM DET-N(TOK)	C251	87-A12-094-080		CAP,E 47-50 SMG
L802	87-A91-551-010		FLTR,PCFJZH-450 L(TOK)	C315	87-010-759-080		C-CAP,U, 0.1-25F
L811	87-005-847-080		COIL,2.2UH K CECS	C451	87-010-759-080		C-CAP,U, 0.1-25F
L832	87-005-847-080		COIL,2.2UH K CECS	C452	87-010-759-080		C-CAP,U, 0.1-25F
L902	88-ZA1-602-110		COIL,FM-RF-U2 2G	C453	87-010-759-080		C-CAP,U, 0.1-25F
L903	88-ZA1-601-010		COIL,FM-RF-U1 2G	C454	87-010-759-080		C-CAP,U, 0.1-25F
L904	87-005-847-080		COIL,2.2UH K CECS	C455	87-010-759-080		C-CAP,U, 0.1-25F
L905	88-ZA1-624-010		COIL,FM IFT 7-6.2 (COILS)	C502	87-012-282-080		CAP, U 4700P-50<LH>
L906	88-ZA1-603-010		COIL,FM-OSC-U 2G	C503	87-010-112-040		CAP,E 100-16<LH>
L951	8A-NF8-667-010		COIL,AM PACK 4(TOK)	C505	87-010-546-040		CAP,E 0.33-50<LH>
R129	87-A00-262-080		RES,M/F 0.15-2W J	C506	87-012-191-080		CHIP CAP 68 PF<LH>
R130	87-A00-262-080		RES,M/F 0.15-2W J	C507	87-010-545-040		CAP,E 0.22-50 SME<LH>
R131	87-A00-262-080		RES,M/F 0.15-2W J	C508	87-010-544-040		CAP,E 0.1-50 SME<LH>
R132	87-A00-262-080		RES,M/F 0.15-2W J	C510	87-012-195-080		C-CAP,U 100P-50CH<LH>
R243	87-A01-001-050		RES,220-1/2W J BLT2J<U>	C511	87-A12-065-080		CAP,E 33-16 SM<LH>
R243	87-A00-440-050		RES,220-1/2W J RP<LH>	C512	87-012-274-080		CHIP CAP,U 1000P-50B<LH>
R244	87-A01-001-050		RES,220-1/2W J BLT2J<U>	C514	87-010-759-080		C-CAP,U, 0.1-25F<LH>
R244	87-A00-440-050		RES,220-1/2W J RP<LH>	C515	87-012-274-080		CHIP CAP,U 1000P-50B<LH>
R245	87-A00-999-050		RES,180-1/2W J BLT2J<U>	C517	87-012-274-080		CHIP CAP,U 1000P-50B<LH>
R245	87-A00-440-050		RES,220-1/2W J RP<LH>	C518	87-010-759-080		C-CAP,U, 0.1-25F<LH>
R246	87-A00-999-050		RES,180-1/2W J BLT2J<U>	C520	87-012-273-080		C-CAP,U 820P-50 B<LH>
R246	87-A00-440-050		RES,220-1/2W J RP<LH>	CN101	87-099-720-010		CONN,30P BLK TYK-B(P)
R790	87-012-286-080		CAP, U 0.01-25	CN103	87-099-196-010		CONN,8P V BLK 6216
R991	87-012-195-080		C-CAP,U 100P-50CH	CN201	87-099-017-010		CONN, 15P V BLK 6216<LH>
R993	87-012-195-080		C-CAP,U 100P-50CH	CN202	87-099-013-010		CONN,11P V BLK 6216<U>
R995	87-012-195-080		C-CAP,U 100P-50CH	CN301	87-099-209-010		CONN,4P H BLK 6216
SFR451	87-A90-557-080		SFR,33K H HOKU	CN303	87-099-209-010		CONN,4P H BLK 6216
SFR452	87-A90-557-080		SFR,33K H HOKU	CN911	87-099-212-010		CONN,5P V BLK 6216
TH101	87-A91-042-080		C-THMS,100K 55001	CNA901	8B-NF7-620-010		CONN ASSY,3P V 120MM
TH102	87-A91-042-080		C-THMS,100K 55001	FB501	87-008-372-080		FILTER, EMI BL01 IN1<LH>
W99	8B-NFJ-620-010		F-CABLE,9P 2.5 280MM<U>	FC103	88-908-301-110		FF-CABLE,8P 1.25
WH1	87-A90-510-010		HLDR,WIRE 2.5-9P	FC201	88-915-101-110		FF-CABLE,15P 1.25 100MM<LH>
X992	87-A70-306-010		VIB,XTAL 4.500MHZ CSA-309ST	FC202	88-911-101-110		FF-CABLE,11P 1.25<U>
				FC301	88-904-091-110		FF-CABLE,4P 1.25 90MM
				FC303	88-904-091-110		FF-CABLE,4P 1.25 90MM
				FC911	88-905-151-110		FF-CABLE,5P 1.25 150MM
				FL401	8B-NF7-621-010		FL,BJ815GNK
FRONT C.B				J502	87-A61-243-010		JACK,6.3 BLK MONO W/SW V MSC<LH>
C39	87-A10-039-080		C-CAP,U 470P-50 J CH	L151	87-A50-656-010		COIL,CLK 5.76MHZ (TOKO)7KLY
C40	87-012-195-080		C-CAP,U 100P-50CH	LED401	87-A40-589-040		LED,SLR-56VCT31 RED
C41	87-012-195-080		C-CAP,U 100P-50CH	S162	87-A91-645-010		SW,RTRY EC12E24304NON-CLICK
C42	87-012-195-080		C-CAP,U 100P-50CH	S301	87-A90-095-080		SW,TACT EVQ11G04M
C43	87-012-195-080		C-CAP,U 100P-50CH	S302	87-A90-095-080		SW,TACT EVQ11G04M
C44	87-012-195-080		C-CAP,U 100P-50CH	S321	87-A90-095-080		SW,TACT EVQ11G04M
C45	87-012-195-080		C-CAP,U 100P-50CH	S322	87-A90-095-080		SW,TACT EVQ11G04M
C46	87-012-195-080		C-CAP,U 100P-50CH	S323	87-A90-095-080		SW,TACT EVQ11G04M
C47	87-012-195-080		C-CAP,U 100P-50CH	S324	87-A90-095-080		SW,TACT EVQ11G04M
C48	87-012-199-080		CAP 220P	S326	87-A90-095-080		SW,TACT EVQ11G04M
C49	87-012-145-080		CAP, CHIP S 270P CH	S327	87-A90-095-080		SW,TACT EVQ11G04M
C50	87-012-145-080		CAP, CHIP S 270P CH	S335	87-A90-095-080		SW,TACT EVQ11G04M
C141	87-012-278-080		C-CAP,U 2200P-50 B	VR501	87-NB7-602-010		VR,RTRY 10KAX1 1 V<LH>
C142	87-010-785-080		C-CAP,U0.015-25BK				
C153	87-016-083-080		C-CAP,S 0.15-16 RK<700LH>				
C153	87-A11-058-080		C-CAP,U 0.22-10 KB<700U,705LH>				
C154	87-A10-189-040		CAP,E 220-10	PT C.B			
C155	87-012-176-080		CAP 15P				
C156	87-012-198-080		CAP 180P	CN1	87-A61-110-010		CONN,9P V TID-A<LH>
C158	87-A10-039-080		C-CAP,U 470P-50 J CH	△ PT1	8B-NFJ-602-010		PT,BNF-18 LH<LH>
				△ PT1	8B-NFJ-601-010		PT,BNF-18 U<U>
C161	87-012-274-080		CHIP CAP,U 1000P-50B	△ PT2	8B-MA6-673-010		PT,SUB BMA H (VRK)<LH>
C162	87-012-274-080		CHIP CAP,U 1000P-50B	△ PT81	8B-MA6-671-010		PT,SUB BMA U (VRK)<U>
C165	87-012-157-080		C-CAP,S 330P-50 CH				
C166	87-010-552-040		CAP,E 22-16 M 5L SRE	△ RY1	87-A91-339-010		RELAY,AC DC12V G5PA-2<LH>
C171	87-012-369-080		C-CAP,S 0.047-50F	△ RY81	87-A91-418-010		RELAY,AC12V G5PA-1-M<U>
				△ S1	87-A90-165-010		SW,SL 1-2-3 SWS2301<LH>
C172	87-A12-094-080		CAP,E 47-50 SMG				

REF. NO.	PART NO.	KANRI NO.	DESCRIPTION	REF. NO.	PART NO.	KANRI NO.	DESCRIPTION
△ T1	87-A60-317-010		TERMINAL, 1P MSC<LH>				
△ T2	87-A60-317-010		TERMINAL, 1P MSC<LH>				
△ T81	87-A60-317-010		TERMINAL, 1P MSC<U>				
T82	87-A60-317-010		TERMINAL, 1P MSC<U>	S901	87-036-252-010		SW,MICRO SPPB51
WH81	87-A90-510-010		HLDR,WIRE 2.5-9P<U>	S902	87-036-252-010		SW,MICRO SPPB51
M-OP-PANEL C.B				DECK C.B <U>			
C391	87-012-274-080		CHIP CAP,U 1000P-50B	CN1	87-099-753-010		CONN,11P H 9604
C392	87-012-199-080		CAP 220P	SFR1	87-024-581-010		SFR,3.3K H KVVSF637A
CN304	87-099-209-010		CONN,4P H BLK 6216	SOL1	82-ZM3-627-010		SOL ASSY,27
S341	87-A90-095-080		SW,TACT EVQ11G04M	SOL2	82-ZM3-627-010		SOL ASSY,27
S342	87-A90-095-080		SW,TACT EVQ11G04M	SW1	87-A90-673-010		SW,MICRO ESE11SH1C
S343	87-A90-095-080		SW,TACT EVQ11G04M	SW2	87-A91-500-010		SW,MICRO MPU11470MLB0
S344	87-A90-095-080		SW,TACT EVQ11G04M	SW3	87-A91-500-010		SW,MICRO MPU11470MLB0
S345	87-A90-095-080		SW,TACT EVQ11G04M	SW4	87-A91-500-010		SW,MICRO MPU11470MLB0
S346	87-A90-095-080		SW,TACT EVQ11G04M	SW5	87-A90-673-010		SW,MICRO ESE11SH1C
S347	87-A90-095-080		SW,TACT EVQ11G04M	DECK C.B <LH>			
S348	87-A90-095-080		SW,TACT EVQ11G04M	CON1	87-099-756-010		CONN,15P 9604S F
S349	87-A90-095-080		SW,TACT EVQ11G04M	M1	87-045-347-010		MOT,SHU2L 70
S350	87-A90-095-080		SW,TACT EVQ11G04M	SFR1	87-024-581-010		SFR,3.3K H KVVSF637A
S351	87-A90-095-080		SW,TACT EVQ11G04M	SOL1	82-ZM3-627-010		SOL ASSY 27 SO
S352	87-A90-095-080		SW,TACT EVQ11G04M	SOL2	82-ZM3-627-010		SOL ASSY 27 SO
S371	87-A91-991-010		SW,RTRY REO12303PVB8H	SW1	87-A90-248-010		SW,MICRO ESE11SH2CXQ
S-OP-PANEL C.B				SW2	87-A90-248-010		SW,MICRO ESE11SH2CXQ
CN302	87-A60-083-010		CONN,04P H 9604S-04F	SW4	87-036-110-010		SW,MICRO SPPB62
S303	87-A90-095-080		SW,TACT EVQ11G04M	SW6	87-036-110-010		SW,MICRO SPPB62
S304	87-A90-095-080		SW,TACT EVQ11G04M	SW8	87-A90-248-010		SW,MICRO ESE11SH2CXQ
S305	87-A90-095-080		SW,TACT EVQ11G04M<LH>	SW9	87-A90-248-010		SW,MICRO ESE11SH2CXQ
S306	87-A90-095-080		SW,TACT EVQ11G04M<LH>	HEAD-1<LH>			
S307	87-A90-095-080		SW,TACT EVQ11G04M	CON301	87-NF6-615-010		CONN ASSY,3P PB
S308	87-A90-095-080		SW,TACT EVQ11G04M		85-ZM3-602-010		PWB,FLEX A
S329	87-A90-095-080		SW,TACT EVQ11G04M	HEAD-2<LH>			
S330	87-A90-095-080		SW,TACT EVQ11G04M	CON351	87-NF6-616-010		CONN ASSY,8P RPB
S332	87-A90-095-080		SW,TACT EVQ11G04M		85-ZM3-602-010		PWB,FLEX A
S333	87-A90-095-080		SW,TACT EVQ11G04M	MOTOR C.B			
CN912	87-099-210-010		CONN,5P H BLK 6216				
S911	87-036-109-010		SW,MICRO SPPB61				
S912	87-036-109-010		SW,MICRO SPPB61				

チップ抵抗部品コード/CHIP RESISTOR PART CODE

チップ抵抗部品コードの成り立ち
Chip Resistor Part Coding

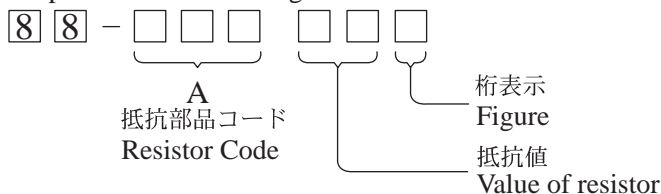

チップ抵抗
Chip resistor

容量 Wattage	種類 Type	許容誤差 Tolerance	記号 Symbol	寸法/Dimensions (mm)			抵抗コード : A Resistor Code : A	
				外形/Form	L	W		t
1/16W	1005	± 5%	CJ		1.0	0.5	0.35	104
1/16W	1608	± 5%	CJ		1.6	0.8	0.45	108
1/10W	2125	± 5%	CJ		2	1.25	0.45	118
1/8W	3216	± 5%	CJ		3.2	1.6	0.55	128

TRANSISTOR ILLUSTRATION

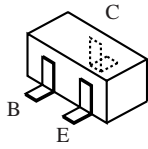

2SA1235F
2SC2714O
2SC3052F
KRA102S
KRA107S
KRC104S
KRC107S
CMBT5401
CMBT5551
RT1P141C



E C B

2SA1980G
2SA1981Y
2SA1979O/Y
2SC5343G
2SC5342Y
CSD655E



E C B

CC5551
CDA1585BC
CSC4115BC
KTA1266GR

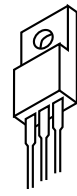

B C E

CSB1370EF

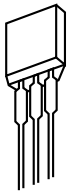

E C B

2SA933AS(R)

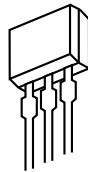

S D G

2SJ460
2SK2541

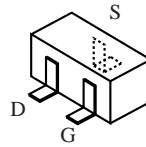

2SK360E

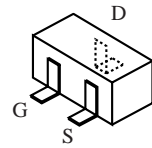

2SK2158

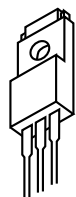

G D S

2SK2937

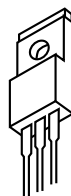

B C E

FN1016
FP1016

A MAIN C.B

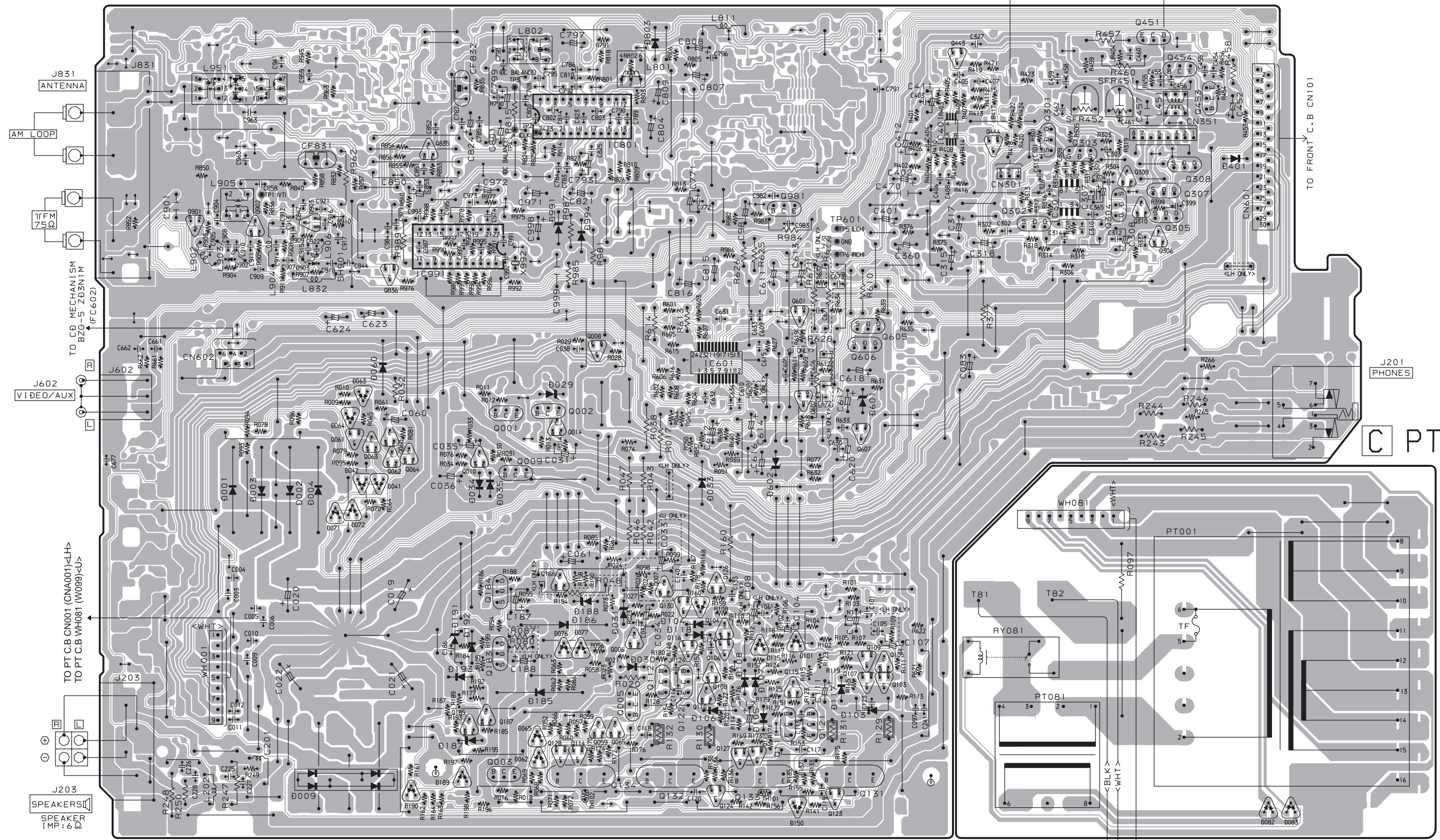

LH: TO HEAD-1 C.B CON301
U: TO DECK-1 CON301
LH: TO HEAD-2 C.B CON351
U: TO DECK-2 CON351

TO FRONT C.B CN101

C PT C.B
<U ONLY>

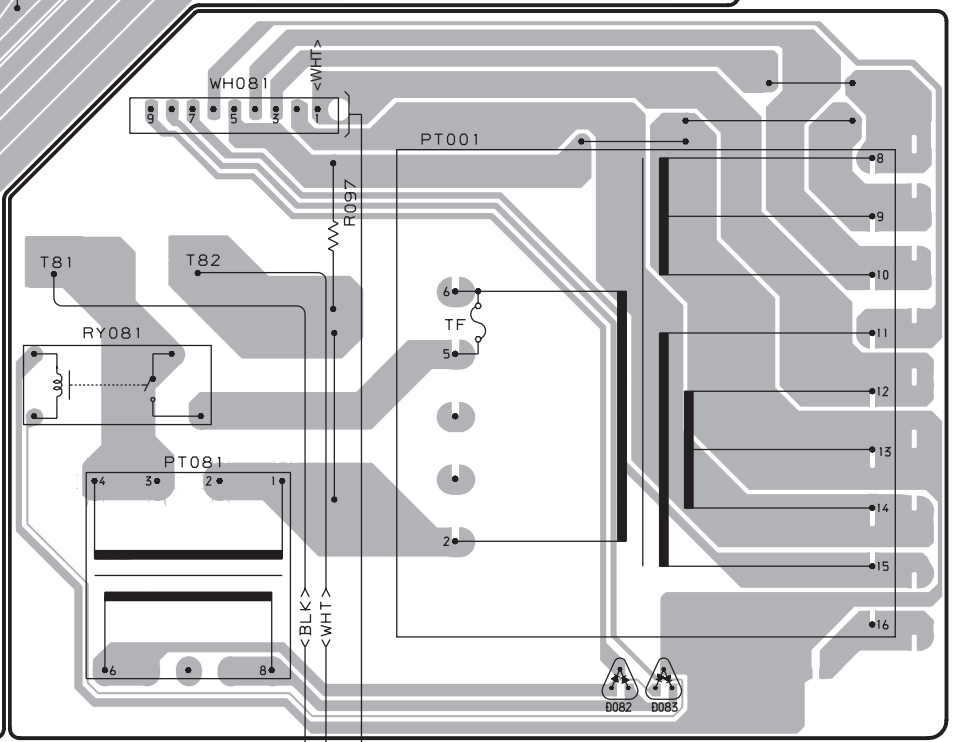

SCHEMATIC DIAGRAM-1 (MAIN 1/2:AMP SECTION)

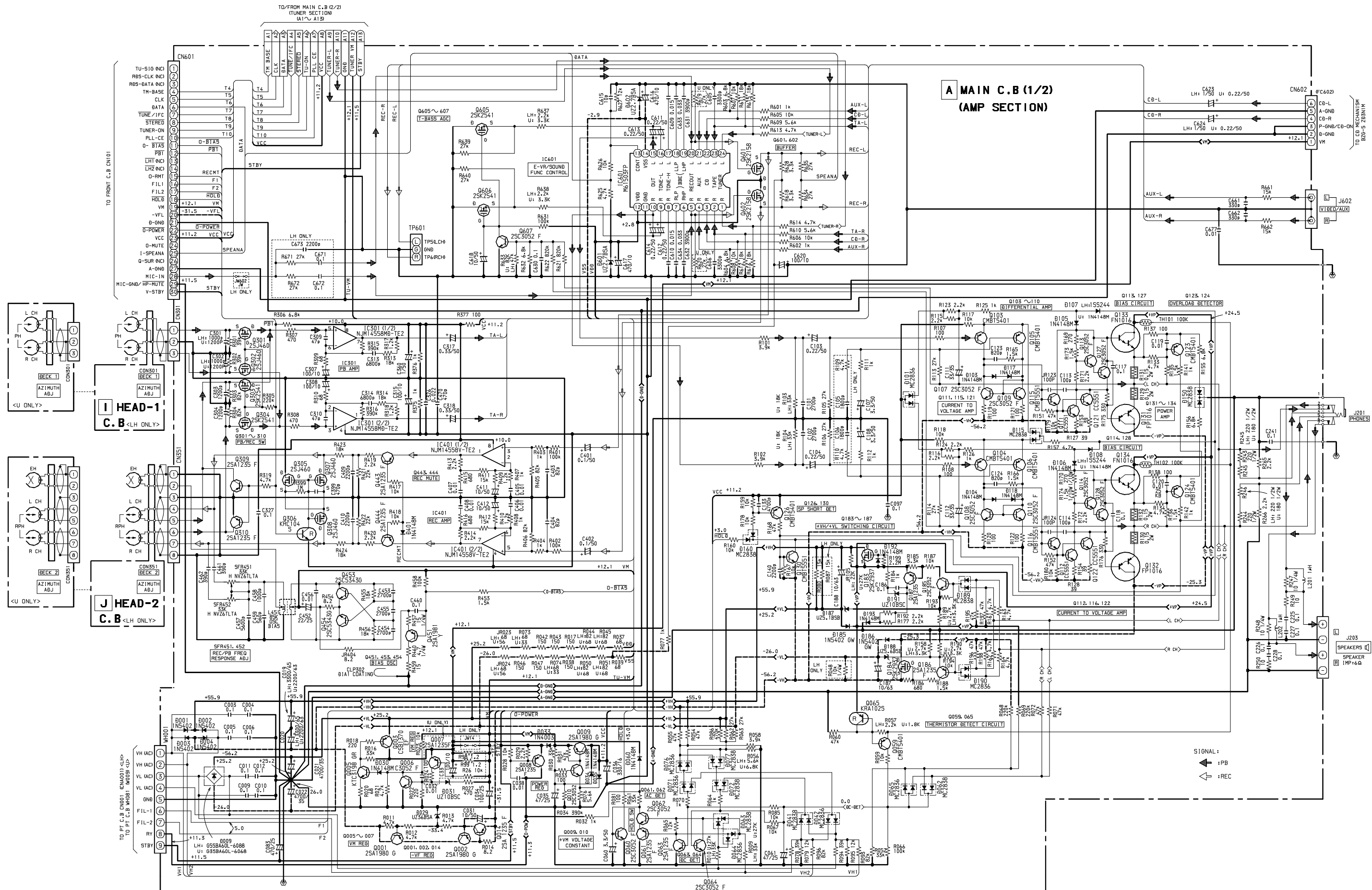

SCHEMATIC DIAGRAM-2 (MAIN 2/2:TUNER SECTION)

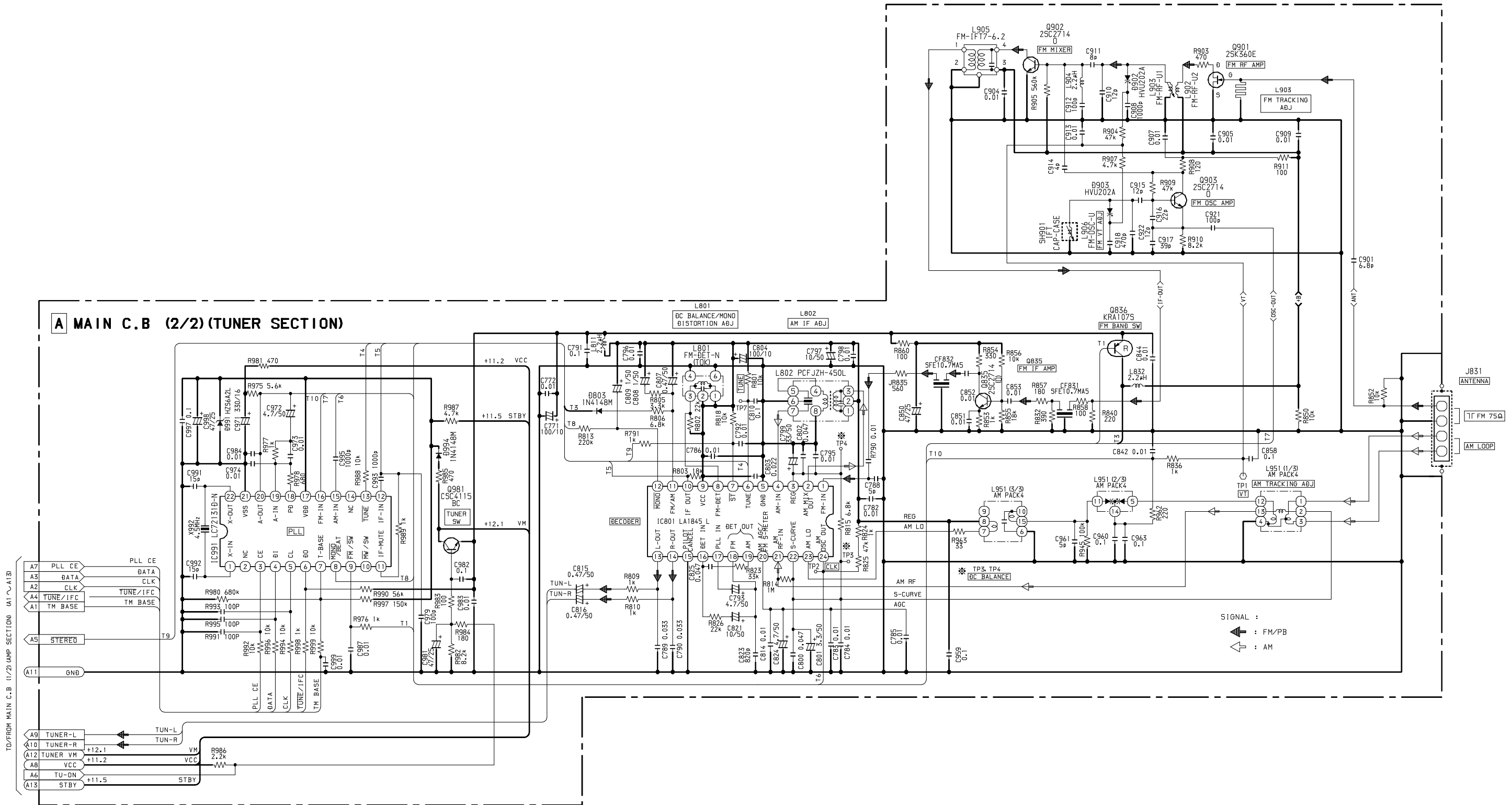

SCHEMATIC DIAGRAM - 3 (PT) <U>

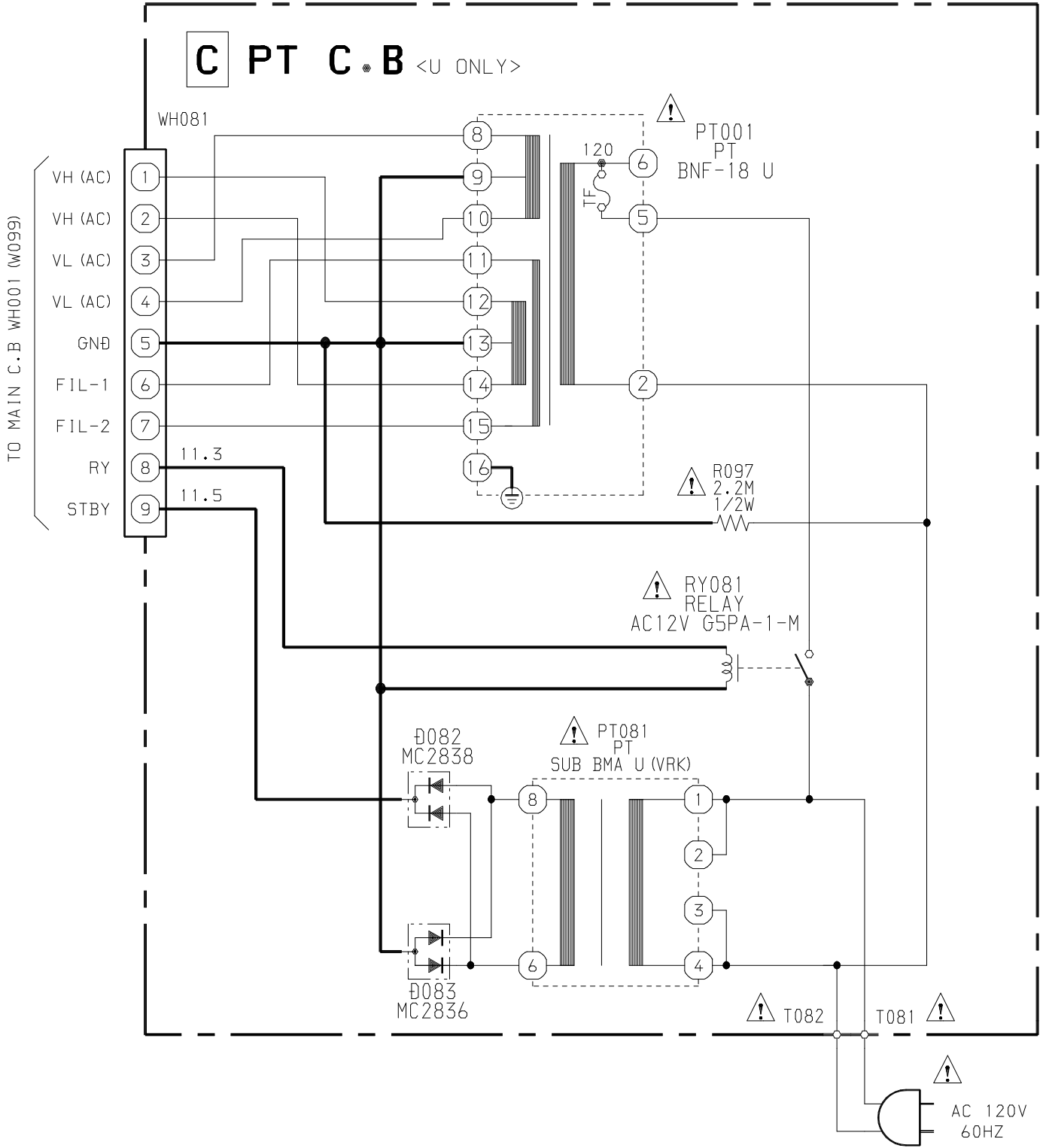

B FRONT C. B

S335 PANEL AUTO/MANU S162 VOLUME S327 PANEL OPEN/CLOSE S323 [CD] S324 VIDEO/AUX S322 TUNER/BAND S321 TAPE DECK 1/2 S302 ▲CD OPEN/CLOSE IC161 REMOTE SENSOR S326 [BEMO] S301, LED401 POWER ⊕ STANDBY/ON

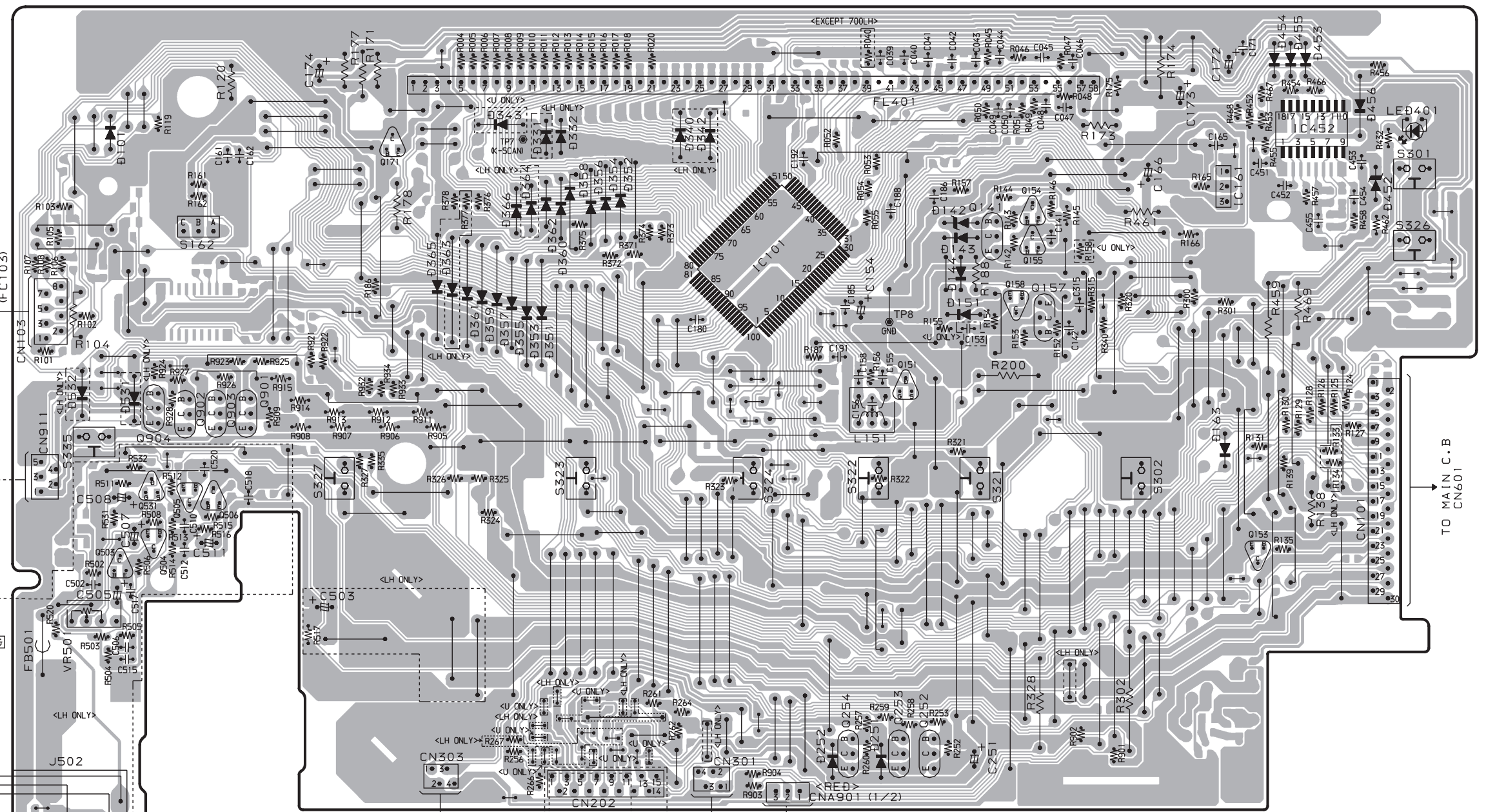

F MOTOR C. B

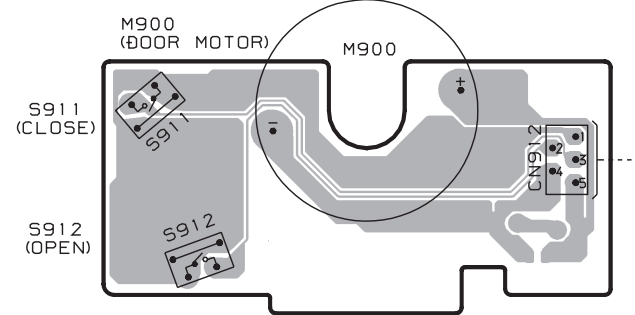

VR501 MIC MIXING

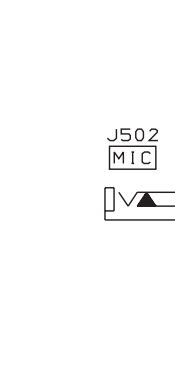

G BOX SW C. B

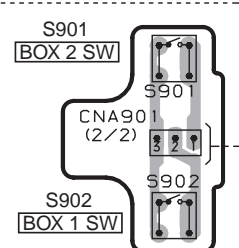

32	31	30	29	28	27	26	25	24	23	22	21	20	19	18	17	16	15	14	13	12	11	10	9	8	7	6	5	4	3	2	1
----	----	----	----	----	----	----	----	----	----	----	----	----	----	----	----	----	----	----	----	----	----	----	---	---	---	---	---	---	---	---	---

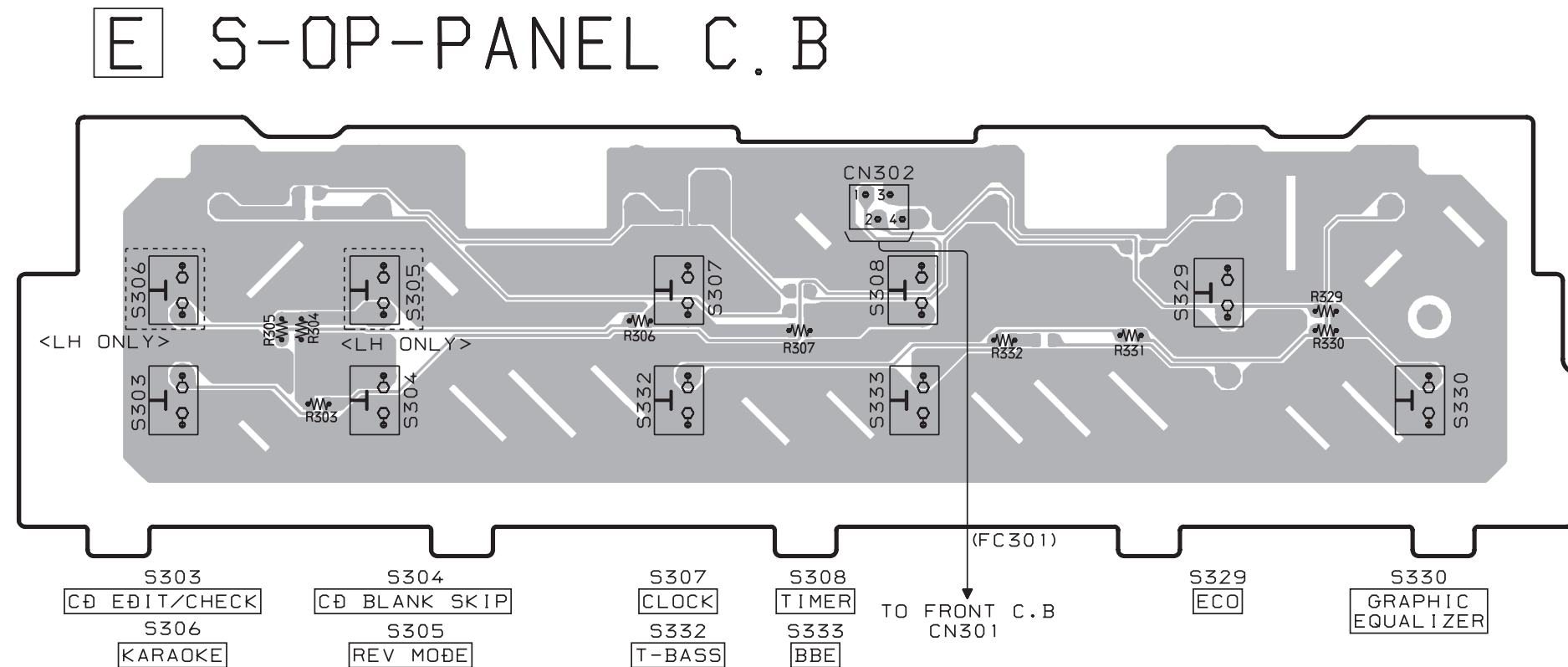
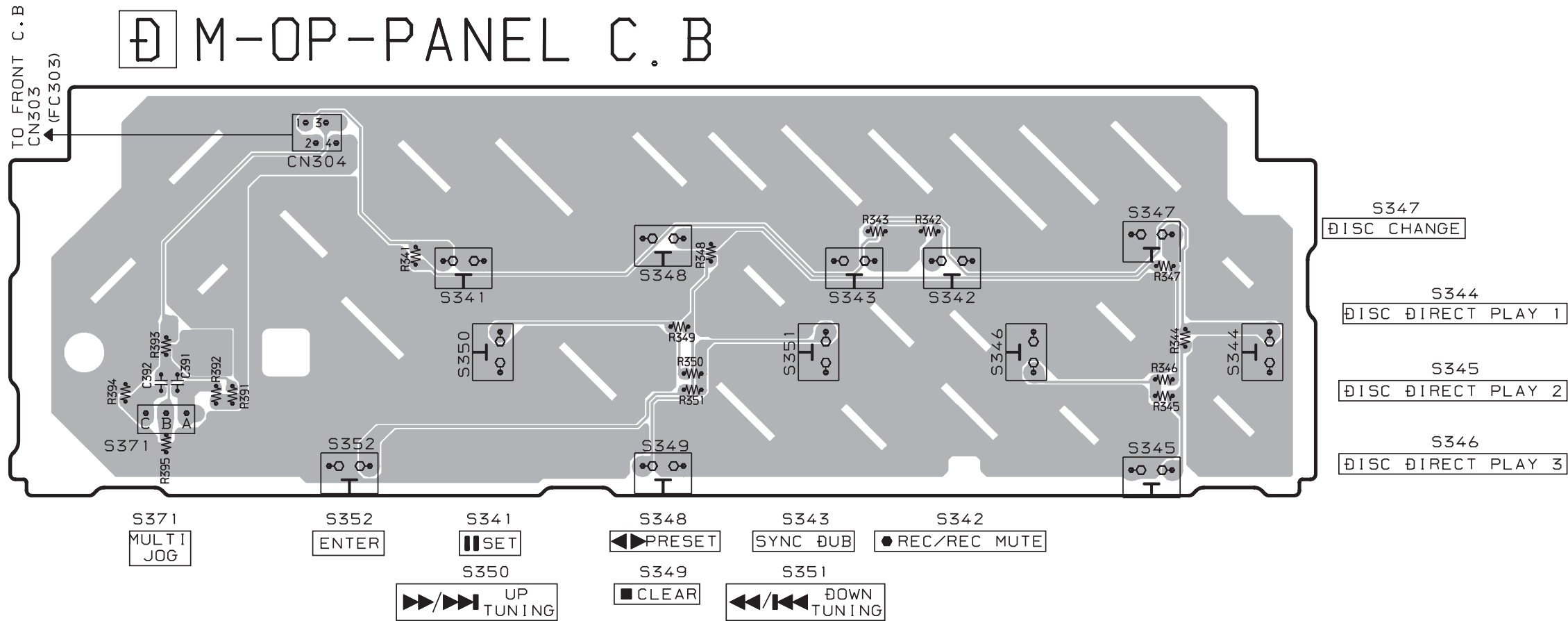

A
B
C
D
E
F
G
H
I
J
K
L
M
N
O
P
Q
R
S
T
U

SCHEMATIC DIAGRAM - 4 (U : FRONT / M-OP-PANEL / S-OP-PANEL / MOTOR / BOX SW / DECK)

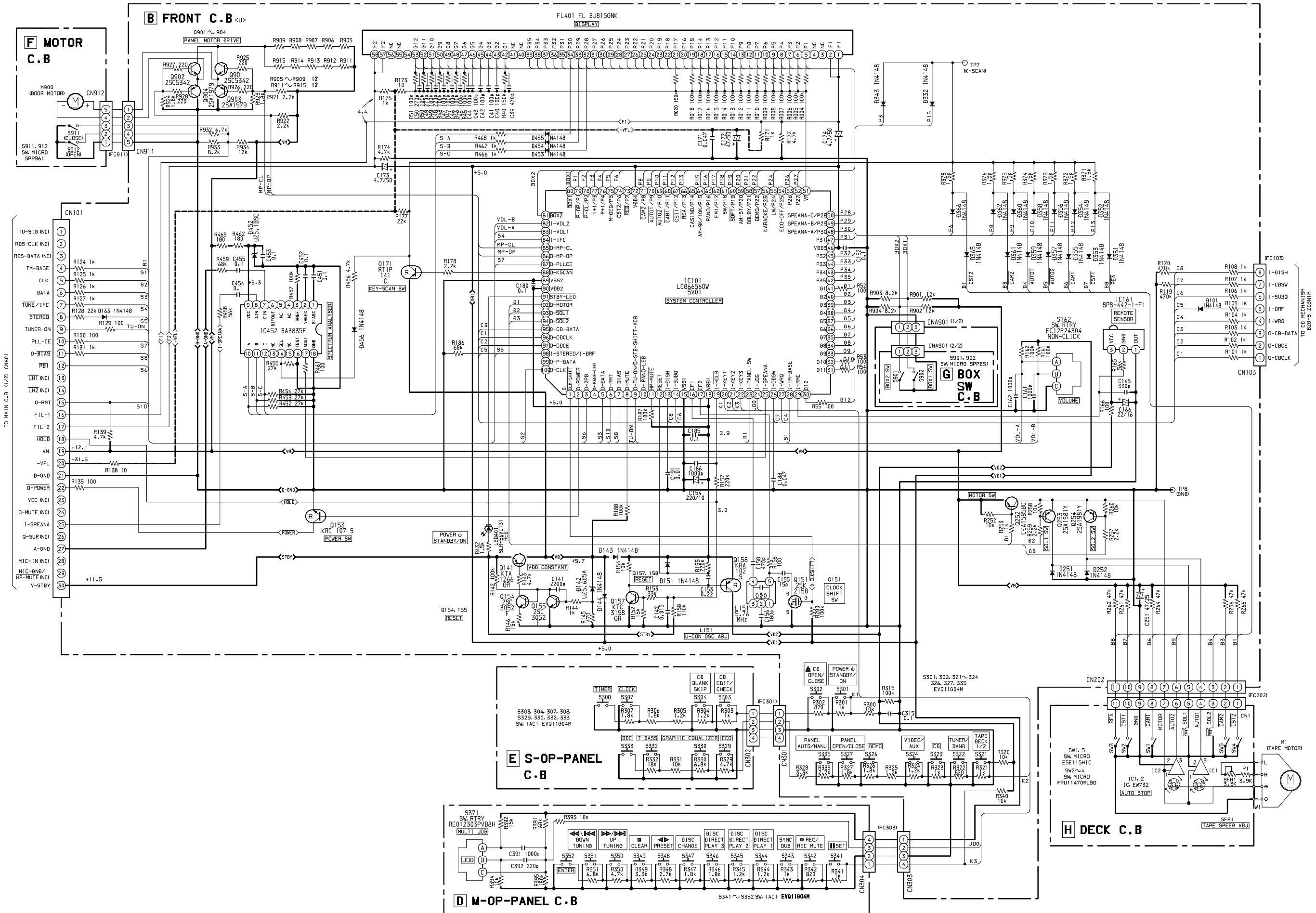

SCHEMATIC DIAGRAM - 5 (LH: FRONT / M-OP-PANEL / S-OP-PANEL / MOTOR / BOX SW / DECK)

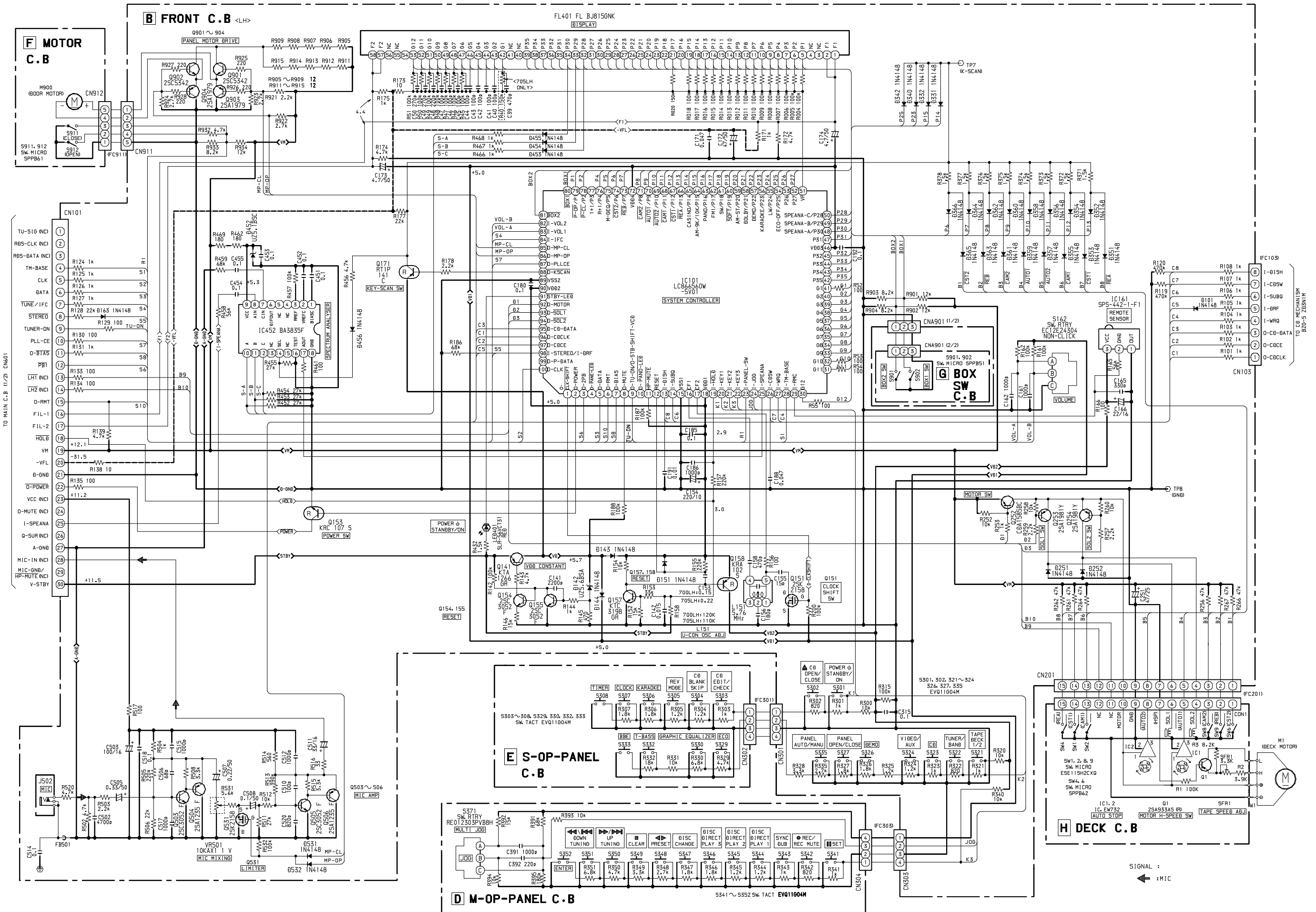

WIRING - 4 (PT) <LH>

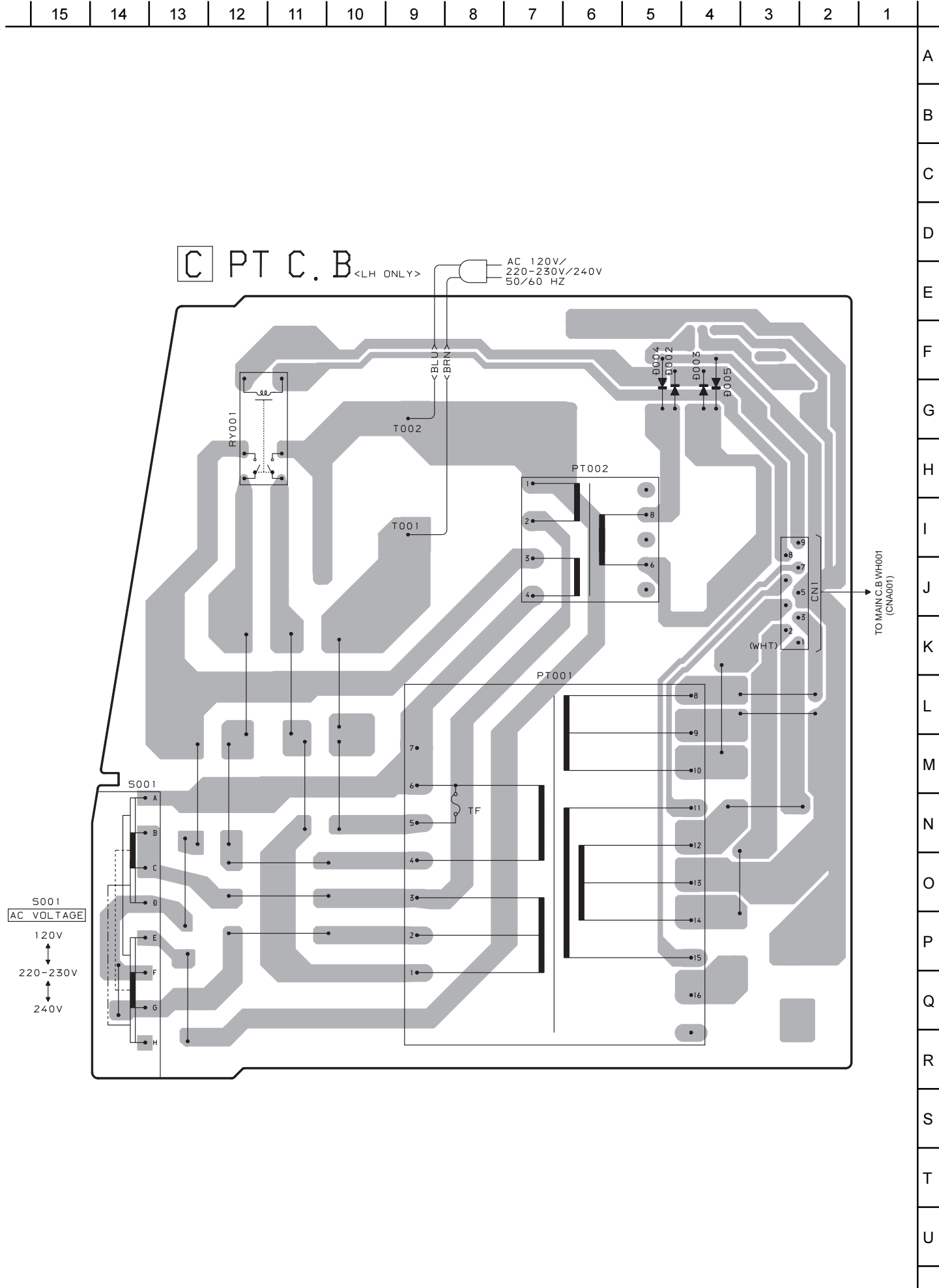

SCHEMATIC DIAGRAM-6 (PT) <LH>

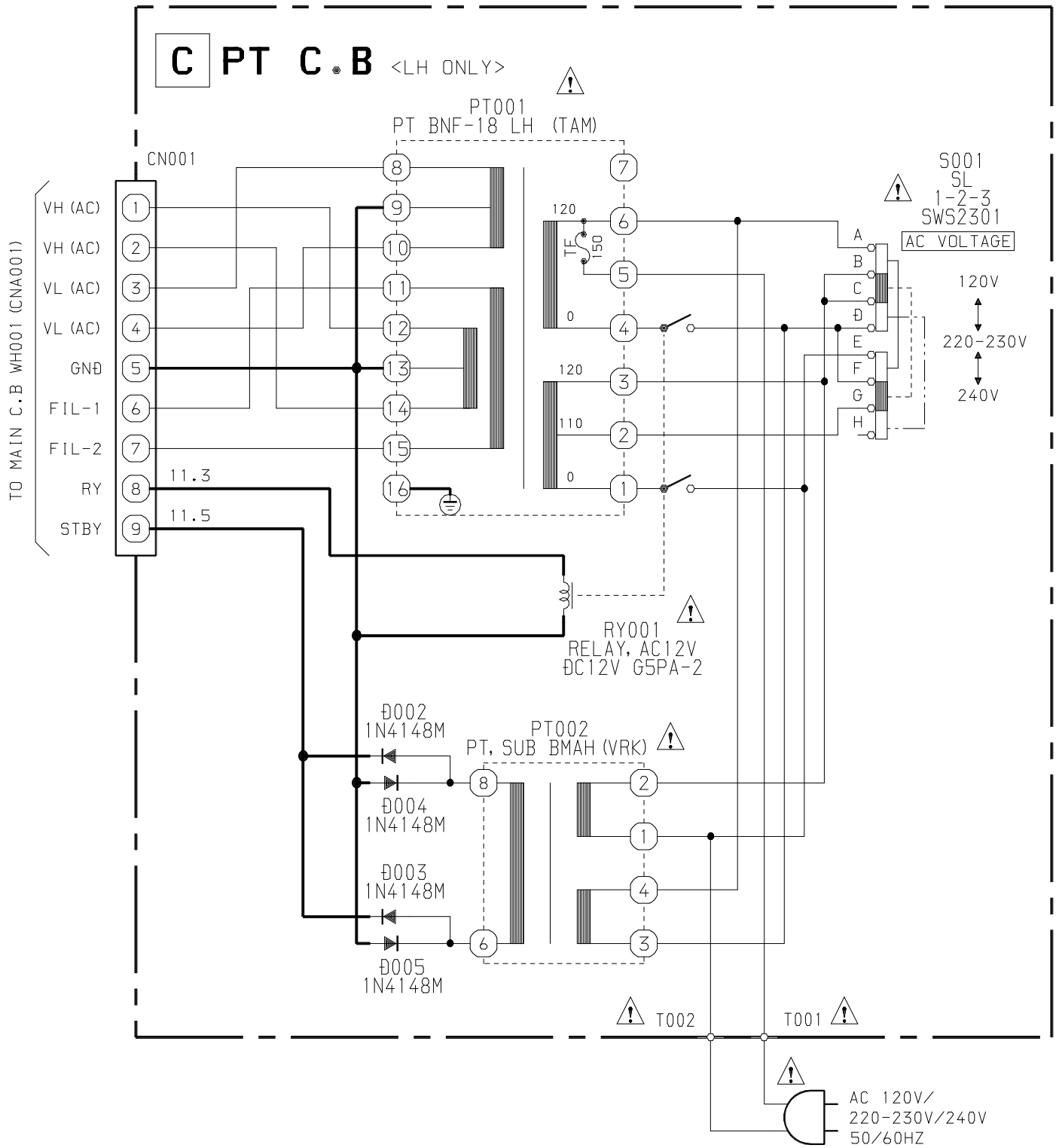

32	31	30	29	28	27	26	25	24	23	22	21	20	19	18	17	16	15	14	13	12	11	10	9	8	7	6	5	4	3	2	1
----	----	----	----	----	----	----	----	----	----	----	----	----	----	----	----	----	----	----	----	----	----	----	---	---	---	---	---	---	---	---	---

A
B
C
D
E
F
G
H
I
J
K
L
M
N
O
P
Q
R
S
T
U

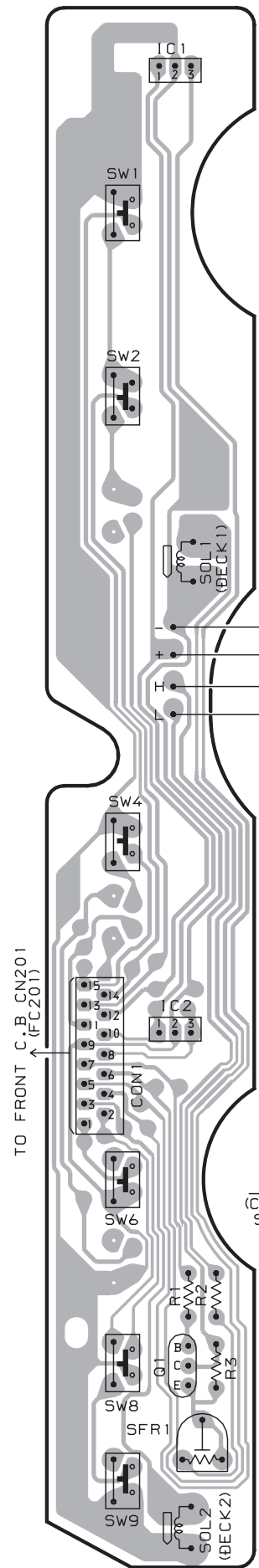

H DECK
C.B

I HEAD-1
C.B

J HEAD-2
C.B

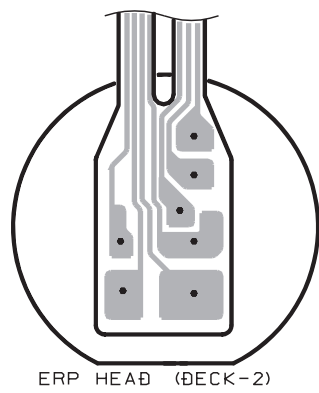
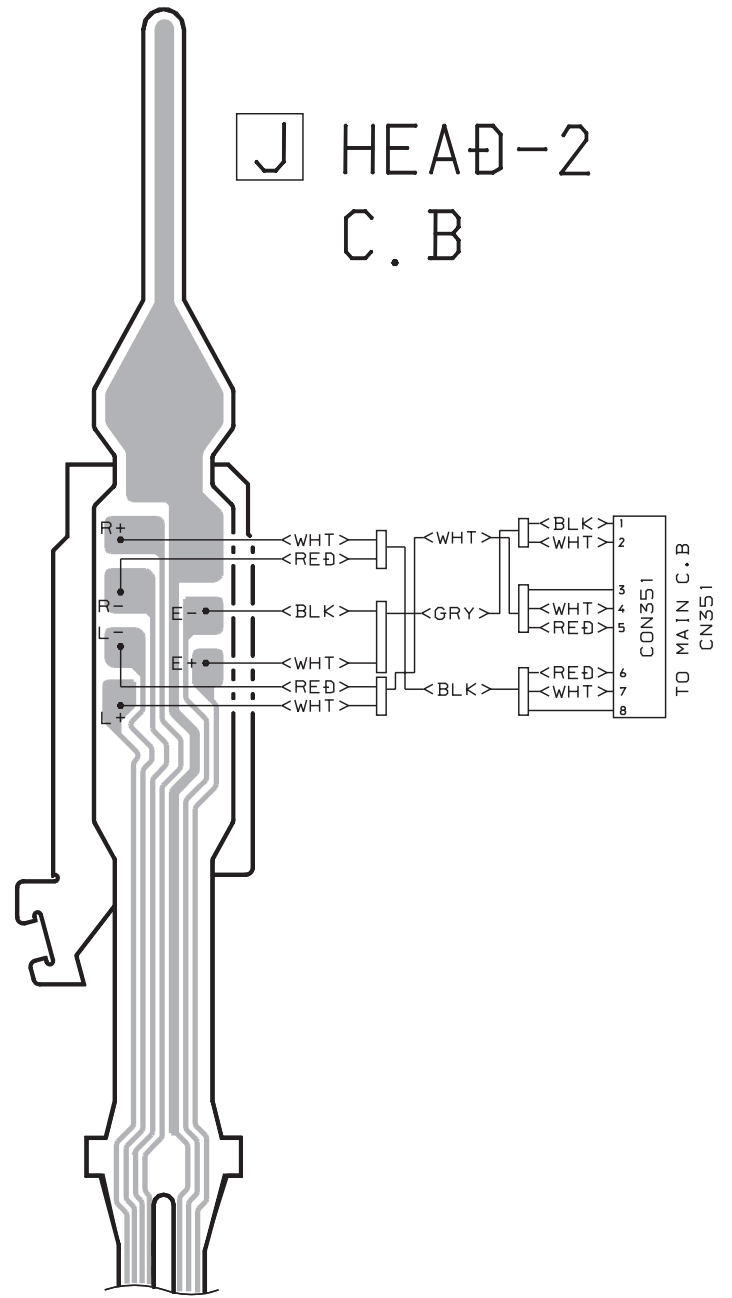
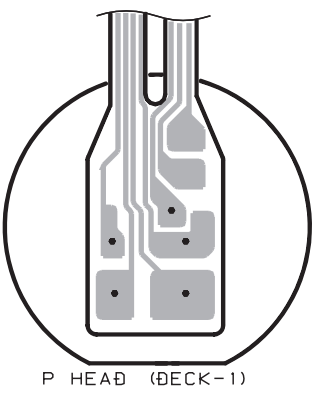
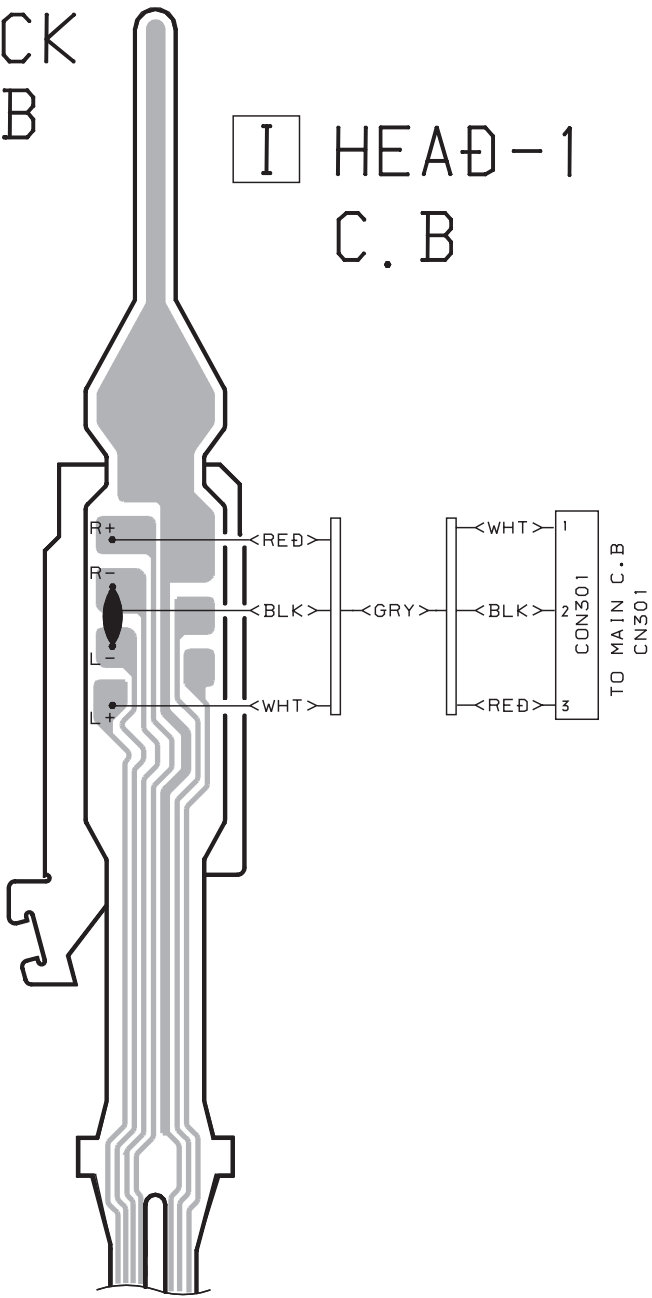

32 31 30 29 28 27 26 25 24 23 22 21 20 19 18 17 16 15 14 13 12 11 10 9 8 7 6 5 4 3 2 1

H DECK C.B

TO FRONT C.B. CN202

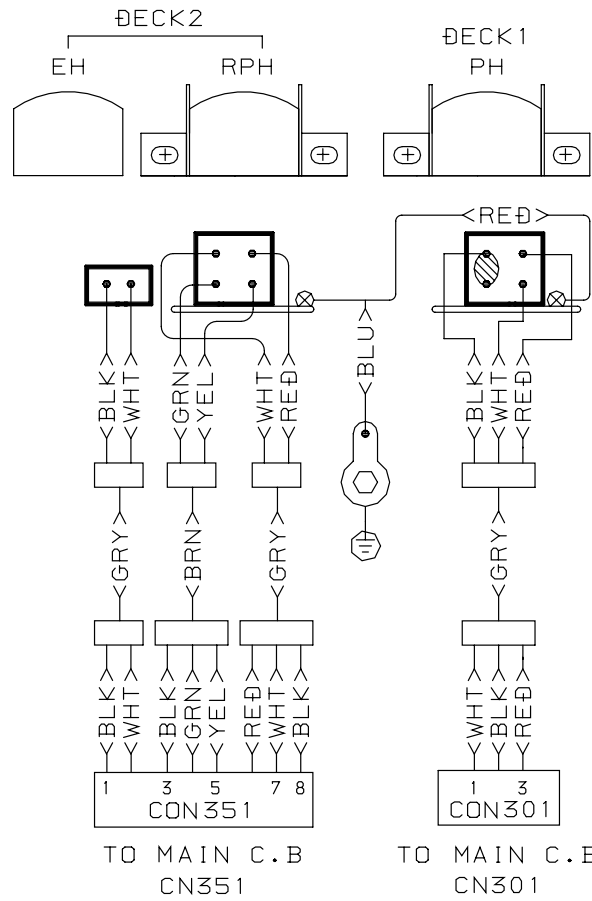
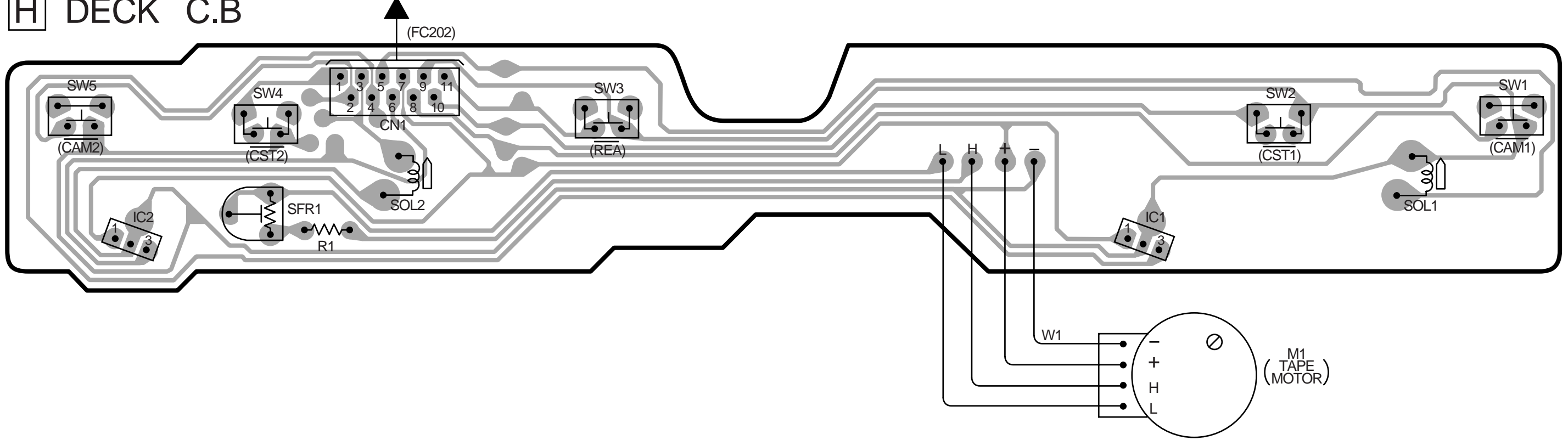

A
B
C
D
E
F
G
H
I
J
K
L
M
N
O
P
Q
R
S
T
U

FL (BJ815GNK) GRID ASSIGNMENT AND ANODE CONNECTION
 GRID ASSIGNMENT

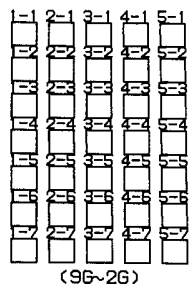
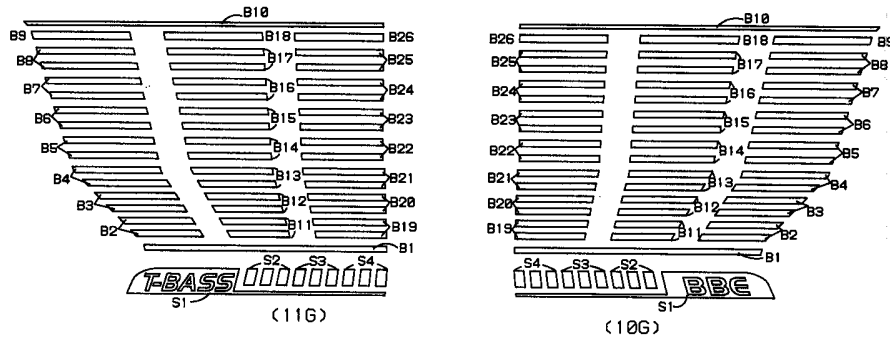
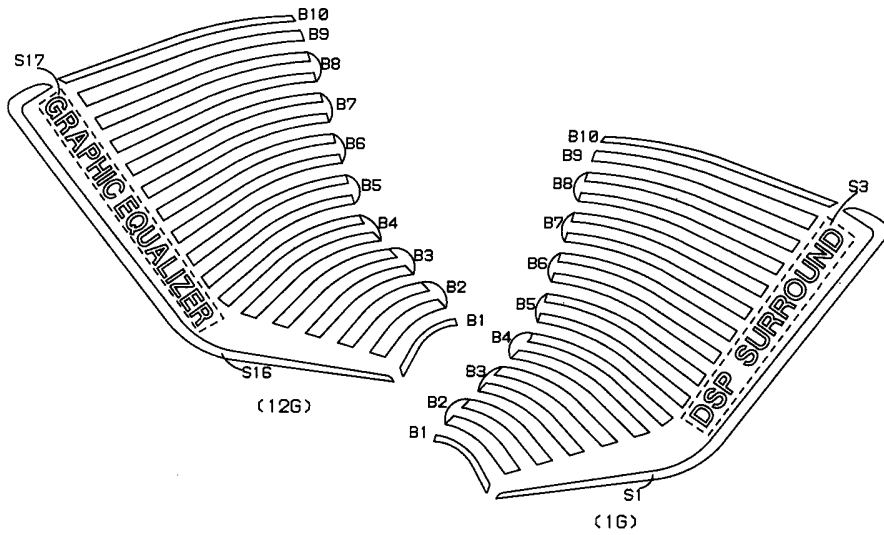
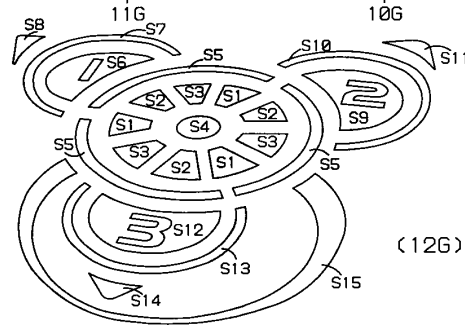
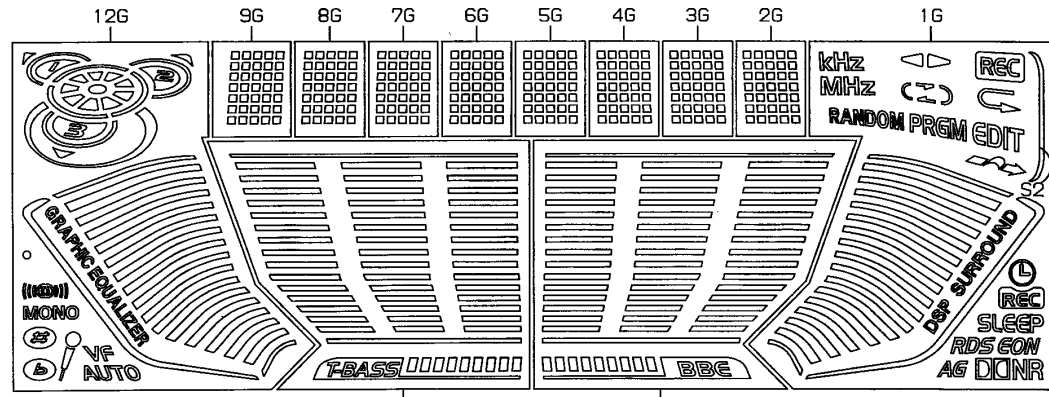

ANODE CONNECTION

	12G	11G	10G	9G~2G	1G
P1	S1	S1	S1	1-1	S1
P2	S2	S2	S2	2-1	S2
P3	S3	S3	S3	3-1	S3
P4	S4	S4	S4	4-1	
P5	S5	B1	B1	5-1	EDIT
P6	S6	-	-	1-2	
P7	S7	-	-	2-2	REC (L)
P8	S8	B2	B2	3-2	B1
P9	S9	B3	B3	4-2	B2
P10	S10	B4	B4	5-2	B3
P11	S11	B5	B5	1-3	B4
P12	S12	B6	B6	2-3	B5
P13	S13	B7	B7	3-3	B6
P14	S14	B8	B8	4-3	B7
P15	S15	B9	B9	5-3	B8
P16	○	B10	B10	1-4	B9
P17	S16	B11	B11	2-4	B10
P18	S17	B12	B12	3-4	PRGM
P19	B1	B13	B13	4-4	
P20	B2	B14	B14	5-4	
P21	B3	B15	B15	1-5	
P22	B4	B16	B16	2-5	
P23	B5	B17	B17	3-5	
P24	B6	B18	B18	4-5	RANDOM
P25	B7	B19	B19	5-5	MHz
P26	B8	B20	B20	1-6	KHz
P27	B9	B21	B21	2-6	-
P28	B10	B22	B22	3-6	-
P29	((()))	B23	B23	4-6	
P30	MONO	B24	B24	5-6	REC (F)
P31	VF	B25	B25	1-7	SLEEP
P32	AUTO	B26	B26	2-7	RDS
P33	?	-	-	3-7	EON
P34	Ⓜ	-	-	4-7	AG
P35	Ⓟ	-	-	5-7	DCNR

IC BLOCK DIAGRAM

IC, LA1845L

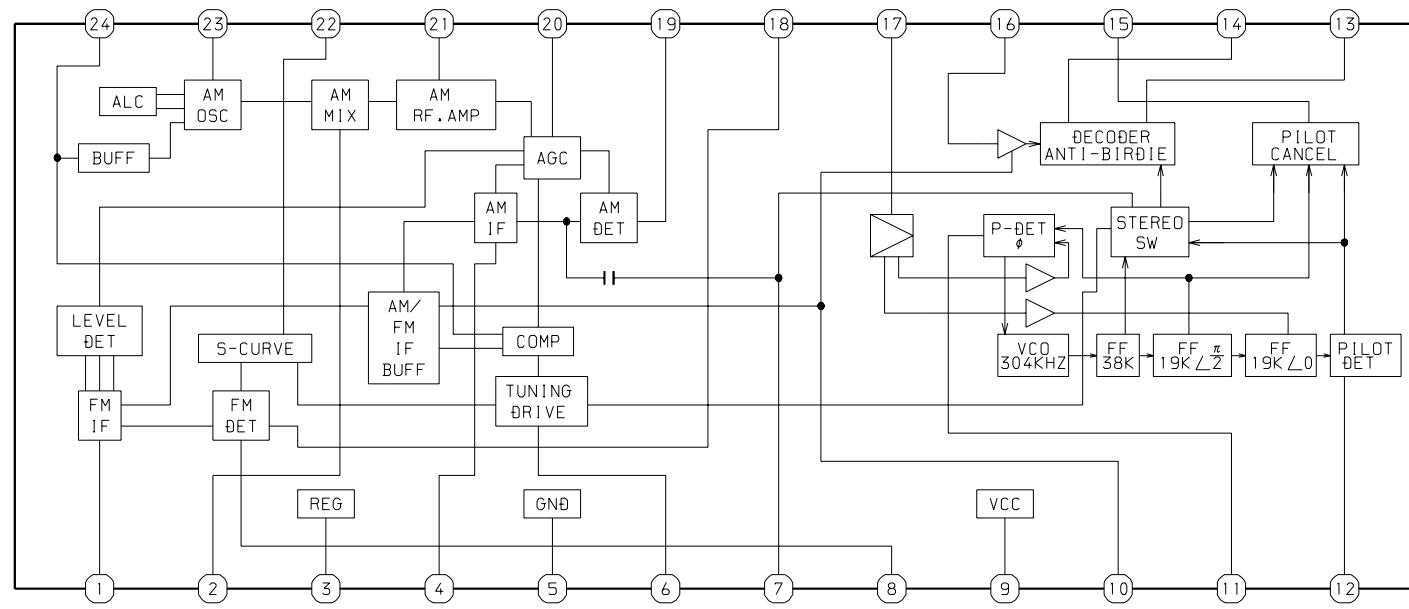

IC, BA3835F

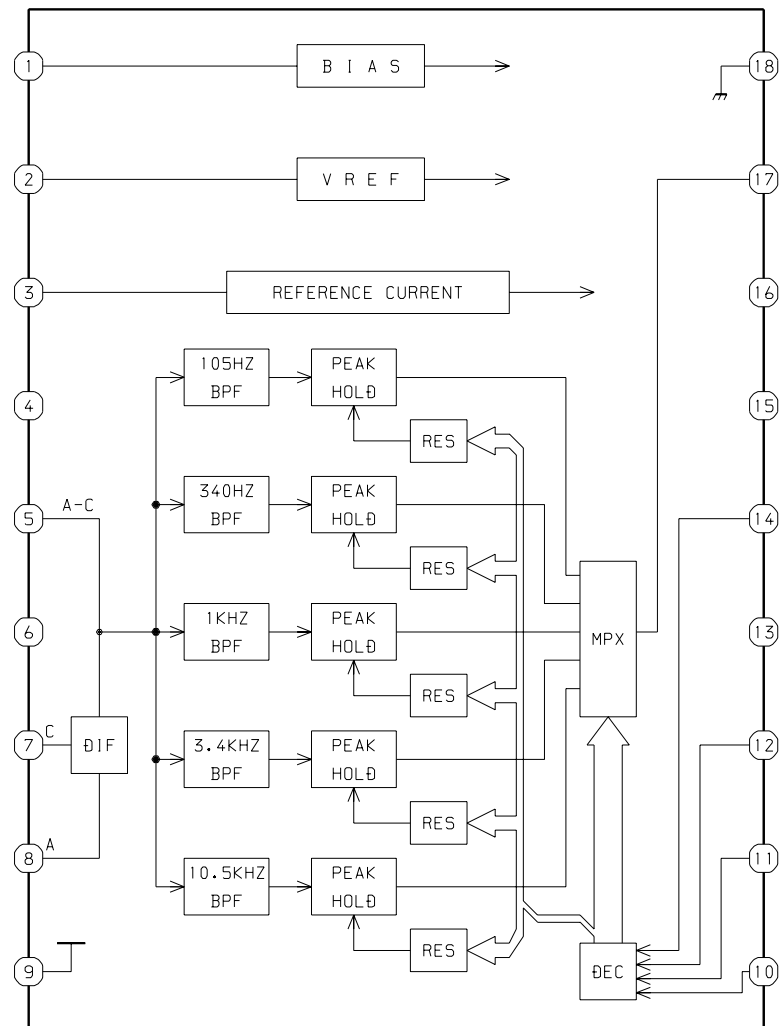

IC, LC72131D

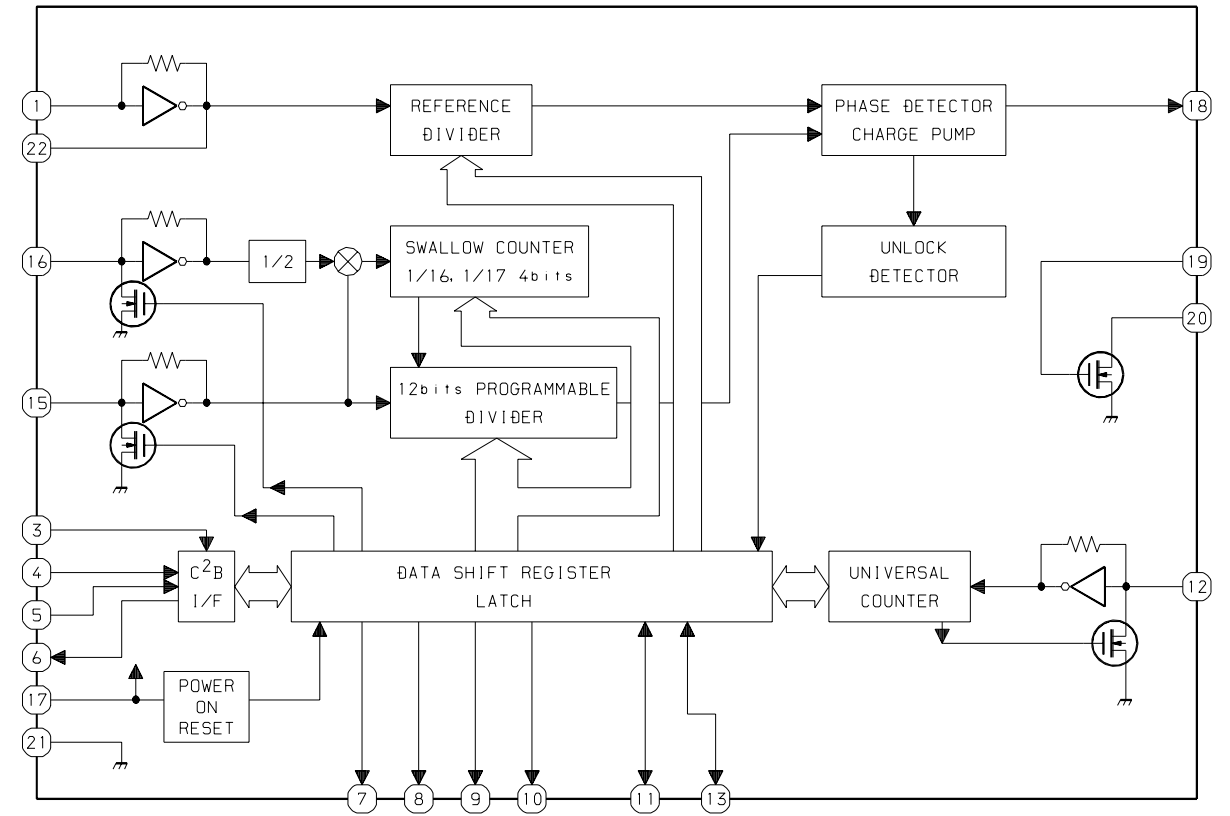

IC, M61503FP

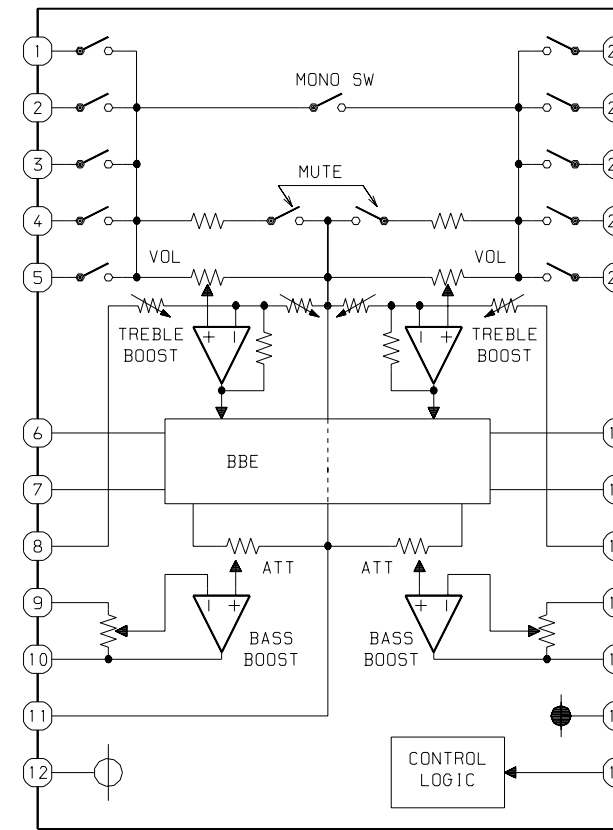

IC DESCRIPTION

IC, LC866560W-5V01

Pin No.	Pin Name	I/O	Description
1	O-C-SHIFT	O	Clock shift output for micro computer when tuner receiving broadcast.
2	O-POWER	O	Power control ON/OFF output.
3	O-2PB	O	DECK 2 / DECK 1 play output.
4	O-PANE-LED	O	Moving PANEL LED ON/OFF output (Not used).
5	O-DATA	O	Data output.
6	O-RMT	O	REC MUTE output.
7	O-BIAS	O	Bias ON/OFF output.
8	O-MUTE	O	System MUTE ON/OFF.
9	O-TU-ON/ O-STB-SHIFT-VCD	O	Tuner power supply ON/OFF output/MICON standby shift VCD output.
10	O-PANO-LED	O	Panorama LED ON/OFF output (Not used).
11	HP-MUTE	I	Head phone jack detection. "L" : MUTE
12	RESET	I	Reset input for MICON.
13	I-DISH	I	CD turnable photo sensor input.
14	I-SUBQ	I	SUB-Q data input.
15	VSS1	—	Connected to ground.
16	CF1	I	Oscillator circuit input.
17	CF2	O	Oscillator circuit output.
18	VDD1	—	Digital power supply pin.
19	I-HOLD	I	Power failure detected input.
20	I-KEY1	I	Key A/D input 1.
21	I-KEY2	I	Key A/D input 2.
22	I-KEY3	I	Key A/D input 3.
23	I-PANEL-SW	I	Panel OPEN/CLOSE detect switch AD input.
24	I-JOG	I	Dial jog rotary encoder input .
25	I-SPEANA	I	Spectrum analyser level detection.
26	I-CDSW	I	CD mehca switch input.
27	I-WRQ	I	CD WRQ input.
28	I-TM-BASE	I	Reference clock input for timer switch.
29	I-RMC	I	System remote control signal input. "L" : ACTIVE
30 ~ 41	G12 ~ G1	O	FL grid G12 ~ G1 output.
42 ~ 45	P35 ~ P32	O	FL segment P35 ~ P32 output.
46	VDD3	—	Digital power supply pin.
47	P31	O	FL segment P31 output.
48	SPEANA-A/P30	O	Spectrum analyser BPF switching control A output/FL segment P30 output.
49	SPEANA-B/P29	O	Spectrum analyser BPF switching control B output/FL segment P29 output.
50	SPEANA-C/P28	O	Spectrum analyser BPF switching control C output/FL segment P28 output.
51	VP	—	Power supply for FL.
52 ~ 53	P27 ~ P26	O	FL segment P27 ~ P26 output.
54	ECO-OFF/P25	I/O	ECO-OFF data input<LH only>/FL segment P25 output.
55	LW/P24	I/O	LW diode input (Not used)/FL segment P24 output.

Pin No.	Pin Name	I/O	Description
56	KARAOKE/P23	I/O	Karaoke input to diode<LH only>/FL segment P23 output.
57	DEMO/P22	I/O	Demo (on the stop) diode input (Not used)/FL segment P22 output.
58	DOLBY/P21	I/O	DECK DOLBY diode input (Not used)/FL segment P21 output.
59	AM-ST/P20	I/O	AM-ST select diode (Not used)/FL segment P20 output.
60	SOFT/P19	I/O	DECK SOFT diode input (Not used)/FL segment P19 output.
61	SW/P18	I/O	SW diode input (Not used)/FL segment P18 output.
62	FM1/P17	I/O	FM1 diode input (Not used)/FL segment P17 output.
63	PANO/P16	I/O	Panorama diode input (Not used)/FL segment P16 output.
64	AM-9K/10K/P15	I/O	AM-9K/10K select diode input/FL segment P15 output.
65	CASINO/P14	I/O	Initial casino diode input<LH only>/FL segment P14 output.
66	RE \bar{A} /P13	I/O	DECK2 side A recordable switch. "L" : REC/FL segment P13 output.
67	CST1/P12	I/O	DECK1 cassette detection switch data input. "L" : ON/FL segment P12 output.
68	CAM1/P11	I/O	DECK1 CAM STOP switch data input. "L" : ON/FL segment P11 output.
69	AUTO2/P10	I/O	DECK2 AUTO STOP switch data input/FL segment P10 output.
70	AUTO1/P9	I/O	DECK1 AUTO STOP switch data input/FL segment P9 output.
71	CAM2/P8	I/O	DECK2 CAM switch data input. "L" : ON/FL segment P8 output.
72	VDD4	—	Digital power supply pin.
73	RE \bar{B} /P7	I/O	DECK2 side B recordable switch. "L" : REC<LH only>/FL segment P7 output.
74	CST2/P6	I/O	DECK2 cassette detection switch data input. "L" : ON/FL segment P6 output.
75	M-GEO/P5	I/O	Manual GEQ diode input (Not used)/FL segment P5 output.
76	R+1/P4	I/O	DECK R+1 diode input (Not used)/FL segment P4 output.
77	1+1/P3	I/O	DECK 1+1 diode input<U only>/FL segment P3 output.
78	P- $\bar{C}L$ /P2	I/O	(Not used)/FL segment P2 output.
79	P- $\bar{O}P$ /P1	I/O	(Not used)/FL segment P1 output.
80	BOX1	I	Cassette BOX1 open/close detect input.
81	BOX2	I	Cassette BOX1 open/close detect input.
82	I-VOL2	I	Volume rotary encoder input 2.
83	I-VOL1	I	Volume rotary encoder input 1.
84	I-IFC	I	Tuner IF count input.
85	O-MP-CL	O	Moving panel close output.
86	O-MP-OP	O	Moving panel open output.
87	O-PLL CE	O	Tuner PLL IC chip enable output.
88	O-KSCAN	O	Initial scan output.
89	VSS2	—	Connected to ground.
90	VDD2	—	Digital power supply pin.
91	STBY-LED	O	Standby LED ON/OFF output. "L" : ON
92	O-MOTOR	O	Cassette deck motor control output.
93	O-SOL1	O	DECK1 solenoid output.
94	O-SOL2	O	DECK2 solenoid output.
95	O-CD DATA	O	CD IC control data output.
96	O-CD CLK	O	CD IC control clock output.

Pin No.	Pin Name	I/O	Description
97	O-CD CE	O	CD data chip enable output.
98	I-STEREO/I-DRF	I	Tuner stereo detect input/RF (radio frequency) detect.
99	O-P-DATA	O	Panorama IC data output (Not used).
100	O-CLK	O	PLL IC clock output.

ADJUSTMENT <TUNER / DECK / FRONT>

< TUNER SECTION >

1. Clock Frequency Check
Settings : • Test point : TP2 (CLK)
Method : Set to AM 1710kHz and check that the test point is 2160kHz \pm 45Hz.
2. AM VT Check
Settings : • Test point : TP1 (VT)
Method : Set to AM 1710kHz and check that the test point is less than 8.5V. Then set to AM 530kHz and check that the test point is more than 0.6V.
3. AM Tracking Adjustment
Settings : • Test point : TP5 (Lch), TP6 (Rch)
• Adjustment location : L951(1/3)
Method : Set to AM 1000kHz and adjust L951(1/3) so that the test point becomes maximum.
4. FM VT Adjustment
Settings : • Test point : TP1 (VT)
• Adjustment location : L906
Method : Set to FM 108.0MHz and adjust L906 so that the test point becomes 7.0V \pm 0.1V.
5. FM Tracking Adjustment
Settings : • Test point : TP5(Lch), TP6(Rch)
• Adjustment location : L903
Method : Set to FM 87.5 MHz and adjust L903 so that the test point is less than 9.0dB μ V.
6. AM IF Adjustment
Settings : • Test point : TP5(Lch), TP6(Rch)
• Adjustment location : L802.....450kHz
7. DC Balance / Mono Distortion Adjustment
Settings : • Test point : TP3, TP4 (DC Balance)
: TP5 (Lch), TP6 (Rch) (Distortion)
• Adjustment location : L801
• Input level : 60dB μ V
Method : Set to FM 98.0MHz and adjust L801 so that the voltage between TP3 and TP4 becomes 0V \pm 300mV.
Then check that the distortion is less than 1.2%

< DECK SECTION >

1. Tape Speed Adjustment (DECK 2)
Settings : • Test tape : TTA-100
• Test point : TP5 (Lch), TP6 (Rch)
• Adjustment location : SFR1
Method : Play back the test tape and adjust SFR1 so that the frequency counter reads 3000Hz \pm 5Hz (FWD) and \pm 45Hz (REV) with respect to forward speed.
2. Head Azimuth Adjustment (DECK 1, DECK 2)
Settings : • Test tape : TTA-300
• Test point : TP5 (Lch), TP6 (Rch)
• Adjustment location : Head azimuth adjustment screw
Method : Play back (FWD) the 8kHz signal of the test tape and adjust screw so that the output becomes maximum.
Next, perform on REV PLAY mode.

3. PB Frequency Response Check (DECK 1, DECK 2)
Settings : • Test tape : TTA-330
• Test point : TP5(Lch), TP6(Rch)
Method : Play back the 315Hz and 8kHz signals of the test tape and check that the output ratio of the 10kHz signal with respect to that of the 315Hz signal is 0dB \pm 5dB.
4. REC/PB Frequency Response Adjustment (DECK 2)
Settings : • Test tape : TTA-602
• Test point : TP5(Lch), TP6(Rch)
• Adjustment location : SFR451(Lch)
SFR452(Rch)
Method : Apply a 1kHz signal and REC mode. Then adjust OSC attenuator so that the output level at the TP5, TP6 becomes 10mV. Record and play back the 1kHz and 8kHz signal and adjust SFRs so that the output of the 8kHz signals is 0dB \pm 1dB with respect to that of the 1kHz signal.
5. REC/PB Sensitivity Check (DECK 2)
Settings : • Test tape : TTA-602
• Test point : TP5(Lch), TP6(Rch)
• Input signal : 1kHz (LINE IN)
Method : Apply a 1kHz signal and REC mode. Then adjust OSC attenuator so that the output level at TP5, TP6 becomes 80mV. Record and play back the 1kHz signals and check that the output is -1dB \pm 3.5dB.
6. PB Sensitivity Check (DECK 1, DECK 2)
Settings : • Test tape : TTA-200
• Test point : TP5 (Lch), TP6 (Rch)
Method : Play back the test tape and check that the output level of the test point is 110mV \pm 3dB.

< FRONT SECTION >

1. μ -CON OSC Adjustment
Settings : • Test point : TP7 (K-SCAN) and TP8 (GND)
• Adjustment location : L151
Method : Insert AC plug while pressing tuner function key and power key. Adjust L151 so that the frequency at the test point is 141.67Hz \pm 0.14Hz.

CD TEST MODE

1. How to Start the CD Test Mode

While pressing the FUNCTION button, insert the AC plug to the power outlet.
When the test mode is started, the message [CD TEST] is displayed.

2. How to Exit the CD Test Mode

Press the POWER button or disconnect the AC plug.

* When any key other than PLAY is pressed during play mode, the machine exits the test mode.

3. Function Descriptions and Application of the CD Test Mode

No	Mode	Operation	Display	Function	Checking item
1	Start mode		All indicators light	<ul style="list-style-type: none"> All FL indicators light 	<ul style="list-style-type: none"> FL check Microprocessor check
2	Search mode	STOP button	READING	<ul style="list-style-type: none"> LD illuminates all the time Focus search continuous operations *1 Spindle motor continuous kick 	<ul style="list-style-type: none"> APC circuit check Laser current measurement Focus search waveform check Focus error waveform check (DRF in the search mode is ignored)
3	Play mode	Play button	Normal	<ul style="list-style-type: none"> Normal playback If TOC cannot be read, focus search is continued 	<ul style="list-style-type: none"> Each servo circuit is checked DRF check
4	Traverse mode	PAUSE button	Normal	<ul style="list-style-type: none"> Tracking servo OFF/ON Each time PAUSE button is pressed, the tracking servo repeats turning OFF/ON 	<ul style="list-style-type: none"> Tracking balance check
5	Sled mode	FF button	CD TEST	<ul style="list-style-type: none"> Pickup moves to the inner circumference *2 At the same time, lens kicks to the inner circumference 	<ul style="list-style-type: none"> Sled circuit check Tracking circuit check Mechanism operation check Pickup check
		RWD button	CD TEST	<ul style="list-style-type: none"> Pickup moves to the outer circumference *2 At the same time, lens kicks to the outer circumference 	
6	Spindle mode	REC/REC MUTE button	All indicators light	<ul style="list-style-type: none"> The spindle motor rotates forward (rough speed) by pressing the button and rotates backward by pressing one more time and stops by pressing again 	<ul style="list-style-type: none"> Spindle circuit Spindle motor

*1: The driver IC heats up and the protection circuit starts working when the focus search is continued for 10 minutes or longer. There can be a case that operations can not be performed correctly.
In such a case, turn off the main power. After cooling down the machine, restart the machine.

*2: Be careful not to damage the gear because the sled motor rotates while the FF or RWD button is being pressed even if the pick-up is located in the innermost track or the outermost track.

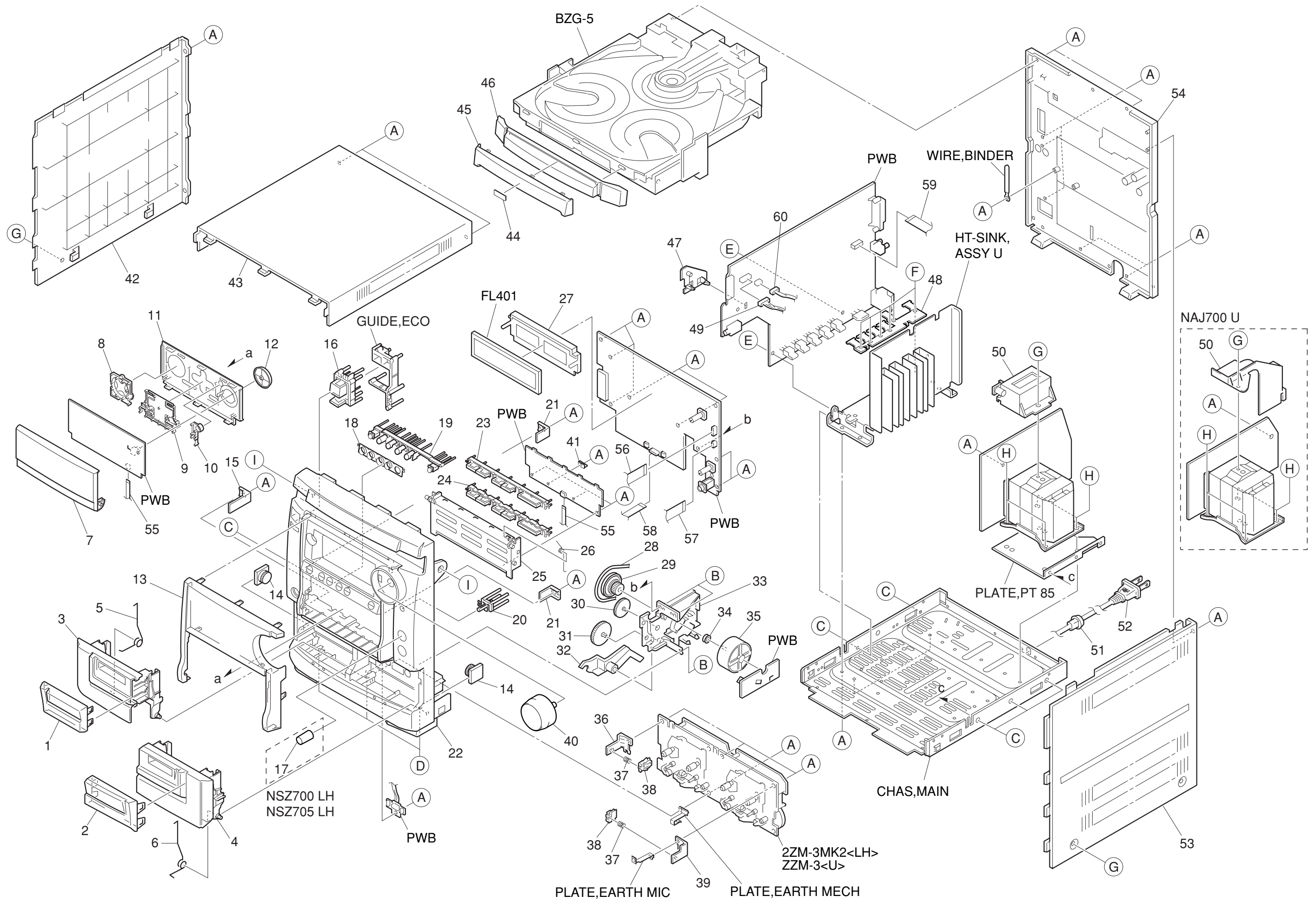

MECHANICAL PARTS LIST 1 / 1

REF. NO.	PART NO.	KANRI NO.	DESCRIPTION	REF. NO.	PART NO.	KANRI NO.	DESCRIPTION
1	8B-NF7-007-010		WINDOW,CASS 1	36	87-NF4-216-010		HLDR,LOCK 1
2	8B-NF7-008-010		WINDOW,CASS 2	37	86-NF9-224-010		SPR-C,LOCK
3	8B-NF7-041-010		BOX,CASS 1 1WAY<U>	38	82-NF5-229-010		PLATE,LOCK
3	8B-NF7-003-010		BOX,CASS 1 REV<EXCEPT U>	39	87-NF4-217-110		HLDR,LOCK 2
4	8B-NF7-042-010		BOX,CASS 2 1WAY<U>	40	8B-NF7-012-010		KNOB,RTRY VOL
4	8B-NF7-004-010		BOX,CASS 2 REV<EXCEPT U>	41	8B-NF7-222-010		HLDR,STOP
5	8A-NF8-281-010		SPR-T,EJECT 1	42	8A-NF8-007-010		PANEL,LEFT V-2
6	8A-NF8-282-010		SPR-T,EJECT 2	43	8B-NF7-039-010		PANEL,TOP V-2 BNFK
7	8B-NFJ-002-010		PANEL,MOVE 1F H<700 LH>	44	87-CE3-023-010		BADGE,AIWA 30N SILV
7	8B-NFJ-016-010		PANEL,MOVE 1F H 705<705 LH>	45	8B-NF7-035-010		WINDOW,TRAY
7	8B-NFJ-001-010		PANEL,MOVE 1F U<U>	46	8B-NF7-005-010		PANEL,TRAY
8	8B-NF7-030-010		KEY,CD	47	8A-NF8-206-010		HLDR,PWB M
9	8B-NF7-050-010		KEY,ASSY OPE 1WAY<U>	48	8B-NF7-239-010		HLDR,TR U<EXCEPT U>
9	8B-NF7-022-010		KEY,ASSY OPE REV<EXCEPT U>	48	8B-NF7-239-010		HLDR,TR U<U>
10	8B-NF7-031-010		KEY,ENTER	49	87-NF6-616-010		CONN ASSY,8P RPB<EXCEPT U>
11	8B-NF7-044-010		PANEL,MOVE 1R EZ<U>	50	8B-NF7-208-010		HLDR,PT(76-60)<U>
11	8B-NF7-045-010		PANEL,MOVE 1R H<EXCEPT U>	50	8A-DB8-209-010		HLDR,PWB PT<EXCEPT U>
12	8B-NF7-013-010		KNOB,RTRY JOG	51	87-085-185-010		BUSHING, AC CORD (E)<EXCEPT U>
13	8B-NF7-067-010		WINDOW,DISP H<700 LH>	51	87-A91-422-010		BUSHING,AC CORD(U)<U>
13	8B-NFJ-021-010		WINDOW,DISP U<EXCEPT 700 LH>	52	87-A80-157-010		AC CORD ASSY,E BLK CC<EXCEPT U>
14	8Z-NF6-210-010		DMPR,150 N	52	87-A80-149-010		AC CORD ASSY,U BLK<U>
15	8B-NF7-221-010		HLDR,PANEL	53	8A-NF8-008-010		PANEL,RIGHT V-2
16	8B-NF7-015-010		KEY,ASSY POWER	54	8B-NFJ-032-010		CABI,REAR LHSM<NSZ700 LH>
17	8B-NF7-014-010		KNOB,RTRY MIC<EXCEPT U>	54	8B-NFJ-040-010		CABI,REAR LHSM 705<NSZ705 LH>
18	8B-NFJ-010-010		RING,FUN 4	54	8B-NFJ-031-010		CABI,REAR USM<U>
19	8B-NFJ-007-010		KEY,ASSY FUN 4	55	88-904-091-110		FF-CABLE,4P 1.25 90MM
20	8B-NF7-037-010		KEY,PANEL	56	88-908-301-110		FF-CABLE,8P 1.25
21	8B-NF7-223-010		HLDR,PANEL 2	57	88-905-151-110		FF-CABLE, 5P 1.25 150MM
22	8B-NFJ-012-010		CABI,FR H<EXCEPT U>	58	88-915-101-110		FF-CABLE, 15P 1.25 100MM<EXCEPT U>
22	8B-NFJ-011-010		CABI,FR U<U>	58	88-911-101-110		FF-CABLE,11P 1.25<U>
23	8B-NF7-029-010		KEY,BBE	59	88-906-251-110		FF-CABLE,6P 1.25(RVS-FACE)
24	8B-NF7-055-010		KEY,TIMER H<EXCEPT U>	60	87-NF6-615-010		CONN ASSY,3P PB<EXCEPT U>
24	8B-NF7-032-010		KEY,TIMER U<U>	A	87-067-703-010		TAPPING SCREW, BVT2+3-10
25	8B-NFJ-026-010		PANEL,MOVE 2H<EXCEPT U>	B	87-067-758-010		BVT2+3-12 W/O SLOT
25	8B-NF7-011-010		PANEL,MOVE 2U<U>	C	87-721-096-410		QT2+3-10 GLD
26	8B-NF7-220-010		SPR-T,OPEN	D	87-067-688-010		BVTT+3-6
27	8A-NF6-201-010		GUIDE,FL	E	87-NF4-224-010		S-SCREW,IT3B+3-8 CU
28	8B-NF7-214-010		BELT,SQ 1.8-113.5	F	87-067-579-010		TAPPING SCREW, BVT2+3-8
29	8B-NF7-213-010		PULLEY,RELAY	G	87-067-641-010		UTT2+3-8(W/O SLOT)BL
30	8B-NF7-212-010		GEAR,RELAY	H	87-078-199-010		S-SCREW,ITC+4-10 R<EXCEPT U>
31	8B-NF7-211-010		GEAR,PANEL	H	87-078-200-010		S-SCREW,ITC+4-8 R<U>
32	8B-NF7-217-010		LEVER,SW	I	87-721-097-410		QT2+3-12 GLD
33	8B-NF7-210-010		HLDR,MECHA				
34	84-2G1-267-010		PULLEY,LOAD MO 8				
35	87-045-305-010		MOTOR, RF-500TB DC-5V (2MA)				

COLOR NAME TABLE

Basic color symbol	Color	Basic color symbol	Color	Basic color symbol	Color
B	Black	C	Cream	D	Orange
G	Green	H	Gray	L	Blue
LT	Transparent Blue	N	Gold	P	Pink
R	Red	S	Silver	ST	Titan Silver
T	Brown	V	Violet	W	White
WT	Transparent White	Y	Yellow	YT	Transparent Yellow
LM	Metallic Blue	LL	Light Blue	GT	Transparent Green
LD	Dark Blue	DT	Transparent Orange	GM	Metallic Green
YM	Metallic Yellow	DM	Metallic Orange	PT	Transparent Pink
LA	Aqua Blue	GL	Light Green	HT	Transparent Gray

TAPE MECHANISM EXPLODED VIEW 1/1 <U>

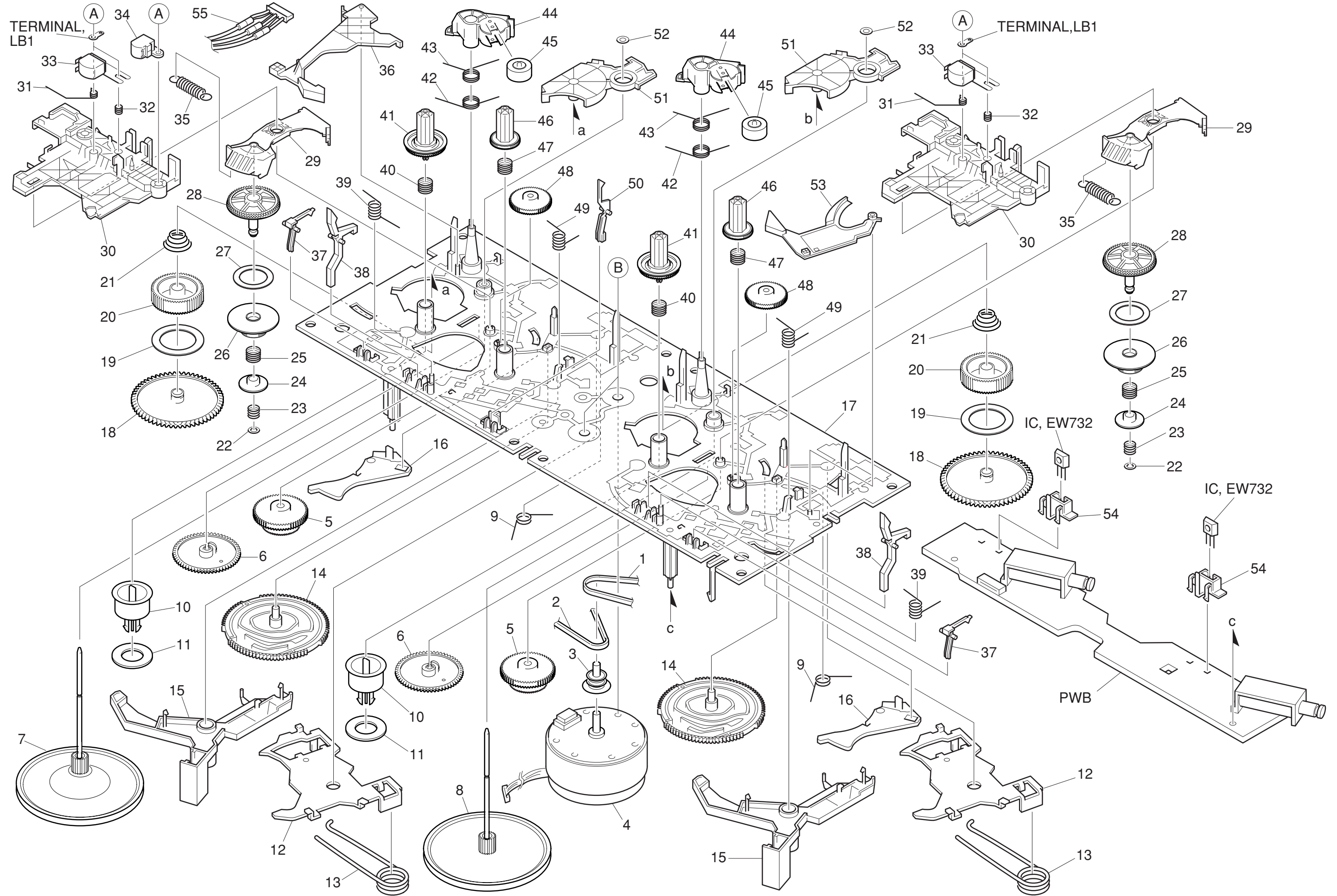

TAPE MECHANISM PARTS LIST 1 / 1 <U>

REF. NO.	PART NO.	KANRI NO.	DESCRIPTION	REF. NO.	PART NO.	KANRI NO.	DESCRIPTION
1	8Z-ZM3-227-010		BELT, MAIN M3	31	8Z-ZM3-233-010		SPR-T, BRG M3
2	8Z-ZM3-235-010		BELT, MAIN L	32	84-ZM2-227-310		SPR-C, AZIMUTH
3	8Z-ZM1-235-010		PULLEY, MOT	33	87-A90-403-110		HEAD, RPH MS15R
4	87-045-347-010		MOT, SHU2L 70	34	87-A90-404-010		HEAD, EH LE15B
5	8Z-ZM1-232-010		GEAR, IDL FF/REW	35	8Z-ZM3-239-010		SPR-E, FR
6	8Z-ZM3-244-010		GEAR, CAM TD20	36	8Z-ZM3-211-010		LEVER, EJECT R
7	8Z-ZM3-256-010		FLY-WHL ASSY, M3 R	37	8Z-ZM3-225-010		LEVER, STOP
8	8Z-ZM3-255-010		FLY-WHL ASSY, M3 L	38	8Z-ZM3-221-010		LEVER, CAS
9	8Z-ZM3-231-010		SPR-T, TRIG	39	8Z-ZM3-234-010		SPR-T, LVR CAS
10	8Z-ZM3-213-010		CLR, MG	40	8Z-ZM3-223-010		SPR-C, REEL R M3
11	82-ZM3-616-010		RING MAGNET 4	41	8Z-ZM1-225-110		GEAR, REEL R
12	8Z-ZM3-243-010		LEVER ASSY, HD UP	42	8Z-ZM3-240-010		SPR-T, T-UP M3
13	8Z-ZM3-238-010		SPR-T, HD UP	43	8Z-ZM3-237-010		SPR-T, PINCH M3
14	8Z-ZM3-219-010		GEAR, CAM M3	44	8Z-ZM3-215-010		LEVER, PINCH M3
15	8Z-ZM3-206-010		LEVER, TRIG	45	8Z-ZM1-261-110		ROLLER ASSY, PINCH
16	8Z-ZM3-209-010		LEVER, CAM FR	46	8Z-ZM1-226-010		GEAR, REEL L
17	8Z-ZM3-203-010		CHAS ASSY, M3	47	8Z-ZM3-222-010		SPR-C, REEL L M3
18	8Z-ZM1-228-010		GEAR, SLIP T-UP B	48	8Z-ZM3-251-010		GEAR, IDL REW M3
19	8Z-ZM1-265-010		FELT, T-UP	49	8Z-ZM3-236-010		SPR-T, PLAY M3
20	8Z-ZM1-227-010		GEAR, SLIP T-UP A	50	82-ZM1-240-110		LVR, REC (*)
21	8Z-ZM1-251-110		SPR-C, T-UP SLIP	51	8Z-ZM3-216-010		LEVER, T-UP M3
22	8Z-ZM1-275-010		W-L, 1, 47-4-0.25	52	87-B10-301-010		W-L, 1.63-3.2-05 SLIT
23	8Z-ZM1-257-010		SPR-C, F/R	53	8Z-ZM3-212-010		LEVER, EJECT L
24	8Z-ZM1-236-010		CLR, SLIP FF/REW	54	8Z-ZM3-214-010		HLDR, IC
25	8Z-ZM3-226-010		SPR-C, FR M3	55	86-ZM3-605-110		CONN ASSY, 8P -RPB
26	8Z-ZM3-250-010		GEAR, SLIP F/R A M3	A	84-ZM2-242-010		S-SCREW, AZ1-2-6.4
27	8Z-ZM1-269-010		FELT, FF/REW 2	B	8Z-ZM2-220-110		V+2.6 ZZM-2
28	8Z-ZM1-238-110		GEAR, SLIP FF/REW B 2				
29	8Z-ZM3-220-010		LEVER, FR M3				
30	8Z-ZM3-205-010		LEVER, PLAY M3				

TAPE MECHANISM EXPLODED VIEW 1 / 1 <LH>

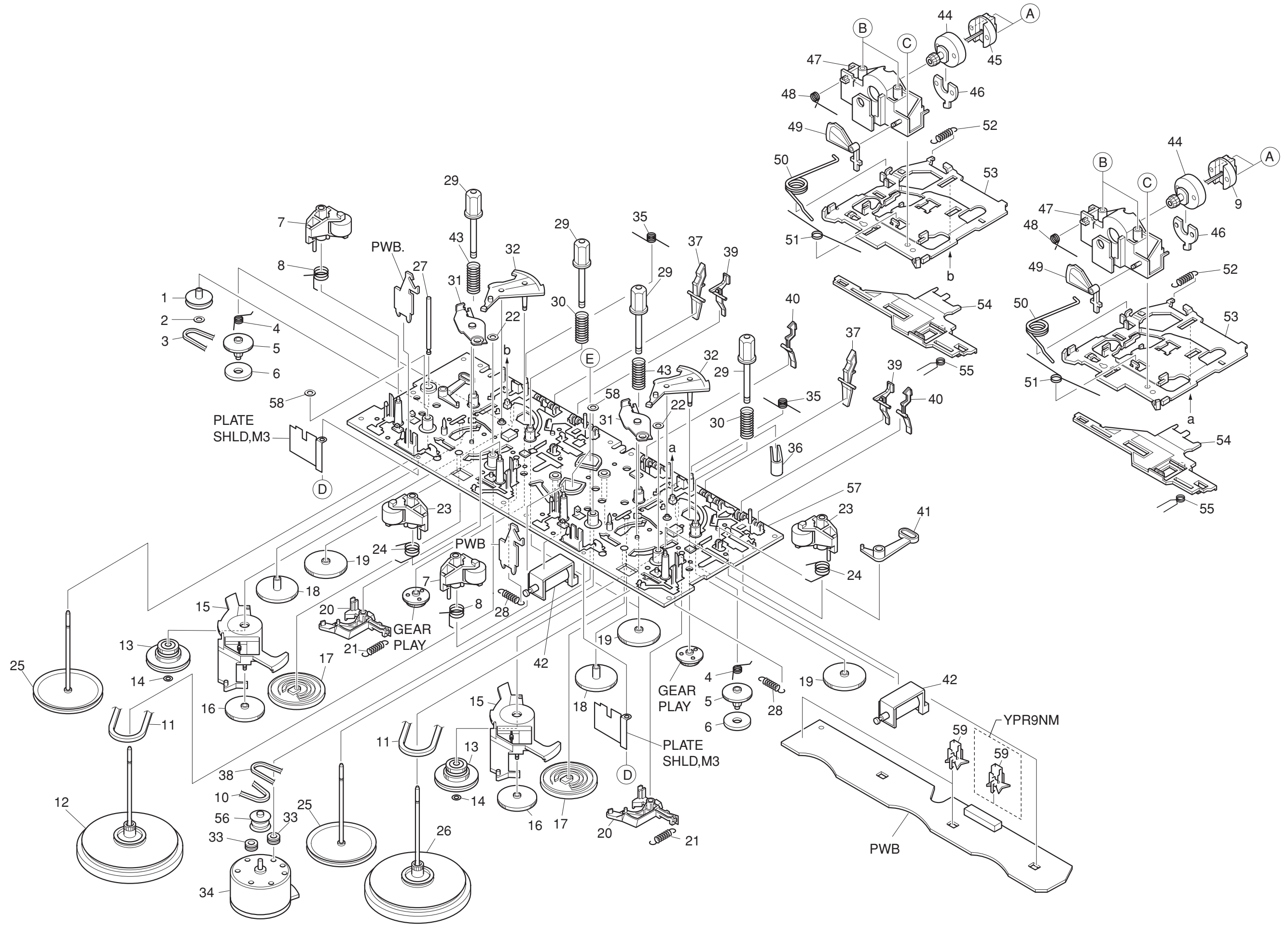

TAPE MECHANISM PARTS LIST 1 / 1 <LH>

REF. NO.	PART NO.	KANRI NO.	DESCRIPTION	REF. NO.	PART NO.	KANRI NO.	DESCRIPTION
1	82-ZM3-335-310		PULLEY, COUPLER M3	36	82-ZM3-340-010		SH, BELT D2
2	87-B10-043-010		W-P, 0.99-4-0.25 SLT	37	82-ZM1-242-010		LVR, CAS
3	86-ZM1-206-010		BELT, MAIN L	38	82-ZM3-329-410		BELT, SBU R2
4	82-ZM1-322-010		SPR-T, FR 60	39	82-ZM1-243-010		LVR, STOP
5	82-ZM1-220-210		GEAR, IDLER	40	82-ZM1-240-110		LVR, REC(*)
6	82-ZM3-616-010		RING MAGNET 4	41	82-ZM1-264-010		LVR, EJECT R
7	82-ZM1-341-210		LVR ASSY, PINCH L2	42	82-ZM3-627-010		SOL ASSY 27 SO
8	82-ZM1-258-210		SPR-T, PINCH L	43	82-ZM1-244-510		SPR-C, BT
9	87-A90-821-110		HEAD, RPH HADKH56 FPC	44	82-ZM1-208-310		HLDR, HEAD
10	82-ZM3-342-010		BELT, SBU MOT 3	45	87-A90-820-110		HEAD, PH HADKH25 FPC
11	82-ZM1-338-110		BELT, FR 4	46	82-ZM1-314-110		PLATE, HEAD
12	09-001-420-010		FLY-WHL, R ASSY	47	82-ZM1-207-910		GUIDE, TAPE
13	82-ZM3-333-310		SLIP DISK ASSY 2	48	82-ZM3-353-010		SPR-T, HEAD 2
14	82-ZM3-334-010		PW 2.16-6-0.4	49	82-ZM1-210-110		GEAR, H T
15	82-ZM3-306-110		LVR, FR M2	50	82-ZM1-219-110		SPR-T, LINK
16	82-ZM1-225-210		GEAR, FR	51	82-ZM1-269-210		SPR-T, BRG
17	82-ZM3-305-310		GEAR, CAM M2(*)	52	82-ZM1-218-010		SPR-E, HB
18	82-ZM1-226-010		GEAR, REW	53	82-ZM1-206-910		CHAS, HEAD
19	82-ZM1-216-510		GEAR, REEL	54	82-ZM1-266-310		LVR, DIR
20	82-ZM1-227-310		LVR, TRIG	55	82-ZM1-214-010		SPR-T, DIR
21	82-ZM1-265-310		SPR-E, TRIG	56	82-ZM3-221-210		PULLEY, MOT 2M
22	80-ZM6-243-010		SH 1.75-3.6-0.5 SLT	57	82-ZM3-301-610		CHAS ASSY, M2
23	82-ZM1-344-210		LVR ASSY, PINCH R2	58	82-ZM1-288-010		SH, 1.63-3.2-0.5 SLT
24	82-ZM1-259-210		SPR-T, PINCH R	59	82-ZM3-351-010		HLDR, IC 2
25	82-ZM1-234-310		FLY-WHL, L ASSY	A	80-ZM6-207-010		V+1.6-7
26	82-ZM1-237-610		FLY-WHL, R ASSY	B	86-ZM4-206-110		S-SCREW, AZIMUTH L
27	82-ZM3-339-110		SHAFT, COUPLER N3	C	85-ZM3-202-010		S-SCREW, TG
28	82-ZM1-255-310		SPR-E, LVR DIR	D	82-ZM3-222-010		S-SCREW, SHILD PLATE
29	82-ZM1-217-410		REEL TABLE	E	82-ZM3-318-110		S-SCREW W, MOTOR M2
30	82-ZM1-285-410		SPR-C, BT L				
31	82-ZM1-333-210		PLATE, LINK2				
32	82-ZM1-222-310		LVR, PLAY(*)				
33	82-ZM3-307-010		CUSH-G, DIA3.7-8-3.2				
34	87-045-347-010		MOT, SHU2L 70				
35	82-ZM1-257-010		SPR-T, CAS				

GENERAL SPEAKER DISASSEMBLY INSTRUCTIONS (FOR REFERENCE)

Type.1

Insert a flat-bladed screwdriver into the position indicated by the arrows and remove the panel. Remove the screws of each speaker unit and then remove the speaker units.

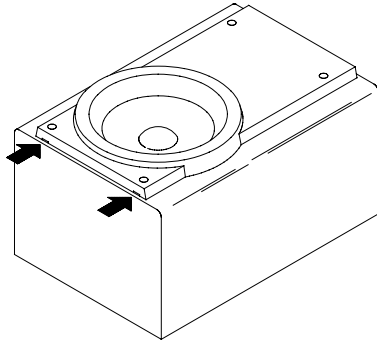

Type.2

Remove the grill frame and four pieces of rubber caps by pulling out with a flat-bladed screwdriver. Remove the screws from hole where installed rubber caps. Insert a flat-bladed screwdriver into the position indicated by the arrows and remove the panel. Remove the screws of each speaker unit and then remove the speaker units.

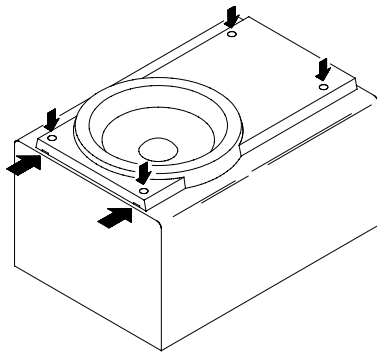

Type.3

Insert a flat-bladed screwdriver into the position indicated by the arrows and remove the panel. Turn the speaker unit to counter-clockwise direction while inserting a flat-bladed screwdriver into one of the hollows around speaker unit, and then remove the speaker unit. After replacing the speaker unit, install it turning to clockwise direction until "click" sound comes out.

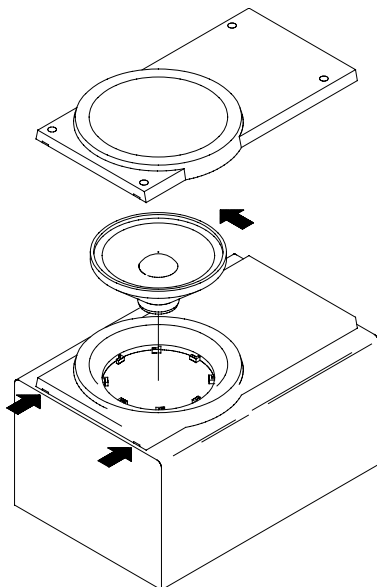

Type.4

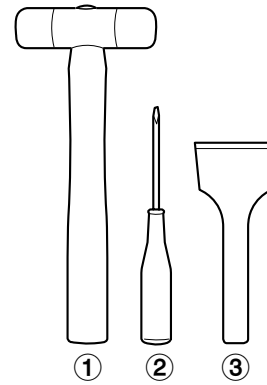

TOOLS

- ① Plastic head hammer
- ② (⊖) flat head screwdriver
- ③ Cut chisel

How to Remove the PANEL, FR

1. Insert the (⊖) flat head screwdriver tip into the gap between the PANEL, FR and the PANEL, SPKR. Tap the head of the (⊖) flat head screwdriver with the plastic hammer head, and create the clearance as shown in Fig-1.
2. Insert the cut chisel in the clearance, and tap the head of the cut chisel with plastic hammer as shown in Fig-2, to remove the PANEL, FR.
3. Place the speaker horizontally. Tap head of the cut chisel with plastic hammer as shown in Fig-3, and remove the PANEL, FR completely.

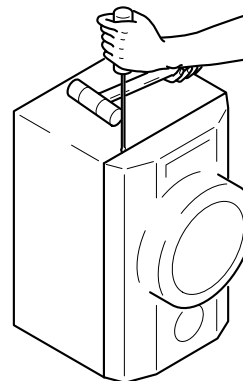

Fig-1

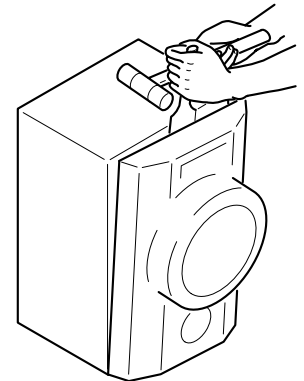

Fig-2

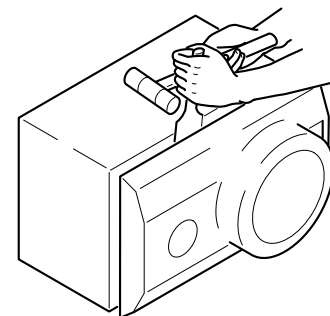

Fig-3

How to Attach the PANEL, FR

Attach the PANEL, FR to the PANEL, SPKR. Tap the four corners of the PANEL, FR with the plastic hammer to fit the PANEL, FR into the PANEL, SPKR completely.

SPEAKER PARTS LIST <SX-NAJ702 (YUSC), SX-NSZ705 (YLSC)>

REF. NO.	PART NO.	KANRI NO.	DESCRIPTION
1	8B-NSJ-001-010		PANEL,FR
2	8B-NSJ-003-010		PANEL,DUCT
3	8B-NSJ-004-010		PROTECTOR
4	8B-NSJ-602-010		SPKR, W 160
5	8B-NSJ-604-010		SPKR, TW 60
6	8B-NSJ-612-010		CORD, SPKR

SPEAKER PARTS LIST <SX-WNSZ703 (YLSL)>

REF. NO.	PART NO.	KANRI NO.	DESCRIPTION
1	8B-NS8-001-010		PANEL,FR
2	8B-NS8-002-010		PANEL,SP A
3	8B-NS8-003-010		PANEL,SP B
4	8B-NS8-004-010		PANEL,DUCT
5	8B-NS8-007-010		PROTECTOR,M
6	8B-NS8-602-010		SPKR, W 160R 35/4
7	8B-NS8-604-010		SPKR, M 100W
8	88-NSK-610-010		SPKR,CERAMIC ASSY
9	88-NS5-610-010		CORD, SPKR

ACCESSORIES / PACKAGE LIST

REF. NO.	PART NO.	KANRI NO.	DESCRIPTION
1	8B-NFJ-902-010		IB,LH(ESP)M<LH>
1	8B-NFJ-903-010		IB,U(ESF)M<U>
2	8B-NF7-702-010		RC UNIT,RC-BAS02
△ 3	87-A91-017-010		PLUG,CONVERSION JT-0476<LH>
4	87-043-115-010		FEEDER-ANT,FM
5	87-A92-150-010		ANT,LOOP AM NO-CONT

アイワ株式会社 〒110-8710 東京都台東区池之端1-2-11 ☎03(3827)3111 (代表)
AIWA CO.,LTD. 2-11, IKENOHATA 1-CHOME, TAITO-KU, TOKYO 110, JAPAN TEL:03 (3827) 3111