

SERVICE MANUAL

COMPACT DISC STEREO
CASSETTE RECEIVER

BASIC TAPE MECHANISM: 2ZM-3MK2 YPR4NM
BASIC CD MECHANISM: AZG-1 YZD3RDM

SYSTEM	CD-CASSEIVER	SPEAKER	REMOTE CONTROLLER
NSX-SZ71	CX-NSZ71	SX-WNSZ70	RC-ZAS01

- This Service Manual is the "Supplement" and replaces "Simple Manual" NSX-SZ71 (S/M Code No. 09-002-425-3T3).
- This Service Manual contains informations about the difference between NSX-SZ71 (LH) and NSX-SZ70/SZ73 (LH). If requiring the other information, see Service Manual of NSX-SZ70/SZ73 (LH). (S/M Code No. 09-004-425-3R1).
- If requiring information about the CD mechanism, see Service Manual of AZG-1 (S/M Code No. 09-001-335-3N8).

aiwa
S/M Code No. 09-006-425-3S1

SUPPLEMENT
DATA

SPECIFICATIONS

<FM Tuner section>

Tuning range	87.5 MHz to 108 MHz
Usable sensitivity(IHF)	13.2 dBf
Antenna terminals	75 ohms (unbalanced)

<AM Tuner section>

Tuning range	530 kHz to 1710 kHz (10 kHz step) 531 kHz to 1602 kHz (9 kHz step)
Usable sensitivity	350 uV/m
Antenna	Loop antenna

<Amplifier section>

Mid-high frequency amplifier

Power output	Rated: 32 W + 32 W (8 ohms, T.H.D. 1 %,1 kHz) Reference: 40 W + 40 W (8 ohms, T.H.D. 10 %,1 kHz)
Total harmonic distortion	0.1 % (15 W, 1 kHz, 8 ohms, DIN AUDIO)

Low frequency amplifier

Power output	Rated: 96 W + 96 W (6 ohms, T.H.D. 1 %, 135 Hz) Reference: 120 W + 120 W (6 ohms, T.H.D. 10 %,135 Hz)
Total harmonic distortion	0.1 % (50 W,135 Hz,6 ohms, DIN AUDIO)

Inputs

VIDEO/AUX : 300 mV (adjustable)
MD: 316 mV (adjustable)
MIC: 1.8 mV (10 kohms)

Outputs

SPEAKERS HIGH FREQ :
accept speakers of 8 ohms or more
SPEAKERS LOW FREQ :
accept speakers of 6 ohms or more
SURROUND SPEAKERS :
accept speakers of 8 to 16 ohms
LINE OUT: 210 mV
PHONES (stereo jack) : accepts
headphones of 32 ohms or more

<Cassette deck section>

Track format

Frequency response

4 tracks, 2 channels stereo
CrO2 tape: 50 Hz – 16000 Hz
Normal tape: 50 Hz – 15000 Hz

Recording system

Heads

AC bias
Deck 1: Playback head x 1
Deck 2: Recording/Playback head
x 1, erase head x 1

<Compact disc player section>

Laser	Semiconductor laser ($\lambda = 780 \text{ nm}$)
D-A converter	1 bit dual
Signal-to-noise ratio	85 dB (1 kHz, 0 dB)
Harmonic distortion	0.05 % (1 kHz, 0 dB)
Wow and flutter	Unmeasurable

<Speaker system SX-WNSZ70>

Speaker system	3 way, Built-in subwoofer(magnetic shielded type
Speaker units	Subwoofer : 160 mm cone type Full range: 100 mm cone type Super Tweeter : 20 mm ceramic type
Impedance	6 ohms / 8 ohms
Sensitivity	87 dB/W/m
Dimensions (W x H x D)	240 x 324 x 281 mm
Weight	5.0 kg

<General>

Power requirements 120 V/220-230 V/240 V
switchable, 50/60Hz

Power consumption

Power consumption in standby mode

200W
If the power-economizing mode is
ECO OFF: 21 W
If the power-economizing mode is
ECO ON or ECO AUTO: 0.9 W

Dimensions (W x H x D)

Weight

260 x 330 x 395mm
9.5 kg

- Design and specifications are subject to change without notice.

- The word "BBE"and the "BBE symbol" are trademarks of BBE Sound, Inc.
Under license from BBE Sound,Inc.

ACCESSORIES / PACKAGE LIST

REF. NO.	PART NO.	KANRI NO.	DESCRIPTION
1	8A-NF7-932-010		IB, LH-KIT (BRA)
2	87-006-225-010		AM LOOP ANT NC2
3	87-043-115-010		ANT, FEEDER FM
△ 4	87-A91-017-010		PLUG, CONVERSION JT-0476
5	8Z-NF8-702-010		RC UNIT, RC-ZAS01

ELETRICAL MAIN PARTS LIST

REF. NO.	PART NO.	KANRI NO.	DESCRIPTION	REF. NO.	PART NO.	KANRI NO.	DESCRIPTION
IC				C28	87-010-406-080		CAP, ELECT 22-25V
	8A-NF6-610-030		C-IC,LC876564V-5P35	C31	87-010-263-080		CAP, ELECT 100-10V
	87-A21-418-010		IC,STK490-340	C32	87-010-197-080		CAP, CHIP 0.01 DM
	87-A21-397-010		IC,STK490-070	C34	87-010-384-080		CAP, ELECT 100-25V
	87-A21-482-010		IC,RPM6938-H4	C35	87-010-406-080		CAP, ELECT 22-50V
	87-A20-783-040		C-IC,BA7762AFS	C36	87-010-381-080		CAP, ELECT 330-16V
	87-A21-577-040		C-IC,M61506FP	C38	87-010-394-080		CAP, ELECT 220-35V
	87-A21-021-040		C-IC,BU2099FV	C39	87-010-394-080		CAP, ELECT 220-35V
	87-070-289-040		IC,BU 2092F	C40	87-010-197-080		CAP, CHIP 0.01 DM
	87-A21-452-040		C-IC,BD3876KS2	C60	87-010-403-080		CAP, ELECT 3.3-50V
	87-A21-051-040		C-IC,BU9990-03FS	C80	87-010-401-080		CAP, ELECT 1-50V
	87-A21-560-010		IC,LA1844L-A	C81	87-010-260-080		CAP, 47-25 M 11L SME
	87-070-127-110		IC,LC72131 D	C82	87-010-380-080		CAP, ELECT 47-16V
	87-020-454-010		IC,DN6851	C104	87-010-196-080		CHIP CAPACITOR,0.1-25
				C105	87-010-196-080		CHIP CAPACITOR,0.1-25
TRANSISTOR				C111	87-010-545-080		CAP, ELECT 0.22-50V
	87-026-245-080		TR,DTC114ES	C112	87-010-545-080		CAP, ELECT 0.22-50V
	87-026-609-080		TR,KTA1266GR	C113	87-010-545-080		CAP, ELECT 0.22-50V
	87-A30-198-080		TR,KTC3199GR	C114	87-010-545-080		CAP, ELECT 0.22-50V
	87-026-610-080		TR,KTC3198GR	C115	87-010-546-080		CAP, ELECT 0.33-50V
	87-A30-076-080		C-TR,2SC3052F	C116	87-010-546-080		CAP, ELECT 0.33-50V
	87-A30-075-080		C-TR,2SA1235F	C121	87-010-545-080		CAP, ELECT 0.22-50V
	87-A30-318-080		TR,CSA952K	C122	87-010-545-080		CAP, ELECT 0.22-50V
	89-213-702-010		TR,2SB1370 (1.8W)	C171	87-012-368-080		C-CAP,S 0.1-50 F
	87-A30-087-080		C-FET,2SK2158	C172	87-012-368-080		C-CAP,S 0.1-50 F
	87-A30-107-070		C-TR,CMBT5401	C173	87-012-368-080		C-CAP,S 0.1-50 F
	87-A30-073-080		C-TR,RT1N 141C	C174	87-012-368-080		C-CAP,S 0.1-50 F
	87-A30-074-080		C-TR,RT1P 141C	C301	87-010-318-080		C-CAP,S 47P-50 CH
	87-A30-269-040		C-FET,2SJ461-T1	C302	87-010-318-080		C-CAP,S 47P-50 CH
	87-A30-106-070		C-TR,CMBT5551	C303	87-012-157-080		C-CAP,S 330P-50 CH
	87-A30-105-080		C-TR,RT1P 441C	C304	87-012-157-080		C-CAP,S 330P-50 CH
	87-A30-086-040		C-TR,CSD1306E	C305	87-012-157-080		C-CAP,S 330P-50 CH
	87-A30-329-080		TR,CD1585BC	C306	87-012-157-080		C-CAP,S 330P-50 CH
	89-327-143-080		TR,2SC2714 (0.1W)	C307	87-010-196-080		CHIP CAPACITOR,0.1-25
	87-A30-072-080		C-TR,RT1P 144C	C309	87-010-196-080		CHIP CAPACITOR,0.1-25
	87-A30-234-080		TR,CSC4115BC	C310	87-010-196-080		CHIP CAPACITOR,0.1-25
	87-026-463-080		TR,2SA933SRS	C311	87-010-198-080		CAP, CHIP 0.022
				C312	87-010-198-080		CAP, CHIP 0.022
				C313	87-010-179-080		CAP,CHIP S B1200P
				C314	87-010-179-080		CAP,CHIP S B1200P
DIODE				C315	87-010-179-080		CAP,CHIP S B1200P
	87-A40-548-090		DIODE,D3SBA20	C316	87-010-179-080		CAP,CHIP S B1200P
	87-017-654-060		DIODE,GBU6J	C321	87-012-142-080		CAP, S 0.33-16
	87-A40-547-090		DIODE,D5SBA20	C322	87-012-142-080		CAP, S 0.33-16
	87-020-465-080		DIODE,1SS133	C324	87-010-260-080		CAP, ELECT 47-25V
	87-A40-553-080		DIODE,1N4003 LES	C325	87-010-370-080		CAP,E 330-6.3 SME
	87-A40-781-080		ZENER,UZ36BSA	C327	87-010-404-080		CAP, ELECT 4.7-50V
	87-A40-764-080		ZENER,UZ10BSC	C328	87-010-404-080		CAP, ELECT 4.7-50V
	87-A40-313-080		C-DIODE,MC 2840	C332	87-010-196-080		CHIP CAPACITOR,0.1-25
	87-A40-270-080		C-DIODE,MC2838	C335	87-010-401-080		CAP, ELECT 1-50V
	87-A40-269-080		C-DIODE,MC2836	C336	87-010-401-080		CAP, ELECT 1-50V
	87-A40-768-080		ZENER,UZ16BSA	C337	87-010-196-080		CHIP CAPACITOR,0.1-25
	87-A40-752-080		ZENER,UZ6.2BSC	C339	87-010-196-080		CHIP CAPACITOR,0.1-25
	87-A40-802-080		ZENER,UZ5.1BSC	C340	87-010-196-080		CHIP CAPACITOR,0.1-25
	87-017-978-080		DIODE,1N4003	C351	87-012-140-080		CAP 470P
	87-A40-745-080		ZENER,UZ4.7BSA	C352	87-012-140-080		CAP 470P
	87-A40-748-080		ZENER,UZ5.6BSA	C354	87-010-175-080		CAP 560P
	87-017-149-080		ZENER,HZS6A2L	C355	87-010-178-080		CHIP CAP 1000P
	87-A40-736-080		DIODE,1N4148M(SEM)	C356	87-010-260-080		CAP, ELECT 47-25V
				C357	87-010-197-080		CAP, CHIP 0.01 DM
				C358	87-010-183-080		C-CAP,S 2700P-50 B
				C359	87-010-183-080		C-CAP,S 2700P-50 B
				C360	87-010-183-080		C-CAP,S 2700P-50 B
				C363	87-A10-292-080		CAP,M 5600P-50 J
				C370	87-010-196-080		CHIP CAPACITOR,0.1-25
				C373	87-016-083-080		C-CAP,S 0.15-16 RK
				C374	87-016-083-080		C-CAP,S 0.15-16 RK
				C378	87-010-196-080		CHIP CAPACITOR,0.1-25
				C379	87-010-382-080		CAP, ELECT 22-25V
				C380	87-010-382-080		CAP, ELECT 22-25V
MAIN C.B							
C3	87-012-368-080		C-CAP,S 0.1-50 F				
C4	87-012-368-080		C-CAP,S 0.1-50 F				
C21	87-016-658-000		CAP,E 4700-35 M SMG				
C22	87-016-658-000		CAP,E 4700-35 M SMG				
C25	87-010-405-080		CAP, ELECT 10-25V				
C26	87-010-406-080		CAP, ELECT 22-25V				
C27	87-010-405-080		CAP, ELECT 10-25V				

REF. NO.	PART NO.	KANRI NO.	DESCRIPTION	REF. NO.	PART NO.	KANRI NO.	DESCRIPTION
C381	87-010-197-080		CAP, CHIP 0.01 DM	C801	87-010-403-080		CAP, ELECT 3.3-50V
C382	87-010-312-080		C-CAP,S 15P-50 CH	C802	87-012-369-080		C-CAP,S 0.047-50F
C383	87-010-197-080		CAP, CHIP 0.01 DM	C803	87-010-198-080		CAP, CHIP 0.022
C384	87-010-402-080		CAP, ELECT 2.2-50V	C804	87-010-263-080		CAP, ELECT 100-10V
C386	87-010-196-080		CHIP CAPACITOR,0.1-25	C806	87-010-401-040		CAP,E 1-50 SME
C387	87-012-145-080		CAP, CHIP S 270P CH	C807	87-010-400-080		CAP, ELECT 0.47-50V
C388	87-012-156-080		C-CAP,S 220P-50 CH	C808	87-010-401-080		CAP, ELECT 1-50V
C391	87-010-319-080		C-CAP,S 56P-50 CH	C809	87-010-401-080		CAP, ELECT 1-50V
C392	87-010-319-080		C-CAP,S 56P-50 CH	C810	87-010-263-040		CAP,E 100-10
C393	87-010-319-080		C-CAP,S 56P-50 CH	C810	87-010-196-080		CHIP CAPACITOR,0.1-25
C394	87-010-319-080		C-CAP,S 56P-50 CH	C811	87-010-403-080		CAP, ELECT 3.3-50V
C536	87-010-196-080		CHIP CAPACITOR,0.1-25	C811	87-010-545-040		CAP,E 0.22-50 SME
C609	87-010-181-080		CAP,CHIP S 1800P	C812	87-010-403-080		CAP, ELECT 3.3-50V
C610	87-010-181-080		CAP,CHIP S 1800P	C812	87-010-405-040		CAP,E 10-50
C611	87-010-956-080		CHIP-CAP,S 0.068-25B	C814	87-010-197-080		CAP, CHIP 0.01 DM
C612	87-016-369-080		C-CAP,S 0.033-25 B K	C815	87-010-403-080		CAP, ELECT 3.3-50V
C613	87-010-197-080		CAP, CHIP 0.01 DM	C816	87-010-403-080		CAP, ELECT 3.3-50V
C614	87-016-669-080		C-CAP,S 0.1-25 K B	C821	87-010-405-080		CAP, ELECT 10-50V
C616	87-010-184-080		CHIP CAPACITOR 3300P(K)	C823	87-010-177-080		C-CAP,S 820P-50 SL
C617	87-012-369-080		C-CAP,S 0.047-50F	C824	87-010-404-080		CAP, ELECT 4.7-50V
C618	87-010-401-080		CAP, ELECT 1-50V	C825	87-010-596-080		CAP, S 0.047-16
C619	87-010-263-080		CAP, ELECT 100-10V	C842	87-010-197-080		CAP, CHIP 0.01 DM
C620	87-016-669-080		C-CAP,S 0.1-25 K B	C843	87-010-190-080		S CHIP F 0.01
C621	87-010-197-080		CAP, CHIP 0.01 DM	C844	87-010-197-080		CAP, CHIP 0.01 DM
C623	87-010-401-080		CAP, ELECT 1-50V	C845	87-010-190-080		S CHIP F 0.01
C624	87-010-401-080		CAP, ELECT 1-50V	C846	87-010-190-080		S CHIP F 0.01
C626	87-A11-590-080		C-CAP,S 0.047-16 K B	C847	87-010-190-080		S CHIP F 0.01
C627	87-010-400-080		CAP, ELECT 0.47-50V	C848	87-010-190-080		S CHIP F 0.01
C628	87-010-400-080		CAP, ELECT 0.47-50V	C849	87-010-190-080		S CHIP F 0.01
C629	87-A11-590-080		C-CAP,S 0.047-16 K B	C850	87-010-260-080		CAP, ELECT 47-25V
C630	87-010-383-080		CAP, ELECT 33-25V	C851	87-010-197-080		CAP, CHIP 0.01 DM
C631	87-010-185-080		C-CAP,S 3900P-50 B	C852	87-010-197-080		CAP, CHIP 0.01 DM
C632	87-010-185-080		C-CAP,S 3900P-50 B	C853	87-010-197-080		CAP, CHIP 0.01 DM
C634	87-010-196-080		CHIP CAPACITOR,0.1-25	C858	87-010-196-080		CHIP CAPACITOR,0.1-25
C635	87-A10-307-080		CAP,M 0.1-50 J	C859	87-010-196-080		CHIP CAPACITOR,0.1-25
C636	87-A10-307-080		CAP,M 0.1-50 J	C860	87-010-197-080		CAP, CHIP 0.01 DM
C637	87-A10-307-080		CAP,M 0.1-50 J	C959	87-010-196-080		CHIP CAPACITOR,0.1-25
C638	87-A10-307-080		CAP,M 0.1-50 J	C960	87-010-196-080		CHIP CAPACITOR,0.1-25
C639	87-010-405-080		CAP, ELECT 10-50V	C961	87-010-152-080		C-CAP,S 8P-50 CH
C641	87-010-401-080		CAP, ELECT 1-50V	C963	87-015-785-080		CHIP CAPACITOR, 0.1FZ-25Z
C642	87-010-401-080		CAP, ELECT 1-50V	C971	87-010-381-080		CAP, ELECT 330-16V
C643	87-010-196-080		CHIP CAPACITOR,0.1-25	C972	87-010-404-080		CAP, ELECT 4.7-50V
C644	87-010-401-080		CAP, ELECT 1-50V	C973	87-010-197-080		CAP, CHIP 0.01 DM
C671	87-010-322-080		C-CAP,S 100P-50 CH	C974	87-010-197-080		CAP, CHIP 0.01 DM
C672	87-010-322-080		C-CAP,S 100P-50 CH	C979	87-010-322-080		C-CAP,S 100P-50 CH
C673	87-010-197-080		CAP, CHIP 0.01 DM	C981	87-010-260-080		CAP, ELECT 47-25V
C679	87-010-196-080		CHIP CAPACITOR,0.1-25	C982	87-010-196-080		CHIP CAPACITOR,0.1-25
C680	87-010-197-080		CAP, CHIP 0.01 DM	C983	87-010-197-080		CAP, CHIP 0.01 DM
C682	87-010-196-080		CHIP CAPACITOR,0.1-25	C984	87-010-197-080		CAP, CHIP 0.01 DM
C771	87-010-263-080		CAP, ELECT 100-10V	C987	87-010-197-080		CAP, CHIP 0.01 DM
C772	87-010-197-080		CAP, CHIP 0.01 DM	C991	87-010-312-080		C-CAP,S 15P-50 CH
C779	87-010-426-080		C-CAP,S 0.01-25 K B	C992	87-010-312-080		C-CAP,S 15P-50 CH
C780	87-010-426-080		C-CAP,S 0.01-25 K B	C993	87-010-178-080		CHIP CAP 1000P
C782	87-010-197-080		CAP, CHIP 0.01 DM	C995	87-010-178-080		CHIP CAP 1000P
C783	87-010-197-080		CAP, CHIP 0.01 DM	C997	87-010-196-080		CHIP CAPACITOR,0.1-25
C784	87-010-197-080		CAP, CHIP 0.01 DM	C998	87-010-260-080		CAP, ELECT 47-25V
C785	87-010-197-080		CAP, CHIP 0.01 DM	C999	87-A11-155-080		CAP,TC U 0.01-16 Z F
C786	87-010-197-080		CAP, CHIP 0.01 DM	CF831	87-008-261-010		FILTER, SFE10.7MA5-A
C788	87-010-149-080		C-CAP,S 5P-50 CH	CF832	87-008-261-010		FILTER, SFE10.7MA5-A
C789	87-A10-592-080		C-CAP,S 0.015-50 J B	CN1	87-A60-996-010		CONN,13P V BLK TAC-L13X-A3
C790	87-A10-592-080		C-CAP,S 0.015-50 J B	CN91	87-A60-109-010		CONN,2P V S2M-2W
C791	87-010-196-080		CHIP CAPACITOR,0.1-25	CN101	87-A60-996-010		CONN,13P V BLK TAC-L13X-A3
C792	87-010-197-080		CAP, CHIP 0.01 DM	CN301	87-A60-620-010		CONN,3P V 2MM JMT
C793	87-010-404-080		CAP, ELECT 4.7-50V	CN351	87-A60-625-010		CONN,8P V 2MM JMT
C795	87-010-197-080		CAP, CHIP 0.01 DM	CN601	87-099-719-010		CONN,30P TYK-B(X)
C796	87-010-197-080		CAP, CHIP 0.01 DM	CN602	87-099-194-010		CONN,6P 6216V
C797	87-010-405-080		CAP, ELECT 10-50V	CNA1	8A-NF8-653-010		CONN ASSY,9P TID-A(480)
C798	87-010-197-080		CAP, CHIP 0.01 DM	CNA2	8A-NF6-630-110		CONN ASSY,3P (VM) ANF-6
C799	87-010-407-080		CAP, ELECT 33-50V	FC602	85-NF5-617-010		CABLE,FFC 6P-1.25
C800	87-012-369-080		C-CAP,S 0.047-50F	FFE831	A8-8ZA-190-030		8ZA-1 FEUNM

REF. NO.	PART NO.	KANRI NO.	DESCRIPTION	REF. NO.	PART NO.	KANRI NO.	DESCRIPTION
J101	87-A60-483-010		JACK,DIA6.3 BLK ST W/S KM	C392	87-010-320-080		CHIP CAP 68P
J102	87-A60-238-010		TERMINAL,SP 4P (MSC)	C401	87-010-196-080		CHIP CAPACITOR,0.1-25
J601	87-A60-885-010		JACK,PIN 6P R/W MSC	C402	87-010-196-080		CHIP CAPACITOR,0.1-25
J831	87-A60-202-010		TERMINAL,ANT 4P MSP-154V-02	C403	87-010-322-080		C-CAP,S 100P-50 CH
L101	87-003-383-010		COIL,1UH-S	C404	87-010-322-080		C-CAP,S 100P-50 CH
L102	87-003-383-010		COIL,1UH-S	C405	87-010-322-080		C-CAP,S 100P-50 CH
L301	87-A50-049-010		COIL,TRAP 85K(COI)	C406	87-010-322-080		C-CAP,S 100P-50 CH
L302	87-A50-049-010		COIL,TRAP 85K(COI)	C407	87-010-322-080		C-CAP,S 100P-50 CH
L351	87-007-342-010		COIL,OSC 85K BIAS	C408	87-010-322-080		C-CAP,S 100P-50 CH
L801	87-A50-608-010		COIL,FM DET-N(TOK)	C409	87-010-196-080		C-CAP,S 0.1-25 Z F C2012
L802	87-A91-551-010		FLTR,PCFJZH-450 L(TOK)	C501	87-010-544-040		CAP,E 0.1-50 SME
L811	87-005-847-080		COIL,2.2UH(CECS)	C502	87-010-196-080		CHIP CAPACITOR,0.1-25
L832	87-005-847-080		COIL,2.2UH K CECS	C503	87-010-544-040		CAP,E 0.1-50 SME
L951	8A-NF8-667-010		COIL,AM PACK 4(TOK)	C504	87-012-156-080		C-CAP,S 220P-50 CH
R161	87-A00-441-050		RES,270-1/2W J RP	C505	87-010-178-080		CHIP CAP 1000P
R162	87-A00-441-050		RES,270-1/2W J RP	C521	87-010-178-080		CHIP CAP 1000P
R163	87-A00-441-050		RES,270-1/2W J RP	C601	87-010-186-080		CAP,CHIP 4700P
R164	87-A00-441-050		RES,270-1/2W J RP	C603	87-010-320-080		CHIP CAP 68P
R790	87-010-197-080		CAP,CHIP 0.01 DM	C604	87-010-546-040		CAP,E 0.33-50
R991	87-010-322-080		C-CAP,S 100P-50 CH	C606	87-010-112-040		CAP,E 100-16
R993	87-010-322-080		C-CAP,S 100P-50 CH	C607	87-010-196-080		CHIP CAPACITOR,0.1-25
R995	87-010-322-080		C-CAP,S 100P-50 CH	C609	87-010-196-080		CHIP CAPACITOR,0.1-25
SFR351	87-A90-433-080		SFR,50K H NVZ6TLTA	C621	87-010-178-080		CHIP CAP 1000P
SFR352	87-A90-433-080		SFR,50K H NVZ6TLTA	C652	87-010-183-080		C-CAP,S 2700P-50 B
WH1	87-A90-510-010		HLDR,WIRE 2.5-9P	C653	87-010-213-080		C-CAP,S 0.015-50 B
X991	87-A70-061-010		VIB,XTAL 4.500MHZ CSA-309	C701	87-010-260-040		CAP,E 47-25 SME
				C802	87-010-168-080		CAP,CHIP 150P
				C804	87-010-187-080		CAP CHIP S5600P
				C808	87-010-196-080		CHIP CAPACITOR,0.1-25
				C809	87-012-155-080		C-CAP 180P-50CH
FRONT C.B				CN102	8A-NF7-605-010		CONN ASSY,4P V 80MM
C101	87-010-190-080		S CHIP F 0.01	CN104	87-099-017-010		CONN, 15P 6216 V
C102	87-010-322-080		C-CAP,S 100P-50 CH	CN901	87-A60-138-010		CONN,13P V FE
C103	87-010-312-080		C-CAP,S 15P-50 CH	CON101	87-099-720-010		CONN,30P TYK-B(P)
C104	87-012-157-080		C-CAP,S 330P-50 CH	FB601	87-008-372-080		FILTER, EMI BL OIRNI
C105	87-010-406-040		CAP,E 22-50 SME				
C106	87-010-493-040		CAP,E 0.47-50 GAS	FB801	87-008-372-080		FILTER, EMI BL OIRNI
C107	87-A10-189-040		CAP,E 220-10	FC104	88-915-111-110		FF-CABLE,15P 1.25
C108	87-A10-189-040		CAP,E 220-10	FC901	85-NF5-618-010		CABLE,FFC 13P-1.25
C109	87-010-196-080		CHIP CAPACITOR,0.1-25	FL201	8A-NF7-601-010		FL,BJ754GNK
C110	87-010-178-080		CHIP CAP 1000P	J601	87-A61-242-010		JACK,6.3 BLK MONO W/SW V KM
C112	87-012-368-080		C-CAP,S 0.1-50 F	L101	87-A50-333-010		COIL,OSC 9.43MHZ
C113	87-012-369-080		C-CAP,S 0.047-50F	L801	87-A50-093-010		COIL,CLOCK 5.76MHZ
C114	87-010-196-080		CHIP CAPACITOR,0.1-25	L802	87-005-847-080		COIL,2.2UH(CECS)
C115	87-010-196-080		CHIP CAPACITOR,0.1-25	LED401	87-017-733-080		LED,SEL1250SM
C116	87-010-196-080		CHIP CAPACITOR,0.1-25	LED402	87-017-733-080		LED,SEL1250SM
C118	87-012-145-080		CAP,CHIP S 270P CH	LED403	87-017-733-080		LED,SEL1250SM
C119	87-010-498-040		CAP,E 10-16 GAS	LED404	87-017-733-080		LED,SEL1250SM
C120	87-010-196-080		CHIP CAPACITOR,0.1-25	LED405	87-017-733-080		LED,SEL1250SM
C121	87-010-196-080		CHIP CAPACITOR,0.1-25	LED416	87-A40-619-080		LED,SLR-56PT-TE7-W GRN
C122	87-010-196-080		CHIP CAPACITOR,0.1-25	LED417	87-A40-619-080		LED,SLR-56PT-TE7-W GRN
C123	87-012-393-080		C-CAP,S 0.22-16 R K	LED418	87-A40-619-080		LED,SLR-56PT-TE7-W GRN
C181	87-010-322-080		C-CAP,S 100P-50 J CH GRM	LED419	87-A40-619-080		LED,SLR-56PT-TE7-W GRN
C182	87-010-178-080		CHIP CAP 1000P	LED420	87-A40-619-080		LED,SLR-56PT-TE7-W GRN
C183	87-012-156-080		C-CAP,S 220P-50 CH	LED421	87-A40-619-080		LED,SLR-56PT-TE7-W GRN
C202	87-012-157-080		C-CAP,S 330P-50 CH	LED422	87-A40-317-080		LED,SLR-342VCT31 RED
C203	87-012-157-080		C-CAP,S 330P-50 CH	LED423	87-A40-317-080		LED,SLR-342VCT31 RED
C204	87-012-157-080		C-CAP,S 330P-50 CH	LED424	87-A40-317-080		LED,SLR-342VCT31 RED
C205	87-012-157-080		C-CAP,S 330P-50 CH	LED440	87-A40-563-010		LED,SEL6515C-LF62 PGRN
C206	87-012-156-080		C-CAP,S 220P-50 J CH GRM	LED441	87-A40-563-010		LED,SEL6515C-LF62 PGRN
C211	87-012-140-080		CAP 470P	LED442	87-A40-563-010		LED,SEL6515C-LF62 PGRN
C221	87-010-421-040		CAP,E 4.7-50 5L	LED443	87-A40-563-010		LED,SEL6515C-LF62 PGRN
C222	87-010-404-040		CAP,E 4.7-50 SME	LED444	87-A40-563-010		LED,SEL6215S-LF62 PGRN
C223	87-010-408-040		CAP,E 47-50 SME	LED445	87-A40-563-010		LED,SEL6215S-LF62 PGRN
C224	87-012-369-080		C-CAP,S 0.047-50F	LED454	87-A40-678-010		LED,SELU1E10CXM BLUE-DEF
C382	87-010-320-080		CHIP CAP 68P	LED455	87-A40-678-010		LED,SELU1E10CXM BLUE-DEF
C383	87-010-196-080		CHIP CAPACITOR,0.1-25	LED499	87-017-733-080		LED,SEL1250SM
C384	87-010-196-080		CHIP CAPACITOR,0.1-25	R211	87-012-156-080		C-CAP,S 220P-50 J CH GRM
C385	87-010-196-080		CHIP CAPACITOR,0.1-25	R212	87-012-156-080		C-CAP,S 220P-50 J CH GRM
C386	87-010-196-080		CHIP CAPACITOR,0.1-25	S101	87-A91-709-010		SW,RTRY 1-2-24 RE012103 PV
C387	87-010-196-080		CHIP CAPACITOR,0.1-25	S102	87-A91-710-010		SW,RTRY 1-2-12 RE012103 PV

REF. NO.	PART NO.	KANRI NO.	DESCRIPTION	REF. NO.	PART NO.	KANRI NO.	DESCRIPTION
S301	87-A91-024-180	SW, TACT	KSH0611BT	C217	87-010-403-080		CAP, ELECT 3.3-50V
S302	87-A91-024-180	SW, TACT	KSH0611BT	C218	87-010-403-080		CAP, ELECT 3.3-50V
S303	87-A91-024-180	SW, TACT	KSH0611BT	C221	87-010-405-080		CAP, ELECT 10-50V
S304	87-A91-024-180	SW, TACT	KSH0611BT	C222	87-010-405-080		CAP, ELECT 10-50V
S305	87-A91-024-180	SW, TACT	KSH0611BT	C223	87-010-197-080		CAP, CHIP 0.01 DM
S306	87-A91-024-180	SW, TACT	KSH0611BT	C224	87-010-197-080		CAP, CHIP 0.01 DM
S314	87-A91-024-180	SW, TACT	KSH0611BT	C251	87-010-196-080		CHIP CAPACITOR, 0.1-25
S321	87-A91-024-180	SW, TACT	KSH0611BT	C252	87-010-196-080		CHIP CAPACITOR, 0.1-25
S322	87-A91-024-180	SW, TACT	KSH0611BT	C253	87-010-196-080		CHIP CAPACITOR, 0.1-25
S323	87-A91-024-180	SW, TACT	KSH0611BT	C254	87-010-196-080		CHIP CAPACITOR, 0.1-25
S324	87-A91-024-180	SW, TACT	KSH0611BT	C255	87-010-190-080		S CHIP F 0.01
S325	87-A91-024-180	SW, TACT	KSH0611BT	C256	87-010-190-080		S CHIP F 0.01
S326	87-A91-024-180	SW, TACT	KSH0611BT	C257	87-010-190-080		S CHIP F 0.01
S327	87-A91-024-180	SW, TACT	KSH0611BT	C258	87-010-190-080		S CHIP F 0.01
S328	87-A91-024-180	SW, TACT	KSH0611BT	C401	87-010-260-080		CAP, ELECT 47-25
S329	87-A91-024-180	SW, TACT	KSH0611BT	CN101	87-A61-011-010		CONN, 13P H BLK TAC-L13P-A3
S330	87-A91-024-180	SW, TACT	KSH0611BT	CN102	87-A61-011-010		CONN, 13P H BLK TAC-L13P-A3
S331	87-A91-024-180	SW, TACT	KSH0611BT	CNA101	8A-NF8-656-010		CONN ASSY, 5P TID-A 400
S332	87-A91-024-180	SW, TACT	KSH0611BT	J201	87-A61-148-010		JACK, PIN 4P R/W BLUE
S333	87-A91-024-180	SW, TACT	KSH0611BT	L251	87-003-383-010		COIL, 1UH-K
S334	87-A91-024-180	SW, TACT	KSH0611BT	L252	87-003-383-010		COIL, 1UH-K
S341	87-A91-024-180	SW, TACT	KSH0611BT	R129	87-A00-262-080		RES, M/F 0.15-2W J
S342	87-A91-024-180	SW, TACT	KSH0611BT	R130	87-A00-262-080		RES, M/F 0.15-2W J
S343	87-A91-024-180	SW, TACT	KSH0611BT	R231	87-A00-258-080		RES, M/F 0.22-1W J
S344	87-A91-024-180	SW, TACT	KSH0611BT	R232	87-A00-258-080		RES, M/F 0.22-1W J
S345	87-A91-024-180	SW, TACT	KSH0611BT	WH101	87-A90-459-010		HLDR, WIRE 2.5-5P
S346	87-A91-024-180	SW, TACT	KSH0611BT				
S347	87-A91-024-180	SW, TACT	KSH0611BT				
S349	87-A91-024-180	SW, TACT	KSH0611BT				
S350	87-A91-024-180	SW, TACT	KSH0611BT	PT C.B			
S351	87-A91-024-180	SW, TACT	KSH0611BT	C1	87-010-387-080		CAP, E 470-25 SME
S352	87-A91-024-180	SW, TACT	KSH0611BT	C4	87-A11-148-080		CAP, TC U 0.1-50 Z F
S353	87-A91-024-180	SW, TACT	KSH0611BT	C5	87-A11-148-080		CAP, TC U 0.1-50 Z F
S354	87-A91-024-180	SW, TACT	KSH0611BT	C6	87-A10-627-000		CAP, E 2200-50 M SMG
S355	87-A91-024-180	SW, TACT	KSH0611BT	C7	87-A10-627-000		CAP, E 2200-50 M SMG
VR501	86-NFA-607-010	VR, RTRY	10K15AX1 1 V XV0121PVN	C8	87-A11-148-080		CAP, TC U 0.1-50 Z F
				C9	87-A11-148-080		CAP, TC U 0.1-50 Z F
				C10	87-A11-148-080		CAP, TC U 0.1-50 Z F
				C11	87-A11-148-080		CAP, TC U 0.1-50 Z F
				C12	87-016-657-090		CAP, E 3300-71
AMP C.B				C13	87-016-657-090		CAP, E 3300-71
C101	87-010-183-080	C-CAP, S	2700P-50 B	C16	87-010-403-080		CAP, ELECT 3.3-50V
C102	87-010-183-080	C-CAP, S	2700P-50 B	CN1	87-A61-110-010		CONN, 9P V TID-A
C103	87-010-545-080	CAP, ELECT	0.22-50V	CN2	87-A61-108-010		CONN, 5P V TID-A
C104	87-010-545-080	CAP, ELECT	0.22-50V	PT1	8A-NF7-622-010		PT, ANF-7 H
C107	87-010-405-080	CAP, ELECT	10-50V	△ PT1			
C108	87-010-405-080	CAP, ELECT	10-50V	△ PT2	8A-NF8-673-010		PT, SUB ANF-8 (H) KAMI
C111	87-010-179-080	C-CAP, S	1200P-50 K B GRM	△ RY1	87-A91-281-010		RELAY, AC DC12V OSA-SS-212DM5
C112	87-010-179-080	C-CAP, S	1200P-50 K B GRM	△ S1	87-A90-165-010		SW, SL 1-2-3 SWS2301
C113	87-010-405-080	CAP, ELECT	10-50V	△ T1	87-A60-317-010		TERMINAL, 1P MSC
C114	87-010-405-080	CAP, ELECT	10-50V	△ T2	87-A60-317-010		TERMINAL, 1P MSC
C115	87-010-866-080	CAP, ELECT	10-63				
C116	87-010-866-080	CAP, ELECT	10-63	VM C.B			
C119	87-010-197-080	CAP, CHIP	0.01 DM				
C120	87-010-197-080	CAP, CHIP	0.01 DM				
C133	87-010-190-080	C-CAP, S	0.01-50 Z F C2012	CNA3	87-049-919-010		CONN, 3P V WHT EH
C153	87-010-188-080	C-CAP, S	6800P-50 K B C2012	DECK C.B			
C201	87-A10-300-080	CAP, M	0.027-50 J	CON105	87-099-756-010		CONN, 15P 9604 S F
C202	87-A10-300-080	CAP, M	0.027-50 J	SFR1	87-024-581-010		SFR, 3.3K DIA 6H
C203	87-A10-300-080	CAP, M	0.027-50 J	SOL1	82-ZM1-618-410		SOL ASSY, 27
C204	87-A10-300-080	CAP, M	0.027-50 J	SOL2	82-ZM1-618-410		SOL ASSY, 27
C205	87-010-180-080	C-CER	1500P	SW1	87-A90-248-010		SW, MICRO ESE11SH2CXQ
C206	87-010-180-080	C-CER	1500P	SW2	87-A90-248-010		SW, MICRO ESE11SH2CXQ
C207	87-010-401-080	CAP, ELECT	1-50V	SW3	87-A90-248-010		SW, MICRO ESE11SH2CXQ
C208	87-010-401-080	CAP, ELECT	1-50V	SW4	87-036-110-010		SW, MICRO SPPB62
C209	87-010-187-080	CAP CHIP	S5600P	SW5	87-036-110-010		SW, MICRO SPPB62
C210	87-010-187-080	CAP CHIP	S5600P	SW6	87-036-110-010		SW, MICRO SPPB62
C211	87-010-402-080	CAP, ELECT	2.2-50V	SW8	87-A90-248-010		SW, MICRO ESE11SH2CXQ
C212	87-010-402-080	CAP, ELECT	2.2-50V	SW9	87-A90-248-010		SW, MICRO ESE11SH2CXQ
C215	87-010-179-080	C-CAP, S	1200P-50 K B GRM	W1	82-ZM3-601-010		RBN, CORD, 4P-75
C216	87-010-179-080	C-CAP, S	1200P-50 K B GRM				

REF. NO.	PART NO.	KANRI NO.	DESCRIPTION
HEAD-1	C.B		
	85-ZM3-602-010	PWB, FLEX A	

HEAD-2	C.B		
	85-ZM3-602-010	PWB, FLEX A	
CON351	87-NF6-616-010	CONN ASSY, 8P-RPB	

○チップ抵抗部品コード/CHIP RESISTOR PART CODE

チップ抵抗部品コードの成り立ち

Chip Resistor Part Coding

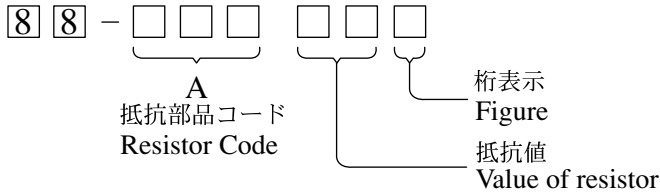

チップ抵抗
Chip resistor

容量 Wattage	種類 Type	許容誤差 Tolerance	記号 Symbol	寸法/Dimensions (mm)			抵抗コード : A Resistor Code : A	
				外形/Form	L	W		t
1/16W	1005	± 5%	CJ		1.0	0.5	0.35	104
1/16W	1608	± 5%	CJ		1.6	0.8	0.45	108
1/10W	2125	± 5%	CJ		2	1.25	0.45	118
1/8W	3216	± 5%	CJ		3.2	1.6	0.55	128

TRANSISTOR ILLUSTRATION

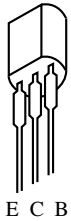

KTA1266GR CD1585BC
 KTC3198GR CSC4115BC
 KTC3199GR
 CSA952K

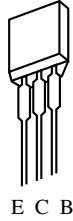

DTC114ES
 2SA933

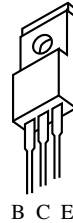

2SB1370

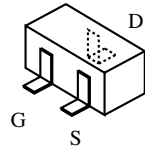

2SK2158
 2SJ461-T1

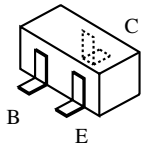

2SA1235F RT1N141C
 2SC2714 RT1P141C
 2SC3052F RT1P144C
 CMBT5551 RT1P441C
 CMBT5401
 CSD1306E

A MAIN C.B

FROM HEAD-2 C.B
CON351
1 3 5 7 8

FROM HEAD-1 C.B
CON301
1 2 3

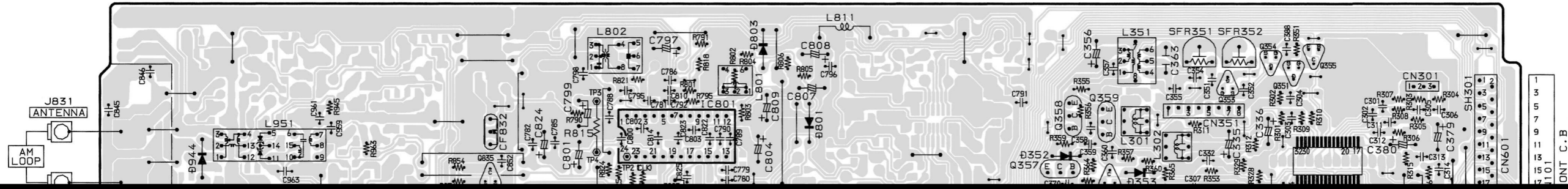

A
B
C
D
E
F
G
H
I
J
K
L
M
N
O
P
Q
R
S
T
U

SCHEMATIC DIAGRAM - 1 (MAIN 1 / 3: AMP / VM)

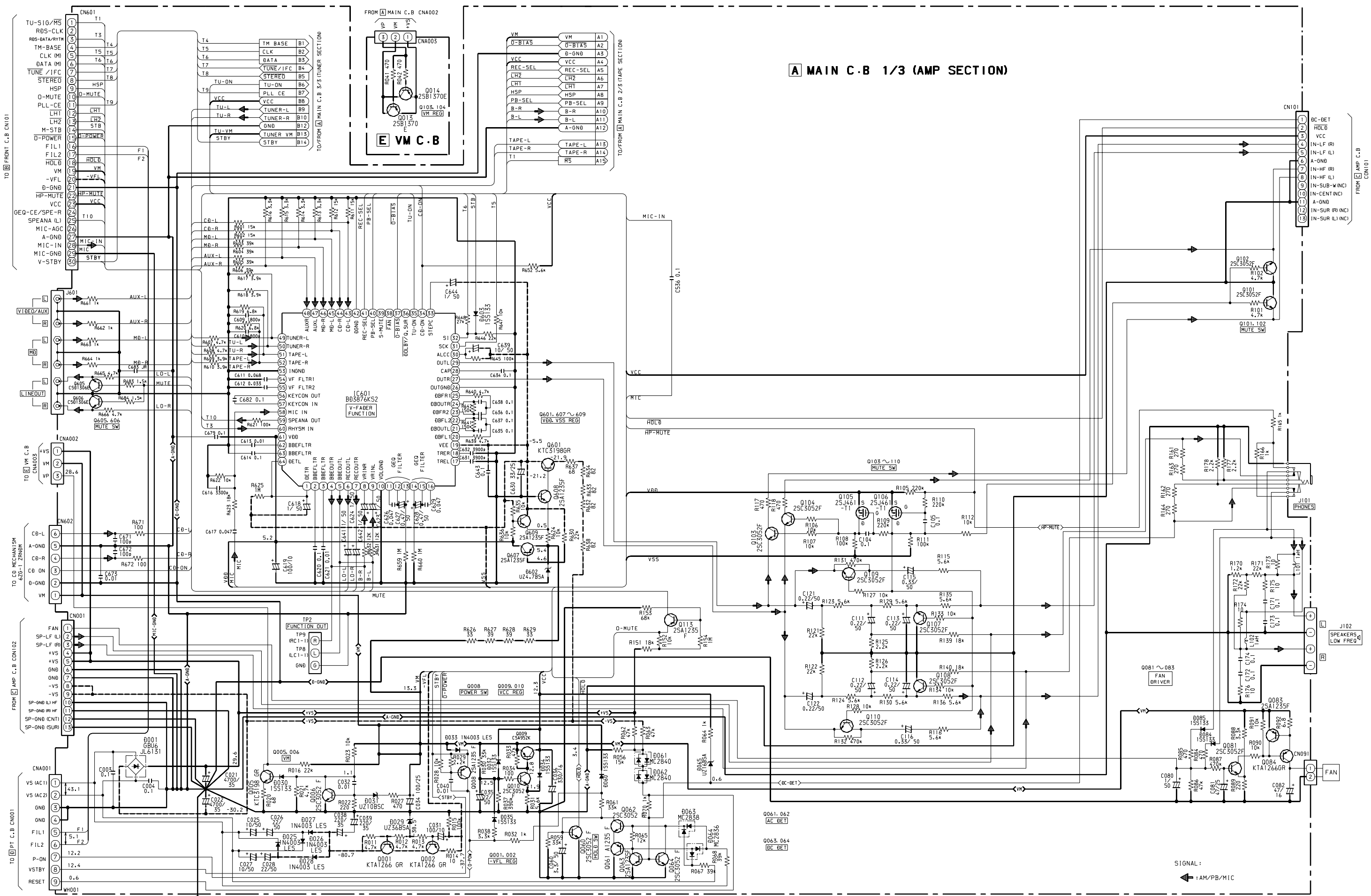

SCHEMATIC DIAGRAM - 3 (MAIN 3/3: TUNER)

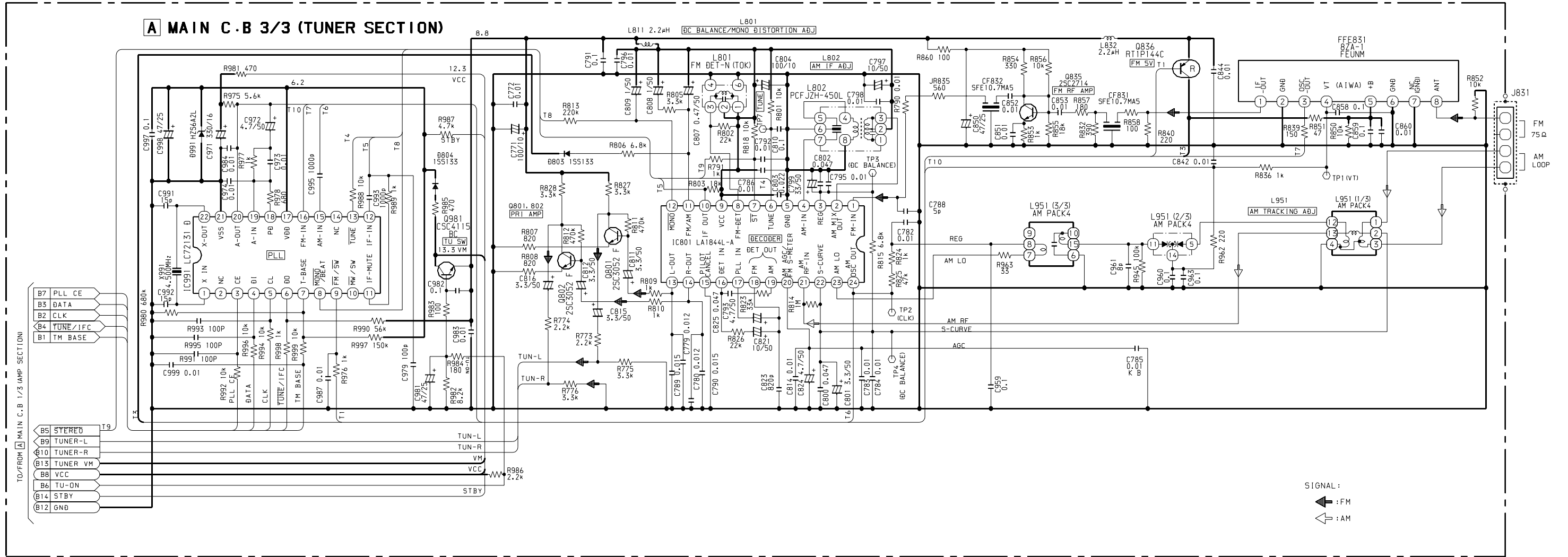

SCHEMATIC DIAGRAM - 4 (FRONT/DECK)

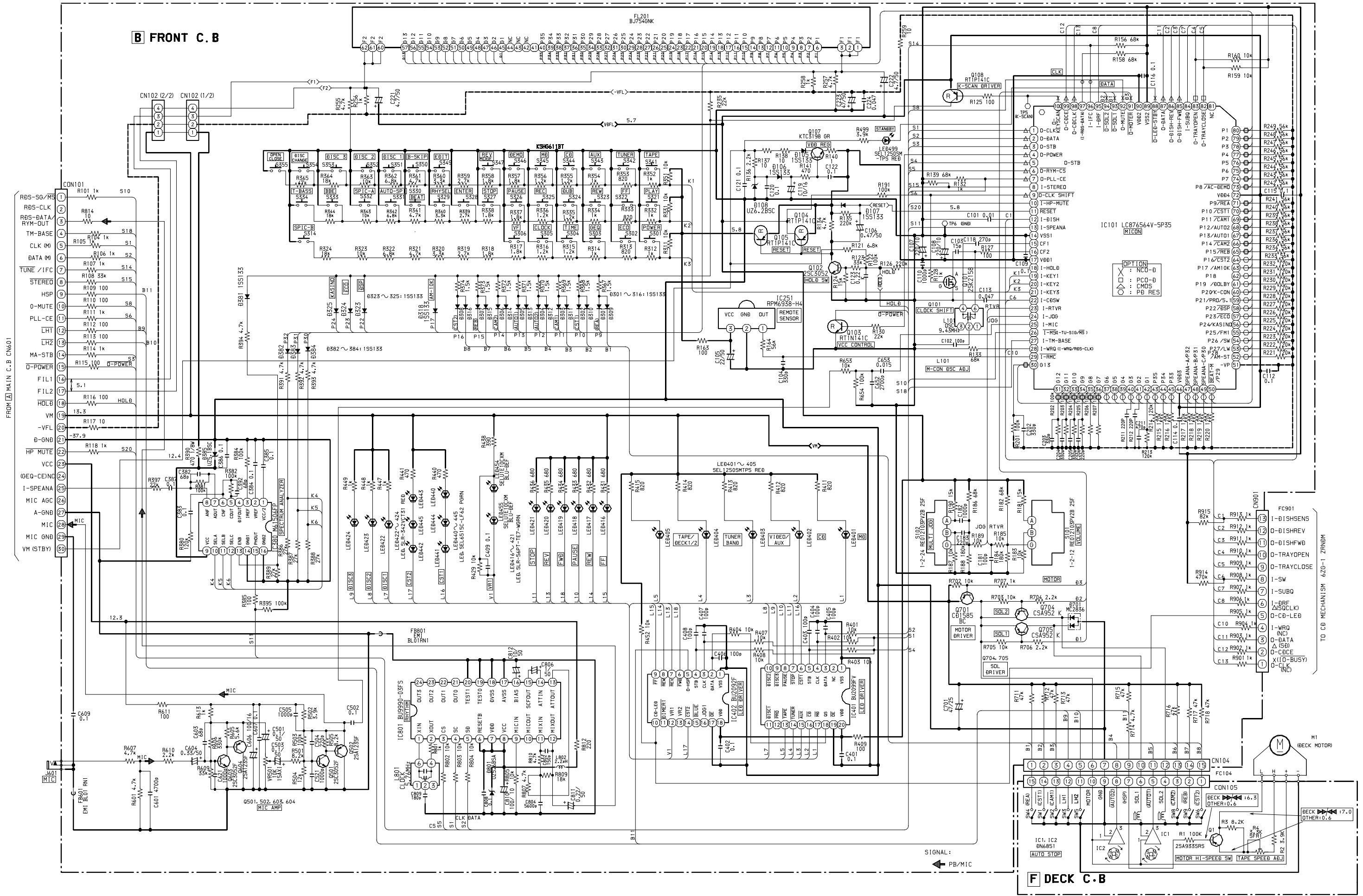

WIRING - 3 (AMP)

32	31	30	29	28	27	26	25	24	23	22	21	20	19	18	17	16	15	14	13	12	11	10	9	8	7	6	5	4	3	2	1
----	----	----	----	----	----	----	----	----	----	----	----	----	----	----	----	----	----	----	----	----	----	----	---	---	---	---	---	---	---	---	---

A
B
C
D
E
F
G
H
I
J
K
L
M
N
O
P
Q
R
S
T
U

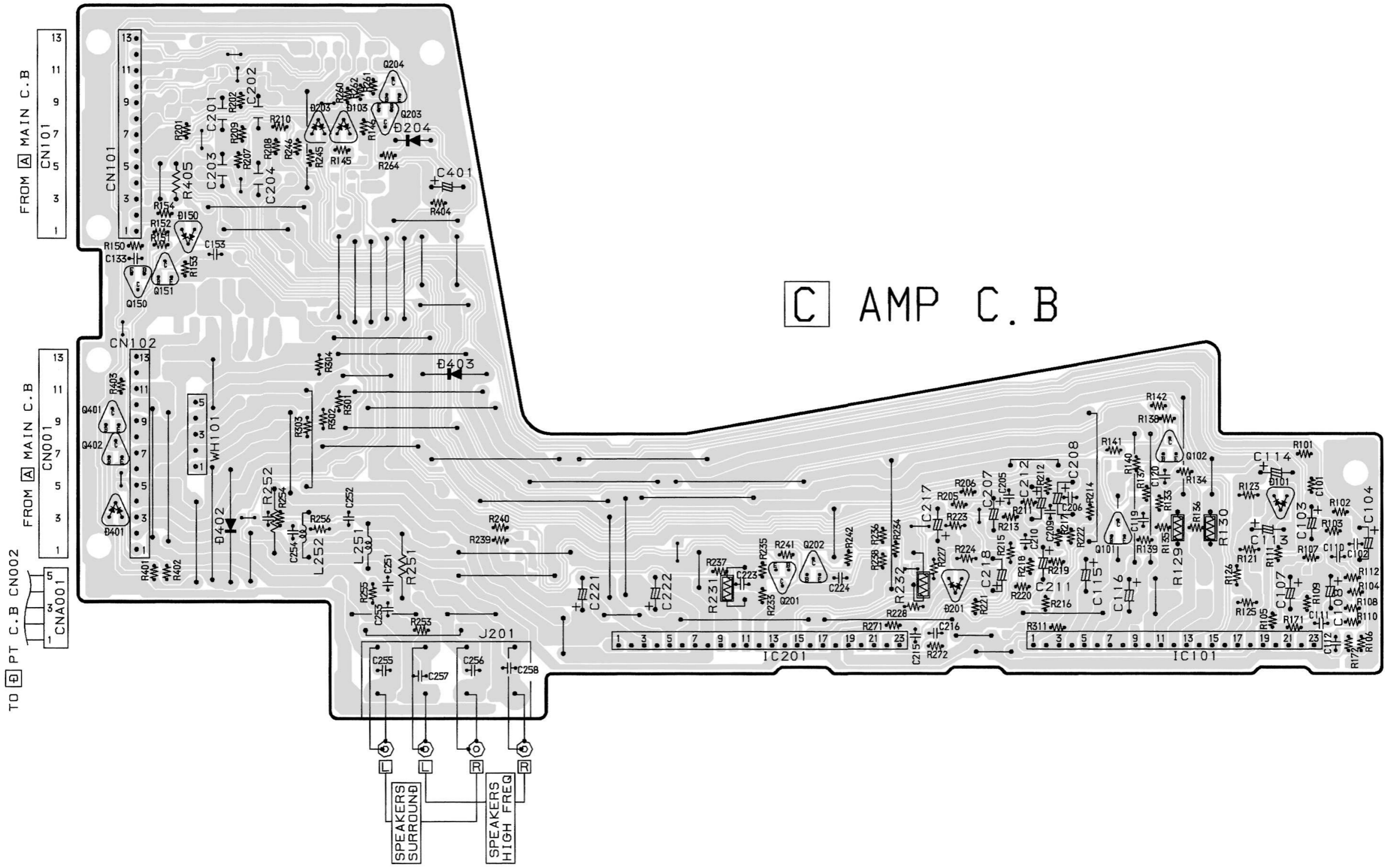

C AMP C.B

SCHEMATIC DIAGRAM - 5 (AMP)

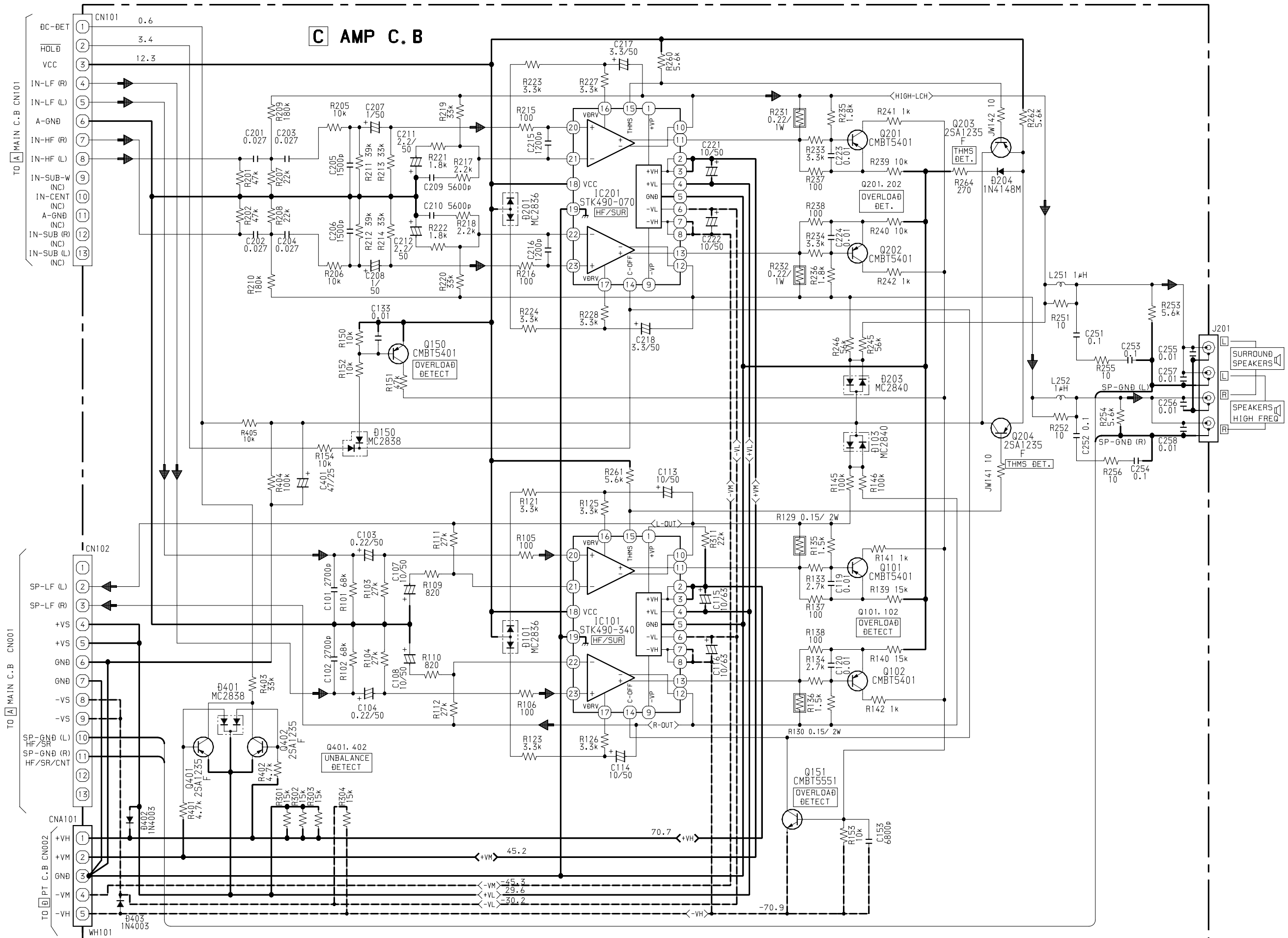

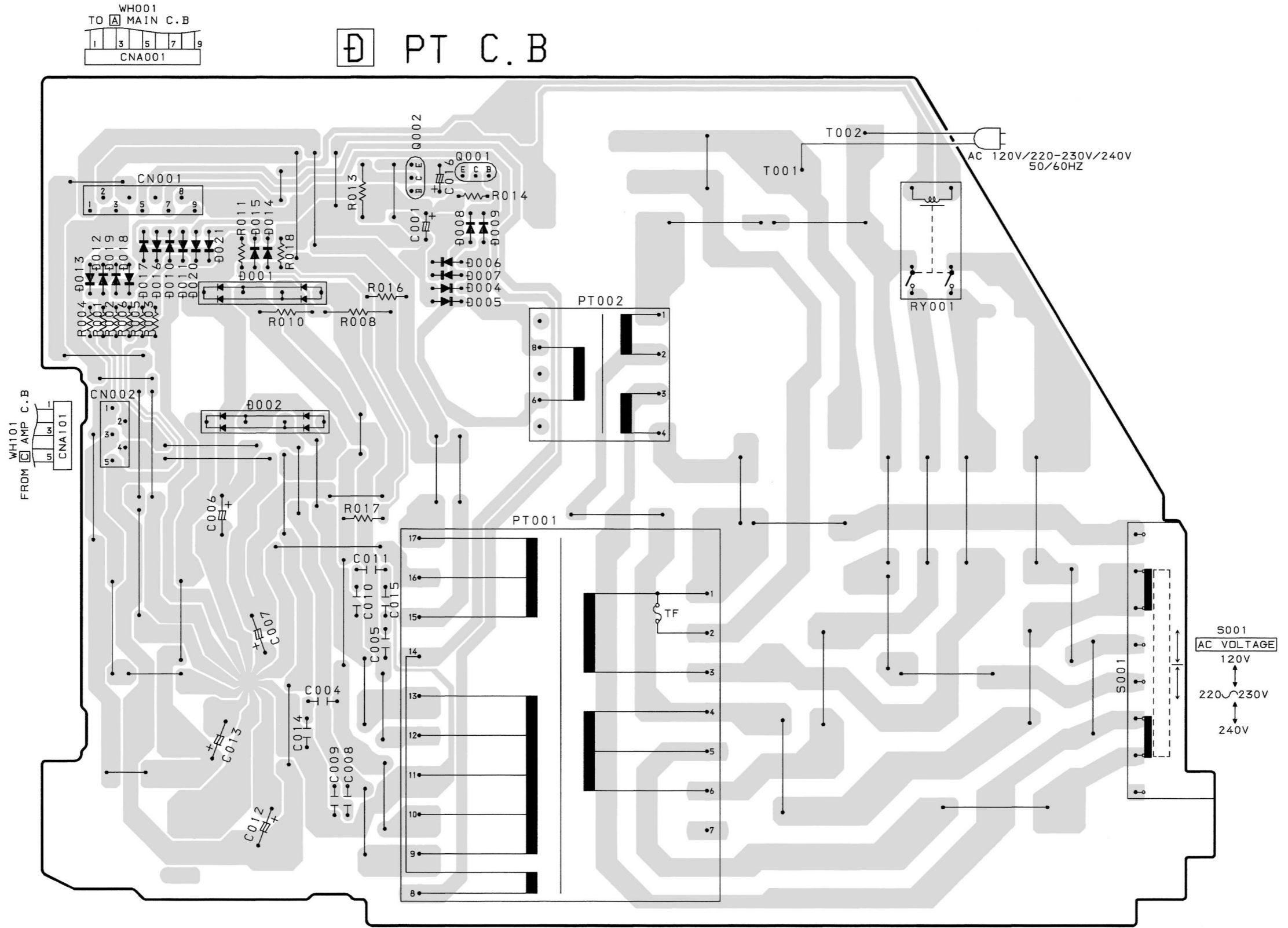

SCHEMATIC DIAGRAM-6 (PT)

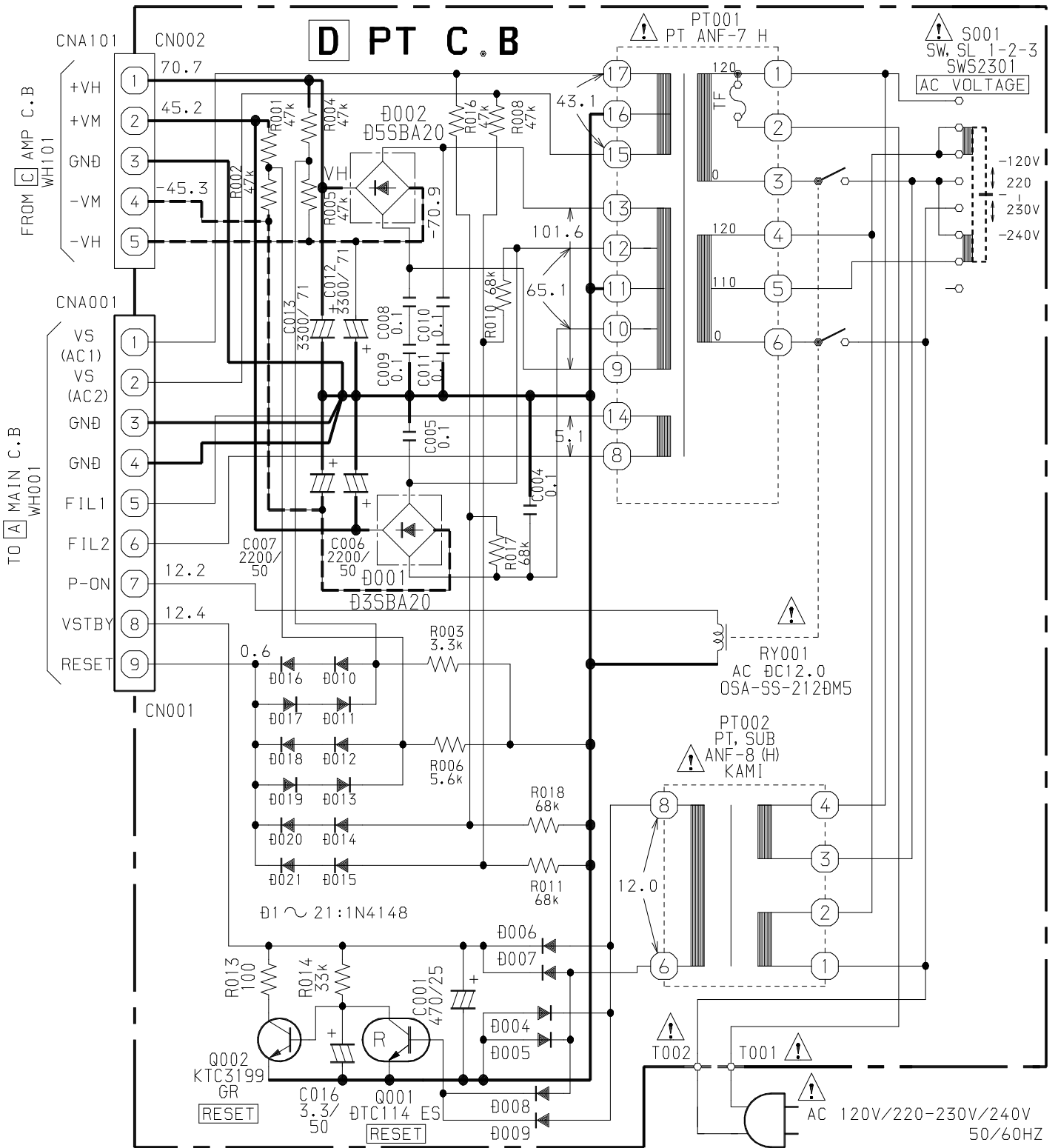

IC BLOCK DIAGRAM

IC, LA1844L-A

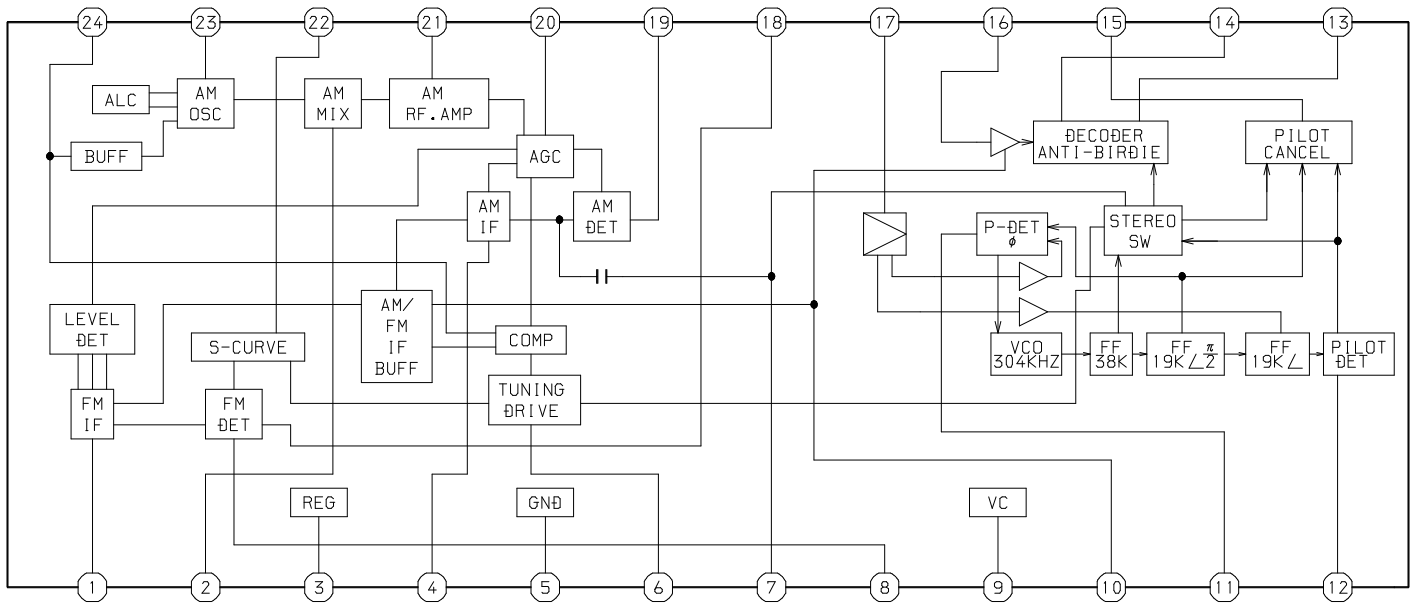

MECHANICAL PARTS LIST 1 / 1

REF. NO.	PART NO.	KANRI NO.	DESCRIPTION
19	8A-NF7-089-010		WINDOW,DISP LHK
47	8A-NF7-157-010		PANEL,REAR LH-F W/O SPC
△ 55	87-A80-157-010		AC CORD ASSY,E BLK CC
K	87-067-584-010		TAPPING SCREW, BVT2+3-6

COLOR NAME TABLE

Basic color symbol	Color	Basic color symbol	Color	Basic color symbol	Color
B	Black	C	Cream	D	Orange
G	Green	H	Gray	L	Blue
LT	Transparent Blue	N	Gold	P	Pink
R	Red	S	Silver	ST	Titan Silver
T	Brown	V	Violet	W	White
WT	Transparent White	Y	Yellow	YT	Transparent Yellow
LM	Metallic Blue	LL	Light Blue	GT	Transparent Green
LD	Dark Blue	DT	Transparent Orange	GM	Metallic Green
YM	Metallic Yellow	DM	Metallic Orange	PT	Transparent Pink

SPEAKER PARTS LIST SX-WNSZ70 (YLSKM)

REF. NO.	PART NO.	KANRI NO.	DESCRIPTION
1	8Z-NS6-606-110		SPKR, W 160
2	8A-NS7-604-010		SPKR, M 100
3	8A-NSY-608-010		SPKR, CERAMIC ASSY
4	8Z-NSY-003-010		CORD, BUSH
5	8A-NSJ-006-010		BADGE, AIWA S35
6	8A-NS7-017-010		PROTECTOR,
7	88-NS5-610-010		CORD, SPKR
8	88-NS5-611-010		CORD, SPKR B/L
9	8Z-NS6-021-010		FOOT,
10	8A-NS8-013-010		FASTENER, C
11	8A-NS7-001-010		PANEL, FR
12	8A-NS7-004-010		PANEL, DUCT
13	8A-NS7-005-010		GRILLE, FRAME ASSY

アイワ株式会社 〒110-8710 東京都台東区池之端1-2-11 ☎03(3827)3111 (代表)
AIWA CO.,LTD. 2-11, IKENOHATA 1-CHOME, TAITO-KU, TOKYO 110, JAPAN TEL:03 (3827) 3111