

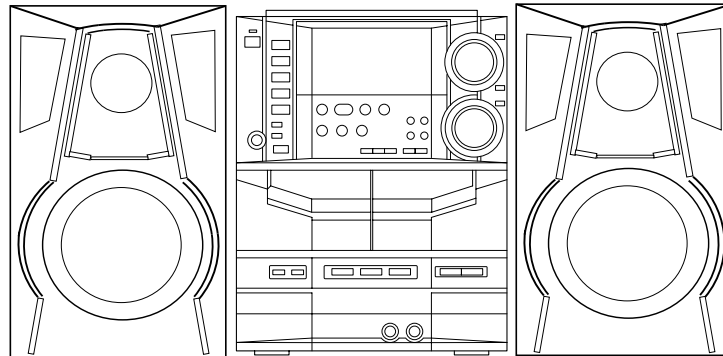

NSX-SZ80 LH
NSX-SZ83 LH
NSX-AJ80 U
NSX-SZ80E HA



SERVICE MANUAL

COMPACT DISC STEREO
CASSETTE RECEIVER

BASIC TAPE MECHANISM : 2ZM-3MK2 PR7NM
BASIC CD MECHANISM : AZG-1 ZD3RNDM

SYSTEM	CD CASSEIVER	MAIN SPEAKER	SATELLITE SPEAKER	REMOTE CONTROLLER
NSX-SZ80 (LH)	CX-NSZ80	SX-WNSZ80	SX-S80	RC-ZAS01
NSX-SZ83 (LH)	CX-NSZ83	SX-WNH83		
NSX-AJ80 (U)	CX-NAJ80	SX-WNAJ85		
NSX-SZ80E (HA)	CX-NSZ80E	SX-WNSZ80		

- If requiring information about the CD mechanism, see Service Manual of AZG-1 ZD3RNDM, (S/M Code No. 09-001-335-3N8).

aiwa

S/M Code No. 09-003-424-4R1

SPECIFICATIONS

<FM tuner section>

Tuning range	87.5 MHz to 108 MHz
Usable sensitivity (IHF)	13.2 dBf
Antenna terminals	75 ohms (unbalanced)

<AM tuner section>

Tuning range	530 kHz to 1710 kHz (10 kHz step) 531 kHz to 1602 kHz (9 kHz step)
Usable sensitivity	350 μ V/m
Antenna	Loop antenna

<Amplifier section>

Mid-high frequency amplifier

Power output	LH, HA: Rated 35 W + 35 W (6 ohms, T.H.D. 1 %, 1 kHz) Reference: 45 W + 45 W (6 ohms, T.H.D. 10 %, 1 kHz) U: 30 W + 30 W (200 Hz - 20 kHz, T.H.D. less than 1 %, 8 ohms) 0.1 % (25 W, 1 kHz, 8 ohms, DIN AUDIO)
Total harmonic distortion	

Low frequency amplifier

Power output	LH, HA: Rated 105 W + 105 W (6 ohms, T.H.D. 1 %, 120 Hz) Reference: 135 W + 135 W (6 ohms, T.H.D. 10 %, 120 Hz) U: 90 W + 90 W (50 Hz - 200 Hz, T.H.D. less than 1 %, 6 ohms) 0.1 % (75 W, 120 Hz, 6 ohms, DIN AUDIO)
Total harmonic distortion	

Satellite amplifier<U only>

Power output	5 W + 5 W (1 kHz, T.H.D. less than 1 %, 8 ohms)
Total harmonic distortion	0.1 % (3 W, 1 kHz, 8 ohms, DIN AUDIO)

Inputs

VIDEO/AUX: 316 mV (adjustable)
MD: 316 mV (adjustable)
MIC: 1.0 mV (10 k ohms)

Outputs

SPEAKERS HIGH FREQ:
accept speakers of 8 ohms or more
SPEAKERS LOW FREQ:
accept speakers of 6 ohms or more
SATELLITE SPEAKERS:
accept speakers of 8 ohms or more
SURROUND SPEAKERS:
accept speakers of 8 ohms to 16 ohms
LINE OUT: 210 mV
PHONES (stereo jack): accepts
headphones of 32 ohms or more

<Cassette deck section>

Track format

4 tracks, 2 channels stereo

Frequency response

CrO₂ tape: 50 Hz – 16000 Hz
NORMAL tape: 50 Hz – 15000 Hz
AC bias

Recording system

Heads

Deck 1: Playback head x 1
Deck 2: Recording/Playback head
x 1, erase head x 1

<Compact disc player section>

Laser	Semiconductor laser (λ =780 nm)
D-A converter	1 bit dual
Signal-to-noise ratio	85 dB (1 kHz, 0 dB)
Harmonic distortion	0.05 % (1 kHz, 0 dB)
Wow and flutter	Unmeasurable

<General>

Power requirements	U: 120 V AC, 60 Hz LH, HA: 120 V/220-230 V/240 V AC (switchable), 50/60 Hz
---------------------------	--

Power consumption

U: 165 W
LH, HA: 245 W

Power consumption in standby mode

If the power-economizing mode is
ECO OFF:

LH, HA: 29.5 W
U: 27.5 W

If the power-economizing mode is
ECO ON or ECO AUTO: 0.9 W

Dimensions of main unit

(W x H x D)
260 x 329 x 389.6 mm

(10 ¹/₄ X 13 X 15 ³/₈ in.)

Weight of main unit
11.8 kg (26 lbs.)

<Speaker system SX–WNH83 / SX–WNSZ80 / SX–WNAJ85>

Speaker system
3 way, built-in subwoofer (magnetic
shielded type)

Speaker units

Subwoofer:
200 mm (7 ⁷/₈ in.) cone type
Full range:
120 mm (4 ³/₄ in.) cone type
Super tweeter:
20 mm (¹³/₁₆ in.) ceramic type
6 ohms/8 ohms

Impedance

87 dB/W/m

Output sound pressure level

Dimensions (W x H x D)
SX–WNH83 / WNAJ85:

240 x 324 x 285 mm

(9 ¹/₂ X 12 ⁷/₈ X 11 ¹/₄ in.)

SX–WNSZ80: 240 x 384 x 310 mm

5.8 kg (12 lbs. 13 oz.)

Weight

<Satellite speaker SX–S80>

Speaker system
Full range (magnetic shielded type)

Speakers units

80 mm cone type

Impedance

8 ohms

Output sound pressure level

87 dB/W/m

Dimensions (W x H x D)

100 x 327 x 105 mm

(4 X 12 ⁷/₈ X 4 ¹/₄ in.)(with pedestal)

100 x 190 x 81 mm

(4 X 7 ¹/₂ X 3 ¹/₄ in.)(without pedestal)

Weight

0.6 kg (1 lbs. 5 oz.)

• Design and specifications are subject to change without notice.

• The word "BBE" and the "BBE symbol" are trademarks of BBE
Sound, Inc.
Under license from BBE Sound, Inc.

PROTECTION OF EYES FROM LASER BEAM DURING SERVICING

This set employs laser. Therefore, be sure to follow carefully the instructions below when servicing.

WARNING!!

WHEN SERVICING, DO NOT APPROACH THE LASER EXIT WITH THE EYE TOO CLOSELY. IN CASE IT IS NECESSARY TO CONFIRM LASER BEAM EMISSION. BE SURE TO OBSERVE FROM A DISTANCE OF MORE THAN 30cm FROM THE SURFACE OF THE OBJECTIVE LENS ON THE OPTICAL PICK-UP BLOCK.

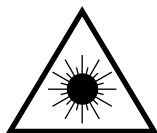

- Caution: Invisible laser radiation when open and interlocks defeated avoid exposure to beam.
- Advarsel: Usynlig laserstråling ved åbning, når sikkerhedsafbrydere er ude af funktion. Undgå udsættelse for stråling.

VAROITUS!

Laitteen Käyttäminen muulla kuin tässä käyttöohjeessa mainitulla tavalla saattaa altistaa käyttäjän turvallisuusluokan 1 ylittävälle näkymättömälle lasersäteilylle.

WARNING!

Om apparaten används på annat sätt än vad som specificeras i denna bruksanvisning, kan användaren utsättas för osynlig laserstrålning, som överskrider gränsen för laserklass 1.

CAUTION

Use of controls or adjustments or performance of procedures other than those specified herein may result in hazardous radiation exposure.

ATTENTION

L'utilisation de commandes, réglages ou procédures autres que ceux spécifiés peut entraîner une dangereuse exposition aux radiations.

ADVARSEL

Usynlig laserstråling ved åbning, når sikkerhedsafbrydere er ude af funktion. Undgå udsættelse for stråling.

This Compact Disc player is classified as a CLASS 1 LASER product.

The CLASS 1 LASER PRODUCT label is located on the rear exterior.

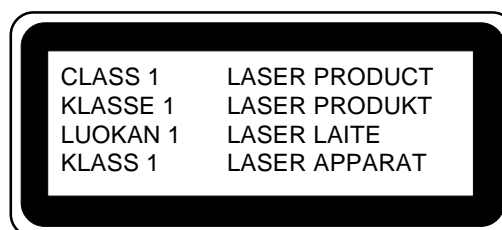

Precaution to replace Optical block

(KSS-213F)

Body or clothes electrostatic potential could ruin laser diode in the optical block. Be sure ground body and workbench, and use care the clothes do not touch the diode.

- 1) After the connection, remove solder shown in right figure.

PICK-UP Assy P.C.B

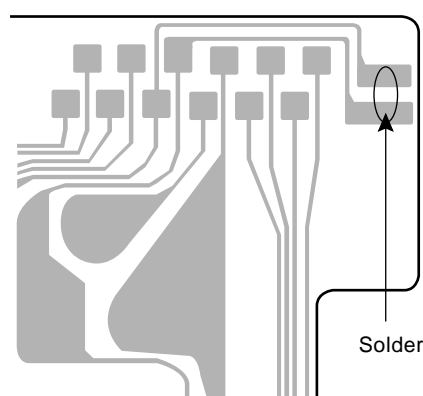

NOTE ON BEFORE STARTING REPAIR

1. Forced discharge of electrolytic capacitor of power supply block

When repair is going to be attempted in the set that uses relay circuit in the power supply block, electric potential is kept charged across the electrolytic capacitors (C101, 102) even though AC power cord is removed. If repair is attempted in this condition, secondary defect can occur.

In order to prevent the secondary trouble, perform the following measures before starting repair work.

Discharge procedure

- ① Remove the AC power cord.
- ② Connect a discharging resistor at an end of lead wire that has clips at both ends. Connect the other end of the lead wire to metal chassis.
- ③ Contact the other end of the discharging resistor to the positive (+) side (+VH) of C101. (For two seconds)
- ④ Contact the same end of the discharging resistor as step ③ to the negative (-) side (-VH) of C102 in the same way. (For two seconds)
- ⑤ Check that voltage across C101 and C102 has decreased to 1 V or less using a multimeter or an oscilloscope.

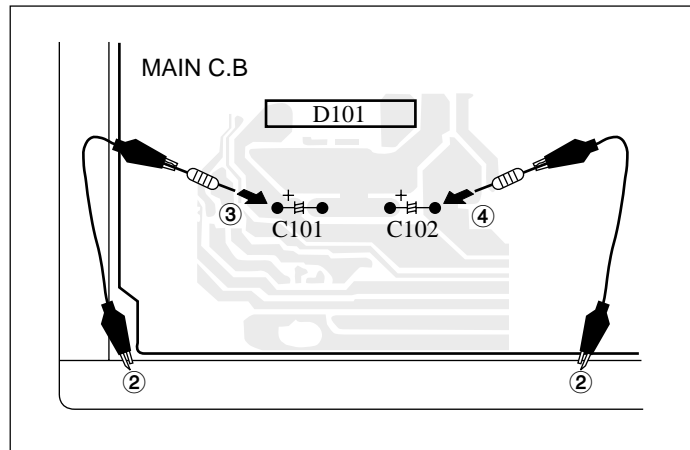

Fig-1

Select a discharging resistor referring to the following table.

Charging voltage (V) (C101, 102)	Discharging resistor (Ω)	Rated power (W)	Parts number
25-48	100	3	87-A00-247-090
49-140	220	5	87-A00-232-090

Note: The reference numbers (C101, C102) of the electrolytic capacitors can change depending on the models. Be sure to check the reference numbers of the charging capacitors on schematic diagram before starting the discharging work.

2. Check items before exchanging the MICROCOMPUTER

Be sure to check the following items before exchanging the MICROCOMPUTER. Exchange the MICROCOMPUTER after confirming that the MICROCOMPUTER is surely defective.

2-1. Regarding the HOLD terminal of the MICROCOMPUTER

When the HOLD terminal (INPUT) of the MICROCOMPUTER is "H", the MICROCOMPUTER is judged to be operating correctly. When this terminal is "L", the main power cannot be turned on. Therefore, be sure to check the terminal voltage of the HOLD terminal before exchange.

When the MICROCOMPUTER is not defective, the HOLD terminal can also go "L" when the POWER AMPLIFIER has any abnormalities that triggers the abnormality detection circuit on the MAIN C. B. that sets the HOLD terminal to "L".

- Good or no good judgement of the MICROCOMPUTER

- ① Turn on the AC main power.
- ② Confirm that the main power is turned on and the HOLD terminal of the MICROCOMPUTER keeps the "H" level or not.
- ③ When the HOLD terminal is "L" level, the abnormality detection circuit is judged to be working correctly and the MICROCOMPUTER is judged to be good.

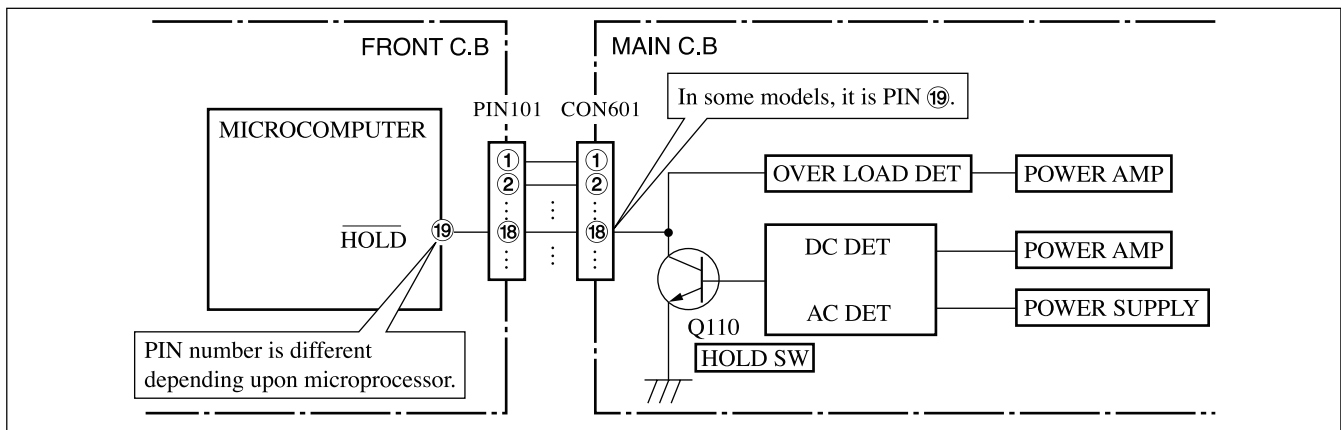

Fig-2-1

In such a case, check also if the POWER AMPLIFIER circuit or power supply circuit has any abnormalities or not.

2-2. Regarding reset

There are cases that the machine does not work correctly because the MICROCOMPUTER is not reset even though the AC power cord is re-inserted, or the software reset (pressing the STOP key + POWER key) is performed.

When the above described phenomenon occurs, it can lead to wrong judgement as if the MICROCOMPUTER is defective and to exchange the MICROCOMPUTER. In such a case, perform the forced-reset by the following procedure and check good or no good of the MICROCOMPUTER.

- ① Remove the AC power cord.

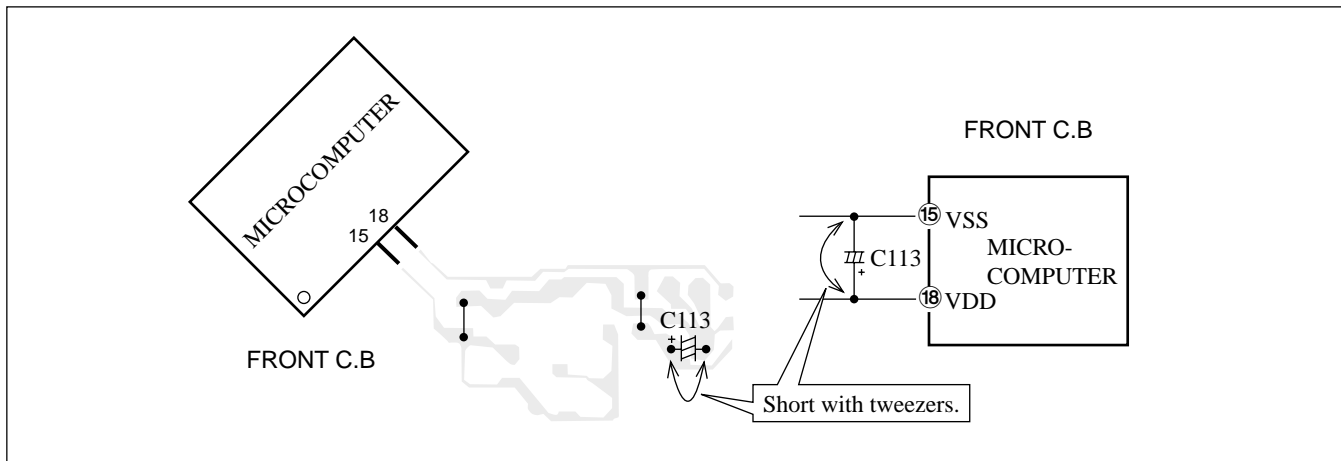

Fig-2-2

- ② Short both ends of the electrolytic capacitor C113 that is connected to VDD of the MICROCOMPUTER with tweezers.
- ③ Connect the AC power cord again. If the MICROCOMPUTER returns to the normal operation, the MICROCOMPUTER is good.

Note: The reference number or MICROCOMPUTER pin number of transistor (Q110) and electrolytic capacitor (C113) can change depending on the models. Be sure to check the reference numbers on schematic diagram before starting the discharging work.

2-3. Confirmation of soldering state of MICROCOMPUTER

Check the soldering state of the MICROCOMPUTER in addition to the above described procedures. Be sure to exchange the MICROCOMPUTER after surely confirming that the trouble is not caused by poor soldering but the MICROCOMPUTER itself.

ELECTRICAL MAIN PARTS LIST

REF. NO.	PART NO.	KANRI NO.	DESCRIPTION	REF. NO.	PART NO.	KANRI NO.	DESCRIPTION
IC							
	8A-NF6-610-030		C-IC,LC87654V-5P35	C22	87-016-658-000		CAP,E 4700-35 M SMG
	87-A21-418-010		IC,STK490-340	C25	87-010-382-080		CAP, ELECT 22-25V
	87-A21-018-040		C-IC,M65849BFP631D	C26	87-010-382-080		CAP, ELECT 22-25V<EXCEPT 80U>
	87-A21-396-010		IC,STK490-040<80U>	C26	87-010-383-080		CAP, ELECT 33-25V<80U>
	87-A21-397-010		IC,STK490-070<EXCEPT 80U>	C27	87-010-382-080		CAP, ELECT 22-25V
	87-A20-914-010		IC,SPS-442-1-F	C28	87-010-382-080		CAP, ELECT 22-25V<EXCEPT 80U>
	87-A20-783-040		C-IC,BA7762AFS	C28	87-010-383-080		CAP, ELECT 33-25V<80U>
	87-A21-577-040		C-IC,M61506FP	C31	87-010-263-080		CAP, ELECT 100-10V
	87-A21-021-040		C-IC,BU2099FV	C32	87-010-197-080		CAP, CHIP 0.01 DM
	87-070-289-040		IC,BU 2092F	C33	87-010-263-080		CAP, ELECT 100-10V<80U>
	87-A21-452-030		C-IC,BD3876KS2	C34	87-010-247-080		CAP, ELECT 100-50V
	87-A21-051-040		C-IC,BU9990-03FS<EXCEPT 80U>	C35	87-010-260-080		CAP, ELECT 47-25V
	87-A21-415-010		IC,LA1843	C36	87-010-381-080		CAP, ELECT 330-16V
	87-070-127-110		IC,LC72131 D	C38	87-010-384-080		CAP, ELECT 100-25V
	87-020-454-010		IC,DN 6851	C39	87-010-384-080		CAP, ELECT 100-25V
TRANSISTOR							
	87-026-245-080		TR,DTC114ES	C40	87-010-197-080		CAP, CHIP 0.01 DM
	87-A30-198-080		TR,KTC3199GR	C60	87-010-403-080		CAP, ELECT 3.3-50V
	87-A30-075-080		C-TR,2SA1235F	C80	87-010-401-080		CAP, ELECT 1-50V<EXCEPT 80U>
	87-A30-318-080		TR,CSA952K	C81	87-010-374-080		CAP, ELECT 47-10V<EXCEPT 80U>
	89-213-702-010		TR,2SB1370 (1.8W)	C82	87-010-260-080		CAP, ELECT 47-25V<EXCEPT 80U>
	87-A30-076-080		C-TR,2SC3052F	C104	87-010-196-080		CHIP CAPACITOR,0.1-25
	87-026-610-080		TR,KTC3198GR	C105	87-010-196-080		CHIP CAPACITOR,0.1-25
	87-026-609-080		TR,KTA1266GR	C111	87-010-545-080		CAP, ELECT 0.22-50V
	87-A30-087-080		C-FET,2SK2158	C112	87-010-545-080		CAP, ELECT 0.22-50V
	87-A30-107-070		C-TR,CMBT5401	C113	87-010-545-080		CAP, ELECT 0.22-50V
	87-A30-468-080		C-TR,KRC102S-RTK	C114	87-010-545-080		CAP, ELECT 0.22-50V
	87-A30-074-080		C-TR,RT1P141C	C115	87-010-546-080		CAP, ELECT 0.33-50V
	87-A30-269-040		C-FET,2SJ461-T1	C116	87-010-546-080		CAP, ELECT 0.33-50V
	87-A30-106-040		C-TR,CMBT5551	C121	87-010-546-080		CAP, ELECT 0.33-50V
	87-A30-086-040		C-TR,CSD1306E	C122	87-010-546-080		CAP, ELECT 0.33-50V
	87-A30-190-080		TR,CC5551	C171	87-012-368-080		C-CAP,S 0.1-50 F
	89-420-613-010		TR,2SD2061F	C172	87-012-368-080		C-CAP,S 0.1-50 F
	89-213-703-010		TR,2SB1370F	C173	87-012-368-080		C-CAP,S 0.1-50 F
	87-A30-063-080		C-TR,KRA104S	C174	87-012-368-080		C-CAP,S 0.1-50 F
	87-A30-086-070		C-TR,CSD1306E	C301	87-010-318-080		C-CAP,S 47P-50 J CH
	87-A30-329-080		TR,CD1585BC	C302	87-010-318-080		C-CAP,S 47P-50 J CH
	89-327-143-080		TR,2SC2714 (0.1W)	C303	87-012-157-080		C-CAP,S 330P-50 CH
	87-A30-489-080		C-TR,KRA107S	C304	87-012-157-080		C-CAP,S 330P-50 CH
	87-A30-234-080		TR,CSC4115BC	C305	87-012-157-080		C-CAP,S 330P-50 CH
	87-026-463-080		TR,2SA933S	C306	87-012-157-080		C-CAP,S 330P-50 CH
	87-A40-673-090		DIODE,D10XB20	C307	87-010-196-080		CHIP CAPACITOR,0.1-25
	87-A40-547-090		DIODE,D5SBA20	C309	87-010-196-080		CHIP CAPACITOR,0.1-25
	87-020-465-080		DIODE,1SS133	C310	87-010-196-080		CHIP CAPACITOR,0.1-25
	87-A40-553-080		DIODE,1N4003 LES	C311	87-010-198-080		CAP, CHIP 0.022
	87-A40-784-080		ZENER,UZ39BSB	C312	87-010-198-080		CAP, CHIP 0.022
	87-A40-764-080		ZENER,UZ10BSC	C313	87-010-179-080		CAP,CHIP S B1200P
	87-A40-313-080		C-DIODE,MC 2840	C314	87-010-179-080		CAP,CHIP S B1200P
	87-A40-270-080		C-DIODE,MC2838	C315	87-010-179-080		CAP,CHIP S B1200P
	87-A40-269-080		C-DIODE,MC2836	C316	87-010-179-080		CAP,CHIP S B1200P
	87-A40-768-080		ZENER,UZ16BSA	C321	87-012-142-080		CAP, S 0.33-16
	87-A40-752-080		ZENER,UZ6.2BSC	C322	87-012-142-080		CAP, S 0.33-16
	87-A40-748-080		ZENER,UZ5.6BSA	C324	87-010-260-080		CAP, ELECT 47-25V
	87-A40-802-080		ZENER,UZ5.1BSC	C325	87-010-370-080		CAP,E 330-6.3 SME
	87-A40-747-080		ZENER,UZ5.1BSB	C327	87-010-404-080		CAP, ELECT 4.7-50V
	87-A40-745-080		ZENER,UZ4.7BSA	C328	87-010-404-080		CAP, ELECT 4.7-50V
	87-A40-749-080		ZENER,UZ5.6BSB<EXCEPT 80U>	C332	87-010-196-080		CHIP CAPACITOR,0.1-25
	87-017-149-080		ZENER,HZS6A2L	C335	87-010-401-080		CAP, ELECT 1-50V
DIODE							
	87-A40-673-090		DIODE,D10XB20	C336	87-010-401-080		CAP, ELECT 1-50V
	87-A40-547-090		DIODE,D5SBA20	C337	87-010-196-080		CHIP CAPACITOR,0.1-25
	87-020-465-080		DIODE,1SS133	C339	87-010-196-080		CHIP CAPACITOR,0.1-25
	87-A40-553-080		DIODE,1N4003 LES	C340	87-010-196-080		CHIP CAPACITOR,0.1-25
	87-A40-784-080		ZENER,UZ39BSB	C351	87-012-140-080		CAP 470P
	87-A40-764-080		ZENER,UZ10BSC	C352	87-012-140-080		CAP 470P
	87-A40-313-080		C-DIODE,MC 2840	C354	87-010-175-080		CAP 560P
	87-A40-270-080		C-DIODE,MC2838	C355	87-010-178-080		CHIP CAP 1000P
	87-A40-269-080		C-DIODE,MC2836	C356	87-010-260-080		CAP, ELECT 47-25V
	87-A40-768-080		ZENER,UZ16BSA	C357	87-010-197-080		CAP, CHIP 0.01 DM
	87-A40-752-080		ZENER,UZ6.2BSC	C358	87-010-183-080		C-CAP,S 2700P-50 B
	87-A40-748-080		ZENER,UZ5.6BSA	C359	87-010-183-080		C-CAP,S 2700P-50 B
	87-A40-802-080		ZENER,UZ5.1BSC	C360	87-010-183-080		C-CAP,S 2700P-50 B
	87-A40-747-080		ZENER,UZ5.1BSB				
	87-A40-745-080		ZENER,UZ4.7BSA				
	87-A40-749-080		ZENER,UZ5.6BSB<EXCEPT 80U>				
	87-017-149-080		ZENER,HZS6A2L				
MAIN C.B							
C3	87-012-368-080		C-CAP,S 0.1-50 F	C356	87-010-260-080		CAP, ELECT 47-25V
C4	87-012-368-080		C-CAP,S 0.1-50 F	C357	87-010-197-080		CAP, CHIP 0.01 DM
C21	87-016-658-000		CAP,E 4700-35 M SMG	C358	87-010-183-080		C-CAP,S 2700P-50 B

REF. NO.	PART NO.	KANRI NO.	DESCRIPTION	REF. NO.	PART NO.	KANRI NO.	DESCRIPTION
C370	87-010-196-080		CHIP CAPACITOR,0.1-25	C641	87-010-401-080		CAP, ELECT 1-50V
C373	87-016-083-080		C-CAP,S 0.15-16 RK	C642	87-010-401-080		CAP, ELECT 1-50V
C374	87-016-083-080		C-CAP,S 0.15-16 RK	C643	87-010-196-080		CHIP CAPACITOR,0.1-25
C378	87-010-196-080		CHIP CAPACITOR,0.1-25	C644	87-010-401-080		CAP, ELECT 1-50V
C379	87-010-382-080		CAP, ELECT 22-25V	C671	87-010-322-080		C-CAP,S 100P-50 CH
C380	87-010-382-080		CAP, ELECT 22-25V	C672	87-010-322-080		C-CAP,S 100P-50 CH
C381	87-010-197-080		CAP, CHIP 0.01 DM	C673	87-010-197-080		CAP, CHIP 0.01 DM
C382	87-010-312-080		C-CAP,S 15P-50 CH	C679	87-010-196-080		CHIP CAPACITOR,0.1-25
C383	87-010-197-080		CAP, CHIP 0.01 DM	C680	87-010-197-080		CAP, CHIP 0.01 DM
C384	87-010-402-080		CAP, ELECT 2.2-50V	C682	87-010-196-080		CHIP CAPACITOR,0.1-25
C386	87-010-196-080		CHIP CAPACITOR,0.1-25	C771	87-010-263-080		CAP, ELECT 100-10V
C387	87-012-145-080		CAP, CHIP S 270P CH	C772	87-010-197-080		CAP, CHIP 0.01 DM
C388	87-012-156-080		C-CAP,S 220P-50 CH	C773	87-010-184-080		CHIP CAPACITOR 3300P(K)
C391	87-010-319-080		C-CAP,S 56P-50 CH	C774	87-010-184-080		CHIP CAPACITOR 3300P(K)
C392	87-010-319-080		C-CAP,S 56P-50 CH	C779	87-A10-679-080		C-CAP,S 3300P-50 JR
C393	87-010-319-080		C-CAP,S 56P-50 CH	C780	87-A10-679-080		C-CAP,S 3300P-50 JR
C394	87-010-319-080		C-CAP,S 56P-50 CH	C782	87-010-197-080		CAP, CHIP 0.01 DM
C501	87-010-263-080		CAP, ELECT 100-10V	C783	87-010-197-080		CAP, CHIP 0.01 DM
C502	87-010-196-080		CHIP CAPACITOR,0.1-25	C784	87-010-197-080		CAP, CHIP 0.01 DM
C503	87-012-393-080		C-CAP,S 0.22-16 R K	C785	87-010-197-080		CAP, CHIP 0.01 DM
C504	87-012-393-080		C-CAP,S 0.22-16 R K	C786	87-010-197-080		CAP, CHIP 0.01 DM
C505	87-012-141-080		CHIP-CAPACITOR,0.22-16F	C788	87-010-149-080		C-CAP,S 5P-50 CH
C506	87-010-184-080		CHIP CAPACITOR 3300P(K)	C789	87-A10-592-080		C-CAP,S 0.015-50 J B
C507	87-010-177-080		C-CAP,S 820P-50 SL	C790	87-A10-592-080		C-CAP,S 0.015-50 J B
C508	87-016-669-080		C-CAP,S 0.1-25 K B	C791	87-010-196-080		CHIP CAPACITOR,0.1-25
C509	87-016-669-080		C-CAP,S 0.1-25 K B	C792	87-010-197-080		CAP, CHIP 0.01 DM
C510	87-010-184-080		CHIP CAPACITOR 3300P(K)	C793	87-010-404-080		CAP, ELECT 4.7-50V
C511	87-010-177-080		C-CAP,S 820P-50 SL	C795	87-010-197-080		CAP, CHIP 0.01 DM
C512	87-012-141-080		CHIP-CAPACITOR,0.22-16F	C796	87-010-197-080		CAP, CHIP 0.01 DM
C513	87-010-544-080		CAP, ELECT 0.1-50V	C797	87-010-405-080		CAP, ELECT 10-50V
C514	87-010-374-080		CAP, ELECT 47-10V	C798	87-010-197-080		CAP, CHIP 0.01 DM
C515	87-010-401-080		CAP, ELECT 1-50V	C799	87-010-407-080		CAP, ELECT 33-50V
C516	87-010-401-080		CAP, ELECT 1-50V	C800	87-012-369-080		C-CAP,S 0.047-50F
C517	87-010-183-080		C-CAP,S 2700P-50 B	C801	87-010-403-080		CAP, ELECT 3.3-50V
C518	87-010-183-080		C-CAP,S 2700P-50 B	C802	87-012-369-080		C-CAP,S 0.047-50F
C531	87-010-405-080		CAP, ELECT 10-50V	C803	87-010-198-080		CAP, CHIP 0.022
C532	87-010-196-080		CHIP CAPACITOR,0.1-25	C804	87-010-263-080		CAP, ELECT 100-10V
C533	87-010-196-080		CHIP CAPACITOR,0.1-25	C807	87-010-400-080		CAP, ELECT 0.47-50V
C534	87-012-156-080		C-CAP,S 220P-50 CH	C808	87-010-401-080		CAP, ELECT 1-50V
C535	87-010-178-080		CHIP CAP 1000P	C809	87-010-401-080		CAP, ELECT 1-50V
C536	87-010-196-080		CHIP CAPACITOR,0.1-25	C810	87-010-196-080		CHIP CAPACITOR,0.1-25
C538	87-010-318-080		C-CAP,S 47P-50 CH	C811	87-010-403-080		CAP, ELECT 3.3-50V
C541	87-010-178-080		CHIP CAP 1000P	C812	87-010-403-080		CAP, ELECT 3.3-50V
C609	87-010-181-080		CAP,CHIP S 1800P	C814	87-010-197-080		CAP, CHIP 0.01 DM
C610	87-010-181-080		CAP,CHIP S 1800P	C815	87-010-400-080		CAP, ELECT 0.47-50V
C611	87-010-956-080		CHIP-CAP,S 0.068-25B	C816	87-010-400-080		CAP, ELECT 0.47-50V
C612	87-016-369-080		C-CAP,S 0.033-25 B K	C819	87-010-179-080		CAP,CHIP S B1200P
C613	87-010-197-080		CAP, CHIP 0.01 DM	C820	87-010-179-080		CAP,CHIP S B1200P
C614	87-016-669-080		C-CAP,S 0.1-25 K B	C821	87-010-405-080		CAP, ELECT 10-50V
C616	87-010-184-080		CHIP CAPACITOR 3300P(K)	C823	87-010-177-080		C-CAP,S 820P-50 SL
C617	87-012-369-080		C-CAP,S 0.047-50F	C824	87-010-405-080		CAP, ELECT 10-50V
C618	87-010-401-080		CAP, ELECT 1-50V	C825	87-010-596-080		CAP, S 0.047-16
C619	87-010-263-080		CAP, ELECT 100-10V	C842	87-010-197-080		CAP, CHIP 0.01 DM
C620	87-016-669-080		C-CAP,S 0.1-25 K B	C843	87-010-197-080		CAP, CHIP 0.01 DM
C621	87-010-197-080		CAP, CHIP 0.01 DM	C844	87-010-197-080		CAP, CHIP 0.01 DM
C623	87-010-401-080		CAP, ELECT 1-50V	C845	87-010-197-080		CAP, CHIP 0.01 DM
C624	87-010-401-080		CAP, ELECT 1-50V	C846	87-010-197-080		CAP, CHIP 0.01 DM
C626	87-010-596-080		CAP, S 0.047-16	C847	87-010-197-080		CAP, CHIP 0.01 DM
C627	87-010-400-080		CAP, ELECT 0.47-50V	C848	87-010-197-080		CAP, CHIP 0.01 DM
C628	87-010-400-080		CAP, ELECT 0.47-50V	C849	87-010-197-080		CAP, CHIP 0.01 DM
C629	87-010-596-080		CAP, S 0.047-16	C850	87-010-260-080		CAP, ELECT 47-25V
C630	87-010-383-080		CAP, ELECT 33-25V	C851	87-010-197-080		CAP, CHIP 0.01 DM
C631	87-010-185-080		C-CAP,S 3900P-50 B	C852	87-010-197-080		CAP, CHIP 0.01 DM
C632	87-010-185-080		C-CAP,S 3900P-50 B	C853	87-010-197-080		CAP, CHIP 0.01 DM
C634	87-010-196-080		CHIP CAPACITOR,0.1-25	C858	87-010-196-080		CHIP CAPACITOR,0.1-25
C635	87-A10-307-080		CAP,M 0.1-50 J	C859	87-010-196-080		CHIP CAPACITOR,0.1-25
C636	87-A10-307-080		CAP,M 0.1-50 J	C860	87-010-197-080		CAP, CHIP 0.01 DM
C637	87-A10-307-080		CAP,M 0.1-50 J	C959	87-010-196-080		CHIP CAPACITOR,0.1-25
C638	87-A10-307-080		CAP,M 0.1-50 J	C960	87-010-196-080		CHIP CAPACITOR,0.1-25
C639	87-010-405-080		CAP, ELECT 10-50V	C961	87-010-152-080		C-CAP,S 8P-50 CH

REF. NO.	PART NO.	KANRI NO.	DESCRIPTION	REF. NO.	PART NO.	KANRI NO.	DESCRIPTION
C963	87-015-785-080		CHIP CAPACITOR, 0.1FZ-25Z	C105	87-010-415-040		CAP,E 10-50 5L
C971	87-010-381-080		CAP, ELECT 330-16V	C106	87-010-493-040		CAP,E 0.47-50 GAS
C972	87-010-404-080		CAP, ELECT 4.7-50V	C107	87-A10-189-040		CAP,E 220-10
C973	87-010-197-080		CAP, CHIP 0.01 DM	C108	87-A10-189-040		CAP,E 220-10
C974	87-010-197-080		CAP, CHIP 0.01 DM	C109	87-010-196-080		CHIP CAPACITOR,0.1-25
C979	87-010-322-080		C-CAP,S 100P-50 CH	C110	87-010-178-080		CHIP CAP 1000P
C981	87-010-260-080		CAP, ELECT 47-25V	C112	87-012-368-080		C-CAP,S 0.1-50 F
C982	87-010-196-080		CHIP CAPACITOR,0.1-25	C113	87-A10-354-080		C-CAP,S 0.047-50 K B
C983	87-010-197-080		CAP, CHIP 0.01 DM	C114	87-010-196-080		CHIP CAPACITOR,0.1-25
C984	87-010-197-080		CAP, CHIP 0.01 DM	C115	87-010-196-080		CHIP CAPACITOR,0.1-25
C987	87-010-197-080		CAP, CHIP 0.01 DM	C116	87-010-196-080		CHIP CAPACITOR,0.1-25
C991	87-010-312-080		C-CAP,S 15P-50 CH	C118	87-012-145-080		CAP, CHIP S 270P CH
C992	87-010-312-080		C-CAP,S 15P-50 CH	C180	87-010-178-080		CHIP CAP 1000P
C993	87-010-178-080		CHIP CAP 1000P	C181	87-010-178-080		CHIP CAP 1000P
C995	87-010-178-080		CHIP CAP 1000P	C202	87-012-156-080		C-CAP,S 220P-50 CH
C997	87-010-196-080		CHIP CAPACITOR,0.1-25	C203	87-010-322-080		C-CAP,S 100P-50 CH
C998	87-010-260-080		CAP, ELECT 47-25V	C204	87-012-157-080		C-CAP,S 330P-50 CH
C999	87-A11-155-080		CAP,TC U 0.01-16 Z F	C205	87-012-156-080		C-CAP,S 220P-50 CH
CF831	87-008-261-010		FILTER, SFE10.7MA5-A	C214	87-010-322-080		C-CAP,S 100P-50 CH
CF832	87-008-261-010		FILTER, SFE10.7MA5-A	C215	87-010-322-080		C-CAP,S 100P-50 CH
CN1	87-A60-996-010		CONN,13P V BLK TAC-L13X-A3	C216	87-010-177-080		C-CAP,S 820P-50 SL
CN91	87-A60-109-010		CONN,2P V S2M-2W<EXCEPT 80U>	C221	87-010-421-040		CAP,E 4.7-50 5L
CN101	87-A60-996-010		CONN,13P V BLK TAC-L13X-A3	C222	87-010-421-040		CAP,E 4.7-50 5L
CN301	87-A60-620-010		CONN,3P V 2MM JMT	C223	87-010-408-040		CAP,E 47-50 SME
CN351	87-A60-625-010		CONN,8P V 2MM JMT	C224	87-012-369-080		C-CAP,S 0.047-50F
CN601	87-099-719-010		CONN,30P TYK-B(X)	C312	87-010-498-040		CAP,E 10-16 GAS
CN602	87-099-194-010		CONN,6P 6216V	C314	87-010-196-080		CHIP CAPACITOR,0.1-25
CNA1	8A-NF6-646-010		CONN ASSY,9P TID-A(460)	C315	87-010-196-080		CHIP CAPACITOR,0.1-25
CNA2	8A-NF6-630-010		CONN ASSY,3P (VM) ANF-6	C316	87-010-196-080		CHIP CAPACITOR,0.1-25
CNA101	8A-NF6-670-010		CONN ASSY,2P (MUTE) ANF-6	C321	87-012-393-080		C-CAP,S 0.22-16 R K
CON301	87-NF6-615-010		CONN ASSY,3P PB	C382	87-010-320-080		CHIP CAP 68P
CON351	87-NF6-616-010		CONN ASSY,8P RPB	C383	87-010-196-080		CHIP CAPACITOR,0.1-25
FB501	87-008-372-080		FILTER, EMI BL OIRNI	C384	87-010-196-080		CHIP CAPACITOR,0.1-25
FC602	88-906-621-110		FF-CABLE,6P 1.25 620MM	C385	87-010-196-080		CHIP CAPACITOR,0.1-25
FFE831	A8-8ZA-190-030		8ZA-1 FEUNM	C386	87-010-196-080		CHIP CAPACITOR,0.1-25
J102	87-A60-238-010		TERMINAL,SP 4P (MSC)	C387	87-010-196-080		CHIP CAPACITOR,0.1-25
J103	87-A60-929-010		JACK,DIA6.3 BLK ST W/S TAI	C392	87-010-320-080		CHIP CAP 68P
J601	87-A60-885-010		JACK,PIN 6P R/W MSC	C402	87-010-196-080		CHIP CAPACITOR,0.1-25
J831	87-A60-202-010		TERMINAL,ANT 4P MSP-154V-02	C403	87-010-322-080		C-CAP,S 100P-50 CH
L101	87-A50-610-010		COIL,1UH K(MDEC)	C404	87-010-322-080		C-CAP,S 100P-50 CH
L102	87-A50-610-010		COIL,1UH K(MDEC)	C405	87-010-322-080		C-CAP,S 100P-50 CH
L301	87-A50-049-010		COIL,TRAP 85K(COI)	C406	87-010-322-080		C-CAP,S 100P-50 CH
L302	87-A50-049-010		COIL,TRAP 85K(COI)	C407	87-010-322-080		C-CAP,S 100P-50 CH
L351	87-007-342-010		COIL,OSC 85K BIAS	C408	87-010-322-080		C-CAP,S 100P-50 CH
L801	87-A50-540-010		COIL,FM DET(TOK)	C461	87-010-196-080		CHIP CAPACITOR,0.1-25
L802	87-A91-551-010		FLTR,PCFJZH-450 L(TOK)	C462	87-010-196-080		CHIP CAPACITOR,0.1-25
L811	87-005-847-080		COIL,2.2UH(CECS)	C463	87-010-196-080		CHIP CAPACITOR,0.1-25
L821	87-A50-209-010		COIL,1POLE MPX(MIT)	C464	87-010-196-080		CHIP CAPACITOR,0.1-25
L822	87-A50-209-010		COIL,1POLE MPX(MIT)	C465	87-010-196-080		CHIP CAPACITOR,0.1-25
L832	87-005-847-080		COIL,2.2UH(CECS)	C652	87-010-183-080		C-CAP,S 2700P-50 B
L951	8A-NF8-667-010		COIL,AM PACK 4(TOK)	C653	87-010-213-080		C-CAP,S 0.015-50 B
R161	87-A00-441-050		RES,270-1/2W J RP	C701	87-010-406-040		CAP,E 22-50 SME
R162	87-A00-441-050		RES,270-1/2W J RP	C802	87-012-154-080		C-CAP,S 150P-50 CH<EXCEPT 80U>
R163	87-A00-441-050		RES,270-1/2W J RP	C804	87-010-187-080		CAP CHIP S5600P<EXCEPT 80U>
R164	87-A00-441-050		RES,270-1/2W J RP	C805	87-010-196-080		CHIP CAPACITOR,0.1-25<EXCEPT 80U>
R790	87-010-197-080		CAP, CHIP 0.01 DM	C806	87-010-401-040		CAP,E 1-50 SME<EXCEPT 80U>
R991	87-010-322-080		C-CAP,S 100P-50 CH	C807	87-010-196-080		CHIP CAPACITOR,0.1-25<EXCEPT 80U>
R993	87-010-322-080		C-CAP,S 100P-50 CH	C808	87-010-196-080		CHIP CAPACITOR,0.1-25<EXCEPT 80U>
R995	87-010-322-080		C-CAP,S 100P-50 CH	C809	87-012-155-080		C-CAP 180P-50CH<EXCEPT 80U>
SFR351	87-A90-433-080		SFR,50K H NVZ6TLTA	C810	87-010-263-040		CAP,E 100-10<EXCEPT 80U>
SFR352	87-A90-433-080		SFR,50K H NVZ6TLTA	C811	87-010-545-040		CAP,E 0.22-50 SME<EXCEPT 80U>
WH1	87-A90-510-010		HLD, WIRE 2.5-9P	C812	87-010-405-040		CAP,E 10-50<EXCEPT 80U>
X991	87-A70-061-010		VIB,XTAL 4.500MHZ CSA-309	CN101	87-099-720-010		CONN,30P TYK-B(P)
				CN104	87-099-017-010		CONN, 15P 6216 V
				CN301	87-099-195-010		CONN,7P 6216 V
FRONT C.B				CN604	87-099-210-010		CONN,5P 6216 H
C101	87-010-197-080		CAP, CHIP 0.01 DM	CN901	87-A60-161-010		CONN,13P H FE
C102	87-010-322-080		C-CAP,S 100P-50 CH	FB801	87-008-372-080		FILTER, EMI BL OIRNI<EXCEPT 80U>
C103	87-010-312-080		C-CAP,S 15P-50 CH	FC104	88-915-111-110		FF-CABLE,15P 1.25
C104	87-012-157-080		C-CAP,S 330P-50 CH	FC301	88-907-421-110		FF-CABLE,7P 1.25 420MM

REF. NO.	PART NO.	KANRI NO.	DESCRIPTION	REF. NO.	PART NO.	KANRI NO.	DESCRIPTION
FC901	88-913-521-110		FF-CABLE,13P 1.25 520MM	LED455	87-A40-496-040		LED,SLR-342MCT31 GRN
FL201	8A-NF6-601-010		FL,BJ750GNK 13G-35S ANF-6	LED456	87-A40-496-040		LED,SLR-342MCT31 GRN
L101	87-A50-333-010		COIL,OSC 9.43MHZ	S349	87-A91-024-180		SW,TACT KSH0611BT
L801	87-A50-093-010		COIL,CLOCK 5.76MHZ<EXCEPT 80U>	S350	87-A91-024-180		SW,TACT KSH0611BT
LED401	87-017-756-040		LED,SLR-342DCT31 ORN	S351	87-A91-024-180		SW,TACT KSH0611BT
LED402	87-017-756-040		LED,SLR-342DCT31 ORN	S352	87-A91-024-180		SW,TACT KSH0611BT
LED403	87-017-756-040		LED,SLR-342DCT31 ORN	S353	87-A91-024-180		SW,TACT KSH0611BT
LED404	87-017-756-040		LED,SLR-342DCT31 ORN	S354	87-A91-024-180		SW,TACT KSH0611BT
LED405	87-017-756-040		LED,SLR-342DCT31 ORN	S355	87-A91-024-180		SW,TACT KSH0611BT
LED406	87-A40-496-040		LED,SLR-342MCT31 GRN				
LED407	87-A40-496-040		LED,SLR-342MCT31 GRN				
LED408	87-A40-496-040		LED,SLR-342MCT31 GRN	MIC C.B			
LED409	87-A40-496-040		LED,SLR-342MCT31 GRN	C601	87-010-186-080		CAP,CHIP 4700P
LED410	87-A40-496-040		LED,SLR-342MCT31 GRN	C602	87-010-405-040		CAP,E 10-50
LED416	87-A40-809-080		LED,LTL-307KK PGRN	C603	87-010-320-080		CHIP CAP 68P
LED417	87-A40-809-080		LED,LTL-307KK PGRN	C604	87-010-546-040		CAP,E 0.33-50
LED418	87-A40-809-080		LED,LTL-307KK PGRN	C606	87-010-112-040		CAP,E 100-16
LED419	87-A40-809-080		LED,LTL-307KK PGRN	C607	87-010-196-080		CHIP CAPACITOR,0.1-25
LED420	87-A40-809-080		LED,LTL-307KK PGRN	C608	87-010-178-080		CHIP CAP 1000P
LED421	87-A40-809-080		LED,LTL-307KK PGRN	C621	87-010-178-080		CHIP CAP 1000P
LED425	87-017-756-040		LED,SLR-342DCT31 ORN	CN603	87-099-212-010		CONN,5P 6216 V
LED426	87-017-756-040		LED,SLR-342DCT31 ORN	FB601	87-008-372-080		FILTER, EMI BL OIRNI
LED431	87-A40-678-010		LED,SELU1E10CXM BLUE-DEF	FC603	88-905-281-110		FF-CABLE, 5P 1.25 280MM
LED432	87-A40-678-010		LED,SELU1E10CXM BLUE-DEF	J601	87-A61-242-010		JACK,6.3 BLK MONO W/SW V KM
LED433	87-A40-678-010		LED,SELU1E10CXM BLUE-DEF	J602	87-A61-242-010		JACK,6.3 BLK MONO W/SW V KM
LED440	87-A91-665-010		LED,SELU1E10 CXM-SLF55 BLUE				
LED441	87-A91-665-010		LED,SELU1E10 CXM-SLF55 BLUE	VM C.B			
LED499	87-A40-317-080		LED,SLR-342VCT31 RED				
S101	87-A91-591-010		SW,RTRY RE0121PVB25FINA24				
S102	87-A91-664-010		SW,RTRY RE0121PVB30F	AMP 1F C.B			
S301	87-A91-024-180		SW,TACT KSH0611BT	C101	87-010-178-080		CHIP CAP 1000P
S302	87-A91-024-180		SW,TACT KSH0611BT	C102	87-010-178-080		CHIP CAP 1000P
S303	87-A91-024-180		SW,TACT KSH0611BT	C103	87-010-545-080		CAP, ELECT 0.22-50V
S304	87-A91-024-180		SW,TACT KSH0611BT	C104	87-010-545-080		CAP, ELECT 0.22-50V
S305	87-A91-024-180		SW,TACT KSH0611BT	C107	87-016-145-080		CAP, ELECT 10-50 M 105 KME<80U>
S306	87-A91-024-180		SW,TACT KSH0611BT	C107	87-010-405-080		CAP, ELECT 10-50V<EXCEPT 80U>
S310	87-A91-024-180		SW,TACT KSH0611BT	C108	87-016-145-080		CAP, ELECT 10-50 M 105 KME<80U>
S311	87-A91-024-180		SW,TACT KSH0611BT	C108	87-010-405-080		CAP, ELECT 10-50V<EXCEPT 80U>
S312	87-A91-024-180		SW,TACT KSH0611BT	C113	87-010-405-080		CAP, ELECT 10-50V
S313	87-A91-024-180		SW,TACT KSH0611BT	C114	87-010-405-080		CAP, ELECT 10-50V
S314	87-A91-024-180		SW,TACT KSH0611BT<EXCEPT 80U>	C115	87-A12-180-080		CAP, ELECT 10-63 M 105 KME<80U>
S321	87-A91-024-180		SW,TACT KSH0611BT	C115	87-016-299-080		CAP,E 10-100 SME<EXCEPT 80U>
S322	87-A91-024-180		SW,TACT KSH0611BT	C116	87-A12-180-080		CAP, ELECT 10-63 M 105 KME<80U>
S323	87-A91-024-180		SW,TACT KSH0611BT	C116	87-016-299-080		CAP,E 10-100 SME<EXCEPT 80U>
S324	87-A91-024-180		SW,TACT KSH0611BT	C119	87-010-197-080		CAP, CHIP 0.01 DM
S325	87-A91-024-180		SW,TACT KSH0611BT	C120	87-010-197-080		CAP, CHIP 0.01 DM
S326	87-A91-024-180		SW,TACT KSH0611BT	C133	87-010-190-080		C-CAP,S 0.01-50 ZF
S327	87-A91-024-180		SW,TACT KSH0611BT	C153	87-010-188-080		C-CAP,S 6800P-50 B
S328	87-A91-024-180		SW,TACT KSH0611BT	C201	87-A10-300-080		CAP,M 0.027-50 J
S329	87-A91-024-180		SW,TACT KSH0611BT<EXCEPT 80U>	C202	87-A10-300-080		CAP,M 0.027-50 J
S330	87-A91-024-180		SW,TACT KSH0611BT<EXCEPT 80U>	C203	87-A10-300-080		CAP,M 0.027-50 J
S331	87-A91-024-180		SW,TACT KSH0611BT<EXCEPT 80U>	C204	87-A10-300-080		CAP,M 0.027-50 J
S332	87-A91-024-180		SW,TACT KSH0611BT<EXCEPT 80U>	C205	87-010-180-080		C-CER 1500P
S333	87-A91-024-180		SW,TACT KSH0611BT	C206	87-010-180-080		C-CER 1500P
S334	87-A91-024-180		SW,TACT KSH0611BT	C207	87-010-401-080		CAP, ELECT 1-50V
S341	87-A91-024-180		SW,TACT KSH0611BT	C208	87-010-401-080		CAP, ELECT 1-50V
S342	87-A91-024-180		SW,TACT KSH0611BT	C209	87-010-187-080		CAP CHIP S5600P
S343	87-A91-024-180		SW,TACT KSH0611BT	C210	87-010-187-080		CAP CHIP S5600P
S344	87-A91-024-180		SW,TACT KSH0611BT	C211	87-016-142-080		CAP, ELECT 2.2-50 KME<80U>
S345	87-A91-024-180		SW,TACT KSH0611BT	C211	87-010-402-080		CAP, ELECT 2.2-50V<EXCEPT 80U>
S346	87-A91-024-180		SW,TACT KSH0611BT	C212	87-010-402-080		CAP, ELECT 2.2-50V
S347	87-A91-024-180		SW,TACT KSH0611BT	C215	87-012-140-080		C-CAP,S 470P-50 J CH
CD KEY C.B				C216	87-012-140-080		C-CAP,S 470P-50 J CH
CN302	87-099-195-010		CONN,7P 6216 V	C217	87-010-401-080		CAP, ELECT 1-50V
LED451	87-017-756-040		LED,SLR-342DCT31 ORN	C218	87-016-141-080		CAP, ELECT 1-50 M 105 KME<80U>
LED452	87-017-756-040		LED,SLR-342DCT31 ORN	C218	87-010-401-080		CAP, ELECT 1-50V<EXCEPT 80U>
LED453	87-017-756-040		LED,SLR-342DCT31 ORN	C221	87-010-405-080		CAP, ELECT 10-50V
LED454	87-A40-496-040		LED,SLR-342MCT31 GRN	C222	87-010-405-080		CAP, ELECT 10-50V
				C223	87-010-197-080		CAP, CHIP 0.01 DM
				C224	87-010-197-080		CAP, CHIP 0.01 DM

REF. NO.	PART NO.	KANRI NO.	DESCRIPTION	REF. NO.	PART NO.	KANRI NO.	DESCRIPTION
C251	87-012-368-080		C-CAP,S 0.1-50 F	C324	87-010-196-080		CHIP CAPACITOR,0.1-25
C252	87-012-368-080		C-CAP,S 0.1-50 F	C325	87-010-186-080		CAP,CHIP 4700P
C253	87-010-196-080		CHIP CAPACITOR,0.1-25	C401	87-010-196-080		CHIP CAPACITOR,0.1-25
C254	87-010-196-080		CHIP CAPACITOR,0.1-25	C402	87-010-196-080		CHIP CAPACITOR,0.1-25
C401	87-010-260-080		CAP, ELECT 47-25V	C403	87-010-405-080		CAP, ELECT 10-50V
CNN101	87-A61-011-010		CONN,13P H BLK TAC-L13P-A3	C404	87-010-405-080		CAP, ELECT 10-50V
CNN102	87-A61-011-010		CONN,13P H BLK TAC-L13P-A3	CNN101	87-099-195-010		CONN,7P 6216 V
CNN106	87-099-195-010		CONN,7P 6216 V	CNN102	87-049-919-010		CONN,3P EH V WHT
CNA101	8A-NF6-645-010		CONN ASSY,5P TID-A(530)	CNN103	87-A60-619-010		CONN,2P V 2MM JMT
CNA102	8A-NF6-660-010		CONN ASSY,3P (SATE) ANF-6	J301	87-A61-189-010		JACK,3.5 MONO
FC106	88-907-151-110		FF-CABLE, 7P 1.25 150MM	J302	87-A61-189-010		JACK,3.5 MONO
J201	87-A61-148-010		JACK,PIN 4P R/W BLUE	L301	87-003-383-010		COIL,1UH-S
L251	87-003-383-010		COIL,1UH-S	L302	87-003-383-010		COIL,1UH-S
L252	87-003-383-010		COIL,1UH-S				
R129	87-A00-262-080		RES,M/F 0.15-2W J				
				PT C.B			
R130	87-A00-262-080		RES,M/F 0.15-2W J	C1	87-010-387-080		CAP,E 470-25 SME
R231	87-A00-258-080		RES,M/F 0.22-1W J	C4	87-A11-148-080		CAP,TC U 0.1-50 Z F
R232	87-A00-258-080		RES,M/F 0.22-1W J	C5	87-A11-148-080		CAP,TC U 0.1-50 Z F
WH101	87-A90-459-010		HLDR,WIRE 2.5-5P	C6	87-010-917-000		CAP,E 3300-50 M SMG
				C7	87-010-917-000		CAP,E 3300-50 M SMG
AMP SATE C.B							
C201	87-010-263-080		CAP, ELECT 100-10V	C8	87-A11-148-080		CAP,TC U 0.1-50 Z F
C211	87-012-393-080		C-CAP,S 0.22-16 R K	C9	87-A11-148-080		CAP,TC U 0.1-50 Z F
C212	87-012-393-080		C-CAP,S 0.22-16 R K	C10	87-A11-148-080		CAP,TC U 0.1-50 Z F
C213	87-012-393-080		C-CAP,S 0.22-16 R K	C11	87-A11-148-080		CAP,TC U 0.1-50 Z F
C214	87-012-393-080		C-CAP,S 0.22-16 R K	C12	87-016-520-000		CAP,E 3300-65 M SMG<80U>
				C12	87-016-657-090		CAP,E 3300-71<EXCEPT 80U>
C215	87-010-196-080		CHIP CAPACITOR,0.1-25	C13	87-016-520-000		CAP,E 3300-65 M SMG<80U>
C216	87-010-196-080		CHIP CAPACITOR,0.1-25	C13	87-016-657-090		CAP,E 3300-71<EXCEPT 80U>
C217	87-012-141-080		CHIP-CAPACITOR,0.22-16F	C16	87-010-403-080		CAP, ELECT 3.3-50V
C218	87-012-141-080		CHIP-CAPACITOR,0.22-16F	CN1	87-A61-110-010		CONN,9P V TID-A
C219	87-010-184-080		CHIP CAPACITOR 3300P(K)				
				△ CN2	87-A61-108-010		CONN,5P V TID-A
C220	87-010-184-080		CHIP CAPACITOR 3300P(K)	△ PT2	8A-NF8-673-010		PT,SUB ANF-8 (H)KAMI<EXCEPT 80U>
C221	87-010-177-080		C-CAP,S 820P-50 SL	△ PT2	8A-NF8-661-010		PT,SUB ANF-8 (U)<80U>
C222	87-010-177-080		C-CAP,S 820P-50 SL	△ PT101	8A-NF6-622-010		PT,LH EI96-60 ANF-6<EXCEPT 80U>
C223	87-016-669-080		C-CAP,S 0.1-25 K B	△ PT101	8A-NF6-621-010		PT,U EI96-60 ANF-6<80U>
C224	87-016-669-080		C-CAP,S 0.1-25 K B				
				△ RY1	87-A91-281-010		RELAY,ACDC12V OSA-SS-212DM5<EX 80U>
C225	87-016-669-080		C-CAP,S 0.1-25 K B	△ RY2	87-A90-976-010		RELAY,AC12V SDT-S-112LMR<80U>
C226	87-016-669-080		C-CAP,S 0.1-25 K B	△ S1	87-A90-165-010		SW,SL 1-2-3 SWS2301<EXCEPT 80U>
C227	87-010-184-080		CHIP CAPACITOR 3300P(K)	△ T1	87-A60-317-010		TERMINAL, 1P MSC
C228	87-010-184-080		CHIP CAPACITOR 3300P(K)	△ T2	87-A60-317-010		TERMINAL, 1P MSC
C229	87-010-177-080		C-CAP,S 820P-50 SL				
				DECK C.B			
C230	87-010-177-080		C-CAP,S 820P-50 SL	CON501	87-099-756-019		CONN,15P 9604S F
C231	87-012-141-080		CHIP-CAPACITOR,0.22-16F	SFR1	87-024-581-010		SFR,3.3K DIA 6H
C232	87-012-141-080		CHIP-CAPACITOR,0.22-16F	SOL1	82-ZM1-618-410		SOL ASSY,27
C233	87-010-374-080		CAP, ELECT 47-10V	SOL2	82-ZM1-618-410		SOL ASSY,27
C234	87-010-374-080		CAP, ELECT 47-10V	SW1	87-A90-248-010		SW,MICRO ESE11SH2CXQ
C235	87-010-544-080		CAP, ELECT 0.1-50V	SW2	87-A90-248-010		SW,MICRO ESE11SH2CXQ
C236	87-010-544-080		CAP, ELECT 0.1-50V	SW3	87-A90-248-010		SW,MICRO ESE11SH2CXQ
C237	87-010-183-080		C-CAP,S 2700P-50 B	SW4	87-036-110-010		SW,MICRO SPPB62
C238	87-010-183-080		C-CAP,S 2700P-50 B	SW5	87-036-110-010		SW,MICRO SPPB62
C239	87-010-544-080		CAP, ELECT 0.1-50V	SW6	87-036-110-010		SW,MICRO SPPB62
C240	87-010-544-080		CAP, ELECT 0.1-50V	SW8	87-A90-248-010		SW,MICRO ESE11SH2CXQ
C301	87-010-178-080		CHIP CAP 1000P	SW9	87-A90-248-010		SW,MICRO ESE11SH2CXQ
C302	87-010-178-080		CHIP CAP 1000P	W1	82-ZM3-601-010		RBN-CORD,4P-75
C303	87-010-544-080		CAP, ELECT 0.1-50V				
C304	87-010-544-080		CAP, ELECT 0.1-50V				
				HEAD-1 C.B			
C309	87-010-401-080		CAP, ELECT 1-50V				
C310	87-010-401-080		CAP, ELECT 1-50V				
C311	87-010-260-080		CAP, ELECT 47-25V				
C312	87-010-260-080		CAP, ELECT 47-25V				
C315	87-A10-596-080		C-CAP,S 100P-100 J CH	HEAD-2 C.B			
C316	87-A10-596-080		C-CAP,S 100P-100 J CH				
C317	87-010-197-080		CAP, CHIP 0.01 DM				
C318	87-010-197-080		CAP, CHIP 0.01 DM				
C319	87-012-368-080		C-CAP,S 0.1-50 F				
C320	87-012-368-080		C-CAP,S 0.1-50 F				
C321	87-010-197-080		CAP, CHIP 0.01 DM				
C322	87-010-197-080		CAP, CHIP 0.01 DM				
C323	87-010-196-080		CHIP CAPACITOR,0.1-25				

TRANSISTOR ILLUSTRATION



E C B

KTA1266GR
KTC3198GR
CD1585BC
CSA952K



E C B

CC5551



E C B

CSC4115BC



B C E

2SB1370
2SB1370F
2SD2061F

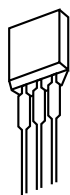

E C B

DTC114ES
KTC3199GR
2SA933S

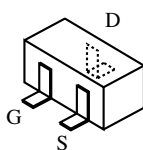

2SK2158
2SJ461-T1

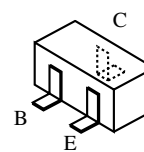

2SA1235F
2SC2714O
2SC3052F
CMBT5551
CMBT5401

RT1P141C
CSD1306E
KRA104S
KRC102S-RTK
KRA107S

○チップ抵抗部品コード／CHIP RESISTOR PART CODE

チップ抵抗部品コードの成り立ち

Chip Resistor Part Coding



A
抵抗部品コード
Resistor Code

桁表示
Figure
抵抗値
Value of resistor

チップ抵抗 Chip resistor

容量 Wattage	種類 Type	許容誤差 Tolerance	記号 Symbol	寸法／Dimensions (mm)			抵抗コード : A Resistor Code : A	
				外形／Form	L	W		t
1/16W	1005	± 5%	CJ		1.0	0.5	0.35	104
1/16W	1608	± 5%	CJ		1.6	0.8	0.45	108
1/10W	2125	± 5%	CJ		2	1.25	0.45	118
1/8W	3216	± 5%	CJ		3.2	1.6	0.55	128

A MAIN C.B

FROM HEAD-2 C.B
CON351
1 5 9 7 8
TO CN351

FROM HEAD-1 C.B
CON301
1 2 3
TO CN301

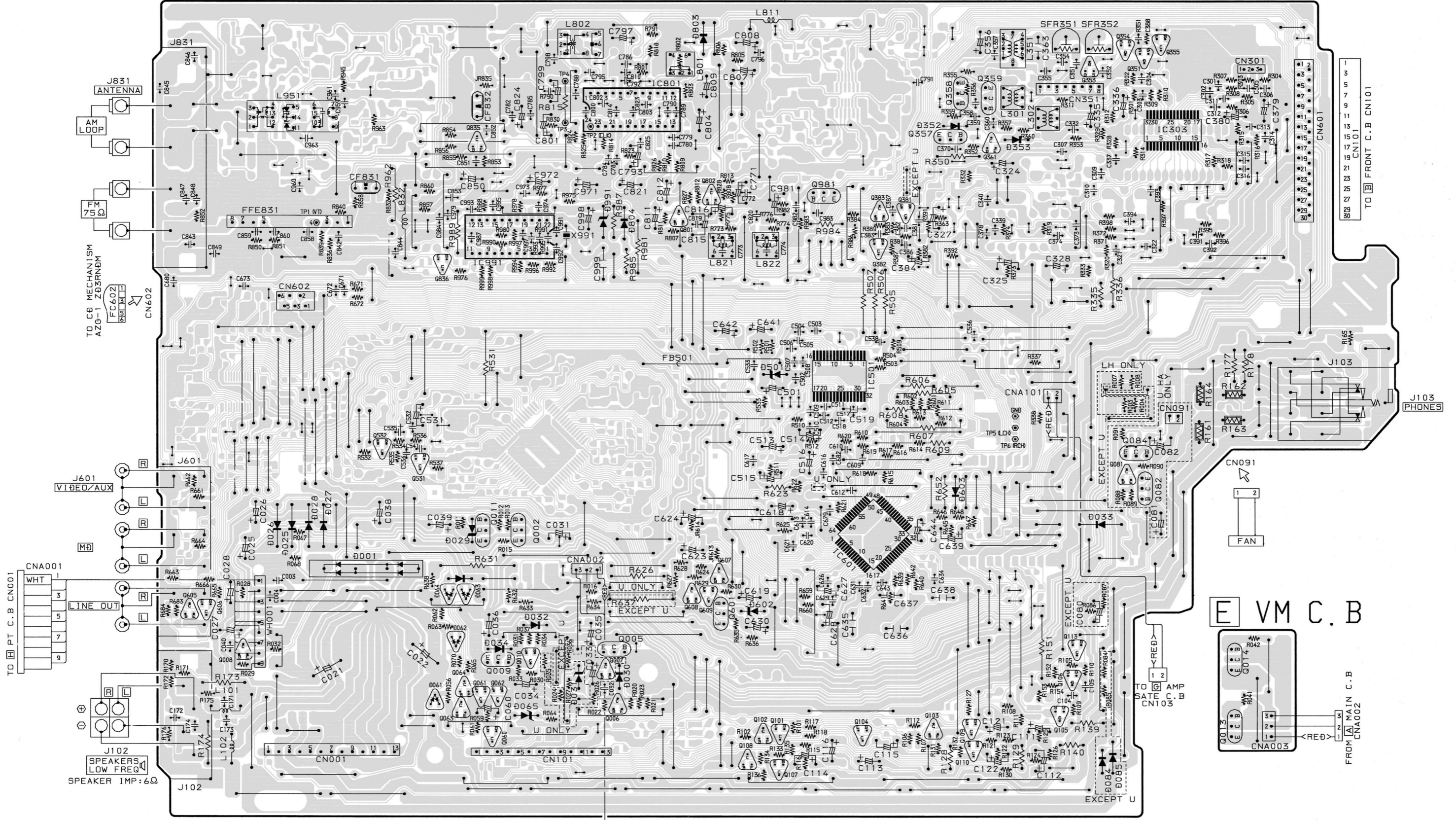

E VM C.B

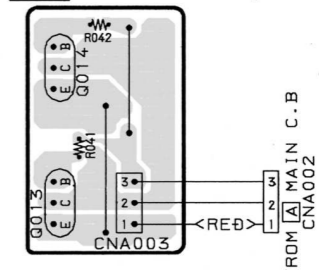

FROM AMP 1F C.B CN102
1 3 5 7 9 11 13
CN102

FROM AMP 1F C.B CN101
1 3 5 7 9 11 13
CN101

TO VM C.B CNA003
1 2 3

A
B
C
D
E
F
G
H
I
J
K
L
M
N
O
P
Q
R
S
T
U

SCHEMATIC DIAGRAM - 1 (MAIN 1/3: AMP SECTION / VM)

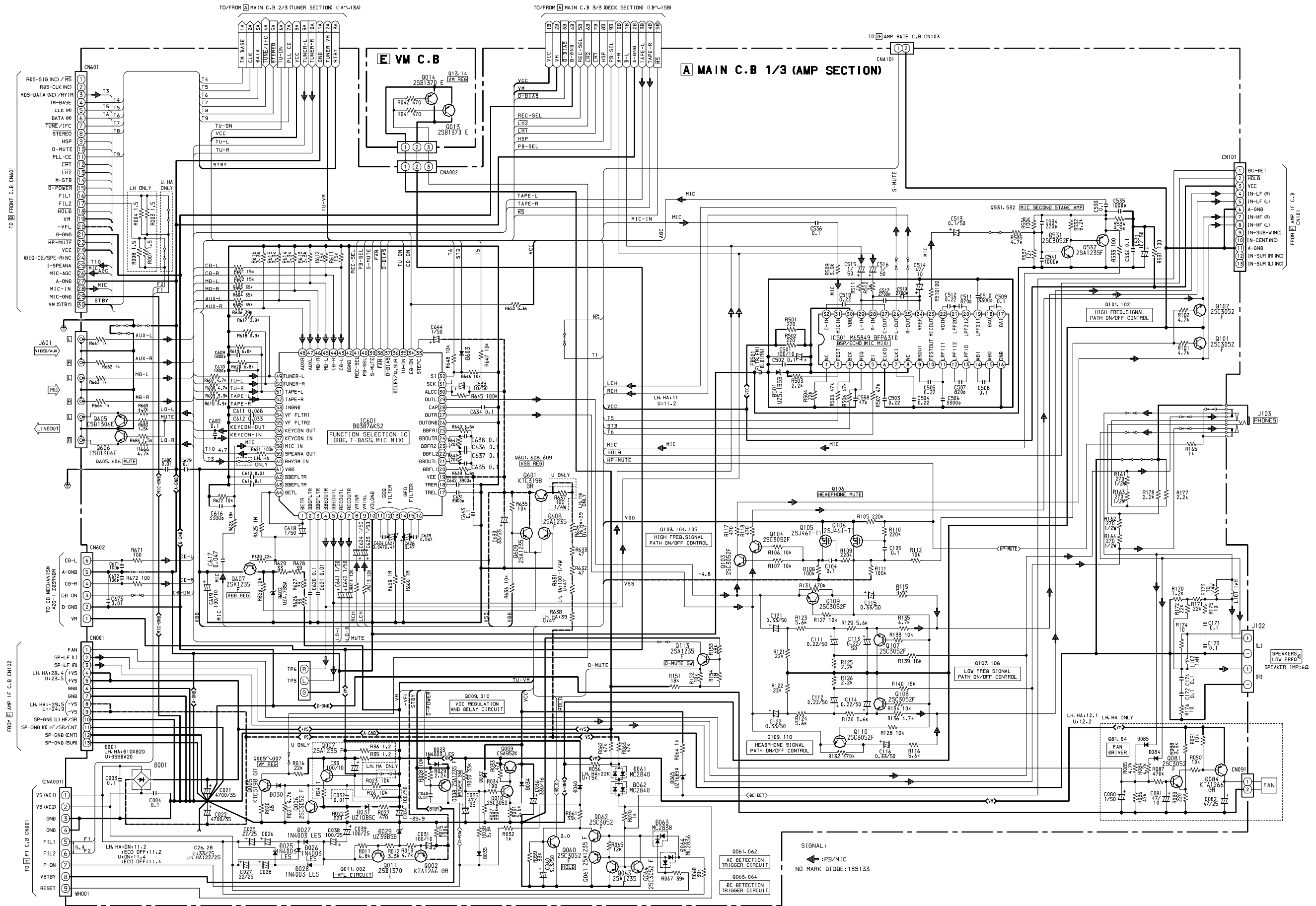

32 31 30 29 28 27 26 25 24 23 22 21 20 19 18 17 16 15 14 13 12 11 10 9 8 7 6 5 4 3 2 1

A
B
C
D
E
F
G
H
I
J
K
L
M
N
O
P
Q
R
S
T
U

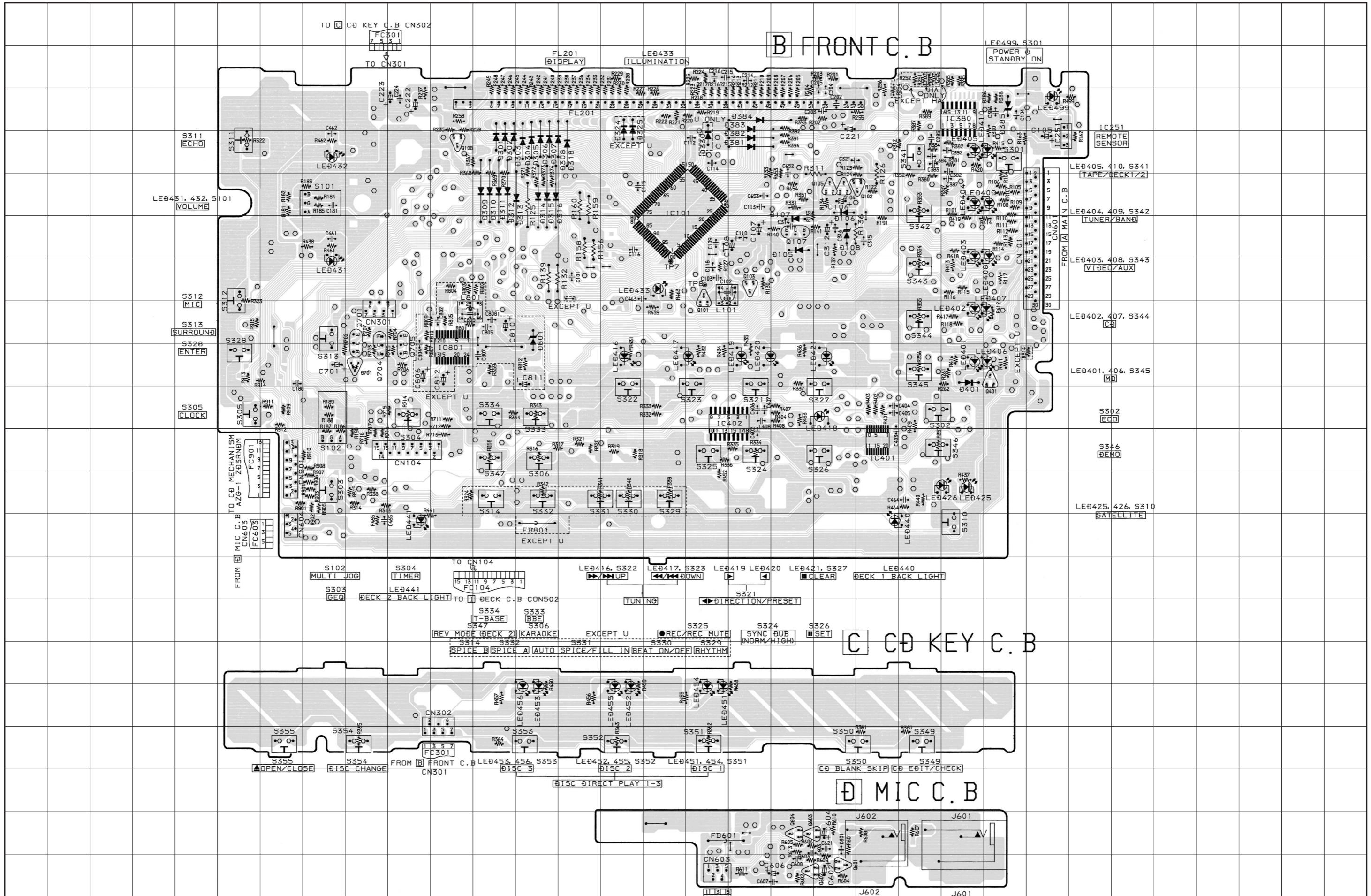

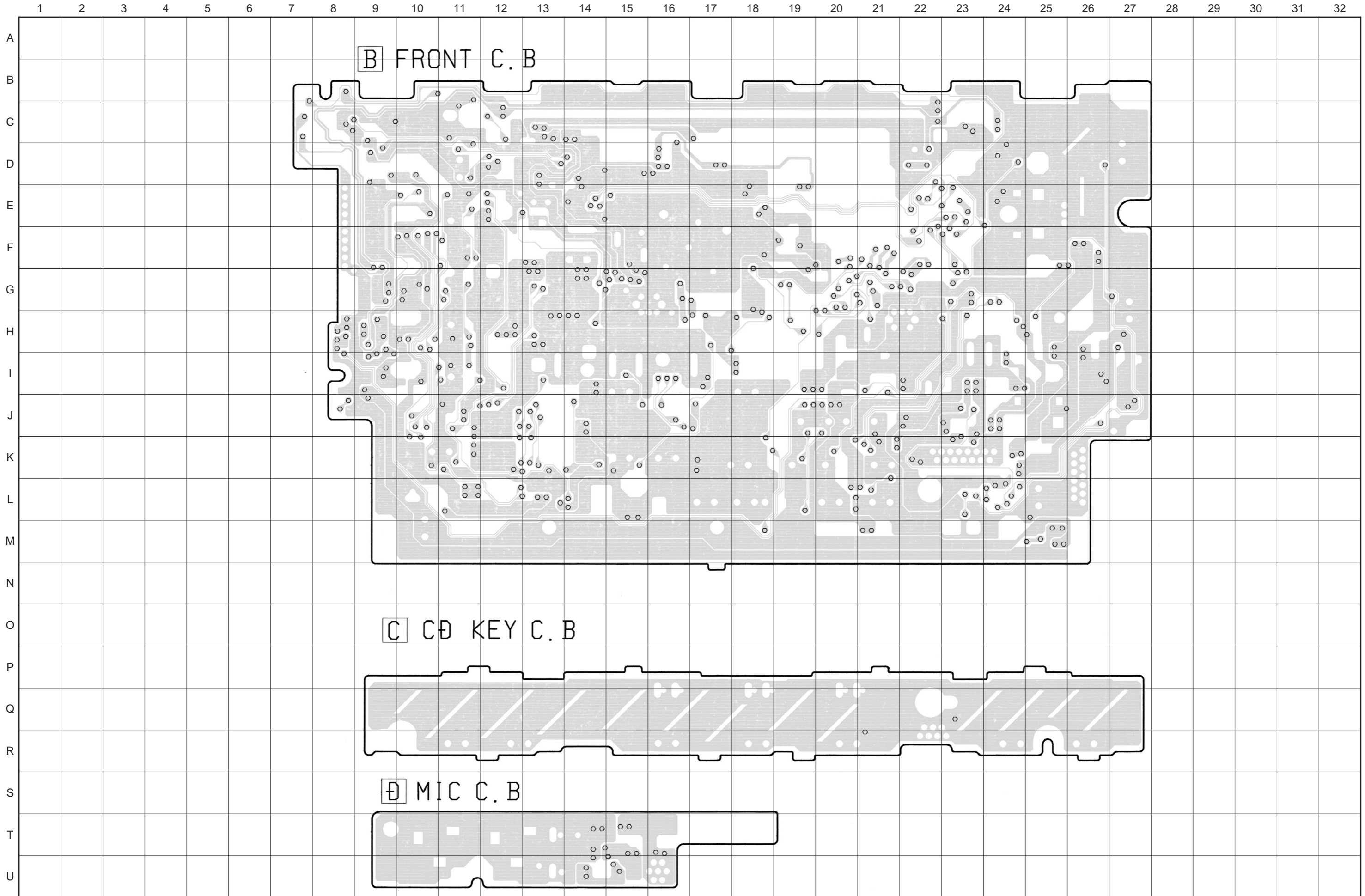

SCHEMATIC DIAGRAM – 4 (FRONT / CD KEY / MIC)

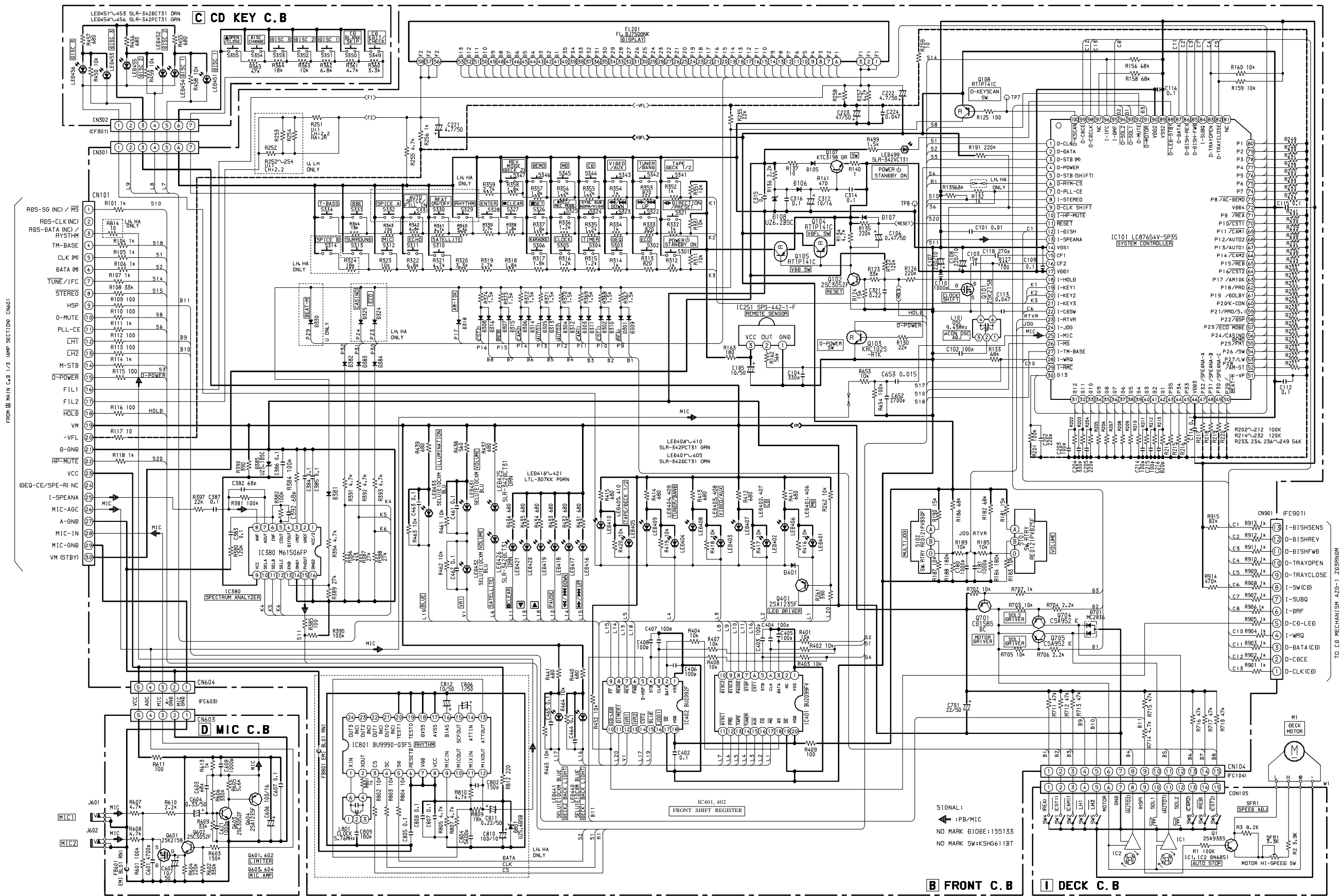

SIGNAL:
 ◀ PB/MIC
 NO MARK 010E:15S133
 NO MARK SW:K5HG611BT

B FRONT C. B

I DECK C. B

32	31	30	29	28	27	26	25	24	23	22	21	20	19	18	17	16	15	14	13	12	11	10	9	8	7	6	5	4	3	2	1
----	----	----	----	----	----	----	----	----	----	----	----	----	----	----	----	----	----	----	----	----	----	----	---	---	---	---	---	---	---	---	---

A
B
C
D
E
F
G
H
I
J
K
L
M
N
O
P
Q
R
S
T
U

F AMP 1F C.B

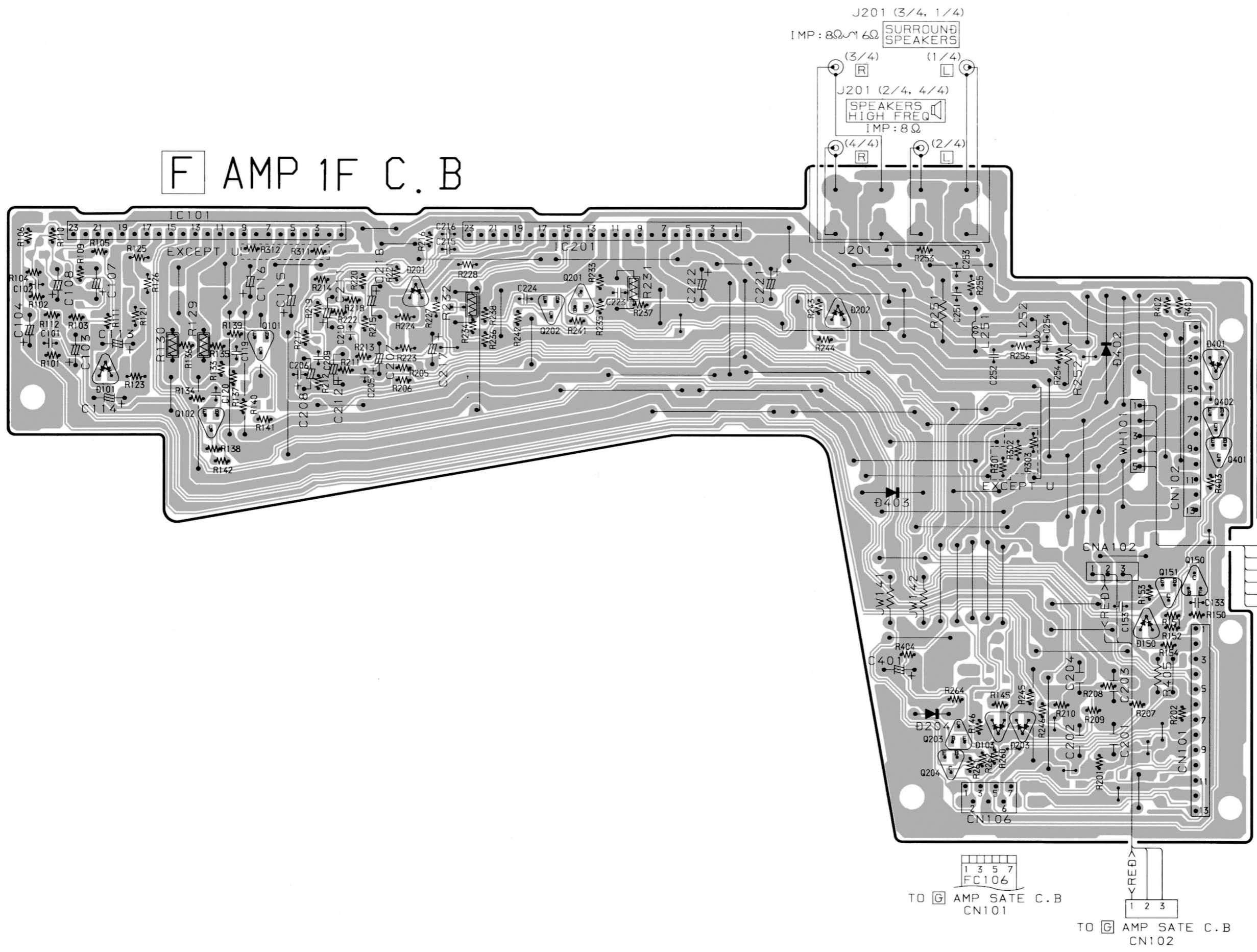

TO G AMP SATE C.B
CN101

TO G AMP SATE C.B
CN102

TO A MAIN C.B CN101

TO A MAIN C.B CN102

TO H PT C.B CN002

G AMP SATE C.B

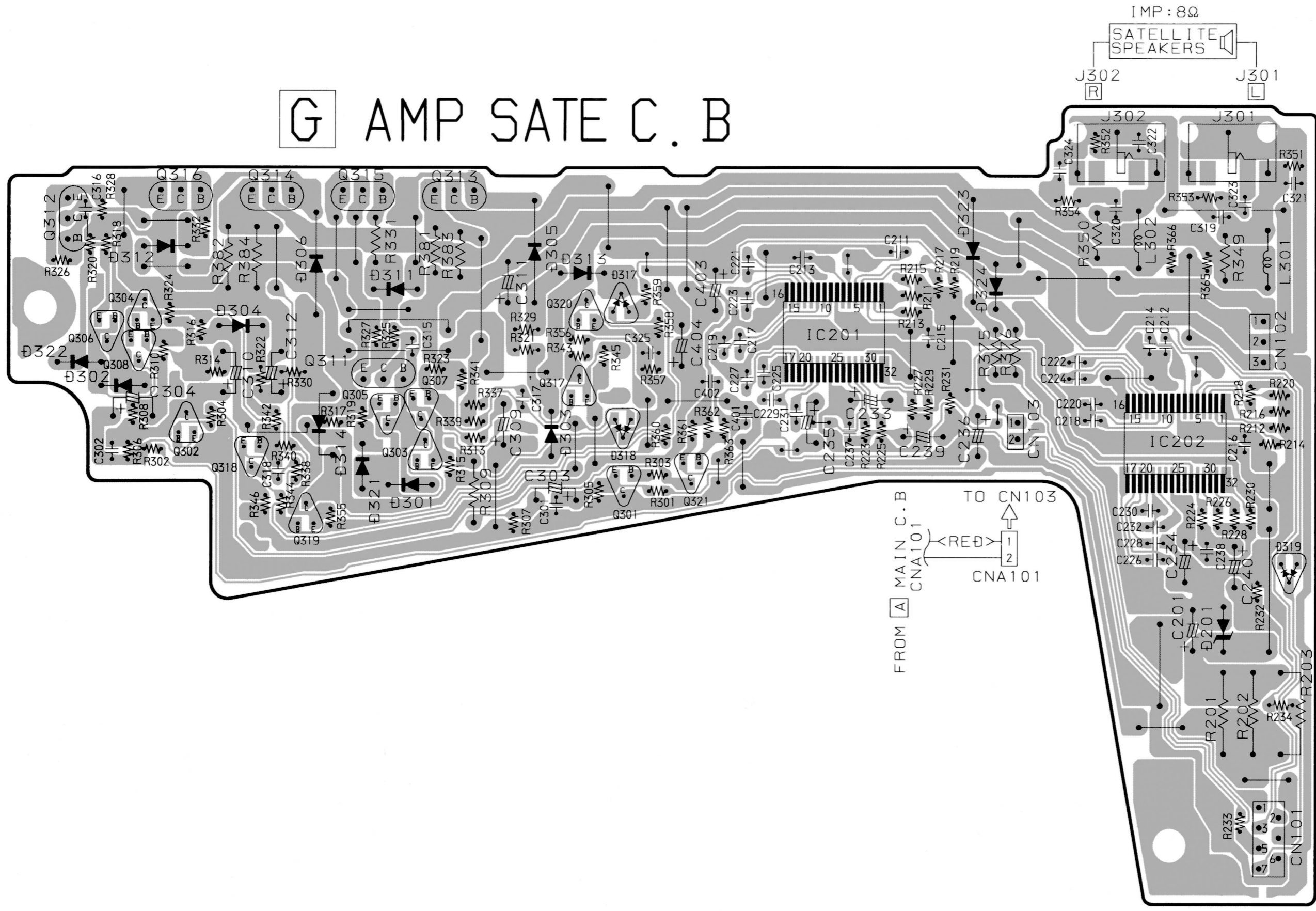

IMP : 8Ω
SATELLITE SPEAKERS

FROM [A] MAIN C.B.
CNA101
TO CN103
CNA101

CNA102
FROM [E] AMP 1F C.B.
CNA102

FROM [F] AMP 1F C.B.
CN106

32	31	30	29	28	27	26	25	24	23	22	21	20	19	18	17	16	15	14	13	12	11	10	9	8	7	6	5	4	3	2	1
----	----	----	----	----	----	----	----	----	----	----	----	----	----	----	----	----	----	----	----	----	----	----	---	---	---	---	---	---	---	---	---

FROM [A] MAIN C.B WH001

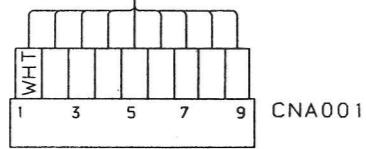

[H] PT C.B
<U>

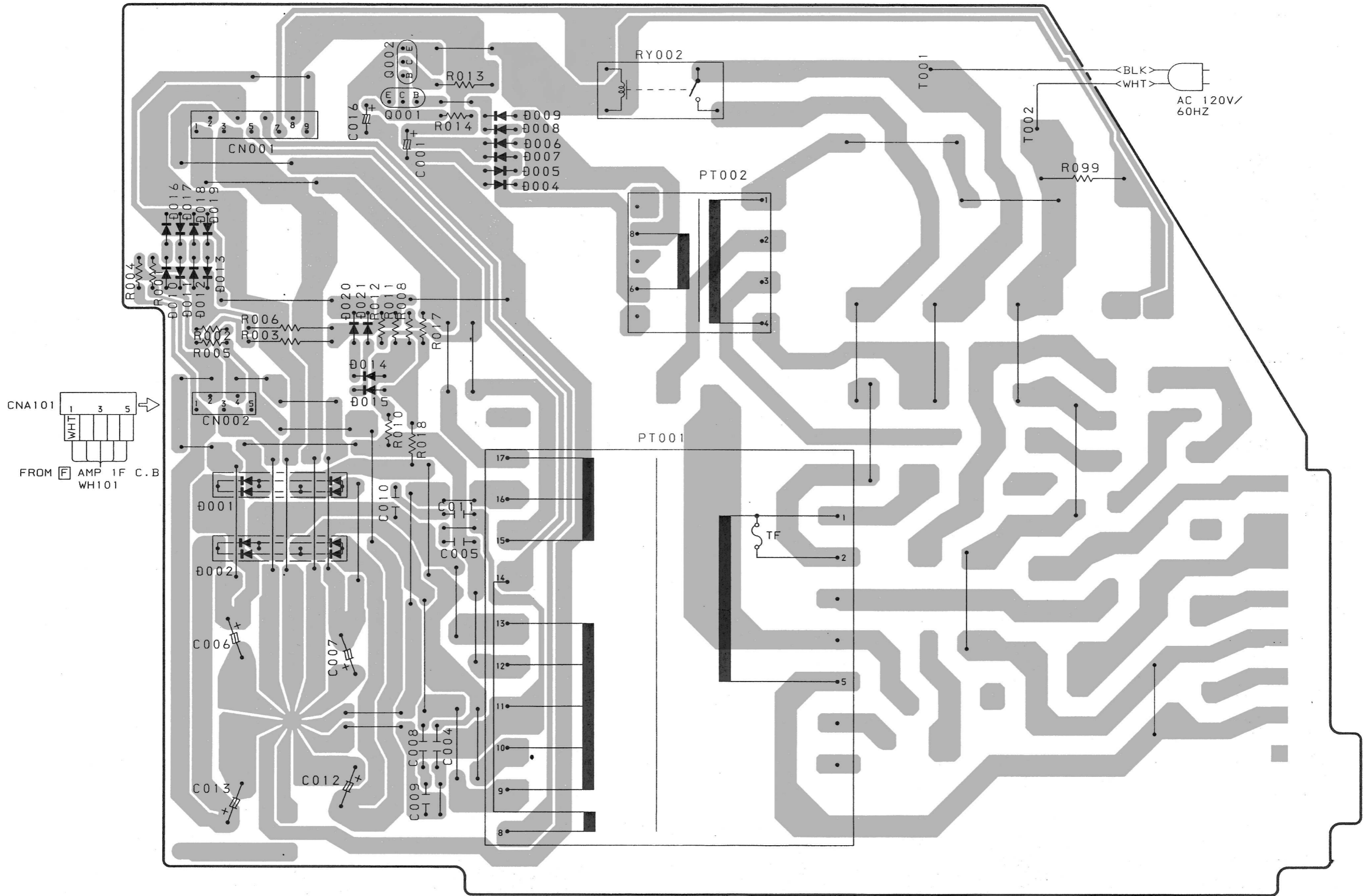

A
B
C
D
E
F
G
H
I
J
K
L
M
N
O
P
Q
R
S
T
U

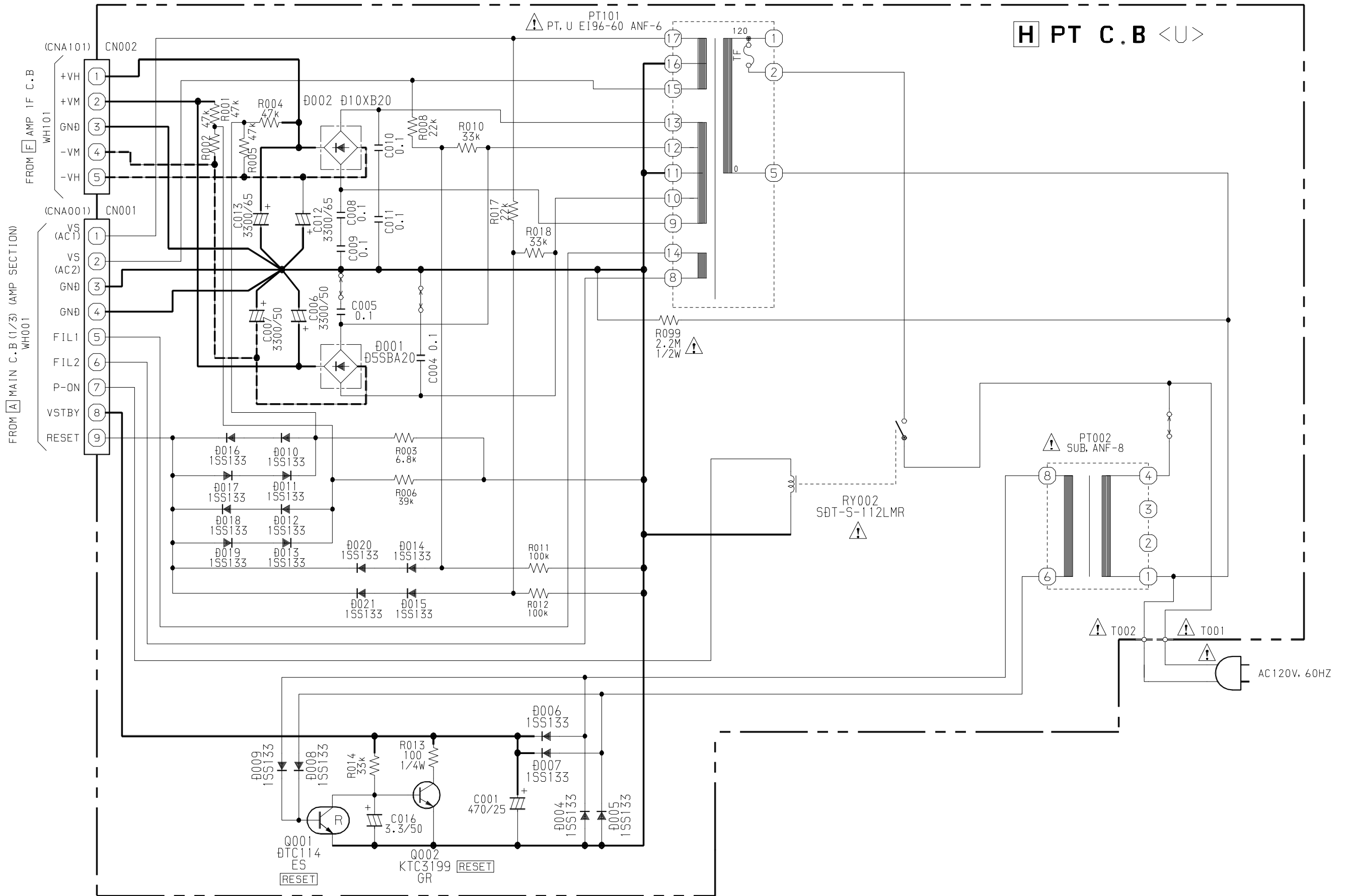

FROM [A] MAIN C.B WH001

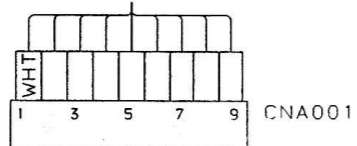

H PT C.B
<EXCEPT U>

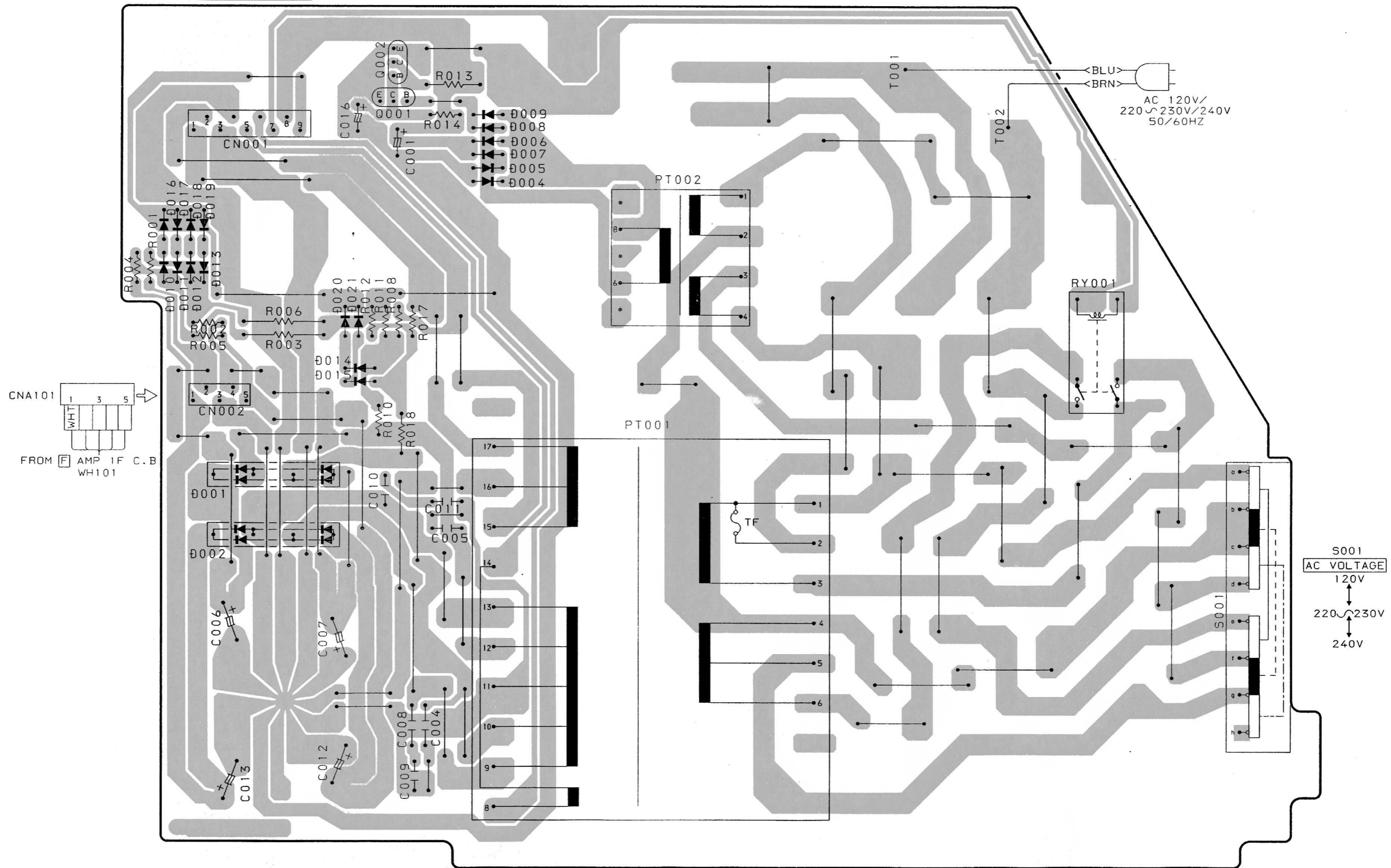

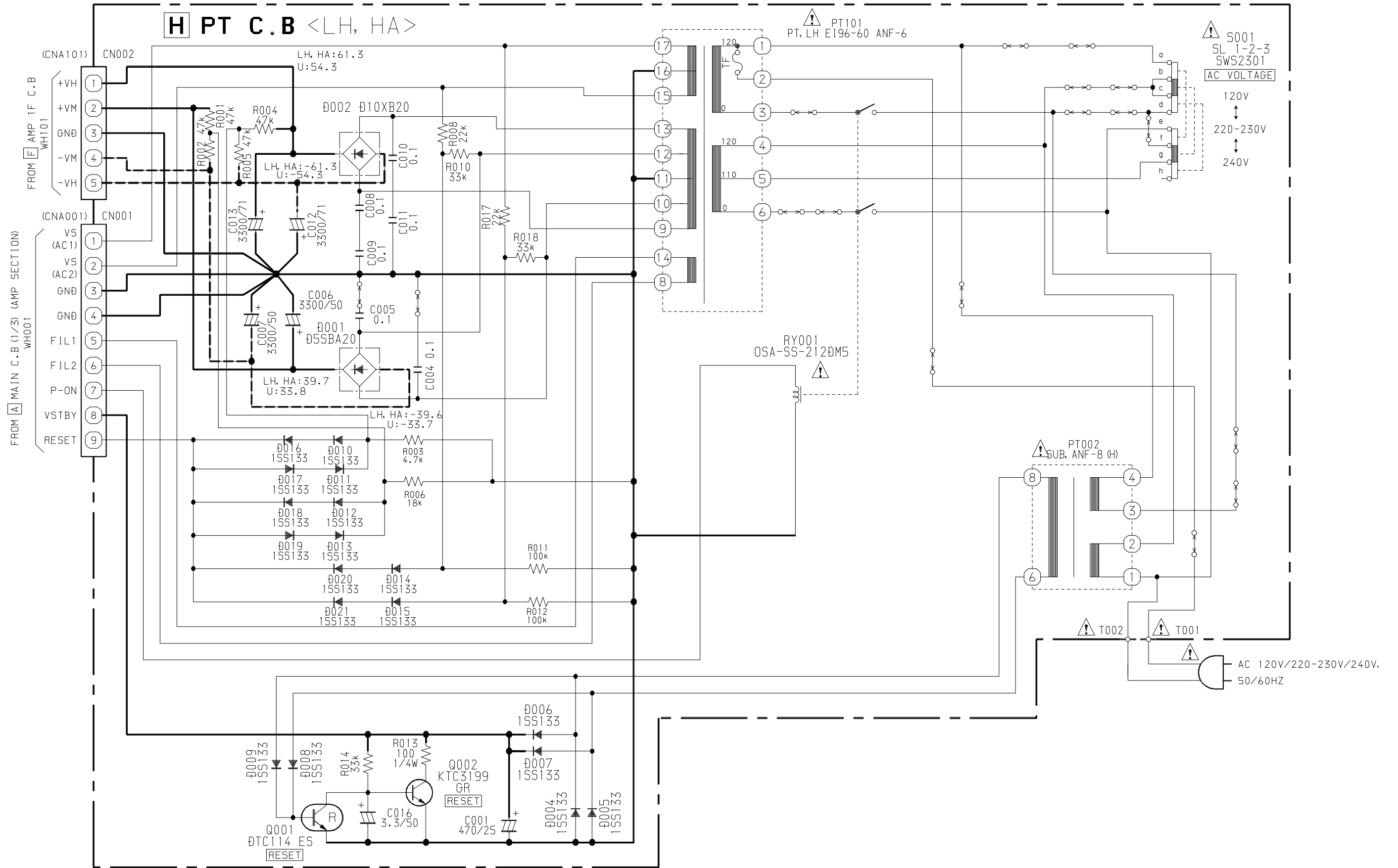

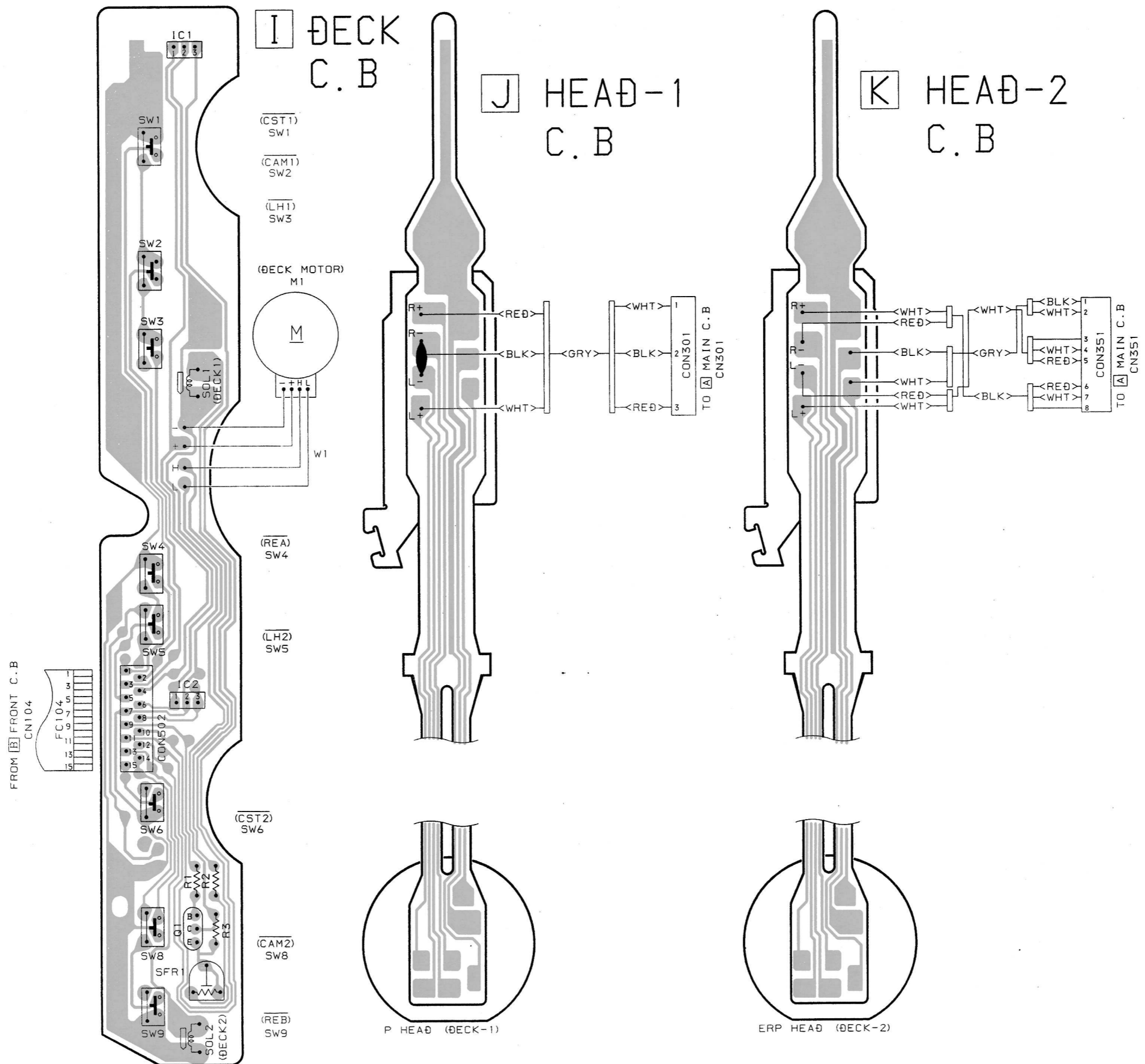

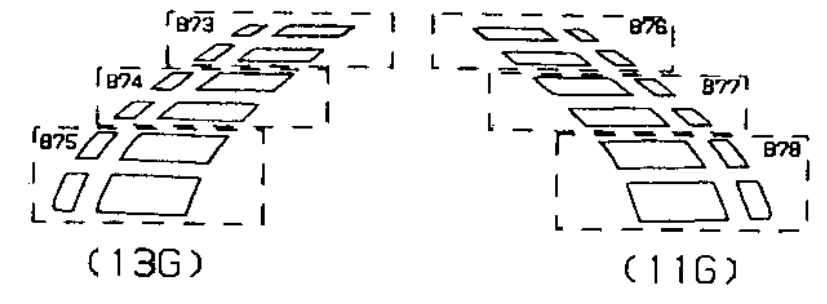
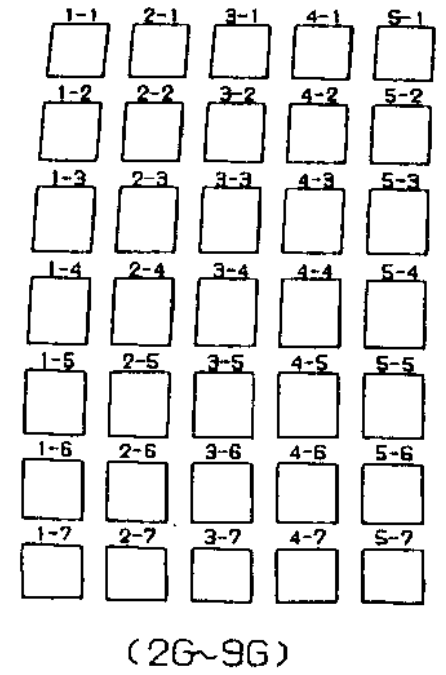
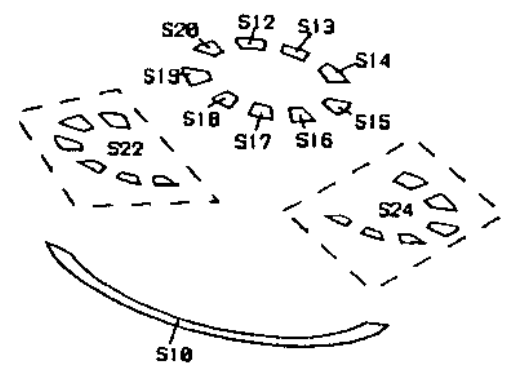
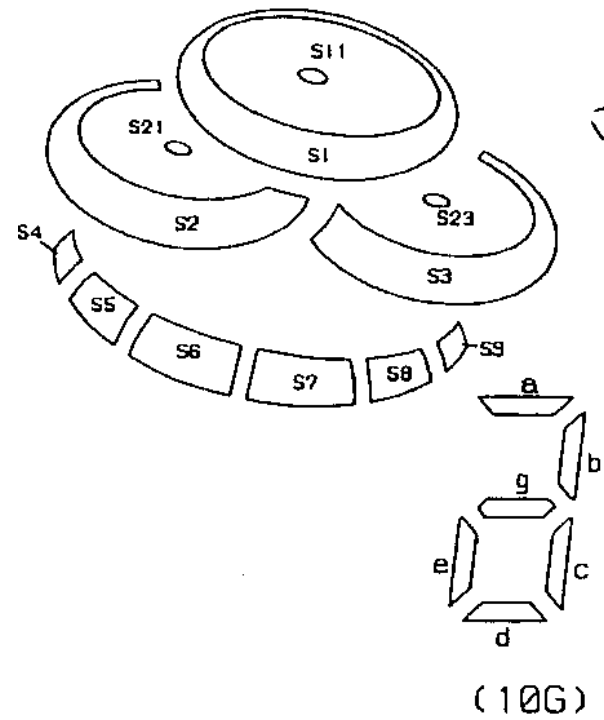
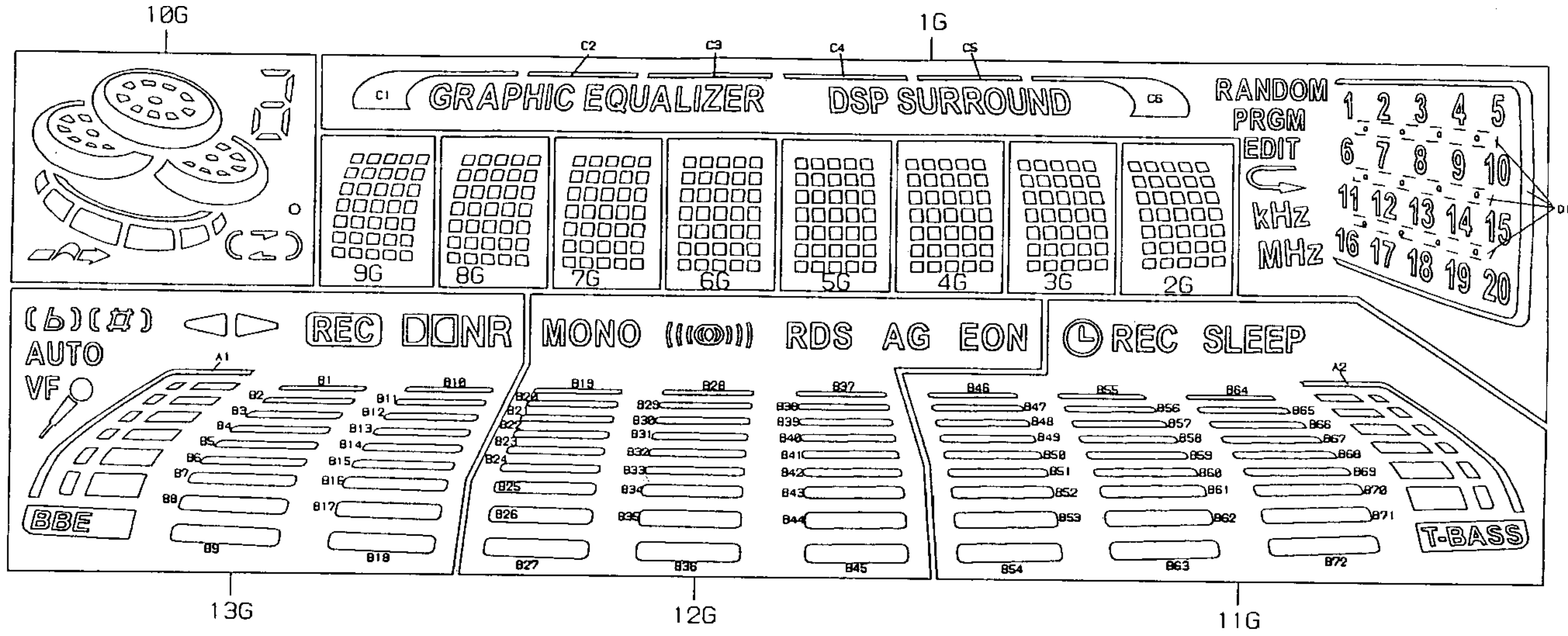

ANODE CONNECTION

	13G	12G	11G	10G	9G	8G	7G	6G	5G	4G	3G	2G	1G
P1		B27	B54	b	1-1	1-1	1-1	1-1	1-1	1-1	1-1	1-1	DEP SURROUND
P2		B36	B63	c	2-1	2-1	2-1	2-1	2-1	2-1	2-1	2-1	GRAPHIC EQUALIZER
P3		B45	B72	a, d, g	3-1	3-1	3-1	3-1	3-1	3-1	3-1	3-1	C6
P4		B26	B53	e	4-1	4-1	4-1	4-1	4-1	4-1	4-1	4-1	C5
P5		B35	B62	S1	5-1	5-1	5-1	5-1	5-1	5-1	5-1	5-1	C4
P6		B44	B71	S12	1-2	1-2	1-2	1-2	1-2	1-2	1-2	1-2	C3
P7		B25	B52	S13	2-2	2-2	2-2	2-2	2-2	2-2	2-2	2-2	C2
P8		B34	B61	S20	3-2	3-2	3-2	3-2	3-2	3-2	3-2	3-2	C1
P9		B43	B70	S14	4-2	4-2	4-2	4-2	4-2	4-2	4-2	4-2	RANDOM
P10	A1	B24	B51	S11	5-2	5-2	5-2	5-2	5-2	5-2	5-2	5-2	PRGM
P11		B33	B60	S19	1-3	1-3	1-3	1-3	1-3	1-3	1-3	1-3	EDIT
P12	B75	B42	B69	S15	2-3	2-3	2-3	2-3	2-3	2-3	2-3	2-3	
P13	B74	B23	B50	S18	3-3	3-3	3-3	3-3	3-3	3-3	3-3	3-3	KHz
P14	B73	B32	B59	S16	4-3	4-3	4-3	4-3	4-3	4-3	4-3	4-3	MHz
P15	B9	B41	B68	S17	5-3	5-3	5-3	5-3	5-3	5-3	5-3	5-3	16
P16	B18	B22	B49	S3	1-4	1-4	1-4	1-4	1-4	1-4	1-4	1-4	11
P17	B8	B31	B58	S24	2-4	2-4	2-4	2-4	2-4	2-4	2-4	2-4	6
P18	B17	B40	B67	S23	3-4	3-4	3-4	3-4	3-4	3-4	3-4	3-4	1
P19	B7	B21	B48	S2	4-4	4-4	4-4	4-4	4-4	4-4	4-4	4-4	17
P20	B16	B30	B57	S22	5-4	5-4	5-4	5-4	5-4	5-4	5-4	5-4	12
P21	B6	B39	B66	S21	1-5	1-5	1-5	1-5	1-5	1-5	1-5	1-5	7
P22	B15	B20	B47	S10	2-5	2-5	2-5	2-5	2-5	2-5	2-5	2-5	2
P23	B5	B29	B56	S9	3-5	3-5	3-5	3-5	3-5	3-5	3-5	3-5	18
P24	B14	B38	B65	S8	4-5	4-5	4-5	4-5	4-5	4-5	4-5	4-5	13
P25	B4	B19	B46	S7	5-5	5-5	5-5	5-5	5-5	5-5	5-5	5-5	8
P26	B13	B28	B55	S6	1-6	1-6	1-6	1-6	1-6	1-6	1-6	1-6	3
P27	B3	B37	B64	S5	2-6	2-6	2-6	2-6	2-6	2-6	2-6	2-6	19
P28	B12	MONO	TRASS	S4	3-6	3-6	3-6	3-6	3-6	3-6	3-6	3-6	14
P29	B2		A2		4-6	4-6	4-6	4-6	4-6	4-6	4-6	4-6	9
P30	B11	RDS	B78		5-6	5-6	5-6	5-6	5-6	5-6	5-6	5-6	4
P31	B1	AG	B77		1-7	1-7	1-7	1-7	1-7	1-7	1-7	1-7	20
P32	B10	EON	B76		2-7	2-7	2-7	2-7	2-7	2-7	2-7	2-7	15
P33	-	-	SLEEP		3-7	3-7	3-7	3-7	3-7	3-7	3-7	3-7	10
P34	-	-	REC	-	4-7	4-7	4-7	4-7	4-7	4-7	4-7	4-7	5
P35	-	-		-	5-7	5-7	5-7	5-7	5-7	5-7	5-7	5-7	D1

IC BLOCK DIAGRAM

IC, M65849BFP631D

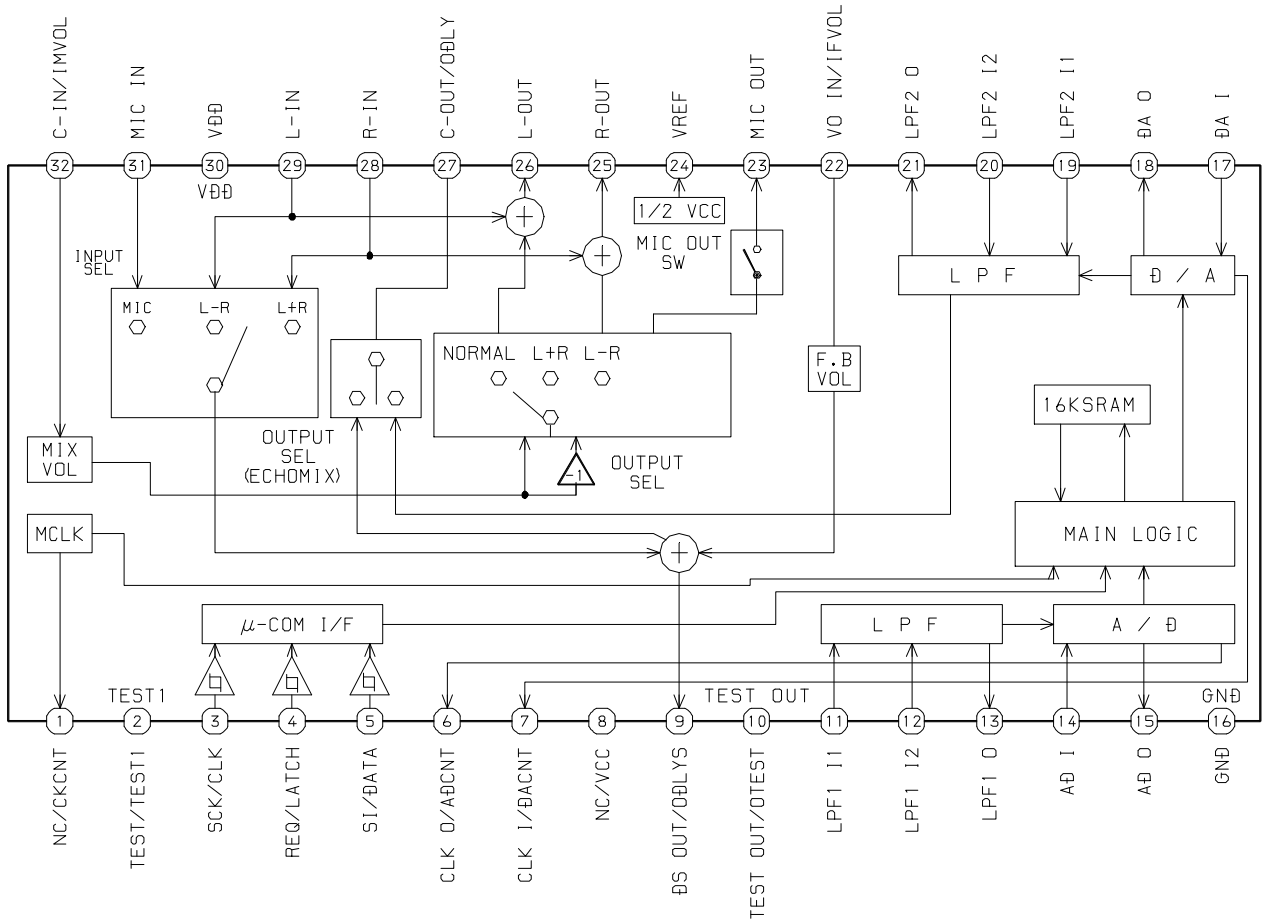

IC, BU2099FV

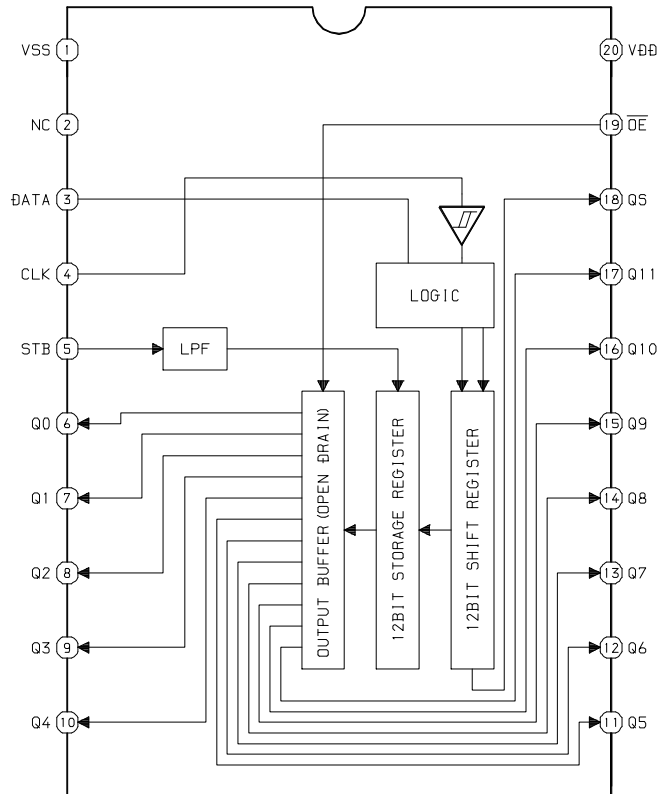

IC, M61506FP

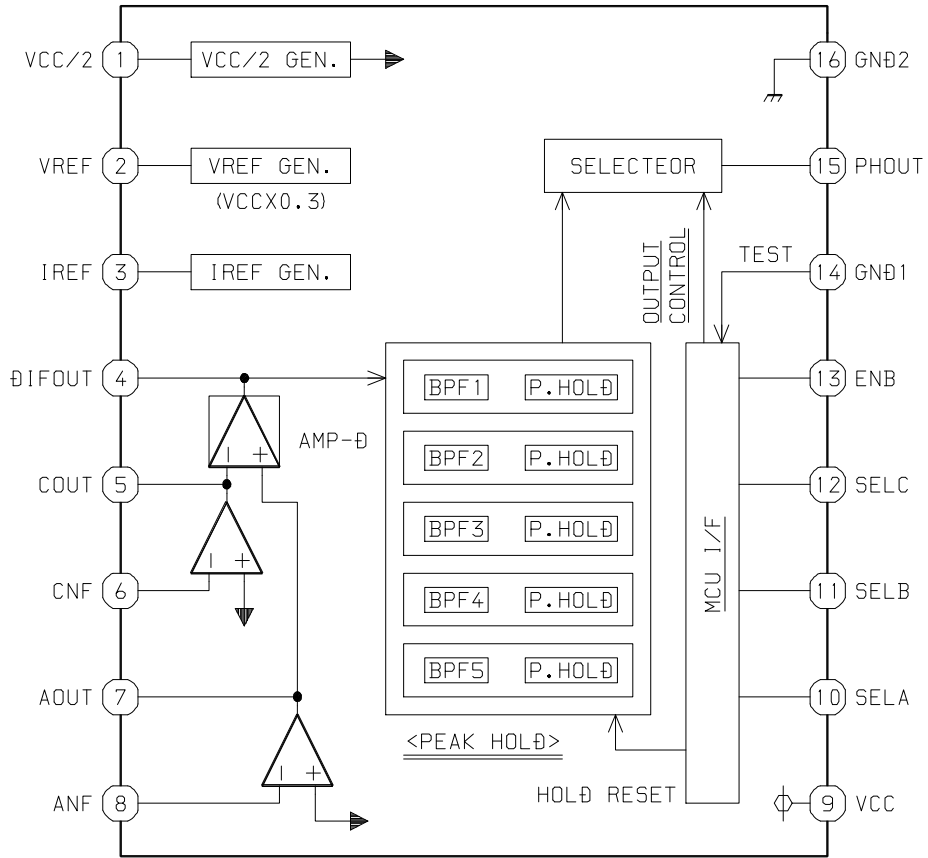

IC, BU9990-03FS

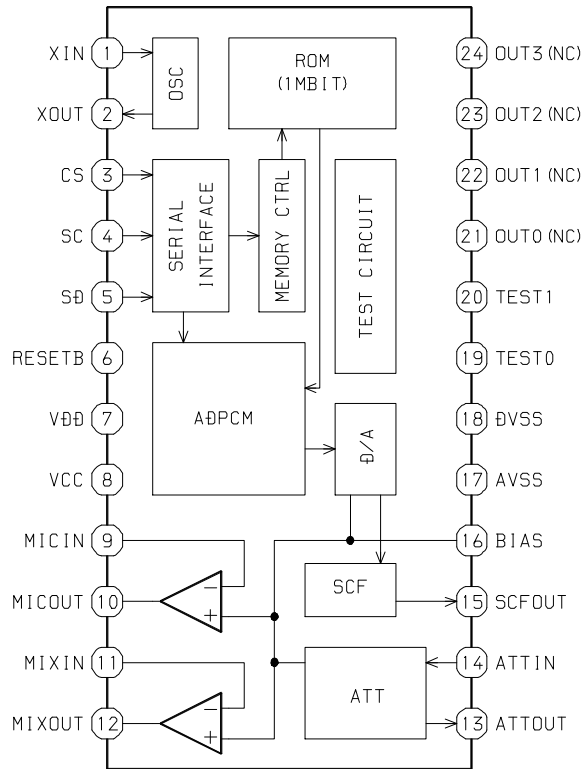

IC, BA7762AFS

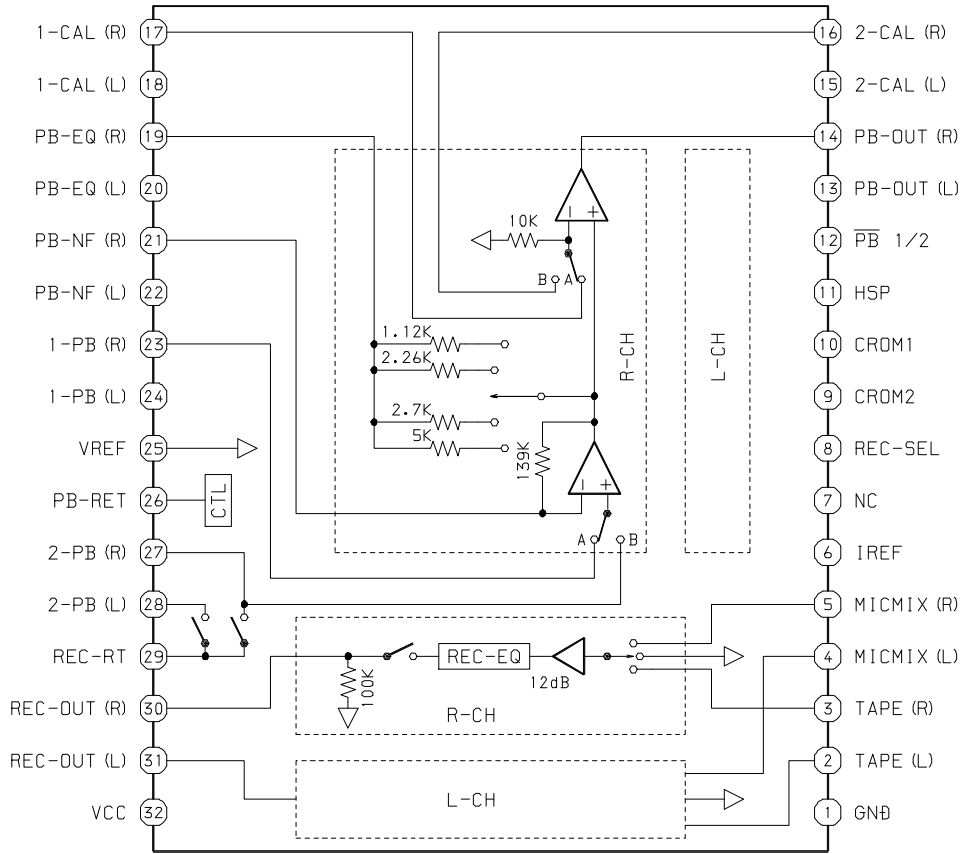

IC, LC72131D

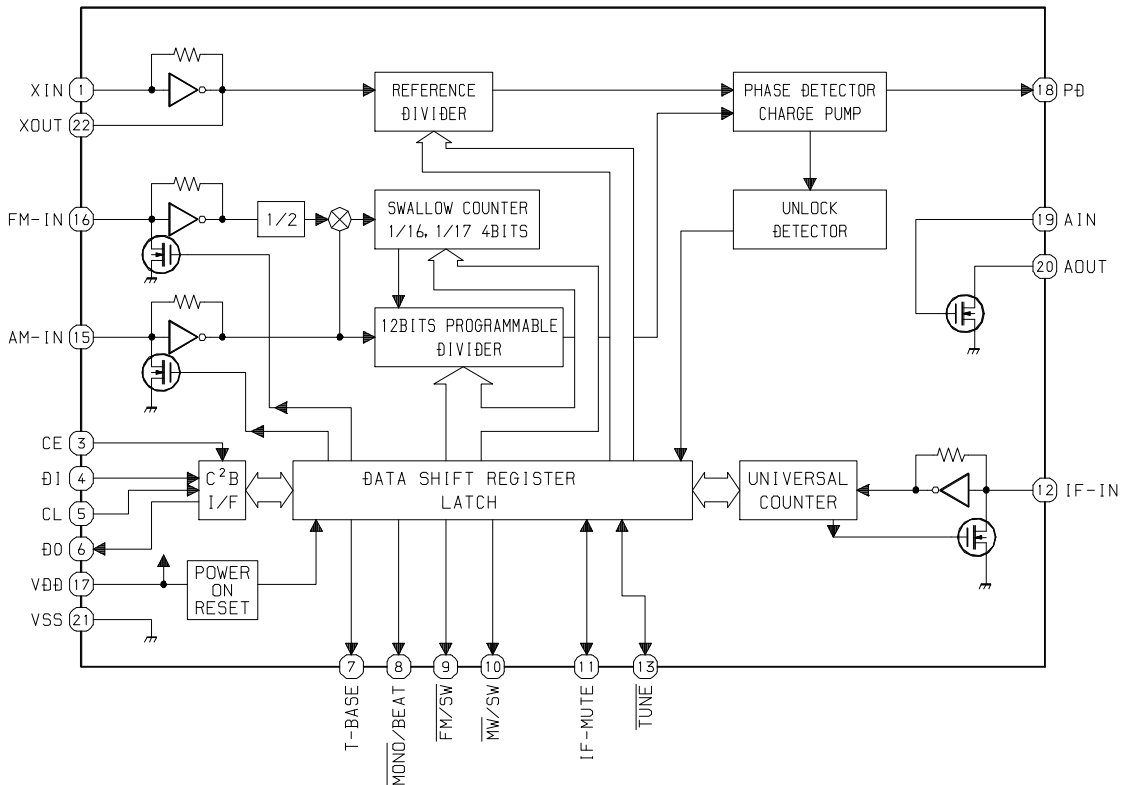

IC, LA1843

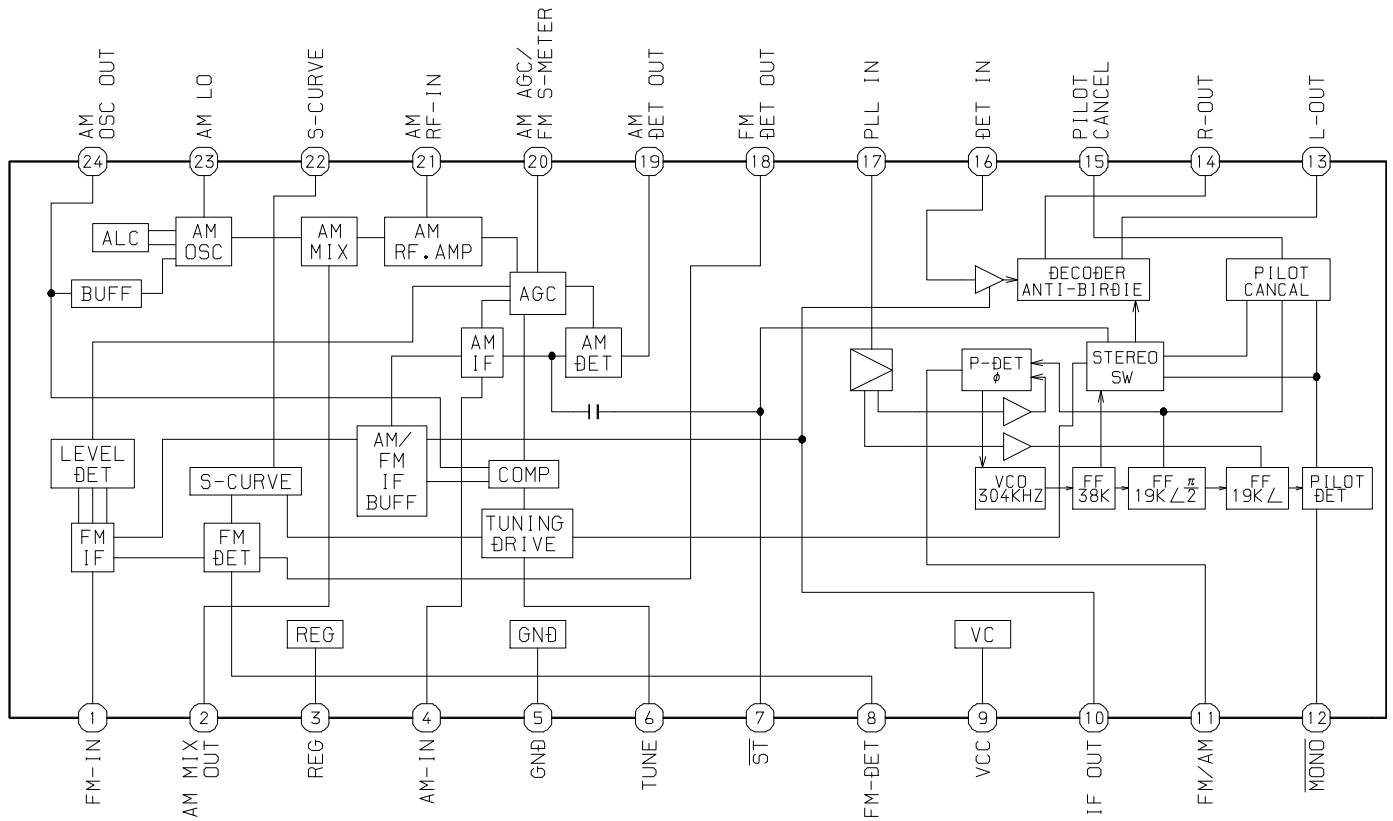

IC, BU2092F

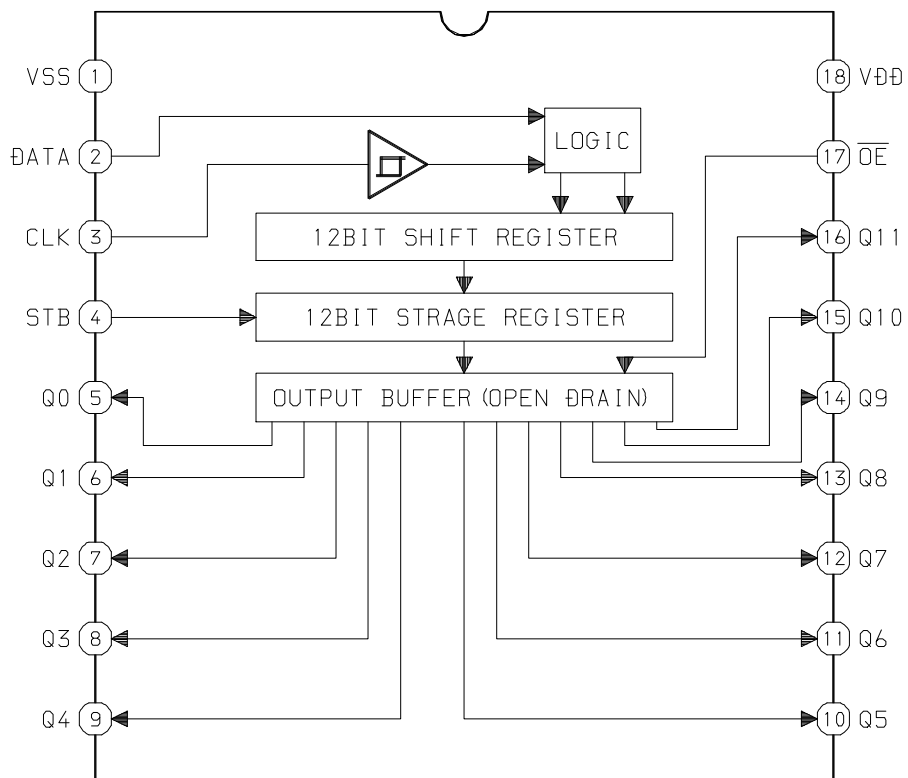

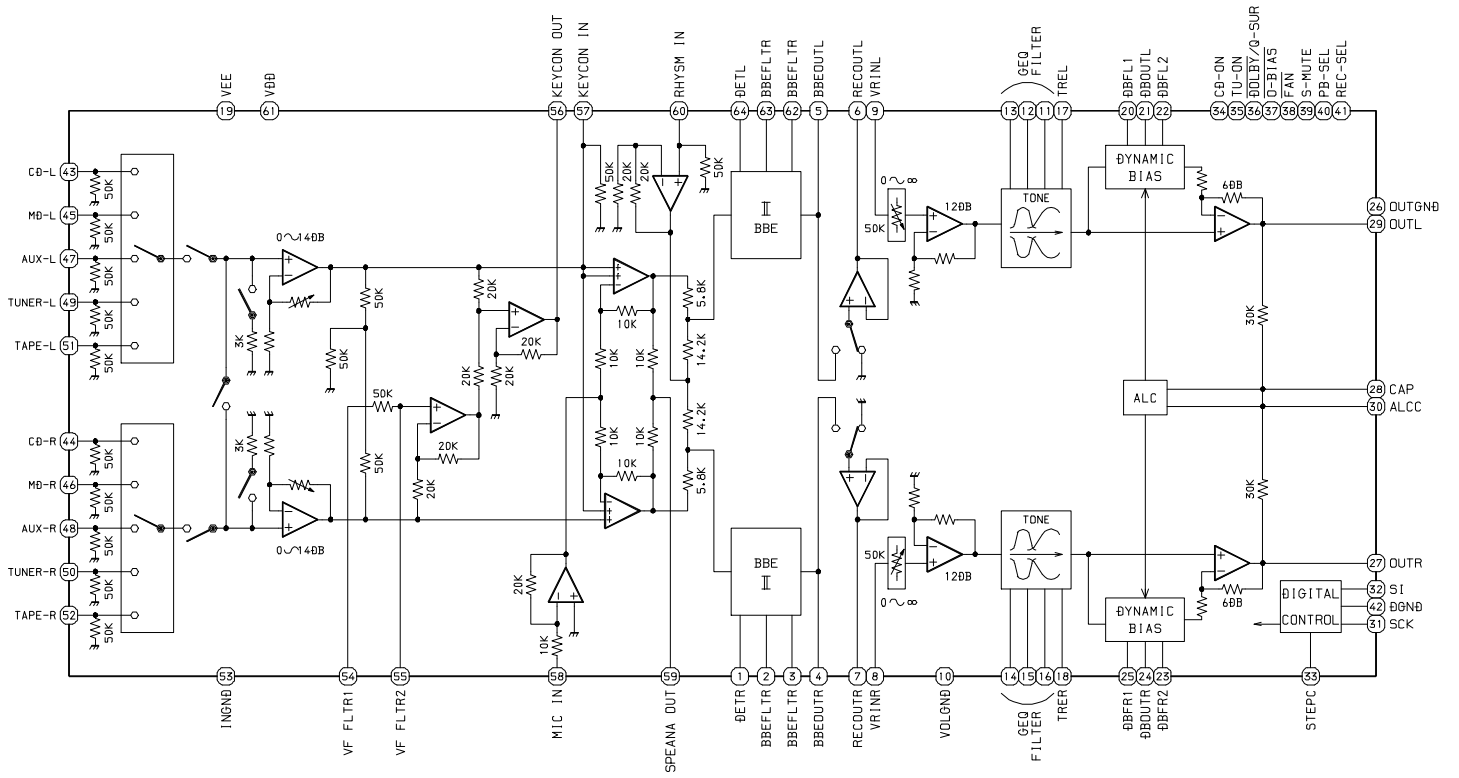

IC DESCRIPTION

IC, LC87654V-5P35

Pin No.	Pin Name	I/O	Description
1	O-CLK	O	CLOCK output for FRONT and MAIN C.B.
2	O-DATA	O	DATA output for FRONT and MAIN C.B.
3	O-STB(M)	O	Strobe output for MAIN C.B.
4	O-POWER	O	System power ON/OFF output.
5	O-STB(SHIFT)	O	Strobe output for shift register.
6	O- $\overline{\text{RYM-CS}}$	O	Chip select output for RHYTHM IC.
7	O-PLL-CE	O	Chip enable output for PLL.
8	I-STEREO	I	Stereo detect input.
9	O- $\overline{\text{CLK SHIFT}}$	O	Tuner clock shift output (active L).
10	I- $\overline{\text{HP-MUTE}}$	I	Head phones connect detect input.
11	$\overline{\text{RESET}}$	I	Reset input for MICON.
12	I-DISH	I	CD turntable photo sensor input.
13	I-SPEANA	I	SPEANA level AD input.
14	VSS1	-	Connected to GND.
15	CF1	-	To oscillator circuit.
16	CF2	-	To oscillator circuit.
17	VDD1	-	Power supply.
18	I-HOLD	I	HOLD input .
19	I-KEY1	I	Key-1 AD input.
20	I-KEY2	I	Key-2 AD input.
21	I-KEY3	I	Key-3 AD input.
22	I-CDSW	I	CD nechanical switch input.
23	I-RTVR	I	Rotary encoder AD input for VR.
24	I-JOG	I	Rotary encoder AD input for MULTI JOG.
25	I-MIC	I	MIC input for AUTO VOCAL FADER.
26	I- $\overline{\text{MS}}$	I	DECK MS detect input.
27	I-TM-BASE	I	Standard time input (8Hz).
28	I-WRQ	I	CD WRQ input.
29	I-RMC	I	System remote controller input.
30 ~ 42	G13 ~ G1	O	FL grid output (G13 ~ G1).
43 ~ 45	P35 ~ P33	O	FL segment output (P35 ~ P33).
46	VDD3	-	Power supply.
47	P32/SPEANA-A	O	FL segment output (P32)/SPEANA band change output (A).
48	P31/SPEANA-B	O	FL segment output (P31)/SPEANA band change output (B).
49	P30/SPEANA-C	O	FL segment output (P30)/SPEANA band change output (C).
50	P29/ $\overline{\text{BEAT-M}}$	O/I	FL segment output (P29)/BEAT MASTER less diode input.
51	-VP	-	Connected to -VFL .
52	P28/AM-ST	O/I	FL segment output (P28)/AM-STEREO diode input (Not used).
53	P27/LW	O/I	FL segment output (P27)/LW diode input (Not used).
54	P26/SW	O/I	FL segment output (P26)/SW diode input (Not used).
55	P25/FM1	O/I	FL segment output (P25)/FM1diode input (Not used).
56	P24/CASINO DEMO	O/I	FL segment output (P24)/initial CASINO DEMO diode input.

Pin No.	Pin Name	I/O	Description
57	P23/ $\overline{\text{ECO MODE}}$	O/I	FL segment output (P23)/Initial ECO MODE less diode input.
58	P22/ $\overline{\text{DSP}}$	O/I	FL segment output (P22)/DSP less diode input (Not used).
59	P21/ $\overline{\text{PRO/5.1}}$	O/I	FL segment output (P21)/PRO-LOGIC 5.1CH diode input (Not used).
60	P20/ $\overline{\text{KEY-CON}}$	O/I	FL segment output (P20)/KEY CONTROL diode input (Not used).
61	P19/ $\overline{\text{DOLBY}}$	O/I	FL segment output (P19)/DECK DOLBY diode input (Not used).
62	P18/ $\overline{\text{PRO}}$	O/I	FL segment output (P18)/PROLOGIC diode input (Not used).
63	P17/ $\overline{\text{AM10K}}$	O/I	FL segment output (P17)/AM10 change diode input.
64	P16/ $\overline{\text{CST2}}$	O/I	FL segment output (P16)/DECK 2 cassette detect SW input.
65	P15/ $\overline{\text{REB}}$	O/I	FL segment output (P15)/DECK side B record permission SW input.
66	P14/ $\overline{\text{CAM2}}$	O/I	FL segment output (P14)/DECK 2 CAM SW input.
67	P13/ $\overline{\text{AUTO1}}$	O/I	FL segment output (P13)/DECK 1 auto stop input.
68	P12/ $\overline{\text{AUTO2}}$	O/I	FL segment output (P12)/DECK 2 auto stop input.
69	P11/ $\overline{\text{CAM1}}$	O/I	FL segment output (P11)/DECK 1 CAM SW input.
70	P10/ $\overline{\text{CST1}}$	O/I	FL segment output (P10)/DECK 1 cassette detect SW input.
71	P9/ $\overline{\text{REA}}$	O/I	FL segment output (P9)/DECK side A record permission SW input.
72	VDD4	–	Power supply.
73	P8/ $\overline{\text{AC DEMO}}$	O/I	FL segment output (P8)/DEMO less (on the shop) diode input (Not used).
74~80	P7~P1	O	FL segment output (P7~P1).
81	NC	–	Not connected.
82	O-TRAY CLOSE	O	CD tray close output.
83	O-TRAY-OPEN	O	CD tray open output.
84	I-SUBQ	I	CD SUBQ detect input.
85	O-DISH-FWD	O	CD turntable forward revolution output.
86	O-DISH-REV	O	CD turntable reverse revolution output.
87	O-DATA	O	CD data output.
88	$\overline{\text{O-LED-STBY}}$	O	STBY LED on output (STBY LED on during O-POWER OFF).
89	VSS2	–	Connected to GND.
90	VDD2	–	Power supply.
91	$\overline{\text{O-MOTOR}}$	O	DECK motor output.
92	O-MUTE	O	System mute ON/OFF output.
93	$\overline{\text{O-SOL1}}$	O	DECK 1 plunger $\overline{\text{ON/OFF}}$ output.
94	$\overline{\text{O-SOL2}}$	O	DECK 2 plunger $\overline{\text{ON/OFF}}$ output.
95	I-DRF	I	CD DRF input.
96	I-IFC	I	TUNER IFC input.
97	NC	–	Connected to GND.
98	O-CD CLK	O	CD CLK output.
99	O-CD-CE	O	CD CE output.
100	$\overline{\text{O-KSCAN}}$	O	Key scan timing output.

ADJUSTMENT <TUNER / DECK / FRONT>

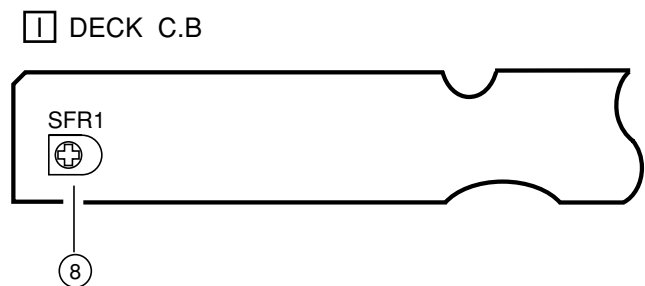
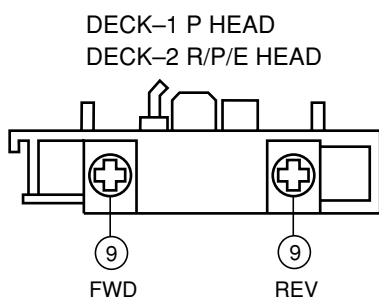
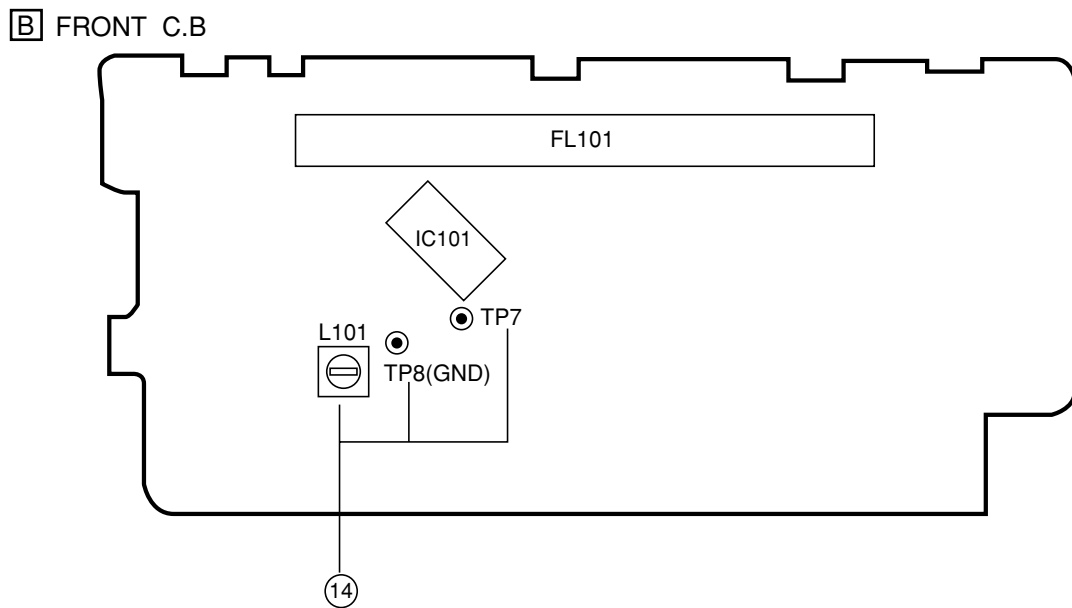
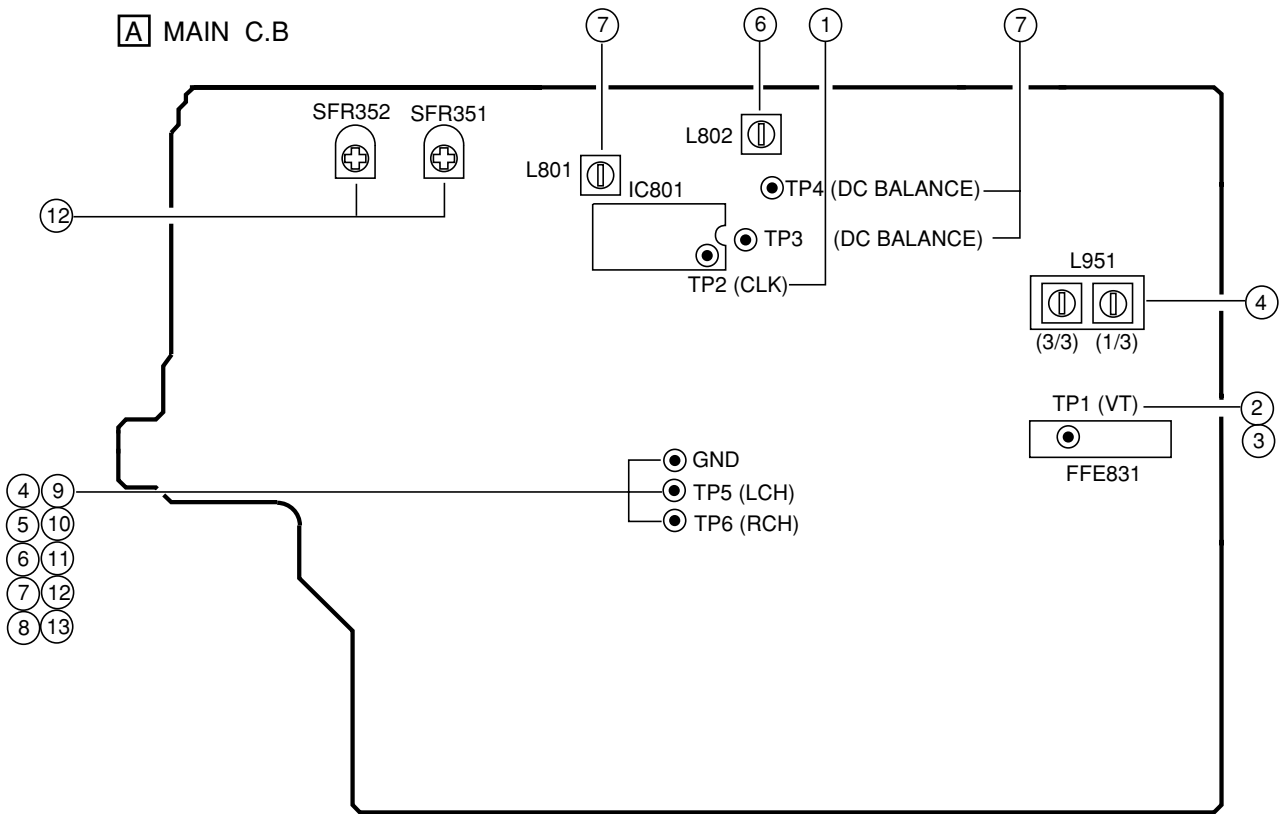

< TUNER SECTION >

1. Clock frequency Check
Settings : • Test point : TP2
Method : Set to AM 1710kHz and check that the test point is 2160kHz \pm 45Hz.
2. AM VT Check
Settings : • Test point : TP1 (VT)
Method : Set to AM 1710kHz, 530kHz and check that the test point is less than 8.5V (1710kHz) and more than 0.6V (530kHz).
3. FM VT Check
Settings : • Test point : TP1 (VT)
Method : Set to FM 87.5MHz, 108.0MHz and check that the test point is more than 0.5V (87.5MHz) and less than 8.0V (108.0MHz).
4. AM Tracking Adjustment
Settings : • Test point : TP5(Lch), TP6(Rch)
• Adjustment location :
L951(1/3) 1000kHz
Method : Set to AM 1000kHz and adjust L951(1/3) to MAX.
5. FM Tracking Check
Settings : • Test point : TP5(Lch), TP6(Rch)
Method : Set to FM 98.0MHz and check that the test point is less than 9dB μ V.
6. AM IF Adjustment
Settings : • Test point : TP5(Lch), TP6(Rch)
• Adjustment location :
L802 450kHz
7. DC Balance / Mono Distortion Adjustment
Settings : • Test point : TP3, TP4 (DC Balance)
: TP5(Lch), TP6(Rch) (Distortion)
• Adjustment location : L801
• Input level : 60dB μ V
Method : Set to FM 98.0MHz and adjust L801 so that the voltage between TP3 and TP4 becomes 0V \pm 0.04V.
Next, check that the distortion is less than 1.3%.

< DECK SECTION >

8. Tape Speed Adjustment (DECK 2)
Settings : • Test tape : TTA-100
• Test point : TP5(Lch), TP6(Rch)
• Adjustment location : SFR1
Method : Play back the test tape and adjust SFR1 so that the frequency counter reads 3000Hz \pm 5Hz and \pm 45Hz (REV) with respect to forward speed.
9. Head Azimuth Adjustment (DECK 1, DECK 2)
Settings : • Test tape : TTA-330
• Test point : TP5(Lch), TP6(Rch)
• Adjustment location : Head azimuth adjustment screw
Method : Play back (FWD) the 8kHz signal of the test tape and adjust screw so that the output becomes maximum. Next, perform on REV PLAY mode.
10. PB Frequency Response Check (DECK 1, DECK 2)
Settings : • Test tape : TTA-300
• Test point : TP5(Lch), TP6(Rch)
Method : Play back the 315Hz and 10kHz signals of the test tape and check that the output ratio of the 10kHz signal with respect to that of the 315Hz signal is 0dB \pm 3dB.
11. PB Sensitivity Check (DECK 1, DECK 2)
Settings : • Test tape : TTA-200
• Test point : TP5(Lch), TP6(Rch)
Method : Play back the test tape and check that the output level of the test point is 400mV \pm 3dB.
12. REC/PB Frequency Response Adjustment (DECK 2)
Settings : • Test tape : TTA-602
• Test point : TP5(Lch), TP6(Rch)
• Input signal : 1kHz / 10kHz (LINE IN)
• Adjustment location : SFR351 (Lch)
SFR352 (Rch)
Method : Apply a 1kHz signal and REC mode. Then adjust OSC attenuator so that the output level at the TP5, TP6 becomes 28mV. Record and play back the 1kHz and 10kHz signals and adjust SFRs so that the output of the 10kHz signals becomes 0dB \pm 0.5dB with respect to that of the 1kHz signal.
13. REC/PB Sensitivity Check (DECK 2)
Settings : • Test tape : TTA-602
• Test point : TP5(Lch), TP6(Rch)
• Input signal : 1kHz (LINE IN)
Method : Apply a 1kHz signal and REC mode. Then adjust OSC attenuator so that the output level at TP5, TP6 becomes 280mV. Record and play back the 1kHz signals and check that the output is -1dB \pm 3.0dB.

< FRONT SECTION >

14. μ -CON OSC Adjustment
Settings : • Test point : TP7 and TP8 (GND)
• Adjustment location : L101
Method : Insert AC plug while pressing TUNER function key. Adjust L101 so that the frequency at the test point is 208.80Hz \pm 0.2Hz.

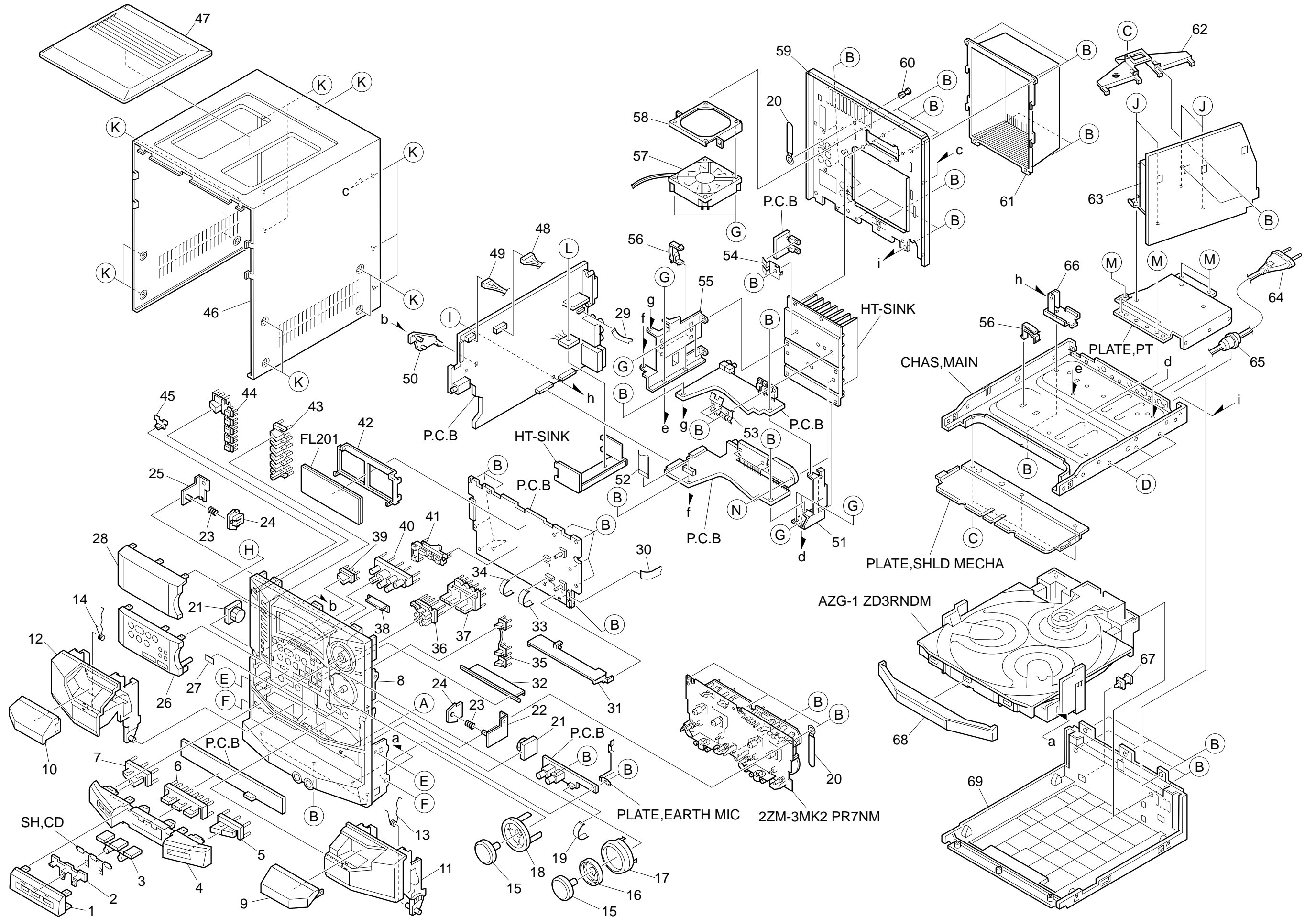

MECHANICAL PART LIST 1 / 1

REF. NO.	PART NO.	KANRI NO.	DESCRIPTION	REF. NO.	PART NO.	KANRI NO.	DESCRIPTION
1	8A-NF6-010-010		PANEL, DIRECT	45	8A-NF6-042-010		REFLECTOR, ECO
2	8A-NF6-044-010		REFLECTOR, CD	46	8A-NF6-004-010		CABI, STEEL
3	8A-NF6-205-010		GUIDE, CD	47	8A-NF6-005-010		PANEL, TOP
4	8A-NF6-009-010		PANEL, CD	48	87-NF6-616-010		CONN ASSY, 8P RPB
5	8A-NF6-037-010		KEY, CD OPEN	49	87-NF6-615-010		CONN ASSY, 3P PB
6	8A-NF6-035-010		KEY, CD DIRECT	50	8A-NF8-206-010		HLDR, PWB M
7	8A-NF6-036-010		KEY, CD EDIT	51	8A-NF6-214-010		HLDR, HT-SINK R
8	8A-NF6-002-010		CABI, FR H<EXCEPT 80U>	52	88-907-151-110		FF-CABLE, 7P 1.25 150MM
8	8A-NF6-001-010		CABI, FR U<80U>	53	8A-NF6-210-010		HLDR, IC6
9	8A-NF6-019-010		WINDOW, CASS 2	54	8A-NF7-226-010		HLDR, IC2-T2
10	8A-NF6-018-010		WINDOW, CASS 1	55	8A-NF6-213-010		HLDR, HT-SINK L
11	8A-NF6-007-010		BOX, CASS 2	56	87-NF4-221-010		HLDR, CABLE
12	8A-NF6-006-010		BOX, CASS 1	57	87-A91-711-010		FAN, 3110GL-B4W-B34-H02<EXCEPT 80U>
13	82-NF5-219-010		SPR-T, EJECT 2 (SIN)	58	8A-NF6-219-010		HLDR, FAN<EXCEPT 80U>
14	82-NF5-218-010		SPR-T, EJECT 1 (SIN)	59	8A-NF6-052-010		PANEL, REAR LH<EXCEPT 80U>
15	8A-NF6-030-010		KNOB, RTRY JOG	59	8A-NF6-051-010		PANEL, REAR U<80U>
16	8A-NF6-040-010		REFLECTOR, VOL	60	87-084-077-010		NYLON RIVET, 3.5-4.5
17	8A-NF6-041-010		RING, VOL	61	8A-NF6-082-010		COVER, REAR LHSM<80LH>
18	8A-NF6-029-010		KEY, GEQ	61	8A-NF6-087-010		COVER, REAR LHSM Z83<83LH>
19	88-905-281-110		FF-CABLE, 5P 1.25 280MM	61	8A-NF6-086-010		COVER, REAR SPEC LABEL<80HA>
20	87-064-185-010		HLDR, WIRE	61	8A-NF6-110-010		COVER, REAR ST USM<80U>
21	8Z-NF6-210-010		DMPR, 150 N	62	8A-NF6-217-010		HLDR, PWB PT<80LH, 83LH>
22	87-NF4-217-110		HLDR, LOCK 2	62	8A-NF6-228-010		HLDR, PWB PT 96-75<80U, 80HA>
23	86-NF9-224-010		SPR-C, LOCK	63	8A-NF6-622-010		PT, LH EI96-60 ANF-6<EXCEPT 80U>
24	82-NF5-229-010		PLATE, LOCK	63	8A-NF6-621-010		PT, U EI96-60 ANF-6<80U>
25	87-NF4-216-010		HLDR, LOCK 1	△	64	87-A80-105-010	AC CORD ASSY, AZ<80HA>
26	8A-NF6-012-010		PANEL, FR H<EXCEPT 80U>	△	64	87-A80-092-010	AC CORD ASSY, E BLK SUN<80LH, 83LH>
26	8A-NF6-011-010		PANEL, FR U<80U>	△	64	87-A80-110-010	AC CORD ASSY, U SPT-2W<80U>
27	81-532-080-010		LABEL, CASS. COMPT	65	87-085-185-010		BUSHING, AC CORD (E)<EXCEPT 80U>
28	8A-NF6-059-010		WINDOW, DISP H Z80E<80HA>	65	87-085-189-010		BUSHING, CORD (U)<80U>
28	8A-NF6-016-010		WINDOW, DISPLAY H<80LH>	66	8A-NF7-209-010		HLDR, PWB-M BTM
28	8A-NF6-014-010		WINDOW, DISPLAY H Z83<83LH>	67	84-ZG1-245-210		CAP, OPTICAL
28	8A-NF6-015-010		WINDOW, DISPLAY U<80U>	68	8A-NF6-008-010		PANEL, TRAY
29	88-906-621-110		FF-CABLE, 6P 1.25 620MM	69	8A-NF6-003-010		CABI, BOTTOM
30	88-913-521-110		FF-CABLE, 13P 1.25 520MM	A	87-067-758-010		BVT2+3-12 W/O SLOT
31	8A-NF6-204-010		GUIDE, DECK	B	87-067-703-010		TAPPING SCREW, BVT2+3-10
32	8A-NF6-039-010		REFLECTOR, DECK	C	87-067-688-010		BVTT+3-6
33	88-915-111-110		FF-CABLE, 15P 1.25	D	87-591-095-410		TAPPING SCREW, QIT+3-8 (GLD)
34	88-907-421-110		FF-CABLE, 7P 1.25 420MM	E	87-591-094-410		TAPPING SCREW, QIT+3-6
35	8A-NF6-022-010		KEY, ECHO	F	87-721-097-410		QT2+3-12 GLD
36	8A-NF6-031-010		KEY, BBE U<EXCEPT 80U>	G	87-067-579-010		TAPPING SCREW, BVT2+3-8
36	8A-NF6-047-010		KEY, T-BASS U<80U>	H	87-723-096-410		QT2+3-10W/O SLOT BL
37	8A-NF6-034-010		KEY, SPICE<EXCEPT 80U>	I	87-NF4-224-010		S-SCREW, IT3B+3-8 CU
38	8A-NF6-038-010		REFLECTOR, FL	J	87-067-975-010		S-SCREW, IT+4-8
39	8A-NFT-007-010		KEY, ASSY PRO	K	87-B10-091-010		UTT2+3-10 W/O BLK
40	8A-NF6-026-010		KEY, ASSY OPE	L	87-067-001-010		S-SCREW, BVWST2+3-12W/O SL
41	8A-NF6-203-010		GUIDE, OPE	M	87-078-191-010		S-SCREW, IT+4-10
42	8A-NF6-201-010		GUIDE, FL	N	87-067-581-010		TAPPING SCREW, BVT2+3-15
43	8A-NF6-023-010		KEY, ASSY FUN				
44	8A-NF6-045-010		KEY, ASSY POWER				

COLOR NAME TABLE

Basic color symbol	Color	Basic color symbol	Color	Basic color symbol	Color
B	Black	C	Cream	D	Orange
G	Green	H	Gray	L	Blue
LT	Transparent Blue	N	Gold	P	Pink
R	Red	S	Silver	ST	Titan Silver
T	Brown	V	Violet	W	White
WT	Transparent White	Y	Yellow	YT	Transparent Yellow
LM	Metallic Blue	LL	Light Blue	GT	Transparent Green
LD	Dark Blue	DT	Transparent Orange	GM	Metallic Green
YM	Metallic Yellow	DM	Metallic Orange		

TAPE MECHANISM EXPLODED VIEW 1 / 1

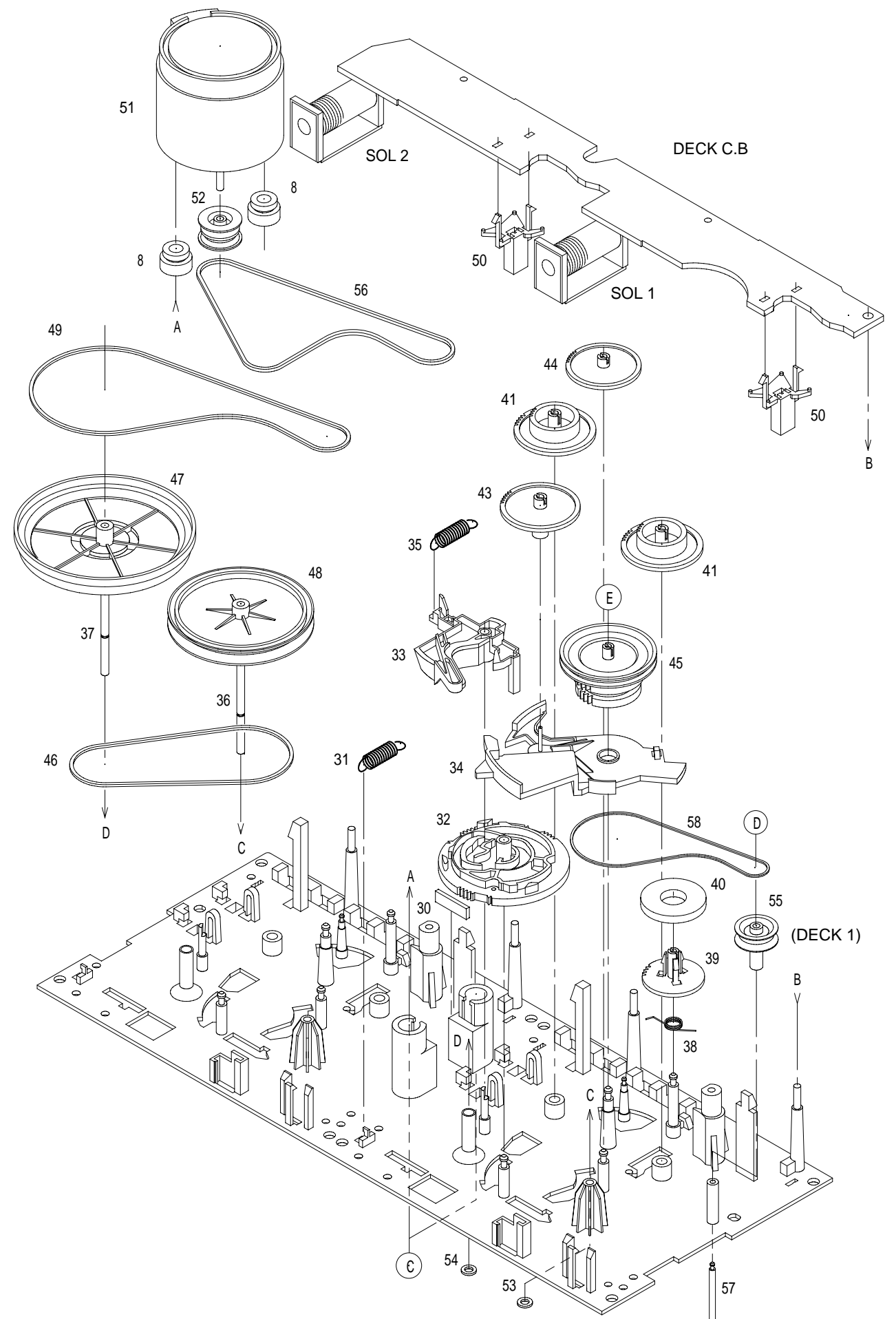
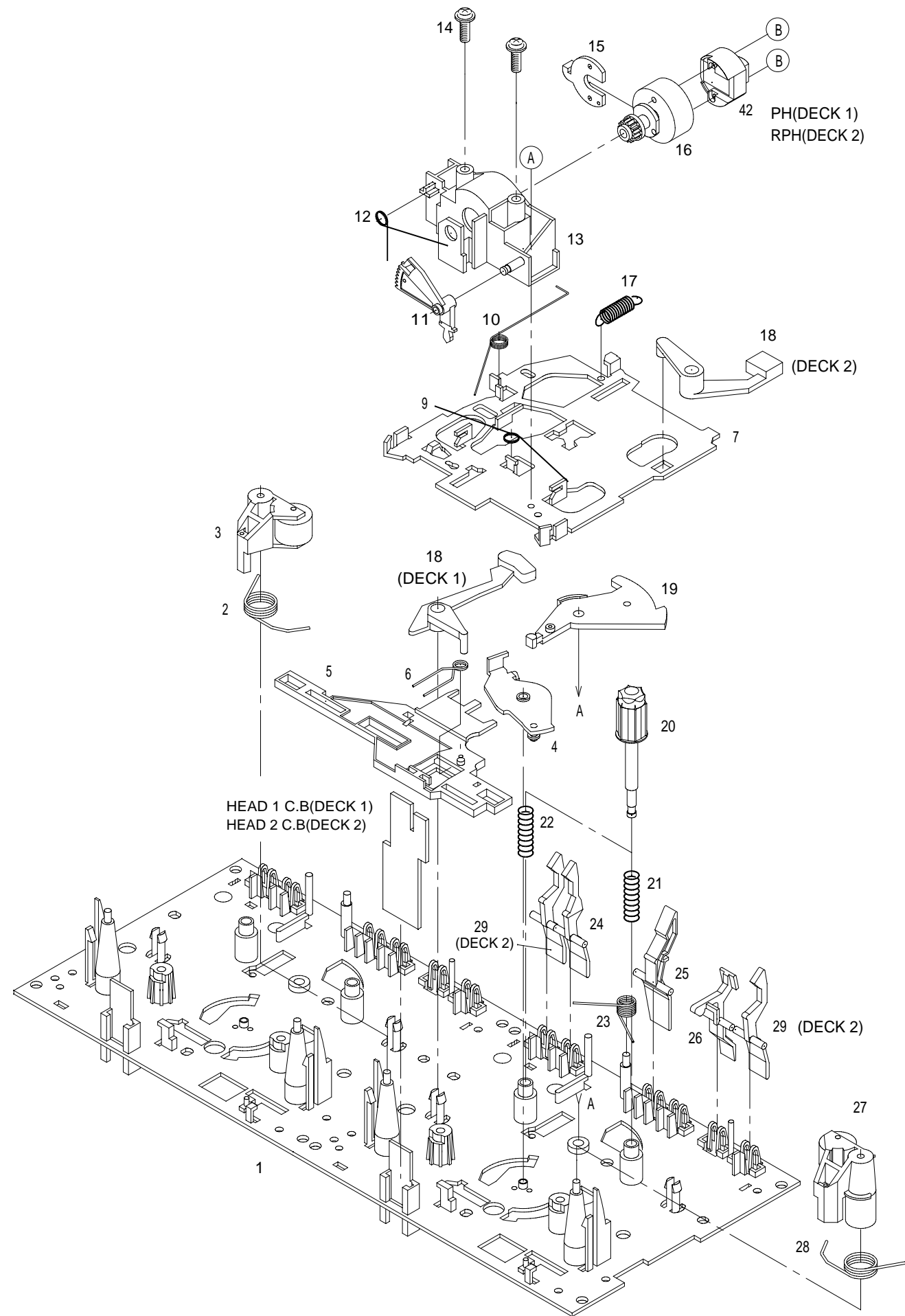

TAPE MECHANISM PART LIST 1 / 1

REF. NO.	PART NO.	KANRI NO.	DESCRIPTION	REF. NO.	PART NO.	KANRI NO.	DESCRIPTION
1	82-ZM3-301-619		CHAS ASSY,M2	35	82-ZM1-265-310		SPR-E,TRIG
2	82-ZM1-258-219		SPR-T,PINCH L	36	82-ZM1-236-019		CAPSTAN N 2-41.5
3	82-ZM1-341-219		LVR ASSY,PINCH L2	37	82-ZM1-239-019		CAPSTAN N 2.2-41.7
4	82-ZM1-333-110		PLATE,LINK 2	38	82-ZM1-322-019		SPR-T,FR60
5	82-ZM1-266-310		LVR,DIR	39	82-ZM1-220-219		GEAR,IDLER
6	82-ZM1-214-919		SPR-T,DIR	40	82-ZM3-616-019		RING MAGNET 4
7	82-ZM1-206-81K		CHAS,HEAD	41	82-ZM1-216-519		GEAR,REEL
8	82-ZM3-307-019		CUSH-G,DIA3.7-8-3.2	42	87-A91-196-010		HEAD,PH KP9142
9	82-ZM1-269-219		SPR-T,BRG	42	87-A91-195-010		HEAD,RPH KC9142
10	82-ZM1-219-119		SPR-T,LINK	43	82-ZM1-225-21K		GEAR,FR
11	82-ZM1-210-119		GEAR,H T	44	82-ZM1-226-019		GEAR,REW
12	82-ZM3-353-010		SPR-T,HEAD	45	82-ZM3-333-310		SLIP DISK ASSY 2
13	82-ZM1-207-919		GUIDE,TAPE	46	82-ZM1-338-110		BELT FR4
14	86-ZM4-206-110		S-SCREW,AZIMUTH	47	82-ZM1-349-110		FLY-WHL,R W(DECK 2)
15	82-ZM1-314-119		PLATE,HEAD	47	82-ZM3-338-310		FLY-WHL,R3 W(DECK 1)
16	82-ZM1-208-319		HLDR,HEAD	48	82-ZM1-348-110		FLY-WHL,L W(DECK 2)
17	82-ZM1-218-019		SPR-E,HB	48	82-ZM1-348-110		FLY-WHL,L W(DECK 1)
18	82-ZM1-263-110		LVR,EJECT L (DECK 1)	49	82-ZM3-329-410		BELT,SBU R2
18	82-ZM1-264-010		LVR,EJECT R (DECK 2)	50	82-ZM1-245-210		HLDR,IC
19	82-ZM1-222-21K		LVR,PLAY	51	87-045-347-019		MOT,SHU2L 70(M1)
20	82-ZM1-217-419		REEL TABLE	52	82-ZM3-221-210		PULLEY,MOT 2M
21	82-ZM1-244-510		SPR-C,BT	53	82-ZM1-288-019		SH,1.63-3.2-0.5 SLT
22	82-ZM1-285-410		SPR-C,BT L	54	80-ZM6-243-019		SH,1.75-3.6-0.5 SLT
23	82-ZM1-257-019		SPR-T,CAS	55	82-ZM3-335-310		PULLEY,COUPLER M3(DECK 1)
24	82-ZM1-241-319		LVR,MC	56	82-ZM3-342-010		BELT,SBU MOT 2
25	82-ZM1-242-019		LVR,CAS	57	82-ZM3-339-110		SHAFT,COUPLER N3(DECK 1)
26	82-ZM1-243-019		LVR,STOP	58	86-ZM1-206-010		BELT,MAIN L
27	82-ZM1-344-219		LVR ASSY,PINCH R2	A	85-ZM3-202-010		S-SCREW,TG
28	82-ZM1-259-219		SPR-T,PINCH R	B	80-ZM6-207-110		V+1.6-7
29	82-ZM1-240-119		LVR,REC (DECK 2)	C	82-ZM3-318-110		S-SCRW MOTOR M2
30	82-ZM3-340-010		SH,BELT D2	D	87-B10-043-010		W-P,0.99-4-0.25 SLT
31	82-ZM1-255-319		SPR-E,LVR DIR	E	82-ZM3-334-010		PW,2.16-6-0.4
32	82-ZM3-305-310		GEAR,CAM M2				
33	82-ZM1-227-319		LVR,TRIG				
34	82-ZM3-306-11K		LVR,FR M2				

SPRING APPLICATION POSITION

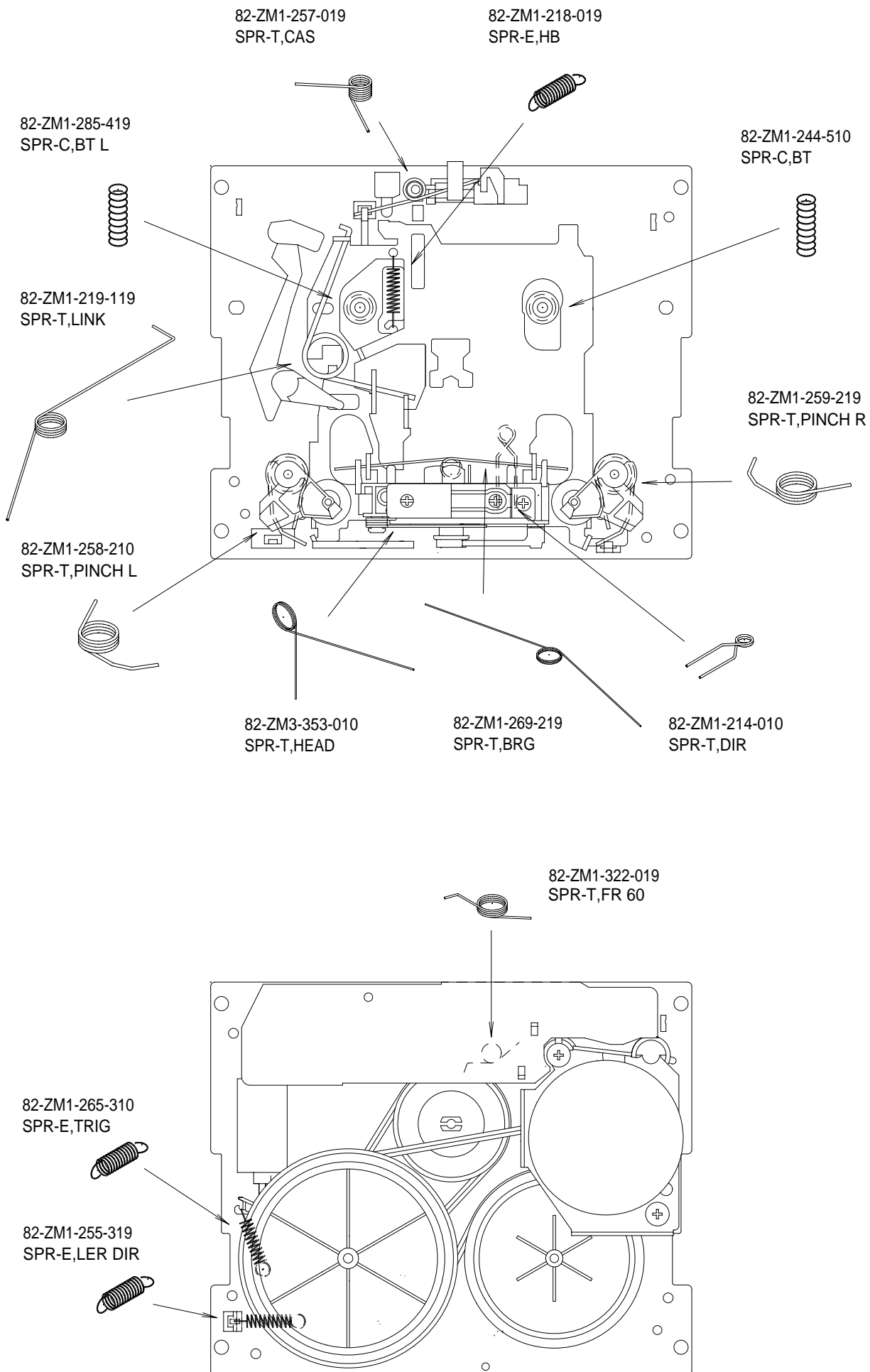

SPEAKER DISASSEMBLY INSTRUCTIONS

Type.1

Insert a flat-bladed screwdriver into the position indicated by the arrows and remove the panel. Remove the screws of each speaker unit and then remove the speaker units.

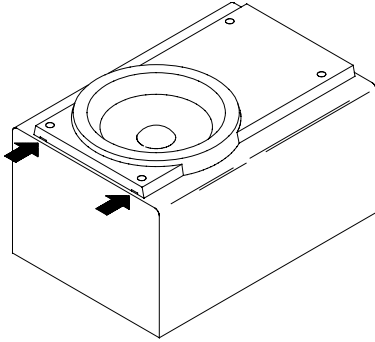

Type.2

Remove the grill frame and four pieces of rubber caps by pulling out with a flat-bladed screwdriver. Remove the screws from hole where installed rubber caps. Insert a flat-bladed screwdriver into the position indicated by the arrows and remove the panel. Remove the screws of each speaker unit and then remove the speaker units.

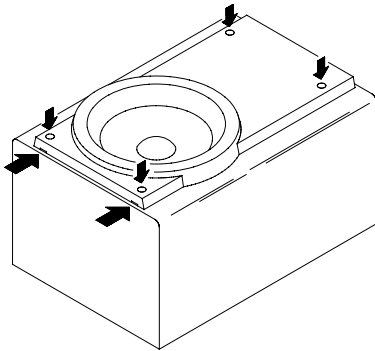

Type.3

Insert a flat-bladed screwdriver into the position indicated by the arrows and remove the panel. Turn the speaker unit to counter-clockwise direction while inserting a flat-bladed screwdriver into one of the hollows around speaker unit, and then remove the speaker unit. After replacing the speaker unit, install it turning to clockwise direction until "click" sound comes out.

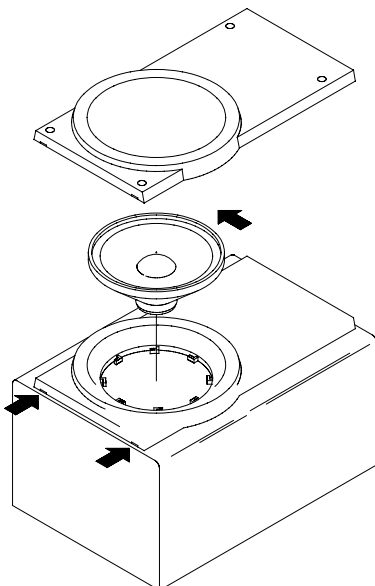

Type.4

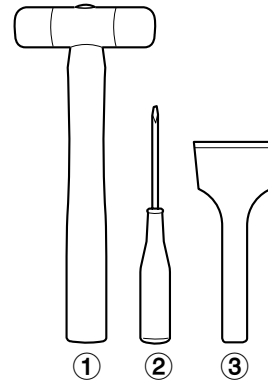

TOOLS

- ① Plastic head hammer
- ② (⊖) flat head screwdriver
- ③ Cut chisel

How to Remove the PANEL, FR

1. Insert the (⊖) flat head screwdriver tip into the gap between the PANEL, FR and the PANEL, SPKR. Tap the head of the (⊖) flat head screwdriver with the plastic hammer head, and create the clearance as shown in Fig-1.
2. Insert the cut chisel in the clearance, and tap the head of the cut chisel with plastic hammer as shown in Fig-2, to remove the PANEL, FR.
3. Place the speaker horizontally. Tap head of the cut chisel with plastic hammer as shown in Fig-3, and remove the PANEL, FR completely.

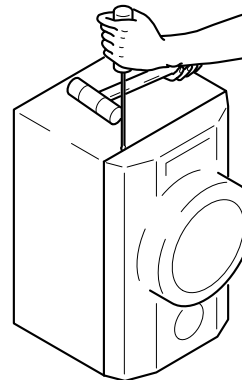

Fig-1

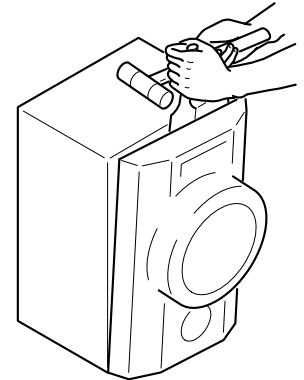

Fig-2

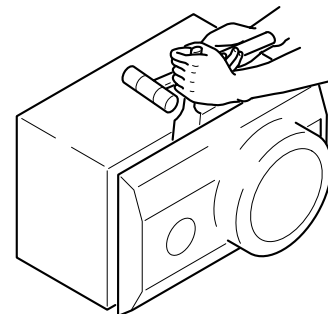

Fig-3

How to Attach the PANEL, FR

Attach the PANEL, FR to the PANEL, SPKR. Tap the four corners of the PANEL, FR with the plastic hammer to fit the PANEL, FR into the PANEL, SPKR completely.

SPEAKER PARTS LIST SX-WNSZ80 (YLSL,YLSC9)

REF. NO.	PART NO.	KANRI NO.	DESCRIPTION	REF. NO.	PART NO.	KANRI NO.	DESCRIPTION
1	8A-NS0-001-010		PANEL,FR	11	88-NS5-610-010		CORD,SPKR
2	8A-NS0-004-010		PANEL,DUCT	12	88-NS5-611-010		CORD,SPKR B/L
3	8A-NS0-005-010		PANEL, TOP	13	8A-NS6-002-010		PANEL,FR(SX-S80)
4	8A-NS0-006-010		PANEL,NAME	14	8A-NS6-004-010		GRILLE,FRAME ASSY(SX-S80)
5	8A-NS0-007-010		GRILLE,FRAME ASSY	15	8A-NS6-610-010		CORD,3.5(SX-S80)
6	8A-NS0-010-010		PROTECTOR,TWA	16	8A-NS6-606-010		SPKR,80(SX-S80)
7	8A-NS0-011-010		HLDL,PIEZO				
8	8A-NS6-602-010		SPKR,W 200				
9	8A-NS0-604-010		SPKR,M 120				
10	88-NSK-610-010		SPKR,CERAMIC ASSY				

SPEAKER PARTS LIST SX-WNH83 (YLML)

REF. NO.	PART NO.	KANRI NO.	DESCRIPTION	REF. NO.	PART NO.	KANRI NO.	DESCRIPTION
1	8A-NSY-001-010		PANEL,FR R	11	8A-NS6-004-010		GRILLE,FRAME ASSY(SX-S80)
2	8A-NSY-002-010		PANEL,FR L	12	8A-NS6-610-010		CORD,3.5(SX-S80)
3	8A-NSY-003-010		PANEL,BA R	13	8A-NS6-606-010		SPKR,80(SX-S80)
4	8A-NSY-004-010		PANEL,BA L	14	8A-NSY-010-010		CABI,M
5	8A-NSY-005-010		GRILLE,FRAME ASSY	15	8A-NSY-011-010		RING,W
6	8Z-NS5-602-010		SPKR,W 200	16	8A-NSY-012-010		COVER,REAR
7	8A-NS0-604-010		SPKR,M 120				
8	88-NS5-610-010		CORD,SPKR				
9	88-NS5-611-010		CORD,SPKR B/L				
10	8A-NS6-002-010		PANEL,FR(SX-S80)				

SPEAKER PARTS LIST SX-WNAJ85 (YUSL)

REF. NO.	PART NO.	KANRI NO.	DESCRIPTION	REF. NO.	PART NO.	KANRI NO.	DESCRIPTION
1	8A-NS2-001-010		PANEL,FR	11	88-NS5-610-010		CORD,SPKR
2	8A-NS2-002-010		PANEL,TW R	12	88-NS5-611-010		CORD,SPKR B/L
3	8A-NS2-003-010		PANEL,TW L	13	8A-NS6-002-010		PANEL,FR(SX-S80)
4	8A-NS2-004-010		PANEL,DUCT	14	8A-NS6-004-010		GRILLE,FRAME ASSY(SX-S80)
5	8A-NS2-013-010		PANEL,DUCT RING	15	8A-NS6-610-010		CORD,3.5(SX-S80)
6	8A-NS2-008-010		PROTECTOR,TW	16	8A-NS6-606-010		SPKR,80(SX-S80)
7	8A-NS2-009-010		GRILLE,FRAME ASSY				
8	8A-NS6-604-010		SPKR,W 200				
9	8A-NS0-604-010		SPKR,M 120				
10	88-NSK-610-010		SPKR,CERAMIC ASSY				

ACCESSORIES / PACKAGE LIST

REF. NO.	PART NO.	KANRI NO.	DESCRIPTION
1	8A-NF6-902-010		IB, LH(ESP)M<80LH, 80HA>
1	8A-NF6-912-010		IB, LH(ESP)M 83<83LH>
1	8A-NF6-903-010		IB, U(ESF)M<80U>
2	8Z-NF8-701-210		RC UNIT, RC-ZAS01
3	87-006-225-010		AM LOOP ANT NC2
4	87-043-115-010		ANT, FEEDER FM
△ 5	87-A91-017-010		PLUG, CONVERSION JT-0476<80LH, 83LH>

アイワ株式会社 〒110-8710 東京都台東区池之端1-2-11 ☎03(3827)3111 (代表)
AIWA CO.,LTD. 2-11, IKENOHATA 1-CHOME, TAITO-KU, TOKYO 110, JAPAN TEL:03 (3827) 3111

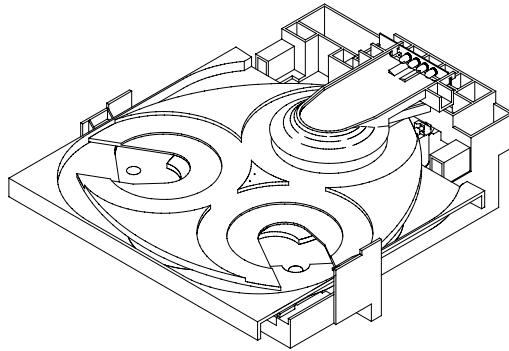

SERVICE MANUAL

CD-R/RW MECHANISM

BASIC CD MECHANISM:KSM-880CAB

TYPE
ZD8RD
YZD8RMDJM
ZD8RMDJM
ZD8RDNDM
YKZD8RDF
ZD8RDM
YZD8RDM
ZD8RN1DM
YZD8RDJM

PROTECTION OF EYES FROM LASER BEAM DURING SERVICING

This set employs laser. Therefore, be sure to follow carefully the instructions below when servicing.

WARNING!

WHEN SERVICING, DO NOT APPROACH THE LASER EXIT WITH THE EYE TOO CLOSELY. IN CASE IT IS NECESSARY TO CONFIRM LASER BEAM EMISSION. BE SURE TO OBSERVE FROM A DISTANCE OF MORE THAN 30cm FROM THE SURFACE OF THE OBJECTIVE LENS ON THE OPTICAL PICK-UP BLOCK.

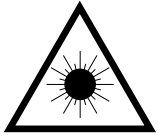

- Caution: Invisible laser radiation when open and interlocks defeated avoid exposure to beam.
- Advarsel: Usynlig laserstråling ved åbning, når sikkerhedsafbrydere er ude af funktion. Undgå udsættelse for stråling.

VAROITUS!

Laiteen Käyttäminen muulla kuin tässä käyttöohjeessa mainitulla tavalla saattaa altistaa käyttäjän turvallisuusluokan 1 ylittävälle näkymättömälle lasersäteilylle.

WARNING!

Om apparaten används på annat sätt än vad som specificeras i denna bruksanvisning, kan användaren utsättas för osynlig laserstråling, som överskrider gränsen för laserklass 1.

CAUTION

Use of controls or adjustments or performance of procedures other than those specified herein may result in hazardous radiation exposure.

ATTENTION

L'utilisation de commandes, réglages ou procédures autres que ceux spécifiés peut entraîner une dangereuse exposition aux radiations.

ADVARSEL!

Usynlig laserstråling ved åbning, når sikkerhedsafbrydere er ude af funktion. Undgå udsættelse for stråling.

This Compact Disc player is classified as a CLASS 1 LASER product.

The CLASS 1 LASER PRODUCT label is located on the rear exterior.

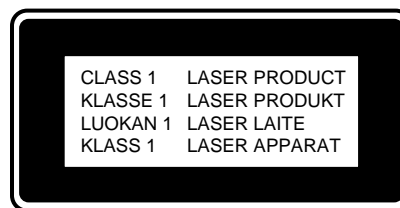

Precaution to replace Optical block

Body or clothes electrostatic potential could ruin laser diode in the optical block. Be sure ground body and workbench, and use care the clothes do not touch the diode.

- 1) After the connection, remove solder shown in the figure below.

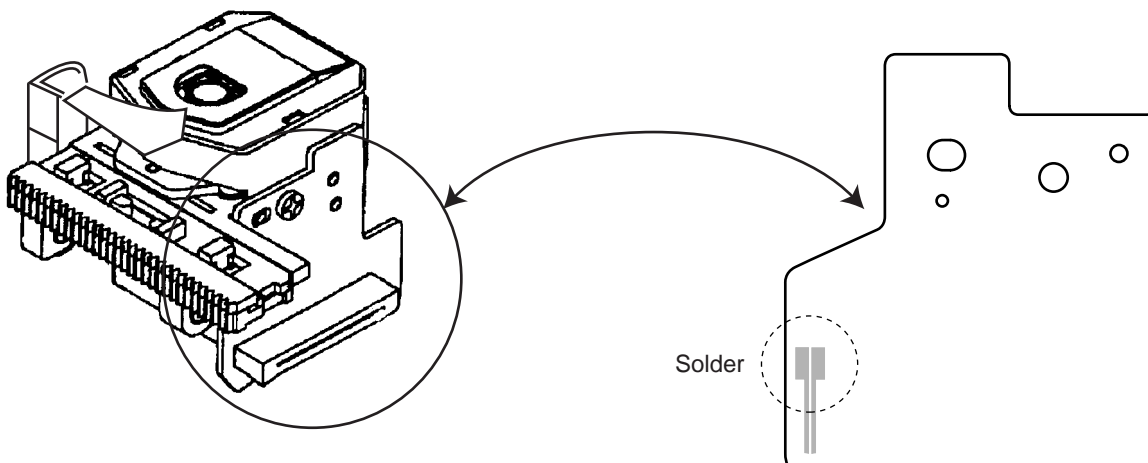

How to Adjust the Rotating Phase of the Gear, Main Cam

- 1) Push down the hooking catch of the CHAS. MECH, and remove the TRAY.
- 2) Align the arrow mark of the Gear, Main Cam with the black round mark of the CHAS, MECHA as shown below.
- 3) Confirm that the Slide, Mech Cam is located in the right position, then insert the TRAY gently.

Caution: If the rotating phase of the Gear, Main Cam is incorrectly adjusted, the chucking operation and tray movement will have malfunction.

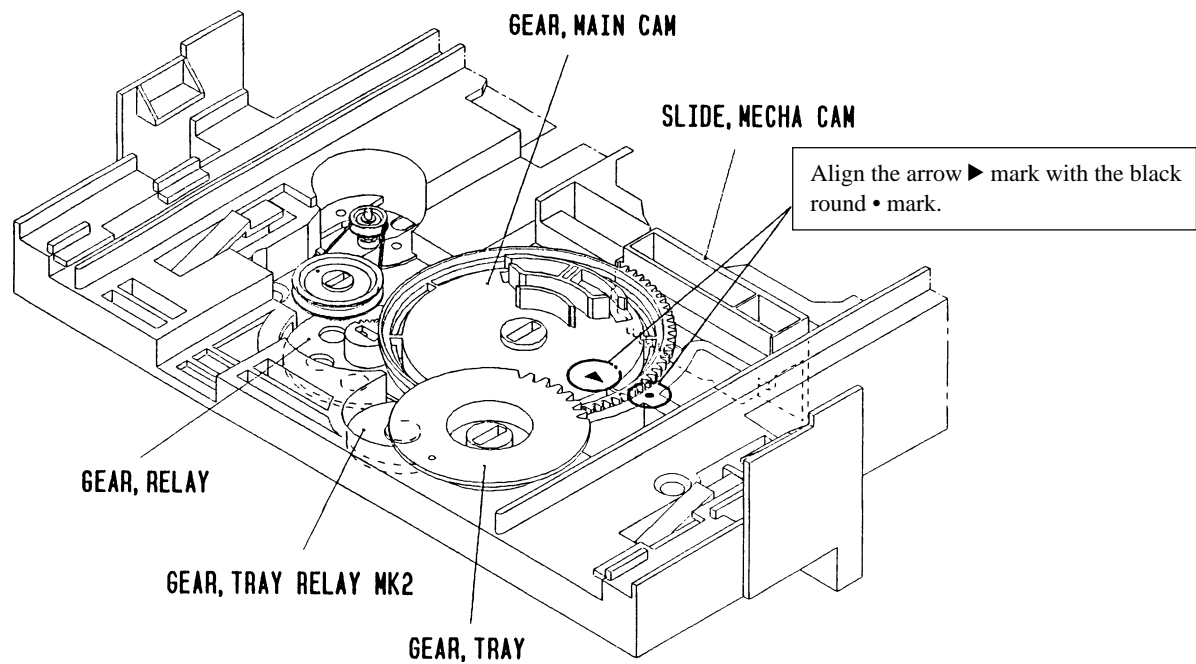

ELECTRICAL MAIN PARTS LIST

DESCRIPTIONで判断できない物は "REFERENCE NAME LIST" を参照してください。
 If can't understand for Description please kindly refer to "REFERENCE NAME LIST".

REF. NO	PART NO.	KANRI NO.	DESCRIPTION	REF. NO	PART NO.	KANRI NO.	DESCRIPTION
IC				C109	87-010-992-080		C-CAP,S 0.047-25 B
	87-A21-381-040	C-IC,LA9235M		C110	87-010-196-080		CHIP CAPACITOR,0.1-25 <YKZD88RDF,ZD8RD>
	87-A21-556-010	C-IC,LC78641E		C110	87-010-196-020		CHIP CAPACITOR,0.1-25 <EXCEPT YKZD88RDF,ZD8RD>
	87-A21-414-010	IC,BA5927S		C111	87-010-260-080		CAP, ELECT 47-25V
				C112	87-010-197-020		CHIP CAPACITOR,0.01-25 <EXCEPT YKZD88RDF,ZD8RD>
TRANSISTOR				C112	87-010-197-080		CHIP CAPACITOR,0.01-25 <YKZD88RDF,ZD8RD>
	87-026-609-080	TR,KTA1266GR		C114	87-010-260-080		CAP, ELECT 47-25V
	87-A30-076-080	C-TR,2SC3052F		C115	87-010-197-080		CHIP CAPACITOR,0.01-25 <YKZD88RDF,ZD8RD>
	87-A30-497-080	TR,2SA1980Y/G		C115	87-010-197-020		CHIP CAPACITOR,0.01-25 <EXCEPT YKZD88RDF,ZD8RD>
	87-A30-087-080	C-FET,2SK2158		C116	87-010-260-080		CAP, ELECT 47-25V
	87-026-237-080	CHIP-TR,DTC124XK <EXCEPT ZD8RN1DM,YZD8RDM>		C117	87-010-197-080		CHIP CAPACITOR,0.01-25 <YKZD88RDF,ZD8RD>
	87-A30-075-080	C-TR,2SA1235F		C117	87-010-197-020		CHIP CAPACITOR,0.01-25 <EXCEPT YKZD88RDF,ZD8RD>
DIODE				C118	87-010-260-080		CAP, ELECT 47-25V
	87-A40-270-080	C-DIODE,MC2838		C119	87-015-819-080		
	87-070-136-080	ZENER,MTZJ5.1B		C120	87-010-312-080		C-CAP,S 15P-50 CH <YKZD88RDF,ZD8RD>
	87-A40-003-080	ZENER,MTZJ4.3A		C120	87-010-312-020		C-CAP,S 15P-50 CH <EXCEPT YKZD88RDF,ZD8RD>
	87-A40-337-080	ZENER,MTZJ6.8B		C121	87-010-312-020		C-CAP,S 15P-50 CH <EXCEPT YKZD88RDF,ZD8RD>
	87-A40-313-080	C-DIODE,MC2840		C121	87-010-312-080		C-CAP,S 15P-50 CH <YKZD88RDF,ZD8RD>
3CD C.B				C122	87-010-404-080		CAP, ELECT 4.7-50V
C1	87-010-374-080	CAP,E 47-10		C123	87-010-197-020		CHIP CAPACITOR,0.01-25 <YKZD88RDF,ZD8RD>
C2	87-010-196-020	CHIP CAPACITOR,0.1-25 <EXCEPT YKZD88RDF,ZD8RD>		C124	87-010-401-080		CAP, ELECT 1-50V
C2	87-010-196-080	CHIP CAPACITOR,0.1-25 <YKZD88RDF,ZD8RD>		C126	87-010-196-020		CHIP CAPACITOR,0.1-25 <EXCEPT YKZD88RDF,ZD8RD>
C3	87-010-260-080	CAP, ELECT 47-25V		C126	87-010-196-080		CHIP CAPACITOR,0.1-25 <YKZD88RDF,ZD8RD>
C4	87-010-260-080	CAP, ELECT 47-25V		C128	87-010-196-020		CHIP CAPACITOR,0.1-25 <EXCEPT YKZD88RDF,ZD8RD>
C5	87-010-197-020	CHIP CAPACITOR,0.01-25 <EXCEPT YKZD88RDF,ZD8RD>		C130	87-010-196-080		CHIP CAPACITOR,0.1-25 <YKZD88RDF,ZD8RD>
C5	87-010-197-080	CHIP CAPACITOR,0.01-25 <YKZD88RDF,ZD8RD>		C130	87-010-196-020		CHIP CAPACITOR,0.1-25 <EXCEPT YKZD88RDF,ZD8RD>
C6	87-010-405-080	CAP, ELECT 10-50V		C132	87-010-405-080		CAP, ELECT 10-50V
C7	87-010-263-080	CAP, ELECT 100-10V		C133	87-010-314-020		C-CAP,S 22P-50V <EXCEPT YKZD88RDF,ZD8RD>
C8	87-012-349-080	C-CAP,S 1000P-50 CH		C133	87-010-314-080		C-CAP,S 22P-50V<YKZD88RDF,ZD8RD>
C10	87-010-546-080	CAP,E 0.33-50		C135	87-A11-088-080		CAP,TC U 100P-50 J CH
C11	87-010-401-080	CAP, ELECT 1-50V		C151	87-010-405-080		CAP, ELECT 10-50V
C13	87-010-321-020	C-CAP,S 82P-50 CH <EXCEPT YKZD88RDF,ZD8RD>		C152	87-010-405-080		CAP, ELECT 10-50V
C13	87-010-321-080	C-CAP,S 82P-50 J CH <YKZD88RDF,ZD8RD>		C192	87-012-349-080		C-CAP,S 1000P-50 CH
C15	87-010-197-020	CHIP CAPACITOR,0.01-25 <EXCEPT YKZD88RDF,ZD8RD>		C193	87-010-196-080		CHIP CAPACITOR,0.1-25 <YKZD88RDF,ZD8RD>
C15	87-010-197-080	CHIP CAPACITOR,0.01-25 <YKZD88RDF,ZD8RD>		C193	87-010-196-020		CHIP CAPACITOR,0.1-25 <EXCEPT YKZD88RDF,ZD8RD>
C16	87-010-260-080	CAP, ELECT 47-25V		C201	87-A10-730-080		CAP,E 1000-16 SMG
C101	87-010-992-080	C-CAP,S 0.047-25 B		C202	87-010-196-080		CHIP CAPACITOR,0.1-25 <YKZD88RDF,ZD8RD>
C102	87-010-401-080	CAP, ELECT 1-50V		C202	87-010-196-020		CHIP CAPACITOR,0.1-25 <EXCEPT YKZD88RDF,ZD8RD>
C103	87-010-196-020	CHIP CAPACITOR,0.1-25 <EXCEPT YKZD88RDF,ZD8RD>		C204	87-010-196-020		CHIP CAPACITOR,0.1-25 <EXCEPT YKZD88RDF,ZD8RD>
C103	87-010-196-080	CHIP CAPACITOR,0.1-25 <YKZD88RDF,ZD8RD>		C204	87-010-196-080		CHIP CAPACITOR,0.1-25 <EXCEPT YKZD88RDF,ZD8RD>
C104	87-010-196-020	CHIP CAPACITOR,0.1-25 <EXCEPT YKZD88RDF,ZD8RD>		C205	87-010-405-080		CAP, ELECT 10-50V
C104	87-010-196-080	CHIP CAPACITOR,0.1-25 <YKZD88RDF,ZD8RD>		C206	87-010-405-080		CAP, ELECT 10-50V
C105	87-010-260-080	CAP, ELECT 47-25V		C207	87-010-196-020		CHIP CAPACITOR,0.1-25 <EXCEPT YKZD88RDF,ZD8RD>
C106	87-010-322-020	C-CAP,S 100P-50 CH <EXCEPT YKZD88RDF,ZD8RD>					
C106	87-010-322-080	C-CAP,S 100P-50 CH <YKZD88RDF,ZD8RD>					
C107	87-010-196-020	CHIP CAPACITOR,0.1-25 <EXCEPT YKZD88RDF,ZD8RD>					
C107	87-010-196-080	CHIP CAPACITOR,0.1-25 <YKZD88RDF,ZD8RD>					
C108	87-010-186-080	CAP,CHIP 4700P<YKZD88RDF,ZD8RD>					
C108	87-010-186-020	CAP,CHIP 4700P <EXCEPT YKZD88RDF,ZD8RD>					

REF. NO	PART NO.	KANRI NO.	DESCRIPTION	REF. NO	PART NO.	KANRI NO.	DESCRIPTION
C207	87-010-196-080		CHIP CAPACITOR,0.1-25 <YKZD88RDF,ZD8RD>	CN202	87-A60-130-010		CONN,5P V
C301	87-010-382-080		CAP, ELECT 22-25V	CN501	84-ZG1-647-010		CONN ASSY,2P <EXCEPT ZD8RN1DM,ZD8RNDM>
C302	87-010-196-020		CHIP CAPACITOR,0.1-25 <EXCEPT YKZD88RDF,ZD8RD>	CN601	87-009-345-010		CONN,2P PH V <EXCEPT ZD8RN1DM,ZD8RDM,YZD8RDM,ZD8RNDM>
C302	87-010-196-080		CHIP CAPACITOR,0.1-25 <YKZD88RDF,ZD8RD>	CON401	87-099-030-010		CONN,13P 6216H
C303	87-010-260-080		CAP, ELECT 47-25V	FB601	87-008-372-080		FLTR,EMI BL01 RN1 <EXCEPT ZD8RN1DM,ZD8RDM,YZD8RDM,ZD8RNDM>
C401	87-010-322-020		C-CAP,S 100P-50 CH <EXCEPT YKZD88RDF,ZD8RD>	FB602	87-008-372-080		FLTR,EMI BL01 RN1
C401	87-010-322-080		C-CAP,S 100P-50 CH <YKZD88RDF,ZD8RD>	LED601	87-A40-558-010		LED,SLZ-8128A-01-A
C402	87-010-322-020		C-CAP,S 100P-50 CH <EXCEPT YKZD88RDF,ZD8RD>	M201	87-045-305-010		MOTOR, RF-500TB DC-5V (2MA)
C402	87-010-322-080		C-CAP,S 100P-50 CH <YKZD88RDF,ZD8RD>	SW201	87-036-109-010		SW,MICRO SPPB61
C402	87-010-322-080		C-CAP,S 100P-50 CH <EXCEPT YKZD88RDF,ZD8RD>	SW202	87-036-109-010		SW,MICRO SPPB61
C403	87-010-322-020		C-CAP,S 100P-50 CH <EXCEPT YKZD88RDF,ZD8RD>	X101	87-A70-046-010		VIB,XTAL 16.934MHZ
C403	87-010-322-080		C-CAP,S 100P-50 CH <YKZD88RDF,ZD8RD>	LED. C.B			
C404	87-010-322-080		C-CAP,S 100P-50 CH <YKZD88RDF,ZD8RD>	LED501	87-A40-263-080		LED,SLH-56PCT31 GRN <EXCEPT ZD8RN1DM,ZD8RNDM>
C404	87-010-322-020		C-CAP,S 100P-50 CH <EXCEPT YKZD88RDF,ZD8RD>	LED502	87-A40-263-080		LED,SLH-56PCT31 GRN <EXCEPT ZD8RN1DM,ZD8RNDM>
C404	87-010-322-020		C-CAP,S 100P-50 CH <EXCEPT YKZD88RDF,ZD8RD>	LED503	87-A40-268-080		LED,SLH-56DCT31 ORN <EXCEPT ZD8RN1DM,ZD8RNDM>
C405	87-010-322-020		C-CAP,S 100P-50 CH <EXCEPT YKZD88RDF,ZD8RD>	LED504	87-A40-268-080		LED,SLH-56DCT31 ORN <EXCEPT ZD8RN1DM,ZD8RNDM>
C405	87-010-322-080		C-CAP,S 100P-50 CH <YKZD88RDF,ZD8RD>	T-T C.B			
C406	87-010-322-020		C-CAP,S 100P-50 CH <EXCEPT YKZD88RDF,ZD8RD>	C401	87-018-214-080		CAP TC U 0.1-50F
C406	87-010-322-080		C-CAP,S 100P-50 CH <YKZD88RDF,ZD8RD>	CON401	86-NFZ-675-010		CONN,5P H 6216-11H
C407	87-010-405-080		CAP, ELECT 10-50V	M401	87-045-364-010		MOTOR(BCH3B14)
C454	87-010-196-020		CHIP CAPACITOR,0.1-25 <EXCEPT YKZD88RDF,ZD8RD>	PS401	87-026-573-010		SNSR,PHOTO GP1S53V
C454	87-010-196-080		CHIP CAPACITOR,0.1-25 <YKZD88RDF,ZD8RD>	MOTOR C.B			
C601	87-010-260-080		CAP, ELECT 47-25V	PIN3	91-564-722-110		CONN,PIN 6P
C602	87-010-196-080		CHIP CAPACITOR,0.1-25 <YKZD88RDF,ZD8RD>	SW1	91-572-085-110		LEAF SWITCH
C602	87-010-196-020		CHIP CAPACITOR,0.1-25 <EXCEPT YKZD88RDF,ZD8RD>				
CN1	87-A60-429-010		CONN,16P H TOC-A				
CN201	84-ZG1-648-010		CONN ASSY,6P				

- Regarding connectors, they are not stocked as they are not the initial order items.
The connectors are available after they are supplied from connector manufacturers upon the order is received.

○チップ抵抗部品コード/CHIP RESISTOR PART CODE

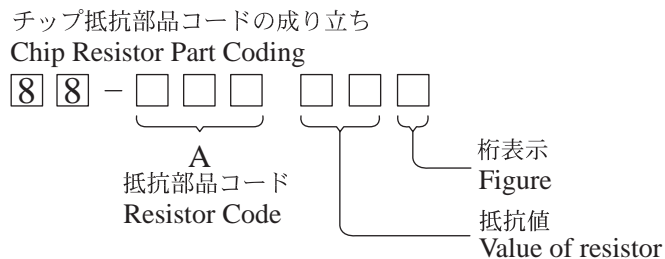

チップ抵抗
Chip resistor

容量 Wattage	種類 Type	許容誤差 Tolerance	記号 Symbol	寸法/Dimensions (mm)			抵抗コード : A Resistor Code : A	
				外形/Form	L	W		t
1/16W	1005	± 5%	CJ		1.0	0.5	0.35	104
1/16W	1608	± 5%	CJ		1.6	0.8	0.45	108
1/10W	2125	± 5%	CJ		2	1.25	0.45	118
1/8W	3216	± 5%	CJ		3.2	1.6	0.55	128

TRANSISTOR ILLUSTRATION

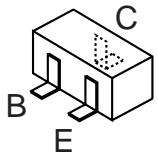

2SA1235F
2SC3052F
DTC124XK



2SA1980Y/G
KTA1266GR

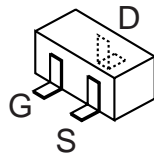

2SK2158

BLOCK DIAGRAM

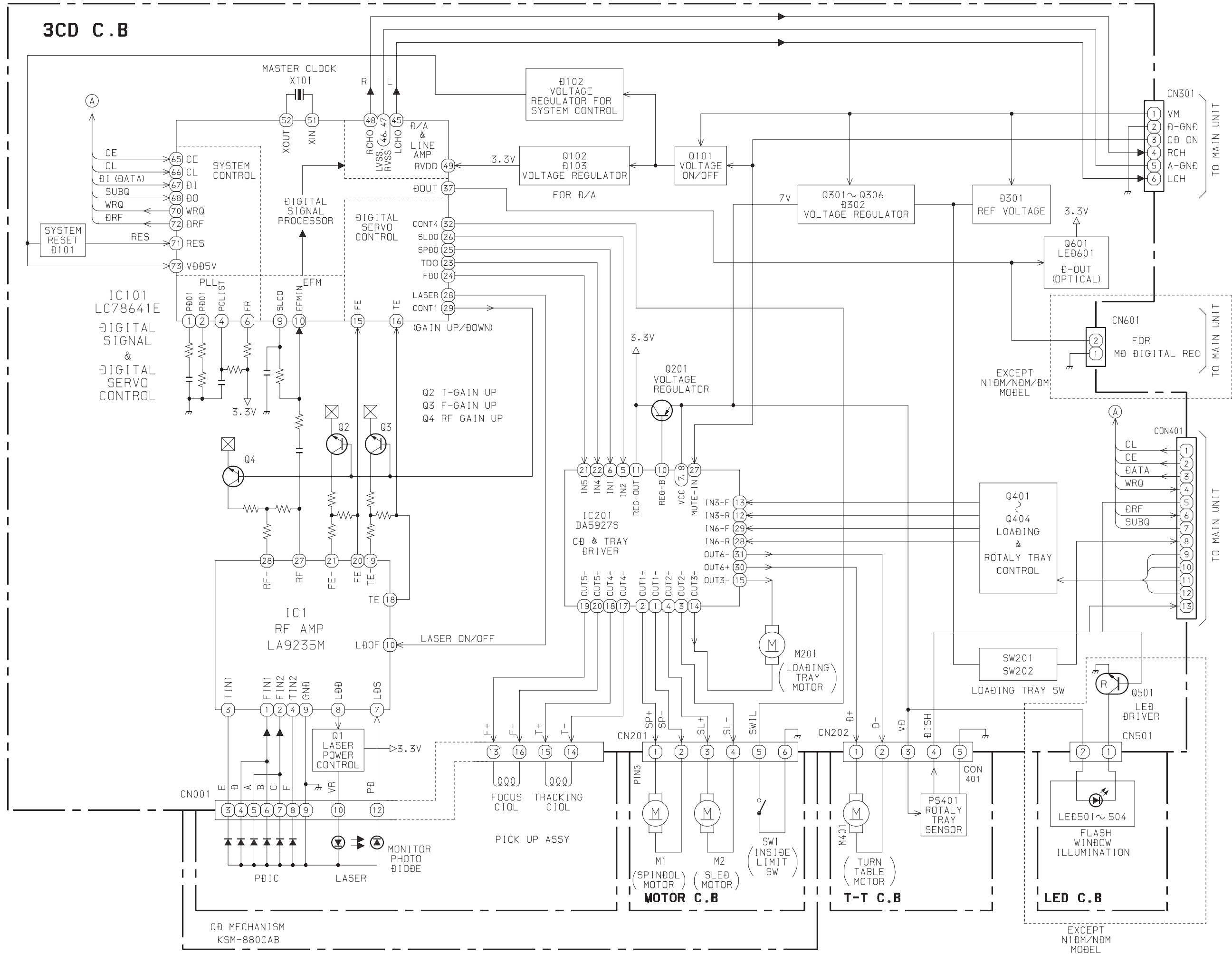

WIRING

1 2 3 4 5 6 7 8 9 10 11 12 13 14

A
B
C
D
E
F
G
H
I
J
K

T-T C.B

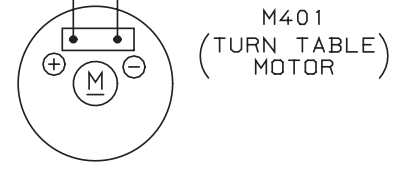
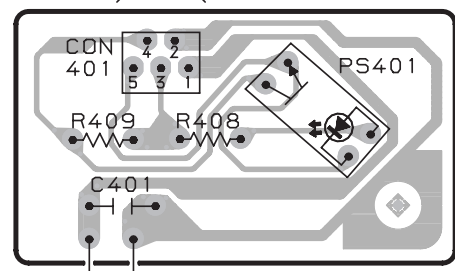

MOTOR C.B

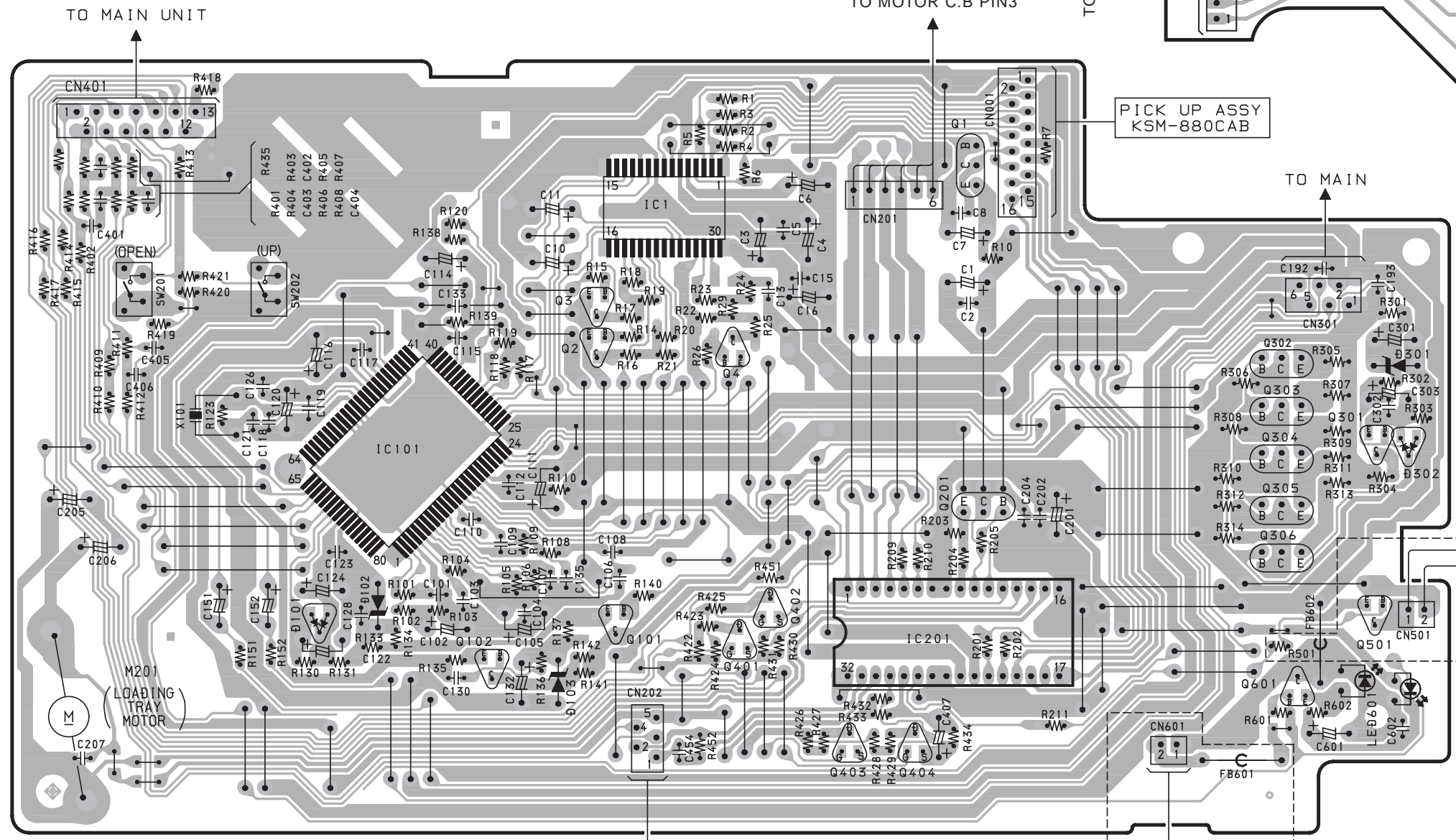
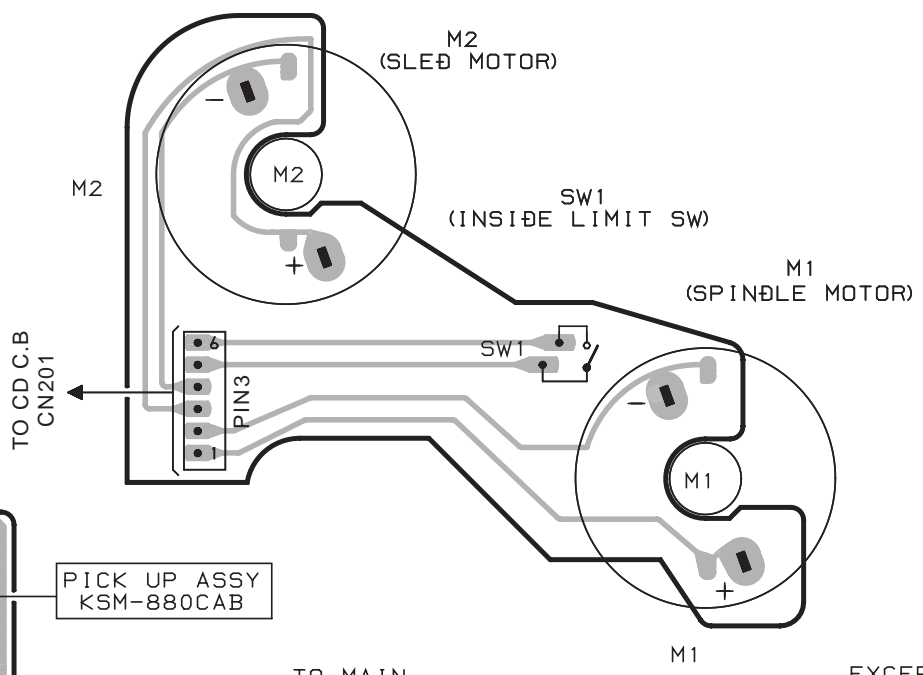

EXCEPT N1ØM/NØM MODEL

LED C.B

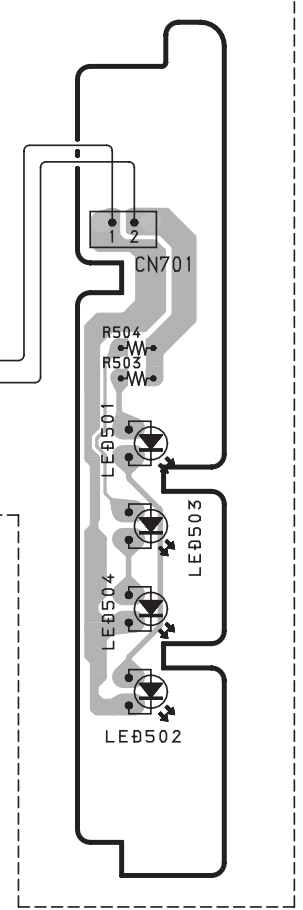

3CØ C.B

Q601, LED601
DIGITAL OUT
(OPTICAL)

TO MAIN UNIT
EXCEPT N1ØM/NØM/ØM MODEL

SCHEMATIC DIAGRAM

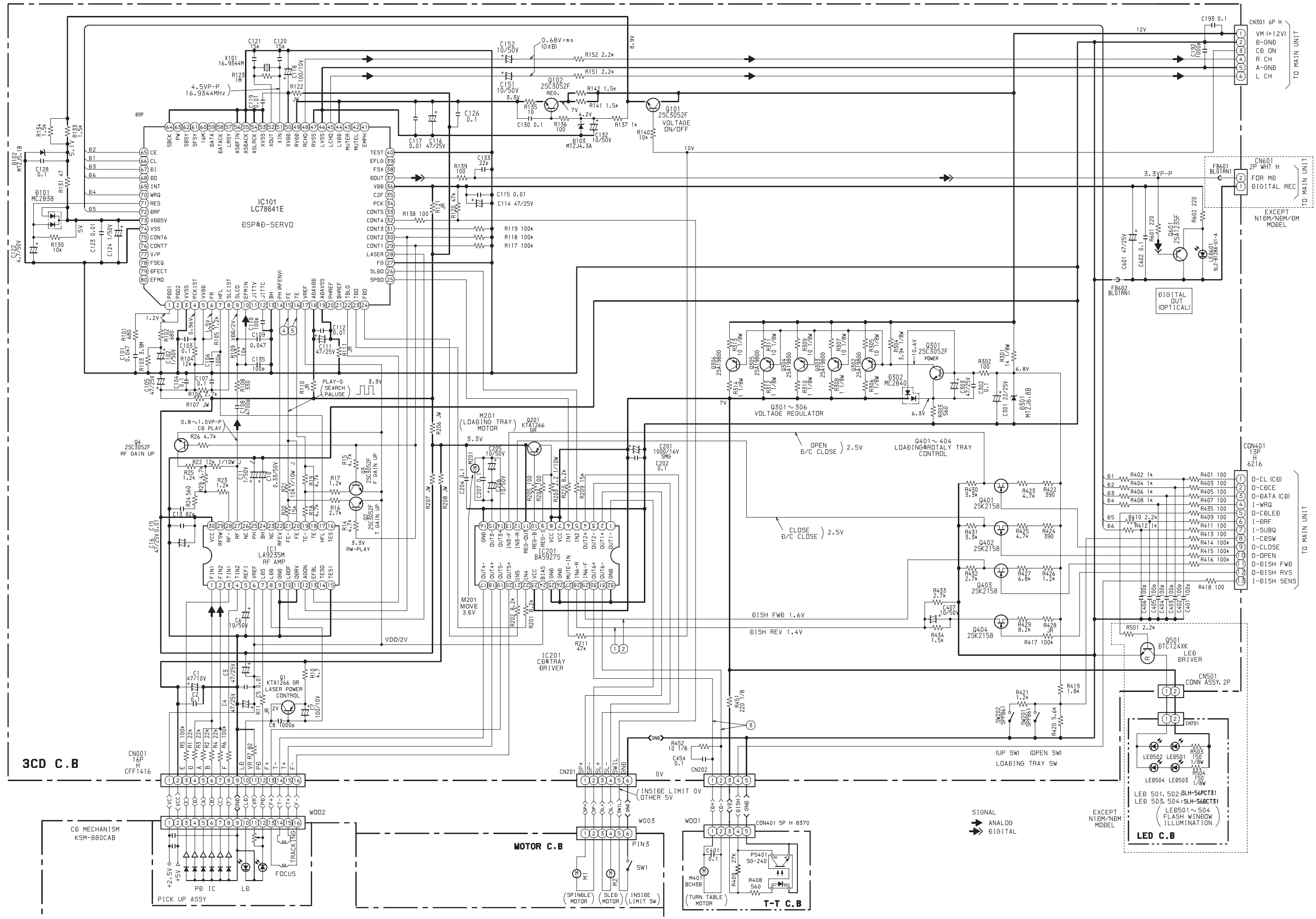

TEST MODE

1. How to Start the CD Test Mode

While pressing the CD function key, connect the AC power plug to wall outlet.
The test mode starts up and “CD TEST” appears on the display.

2. How to Exit the CD Test Mode

Press the POWER button or disconnect the AC power plug from wall outlet.

* When any function key other than PLAY is pressed during playback, the test mode is canceled.

3. Function and Use of the CD Test Mode

NO	MODE	How to enter the mode	Display	Operation	Check item
1	Start mode		All indicators turn on	• All FL all indicators turn on	• FL check • Microprocessor check
2	Search mode	STOP button	CD	• LD turns on all the time • Focus search continuous operation *1 • Spindle motor continuous kick	• APC circuit check • Laser current measurement • Focus search waveform check • Focus error waveform check (Ignores DRF during search mode)
3	Play mode	PLAY button	Normal	• Normal playback • Focus search is continued if failed in TOC READ.	• Each servo circuit is checked • DRF check
4	Traverse mode	PAUSE button	Normal	• Tracking servo OFF/ON Repeats OFF/ON every time the PAUSE button is pressed	• Tracking balance check
5	Sled mode	FF button	CD TEST	• Moves PU to inner circumference *2 Kicks the lens to inner circumference at the same time	• Sled circuit check • Tracking circuit check • Mechanism operation check • PU check
		RWD button	CD TEST	• Moves PU to outer circumference *2 Kicks the lens to outer circumference at the same time	
6	Spindle mode	TAPE REC button	All indicators turn on	• Pressing the button once rotates the spindle motor in the normal direction (rough speed). Pressing the button again rotates it in the reverse direction. Pressing it again stops the motor	• Spindle circuit check • Spindle motor check
7	RF AGC mode	TUNER button	AGC ON/OFF	• Repeats ON/OFF every time the TUNER button is pressed	• PU good or defective check • RF AMP circuit check

*1 When the focus search keeps running for 10 minutes or longer continuously, the driver IC heats up, and the protective circuit works so that the machine may stop operating.

In this case, turn off the main power, wait for a while and restart the machine.

*2 Do not keep pressing the FF or RWD button while the pickup is located at the innermost or outermost circumference because the gear can be damaged as the sled motor keeps rotating.

4. Automatic Adjustment Result Display

The automatic adjustment values of the focus and the tracking can be displayed.

4-1. Automatic Adjustment Result Display of Focus Offset Cancel/Gain

- 1) Enter the start mode (all indicators turn on).
- 2) Press the TAPE button to display “F**” and set each of the adjustment item to either ON or OFF. (Refer to the following table.)
- 3) Press the PLAY button to play back the CD.
- 4) Press the CD button.
- 5) The automatic adjustment value “F** **” is displayed. (Refer to the following table.)
- 6) Upon completion of check, press the CD button twice to return to the play mode.

Adjustment item (ON = 1, OFF = 0)			Automatic adjustment value display (Asterisk * means hexadecimal display.)			
F	OFFSET	GAIN	F	OFFSET	—	GAIN
F	0	0	F	Not displayed	Not displayed	Not displayed
F	1	1	F	**	Not displayed	**
F	1	0	F	**	Not displayed	Not displayed
F	0	1	F	Not displayed	Not displayed	**

4-2. Automatic Adjustment Result Display of Tracking Offset Cancel/Balance/Gain

- 1) Enter the start mode (all indicators turn on).
- 2) Press the AUX button to display “T****” and set each adjustment item to either ON or OFF. (Refer to the following table.)
- 3) Press the PLAY button to play back the CD.
- 4) Press the CD button twice.
- 5) The automatic adjustment value “F*****” is displayed. (Refer to the following table.)
- 6) Upon completion of check, press the CD button to return to the play mode.

Adjustment item (ON = 1, OFF = 0)				Automatic adjustment value display (Asterisk * means hexadecimal display.)			
T	OFFSET	BALANCE	GAIN	T	OFFSET	BALANCE	GAIN
T	0	0	0	T	Not displayed	Not displayed	Not displayed
T	1	1	1	T	**	**	**
T	1	1	0	T	**	**	Not displayed
T	1	0	1	T	**	Not displayed	**
T	1	0	0	T	**	Not displayed	Not displayed
T	0	1	1	T	Not displayed	**	**
T	0	1	0	T	Not displayed	**	Not displayed
T	0	0	1	T	Not displayed	Not displayed	**

WAVE FORM

- ① IC201 ⑳ (IN6-R) VOLT/DIV: 500mV
TIME/DIV: 200mS

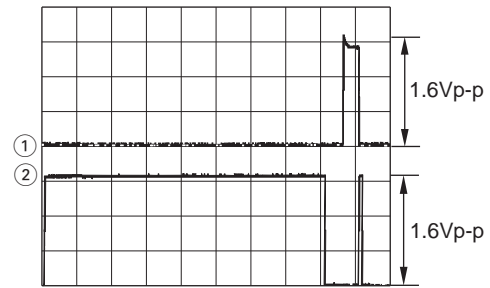

- ③ Between CN202 ① and ② (② Pin: 0 Level) VOLT/DIV: 1V
TIME/DIV: 200mS

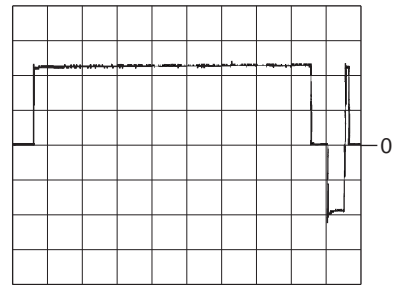

- ④ IC101 ⑮ (FE) VOLT/DIV: 500mV
TIME/DIV: 2mS

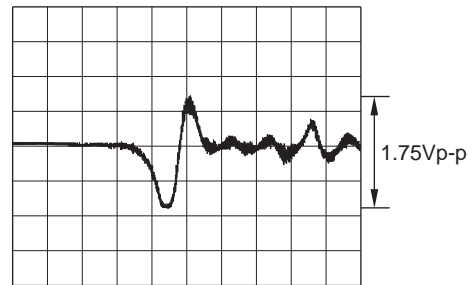

- ⑤ IC101 ⑯ (TE) VOLT/DIV: 200mV
TIME/DIV: 200μS

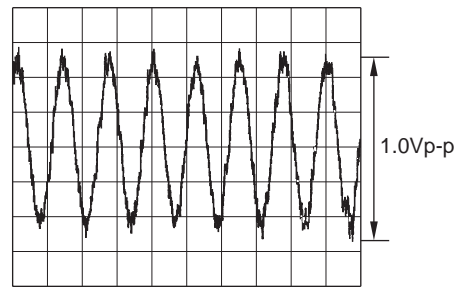

IC BLOCK DIAGRAM

IC, BA5927S

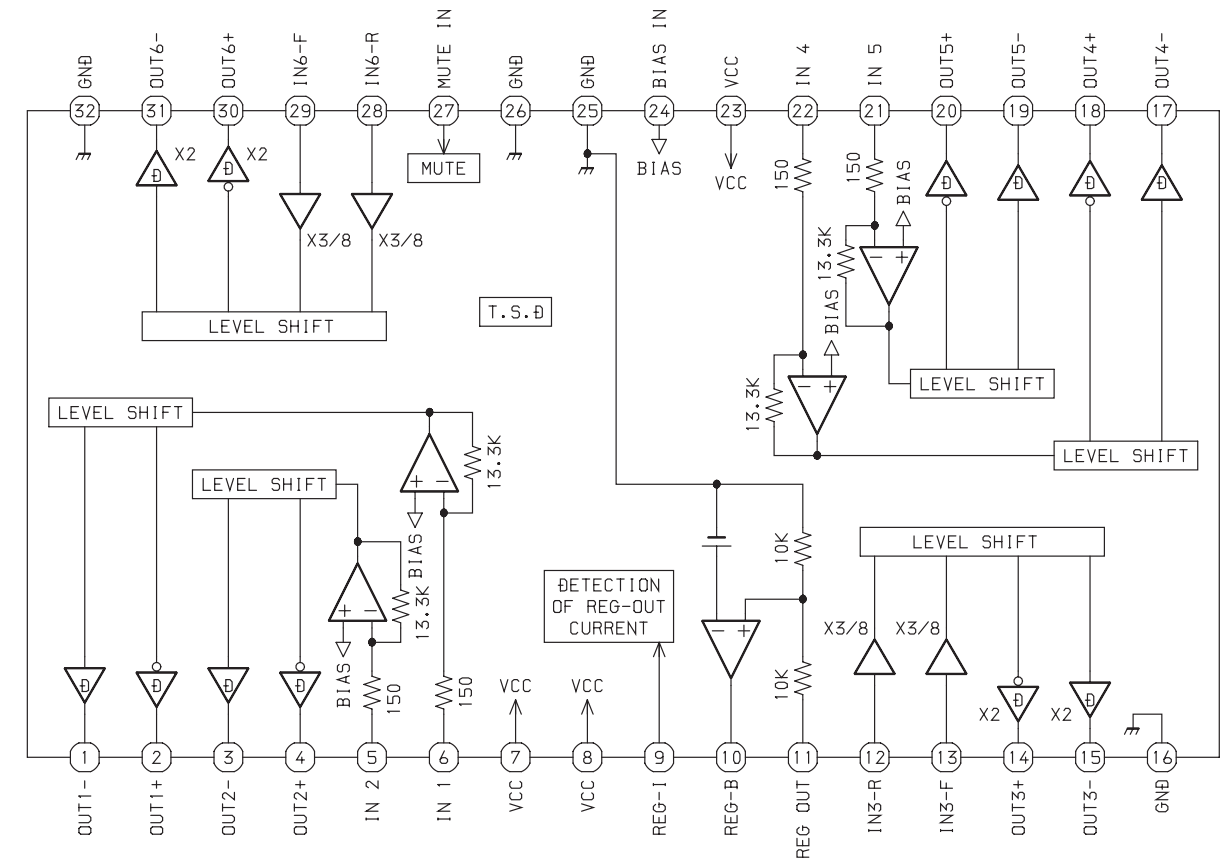

IC, LA9235M

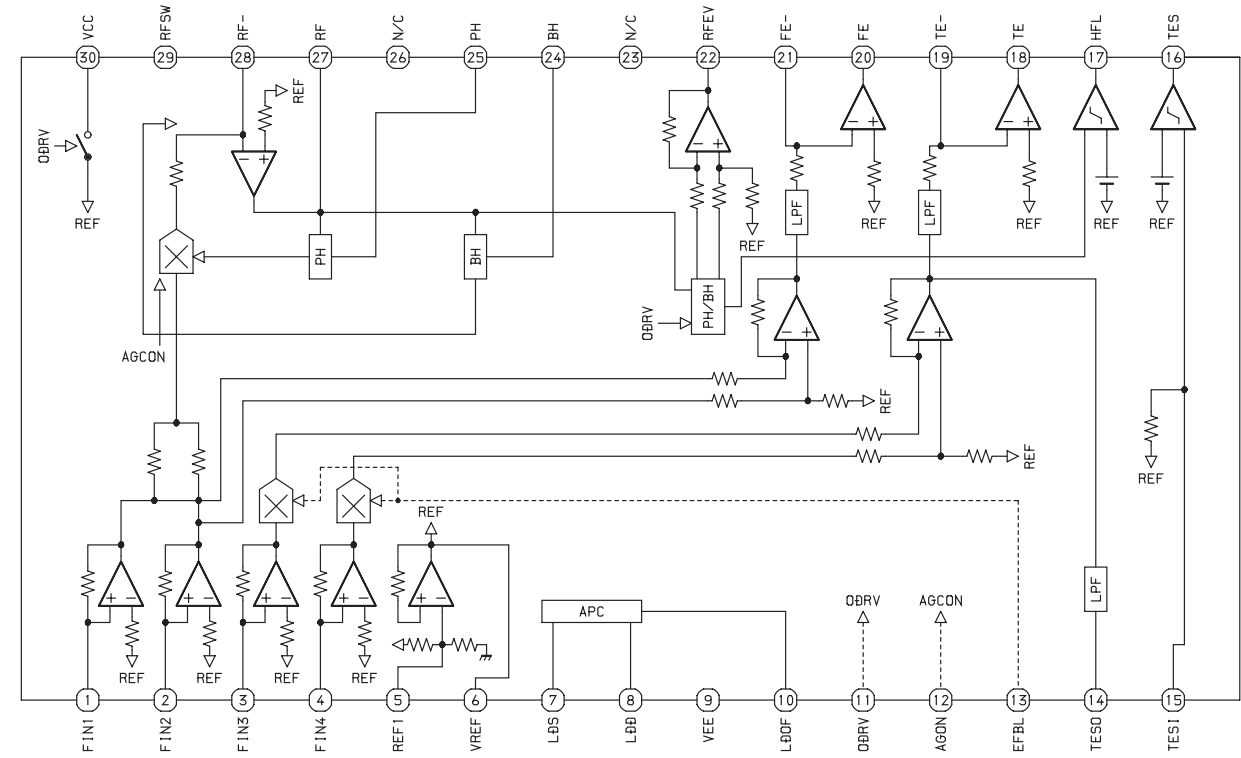

IC DESCRIPTION

IC, LC78641E

Pin No.	Pin Name	I/O	Description
1	PDO1	O	Internal VCO control phase comparator output pin. (Pull down)
2	PDO2	O	Internal VCO control phase comparator output pin. OFF for rough servo, ON for phase servo. (Pull down)
3	VVSS	—	Internal VCO ground pin.
4	PCKIST	—	PDO output current adjustment resistor connection pin.
5	VVDD	—	Internal VCO power supply pin.
6	FR	—	VCO frequency range adjustment resistor connection pin. (Pull up)
7	HFL	I	Mirror detection signal input pin.
8	SLCIST	—	SLCO output current adjustment resistor connection pin.
9	SLCO	O	Control output.
10	EFMIN	I	EFM signal input pin.
11	JITTV	O	Jitter detection monitor pin.
12	JITTC	O	Jitter detection adjustment pin. (Pull down)
13	BH	I	BH signal input pin. (Connected to GND)
14	PH (RFENV)	I	PH signal or RFENV signal input pin.
15	FE	I	FE signal input pin.
16	TE	I	TE signal input pin.
17	VREF	I	VREF input pin.
18	ADAVDD	—	Servo A/D, D/A power supply pin.
19	ADAVSS	—	Servo A/D, D/A ground pin.
20	PHREF	O	PH reference output pin. (Not connected)
21	BHREF	O	BH reference output pin. (Not connected)
22	TBLO	O	Tracking balance output pin.
23	TDO	O	Tracking control output pin.
24	FDO	O	Focus control output pin.
25	SPDO	O	Spindle control output pin.
26	SLDO	O	Thread control output pin.
27	DVREF/FG	I/O	Output driver VREF output pin. FG signal input pin. (Connected to GND)
28	LASER	O	Laser ON/OFF control pin.
29	CONT1	I/O	General-purpose input/output pin 1. (Connected to GND)
30	CONT2	I/O	General-purpose input/output pin 2. (Connected to GND)
31	CONT3	I/O	General-purpose input/output pin 3. (Connected to GND)
32	CONT4	I/O	General-purpose input/output pin 4.
33	CONT5	I/O	General-purpose input/output pin 5. (Not connected)
34	PCK	O	EFM data playback clock monitor pin. Average 4.3218MHz when the phase is locked. (Not connected)
35	C2F	O	C2 flag output pin. (Not connected)
36	VDD	—	Digital power supply pin.
37	DOUT	O	Digital out output pin. (EIAJ format)
38	FSX	O	Output pin for the 7.35kHz synchronization signal divided from the crystal oscillator. (Not connected)

Pin No.	Pin Name	I/O	Description
39	EFLG	O	C1, C2 error correction monitor pin. (Not connected)
40	TEST	I	Test input pin. (Connected to GND)
41	EMPH	I/O	Emphasis pin. Which becomes an input pin after reset and can be controlled externally. This becomes an emphasis monitor pin under control by command. (Not connected)
42	MUTEL	O	L channel mute output pin. (Not connected)
43	MUTER	O	R channel mute output pin. (Not connected)
44	LVDD	—	L channel power supply pin.
45	LCHO	O	L channel output pin.
46	LVSS	—	L channel ground pin.
47	RVSS	—	R channel ground pin.
48	RCHO	O	R channel output pin.
49	RVDD	—	R channel power supply pin.
50	XVDD	—	Crystal oscillator power supply pin.
51	XIN	I	Connections for a 16.9344MHz crystal oscillator pin.
52	XOUT	O	
53	XVSS	—	Crystal oscillator ground pin.
54	ASLRCK	I	L/R clock input pin. (Connected to GND)
55	ASDACK	I	Bit clock input pin. (Connected to GND)
56	ASDFIN	I	L/R channel data input pin. (Connected to GND)
57	LRSY	O	L/R clock output pin. (Not connected)
58	DATAACK	O	Bit clock output pin. (Not connected)
59	DATA	O	L/R channel data output pin. (Not connected)
60	16M	O	16.9344MHz output pin. (Not connected)
61	SFSY	O	Subcode frame synchronization signal output pin. This signal falls when the subcode is in the standby state. (Not connected)
62	SBSY	O	Subcode clock synchronization signal output pin. (Not connected)
63	PW	O	Subcode P, Q, R, S, T, U and W output pin. (Not connected)
64	SBCK	I	Subcode readout clock input pin. (Connected to GND)
65	CE	I	Chip enable signal input pin.
66	CL	I	Data transfer clock input pin.
67	DI	I	Data input pin.
68	DO	O	Data output pin.
69	INT	O	Interruption signal output pin. (Not connected)
70	WRQ	O	Interruption signal output pin.
71	RES	I	Reset input pin. This pin must be set low briefly after power is first applied.
72	DRF	O	Focus ON detect pin.
73	VDD5V	—	Microprocessor interface power supply.
74	VSS	—	Digital ground pin.
75	CONT6	I/O	General-purpose input/output pin 6.
76	CONT7	I/O	General-purpose input/output pin 7.
77	V/P	O	Rough servo/phase control automatic switching monitor output pin. “H” for rough servo and “L” for phase servo. (Not connected)

Pin No.	Pin Name	I/O	Description
78	FSEQ	O	Synchronization signal detection output pin. Outputs a high level when the synchronization signal detected from the EFM signal and the internally generated synchronization signal agree. (Not connected)
79	DEFECT	I/O	Defect pin. Which becomes an input pin after reset and can be controlled externally. This becomes the defect monitor pin under control by command. (Not connected)
80	EFMO	O	EFM signal output pin. (Not connected)

MECHANICAL EXPLODED VIEW 1/1

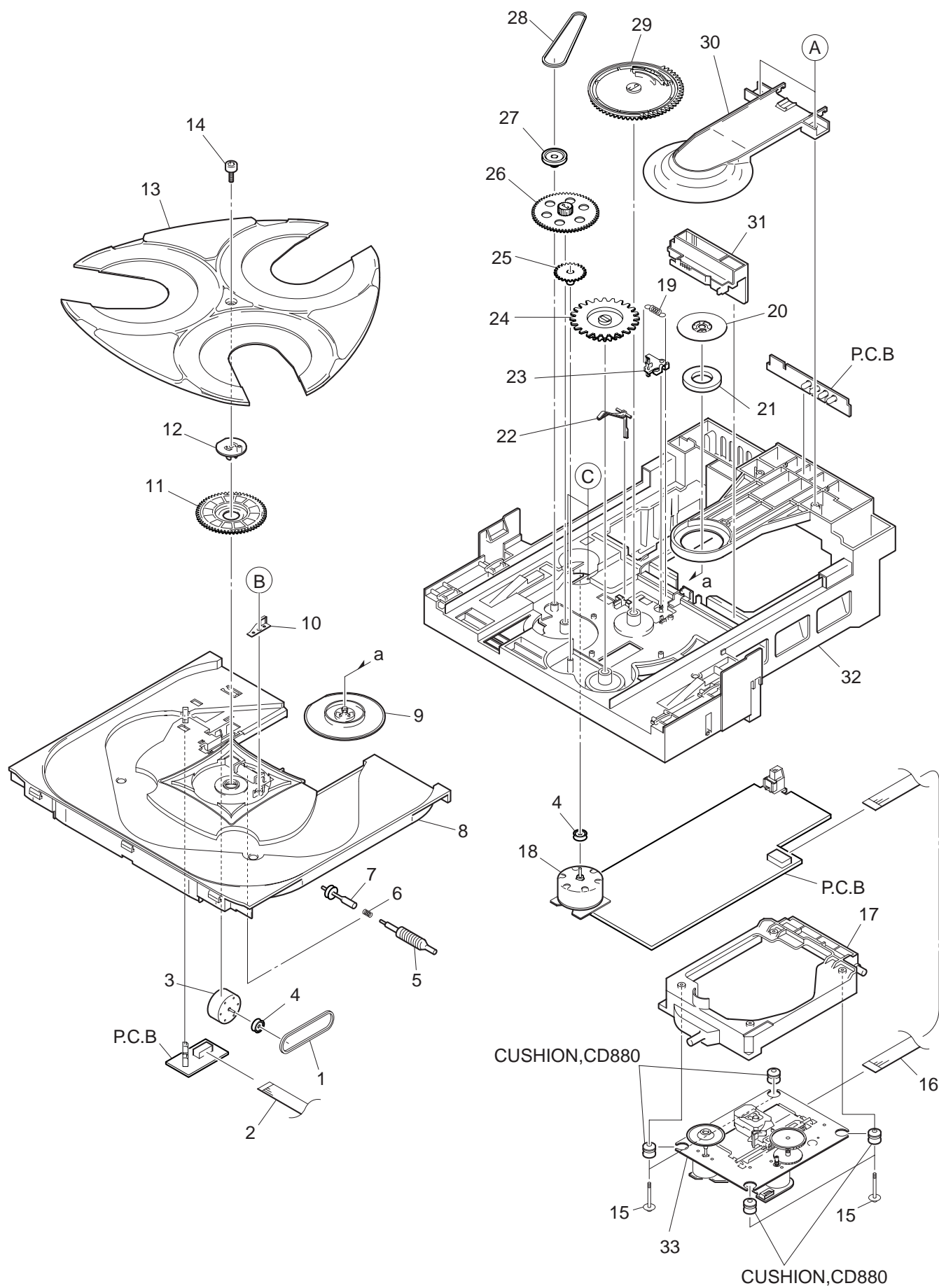

MECHANICAL PARTS LIST 1/1

DESCRIPTIONで判断できない物は "REFERENCE NAME LIST" を参照してください。
 If can't understand for Description please kindly refer to "REFERENCE NAME LIST".

REF. NO	PART NO.	KANRI NO.	DESCRIPTION	REF. NO	PART NO.	KANRI NO.	DESCRIPTION
1	84-ZG1-225-010		BELT,SQ1.0-63.3	20	81-ZG1-255-110		PLATE,MAGNET MK2<EXCEPT ZD8RN1DM>
2	84-ZG1-673-010		F-CABLE,5P 1.25 210MM BLACK N <EXCEPT ZD8RN1DM,ZD8RNDM>	21	83-ZG3-604-010		RING,MAG 2
2	84-ZG1-672-010		F-CABLE,5P 1.25 210MM WHITE N <ZD8RN1DM,ZD8RNDM>	22	83-ZG3-213-010		LVR,SW
3	87-045-364-010		MOTOR(BCH3B14)	23	84-ZG1-208-210		LEVER,CAM<YKZD8RDF>
4	84-ZG1-267-010		PULLEY,LOAD MO 8 <EXCEPT YKZD8RDF,ZD8RD>	23	84-ZG1-266-010		LEVER,CAN 8<EXCEPT YKZD8RDF>
4	81-ZG1-212-010		PULLY,LOAD MO<YKZD8RDF,ZD8RD>	24	84-ZG1-205-210		GEAR,TRAY (*)
5	84-ZG1-238-010		GEAR,WORM N	25	81-ZG1-291-110		GEAR,TRAY RELAY NO3
6	84-ZG1-248-010		SPR-C,WORM	26	84-ZG1-206-110		GEAR,RELAY<YKZD8RDF>
7	84-ZG1-239-210		PULLY,WORM N	26	84-ZG1-274-010		GEAR,RELAY 8<EXCEPT YKZD8RDF>
8	84-ZG1-008-210		TRAY,NO3<ZD8RD>	27	84-ZG1-207-010		PULLEY,RELAY
8	8A-ZG1-001-010		TRAY,NO3 BLU<EXCEPT ZD8RD>	28	84-ZG1-209-010		BELT,SQ1.8-117.7
9	8A-ZG1-210-010		HLDL,MAGNET 23<YKZD8RDF>	29	84-ZG1-203-410		GEAR,MAIN CAM<ZD8RNDM>
9	84-ZG1-243-210		HLDL,MAGNET N(J) <YZD8RDJM,ZD8RMDJM,YZD8RMDJM>	29	84-ZG1-215-410		GEAR,MAIN CAM BLU<EXCEPT ZD8RNDM>
9	84-ZG1-289-010		HLDL,MAGNET NAT<ZD8RNDM>	30	84-ZG1-011-010		REFLECTOR,CD <EXCEPT ZD8RN1DM,ZD8RNDM>
9	81-ZG1-277-310		HLDL,MAGNET N <ZD8RN1DM,ZD8RDM,YZD8RDM,ZD8RD>	31	84-ZG1-216-310		SLIDE,MECHA CAM YEL <EXCEPT ZD8RNDM>
10	84-ZG1-259-010		SPR-P,WORM	31	84-ZG1-204-310		SLIDER,MECHA CAM<ZD8RNDM>
11	84-ZG1-221-010		GEAR,MAIN TT<YKZD8RDF>	32	84-ZG1-286-010		CHAS,MECHA NAT<ZD8RNDM>
11	84-ZG1-269-010		GEAR,MAIN TT 4<EXCEPT YKZD8RDF>	32	84-ZG1-201-410		CHAS,MECHA<EXCEPT ZD8RNDM>
12	84-ZG1-224-010		LEVER,TT<EXCEPT ZD8RNDM>	33	M8-ZZK-C90-070		KSM-880CAB
12	84-ZG1-288-010		LEVER,TT NAT<ZD8RNDM>	A	87-067-703-010		TAPPING SCREW, BVT2+3-10 <EXCEPT ZD8RN1DM,ZD8RNDM>
13	8A-ZG1-002-010		TURN TABLE,NO1 BLU<EXCEPT ZD8RD>	B	87-067-981-010		BVT2+3-6 BLK
13	84-ZG1-005-210		TURNTABLE,NO1(*)<ZD8RD>	C	87-251-070-410		U+2.6-3
14	81-ZG1-239-010		S-SCREW,TT				
15	8A-ZG1-201-010		S-SCREW,MECH 880				
16	85-NFT-611-110		FF-CABLE 16P-1.0				
17	84-ZG1-299-210		HLDL,MECHA NO3<EXCEPT ZD8RNDM>				
17	8A-ZG1-203-010		HLDL,MECHA NO3 NAT<ZD8RNDM>				
18	87-045-305-010		MOTOR, RF-500TB DC-5V (2MA)				
19	84-ZG1-211-010		SPR-E CAM S				
20	84-ZG1-285-010		PLATE,MAGNET BLK<ZD8RN1DM>				

COLOR NAME TABLE

Basic color symbol	Color	Basic color symbol	Color	Basic color symbol	Color
B	Black	C	Cream	D	Orange
G	Green	H	Gray	L	Blue
LT	Transparent Blue	N	Gold	P	Pink
R	Red	S	Silver	ST	Titan Silver
T	Brown	V	Violet	W	White
WT	Transparent White	Y	Yellow	YT	Transparent Yellow
LM	Metallic Blue	LL	Light Blue	GT	Transparent Green
LD	Dark Blue	DT	Transparent Orange		

CD MECHANISM EXPLODED VIEW 1/1

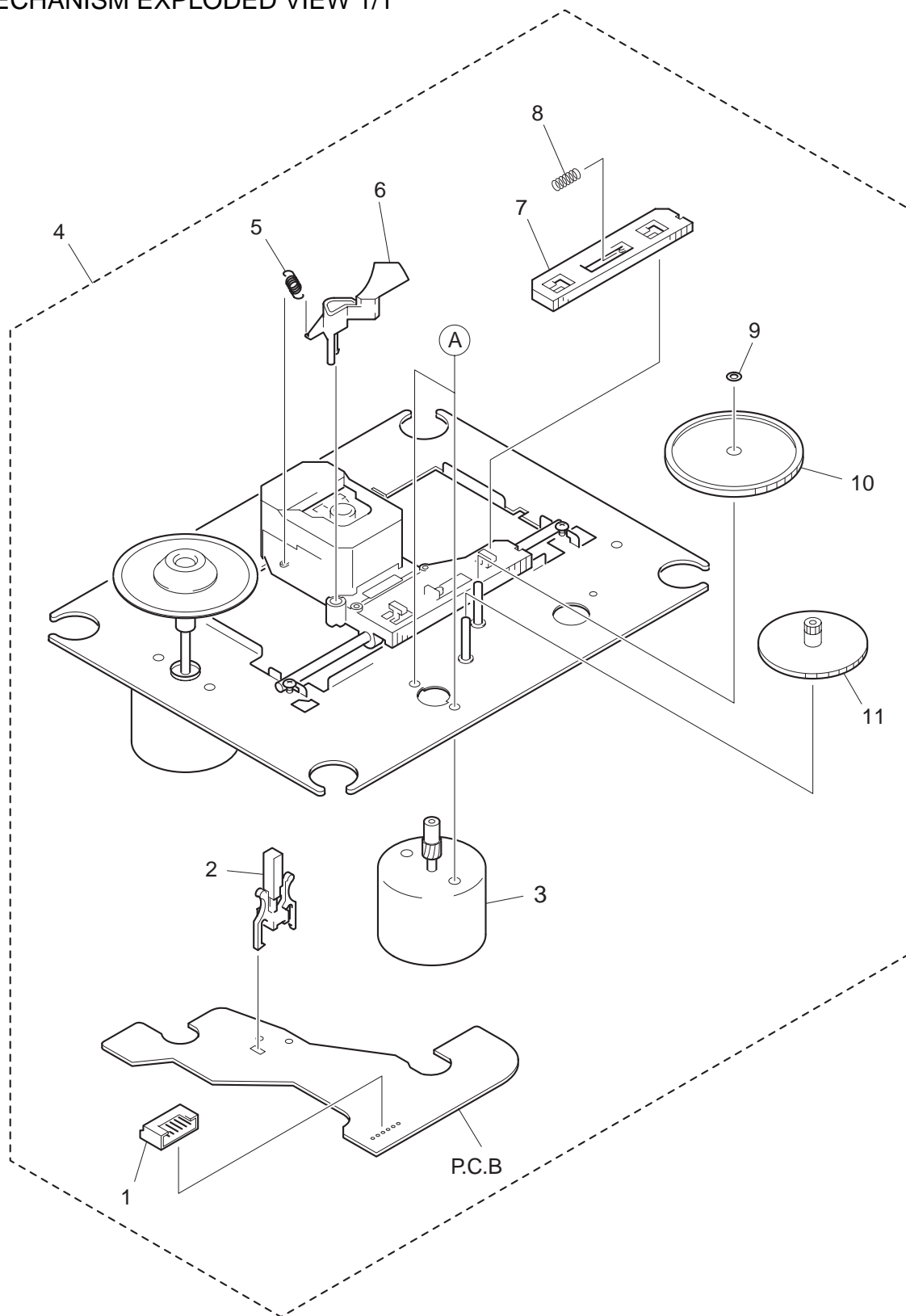

CD MECHANISM PARTS LIST 1/1

DESCRIPTIONで判断できない物は "REFERENCE NAME LIST" を参照してください。
 If can't understand for Description please kindly refer to "REFERENCE NAME LIST".

REF. NO	PART NO.	KANRI NO.	DESCRIPTION	REF. NO	PART NO.	KANRI NO.	DESCRIPTION
1	91-564-722-110		CONN, PIN 6P	8	92-647-742-010		SPRING COMPRESSION
2	91-572-085-110		LEAF SWITCH	9	93-321-813-110		POLI WASHER
3	9X-264-655-010		SL MOTORR ASSY	10	92-647-407-010		GEAR A
4	M8-ZZK-C90-070		KSM-880CAB	11	92-647-408-020		GEAR B
5	92-647-416-020		SPRING EXTENSION	A	93-713-786-510		SCREW, +P2-3
6	92-647-595-020		SHUTTER B				
7	92-647-732-010		NS SLIDE RACK				

REFERENCE NAME LIST

ELECTRICAL SECTION

DESCRIPTION	REFERENCE NAME
ANT	ANTENNAS
C-	CHIP
C-CAP	CAP, CHIP
C-CAP TN	CAP, CHIP TANTALUM
C-COIL	COIL, CHIP
C-DI	DIODE, CHIP
C-DIODE	DIODE, CHIP
C-FET	FET, CHIP
C-FOTR	FILTER, CHIP
C-JACK	JACK, CHIP
C-LED	LED, CHIP
C-RES	RES, CHIP
C-SFR	SFR, CHIP
C-SLIDE SW	SLIDE SWITCH, CHIP
C-SW	SWITCH, CHIP
C-TR	TRANSISTOR, CHIP
C-VR	VOLUME, CHIP
C-ZENER	ZENER, CHIP
CAP, CER	CAP, CERA-SOL
CAP, E	CAP, ELECT
CAP, M/F	CAP, FILM
CAP, TC	CAP, CERA-SOL
CAP, TC-U	CAP, CERA-SOL SS
CAP, TN	CAP, TANTALUM
CERA FIL	FILTER, CERAMIC
CF	FILTER, CERAMIC
DL	DELAY LINE
E/CAP	CAP, ELECT
FILT	FILTER
FLTR	FILTER
FUSE RES	RES, FUSE
MOT	MOTOR
P-DIODE	PHOTO DIODE
P-SNSR	PHOTO SENSER
P-TR	PHOTO TRANSISTOR
POLY VARI	VARIABLE CAPACITOR
PPCAP	CAP, PP
PT	POWER TRANSFORMER
PTR, RES	PTR, MELF
RC	REMOTE CONTROLLER
RES NF	RES, NON-FLAMMABLE
RESO	RESONATOR
SHLD	SHIELD
SOL	SOLENOID
SPKR	SPEAKER
SW, LVR	SWITCH, LEVER
SW, RTRY	SWITCH, ROTARY
SW, SL	SWITCH, SLIDE
TC CAP	CAP, CERA-SOL
THMS	THERMISTOR
TR	TRANSISTOR
TRIMMER	CAP, TRIMMER
TUN-CAP	VARIABLE CAPACITOR
VIB, CER	RESONATOR, CERAMIC
VIB, XTAL	RESONATOR, CRYSTAL
VR	VOLUME
ZENER	DIODE, ZENER

MECHANICAL SECTION

DESCRIPTION	REFERENCE NAME
ADHESHIVE	SHEET ADHESHIVE
AZ	AZIMUTH
BAR-ANT	BAR-ANTENNA
BAT	BATTERY
BATT	BATTERY
BRG	BEARING
BTN	BUTTON
CAB	CABINET
CASS	CASSETTE
CHAS	CHASSIS
CLR	COLLAR
CONT	CONTROL
CRSR	CURSOR
CU	CUSHION
CUSH	CUSHION
DIR	DIRECTION
DUBB	DUBBING
FL	FRONT LOADING
FLY-WHL	FLYWHEEL
FR	FRONT
FUN	FUNCTION
G-CU	G-CUSHION
HDL	HANDOL
HIMERON	CLOTH
HINGE, BAT	HINGE, BATTERY
HLDR	HOLDER
HT-SINK	HEAT SINK
IB	INSTRUCTION BOOKLET
IDLE	IDLER
IND, L-R	INDICATOR, L-R
KEY, CONT	KEY, CONTROL
KEY, PRGM	KEY, PROGRAM
KNOB, SL	KNOB, SLIDE
LBL	LABEL
LID, BATT	LID, BATTERY
LID, CASS	LID, CASSETTE
LVR	LEVER
P-SP	P-SPRING
PANEL, CONT	PANEL, CONTROL
PANEL, FR	PANEL, FRONT
PRGM	PROGRAM
PULLY, LOAD MO	PULLY, LOAD MOTOR
RBN	RIBBON
S-	SPECIAL
SEG	SEGMENT
SH	SHEET
SHLD-SH	SHIELD-SHEET
SL	SLIDE
SP	SPRING
SP-SCREW	SPECIAL-SCREW
SPACER, BAT	SPACER, BATTERY
SPR	SPRING
SPR-P	P-SPRING
SPR-PC-PUSH	P-SPRING, C-PUSH
T-SP	T-SPRING
TERM	TERMINAL
TRIG	TRIGGER
TUN	TUNING
VOL	VOLUME
W	WASHER
WHL	WHEEL
WORM-WHL	WORM-WHEEL

アイワ株式会社 〒110-8710 東京都台東区池之端1-2-11 ☎03(3827)3111 (代表)
AIWA CO.,LTD. 2-11, IKENOHATA 1-CHOME, TAITO-KU, TOKYO 110-8710, JAPAN TEL:03 (3827) 3111