

aiwa

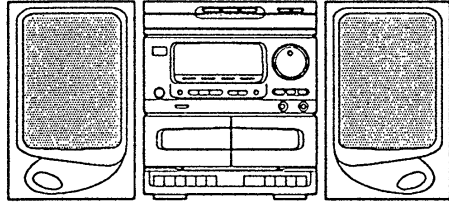

NSX-V20



COMPACT DISC /
STEREO CASSETTE RECEIVER

- BASIC TAPE MECHANISM: TN-21ZSW-1370(U)
TN-591SW-103(EXCEPT U) • TYPE: U, LH, HE, HR, EE, K, EZ
- BASIC CD MECHANISM: 4ZG1-FR

REVISION PUBLISHING

- This Service Manual is the "Revision Publishing" and replaces "Simple Manual":
(S/M Code No. 09-94B-086-00T).
- If requiring information about the mechanism, see Service Manual of 4ZG1,
S/M Code No. 09-946-056-10T.

SYSTEM	CD- CASSEIVER	REMOTE CONTROLLER	SPEAKERS
NSX-V20	CX-NV20	RC-TN340	SX-NV20

SPECIFICATIONS (U)

<FM section>

Frequency range	87.5 MHz to 108 MHz
Usable sensitivity (IHF)	1.3 μ V (75 ohms) 13.2 dBf
Alternate channel selectivity	50 dB (\pm 400 kHz)
Signal-to-noise ratio	STEREO: 70 dB MONO: 76 dB
Harmonic distortion	0.3 % (MONO), 1 kHz 0.5 % (STEREO, L-R), 1 kHz
Frequency response	30 Hz to 15 kHz (+0.5 dB, -3 dB)
Stereo separation	33 dB at 1 kHz
Antenna	75 ohms (unbalanced)

<AM section>

Frequency range	530 (531) kHz to 1710 (1602) kHz
Usable sensitivity	350 μ V/m
Selectivity	22 dB (10 kHz)
Signal-to-noise ratio	53 dB (100 dB input)
Antenna	Loop antenna

<Timer section>

Program timer	On-timer, capable of free setting
Sleep timer	Capable of setting in 10-minute increments, 240 minutes maximum

<Amplifier section>

Power output	FTC RULE 16 watts per channel, Min. RMS at 6 ohms, from 65 Hz to 15 kHz, with no more than 1 % Total Harmonic Distortion
Harmonic distortion	0.05 % (10 W, 1 kHz, 6 ohms)
Input sensitivity	VIDEO/AUX: 400 mV

<Cassette deck section>

Track format	4 tracks, 2 channels
Frequency response	Normal tape: 50 - 15000 Hz
Tape speed	4.8 cm/sec. (1 $\frac{7}{8}$ ips)
Recording system	AC bias
Erasure system	AC erase
Motor	DC servomotor \times 1
Heads	Playback head \times 1 (deck 2) Recording/playback \times 1 (deck 1) Erasure head \times 1 (deck 1)

<CD player section>

Disc	Compact disc
Scanning method	Non-contact optical scanner (semiconductor laser application)
Laser	Semiconductor laser ($\lambda = 780$ nm)
Rotation speed	Approx. 500 rpm - 200 rpm (CLV)
Error correction	Cross Interleave, Reed Solomon code
No. of channels	2 channels
D-A converter	1 bit dual
Wow/flutter	Unmeasurable
Signal-to-noise ratio	90 dB (1 kHz, 0 dB)
Harmonic distortion	0.05 % (1 kHz, 0 dB)

SPEAKER SYSTEM SX-NV20

(These values are for one speaker.)

Cabinet type	3 way, bass reflex (magnetism sealed type)
Speaker	130 mm (5 $\frac{1}{8}$ in.) cone type woofer 50 mm (2 in.) cone type tweeter 20 mm (1 $\frac{3}{16}$ in.) ceramic type super tweeter
Impedance	6 ohms
Music power	40 W
Output sound pressure level	87 dB/W/m
Dimensions (W \times H \times D)	220 \times 302 \times 220 mm (8 $\frac{3}{4}$ \times 12 \times 8 $\frac{3}{4}$ in.)
Weight	2.8 kg (6.2 lb.)

COMMON SECTION

Power requirements	AC 120 V, 60 Hz
Power consumption	55 W
Dimensions (W \times H \times D)	Main unit: 700 \times 305 \times 340 mm (27 $\frac{5}{8}$ \times 12 $\frac{1}{8}$ \times 13 $\frac{1}{2}$ in.) System: 620 \times 305 \times 340 mm (24 $\frac{1}{2}$ \times 12 $\frac{1}{8}$ \times 13 $\frac{1}{2}$ in.) Main unit: 6 kg (13.2 lb.) System: 11.2 kg (24.64 lb.)

• Design and specifications are subject to change without notice.

SPECIFICATIONS (LH)

<FM section>		<CD player section>	
Frequency range	87.5 MHz to 108 MHz	Disc	Compact disc
Usable sensitivity (IHF)	1.3 μ V (75 ohms) 13.2 dBf	Scanning method	Non-contact optical scanner (semiconductor laser application)
Alternate channel selectivity	50 dB (\pm 400 kHz)	Laser	Semiconductor laser ($\lambda = 780$ nm)
Signal-to-noise ratio	STEREO: 70 dB MONO: 76 dB	Rotation speed	Approx. 500 rpm – 200 rpm (CLV)
Harmonic distortion	0.3 % (MONO), 1 kHz 0.5 % (STEREO, L-R), 1 kHz	Error correction	Cross Interleave, Reed Solomon code
Frequency response	30 Hz to 15 kHz (+0.5 dB, – 3 dB)	No. of channels	2 channels
Stereo separation	33 dB at 1 kHz	D-A converter	1 bit dual
Antenna	75 ohms (unbalanced)	Wow/flutter	Unmeasurable
<AM section>		Signal-to-noise ratio	90 dB (1 kHz, 0 dB)
Frequency range	530 (531) kHz to 1710 (1602) kHz	Harmonic distortion	0.05% (1 kHz, 0 dB)
Usable sensitivity	350 μ V/m	SPEAKER SYSTEM SX-NV20	
Selectivity	22 dB (10 kHz)	(These values are for one speaker.)	
Signal-to-noise ratio	53 dB (100 dB input)	Cabinet type	3 way, bass reflex (magnetism sealed type)
Antenna	Loop antenna	Speaker	130 mm (5 ¹ / ₈ in.) cone type woofer 50 mm (2 in.) cone type tweeter 20 mm (1 ³ / ₁₆ in.) ceramic type super tweeter
<Timer section>		Impedance	6 ohms
Program timer	On-timer, capable of free setting	Music power	40 W
Sleep timer	Capable of setting in 10-minute increments, 240 minutes maximum	Output sound pressure level	87 dB/W/m
<Amplifier section>		Dimensions (W \times H \times D)	220 \times 302 \times 220 mm (8 ³ / ₄ \times 12 \times 8 ³ / ₄ in.)
Power output	20 W + 20 W (6 ohms, T.H.D. 10% 1 kHz)	Weight	2.8 kg (6.2 lb.)
Harmonic distortion	0.05% (10 W, 1 kHz, 6 ohms)	COMMON SECTION	
Input sensitivity	VIDEO/AUX: 400 mV	Power requirements	AC 120 V/220 – 240 V, switchable 50/60 Hz
<Cassette deck section>		Power consumption	50 W
Track format	4 tracks, 2 channels	Dimensions (W \times H \times D)	Main unit: 260 \times 305 \times 340 mm (10 ¹ / ₄ \times 12 ¹ / ₈ \times 13 ¹ / ₂ in.)
Frequency response	Normal tape: 50 – 15000 Hz	System:	700 \times 305 \times 340 mm (27 ⁵ / ₈ \times 12 ¹ / ₈ \times 13 ¹ / ₂ in.)
Tape speed	4.8 cm/sec. (1 ⁷ / ₈ ips)	Weight	Main unit: 6 kg (13.2 lb.) System: 11.2 kg (24.64 lb.)
Recording system	AC bias		
Erase system	AC erase		
Motor	DC servomotor \times 1		
Heads	Playback head \times 1 (deck 2) Recording/playback \times 1 (deck 1) Erase head \times 1 (deck 1)		

● Design and specifications are subject to change without notice.

SPECIFICATIONS (HE, HR)

<FM section>

Frequency range	87.5 MHz to 108 MHz
Usable sensitivity(IHF)	1.3 μ V (75 ohms) 13.2 dBf
Alternate channel selectivity	50 dB (\pm 400 kHz)
Signal-to-noise ratio	STEREO: 70 dB MONO: 76 dB
Harmonic distortion	0.3% (MONO), 1 kHz 0.5% (STEREO, L-R), 1 kHz
Frequency response	30 Hz to 15 kHz (+ 0.5 dB, -3 dB)
Stereo separation	33 dB at 1 kHz
Antenna	75 ohms (unbalanced)

<AM section>

Frequency range	531 (530) kHz to 1602 (1710) kHz
Usable sensitivity	350 μ V/m
Selectivity	22 dB (9 kHz)
Signal-to-noise-ratio	53 dB (100 dB input)
Antenna	Loop antenna

<Timer section>

Program timer	On-timer, capable of free setting
Sleep timer	Capable of setting in 10-minute Increments, 240 minutes maximum

<Amplifier section>

Power output	20 W + 20 W (6 ohms, T.H.D. 10% 1 kHz)
Harmonic distortion	0.05% (10 W, 1 kHz, 6 ohms)
Input sensitivity	VIDEO/AUX: 400 mV

<Cassette deck section>

Track format	4 tracks, 2 channels
Frequency response	Normal tape: 50-15000 Hz
Tape speed	4.8 cm/sec.(1 7/8 ips)
Recording system	AC bias
Erase system	AC erase
Motor	DC servomotor \times 1
Heads	Playback head \times 1 (deck 2) Recording/playback \times 1 (deck 1) Erase head \times 1 (deck 1)

<CD player section>

Disc	Compact disc
Scanning method	Non-contact optical scanner (semiconductor laser application)
Laser	Semiconductor laser ($\lambda = 780$ nm)
Rotation speed	Approx. 500 rpm-200 rpm (CLV)
Error correction	Cross Interleave, Reed Solomon code
No. of channels	2 channels
D-A converter	1 bit dual
Wow/flutter	Unmeasurable
Signal-to-noise ratio	90 dB (1 kHz, 0 dB)
Harmonic distortion	0.05% (1 kHz, 0 dB)

SPEAKER SYSTEM SX-NV20

(These values are for one speaker.)

Cabinet type	3 way, bass reflex (magnetism sealed type)
Speaker	130 mm (5 1/8 in.) cone type woofer 50 mm (2 in.) cone type tweeter 20 mm (13/16 in.) ceramic type super tweeter
Impedance	6 ohms
Music power	40 W
Output sound pressure level	87 dB/W/m
Dimensions(W \times H \times D)	220 \times 302 \times 220 mm (8 3/4 \times 12 \times 8 3/4 in.)
Weight	2.8 kg (6.2 lb.)

COMMON SECTION

Power requirements	CX-NV20 HE: AC 120 V/220-240 V, switchable 50/60 Hz CX-NV20 HR: AC 120V/230-240V, switchable 50/60 Hz
Power consumption	CX-NV20 HE: 50 W CX-NV20 HR: 65 W
Dimensions(W \times H \times D)	Main unit: 260 \times 305 \times 340 mm (10 1/4 \times 12 1/8 \times 13 1/2 in.) System: 700 \times 305 \times 340 mm (27 5/8 \times 12 1/8 \times 13 1/2 in.)
Weight	Main unit: 6 kg (13.2 lb.) System: 11.2 kg (24.64 lb.)

• Design and specifications are subject to change without notice.

SPECIFICATIONS (EE, K, EZ)

<FM section>

Frequency range	87.5 MHz to 108 MHz
Usable sensitivity (IHF)	1.3 μ V (75 ohms) 13.2 dB
Alternate channel selectivity	50 dB (\pm 400 kHz)
Signal-to-noise ratio	STEREO: 70 dB MONO: 76 dB
Harmonic distortion	0.3 % (MONO), 1 kHz 0.5 % (STEREO, L-R), 1 kHz
Frequency response	30 Hz to 15 kHz (+0.5 dB, -3 dB)
Stereo separation	33 dB at 1 kHz
Antenna	75 ohms (unbalanced)

<MW section>

Frequency range	531 (530) kHz to 1602 (1710) kHz
Usable sensitivity	350 μ V/m
Selectivity	22 dB (9 kHz)
Signal-to-noise ratio	53 dB (100 dB input)
Antenna	Loop antenna

<LW section >

Frequency range	144 kHz to 290 kHz
Sensitivity	1400 μ V/m
Antenna	Loop antenna

<Timer section>

Program timer	On-timer, capable of free setting
Sleep timer	Capable of setting in 10-minute increments, 240 minutes maximum

<Amplifier section>

Power output	CX-NV20 EE, EZ, K: 20 W + 20 W (6 ohms, T.H.D. 10 %, 1 kHz) 16 W + 16 W (6 ohms, T.H.D. 1 %, 1 kHz)
Harmonic distortion	0.05 % (10 W, 1 kHz, 6 ohms)
Input sensitivity	VIDEO/AUX: 400 mV

<Cassette deck section>

Track format	4 tracks, 2 channels
Frequency response	Normal tape: 50 - 15000 Hz
Tape speed	4.8 cm/sec. (1 $\frac{7}{8}$ ips)
Recording system	AC bias
Erasure system	AC erase
Motor	DC servomotor \times 1
Heads	Playback head \times 1 (deck 2) Recording/playback \times 1 (deck 1) Erasure head \times 1 (deck 1)

<CD player section>

Disc	Compact disc
Scanning method	Non-contact optical scanner (semi-conductor laser application)
Laser	Semiconductor laser ($\lambda = 780$ nm)
Rotation speed	Approx. 500 rpm - 200 rpm (CLV)
Error correction	Cross Interleave, Reed Solomon code
No. of channels	2 channels
D-A converter	1 bit dual
Wow/flutter	Unmeasurable
Signal-to-noise ratio	90 dB (1 kHz, 0 dB)
Harmonic distortion	0.05% (1 kHz, 0 dB)

SPEAKER SYSTEM SX-NV20

(These values are for one speaker.)

Cabinet type	3 way, bass reflex (magnetism sealed type)
Speaker	130 mm (5 $\frac{1}{8}$ in.) cone type woofer 50 mm (2 in.) cone type tweeter 20 mm (1 $\frac{3}{16}$ in.) ceramic type super tweeter
Impedance	6 ohms
Music power	40 W
Output sound pressure level	87 dB/W/m
Dimensions (W \times H \times D)	SX-NV20: 220 \times 302 \times 220 mm (8 $\frac{3}{4}$ \times 12 \times 8 $\frac{3}{4}$ in.)
Weight	SX-NV20: 2.8 kg (6.2 lbs.)

COMMON SECTION

Power requirements	CX-NV20 EE, EZ: AC 230 V, 50 Hz CX-NV20 K: AC 230 V - 240 V, 50 Hz CX-NV20 EE, EZ, K: 110 W
Power consumption	Main unit: 260 \times 305 \times 340 mm (10 $\frac{1}{4}$ \times 12 $\frac{1}{8}$ \times 13 $\frac{1}{2}$ in.) System: NSX-V20: 700 \times 305 \times 340 mm (27 $\frac{5}{8}$ \times 12 $\frac{1}{8}$ \times 13 $\frac{1}{2}$ in.)
Dimensions (W \times H \times D)	Main unit: 6 kg (13.2 lb.) System: NSX-V20: 11.6 kg (25.52 lb.)
Weight	

● Design and specifications are subject to change without notice.

PROTECTION OF EYES FROM LASER BEAM DURING SERVICING

This set employs laser. Therefore, be sure to follow carefully the instructions below when servicing.

WARNING!

WHEN SERVICING, DO NOT APPROACH THE LASER EXIT WITH THE EYE TOO CLOSELY. IN CASE IT IS NECESSARY TO CONFIRM LASER BEAM EMISSION. BE SURE TO OBSERVE FROM A DISTANCE OF MORE THAN 30cm FROM THE SURFACE OF THE OBJECTIVE LENS ON THE OPTICAL PICK-UP BLOCK.

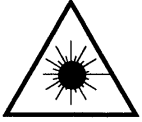

- Caution: Invisible laser radiation when open and interlocks defeated avoid exposure to beam.
- Advarsel: Usynlig laserstråling ved åbning, når sikkerhedsafbrydere er ude af funktion. Undgå udsættelse for stråling.

VAROITUS!

Laiteen Käyttäminen muulla kuin tässä käyttöohjeessa mainitulla tavalla saattaa altistaa käyttäjän turvallisuusluokan 1 ylitävälle näkymättömälle lasersäteilylle.

WARNING!

Om apparaten används på annat sätt än vad som specificeras i denna bruksanvisning, kan användaren utsättas för osynlig laserstrålning, som överskrider gränsen för laserklass 1.

CAUTION

Use of controls or adjustments or performance of procedures other than those specified herein may result in hazardous radiation exposure.

ATTENTION

L'utilisation de commandes, réglages ou procédures autres que ceux spécifiés peut entraîner une dangereuse exposition aux radiations.

ADVARSEL!

Usynlig laserstråling ved åbning, når sikkerhedsafbrydere er ude af funktion. Undgå udsættelse for stråling.

This Compact Disc player is classified as a CLASS 1 LASER product.

The CLASS 1 LASER PRODUCT label is located on the rear exterior.

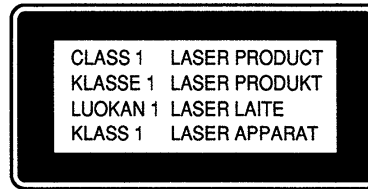

Precaution to replace Optical block (KSS – 210A)

Body or clothes electrostatic potential could ruin laser diode in the optical block. Be sure to ground body and workbench, and use care the clothes do not touch the diode.

- 1) After the connection, remove the solder shown in the right figure.

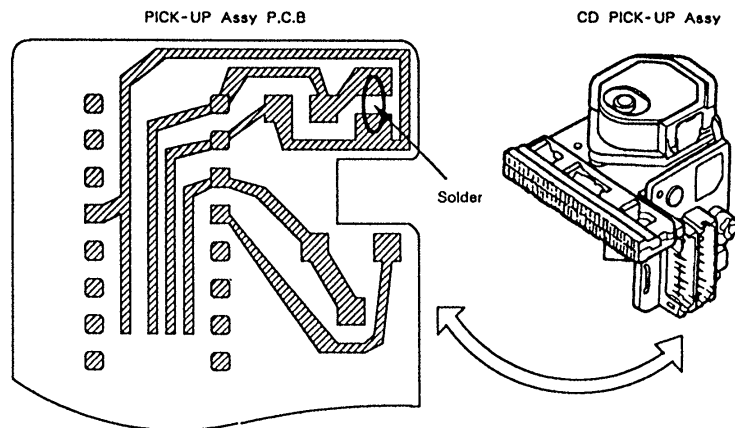

ELECTRICAL MAIN PARTS LIST

DESCRIPTION で判断できない物は“REFERENCE NAME LIST”を参照してください。
If can't understand for Description please kindly refer to “REFERENCE NAME LIST”.

REF. NO	PART NO.	カフリ NO.	DESCRIPTION	REF. NO	PART NO.	カフリ NO.	DESCRIPTION
IC				C113	87-010-403-089		CAP, E 3.3-50 SME
	82-NF7-641-010	IC,	UPD78044GF-103	C115	87-018-209-089		CAP, TC-U 0.1-50 F
	87-017-373-019	IC,	NJH32H380A	C116	87-018-127-089		CAP, TC-U 470P-50 B
	87-020-899-019	IC,	STK4122-MK2	C118	87-018-209-089		CAP, TC-U 0.1-50 F
	87-020-758-019	IC,	NJM 2068 SD	C213	87-010-401-089		CAP, E 1-50 SME(U)
	87-002-727-019	IC,	NJM4558L	C213	87-010-404-089		CAP, E 4.7-50 SME(EXCEPT U)
	87-017-804-019	IC,	BU4052BCP	C214	87-010-401-089		CAP, E 1-50 SME(U)
	87-017-374-019	IC,	TC4094BP	C214	87-010-404-089		CAP, E 4.7-50 SME(EXCEPT U)
	87-017-698-080	IC,	M65843FP(HE, HR)	C215	87-018-128-089		CAP, TC-U 560P-50 B
	87-002-607-019	IC,	LM7001	C216	87-018-128-089		CAP, TC-U 560P-50 B
	87-017-434-019	IC,	K1A6043S	C217	87-010-546-089		CAP, E 0.33-50 SME
	87-001-942-019	IC,	LA1265S(G)	C218	87-010-546-089		CAP, E 0.33-50 SME
				C219	87-010-263-089		CAP, E 100-10(EXCEPT U)
				C220	87-010-263-089		CAP, E 100-10(EXCEPT U)
				C221	87-010-401-089		CAP, E 1-50 SME(U)
TRANSISTOR				C221	87-010-402-089		CAP, E 2.2-50 SME(EXCEPT U)
	89-213-702-019	TR,	2SB1370E	C222	87-010-401-089		CAP, E 1-50 SME(U)
	89-113-187-089	TR,	2SA1318TU	C222	87-010-402-089		CAP, E 2.2-50 SME(EXCEPT U)
	89-332-665-089	TR,	2SC3266GR(EXCEPT U)	C223	87-010-263-089		CAP, E 100-10 SME 5X11(U)
	89-318-155-089	TR,	2SC1815GR	C223	87-010-374-089		CAP, E 47-10(EXCEPT U)
	87-026-462-089	TR,	2SC1740S(RS)	C224	87-010-263-089		CAP, E 100-10 SME 5X11(U)
	89-420-053-089	TR,	2SD2005R(U)	C224	87-010-374-089		CAP, E 47-10(EXCEPT U)
	89-406-555-089	TR,	2SD655E	C225	87-010-260-089		CAP, E 47-25 SME
	87-026-286-089	TR,	DTA143ES	C226	87-010-260-089		CAP, E 47-25 SME
	87-026-218-089	TR,	DTC144ES	C236	87-010-408-089		CAP, E 47-50 SME
	87-026-292-089	TR,	DTA144WS	C237	87-018-134-089		CAP, TC-U 0.01-16 Y(K, EE, EZ)
	89-502-466-089	TR,	FET 2SK246-BL(TPE2)	C238	87-018-134-089		CAP, TC-U 0.01-16 Y(K, EE, EZ)
	87-026-463-089	TR,	2SA933S(RS)	C243	87-018-104-089		CAP, TC-U 10P-50 SL
	87-026-572-089	TR,	DTA114TS	C244	87-018-104-089		CAP, TC-U 10P-50 SL
	89-110-155-089	TR,	2SA1015GR	C250	87-010-404-089		CAP, E 4.7-50 SME
	89-333-317-089	TR,	2SC3331T	C251	87-018-134-089		CAP, TC-U 0.01-16 Y(K, EE, EZ)
	89-109-705-089	TR,	2SA970GR(K, EE, EZ)	C303	87-018-131-089		CAP, TC-U 1000P-50 B(U)
	87-026-289-089	TR,	DTC143XS(TP)	C303	87-018-127-089		CAP, TC-U 470P-50 B(EXCEPT U)
	89-502-464-089	FET,	2SK246Y	C304	87-018-131-089		CAP, TC-U 1000P-50 B(U)
	89-318-154-089	TR,	2SC1815Y	C304	87-018-127-089		CAP, TC-U 470P-50 B(EXCEPT U)
	87-026-214-089	TR,	DTA114YS	C310	87-018-134-089		CAP, TC-U 0.01-16 Y
	89-319-233-089	TR,	2SC1923(O)	C313	87-018-205-089		CAP, TC-U 0.022-25 F
	89-502-415-089	FET,	2SK241GR	C351	87-018-121-089		CAP, TC-U 150P-50 B
	89-501-615-089	FET,	2SK161GR	C352	87-018-121-089		CAP, TC-U 150P-50 B
	89-320-011-089	TR,	2SC2001K(K, EE, EZ)	C353	87-018-125-089		CAP, TC-U 330P-50 B
DIODE				C354	87-018-125-089		CAP, TC-U 330P-50 B
	87-002-225-019	DIODE,	DBF 40C-K10	C355	87-010-260-089		CAP, E 47-25 SME
	87-017-978-089	DIODE,	1N4003(HE, LH)	C361	87-018-134-089		CAP, TC-U 0.01-16 Y
	87-017-430-090	DIODE,	RK14(HR, K, EE, EZ)	C362	87-018-134-089		CAP, TC-U 0.01-16 Y
	87-017-430-010	DIODE,	RK14(K, EE, EZ)	C365	87-018-205-089		CAP, TC-U 0.022-25 F
	87-001-574-089	DIODE,	1SR139-200 T31	C366	87-018-134-089		CAP, TC-U 0.01-16 Y
	87-020-691-089	DIODE,	1SS132 T-72	C401	87-010-402-089		CAP, E 2.2-50 SME
	87-020-465-089	DIODE,	1SS133	C402	87-010-402-089		CAP, E 2.2-50 SME
	87-017-173-089	ZENER,	HZS11A2L	C403	87-018-132-089		CAP, TC-U 2200P-16 X
	87-017-144-089	ZENER,	HZS242	C404	87-018-132-089		CAP, TC-U 2200P-16 X
	87-001-731-089	ZENER,	HZS6C2L	C407	87-010-401-089		CAP, E 1-50 SME
	87-017-091-089	ZENER,	HZS5C1	C408	87-010-401-089		CAP, E 1-50 SME
	87-001-290-089	ZENER,	HZS6B1L	C421	87-018-130-089		CAP, TC-U 820P-50 B
	87-001-913-089	ZENER,	UTZJ5.6B	C422	87-018-130-089		CAP, TC-U 820P-50 B
				C451	87-018-126-089		CAP, TC-U 390P-50 B
MAIN C. B				C452	87-018-126-089		CAP, TC-U 390P-50 B
BPF731	82-794-697-019	FILTER,	ANT BIRDIE(K, EE, EZ)	C453	87-018-131-089		CAP, TC-U 1000P-50 B
C101	87-010-398-099	CAP,	E 2200-35V	C455	87-018-131-089		CAP, TC-U 1000P-50 B(K, EE, EZ)
C102	87-010-399-099	CAP,	E 3300-35 SME	C456	87-010-385-089		CAP, E 220-25 SME
C104	87-010-980-089	CAP,	E 330-16 FS	C501	87-010-401-089		CAP, E 1-50 SME
C105	87-010-101-089	CAP,	E 220-16 SME	C502	87-010-401-089		CAP, E 1-50 SME
C106	87-010-247-089	CAP,	E 100-50 SME	C503	87-018-195-089		CAP, TC-U 1200P-16 X
C107	87-010-384-089	CAP,	E 100-25 SME	C504	87-018-195-089		CAP, TC-U 1200P-16 X
C108	87-010-384-089	CAP,	E 100-25 SME	C505	87-010-546-089		CAP, E 0.33-50 SME
C109	87-010-263-089	CAP,	E 100-10 SME 5X11	C506	87-010-546-089		CAP, E 0.33-50 SME
C110	87-010-263-089	CAP,	E 100-10 SME 5X11	C507	87-018-196-089		CAP, TC-U 1500P-16 X(EXCEPT U)
C112	87-010-260-089	CAP,	E 47-25 SME	C507	87-018-130-089		CAP, TC-U 820P-50 B(U)
				C508	87-018-196-089		CAP, TC-U 1500P-16 X(EXCEPT U)
				C508	87-018-130-089		CAP, TC-U 820P-50 B(U)
				C509	87-010-371-089		CAP, E 470-6.3

REF. NO	PART NO.	カブリ NO.	DESCRIPTION	REF. NO	PART NO.	カブリ NO.	DESCRIPTION
C517	87-018-104-089		CAP, TC-U 10P-50 SL	C820	87-018-209-089		CAP, TC-U 0.1-50 F(U, HE, HR, LH)
C518	87-018-104-089		CAP, TC-U 10P-50 SL	C821	87-018-134-089		CAP, TC-U 0.01-16 Y
C590	87-018-209-089		CAP, TC-U 0.1-50 F	C822	87-018-103-089		CAP, TC-U 8.2P-50 SL
C592	87-010-404-089		CAP, E 4.7-50 SME	C823	87-018-107-089		CAP, TC-U 18P-50 SL
C593	87-010-404-089		CAP, E 4.7-50 SME	C826	87-018-134-089		CAP, TC-U 0.01-16 Y(K, EE, EZ)
C594	87-010-404-089		CAP, E 4.7-50 SME	C830	87-018-134-089		CAP, TC-U 0.01-16 Y(K, EE, EZ)
C595	87-010-112-089		CAP, E 100-16	C831	87-018-105-089		CAP, TC-U 12P-50 SL(K, EE, EZ)
C628	87-010-260-089		CAP, E 47-25 SME	C831	87-018-102-089		CAP, TC-U 6.8P-50 SL(U, HE, HR, LH)
C636	87-010-404-089		CAP, E 4.7-50 SME	C832	87-018-108-089		CAP, TC-U 20P-50 SL(K, EE, EZ)
C700	87-010-221-089		CAP, E 470-10	C833	87-018-209-089		CAP, TC-U 0.1-50 F(U, HE, HR, LH)
C701	87-010-384-089		CAP, E 100-25 SME	C834	87-018-103-089		CAP, TC-U 8.2P-50 SL(K, EE, EZ)
C702	87-010-404-089		CAP, E 4.7-50 SME	C839	87-018-134-089		CAP, TC-U 0.01-16 Y
C703	87-018-134-089		CAP, TC-U 0.01-16 Y	C847	87-018-134-089		CAP, TC-U 0.01-16 Y
C705	87-010-248-089		CAP, E 220-10 SME	C848	87-018-113-089		CAP, TC-U 33P-50 SL(K, EE, EZ)
C706	87-018-134-089		CAP, TC-U 0.01-16 Y	C849	87-018-134-089		CAP, TC-U 0.01-16 Y(K, EE, EZ)
C707	87-018-134-089		CAP, TC-U 0.01-16 Y	C852	87-018-209-089		CAP, TC-U 0.1-50 F
C708	87-018-134-089		CAP, TC-U 0.01-16 Y	C941	87-018-134-089		CAP, TC-U 0.01-16 Y(K, EE, EZ)
C710	87-018-149-089		CAP, TC-U 15P-50 CH	C942	87-018-105-089		CAP, TC-U 12P-50 SL(K, EE, EZ)
C715	87-018-195-089		CAP, TC-U 1200P-16 X	C944	87-018-104-089		CAP, TC-U 10P-50 SL(K, EE, EZ)
C716	87-018-195-089		CAP, TC-U 1200P-16 X	C944	87-018-105-089		CAP, TC-U 12P-50 SL(U, HE, HR, LH)
C720	87-018-121-089		CAP, TC-U 150P-50 B	C945	87-014-050-089		CAP, PP 510P-100 J(K, EE, EZ)
C721	87-010-401-089		CAP, E 1-50 SME	C946	87-010-401-089		CAP, E 1-50 SME
C722	87-010-401-089		CAP, E 1-50 SME	C949	87-018-209-089		CAP, TC-U 0.1-50 F(K, EE, EZ)
C723	87-010-405-089		CAP, E 10-50 SME	C983	87-010-544-089		CAP, E 0.1-50
C724	87-014-057-089		CAP, PP 1000P-100 J	C990	87-018-134-089		CAP, TC-U 0.01-16 Y
C725	87-010-401-089		CAP, E 1-50 SME	CF741	82-794-670-019		BFU, 450C4N
C726	87-010-403-089		CAP, E 3.3-50 SME	CF801	87-008-264-010		FLTR, SFE 10.7MS2-A(K, EE, EZ)
C727	87-010-248-089		CAP, E 220-10 SME	CF801	87-008-261-019		FLTR, SFE10.7MA5-A(U, HE, HR, LH)
C728	87-010-402-089		CAP, E 2.2-50 SME(K, EE, EZ)	CF802	87-008-261-019		FLTR, SFE10.7MA5-A
C729	87-010-402-089		CAP, E 2.2-50 SME(K, EE, EZ)	CF803	87-008-261-019		FLTR, SFE10.7MA5-A(K, EE, EZ)
C731	87-018-134-089		CAP, TC-U 0.01-16 Y	CF831	87-030-105-019		FLTR, BPM6A(K, EE, EZ)
C732	87-018-134-089		CAP, TC-U 0.01-16 Y	D801	87-027-900-019		VARI-CAP, 1SV147
C733	87-018-205-089		CAP, TC-U 0.022-25 F(K, EE, EZ)	D802	87-027-900-019		VARI-CAP, 1SV147
C741	87-010-402-089		CAP, E 2.2-50 SME	D803	87-027-900-019		VARI-CAP, 1SV147
C742	87-018-125-089		CAP, TC-U 330P-50 B(U, HE, HR, LH)	D804	87-027-900-019		VARI-CAP, 1SV147(K, EE)
C742	87-018-126-089		CAP, TC-U 390P-50 B(K, EE, EZ)	D804	87-027-900-019		VARI-CAP, 1SV147(K, EE, EZ)
C743	87-010-382-089		CAP, E 22-25 SME	ICP1	87-001-486-019		IC, ICP-N15(U)
C744	87-018-134-089		CAP, TC-U 0.01-16 Y	J250	87-049-855-019		JACK, 6.3 W/S
C745	87-018-134-089		CAP, TC-U 0.01-16 Y	J253	87-009-621-019		JACK, PIN 1P BLK
C746	87-010-401-089		CAP, E 1-50 SME	J254	87-033-226-019		TERMINAL, SP 4P (JT) (U, HE, HR, LH)
C748	87-010-404-089		CAP, E 4.7-50 SME	J254	87-033-227-019		TERMINAL, SP 4P R (Z) (K, EE, EZ)
C749	87-010-405-089		CAP, E 10-50 SME	J652	87-099-491-019		JACK, PIN 2P
C750	87-010-544-089		CAP, E 0.1-50	J801	81-631-646-019		ANT TERM 2P PAL(K, EE, EZ)
C751	87-010-403-089		CAP, E 3.3-50 SME	J801	82-NF5-621-019		ANT TERM JBT Q222(U, HE, HR, LH)
C752	87-018-134-089		CAP, TC-U 0.01-16 Y	L231	87-003-383-019		COIL, 1UH-S(K, EE, EZ)
C754	87-010-260-089		CAP, E 47-25 SME	L232	87-003-383-019		COIL, 1UH-S(K, EE, EZ)
C755	87-010-401-089		CAP, E 1-50 SME	L401	87-003-131-089		COIL, 10MH J
C756	87-018-134-089		CAP, TC-U 0.01-16 Y	L402	87-003-131-089		COIL, 10MH J
C760	87-018-134-089		CAP, TC-U 0.01-16 Y(U, HE, HR, LH)	L451	87-007-300-019		COIL, OSC BIAS 85K
C802	87-018-104-089		CAP, TC-U 10P-50 SL(U, HE, HR, LH)	L741	81-631-611-019		COIL, QUAD (SINGLE)
C802	87-018-105-089		CAP, TC-U 12P-50 SL(K, EE, EZ)	L742	87-008-491-019		FLTR, PACFAZ 450
C804	87-018-102-089		CAP, TC-U 6.8P-50 SL(U, HE, HR, LH)	L801	87-006-219-019		COIL, ANT FM 3/4T, S
C805	87-018-097-089		CAP, TC-U 2.2P-50 SL(K, EE, EZ)	L802	87-006-243-010		COIL, ANT FM2-3/4TS, L
C805	87-018-098-089		CAP, TC-U 3.3P-50 SL(U, HE, HR, LH)	L803	87-006-244-019		COIL, RF FM 3-1/2T, L4
C806	87-018-096-089		CAP, TC-U 1P-50 SL	L804	87-006-246-019		COIL, RF FM 3-1/2T, L4
C807	87-018-109-089		CAP, TC-U 22P-50 SL(K, EE, EZ)	L805	87-003-098-089		COIL, 2.2UH
C807	87-018-100-089		CAP, TC-U 4.7P-50 SL(U, HE, HR, LH)	L806	87-003-145-089		COIL, 8.2UH LAL02
C808	87-018-119-089		CAP, TC-U 100P-50 B	L807	87-007-259-010		COIL, FM OSC (7K)N
C809	87-018-134-089		CAP, TC-U 0.01-16 Y	L831	87-006-245-019		COIL, RF FM4TSR, L5(K, EE, EZ)
C810	87-018-134-089		CAP, TC-U 0.01-16 Y	L832	87-003-098-089		COIL, 2.2UH
C811	87-018-116-089		CAP, TC-U 56P-50 SL	L941	87-006-208-019		COIL, ANT LW(K, EE, EZ)
C812	87-018-107-089		CAP, TC-U 18P-50 SL	L942	87-007-305-019		COIL, OSC LW S(K, EE, EZ)
C813	87-018-134-089		CAP, TC-U 0.01-16 Y	L981	81-MX4-620-019		AM PACK 3, S(U, HE, HR, LH)
C814	87-018-134-089		CAP, TC-U 0.01-16 Y	L981	81-MX4-619-010		AM PACK 4(K, EE, EZ)
C815	87-018-134-089		CAP, TC-U 0.01-16 Y	R105	87-022-050-089		RESIS, METAL 1W-0.22J
C816	87-018-134-089		CAP, TC-U 0.01-16 Y	R106	87-022-050-089		RESIS, METAL 1W-0.22J
C817	87-018-134-089		CAP, TC-U 0.01-16 Y	R243	87-022-184-089		RES, METAL 0.33-1W(EXCEPT U)
C818	87-018-209-089		CAP, TC-U 0.1-50 F	R244	87-022-184-089		RES, METAL 0.33-1W(EXCEPT U)
C819	87-018-134-089		CAP, TC-U 0.01-16 Y	SFR451	87-024-173-089		SFR, 22K DIA6 V
C820	87-010-260-089		CAP, E 47-25 SME	SFR452	87-024-173-089		SFR, 22K DIA6 V

REF. NO	PART NO.	カンリ NO.	DESCRIPTION	REF. NO	PART NO.	カンリ NO.	DESCRIPTION
SFR721	87-024-171-089		SFR, 4.7K DIA6 V	C625	87-010-401-049		CAP, E 1-50 SME
SFR722	87-024-174-089		SFR, 33K DIA6 V	C626	87-010-401-049		CAP, E 1-50 SME
TC701	87-011-221-089		TRIMMER, 30P VCT51	C627	87-018-205-089		CAP, TC-U 0.022-25 F
TC801	87-011-219-089		CAP, TRIMMER 10P VCT	C628	87-018-209-089		CAP, TC-U 0.1-50 F
TC802	87-011-219-089		CAP, TRIMMER 10P VCT	C631	87-018-134-089		CAP, TC-U 0.01-16 Y
TC803	87-011-219-089		CAP, TRIMMER 10P VCT(K, EE, EZ)	C632	87-018-131-019		CAP, TC-U 1000P-50 B
TC942	87-011-221-089		TRIMMER, 30P VCT51(K, EE, EZ)	C710	87-018-209-089		CAP, TC-U 0.1-50 F(HE, HR)
W103	82-NF7-670-019		CABLE, FFC 6P-1.25	C711	87-018-134-089		CAP, TC-U 0.01-16 Y(HE, HR)
W101	83-NE2-618-019		F-CABEL, 5P-2.5	C712	87-018-132-019		CAP, TC-U 2200P-16 X(HE, HR)
X701	87-030-163-019		VIB, XTAL 7.2MHZ(NDK)	C713	87-018-209-089		CAP, TC-U 0.1-50 F(HE, HR)
FRONT C. B				C714	87-010-234-019		CAP, E 47-16 5L(HE, HR)
C100	87-018-209-089		CAP, TC-U 0.1-50 F	C718	87-018-134-089		CAP, TC-U 0.01-16 Y(HE, HR)
C201	87-018-131-089		CAP, TC-U 1000P-50 B	C719	87-018-199-089		CAP, TC-U 3300P-16 X(HE, HR)
C202	87-018-209-089		CAP, TC-U 0.1-50 F	C720	87-010-401-049		CAP, E 1-50 SME(HE, HR)
C203	87-010-404-049		CAP, E 4.7-50 SME	C721	87-018-133-019		CAP, TC-U 4700P-16 X(HE, HR)
C204	87-010-404-049		CAP, E 4.7-50 SME	C722	87-010-263-019		CAP, E 100-10(HE, HR)
C205	87-010-263-049		CAP, E 100-10	C723	87-018-209-089		CAP, TC-U 0.1-50 F(HE, HR)
C206	87-010-401-049		CAP, E 1-50 SME	C724	87-018-127-019		CAP, TC-U 470P-50 B(HE, HR)
C207	87-010-401-049		CAP, E 1-50 SME	C725	87-018-127-019		CAP, TC-U 470P-50 B(HE, HR)
C208	87-010-248-049		CAP, E 220-10 SME	C726	87-010-374-019		CAP, E 47-10 SME(HE, HR)
C209	87-018-209-089		CAP, TC-U 0.1-50 F	FL101	82-NF7-631-019		FL 7BT-185GK
C210	87-010-405-049		CAP, E 10-50 SME	J501	82-NF7-630-019		JACK, 3.5 MO
C211	87-010-408-049		CAP, E 47-50 SME	J502	82-NF7-630-019		JACK, 3.5 MO
C212	87-018-209-089		CAP, TC-U 0.1-50 F	L701	87-005-456-089		COIL, 1000UH FLR50, K(HE, HR)
C215	87-018-209-089		CAP, TC-U 0.1-50 F	S301	87-036-215-089		SW, TACT EVQ21404M
C216	87-018-209-019		CAP, TC-U 0.1-50 F	S302	87-036-215-089		SW, TACT EVQ21404M
C217	87-018-134-089		CAP, TC-U 0.01-16 Y	S303	87-036-215-089		SW, TACT EVQ21404M
C218	87-018-209-089		CAP, TC-U 0.1-50 F	S304	87-036-215-089		SW, TACT EVQ21404M
C401	87-010-384-049		CAP, E 100-25 SME	S305	87-036-215-089		SW, TACT EVQ21404M
C402	87-018-134-089		CAP, TC-U 0.01-16 Y	S306	87-036-215-089		SW, TACT EVQ21404M
C501	87-010-248-049		CAP, E 220-10 SME	S307	87-036-215-089		SW, TACT EVQ21404M
C502	88-018-209-089		CAP, M 0.47	S308	87-036-215-089		SW, TACT EVQ21404M
C503	87-018-198-089		CAP, TC-U 2700P-16 X	S309	87-036-215-089		SW, TACT EVQ21404M
C504	87-018-198-089		CAP, TC-U 2700P-16 X	S310	87-036-215-089		SW, TACT EVQ21404M
C505	88-018-544-049		CAP, M 0.022-50 SME	S311	87-036-215-089		SW, TACT EVQ21404M
C506	88-018-544-049		CAP, M 0.022-50 SME	S312	87-036-215-089		SW, TACT EVQ21404M
C507	87-018-131-089		CAP, TC-U 1000P-50 B	S314	87-036-215-089		SW, TACT EVQ21404M
C508	87-018-131-089		CAP, TC-U 1000P-50 B	S315	87-036-215-089		SW, TACT EVQ21404M
C509	87-010-402-049		CAP, E 2.2-50 SME	S316	87-036-215-089		SW, TACT EVQ21404M
C510	87-010-402-049		CAP, E 2.2-50 SME	S317	87-036-215-089		SW, TACT EVQ21404M
C511	87-018-131-089		CAP, TC-U 1000P-50 B	SFR401	87-024-169-089		SFR, 2.2K DIA6 V
C512	87-018-131-089		CAP, TC-U 1000P-50 B	VR501	82-NK7-615-019		VR, 10KA RK11K1130
C513	87-018-123-089		CAP, TC-U 220P-50 B	VR502	82-NK7-616-019		VR, 10KB RK11K1130(HE, HR)
C514	87-018-123-089		CAP, TC-U 220P-50 B	W102	82-NF7-647-019		CABLE, FFC, 13P-1.25
C515	87-010-545-049		CAP, E 0.22-50 SME	X201	87-008-394-089		CF CST 4.19 MGW
C516	87-018-129-089		CAP, TC-U 680P-50 B	MVR C. B			
C517	87-018-131-089		CAP, TC-U 1000P-50 B	MVR601	82-NF7-676-019		VR, 50KBX2 RK16812 MG
C518	87-018-122-089		CAP, TC-U 180P-50 B	KEY C. B			
C519	87-010-405-049		CAP, E 10-50 SME	S318	87-036-215-089		SW, TACT EVQ21404M
C520	87-010-405-049		CAP, E 10-50 SME	S319	87-036-215-089		SW, TACT EVQ21404M
C521	87-010-401-049		CAP, E 1-50 SME	S320	87-036-215-089		SW, TACT EVQ21404M
C522	87-010-401-049		CAP, E 1-50 SME	S321	87-036-215-089		SW, TACT EVQ21404M
C601	87-018-134-089		CAP, TC-U 0.01-16 Y	S322	87-036-215-089		SW, TACT EVQ21404M
C602	87-018-134-089		CAP, TC-U 0.01-16 Y	AC1 C. B			
C605	87-018-104-089		CAP, TC-U 10P-50 SL		87-033-147-019		CLAMP, FUSE
C606	87-018-104-089		CAP, TC-U 10P-50 SL		82-304-743-019		TERMINAL, 1P
C607	87-010-060-089		CAP, E 100-16 7L		87-035-236-019		FUSE, 1.6A(HR)
C608	87-016-088-049		CAP, E 220-6.3 SR	△ F101	87-035-359-019		FUSE, 500MA 250V T E(K, EE, EZ)
C609	87-018-121-089		CAP, TC-U 150P-50 B	△ F101	87-035-412-019		FUSE, T1.25A 250V UL(U, HE, LH)
C610	87-018-121-089		CAP, TC-U 150P-50 B	△ SW101	87-036-235-019		SW, SL ESD 269(HE, HR, LH)
C611	87-018-199-089		CAP, TC-U 3300P-16 X	AC2 C. B			
C612	87-018-199-089		CAP, TC-U 3300P-16 X	△	82-NF7-622-019		PT, 2NF7 EK(K, EE, EZ)
C613	87-018-121-089		CAP, TC-U 150P-50 B				
C614	87-018-121-089		CAP, TC-U 150P-50 B				
C617	87-018-117-089		CAP, TC-U 68P-50 SL				
C618	87-018-117-089		CAP, TC-U 68P-50 SL				
C621	87-018-196-089		CAP, TC-U 1500P-16 X				
C622	87-018-196-089		CAP, TC-U 1500P-16 X				

REF. NO	PART NO.	カンリ NO.	DESCRIPTION
△	82-NF7-621-019		PT, 2NF7 H<HE, LH>
△	82-NF7-656-019		PT, 2NF7 HR<HR>
△	82-NF7-658-119		PT, 2NF7 U<U>
△	S6-403-020-040		SW, SL R663167
HEAD FLEX C. B<EXCEPT U>			
	S6-201-070-260		HEAD, P-5044BD-24F <EXCEPT U>

■ SPEAKER PARTS LIST

DESCRIPTION で判断できない物は“REFERENCE NAME LIST”を参照してください。
If can't understand for Description please kindly refer to “REFERENCE NAME LIST”.

REF. NO	PART NO.	カンリ NO.	DESCRIPTION
1	83-NSL-001-019		PANEL FR
2	83-NSL-006-019		GRILL FRAME ASSY
3	83-NSL-602-019		SPEAKER WOOFER
4	82-NS5-604-019		SPEAKER TWEETER ASSY
5	83-NS4-610-019		CERAMIC
6	83-NSL-611-019		SPEAKER CORD
7	87-343-172-019		VT+4-12
8	87-342-097-019		VT+3-12

■ ACCESSORIES/PACKAGE LIST

DESCRIPTION で判断できない物は“REFERENCE NAME LIST”を参照してください。
If can't understand for Description please kindly refer to “REFERENCE NAME LIST”.

REF. NO	PART NO.	カンリ NO.	DESCRIPTION
1	83-NFL-905-119		IB, ESF (M) <K, EE, EZ>
1	83-NFL-906-019		IB, ESF (M) <U>
1	83-NFL-907-019		IB, ESF (M) <HE, HR>
1	83-NFL-909-019		IB, ESF (M) <EE, EZ>
1	83-NFL-910-019		IB, ESF (M) -LH <LH>
2	82-NF7-602-019		RC, RC-TN340 EX
3	87-006-268-019		AM LOOP ANT NC<UN>
4	87-009-724-019		PLUG ADPTR, 1R39 <LH>
4	87-009-725-019		PLUG ADPTR, 1R40 <HE, HR>
5	87-043-106-019		FM, WIRE ANT <Z> <K, EE, EZ>
6	87-043-115-01B		ANT, FEEDER FM <U, HE, HR, LH>

BLOCK DIAGRAM - 1 (TUNER : HE, LH, HR, U)

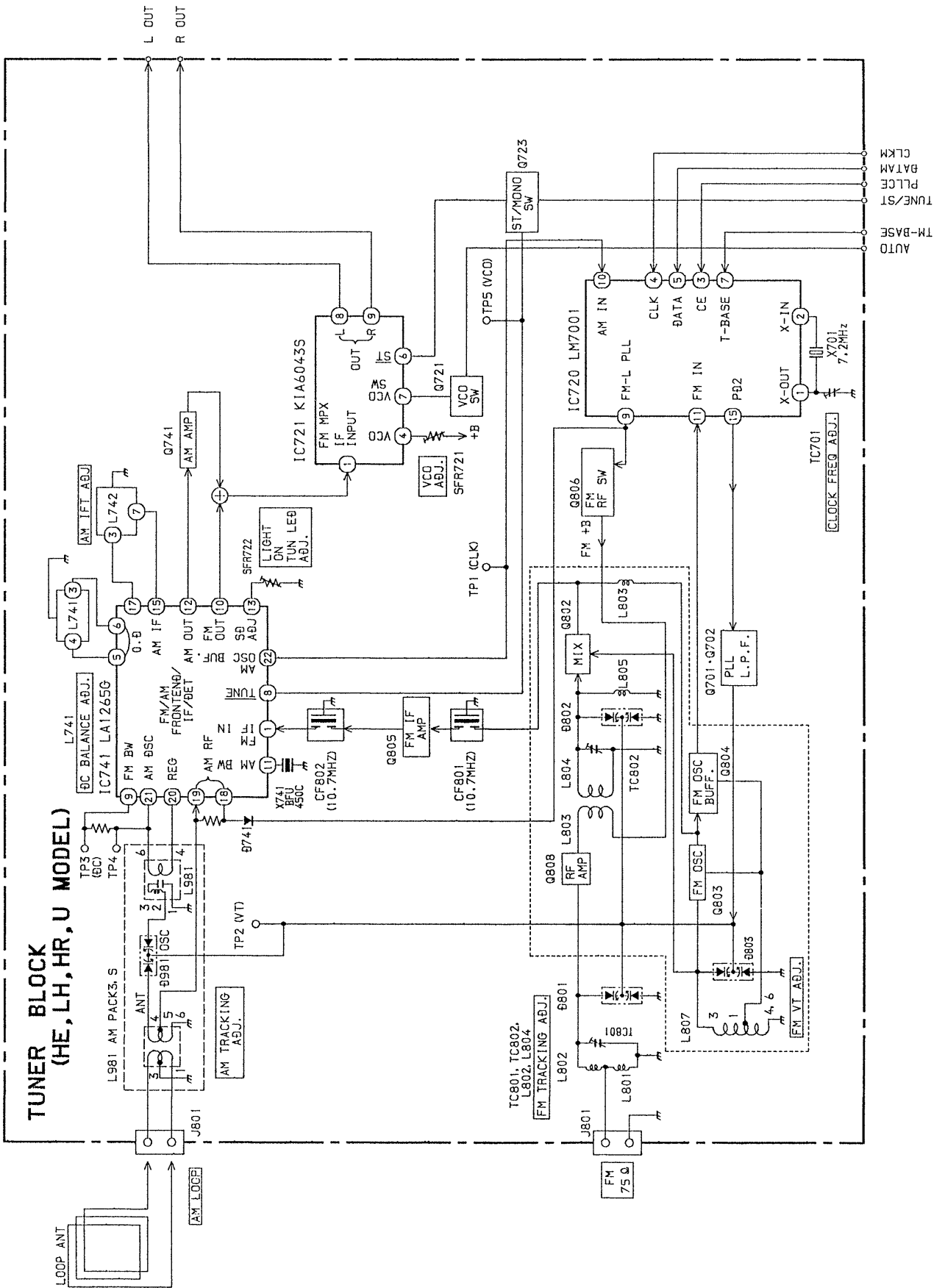

BLOCK DIAGRAM - 2 (TUNER : EE, K, EZ)

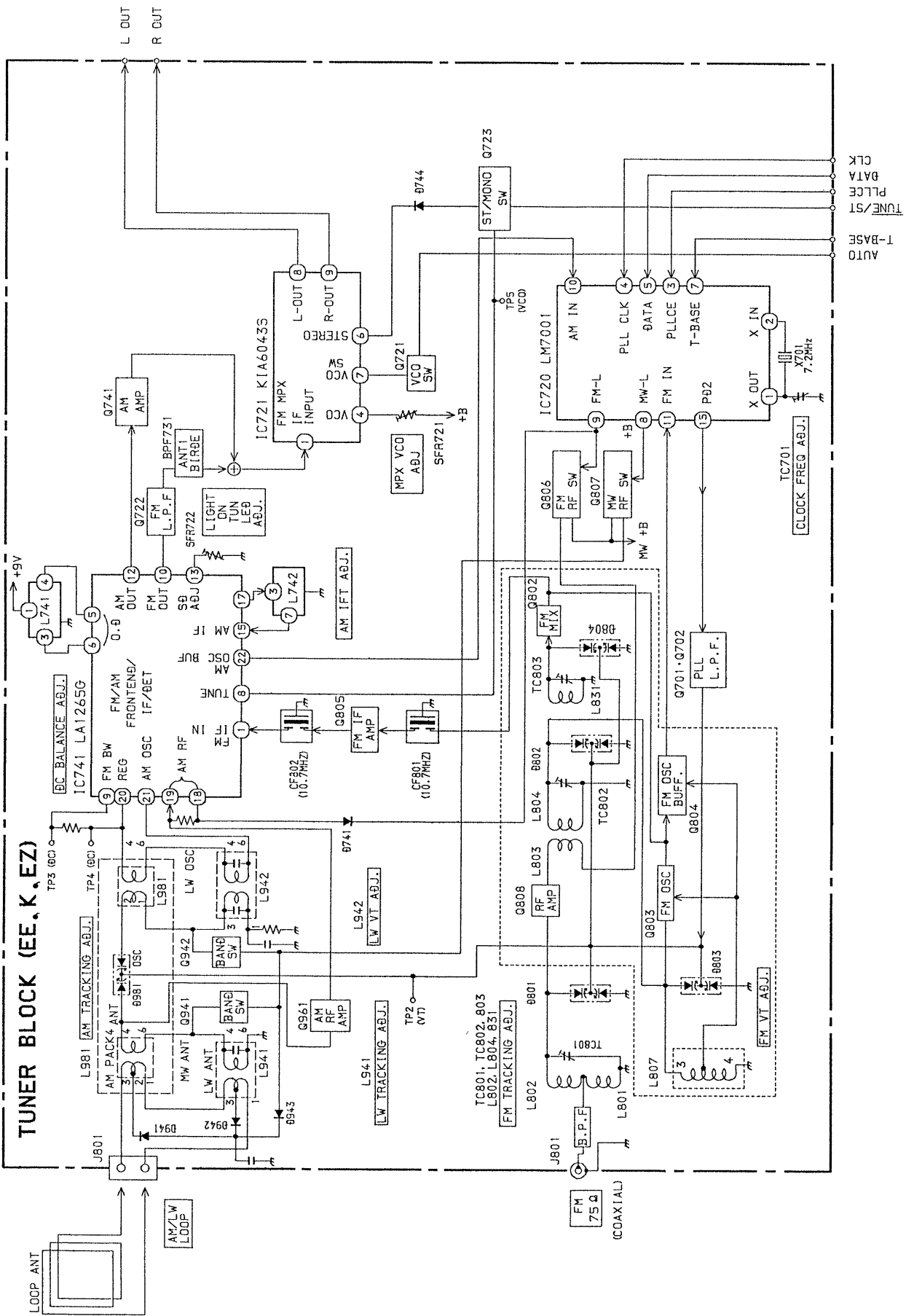

BLOCK DIAGRAM - 3 (MAIN/FRONT)

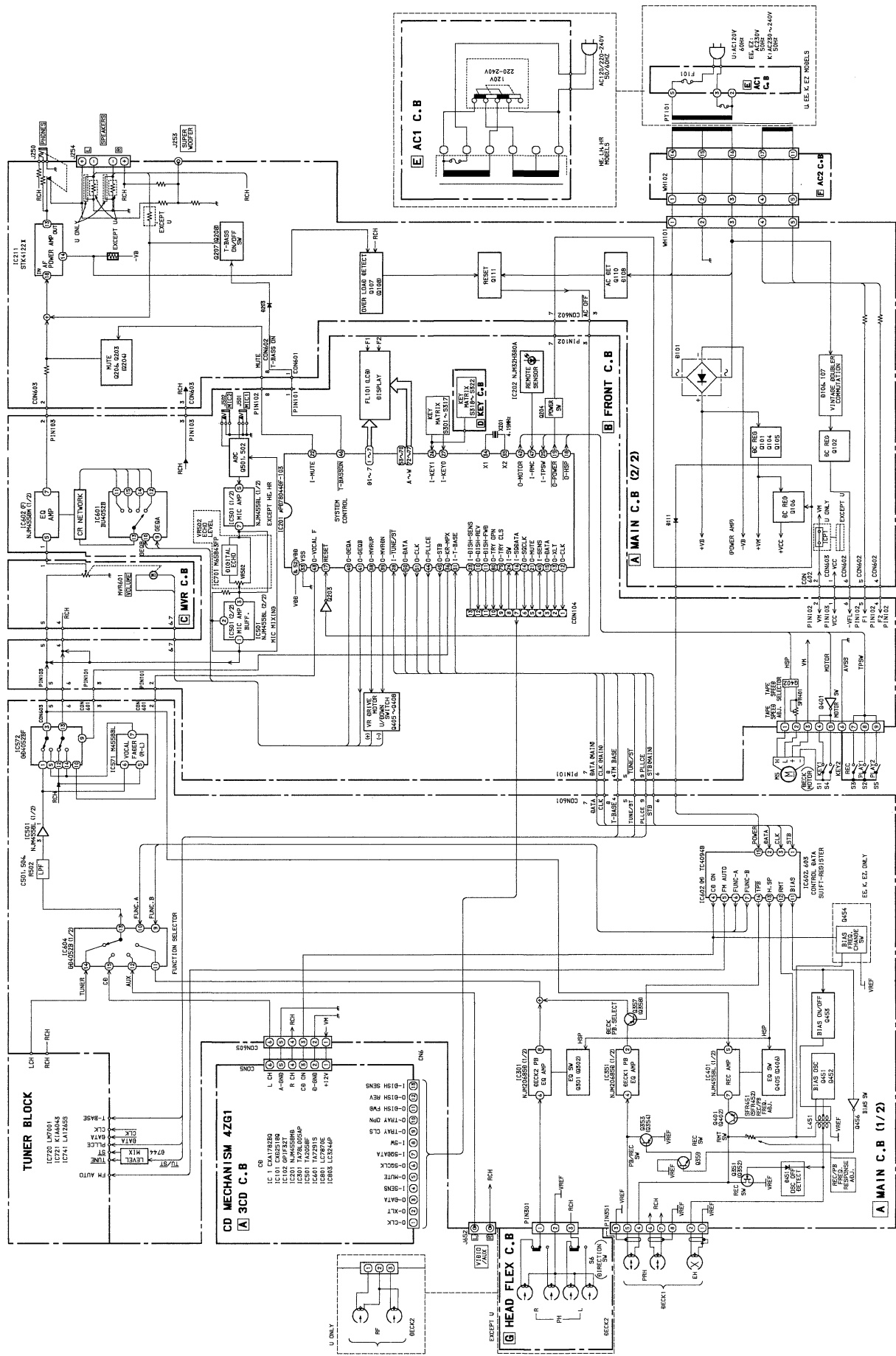

SCHEMATIC DIAGRAM - 1 (MAIN : HE, HR, LH, U)

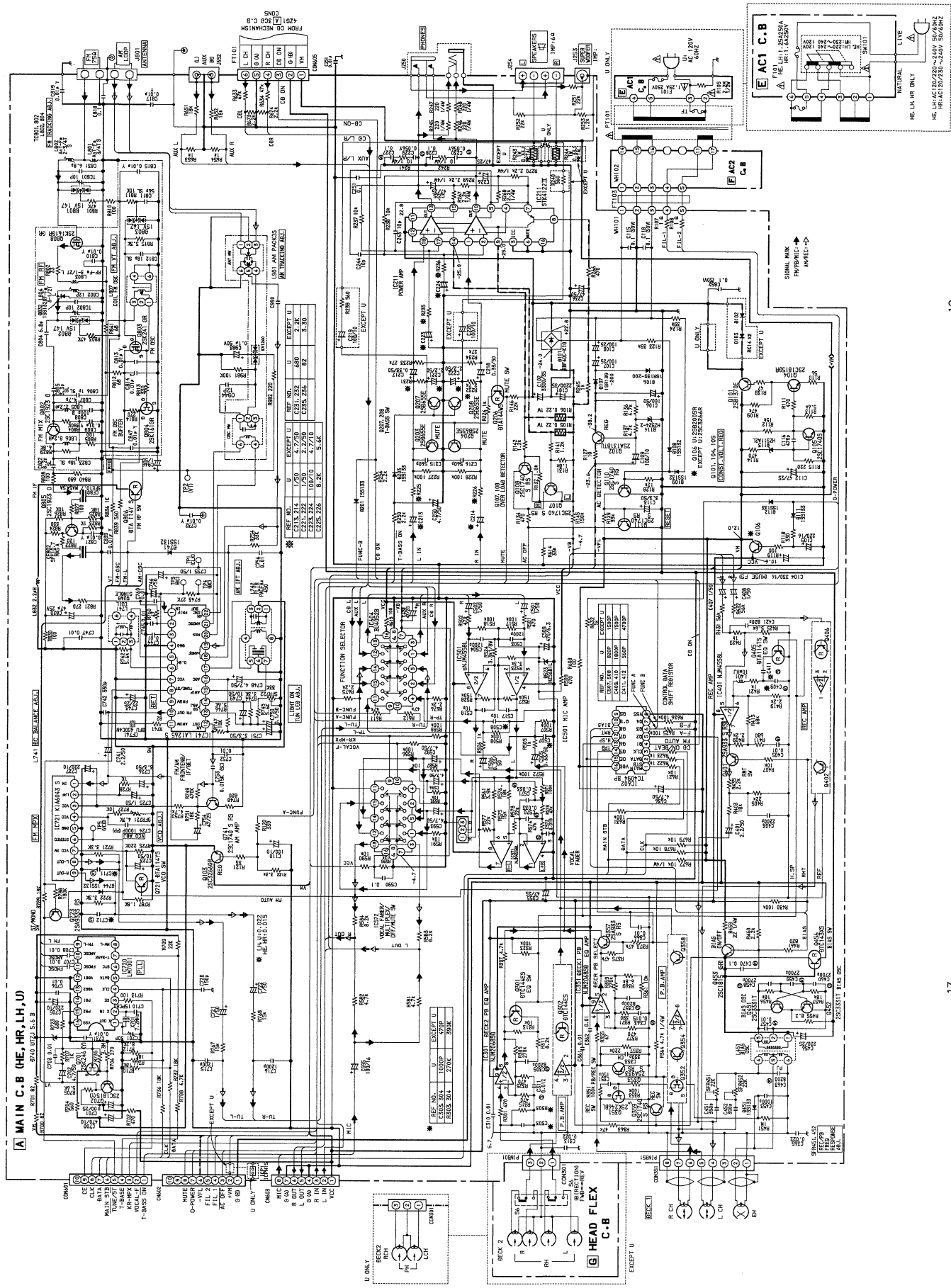

SCHEMATIC DIAGRAM - 2 (MAIN : EE, K, EZ)

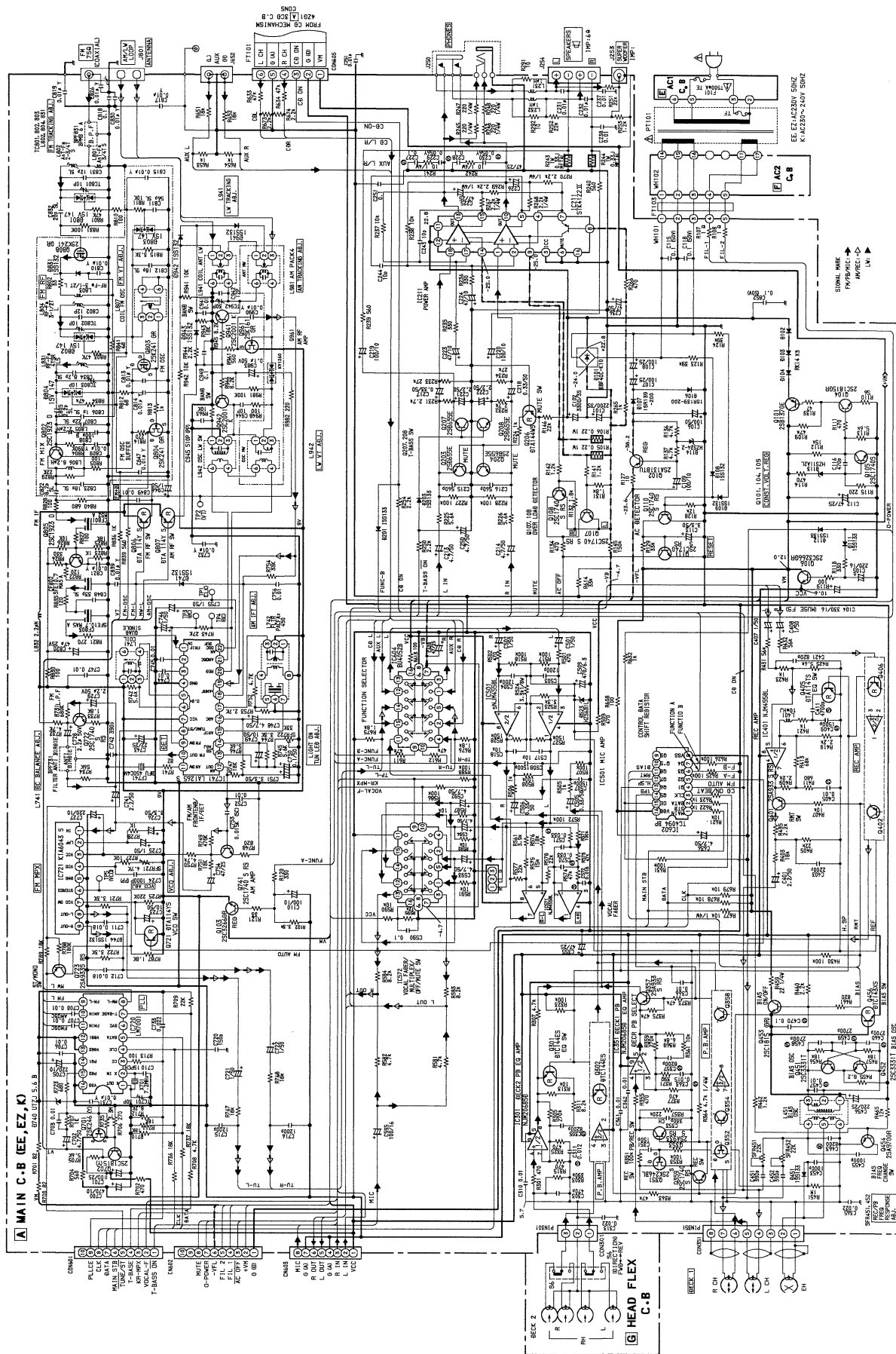

KEY C.B.

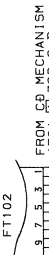
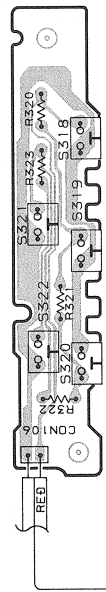

FRONT C.B.

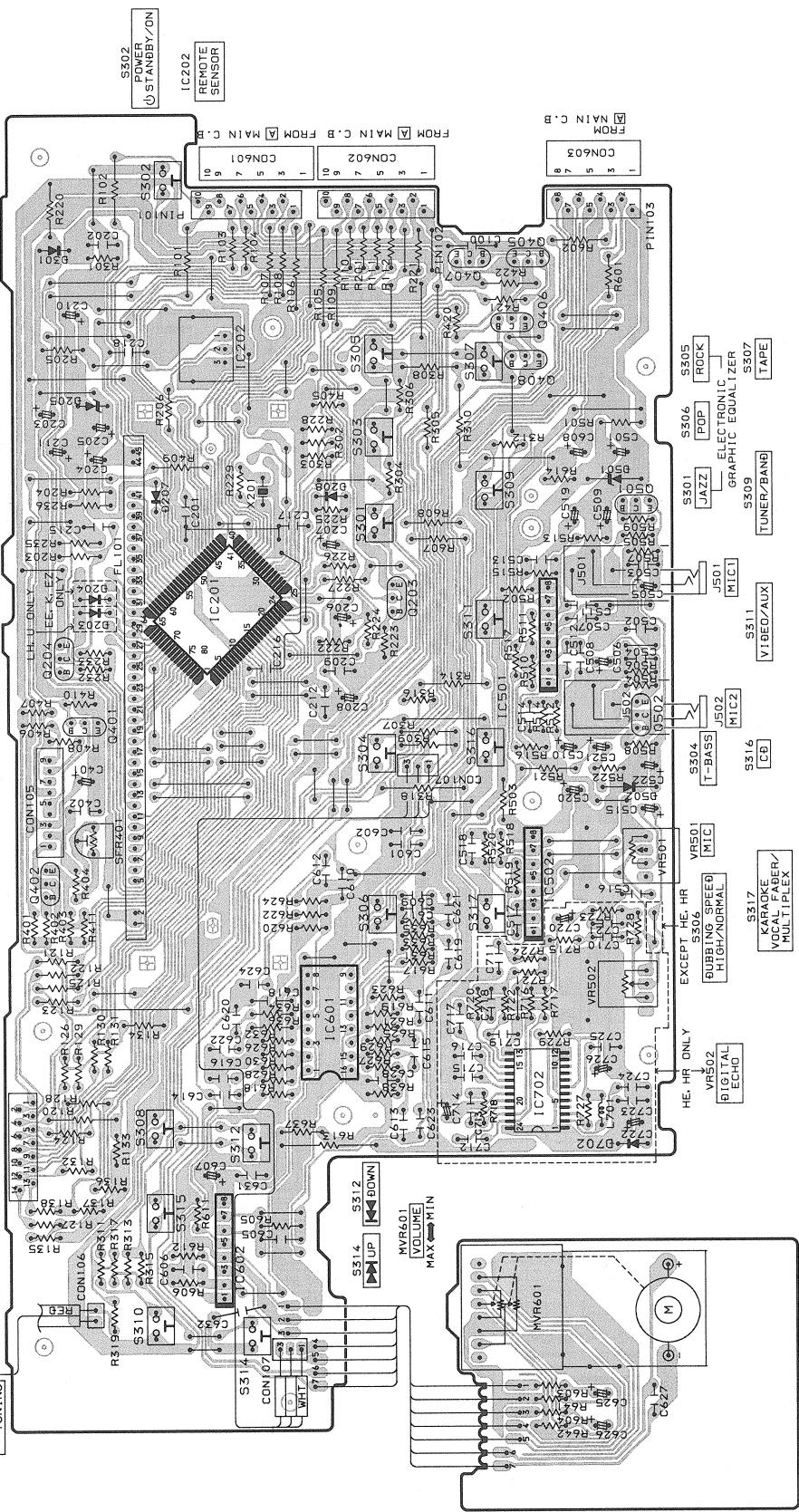

SCHEMATIC DIAGRAM - 3 (FRONT)

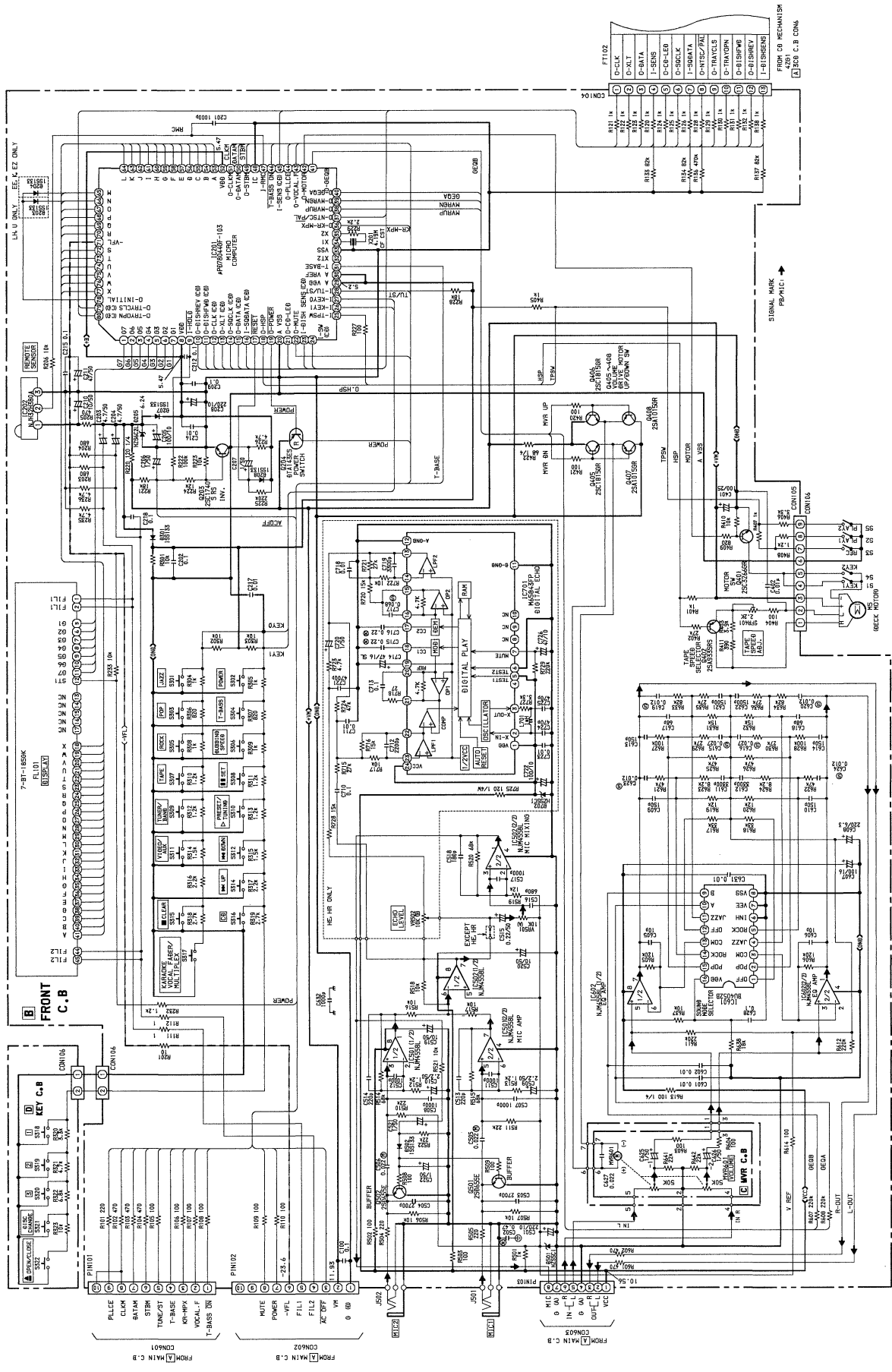

1 2 3 4 5 6 7 8 9 10 11 12 13 14

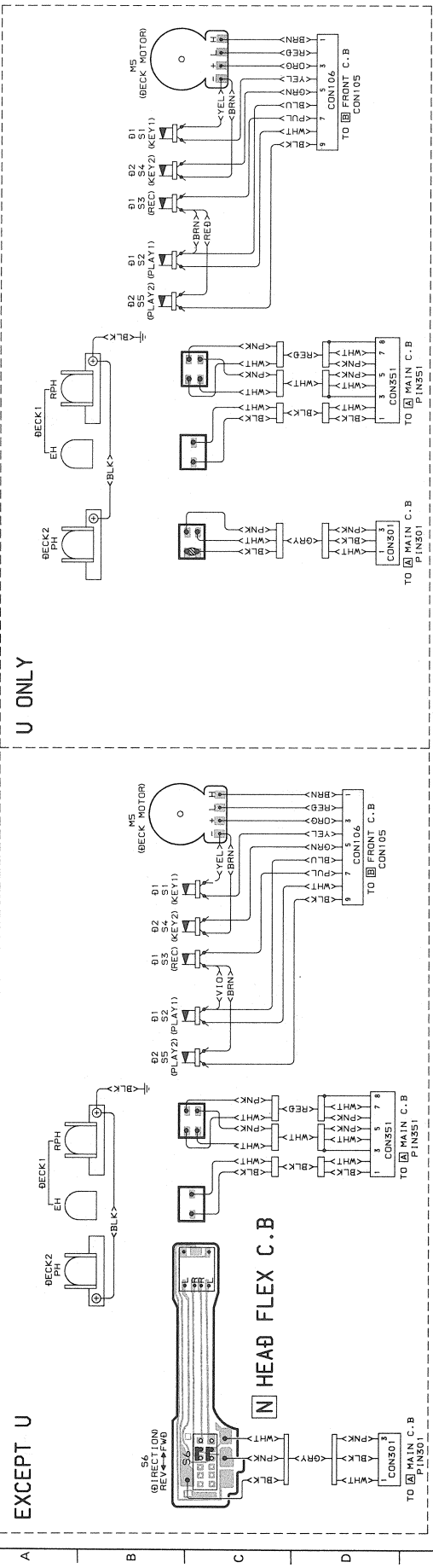

U ONLY

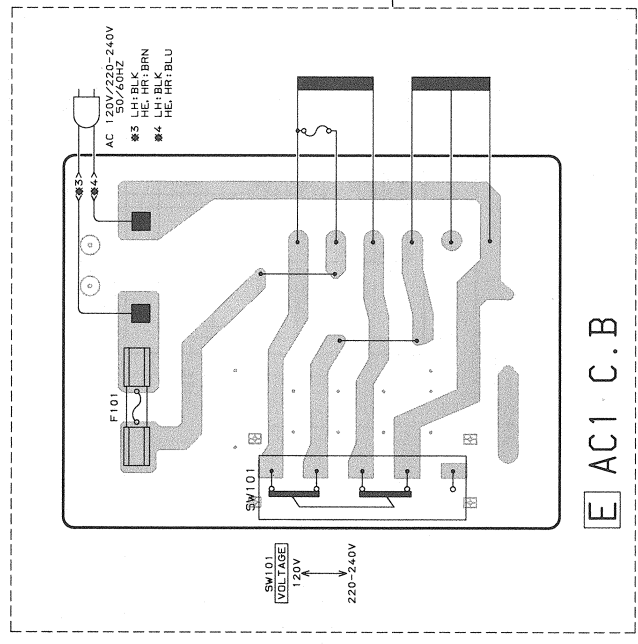
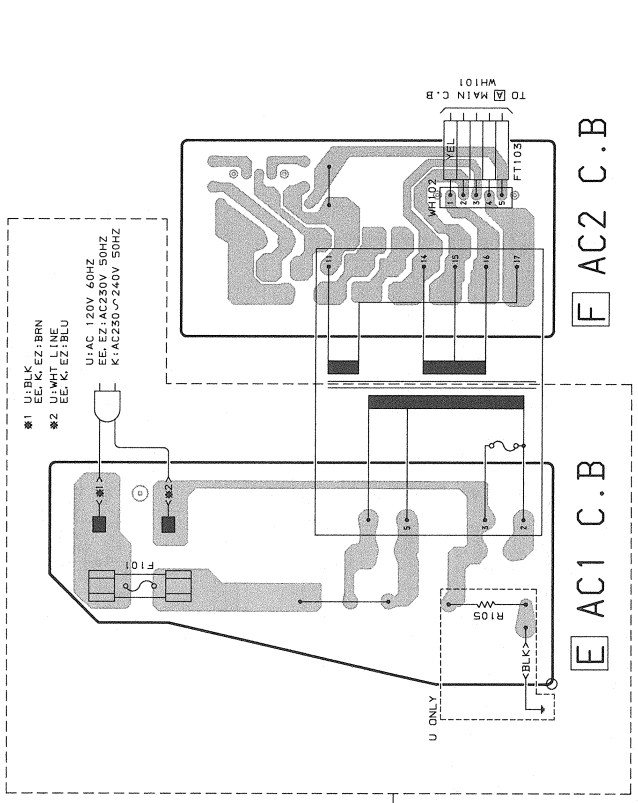

IC BLOCK DIAGRAM

IC, BU4052B

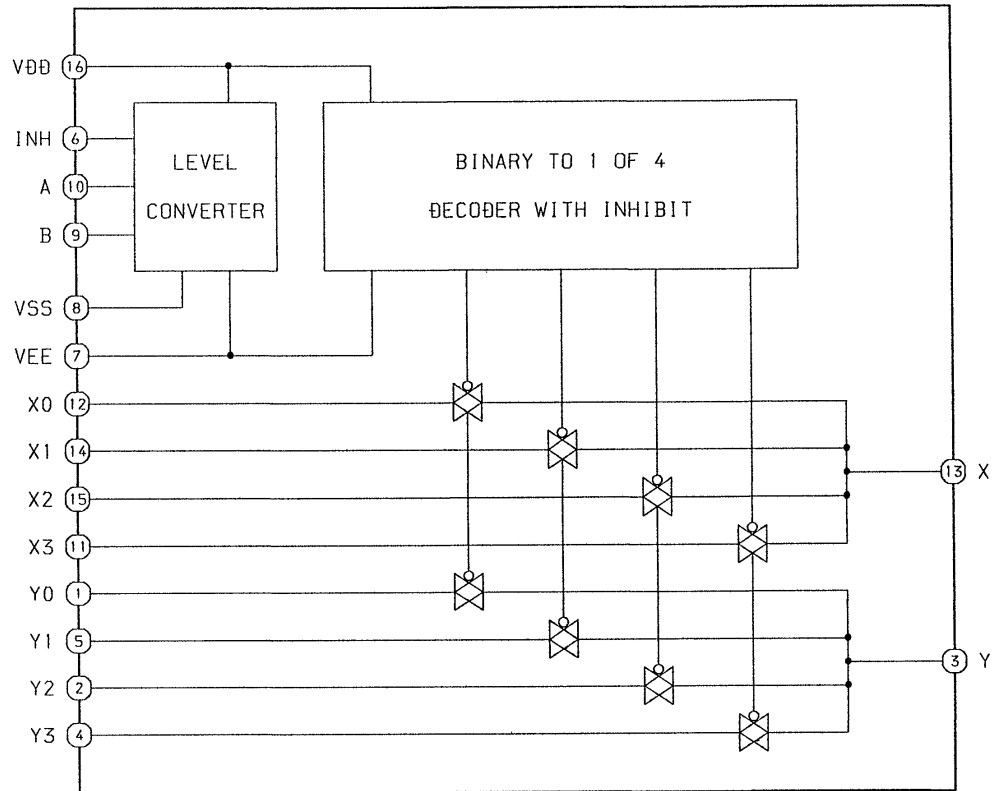

TRUTH TABLE

INHIBIT	A	B	ON SWITCH
L	L	L	X0 Y0
L	H	L	X1 Y1
L	L	H	X2 Y2
L	H	H	X3 Y3
H	X	X	NONE

X: DON'T CARE.

IC, TC4094BP

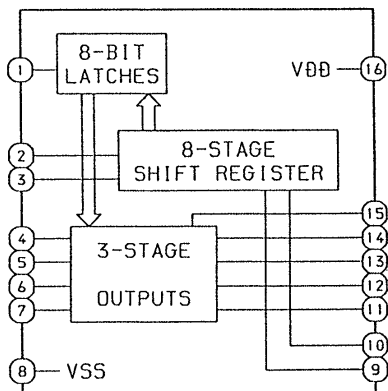

IC, KIA6043S

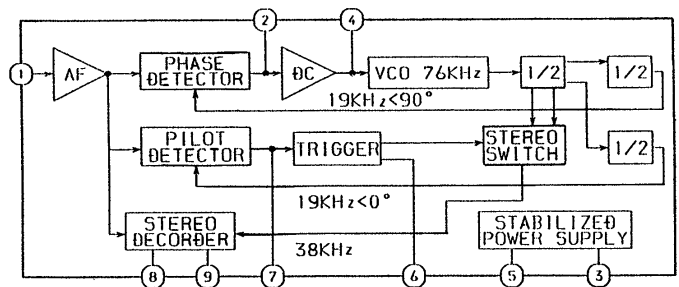

IC, LA1265S

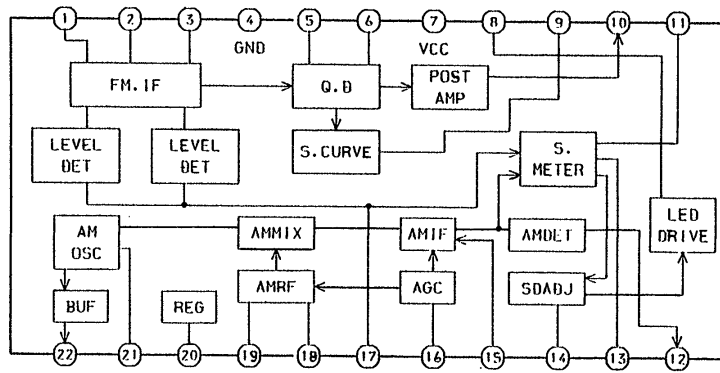

IC, LM7001

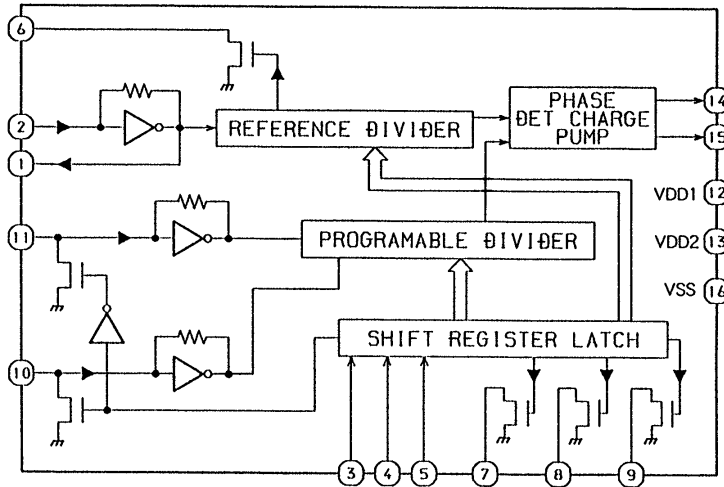

TRANSISTOR ILLUSTRATION



ECB

- 2SA970
- 2SA1015
- 2SA1318
- 2SC1815
- 2SC1923
- 2SC3266
- 2SC3331
- 2SD655



ECB

- 2SA933S
- 2SC1740S
- DTA114TS
- DTA114YS
- DTA143ES
- DTA144ES
- DTA144WS
- DTC114YS
- DTC143XS
- 2SC1815Y
- 2SC2001K



DGS

- 2SK161
- 2SK241

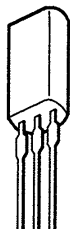

SGD
2SK246

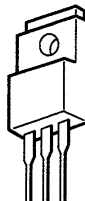

BCE
2SB1370

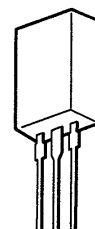

BCE
2SD2005R

FL (7 - BT - 185GK) GRID ASSIGNMENT / ANODE CONNECTION

GRID ASSIGNMENT

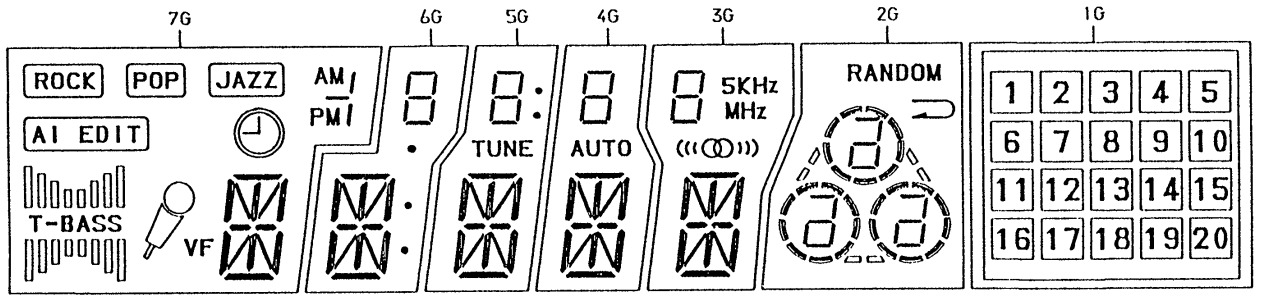

SEGMENT DESIGNATION

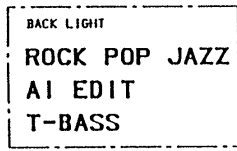

(7G)

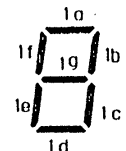

(6G ~ 3G)

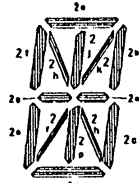

(7G ~ 3G)

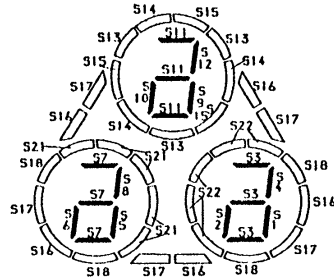

(2G)

ANODE CONNECTION

	7G	6G	5G	4G	3G	2G	1G
A	2d	2d	2d	2d	2d	S1	20
B	2j, 2p	2j, 2p	2j, 2p	2j, 2p	2j, 2p	S2	19
C	2n	2n	2n	2n	2n	S3	18
D	2r	2r	2r	2r	2r	S4	17
E	2c	2c	2c	2c	2c	S5	16
F	2o	2o	2o	2o	2o	S6	15
G	2m	2m	2m	2m	2m	S7	14
H	2q	2q	2q	2q	2q	S8	13
I	2f	2f	2f	2f	2f	S9	12
J	2b	2b	2b	2b	2b	S10	11
K	2k	2k	2k	2k	2k	S11	10
L	2h	2h	2h	2h	2h	S12	9
M	2a	2a	2a	2a	2a	S13	8
N		o	TUNE	AUTO	(((O)))	S14	7
O		o	o (DOWN)	—	MHz	S15	6
P	(AI EDIT)	—	o (UP)	—	KHz	S16	5
Q		—	—	—	5	S17	4
R	PM	1d	1d	1d	1d	S18	3
S	—	1e	1e	1e	1e	—	2
T	/	1c	1c	1c	1c	—	1
U	AM	1a	1a	1a	1a	S21	—
V	(JAZZ)	1f	1f	1f	1f	S22	—
W	(POP)	1b	1b	1b	1b		—
X	(ROCK)	1a	1a	1a	1a	RANDOM	—
ST1	BACK LIGHT	—	—	—	—	—	

IC DESCRIPTION

IC, μ PD78044GF-103

Pin No.	Pin Name	I/O	Description
1~7	G7~G1	O	FL display digit output
8	VDD	—	Connected to +5.5V
9	$\overline{\text{I-HOLD}}$	I	When AC main power is turned off, input goes L which puts μ processor into HOLD mode. (Clock is stopped and memory is backed up.)
10	O-DISH RVS	O	Turn-table reverse direction output
11	O-DISH FWD	O	Turn-table forward direction output
12	O-CLK	O	CD control output
13	O-XLT	O	CD control output
14	O-SQCLK	O	CD control output
15	O-DATA	O	CD control output (serial data)
16	I-SQDATA	I	CD control output
17	$\overline{\text{RESET}}$	—	Reset input
18	O-HSP	O	Deck motor speed control. Double speed when "H" (12V) is input.
19	$\overline{\text{O-POWER}}$	O	Power ON/OFF control. Power is turned OFF when "H" (12V) is input.
20	A VSS	—	Connected to GND
21	O-CD-LED	O	CD-LED ON signal
22	O-MUTE	O	Mute output
23	I-DISH SENS	I	CD turn-table signal
24	I-SW	I	CD tray OPEN/CLOSE, and mechanism UP/DOWN signal input
25	I-TPSW	I	Deck PLAY, REC mechanism signal
26	I-KEY1	I	Key data input 1
27	I-KEY0	I	Key data input 0
28	I-TU/ST	I	Signal input during tuner reception and stereo reception
29	A VDD	—	Connected to +5V
30	A VREF	—	Connected to +5V
31	I-TMBASE	I	Dynamic reference clock (50/60 Hz)
32	XT2	—	Sub-clock connector (not used)
33	VSS	—	Connected to GND
34	X1	—	4.19 MHz oscillator circuit
35	X2	—	4.19 MHz oscillator circuit
36	O-KR-MPX	O	KARAOKE multiplex ON/OFF control. Multiplex is ON when "H" (+5V) is input.
37	$\overline{\text{NTSC/PAL}}$	O	CD graphic control signal. NTSC mode when "H" (+5V) is input.
38	O-MVRUP	O	Motor UP control signal from manual volume control
39	O-MVRDN	O	Motor DOWN control signal from manual volume control
40	O-GEQA	O	Graphic equalizer control signal
41	O-GEQB	O	Graphic equalizer control signal
42	O-MOTOR	O	Deck motor ON/OFF control output. (ON state in 4 seconds after Power ON.)
43	O-VOCAL F	O	Vocal fader ON/OFF control output. Vocal fader ON when "H" (+5V) is input.
44	O-PLLCE	O	Chip enable output to tuner PLL IC LM7001
45	I-SENS	I	CD tray position sensor input signal
46	$\overline{\text{T-BASS ON}}$	O	T-BASS ON/OFF control T-BASS is ON when "L" is input.

Pin No.	Pin Name	I/O	Description
47	I-RMC	I	Remote control signal
48	IC	—	Connected to GND
49	O-STBM	O	Strobe signal of the shift register IC602 (4094) on the MAIN board
50	O-DATAM	O	Serial data of the PLL IC720 (LM7001) and IC602 (4094) on the MAIN board
51	O-CLKM	O	Serial clock of the PLL IC720 (LM7001) and IC602 (4094) on the MAIN board
52	VDD	—	Connected to +5V
53~66	A~N	O	FL display segment output
67,68	O,P	I/O	FL display segment output. Initializing scan
69,70	Q,R	O	FL display segment output
71	-VFL	—	Power supply for FL display (-23V)
72~77	S~X	O	FL display segment output
78	O-INITIAL	O	μprocessor initializing control
79	O-TRY $\overline{\text{OPN}}$	O	CD tray OPEN control. OPEN when "L" is input
80	O-TRY $\overline{\text{CLS}}$	O	CD tray CLOSE control CLOSE when "L" is input

6. LW Tracking Adjustment (EE,K,EZ)
 Settings : • Test point : TP6
 • Adjustment location :
 L941 144kHz
 TC942 290kHz
 Method : Set up TC942 to center before adjustment.
 The level at 144kHz is adjusted to MAX
 by L941. Then the level at 290kHz is done
 by TC942.
7. FM VT Adjustment
 Settings : • Test point : TP2 (VT)
 • Adjustment location : L807
 Method : Set to FM 87.5MHz and adjust L807 so
 that the test point becomes $2.90V \pm 0.05V$.
8. FM Tracking Adjustment
 Settings : • Test point : TP6
 TC801, TC802, TC803 (EE,K,EZ) 108MHz
 L802, L804, L831 (EE,K,EZ) 87.5MHz
9. DC Balance/MONO Distortion Adjustment
 Settings : • Test point : TP3, TP4 (DC balance)
 TP6 (Distortion)
 • Adjustment location : L741
 • Input level : 54dB
 Method : Set to FM 98.0MHz and adjust L741 so
 that the voltage between TP3 and TP4
 becomes $0V \pm 0.02V$. Next check that the
 distortion becomes less than 0.9%.
10. MPX VCO Adjustment
 Settings : • Test point : TP5 (IC721 pin 6)
 • SSG : modulation OFF
 • Adjustment location : SFR721
 • Input level : 54dB
 Method : Connect a capacitor and a resistor as
 below. Set to FM 98.0MHz and adjust
 SFR721 so that the frequency at test point
 becomes $38kHz \pm 0.05kHz$.

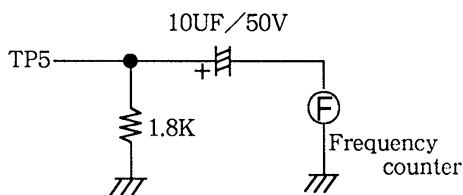

11. Light on Tuning LED Adjustment
 Settings : • Adjustment location : SFR722
 • Input level : 16dB
 Method : Set to FM 98.0MHz and adjust TUNING
 LED to light on by SFR722. After that
 LED goes out by 2dB down.

< TAPE SECTION >

12. Tape Speed Adjustment
 Settings : • Test tape : TTA-100
 • Test point : TP6
 • Adjustment location : SFR401
 Method : Play back the test tape, adjust SFR401
 for $3000Hz \pm 10Hz$.
13. Head Azimuth Adjustment (DECK1, DECK2)
 Settings : • Test tape : TTA-330
 • Test point : TP6
 • Adjustment location : Head azimuth
 adjustment screw
 Method : Play back the 10kHz signal of the test tape
 and adjust so that the output becomes
 maximum.
14. REC/PB Frequency Response Adjustment (DECK1)
 Settings : • Test tape : TTA-601
 • Test point : TP6
 • Input signal : 1kHz/10kHz (AUX-28dB)
 • Adjustment location : SFR451 (Lch)
 SFR452 (Rch)
 Method : Record and play back the 1kHz and 10kHz
 signals and adjust so that the TP6 level
 of the 10kHz signal is $0dB \pm 0.5dB$ with
 respect to that of the 1kHz signal.

PRACTICAL SERVICE FIGURE

TUNER SECTION

FM SECTION

IHF Sensitivity : < EXCEPT LH,U >
10dB ± 5dB (87.5MHz)
(THD 3%) 8dB ± 5dB (98.0MHz)
8dB ± 5dB (108.0MHz)
< LH,U >
6dB ± 5dB (87.5MHz)
5dB ± 5dB (98.0MHz)
5dB ± 5dB (108.0MHz)

S/N 50dB Quieting sensitivity :
32dB ± 5dB
(87.5/98.0/108.0MHz)

Signal to noise ratio : More than 72dB (98.0MHz)
Distortion : Less than 0.9% (98.0MHz)
Stereo separation : More than 25dB (98.0MHz)
Intermediate frequency : 10.7MHz

MW SECTION

Sensitivity : < EXCEPT LH,U >
54dB + 8dB, - 6dB (603kHz)
(S/N 20dB) 53dB ± 6dB (999kHz)
53dB ± 6dB (1404kHz)
< LH,U >
54dB + 8dB, - 6dB (600kHz)
53dB ± 6dB (1000kHz)
53dB ± 6dB (1400kHz)
Distortion : < EXCEPT LH,U >
Less than 1.5% (999kHz)
< LH,U >
Less than 1.5% (1000kHz)
Intermediate frequency : 450kHz

LW SECTION < EE,K,EZ >

Sensitivity : 66dB ± 5dB (144kHz)
(S/N 20dB) 63dB ± 5dB (198kHz)
62dB ± 5dB (290kHz)
Distortion : Less than 1.5% (198kHz)
Intermediate frequency : 450kHz

TAPE SECTION

Tape speed : 3000Hz ± 3.0%
Wow & flutter : Less than 0.4%
(R.M.S)
Take-up torque : 30~60g-cm (FWD, REV)
F.F torque : 55~140g-cm
Rew torque : 55~140g-cm
Back tension : 2~5g-cm
PB Output level : 3.0V ± 1.5dB (SP OUT)
REC/PB Output level : 2.0V ± 2.0dB (SP OUT)
Distortion (REC/PB) : Less than 2% (NORM)
Noise level (PB) : Less than 140mV
(NORM, Vol MAX.)
Noise level (REC/PB) : Less than 35mV
(NORM, SP OUT, Vol 2V)
Crosstalk : More than 55dB (1kHz, 0VU)
Erasing ratio : More than 55dB (125Hz)
Channel separation : More than 38dB (1kHz, 0VU)
REC bias frequency : 85kHz
Test tape : NORMAL TTA - 601

A 3CD C.B

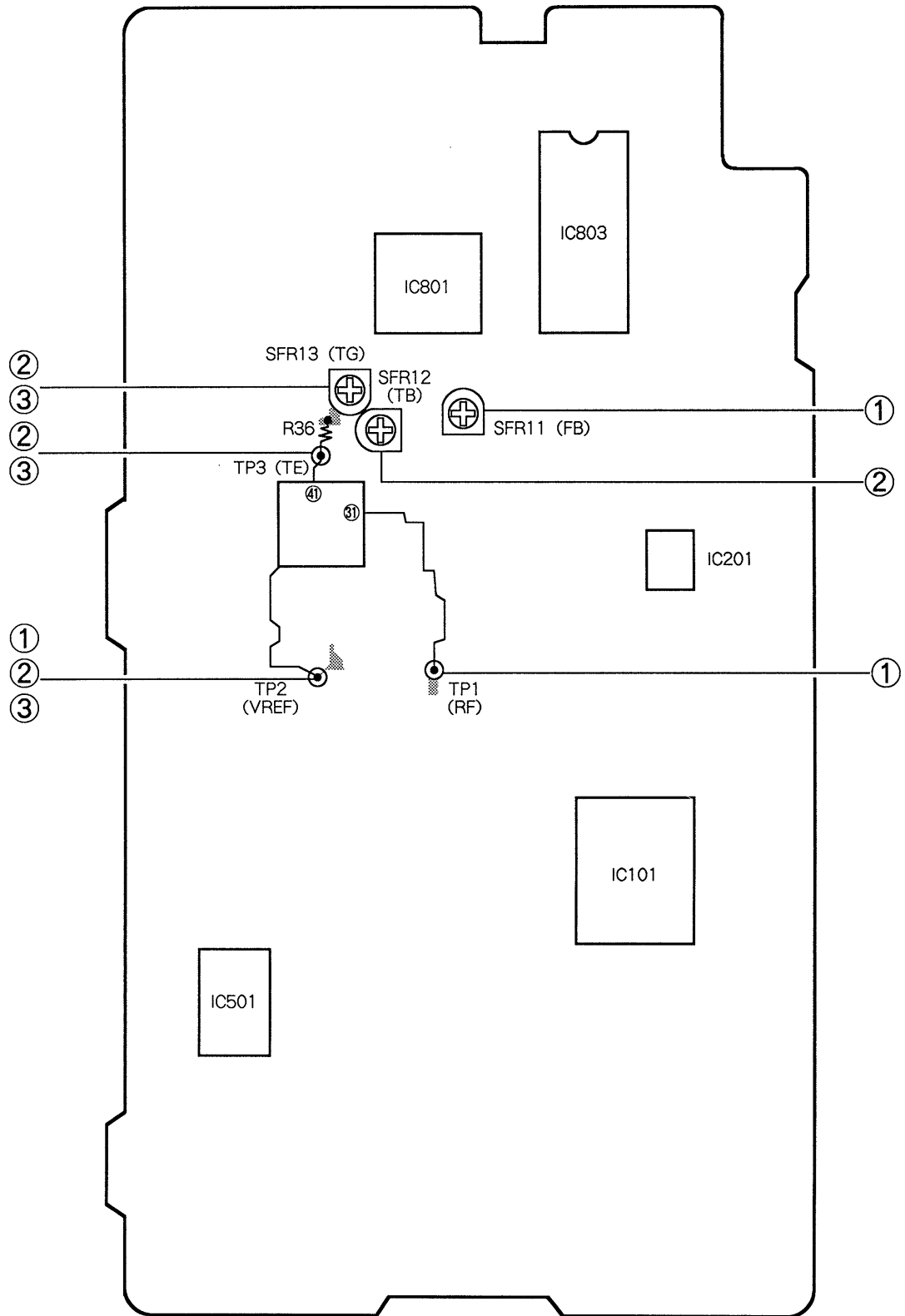

Note: Connect a probe (10: 1) of the oscilloscope or the frequency counter to a test point.

1. Focus Bias Adjustment

Make the focus bias adjustment when replacing and repairing the optical block.

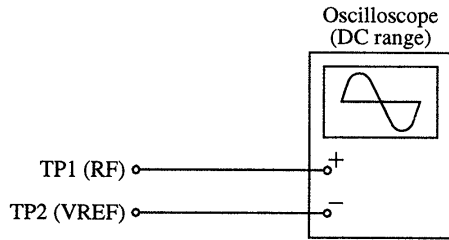

- 1) Connect an oscilloscope to test points TP1 (RF) and TP2 (VREF).
- 2) Turn on the power switch.
- 3) Insert test disc TCD-782 (YEDS-18) and play back the second composition.
- 4) Adjust SFR11 so that RF signal of test point TP1 (RF) is MAX and CLEARREST.

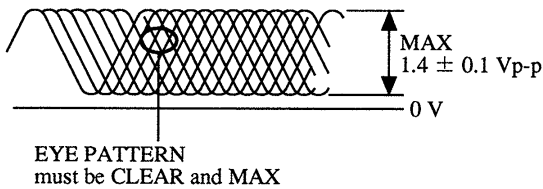

VOLT/DIV : 0.5 V
TIME/DIV : 1 μ S

Note: The current of the laser signal can be checked with the voltages on both sides of R28 (10Ω). The difference for the specified value shown on the level must be within ± 6.0mA.

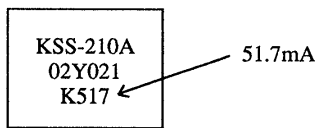

$$\text{Laser current } I_{op} = \frac{\text{Voltage across R28}}{10\Omega}$$

2. Tracking Balance Adjustment

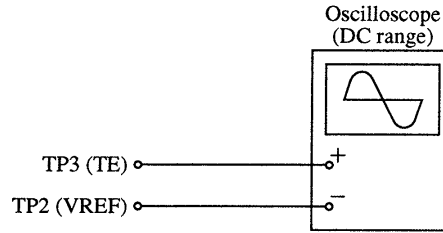

- 1) Connect an oscilloscope to test points TP3 (TE) and TP2 (VREF).
- 2) Turn on the power switch.
- 3) Insert test disc TCD-782 (YEDS-18) and press the PLAY button.
- 4) Connect the intermediate point of SFR13 to TP2 (VREF).
- 5) Adjust SFR12 so that the waveform on the oscilloscope is vertically symmetrical as shown in the figure below.
- 6) After the adjustment is completed, remove the connected lead wires from the terminals.

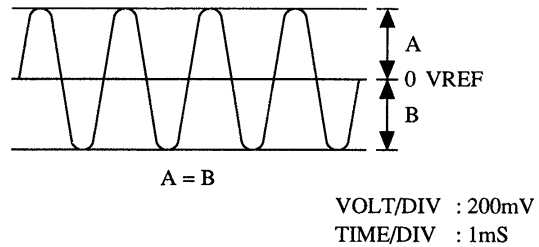

3. Tracking Gain Adjustment

A servo analyzer is necessary in order to perform this adjustment exactly. However, this gain has a margin, so even if it is slightly off, there is no problem. Therefore, do not perform this adjustment.

Focus/tracking gain determines the pick-up follow-up (vertical and horizontal) relative to mechanical noise and mechanical shock when 2-axis device operates. However, as these reciprocate, the adjustment is at the point where both are satisfied.

- When gain is raised, the noise increases when the 2-axis device operates.
- When gain is lowered, it is more susceptible to mechanical shock and skipping occurs more easily.

When the gain adjustment is off, the symptoms below appear.

Symptoms \ Gain	(Focus)	Tracking
● The time until music starts becomes longer for STOP → PLAY or automatic selection (◀▶ buttons pressed.) (Normally takes about 2 seconds.)	low	low or high
● Music does not start and disc continues to rotate for STOP → PLAY or automatic selection (◀▶ buttons pressed.)	—	low
● Disc stops to rotate shortly after STOP → PLAY.	low or high	—
● Sound is interrupted during PLAY. Or time counter display stops.	—	low
● More noises during the 2-axis device operation.	high	high

The following is simple adjustment method.

— Simple adjustment —

Note: Since the exact adjustment cannot be performed, remember the positions of the controls before the performing the adjustment. If the positions after the simple adjustment are only a little different, return the controls to the original position.

Procedure:

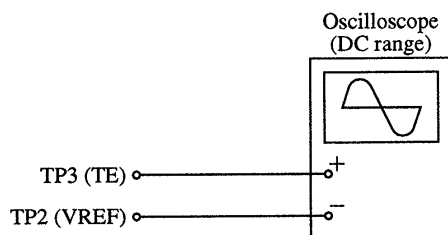

- 1) Keep the set horizontal. (If the set is not kept horizontally, this adjustment cannot be performed due to the gravity against the 2-axis device.)
- 2) Insert test disc TCD-782 (YEDS-18) and play back the second composition.
- 3) Connect an oscilloscope to TP3 (TE), TP2 (VREF) of the CD C.B.
- 4) Adjust SFR13 so that the waveform appears as shown in the figure below. (tracking gain adjustment)

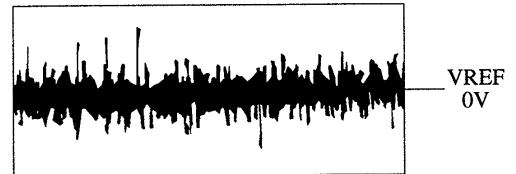

VOLT/DIV: 50 mV
TIME/DIV: 1 mS

- Incorrect example

Low tracking gain

The fundamental wave appears as compared with the waveform adjusted.

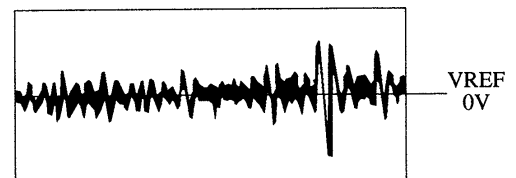

VOLT/DIV: 50 mV
TIME/DIV: 1 mS

High tracking gain

The frequency of the fundamental wave is higher than that in low gain.

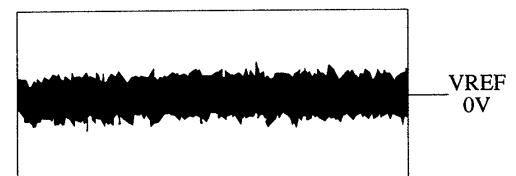

VOLT/DIV: 50 mV
TIME/DIV: 1 mS

MECHANICAL EXPLODED VIEW 1/1

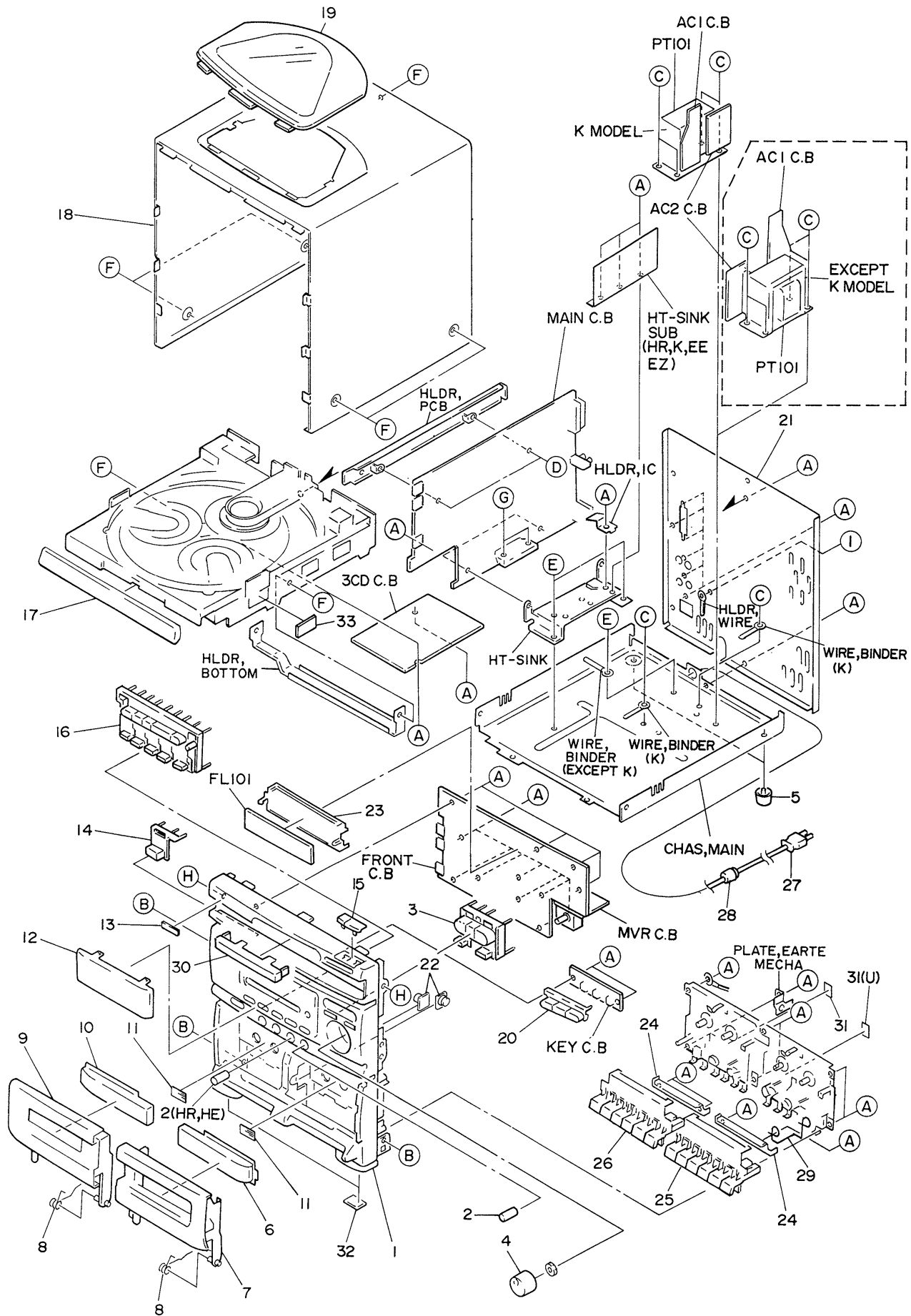

MECHANICAL PARTS LIST 1/1

DESCRIPTIONで判断できない物は“REFERENCE NAME LIST”を参照してください。
 If can't understand for Description please kindly refer to “REFERENCE NAME LIST”.

REF. NO	PART NO.	カン NO.	DESCRIPTION	REF. NO	PART NO.	カン NO.	DESCRIPTION
1	83-NFL-049-019		CAB, FR EZ<(K, EE, EZ)>	23	82-NF7-210-019		GUIDE, FL
1	83-NFL-032-019		CAB, FR HE<(HE, HR)>	24	82-NF7-204-019		HLDR, KEY
1	83-NFL-033-019		CAB, FR LH<(LH)>	25	83-NFL-018-019		KEY, CASS 1W<(U)>
1	83-NFL-001-019		CAB, FR U<(U)>	25	83-NFL-016-019		KEY, CASS RVS<(EXCEPT U)>
2	83-NF6-020-019		KNOB, MIC	26	83-NFL-017-019		KEY, CASS REC
3	83-NFL-009-019		KEY, PLAY	△	27 87-050-032-019		AC CORD ASSY K 3P S<(K)>
4	83-NFL-043-019		KNOB, VOL M	△	27 87-050-034-019		AC CORD ASSY, E<(HE, HR, EE, EZ)>
5	87-085-221-019		FOOT, H 13.5	△	27 87-050-097-019		AC CORD ASSY, H<(LH)>
6	83-NFL-015-019		WINDOW, BOX 2	△	27 87-050-053-019		AC CORD ASSY, U-2<(U)>
7	83-NFL-004-019		BOX, CASS 2<(U)>	28	87-085-184-010		BUSHING, AC CORD D<(LH)>
7	83-NFL-035-019		BOX, CASS 2R<(HE, HR, LH)>	28	87-085-185-010		BUSHING, AC CORD E<(EXCEPT U, LH)>
7	83-NFL-048-019		BOX, CASS 2RE<(K, EE, EZ)>	28	87-085-189-019		BUSHING, CORD U<(U)>
8	82-NF7-218-019		SPR-T, CASS	29	82-NF7-217-019		SPR-T, EARTH
9	83-NFL-003-019		BOX, CASS 1<(HE, HR, LH)>	30	83-NFL-013-019		WINDOW, CD
9	83-NFL-047-019		BOX, CASS 1UE<(U, K, EE, EZ)>	31	81-584-246-019		MYLAR 5-10
10	83-NFL-014-019		WINDOW, BOX 1	32	80-VT1-202-019		FELT, 12.5-15.5-2
11	81-532-080-019		LBL, CASS-COMPT	33	80-MQ1-209-019		CLOTH, 20-7
12	83-NFL-012-019		WINDOW, DISPLAY	A	87-067-703-019		BVT2+3-10 (W/O SLOT)
13	82-NE6-067-019		BADGE AIWA 30N	B	87-591-094-419		QIT+3-6 GOLD
14	83-NFL-008-019		KEY, POWER	C	87-078-019-019		S-SCREW, IT+4-6
15	83-NFL-006-119		KEY, OPEN	D	87-067-689-019		BVTT+3-8
16	83-NFL-010-019		KEY, FUNCTION	E	87-067-688-019		BVTT +3-6
17	83-NFL-005-019		PANEL, TRAY<(HE, HR, LH)>	F	87-067-641-019		UTT2+3-8 W/O SLOT BLK
17	83-NFL-046-019		PANEL, TRAY UE<(U, K, EE, EZ)>	G	87-067-698-019		BVT 2+3-18 (W/O SLOT)
18	83-NFL-045-119		CAB, STEEL S	H	87-721-097-419		QT2+3-12 GLD
19	83-NF5-021-019		WINDOW, TOP	I	87-084-077-010		NYLON RIVET
20	83-NFL-007-019		KEY, CD				
21	83-NFL-025-019		PANEL, REAR EEBNM<(EE)>				
21	83-NFL-026-019		PANEL, REAR EZBNM<(EZ)>				
21	83-NFL-022-019		PANEL, REAR HEJBNM<(HE)>				
21	83-NFL-024-019		PANEL, REAR HRJBNM<(HR)>				
21	83-NFL-027-019		PANEL, REAR KBNM<(K)>				
21	83-NFL-023-019		PANEL, REAR LHBNM<(LH)>				
21	83-NFL-021-019		PANEL, REAR UBNM<(U)>				
22	87-063-164-019		OIL-DMPR 80				

TAPE MECHANISM EXPLODED VIEW 1/1 (EXCEPT U)

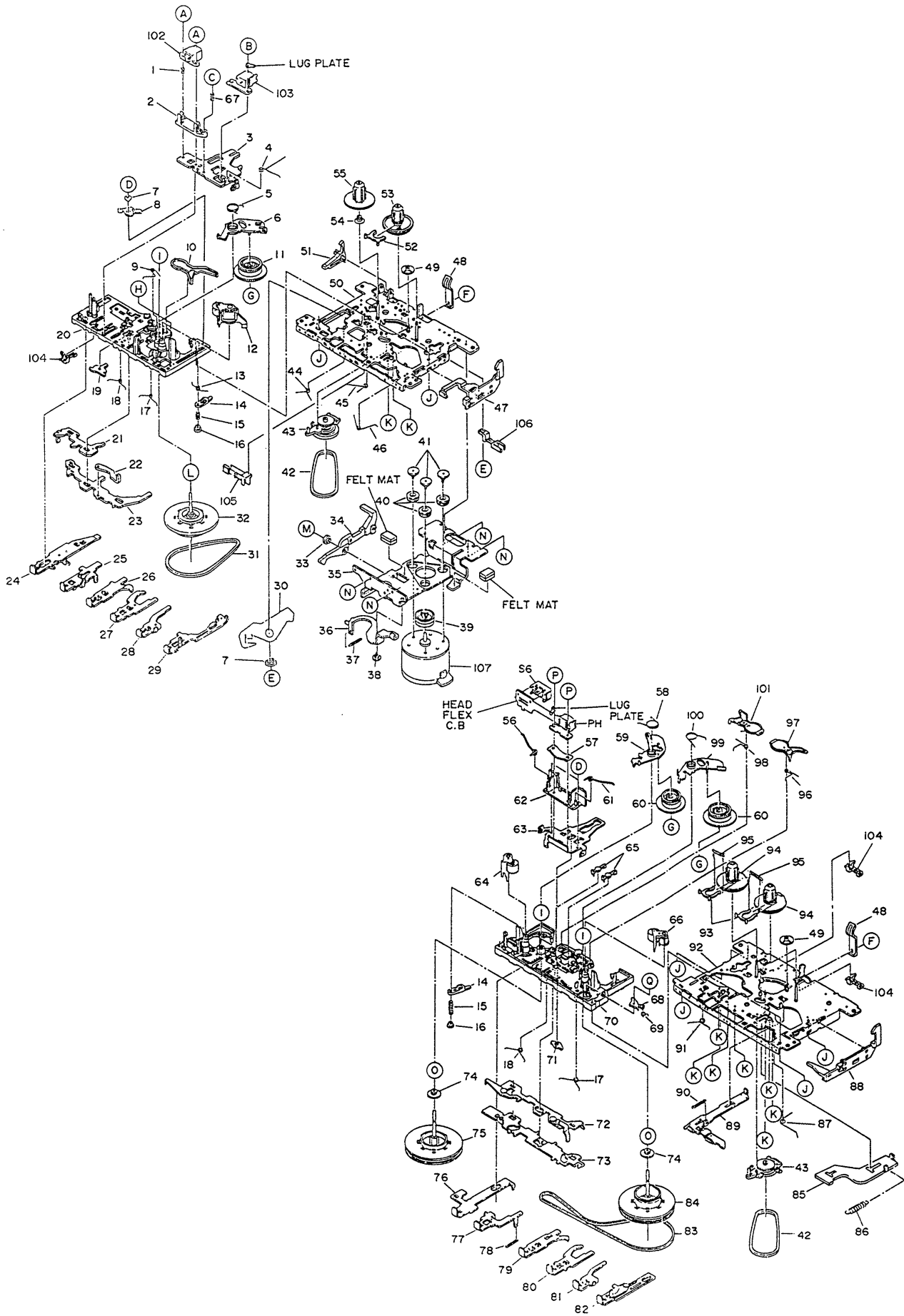

TAPE MECHANISM PARTS LIST 1/1 (EXCEPT U)

DESCRIPTION で判断できない物は“REFERENCE NAME LIST”を参照してください。
If can't understand for Description please kindly refer to “REFERENCE NAME LIST”.

REF. NO	PART NO.	カテゴリ NO.	DESCRIPTION	REF. NO	PART NO.	カテゴリ NO.	DESCRIPTION
1	S1-821-030-080		EH, SPRING	66	S1-959-043-030		RINCH ROLLER ARM(F)ASSY
2	S1-921-030-060		HEAD BASE	67	S1-821-030-070		AZIMUTH SPRING
3	S1-921-030-140		HEAD PANEL	68	S1-959-140-090		ROTARY ARM
4	S1-921-030-090		PANEL P SPR	69	S1-959-140-270		ROTARY SPRING
5	S1-921-260-050		GEAR PLATE SPRING	70	S1-959-143-010		BASE ASSY
6	S1-921-265-020		GEAR PLATE ASSY	71	S1-959-140-230		PR STOPPER
7	S1-921-140-370		P ARM COLLAR	72	S1-959-145-010		ACXTUATOR ASSY
8	S1-921-140-340		P ARM	73	S1-959-140-260		SLIDE PLATE
9	S1-921-141-8A0		M CONTROL SPPRING	74	S1-921-090-100		FL GEAR
10	S1-921-260-4A0		SENSING LEVER	75	S1-959-093-040		FLYWHEEL (R)ASSY
11	S1-921-260-020		CAM GEAR	76	S1-959-140-170		MODE BUTTON LEVER(S)
12	S1-921-043-100		PINCH ROLLER ARM ASSY	77	S1-959-140-160		PLAY BUTTON LEVER(S)
13	S1-921-141-3A0		P CONTROL SPRING	78	S1-959-030-020		SPR, PLATE
14	S1-921-140-820		PAUSE LEVER(F)	79	S1-959-140-150		FF BUTTON LEVER(RS)
15	S1-921-140-120		PAUSE LEVER SPRING	80	S1-959-140-140		FF BUTTON LEVER(FS)
16	S1-921-140-110		PAUSE STOPPER	81	S1-959-140-130		STOP BUTTON LEVER(S)
17	S1-921-140-150		BUTTON LEVER SPRING (B)	82	S1-959-143-030		PROG BUTTON LEVER(S)ASY
18	S1-921-140-140		BUTTON LEVER SPRING (A)	83	S1-851-140-170		MAIN BELT
19	S1-921-140-200		PR STOPPER	84	S1-959-093-050		FLYWHEEL (F)ASSY
20	S1-921-143-180		BASE ASSY	85	S1-959-150-020		MUTING PLATE SP
21	S1-921-140-090		SWITCH ACTUATOR.	86	S1-959-150-010		MUTING PLATE
22	S1-921-140-640		E KICK LEVER	87	S1-959-140-200		SPR, EV ACTUATOR
23	S1-921-140-080		PUSH BUTTON ACTUATOR	88	S1-959-130-020		EJECT SLIDE LEVER(S)
24	S1-921-140-220		REC BUTTON LEVER	89	S1-959-010-020		MAIN PLATE
25	S1-921-140-230		PLAY BUTTON LEVER	90	S1-959-010-030		SPR, MAIN PLATE
26	S1-921-140-240		REW BUTTON LEVER	91	S1-959-140-220		SPR, PM BUTTON LEVER
27	S1-921-140-250		FF BUTTON LEVER	92	S1-959-015-010		CHASSIS ASSY
28	S1-921-140-260		STOP BUTTON LEVER	93	S1-959-050-010		SENSOR
29	S1-921-140-610		PAUSE BUTTON LEVER	94	S1-921-053-090		TAKE UP REEL ASSY
30	S1-921-020-010		REC ARM	95	S1-959-050-040		SPRING
31	S1-821-121-730		MAIN BELT	96	S1-959-260-090		M CONTROL SPR(F)
32	S1-921-093-050		FLYWHEEL ASSY	97	S1-959-260-060		SENSING LEVER(F)
33	S1-821-120-650		COLLAR SCREW(B)	98	S1-959-260-010		M CONTROL SPR(R)
34	S1-921-120-250		P KICK LEVER(B)	99	S1-959-265-010		GEAR PLATE(F)ASSY
35	S1-851-140-070		MOTOR BRACKET	100	S1-959-260-040		GEAR PLATE SPR(F)
36	S1-851-140-060		P KICK LEVER(A)	101	S1-959-260-070		SENSING LEVER(R)
37	S1-851-140-040		SPR P KICK LEVER	102	S6-202-140-190		E HEAD LE15B-C1
38	S1-821-120-230		PK, COLLAR SCREW(A)	103	S6-201-010-750		R. P. HEAD RP-7442BS-0951
39	S1-959-120-010		MOTOR PULLEY	104	S6-401-011-490		LEAF SW MSW-1541T
40	S1-821-120-660		MOTOR RUBBER	105	S6-401-010-380		LEAF SWITCH MSW-1275
41	S1-851-140-180		MOTOR COLLAR SCREW	106	S6-401-011-610		LEAF SW MSW-17820-MVE1
42	S1-821-070-110		RF, BELT	107	S6-002-030-290		MOTOR EG-530YD-28H
43	S1-959-073-010		RF CLUTCH ASSY	A	S9-P17-205-710		SCREW, M2-7. 5
44	S1-921-140-170		P. S. LEVER SPRING	B	S9-B01-200-310		SCREW, +2-3
45	S1-921-140-210		RECBUTTON LEVER SPR	C	S9-F08-200-710		SCREW, M2-7
46	S1-921-140-160		E ACTUATOR SPRING	D	S9-C04-202-530		S-SCREW, TAP 2-2. 5
47	S1-921-130-030		EJECT SLIDE LEVER	E	S9-P04-200-500		SCREW, TAP M2-5
48	S1-829-100-010		SPR, PACK	F	S9-P04-200-310		SCREW, TAP M2-3
49	S1-821-100-700		FF GEAR	G	S9-W06-300-030		HLW CUT 1. 2-3. 8-0. 3
50	S1-921-145-010		CHASSIS ASSY	H	S9-P05-200-610		S-SCREW, TAP 2-6
51	S1-821-100-690		REC SAFETY LEVER	I	S9-W06-500-020		HLW CUT 1. 45-3. 8-0. 5
52	S1-921-050-060		SENSOR	J	S9-B10-200-510		SCREW, TAP 2-5
53	S1-921-053-030		TAKE UP REEL ASSY	K	S9-C07-204-510		SCREW, TAP 2-4. 5
54	S1-821-100-990		SPR, BACK TENSION	L	S9-W01-400-100		PW 2-3. 5-0. 4
55	S1-921-055-040		SUPPLY REEL ASSY	M	S9-P04-200-610		SCREW, TAP M2-6
56	S1-959-040-040		SPR, P. ROLLER ARM(R)	N	S9-P04-200-410		C TAPPING SCREW M2-4
57	S1-851-040-050		PLATE HEAD SPR	O	S9-W05-300-100		HLW 2. 1-3. 5-0. 3
58	S1-959-260-050		GEAR PLATE SPR(R)	P	S9-P14-200-630		S-SCREW, M2-6 BLK
59	S1-959-265-020		GEAR PLATE(R)ASSY	Q	S9-E01-001-520		E RING S1. 5
60	S1-959-260-030		CAM GEAR				
61	S1-959-040-020		SPR, P. ROLLER ARM(F)				
62	S1-959-030-030		HEAD BASE				
63	S1-959-030-010		HEAD PANEL				
64	S1-959-043-040		PINCH ROLLER ARM(R)ASSY				
65	S1-959-260-080		M CONTROL ARM				

TAPE MECHANISM EXPLODED VIEW 1/2 (U)

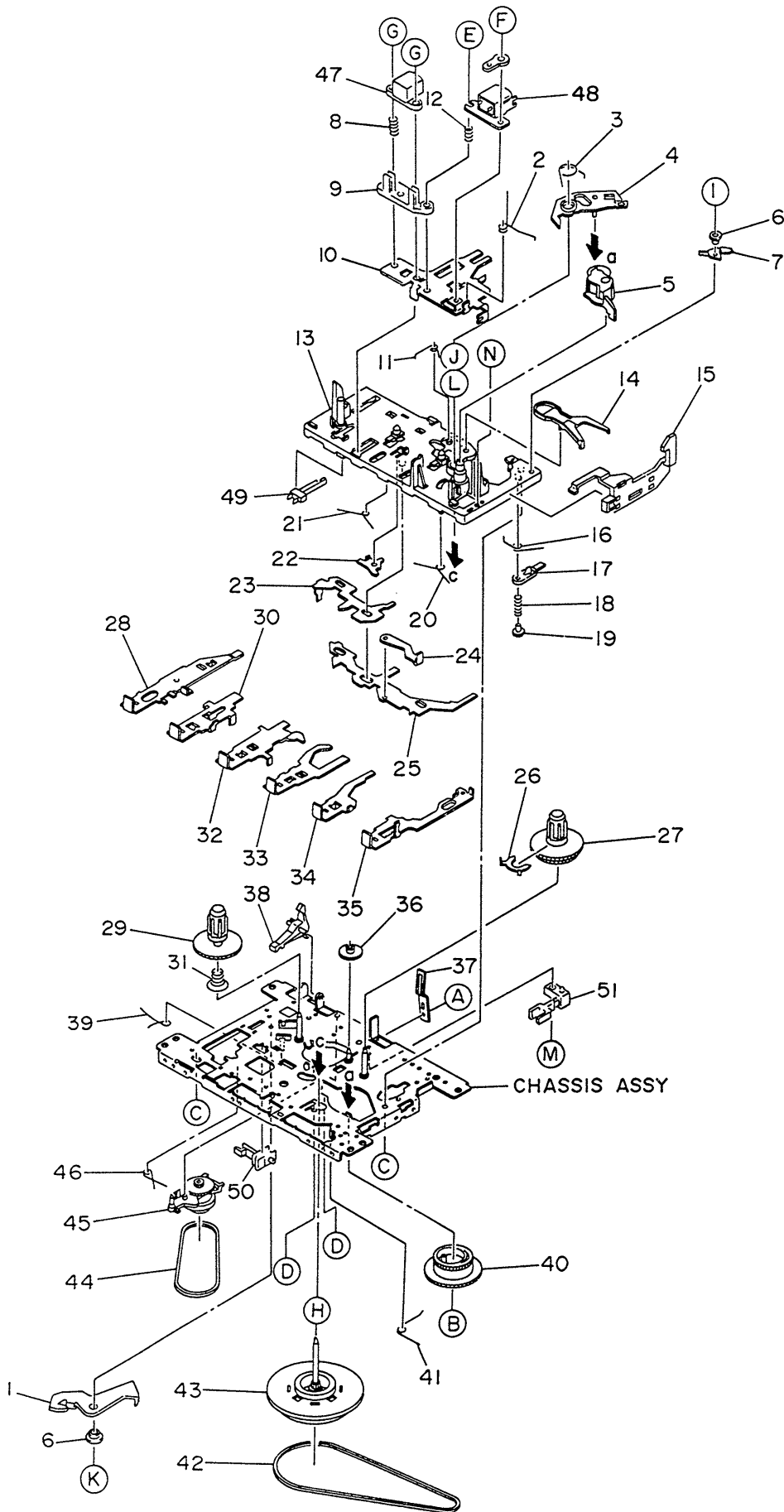

TAPE MECHANISM PARTS LIST 1/2 (U)

DESCRIPTIONで判断できない物は“REFERENCE NAME LIST”を参照してください。
 If can't understand for Description please kindly refer to “REFERENCE NAME LIST”.

REF. NO	PART NO.	カソリ NO.	DESCRIPTION	REF. NO	PART NO.	カソリ NO.	DESCRIPTION
1	S1-921-020-010		REC ARM	36	S1-821-100-700		FF GEAR
2	S1-921-030-090		PANEL P SPRING	37	S1-829-100-010		PACK SPRING
3	S1-921-260-050		GEAR PLATE SPRING	38	S1-821-100-690		RECORD SAFETY LEVER
4	S1-921-265-020		GEAR PLATE ASSY	39	S1-921-140-210		REC BUTTON LEVER SPRING
5	S1-921-043-100		PINCH ROLLER ARM ASSY	40	S1-921-260-020		CAM GEAR
6	S1-921-140-370		P ARM COLLER	41	S1-921-140-160		E ACTUATOR SPRING
7	S1-921-140-340		P ARM	42	S1-921-090-240		MAIN BELT
8	S1-821-030-080		EH SPRING	43	S1-921-093-030		FLYWHEEL ASSY
9	S1-921-030-060		HEAD BASE	44	S1-821-070-110		RF BELT
10	S1-921-030-140		HEAD PANEL	45	S1-921-073-040		RF CLUTCH ASSY
11	S1-921-141-8A0		M CONTROL SPRING	46	S1-921-140-170		P. S. LEVER SPRING
12	S1-821-030-070		AZIMUTH SPRING	47	S6-202-140-190		E HEAD
13	S1-921-143-180		BASE ASSY	48	S6-201-010-750		R. P. HEAD
14	S1-921-260-4A0		SENSING LEVER	49	S6-401-011-490		LEAF SW MSW-1541T
15	S1-921-130-020		EJECT SLIDE LEVER	50	S6-401-011-610		LEAF SW MSW-17820MVE1
16	S1-921-141-3A0		P CONTROL SPRING	51	S6-401-010-380		LEAF SW MSW-1275
17	S1-921-140-550		PAUSE LEVER(E)	A	S9-179-000-000		C TAP SCREW M2-3
18	S1-921-140-120		PAUSE LEVER SPRING	B	S9-422-000-000		P WASHER CUT 12-3. 8-0. 3
19	S1-921-140-110		PAUSE STOPPER	C	S9-679-000-000		P TAP SCREW M2-5
20	S1-921-140-150		BUTTON LEVER SPRING(B)	D	S9-999-180-090		TAP SCREW M2-4. 5
21	S1-921-140-140		BUTTON LEVER SPRING(A)	E	S9-922-000-000		AZIMUTH SCREW M2-8
22	S1-921-140-200		PR STOPPER	F	S9-115-000-000		+ BIND SCREW M2-3
23	S1-921-140-090		SWITCH ACTUATOR	G	S9-821-000-000		+CAP SCREW M2-8
24	S1-921-140-640		E KICK LEVER	H	S9-882-000-000		P WASHER 2-3. 5-0. 4
25	S1-921-140-080		PUSH BUTTON ACTUATOR	I	S9-999-200-410		P TAP SCREW M2-3
26	S1-921-050-060		SENER	J	S9-999-030-130		P WASHER CUT 1. 45-3. 8-0.
27	S1-921-053-030		TAKE UP REEL ASSY	K	S9-180-000-000		C TAP SCREW M2-4
28	S1-921-140-220		REC BUTTON LEVER	L	S9-999-000-030		P WASHER2. 1-4-0. 13
29	S1-921-053-040		SUPPLY REEL ASSY	M	S9-181-000-000		C TAP SCREW M2-5
30	S1-921-140-230		PLAY BUTTON LEVER	N	S9-P05-200-610		S TAPPING SCREWM2-6
31	S1-821-100-990		BACK TENSION SPRING				
32	S1-921-140-240		REW BUTTON LEVER				
33	S1-921-140-250		FF BUTTON LEVER				
34	S1-921-140-660		STOP BUTTON LEVER				
35	S1-921-140-610		PAUSE BUTTON LEVER				

TAPE MECHANISM EXPLODED VIEW 2/2 (U)

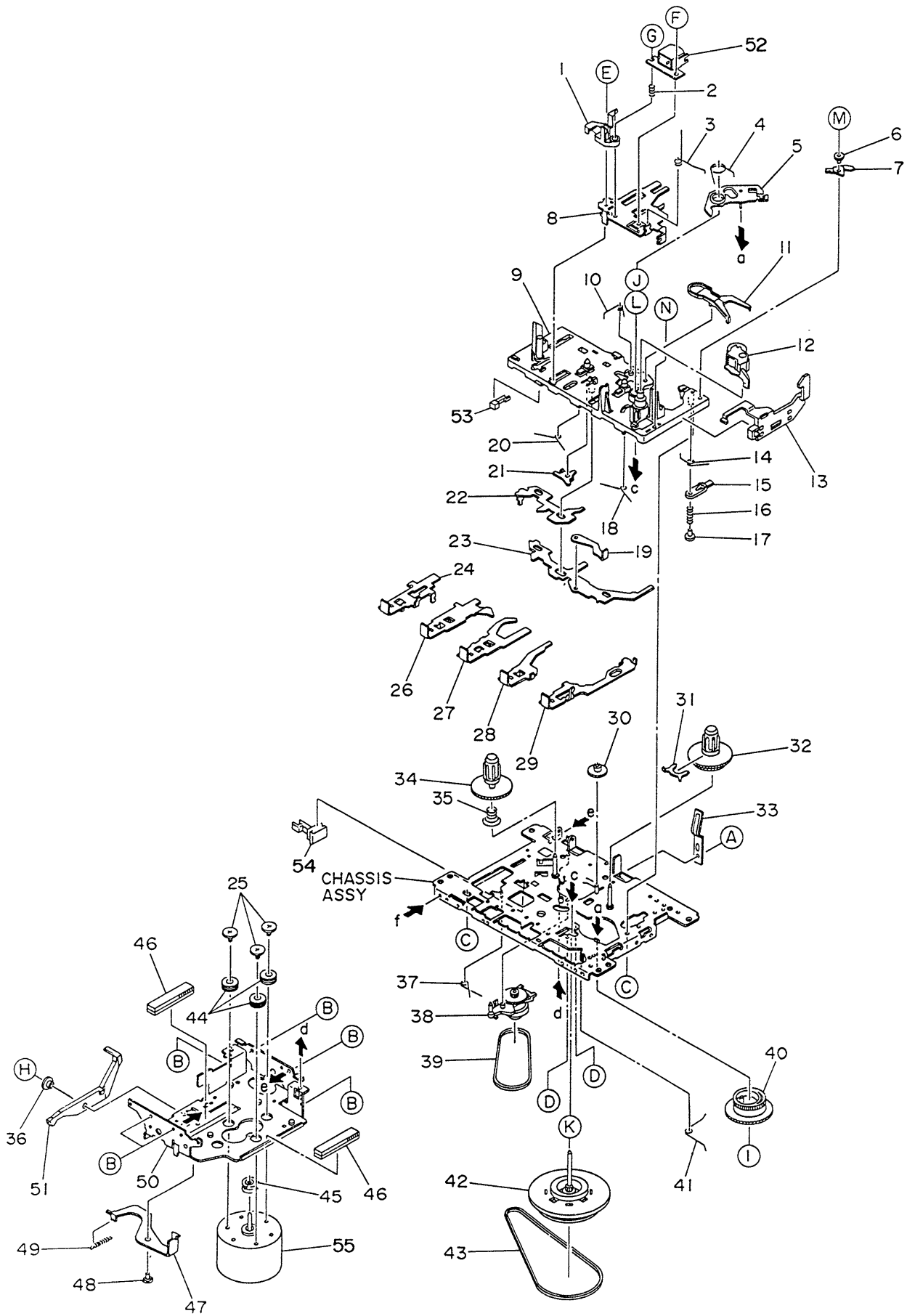

TAPE MECHANISM PARTS LIST 2/2 (U)

REF. NO	PART NO.	カフリ NO.	DESCRIPTION	REF. NO	PART NO.	カフリ NO.	DESCRIPTION
1	S1-921-030-4A0		HEAD BASE	36	S1-821-120-650		COLLER B
2	S1-821-030-070		AZIMUTH SPRING	37	S1-921-140-170		P. S. LEVER SPRING
3	S1-921-030-090		PANEL P SPRING	38	S1-921-073-040		RF CLUTCH ASSY
4	S1-921-260-050		GEAR PLATE SPRING	39	S1-821-070-110		RF BELT
5	S1-921-265-020		GEAR PLATE ASSY	40	S1-921-260-020		CAM GEAR
6	S1-921-140-370		P ARM COLLER	41	S1-921-140-160		E ACTUATOR SPRING
7	S1-921-140-340		P ARM	42	S1-921-093-040		FLYWHEEL ASSY
8	S1-921-030-110		HEAD PANEL	43	S1-921-090-240		MAIN BELT
9	S1-921-143-170		BASE ASSY	44	S1-820-130-060		MOTOR RUBBER
10	S1-921-141-8A0		M CONTROL SPRING	45	S1-921-120-130		MOTOR PULLEY
11	S1-921-260-4A0		SENSING LEVER	46	S1-921-120-120		ANTI VIBR FELT MAT
12	S1-921-043-100		PINCH ROLLER ARM ASSY	47	S1-821-120-680		P KICK LEVER (A)
13	S1-921-130-020		EJECT SLIDE LEVER	48	S1-821-120-230		PK COLLER SCREW A
14	S1-921-141-3A0		P CONTROL SPRING	49	S1-821-120-250		P KICK LEVER SPRING
15	S1-921-140-550		PAUSE LEVER(E)	50	S1-921-120-110		MOTOR BRACKET
16	S1-921-140-120		PAUSE LEVER SPRING	51	S1-921-120-090		P KICK LEVER
17	S1-921-140-110		PAUSE STOPPER	52	S6-201-010-750		R. P. HEAD
18	S1-921-140-150		BUTTON LEVER SPRING(B)	53	S6-401-011-490		LEAF SW MSW-1541T
19	S1-821-011-590		E KICK LEVER	54	S6-401-011-610		LEAF SW MSW-17820MVE1
20	S1-921-140-140		BUTTON LEVER SPRING(A)	55	S6-002-030-290		MOTOR EG530YD-2BH
21	S1-921-140-200		PR STOPPER	A	S9-179-000-000		C TAP SCREW M2-3
22	S1-921-140-090		SWITCH ACTUATOR	B	S9-180-000-000		C TAP SCREW M2-4
23	S1-921-140-080		PUSH BUTTON ACTUATOR	C	S9-679-000-000		P TAP SCREW M2-5
24	S1-921-140-230		PLAY BUTTON LEVER	D	S9-999-180-090		TAP SCREW M2-4. 5
25	S1-821-120-020		MOTOR COLLER SCREW	E	S9-004-000-000		SCREW M2-6
26	S1-921-140-240		REW BUTTON LEVER	F	S9-115-000-000		+ BIND SCREW M2-3
27	S1-921-140-250		FF BUTTON LEVER	G	S9-922-000-000		AZIMUTH SCREW M2-8
28	S1-921-140-260		STOP BUTTON LEVER	H	S9-182-000-000		C TAP SCREW M2-6
29	S1-921-140-610		PAUSE BUTTON LEVER	I	S9-422-000-000		P WASHER CUT 12-3. 8-0. 3
30	S1-821-100-700		FF GEAR	J	S9-999-030-130		P WASHER CUT 1. 45-3. 8-0.
31	S1-921-050-060		SENSOR	K	S9-882-000-000		P WASHER 2-3. 5-0. 4
32	S1-921-053-030		TAKE UP REEL ASSY	L	S9-999-000-030		P WASHER2. 1-4-0. 13
33	S1-829-100-010		PACK SPRING	M	S9-999-200-410		P TAP SCREW M2-3
34	S1-921-053-040		SUPPLY REEL ASSY	N	S9-P05-200-610		S TAPPING SCREW M2-6
35	S1-821-100-990		BACK TENSION SPRING				

REFERENCE NAME LIST

ELECTRICAL SECTION

DESCRIPTION	REFERENCE NAME
ANT	ANTENNAS
C-	CHIP
C-CAP	CAP, CHIP
C-CAP TN	CAP, CHIP TANTALUM
C-COIL	COIL, CHIP
C-DI	DIODE, CHIP
C-DIODE	DIODE, CHIP
C-FET	FET, CHIP
C-FOTR	FILTER, CHIP
C-JACK	JACK, CHIP
C-LED	LED, CHIP
C-RES	RES, CHIP
C-SFR	SFR, CHIP
C-SLIDE SW	SLIDE SWITCH, CHIP
C-SW	SWITCH, CHIP
C-TR	TRANSISTOR, CHIP
C-VR	VOLUME, CHIP
C-ZENER	ZENER, CHIP
CAP, CER	CAP, CERA-SOL
CAP, E	CAP, ELECT
CAP, M/F	CAP, FILM
CAP, TC	CAP, CERA-SOL
CAP, TC-U	CAP, CERA-SOL SS
CAP, TN	CAP, TANTALUM
CERA FIL	FILTER, CERAMIC
CF	FILTER, CERAMIC
DL	DELAY LINE
E/CAP	CAP, ELECT
FILT	FILTER
FLTR	FILTER
FUSE RES	RES, FUSE
MOT	MOTOR
P-DIODE	PHOTO DIODE
P-SNSR	PHOTO SENSER
P-TR	PHOTO TRANSISTOR
POLY VARI	VARIABLE CAPACITOR
PPCAP	CAP, PP
PT	POWER TRANSFORMER
PTR, RES	PTR, MELF
RC	REMOTE CONTROLLER
RES NF	RES, NON-FLAMMABLE
RESO	RESONATOR
SHLD	SHIELD
SOL	SOLENOID
SPKR	SPEAKER
SW, LVR	SWITCH, LEVER
SW, RTRY	SWITCH, ROTARY
SW, SL	SWITCH, SLIDE
TC CAP	CAP, CERA-SOL
THMS	THERMISTOR
TR	TRANSISTOR
TRIMMER	CAP, TRIMMER
TUN-CAP	VARIABLE CAPACITOR
VIB, CER	RESONATOR, CERAMIC
VIB, XTAL	RESONATOR, CRYSTAL
VR	VOLUME
ZENER	DIODE, ZENER
サージサプレッサ	SERGESUPPRESSOR
セラコン	CAP,CERA

MECHANICAL SECTION

DESCRIPTION	REFERENCE NAME
ADHESHIVE	SHEET ADHESHIVE
AZ	AZIMUTH
BAR-ANT	BAR-ANTENNA
BAT	BATTERY
BATT	BATTERY
BRG	BEARING
BTN	BUTTON
CAB	CABINET
CASS	CASSETTE
CHAS	CHASSIS
CLR	COLLAR
CONT	CONTROL
CRSR	CURSOR
CU	CUSHION
CUSH	CUSHION
DIR	DIRECTION
DUBB	DUBBING
FL	FRONT LOADING
FLY-WHL	FLYWHEEL
FR	FRONT
FUN	FUNCTION
G-CU	G-CUSHION
HDL	HANDOL
HIMERON	CLOTH
HINGE, BAT	HINGE, BATTERY
HLDR	HOLDER
HT-SINK	HEAT SINK
IB	INSTRUCTION BOOKLET
IDLE	IDLER
IND, L-R	INDICATOR, L-R
KEY, CONT	KEY, CONTROL
KEY, PRGM	KEY, PROGRAM
KNOB, SL	KNOB, SLIDE
LBL	LABEL
LID, BATT	LID, BATTERY
LID, CASS	LID, CASSETTE
LVR	LEVER
P-SP	P-SPRING
PANEL, CONT	PANEL, CONTROL
PANEL, FR	PANEL, FRONT
PRGM	PROGRAM
PULLY, LOAD MO	PULLY, LOAD MOTOR
RBN	RIBBON
S-	SPECIAL
SEG	SEGMENT
SH	SHEET
SHLD-SH	SHIELD-SHEET
SL	SLIDE
SP	SPRING
SP-SCREW	SPECIAL-SCREW
SPACER, BAT	SPACER, BATTERY
SPR	SPRING
SPR-P	P-SPRING
SPR-PC-PUSH	P-SPRING, C-PUSH
T-SP	T-SPRING
TERM	TERMINAL
TRIG	TRIGGER
TUN	TUNING
VOL	VOLUME
W	WASHER
WHL	WHEEL
WORM-WHL	WORM-WHEEL
ジグアーム	ARM,SHAFT
ジグガイド	GUIDE,SHAFT
ストラップ	STRAP
トクナベ	S-SCREW
ヒンジ	HINGE
ヒンジビス	S-SCREW
ビスセレート	SCREW,SERRART

サービス技術ニュース	
番号	連絡内容
G - -	
G - -	
G - -	

アイワ株式会社
AIWA CO.,LTD.

921502 750038

Tokyo Japan