

4-BAND RADIO CASSETTE RECORDER

MODEL NO. TPR-968E,K

AIWA®

[SERVICE MANUAL]

Code No. 03-968-000-18

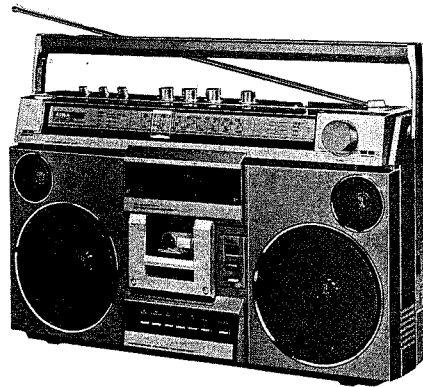

DATE OF ISSUE 9/1980

SPECIFICATIONS

GENERAL

Semiconductors:	4 ICs, 1 FET, 27 transistors, 17 diodes, 7 LED's
Power source:	Batteries DC 12V (UM-1 x 8) E model AC 120V/220V switchable 50/60 Hz K model AC 120V/240V switchable 50/60 Hz Car battery (thru car adaptor)
Power consumption:	17W
Speakers:	160mm ϕ x 2 50mm ϕ x 2
Dimension:	557(W) x 331(H) x 177(D) mm
Weight:	7.2 kg
Supplied accessories:	AC power cord x 1 Cassette tape x 1

RADIO SECTION

Circuit:	Superheterodyne
Frequency range:	FM 87.4 ~ 108.3 MHz SW 5.8 ~ 18.5 MHz MW 515 ~ 1650 kHz LW 145 ~ 320 kHz
Intermediate frequency:	FM 10.7 MHz SW, MW, LW 468 kHz
Sensitivity:	
(IHF, THD 3%)	FM 7 \pm 3 dB (at 88 MHz) 10 \pm 3 dB (at 98 MHz) 13 \pm 3 dB (at 108 MHz)
(S/N 10 dB)	SW 35 \pm 4 dB (at 5.9 MHz) 18 \pm 4 dB (at 12.0 MHz) 12 \pm 4 dB (at 18.0 MHz)
(S/N 10 dB)	MW 38 \pm 4 dB (at 600, 1000, 1440 kHz)
(S/N 10 dB)	LW 47 \pm 4 dB (at 150 kHz) 44 \pm 4 dB (at 200 kHz) 42 \pm 4 dB (at 300 kHz)

Image rejection:	FM 37 \pm 4 dB (at 108 MHz) SW 12 \pm 6 dB (at 18 MHz) MW 42 \pm 4 dB (at 1400 kHz) LW 46 \pm 4 dB (at 300 kHz)
IF rejection:	FM 80 \pm 6 dB (at 88 MHz) MW 42 \pm 4 dB (at 1400 kHz) LW 46 \pm 4 dB (at 300 kHz)

TAPE RECORDER SECTION

Tape speed:	4.8 cm/s. \pm 2.5%
Recording system:	AC bias
Erasing system:	AC erase
Record bias frequency:	61 \pm 0.5 kHz
Distortion:	Less than 1.5% (PB) Less than 1.5% (REC/PB)
Frequency response:	METAL tape 50 ~ 14,000 Hz CrO ₂ tape 50 ~ 13,000 Hz LH tape 50 ~ 12,000 Hz
Signal to noise ratio:	More than 54/50 dB (Un-weighted) [DC/AC] (PB) More than 47/44 dB [DC/AC] (REC/PB)
Erasing ratio:	More than 60 dB
Separation:	More than 39 dB (REC/PB)
Maximum output power:	4.2W + 4.2W
FF & rewind time:	80 \pm 5 s. (at C-60)
Automatic stop system:	Mechanical auto stop
Pinch roller pressure:	350 \pm 25g (3.43 \pm 0.25N)
Wow and flutter:	Less than 0.07% (WRMS)
Take-up torque:	50 \pm 10g-cm (0.49 \pm 0.098 mN·m)
FF & rewind torque:	100 \pm 20 g-cm (0.98 \pm 0.196 mN·m) -10 g-cm (-0.098 mN·m)

- Specifications and external appearance are subject to change without notice due to product improvement.

DISASSEMBLY INSTRUCTIONS

1. To Remove Back Cover

- 1) Remove the 8 screws. (See figure 1)

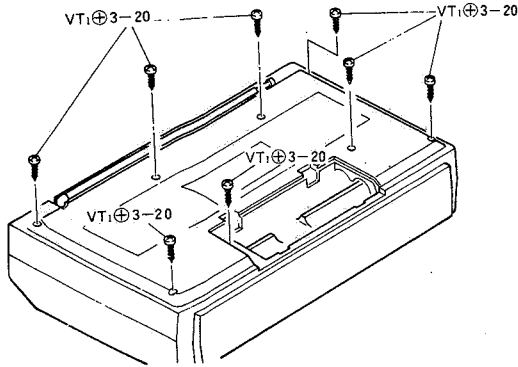

Fig. 1

- 2) Detach 3 connectors.

Caution: Take extra care when disconnecting the antenna terminal. (See figure 2)

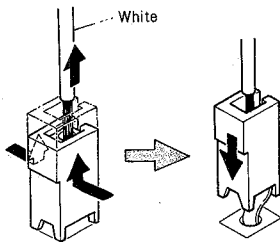

Fig. 2

2. To Remove Tuner Circuit Board

- 1) Remove the 5 screws. (See figure 3)

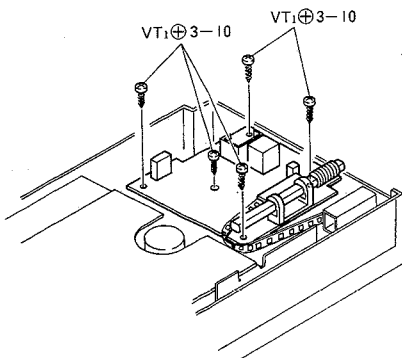

Fig. 3

3. To Remove REC/PB Circuit Board

- 1) Remove the 5 screws. (See figure 4)

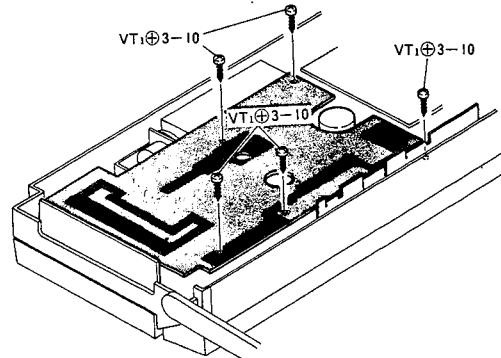

Fig. 4

4. To Remove Radio Chassis

- 1) Remove the two screws and take off the cassette cover. (See figure 5)

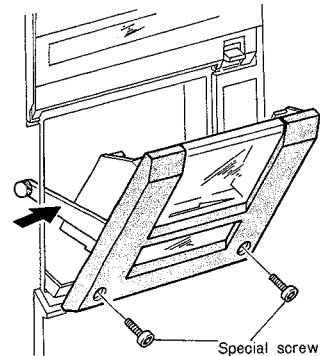

Fig. 5

- 2) Remove all control knobs (total 9 pieces). (See figure 6)

- 3) Remove the connector.

- 4) Remove the 7 screws. (See figure 6)

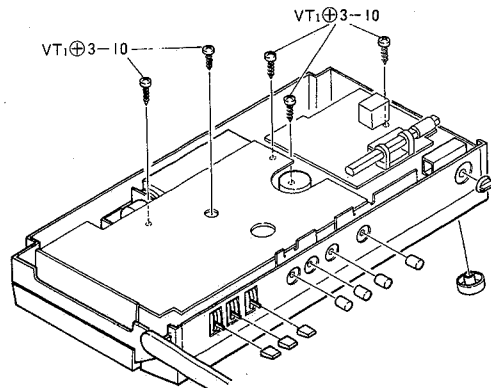

Fig. 6

5. To Remove Mechanism Block

- 1) Slip off the counter belt.
- NOTE: Because the system of attaching the counter belt on this model is different from previous types, please note position prior to removal.
- 2) Remove the air damp spring. (See figure 7)

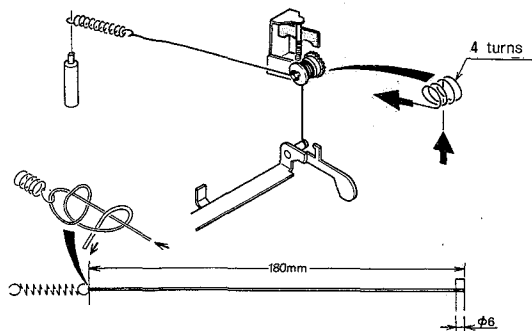

Fig. 7

- 3) Remove the 8 screws. (See figure 8)
- 4) When reinserting the mechanism block, replace the 7 screws in their numerical order as shown in figure 8. (See figure 8)

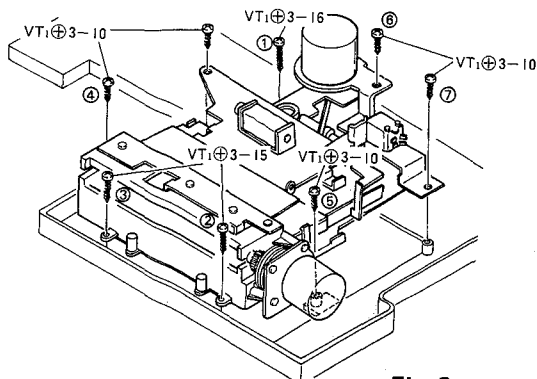

Fig. 8

6. To Remove the Motor Drive Mechanism (MD-1)

- 1) Remove the 2 screws.
- 2) Remove the E-spring (record prevention mechanism). (See figure 9)

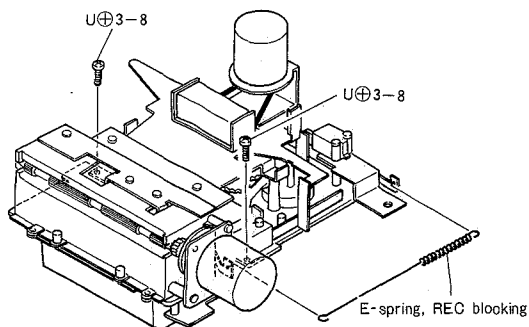

Fig. 9

Adjustment of motor drive mechanism (MD-1), precautions to be taken in parts replacement.

This mechanism has been connected to the PM-1 mechanism, but since it performs complex functions, it is necessary to confirm adjustment procedures. Refer to the information below when making repairs or replacing parts.

1. Motor replacement

- 1) Remove the 3 screws. (See figure 10)

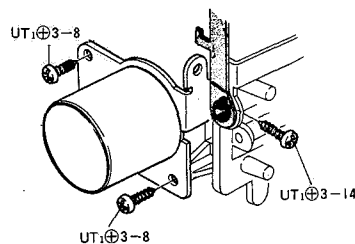

Fig. 10

2. Replacement of lever (gear stopper)

- 1) Stretch out the mechanism frame a to the left and right, remove the axis (gear stopper), and replace it. (See figure 11)

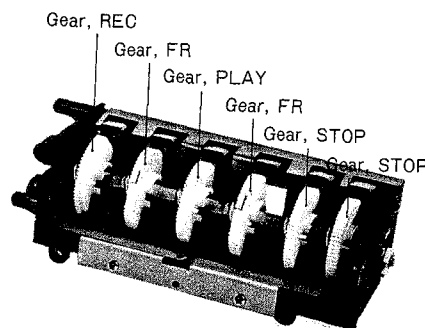

Fig. 11

3. Replacement of gears (REC, FR, PLAY, STOP)

- 1) Remove the 3 screws from the motor holder. (See figure 10)
- 2) Remove the 2 screws and take off the mechanism frame B ass'y. (See figure 12)

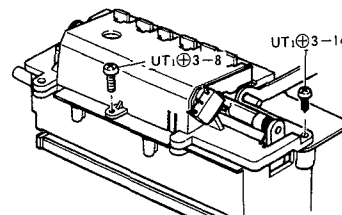

Fig. 12

- 3) Take off the E-ring, and remove the axis (gear play). At this time be sure to keep the gears in their proper order. (See figure 13)

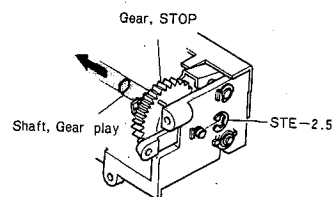

Fig. 13

- 4) After gear replacement, return each gear to its proper position. (See figure 14)

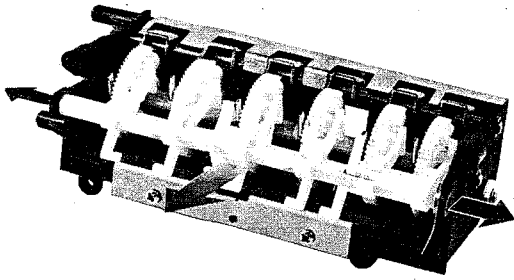

Fig. 14

- 4) Confirm that the assembly will not move even if the lever (gear stopper) is pressed. (See figure 17)

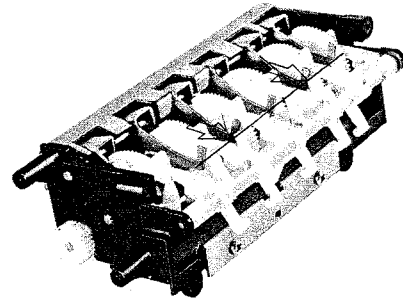

Fig. 17

4. When assembling the MD-1 mechanism

When reinserting the MD-1 mechanism, please give extra attention to the following critical points.

MECHANISM MUST BE INSERTED PROPERLY OR MALFUNCTION WILL RESULT.

- 1) After assembling each gear (REC, FR, PLAY, STOP) make sure that the hub of the lever assembly (pushbutton) is inserted into the inside of the cam on each respective gear.
- 2) Rotate each gear to the right and align the levers (pushbutton) to the same position. (See figure 15)

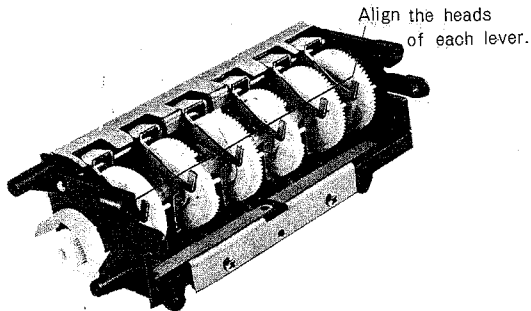

Fig. 15

- 5) Insert the mechanism frame from above as shown in the illustration, and temporarily secure it. (See figure 18)

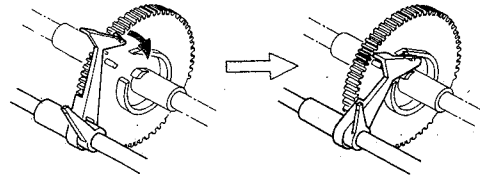

Fig. 18

- 6) Check to see if the P-spring (lever stopper) is properly set on the lever (gear stopper). (See figure 19)

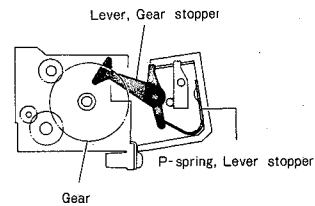

Fig. 19

- 3) Insert the hub of the lever (gear stopper) into the cam of each gear. (See figure 16)

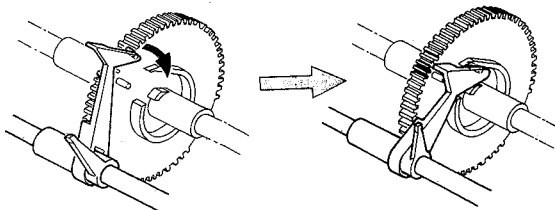

Fig. 16

- 7) Check to see if the lever (gear stopper) is properly inserted into the plate. (See figure 20)

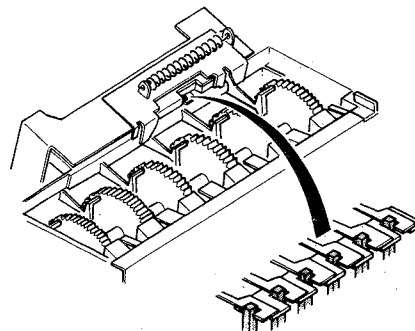

Fig. 20

- 8) After carrying out steps 1-7 in their proper order, check to see if the MD-1 mechanism will operate normally.
- 9) Replace the mechanism according to the steps described in the previous part "3".

5. Adjustment of micro switch timing

- 1) Rotate the micro switch to the right and when the switch is in the ON position, rotate the microswitch back to the left. Temporarily fix it at the position where it goes off. (See figure 21)

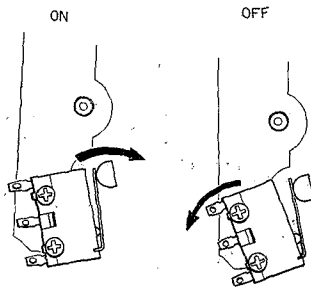

Fig. 21

- 2) By gently pressing the STOP control the microswitch will come on. Check to see if the motor is rotating at this point. Next, by releasing your finger from the STOP control the button will return, and when the microswitch goes OFF, check to see if there is a gap of approximately 0.3mm between the lever switch and the microswitch. (See figure 22)

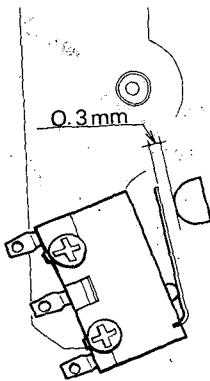

Fig. 22

- 3) Press the FF control. When the microswitch comes on, the motor will commence rotation. When you remove your finger the button will return to its original position. At this point check to make sure the microswitch is OFF.
- 4) After checking the above 2) and 3), secure the microswitch in its present position.

NOTE: When checking steps 2) and 3), make sure that the microswitch operation commences BEFORE gear operation. If the following problems occur, adjustment procedure should be repeated.

- 1) Microswitch and gears (FF, STOP) function at the same time.
- 2) Gears (FF, STOP) function before microswitch.

6. Docking of MD-1 and PM-1 mechanisms

- 1) After docking the above, temporarily fix their positions
- 2) After pressing the slide plate (FR) in the direction of the arrow, secure the mechanism assembly screws. (See figure 23)

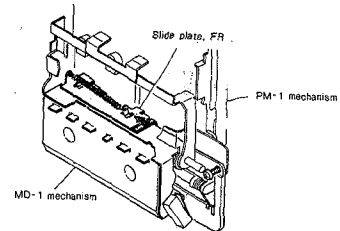

Fig. 23

7. Reattachment of E-spring (record prevention)

- 1) After docking of MD-1 and PM-1 mechanism is complete, refer to figure 26 to make sure the E-spring (record prevention mechanism) is reattached properly. (See figure 24)

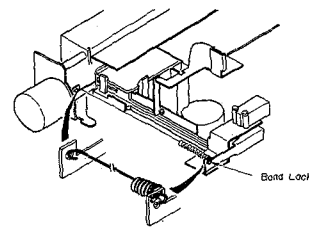
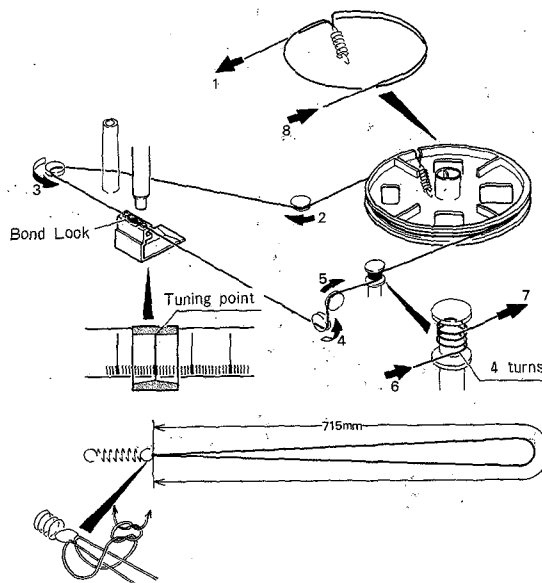
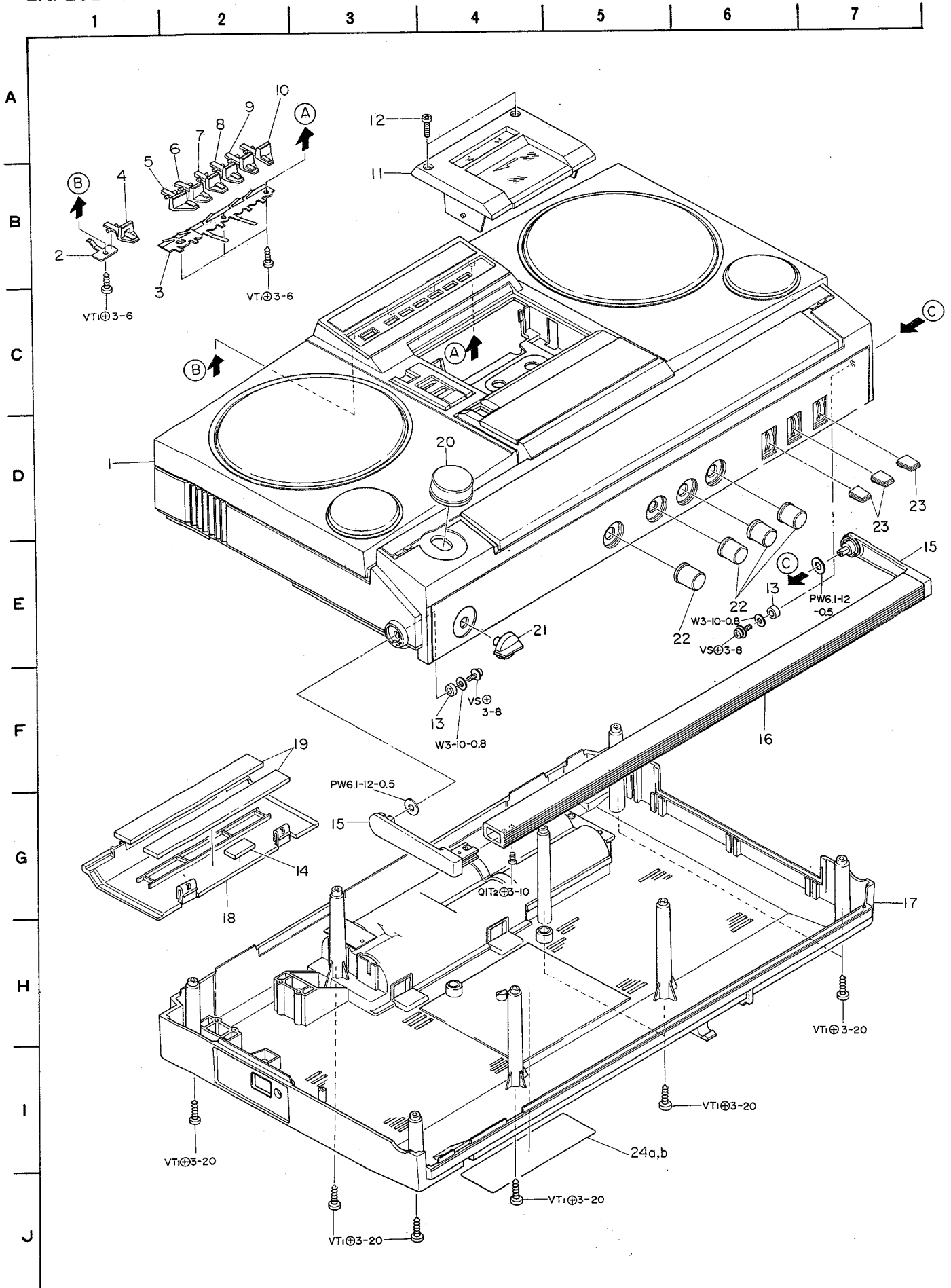

Fig. 24

DIAL CORD STRINGING



EXPLODED VIEW-1



PARTS LIST

MECHANICAL PARTS

■ * mark in this part list shows exclusive part (which is used) for only Model No. TPR-968

Ref. No.	Part No.	Part No. Changed to	Description	Common Model	Q'ty	
1-1	09-017-797-01		Main cabinet ass'y	*	1	
	82-571-049-01		Main cabinet	*	1	
	82-571-003-01		Window, Dial	*	1	
	82-563-032-01		Cassette plate	TPR-990	1	
	82-571-004-01		Name, Window	*	1	
	82-571-005-01		Panching, Woofer	*	2	
	82-571-006-01		Panching, Tweeter R	*	1	
	82-571-007-01		Speaker ring, Woofer	*	2	
	82-571-008-01		Speaker ring, Tweeter	*	2	
	82-571-035-01		Window, Control	*	1	
	82-571-033-01		Window, Meter	*	1	
	82-571-025-01		Decorative screw	*	2	
	82-571-026-01		Panching, Tweeter L	*	1	
	82-571-050-01		Panel, Top	*	1	
	82-571-027-01		Name, Control	*	1	
	82-571-029-01		Panel, Meter	*	1	
	82-321-074-01		QT ₁ + 2.6-8		4	
	87-321-095-01		QT ₁ + 3-8		2	
	1-2	82-571-242-01		Metal fitting 19.5-10.1	*	1
	1-3	82-563-253-01		Plate, Push-key ass'y	TPR-990	1
1-4	82-571-010-01		Push-key	*	1	
1-5	82-571-024-01		Push-key, PAUSE	*	1	
1-6	82-571-023-01		Push-key, STOP	*	1	
1-7	82-571-022-01		Push-key, FF	*	1	
1-8	82-571-021-01		Push-key, FWD	*	1	
1-9	82-571-020-01		Push-key, REW	*	1	
1-10	82-571-019-01		Push-key, REC	*	1	
1-11	09-017-799-01		Cassette lid ass'y	*	1	
	82-571-046-01		Cassette lid ass'y	*	1	
	82-461-319-01		Cushion, Cassette lid	TPR-930	1	
	82-541-264-01		P-spring, Cassette holder R	TPR-950	1	
	82-541-265-01		P-spring, Cassette holder L	TPR-950	1	
1-12	82-562-047-01		Decorative screw	TPR-926A	2	
1-13	82-571-234-01		Felt, Carrying handle	*	2	
1-14	93-464-154-01		Cushion, Battery	*	1	
1-15	82-571-036-01		Handle	*	2	
1-16	82-571-037-01		Handle grip	*	1	
1-17	09-017-798-01		Back cover ass'y	*	1	
	82-571-002-01		Back cover	*	1	
	82-563-213-01		Holder, Battery	TPR-990	1	
	82-571-032-01		Jack plate, POWER	*	1	
	82-571-056-01		Jack name	*	1	
	82-222-036-01		Spring, Battery		2	
	82-551-213-01		Plate, Battery	TPR-935	1	
	82-551-248-01		Faiber, 24-31	TPR-935	1	
	87-038-032-01		Terminal plate, Battery		2	
	87-351-096-01		UT ₁ + 3-10		2	
	1-18	82-571-018-01		Battery room lid	*	1
	1-19	82-563-280-01		Cushion, Battery room lid	TPR-990	2
	1-20	82-571-041-01		Knob, Tuning	*	1
	1-21	82-562-051-01		Knob, band	TPR-926	1
	1-22	82-571-042-01		Knob, Volume	*	4
1-23	82-570-009-01		Lever knob		3	
1-24a	82-571-051-01		Name plate, Spec (E model only)	*	1	
1-24b	82-571-052-01		Name plate, Spec (K model only)	*	1	

EXPLODED VIEW-2

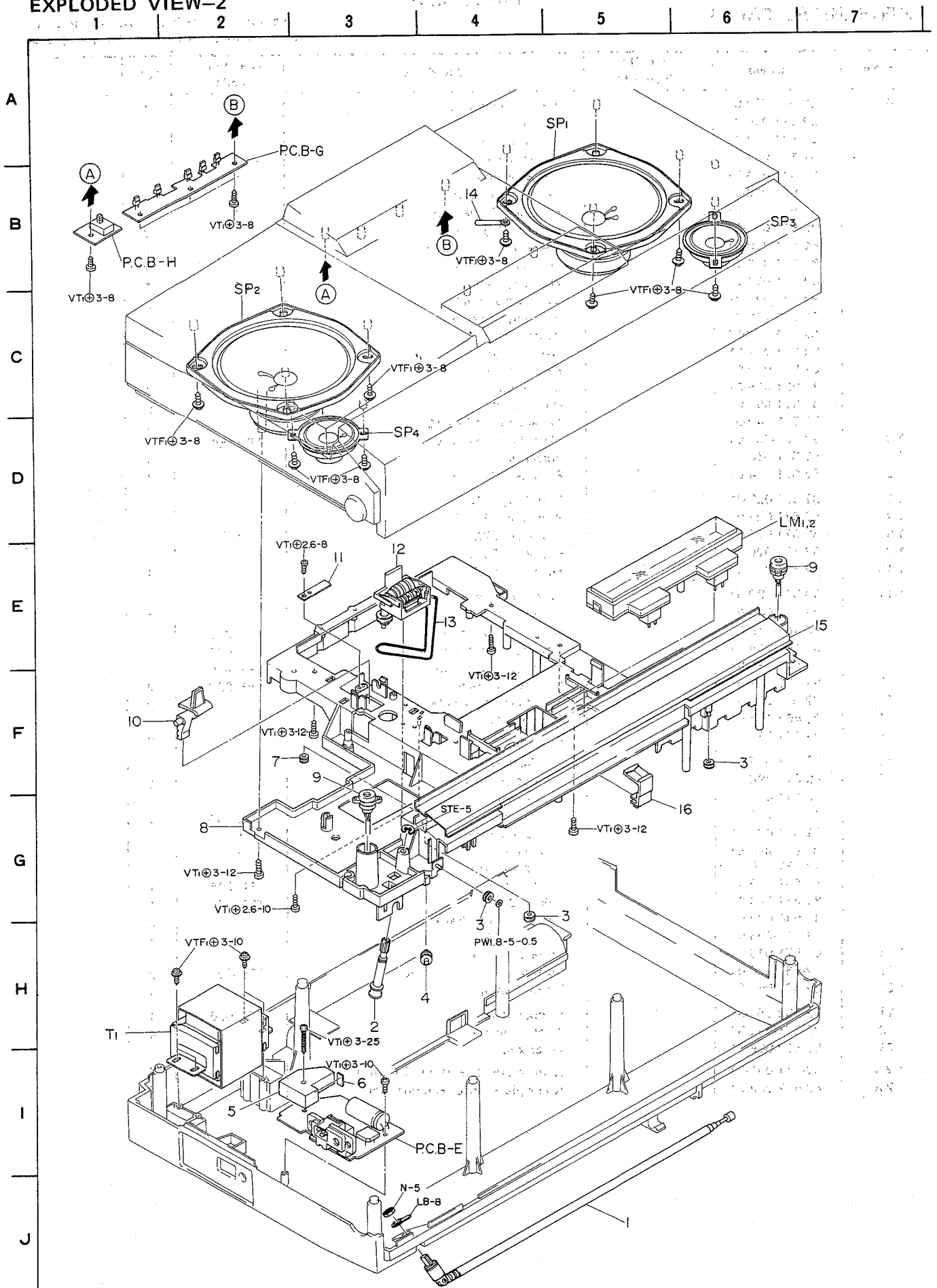

Ref. No.	Part No.	Part No. Changed to	Description	Common Model	Q'ty
2-1	87-043-049-01		Rod antenna		1
2-2	82-571-215-01		Shaft, Tuning	*	1
2-3	81-302-107-01		Roller		3
2-4	82-439-317-01		Roller	TPR-300	1
2-5	82-551-246-01		Cover, Fuse	TPR-935	1
2-6	82-563-293-01		Plate	TPR-910	1
2-7	81-385-014-01		Roller		2
2-8	82-571-201-01		Chassis, Main	*	1
2-9	87-064-097-01		ECM holder 30M		2
2-10	82-563-019-01		Knob, Eject	TPR-990	1
2-11	82-551-263-01		P-spring, Cassette-up	TPR-935	1
2-12	87-040-133-01		Counter		1
2-13	82-385-314-01		Rubber belt, Worm	AD-6300	1
2-14	87-038-039-01		Wire binder		1
2-15	82-571-054-01		Dial plate	*	1
2-16	82-571-013-01		Pointer, Tuning dial	*	1

EXPLODED VIEW-3

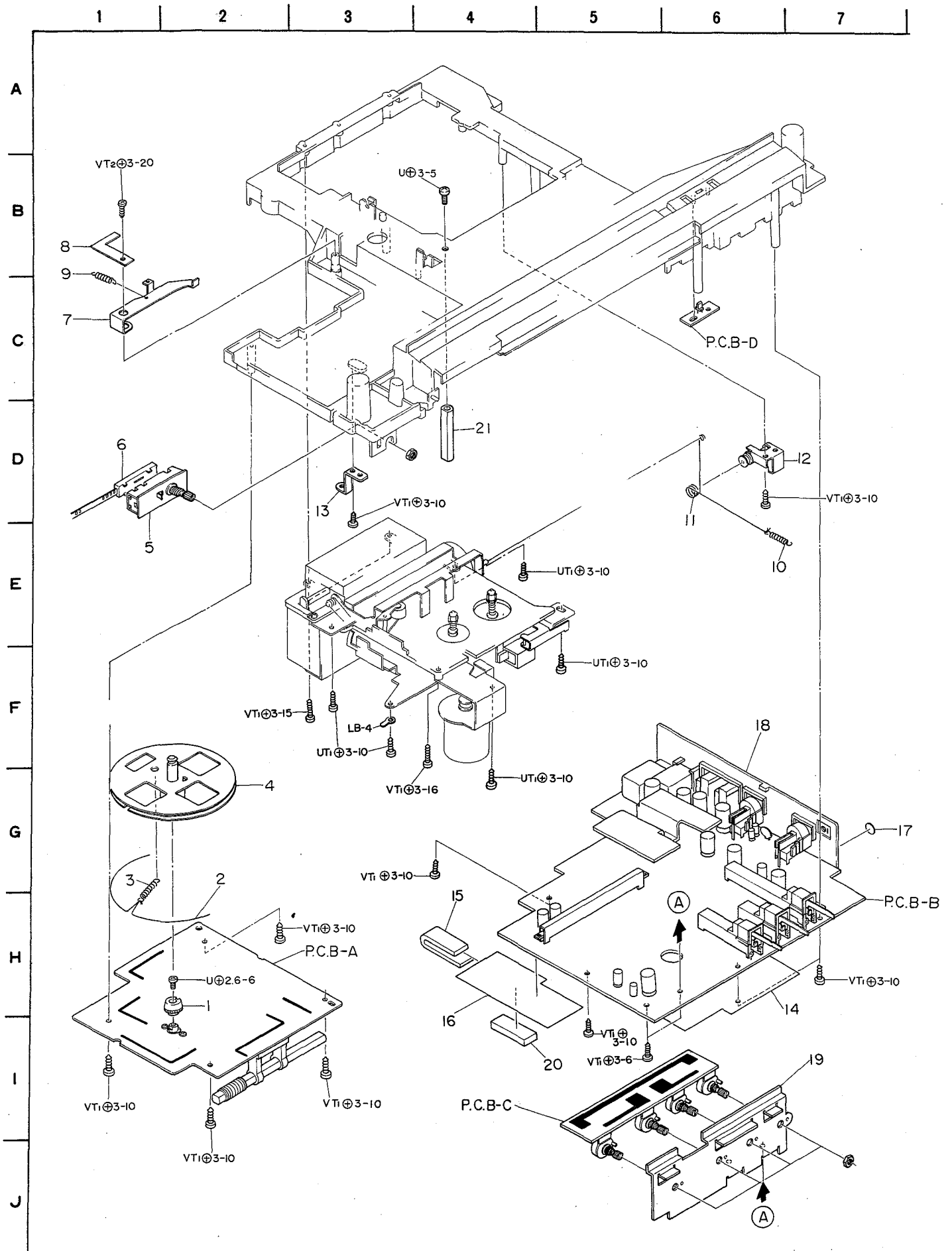

Ref. No.	Part No.	Part No. Changed to	Description	Common Model	Q'ty
3-1	82-439-311-01		Joint, Drum	TPR-300	1
3-2	87-096-048-01		String, Dial		1
3-3	82-541-291-01		E-spring, Dial		1
3-4	82-571-213-01		Dial drum	*	1
3-5	82-571-650-01		Control, Remote switch	*	1
3-6	82-563-651-01		Wire, Remote switch	TPR-990	1
3-7	82-571-225-01		Lever ass'y, Eject	*	1
3-8	82-571-243-01		Metal fitting L	*	1
3-9	82-571-230-01		E-spring, Eject lever	*	1
3-10	82-563-247-01		E-spring, Air-damp	TPR-990	1
3-11	87-096-045-01		String, Dial		1
3-12	87-078-003-01		Air-damp unit ass'y		1
3-13	82-571-250-01		Holder, P.C.B	*	1
3-14	82-571-649-01		Sield paper IC	*	1
3-15	82-563-280-01		Cushion, Battery room lid	TPR-990	1
3-16	82-563-647-01		Sield paper	TPR-990	1
3-17	82-571-040-01		Name plate	*	1
3-18	82-571-637-01		Jack plate ass'y	*	1
3-19	82-571-222-01		Holder, Volume	*	1
3-20	82-416-260-01		M cushion	TPR-601	1
3-21	82-571-251-01		Shaft, Motor cap		1

EXPLODED VIEW-4

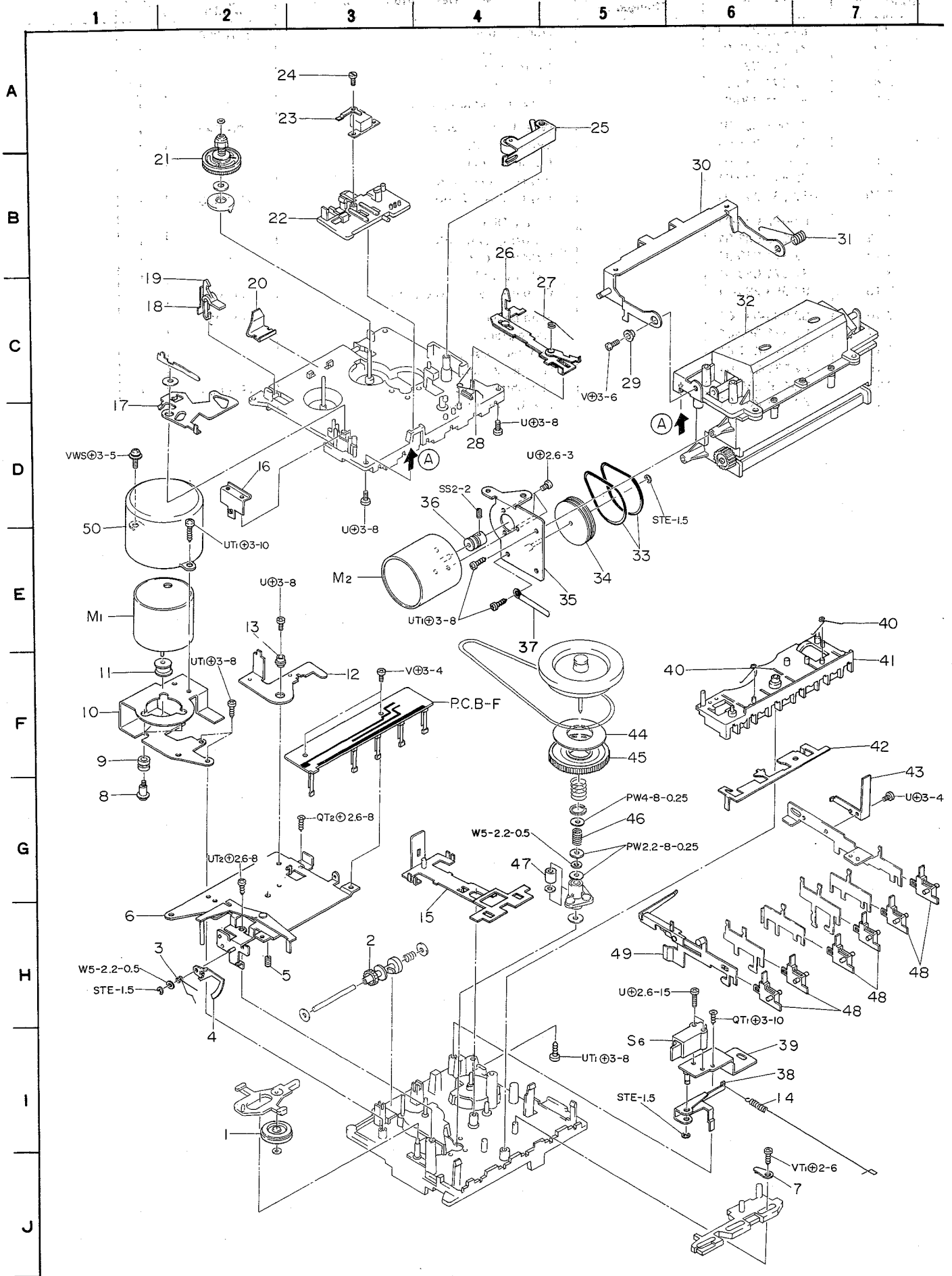

Ref. No.	Part No.	Part No. Changed to	Description	Common Model	Q'ty
4-1	82-439-463-01		PIAY idler ass'y	TPR-300	1
4-2	82-439-408-01		Warm wheel L ass'y	TPR-300	1
4-3	82-534-270-01		T-spring, PAUSE		1
4-4	82-534-275-01		Lock plate, Stand-by		1
4-5	82-385-311-01		Thrust for screw	AD-6300	1
4-6	82-562-220-01		Flywheel bearing plate ass.y	TPR-926	1
4-7	82-564-246-01		P-spring, FR		1
4-8	87-087-029-01		Rubber cushion		3
4-9	87-081-483-01		Motor screw, M2.6		3
4-10	82-562-202-01		Holder, Motor	TPR-926A	1
4-11	87-071-025-01		Motor, Pulley		1
4-12	82-571-221-01		Lever, REC	*	1
4-13	82-534-212-01		Collar, REC lever		1
4-14	82-563-212-01		E-spring, REC blocking	TPR-990	1
4-15	82-439-269-01		Brake plate	TPR-300	1
4-16	82-541-284-01		Plate spring, Wire holder	TPR-950	1
4-17	82-563-228-01		REC lock lever	TPR-990	1
4-18	82-563-278-01		P-spring, REC blocking	TPR-990	1
4-19	82-439-495-01		REC blocking lever	TPR-300	1
4-20	82-563-292-01		P-spring, Cassette hold	TPR-990	1
4-21	82-439-576-01		Take-up reel platform ass'y	TPR-300	1
4-22	82-439-561-01		Moving chassis	TPR-300	1
4-23	82-539-206-01		EH, Earth plate	TPR-905	1
4-24	87-081-862-01		REC/PB head adjuster screw		1
4-25	82-439-422-01		Pinch lever ass'y	TPR-300	1
4-26	82-571-236-01		Slide plate eject ass'y	*	1
4-27	82-571-231-01		T-spring, Eject	*	1
4-28	82-563-249-01		T-spring, Lever cassette-up	TPR-990	1
4-29	82-563-238-01		Collar, Cassette box	TPR-990	1
4-30	82-571-216-01		Lever ass'y, Cassette box	*	1
4-31	82-541-307-01		T-spring, Cassette box	TPR-950	1
4-32	09-017-683-01		MD-1 mechanism ass'y	*	1
4-33	82-564-244-01		Rubber belt		2
4-34	82-564-224-01		Gear B		1
4-35	82-564-203-01		Motor holder ass'y		1
4-36	82-564-227-01		Gear, Motor		1
4-37	87-038-039-01		Wire binder		1
4-38	82-563-258-01		Lever, REC blocking A	TPR-990	1
4-39	82-563-261-01		Holder, Power switch	TPR-990	1
4-40	82-439-469-01		Push-button spring A, R	TPR-300	2
4-41	82-439-466-01		Back plate	TPR-300	1
4-42	82-563-229-01		Slide plate B	TPR-990	1
4-43	82-534-298-01		REC plate spring, A		1
4-44	82-439-389-01		Felt, 24-30	TPR-300	1
4-45	82-439-355-01		Slip gear	TPR-300	1
4-46	82-563-290-01		E-spring, Flywheel		1
4-47	82-439-462-01		Rubber, Drive	TPR-300	1
4-48	82-564-234-01		Cover, Push-button		6
4-49	82-551-244-01		Pause lever ass'y	TPR-935	1
4-50	82-541-612-21		Shield cap, Motor		1

The following is the part number list of the **** marked parts of the PM-1 mechanism.

Ref. No.	Part No.	Description	Q'ty	Ref. No.	Part No.	Description	Q'ty
1-13	82-385-332-11	Spring B, Head adjusting	1	2-49	82-562-227-01	Main belt	1
1-14	87-046-159-01	Rec./Pb head	1	2-50	82-439-496-01	Flywheel ass'y	1
1-31	87-046-183-01	Erase head	1	2-51	82-385-314-21	Rubber belt	1
2-33	82-439-228-31	REC lever	1	2-60	82-385-309-21	Worm gear B ass'y	1

EXPLODED VIEW-5

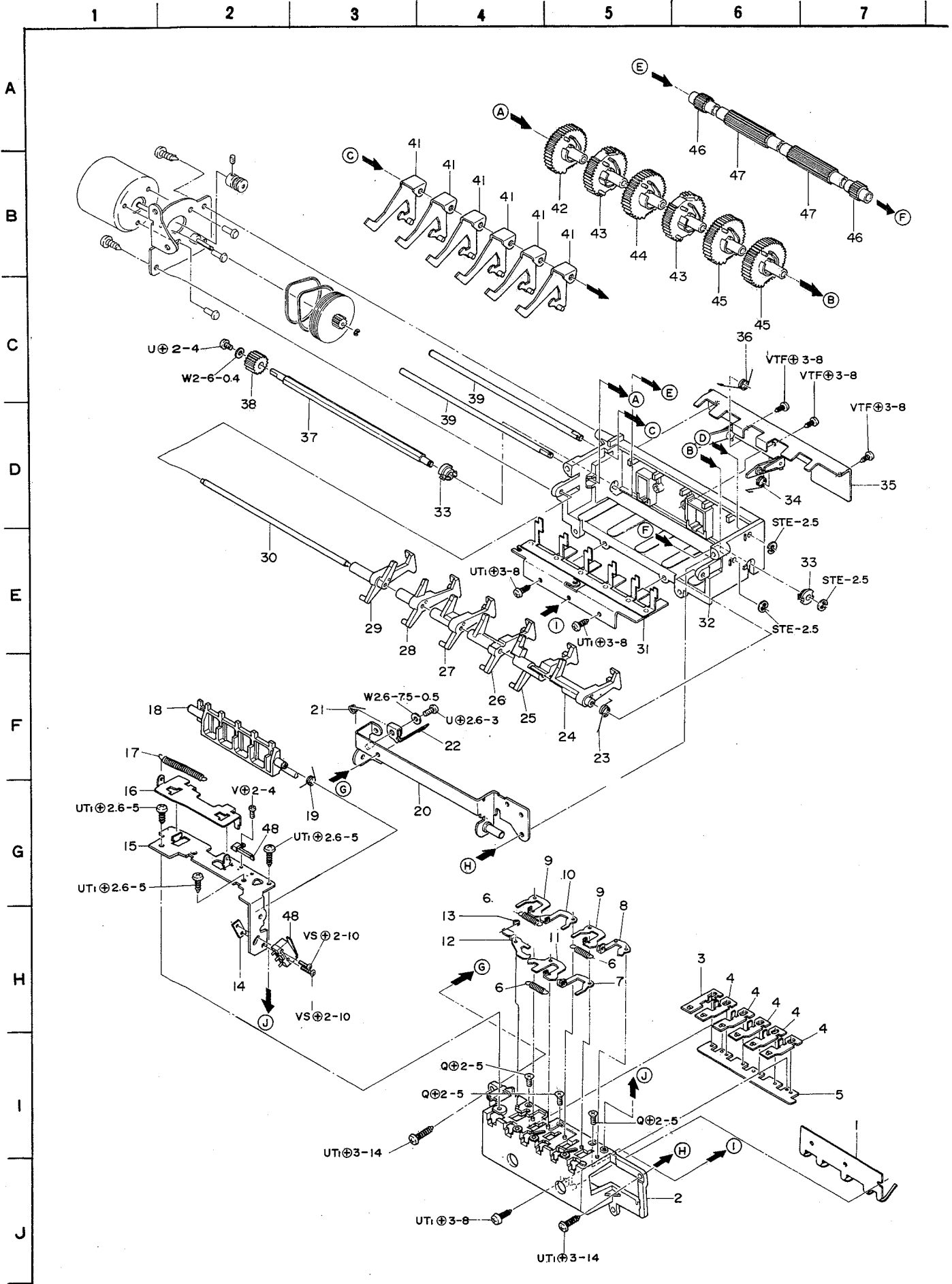

PARTS LIST

MD-1 MECHANICAL PARTS

■ *mark in this part list shows exclusive part (which is used) for only MD-1 mechanism.

Ref. No.	Part No.	Part No. Changed to	Description	Common Model	Q'ty
			MD-1 mechanism ass'y		1
1	82-564-260-01		P-spring, Lever stopper	*	1
2	82-564-202-01		Mechanism frame	*	1
3	82-564-243-01		Plate, Push-button E	*	1
4	82-564-242-01		Plate, Push-button D	*	5
5	82-564-255-01		Plate, Slide lever holder	*	1
6	82-564-262-01		E-spring, Anti-misoperation lever	*	3
7	82-564-276-01		Anti-misoperation lever A ass'y	*	1
8	82-564-274-01		Anti-misoperation lever ass'y	*	1
9	82-564-231-01		Lever, Anti-misoperation A	*	2
10	82-564-232-01		Lever, Anti-misoperation B	*	1
11	82-564-268-01		Lever, Anti-misoperation C	*	1
12	82-564-273-01		Lever, Anti-misoperation F	*	1
13	82-564-271-01		T-spring, Anti-misoperation	*	1
14	82-564-256-01		Plate nut	*	1
15	82-564-237-01		Holder, Switch	*	1
16	82-564-249-01		Slide plate, FR	*	1
17	82-564-264-01		E-spring, Lever FR	*	1
18	82-564-235-01		Lever-switch	*	1
19	82-564-263-01		T-spring, Lever switch	*	1
20	82-563-222-01		Holder, Cassette arm ass'y	TPR-990	1
21	82-563-260-11		T-spring, REC blocking	TPR-990	1
22	82-563-259-01		Lever B, REC blocking	TPR-990	1
23	82-564-261-01		T-spring, Lever stopper	*	1
24	82-564-221-01		Lever, PAUSE gear stopper	*	1
25	82-564-220-01		Lever, STOP gear stopper	*	1
26	82-564-219-01		Lever, FF gear stopper	*	1
27	82-564-218-01		Lever, Play gear stopper	*	1
28	82-564-217-01		Lever, REW gear stopper	*	1
29	82-564-216-01		Lever, REC gear stopper	*	1
30	82-564-240-01		Shaft, Gear stopper	*	1
31	82-564-258-01		Holder (R-P) ass'y	*	1
32	82-564-201-01		Mechanism frame A	*	1
33	82-564-236-01		Shaft bearing	*	2
34	82-564-267-01		T-spring, REV lock B	*	1
35	82-564-208-01		T-spring, REV lock A	*	1
36	82-564-266-01		T-spring, REV lock A	*	1
37	82-564-239-01		Shaft, Gear C	*	1
38	82-564-224-01		Gear B	*	1
39	82-564-241-01		Shaft, Gear PLAY	*	2
40	87-031-537-01		Micro switch, S5		1
41	82-564-225-01		Lever push button ass'y	*	6
42	82-564-253-01		Gear, REC	*	1
43	82-564-214-01		Gear, FR	*	2
44	82-564-213-01		Gear, PLAY	*	1
45	82-564-252-01		Gear, STOP	*	2
46	82-564-247-01		Gear D	*	2
47	82-564-228-01		Gear C	*	2
48	87-031-393-01		Leaf switch,		1

ACCESSORIES/PACKAGE

Ref. No.	Part No.	Part No. Changed to	Description	Common Model	Q'ty
1	82-571-855-01		Printed indiv., Packing	*	1
2	82-571-852-01		Cushion L, Printed indiv.	*	1
3	82-571-853-01		Cushion R, Printed indiv.	*	1
4	87-051-137-11		Poly-vinyl sack (for AC power cord)		1
5	87-056-615-01		Poly-vinyl sack (for case)		1
6a	82-571-908-01		Instructions booklet (E model only)	*	1
6b	82-571-909-01		Instructions booklet (K model only)	*	1
7	82-571-905-01		Label, POP	*	1
8	87-051-171-11		Poly-vinyl sack (for instruction)		1
9	87-056-009-41		Distributors list (H model only)		1
10	82-916-670-01		Tape cassette, DMC-157		1
11	87-034-883-01		AC power cord (E model only)		1
12a	87-034-871-01		AC power cord (K model only)		1
12b	87-056-008-11		Label, AC power cord (K model only)		1
13	87-056-016-01		Tag Main voltage (K model only)		1

A
B
C
D
E
F
G
H
I
J

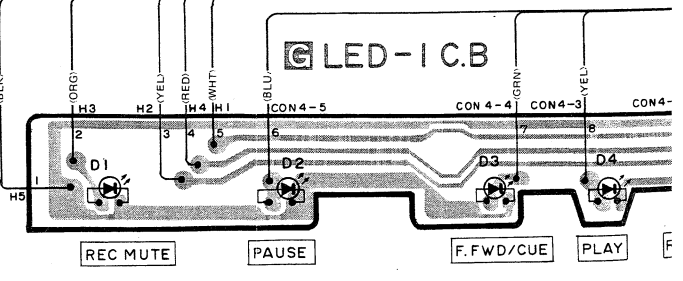
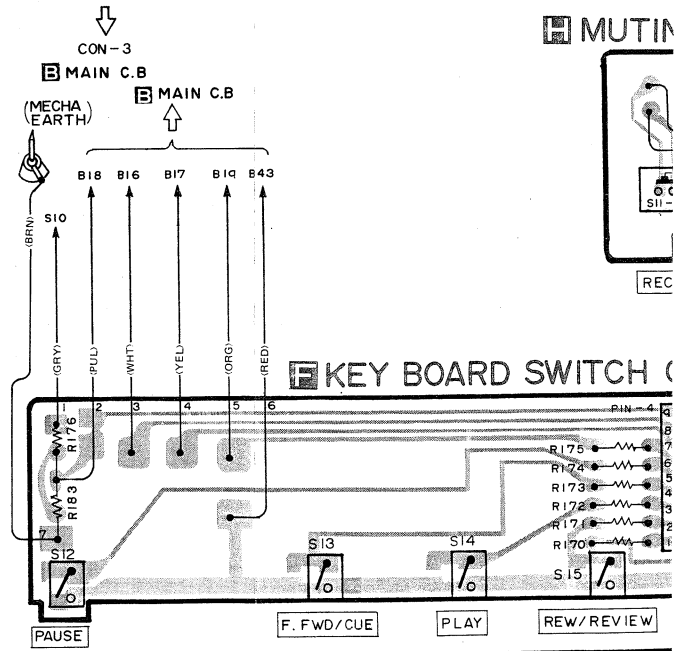
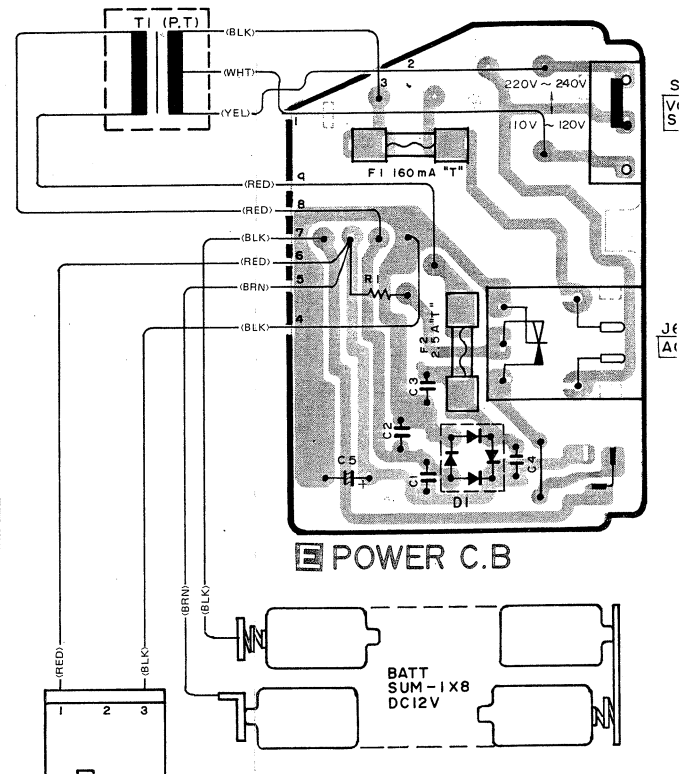
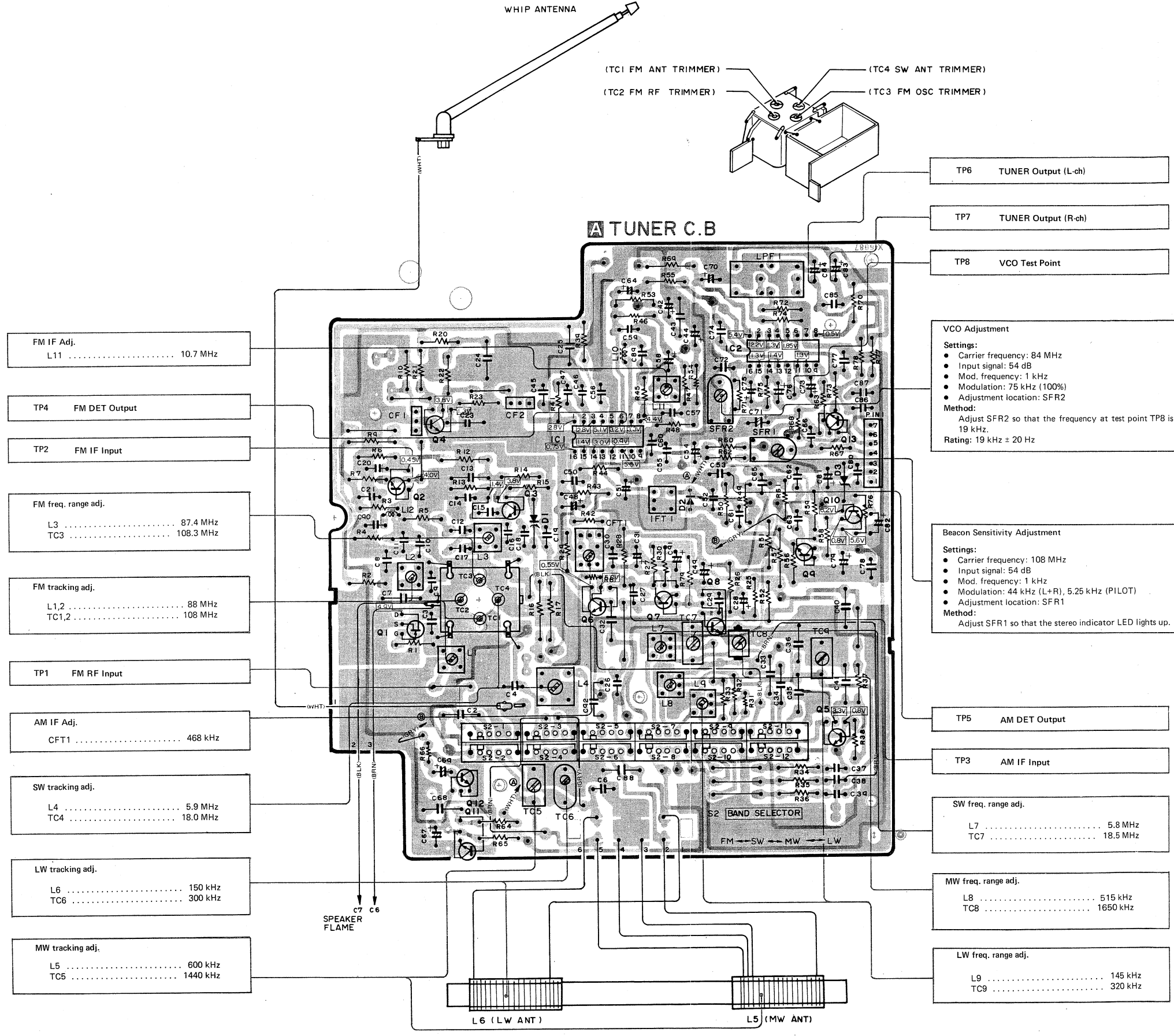

NOTES (1) B(+) Pattern Component side pattern Others pattern
 (2) The voltage is the reference value measured with a tester (20 K ohms/V DC) when there are no signals.
 But () is with AM reception.

WHIP ANTENNA

(TC1 FM ANT TRIMMER) (TC4 SW ANT TRIMMER)
 (TC2 FM RF TRIMMER) (TC3 FM OSC TRIMMER)

A TUNER C.B

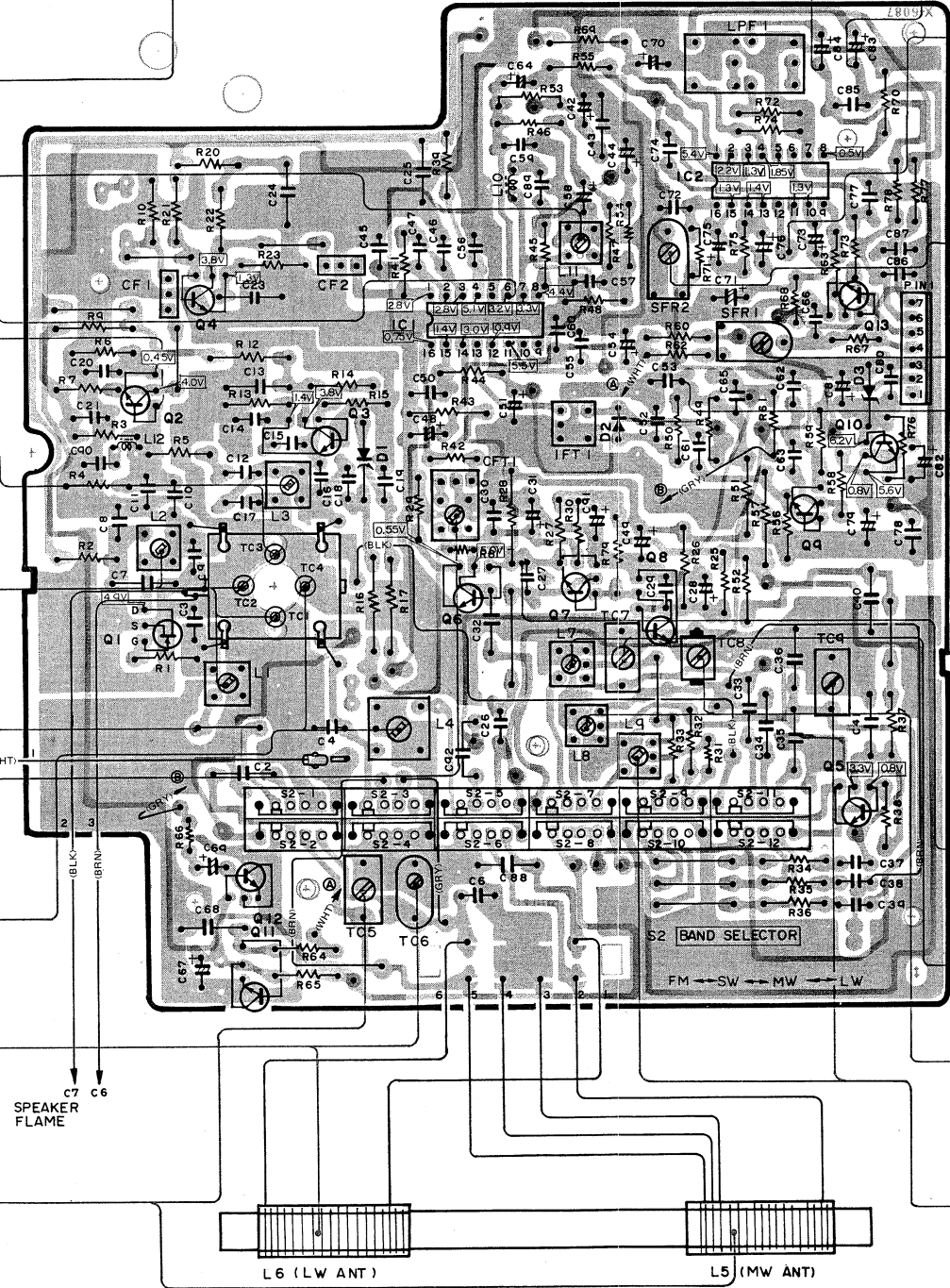

- TP6 TUNER Output (L-ch)
- TP7 TUNER Output (R-ch)
- TP8 VCO Test Point

VCO Adjustment

Settings:

- Carrier frequency: 84 MHz
- Input signal: 54 dB
- Mod. frequency: 1 kHz
- Modulation: 75 kHz (100%)
- Adjustment location: SFR2

Method:

Adjust SFR2 so that the frequency at test point TP8 is 19 kHz.

Rating: 19 kHz ± 20 Hz

Beacon Sensitivity Adjustment

Settings:

- Carrier frequency: 108 MHz
- Input signal: 54 dB
- Mod. frequency: 1 kHz
- Modulation: 44 kHz (L+R), 5.25 kHz (PILOT)
- Adjustment location: SFR1

Method:

Adjust SFR1 so that the stereo indicator LED lights up.

- TP5 AM DET Output
 - TP3 AM IF Input
- SW freq. range adj.
- L7 5.8 MHz
 TC7 18.5 MHz
- MW freq. range adj.
- L8 515 kHz
 TC8 1650 kHz
- LW freq. range adj.
- L9 145 kHz
 TC9 320 kHz

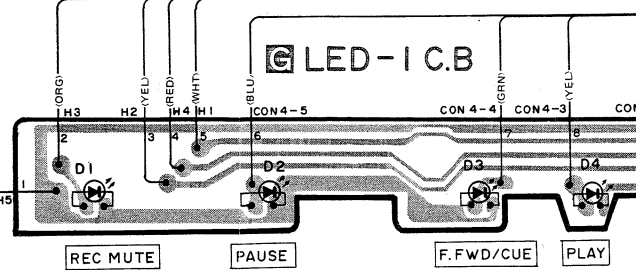
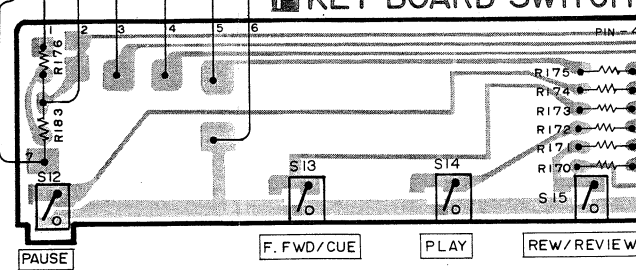
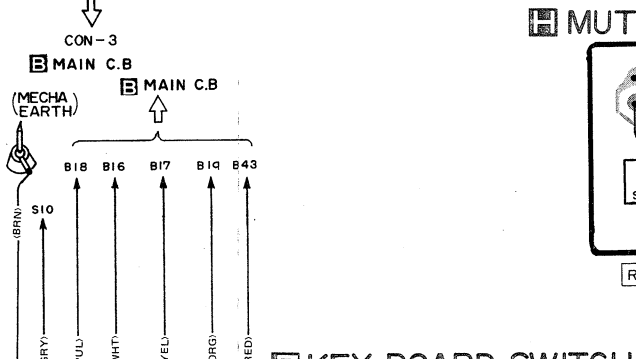
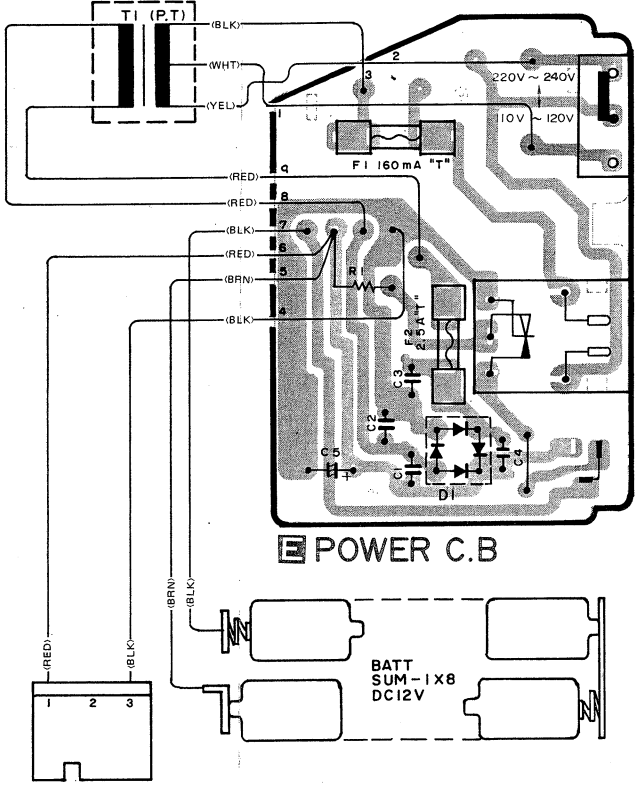

S14 VOLTAGE SELECTOR

J6 AC

POWER C.B

MUTING C.B

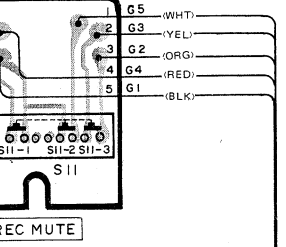

NOTES (1) B(+) Pattern Component side pattern Others pattern
 (2) The voltage is the reference value measured with a tester (20 K ohms/V DC) when there are no signals. But () is with AM reception.

WITING-2

1 2 3 4 5 6 7 8 9 10 11 12 13 14 15 16

A
B
C
D
E
F
G
H
I
J

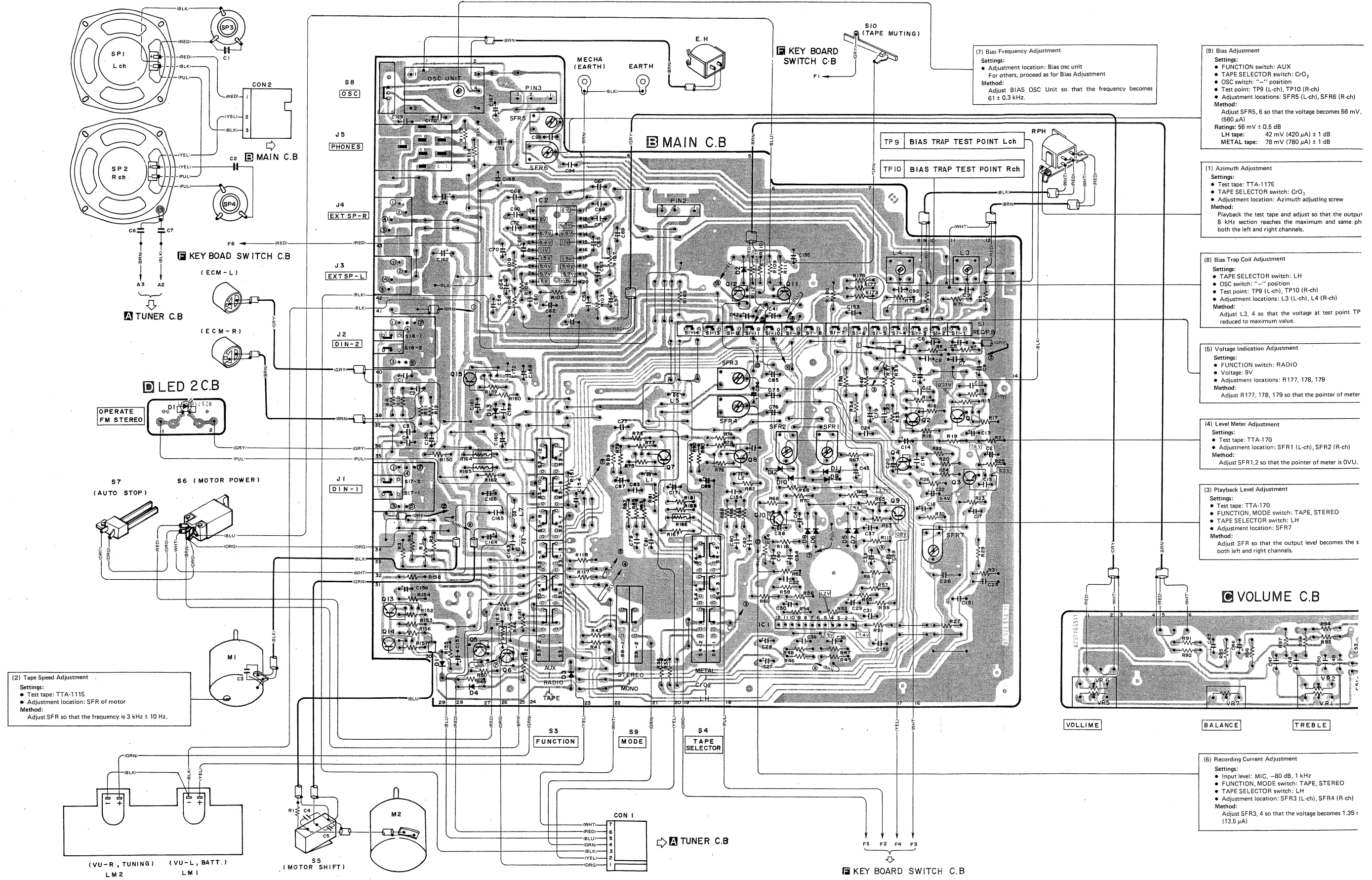

(2) Tape Speed Adjustment
 Settings:
 • Test tape: TTA-111S
 • Adjustment location: SFR of motor
 Method:
 Adjust SFR so that the frequency is 3 kHz \pm 10 Hz.

(7) Bias Frequency Adjustment
 Settings:
 • Adjustment location: Bias osc unit
 For others, proceed as for Bias Adjustment
 Method:
 Adjust BIAS OSC Unit so that the frequency becomes 61 \pm 0.3 kHz.

(9) Bias Adjustment
 Settings:
 • FUNCTION switch: AUX
 • TAPE SELECTOR switch: CrO₂
 • OSC switch: "—" position
 • Test point: TP9 (L-ch), TP10 (R-ch)
 • Adjustment locations: SFR5 (L-ch), SFR6 (R-ch)
 Method:
 Adjust SFR5, 6 so that the voltage becomes 56 mV (560 μ A)
 Ratings: 56 mV \pm 0.5 dB
 LH tape: 42 mV (420 μ A) \pm 1 dB
 METAL tape: 78 mV (780 μ A) \pm 1 dB

(1) Azimuth Adjustment
 Settings:
 • Test tape: TTA-117E
 • TAPE SELECTOR switch: CrO₂
 • Adjustment location: Azimuth adjusting screw
 Method:
 Playback the test tape and adjust so that the output 8 kHz section reaches the maximum and same ph both the left and right channels.

(8) Bias Trap Coil Adjustment
 Settings:
 • TAPE SELECTOR switch: LH
 • OSC switch: "—" position
 • Test point: TP9 (L-ch), TP10 (R-ch)
 • Adjustment locations: L3 (L-ch), L4 (R-ch)
 Method:
 Adjust L3, 4 so that the voltage at test point TP reduced to maximum value.

(5) Voltage Indication Adjustment
 Settings:
 • FUNCTION switch: RADIO
 • Voltage: 9V
 • Adjustment locations: R177, 178, 179
 Method:
 Adjust R177, 178, 179 so that the pointer of meter

(4) Level Meter Adjustment
 Settings:
 • Test tape: TTA-170
 • Adjustment location: SFR1 (L-ch), SFR2 (R-ch)
 Method:
 Adjust SFR1,2 so that the pointer of meter is 0VU.

(3) Playback Level Adjustment
 Settings:
 • Test tape: TTA-170
 • FUNCTION, MODE switch: TAPE, STEREO
 • TAPE SELECTOR switch: LH
 • Adjustment location: SFR7
 Method:
 Adjust SFR so that the output level becomes the s both left and right channels.

(6) Recording Current Adjustment
 Settings:
 • Input level: MIC, -80 dB, 1 kHz
 • FUNCTION, MODE switch: TAPE, STEREO
 • TAPE SELECTOR switch: LH
 • Adjustment location: SFR3 (L-ch), SFR4 (R-ch)
 Method:
 Adjust SFR3, 4 so that the voltage becomes 1.35 μ A (13.5 μ A)

NOTES (1) B(+) Pattern Others pattern
 (2) The voltage is the reference value measured with a tester (20 K ohms/V DC) when there are no signals. An asterisk (*) indicates that the value was measured with a vacuum-tube voltmeter during recording.

4 5 6 7 8 9 10 11 12 13 14 15 16 17 18

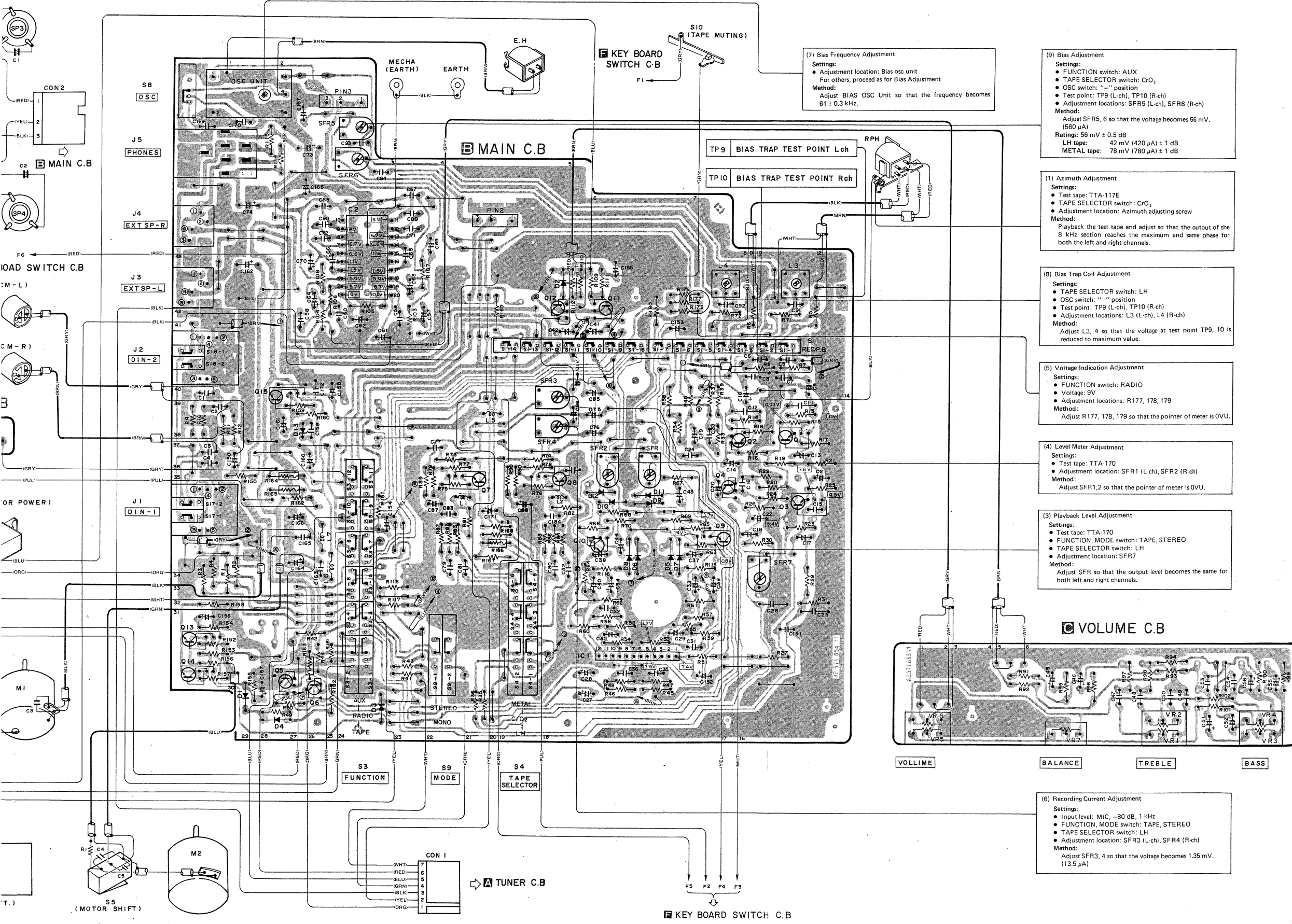

(7) Bias Frequency Adjustment
 Settings:
 • Adjustment location: Bias osc unit
 For others, proceed as for Bias Adjustment
 Method:
 Adjust BIAS OSC Unit so that the frequency becomes 61 ± 0.3 kHz.

(9) Bias Adjustment
 Settings:
 • FUNCTION switch: AUX
 • TAPE SELECTOR switch: CrO₂
 • OSC switch: "-" position
 • Test point: TP9 (L-ch), TP10 (R-ch)
 • Adjustment locations: SFR5 (L-ch), SFR6 (R-ch)
 Method:
 Adjust SFR5, 6 so that the voltage becomes 56 mV. (560 μ A)
 Ratings: 56 mV \pm 0.5 dB
 LH tape: 42 mV (420 μ A) \pm 1 dB
 METAL tape: 78 mV (780 μ A) \pm 1 dB

(1) Azimuth Adjustment
 Settings:
 • Test tape: TTA-117E
 • TAPE SELECTOR switch: CrO₂
 • Adjustment location: Azimuth adjusting screw
 Method:
 Playback the test tape and adjust so that the output of the 8 kHz section reaches the maximum and same phase for both the left and right channels.

(8) Bias Trap Coil Adjustment
 Settings:
 • TAPE SELECTOR switch: LH
 • OSC switch: "-" position
 • Test point: TP9 (L-ch), TP10 (R-ch)
 • Adjustment locations: L3 (L-ch), L4 (R-ch)
 Method:
 Adjust L3, 4 so that the voltage at test point TP9, 10 is reduced to maximum value.

(5) Voltage Indication Adjustment
 Settings:
 • FUNCTION switch: RADIO
 • Voltage: 9V
 • Adjustment locations: R177, 178, 179
 Method:
 Adjust R177, 178, 179 so that the pointer of meter is 0VU.

(4) Level Meter Adjustment
 Settings:
 • Test tape: TTA-170
 • Adjustment location: SFR1 (L-ch), SFR2 (R-ch)
 Method:
 Adjust SFR1,2 so that the pointer of meter is 0VU.

(3) Playback Level Adjustment
 Settings:
 • Test tape: TTA-170
 • FUNCTION, MODE switch: TAPE, STEREO
 • TAPE SELECTOR switch: LH
 • Adjustment location: SFR7
 Method:
 Adjust SFR so that the output level becomes the same for both left and right channels.

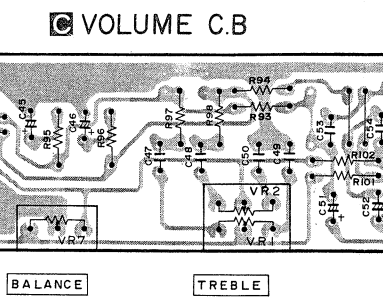

(6) Recording Current Adjustment
 Settings:
 • Input level: MIC, -80 dB, 1 kHz
 • FUNCTION, MODE switch: TAPE, STEREO
 • TAPE SELECTOR switch: LH
 • Adjustment location: SFR3 (L-ch), SFR4 (R-ch)
 Method:
 Adjust SFR3, 4 so that the voltage becomes 1.35 mV. (13.5 μ A)

NOTES (1) B(+) Pattern Others pattern
 (2) The voltage is the reference value measured with a tester (20 K ohms/V DC) when there are no signals. An asterisk (*) indicates that the value was measured with a vacuum-tube voltmeter during recording.

ELECTRICAL MAIN PARTS LIST

Symbol No.	Part No.	Description
« TUNER CIRCUIT BOARD SECTION »		
PCB-A	82-563-682-11	Tuner circuit board
IC1	87-027-285-01	IC, HA-11251
IC2	87-027-430-11	IC, LA-3361
Q1	87-026-107-01	FET, 2SK49F1
Q2,3,4,6	89-319-233-01	Transistor, 2SC1923(O)
Q5	89-319-232-01	Transistor, 2SC1923(R)
Q7,8	89-318-155-01	Transistor, 2SC1815(GR)
Q9,13	89-309-455-01	Transistor, 2SC945L(Q)
Q10	89-404-673-01	Transistor, 2SD467(C)
Q11,12	89-318-154-01	Transistor, 2SC1815(Y)
D1	87-017-004-01	Diode, SD117
D2	88-052-188-11	Diode, 1S188(FM)
D3	87-027-431-01	Zener diode, RD6.2EB2
L1	82-551-675-01	FM antenna coil
L2	87-006-017-01	FM coil, 2½t
L3	87-007-088-01	FM OSC coil, 2½t
L4	82-551-679-01	SW antenna coil
L5,6	82-563-669-01	MW/LW bar antenna coil
L7	82-563-665-01	SW OSC coil
L8	82-563-663-01	MW OSC coil
L9	82-563-664-01	LW OSC coil
L10	87-005-134-01	Coil
L11	87-008-209-01	Quad coil
L12	87-005-101-01	FM choke coil, 2.2µH
VC1~5	82-563-678-11	PVC
TC1~4		
TC5,7,8	87-011-099-01	Trimmer
TC6,9	87-011-088-01	Trimmer
CF1,2	87-008-169-01	Ceramic filter
CFT1	82-494-786-01	Ceramic filter transformer
IFT1	87-008-187-01	AM IFT
LPF1	87-030-070-01	Low pass filter
S2	82-563-661-01	Remote switch (BAND SELECTOR)
S25	82-541-644-01	Push switch (AFC)
SFR1	87-021-570-01	Semi-fixed resistor, 100kΩ-B
SFR2	87-021-566-01	Semi-fixed resistor, 5kΩ-B
PIN-1	87-032-907-01	Pin, 7P
< Capacitors >		
C73,76	87-015-321-01	0.47µF 10V Aluminum solid
C75	87-015-425-01	1µF 10V Aluminum solid
C72	87-014-057-01	1000pF PP
« MAIN CIRCUIT BOARD SECTION »		
PCB-B	82-571-654-01	Main circuit board
IC1	87-027-621-01	IC, TA7328A
IC2	87-027-533-11	IC, TA7229P
Q1,2	89-322-406-01	Transistor, 2SC2240(BL)
Q3,4	89-307-325-01	Transistor 2SC732(G)
Q5,6,7,8 9,10,11,12 13,14	89-318-154-01	Transistor, 2SC1815(Y)
Q15	89-318-464-01	Transistor, 2SC1846(R)
D1,2,3,4	88-052-188-11	Diode, 1S188(FM)
D5,6,7,8,10, 11,12,13	87-027-097-01	Diode, 1S1555
D9	87-027-241-01	Zener diode, 05Z9 1L
L1,2	87-005-088-01	Micro inductor coil, 5.6mH
L3,4	87-008-173-01	Bias trap coil
L5	82-401-661-01	Choke coil, 600µH
L6,7	87-003-039-01	Choke coil, 36µH

Symbol No.	Part No.	Description
BIAS OSC UNIT	82-570-639-01	Bias OSC unit
J1,2	87-032-741-01	DIN jack, 5P w/switch (DIN 1,2)
J3,4	87-032-742-01	DIN jack, 2P w/switch (EXT-SP)
J5	82-571-652-01	Jack plate ass'y (PHONES)
S1	82-562-604-01	Slide switch (REC/PB)
S3	82-571-613-01	Slide lever switch (FUNCTION)
S4	82-517-642-01	Slide lever switch (TAPE SELECTOR)
S8	82-431-604-01	Slide switch (OSC)
S9	82-571-612-01	Slide lever switch (MODE)
SFR1,2,7	87-021-568-01	Semi-fixed resistor, 20kΩ-B
SFR3,4	87-021-569-01	Semi-fixed resistor, 50kΩ-B
SFR5,6	87-021-570-01	Semi-fixed resistor, 100kΩ-B
PIN2,3	87-032-991-01	Pin, 3P
< Resistors >		
R166	87-029-015-01	10Ω ¼w Fuse resistor
R163	87-029-060-01	33Ω ¼w Fuse resistor
R165,169	87-029-108-01	1Ω ¼w Fuse resistor
< Capacitors >		
C168	87-015-480-01	220µF 16V Electrolytic
C158,161,166	87-015-477-01	470µF 16V Electrolytic
C164	87-015-559-01	1000µF 16V Electrolytic
C73,74,162	87-015-530-01	2200µF 16V Electrolytic
C160,171	87-015-660-01	470µF 10V Electrolytic
C91,92	87-014-051-01	560pF PP
C7,8	87-014-055-01	820pF PP
C41,42,87	87-015-421-01	0.22µF 25V Aluminum solid
88		
C57,58	87-015-425-01	1µF 25V Aluminum solid
« VOLUME CIRCUIT BOARD SECTION »		
PCB-C	82-571-655-01	Volume circuit board
VR1,2,3,4	82-571-603-01	Volume, 50kΩ-A (TREBLE, BASS)
VR5,6	82-571-604-01	Volume, 20kΩ-A (VOLUME)
VR7	82-571-605-01	Volume, 100kΩ-W (BALANCE)
	87-032-981-01	Wire post
< Capacitors >		
C51,52,55,56	87-015-427-01	0.15µF 25V Aluminum solid
C45,46	87-015-421-01	0.22µF 25V Aluminum solid
« LED-2 CIRCUIT BOARD SECTION »		
PCB-D	82-571-656-01	LED-2 circuit board
D1	87-027-542-01	LED, LN217RP
« POWER CIRCUIT BOARD SECTION »		
PCB-E	82-551-672-21	Power circuit board
D14	87-027-609-01	Encapsulated diode
J10	87-049-010-01	AC jack
S17	87-031-466-01	Slide switch (VOLTAGE SELECTOR)
F1	87-035-080-01	Fuse, "T" 160mA
F2	87-035-177-01	Fuse, 2.5A
	87-098-199-01	Fuse label, 2.5A
	87-033-147-01	Fuse clamp

Symbol No.	Part No.	Description
R201	87-025-194-01	< Resistor > 220Ω 2w Metal film resistor
« KEY BOARD SWITCH CIRCUIT BOARD SECTION »		
PCB-F	82-517-631-31	Key board switch circuit board
S12,13,14,15, 16	87-031-538-01	Leaf switch (PAUSE, F. FWD/ CUE, PLAY, REW/REVIEW, RECORD)
PIN-4	87-032-919-01	Pin, 9P
« LED-1 CIRCUIT BOARD SECTION »		
PCB-G	82-571-626-11	LED-1 circuit board
D1,2,3,5,6	82-561-614-01	LED, TLR-205
D4	87-027-612-01	LED, TLG-205
« MUTING CIRCUIT BOARD SECTION »		
PCB-H	82-517-628-01	Muting circuit board
S11	87-031-532-01	Push-switch (REC MUTE)
« MISCELLANEOUS »		
T1	82-571-657-01	Power transformer (E model only)
T1	82-571-658-01	Power transformer (K model only)
RPH	87-046-159-01	REC/PB head
EH	87-046-183-01	Erase head
ECM1,2	87-041-018-01	ECM, WH-034AY
M1	87-045-135-01	Motor, DC-EG
M2	87-045-138-01	Motor, MD
LM1,2	82-571-610-01	Level meter
SP1,2	82-571-644-01	Speaker, Woofer
SP3,4	82-571-645-01	Speaker, Tweeter
S5	87-031-537-01	Micro switch (MOTOR SHIFT)
S6	87-031-493-01	Micro switch (MOTRO POWER)
S7	87-031-393-01	Leaf switch (AUTO STOP)
CON-2	82-571-643-01	Connector ass'y, 3P
CON-3	82-571-616-01	Connector ass'y, 3P
CON-1	82-571-648-01	Connector ass'y, 7P
CON-4	82-571-620-01	Connector ass'y, 9P
< Capacitor >		
C1,2	87-015-624-01	4.7µF 50V Electrolytic BP

⚠ This symbol is given to important parts which serve to maintain the safety of the product, and which are made to conform to special safety specifications. Therefore, when replacing a component with this symbol, make absolutely sure that you use a designated part.

Symbol No.	Part No.	Description
BIAS OSC UNIT	82-570-639-01	Bias OSC unit
J1,2	87-032-741-01	DIN jack, 5P w/switch (DIN 1,2)
J3,4	87-032-742-01	DIN jack, 2P w/switch (EXT-SP)
J5	82-571-652-01	Jack plate ass'y (PHONES)
S1	82-562-604-01	Slide switch (REC/PB)
S3	82-571-613-01	Slide lever switch (FUNCTION)
S4	82-517-642-01	Slide lever switch (TAPE SELECTOR)
S8	82-431-604-01	Slide switch (OSC)
S9	82-571-612-01	Slide lever switch (MODE)
SFR1,2,7	87-021-568-01	Semi-fixed resistor, 20kΩ-B
SFR3,4	87-021-569-01	Semi-fixed resistor, 50kΩ-B
SFR5,6	87-021-570-01	Semi-fixed resistor, 100kΩ-B
PIN2,3	87-032-991-01	Pin, 3P
< Resistors >		
△ R166	87-029-015-01	10Ω ¼w Fuse resistor
△ R163	87-029-060-01	33Ω ¼w Fuse resistor
△ R165,169	87-029-108-01	1Ω ½w Fuse resistor
< Capacitors >		
C168	87-015-480-01	220μF 16V Electrolytic
C158,161,166	87-015-477-01	470μF 16V Electrolytic
C164	87-015-559-01	1000μF 16V Electrolytic
C73,74,162	87-015-530-01	2200μF 16V Electrolytic
C160,171	87-015-660-01	470μF 10V Electrolytic
C91,92	87-014-051-01	560pF PP
C7,8	87-014-055-01	820pF PP
C41,42,87	87-015-421-01	0.22μF 25V Aluminum solid
88		
C57,58	87-015-425-01	1μF 25V Aluminum solid
< VOLUME CIRCUIT BOARD SECTION >		
PCB-C	82-571-655-01	Volume circuit board
VR1,2,3,4	82-571-603-01	Volume, 50kΩ-A (TREBLE, BASS)
VR5,6	82-571-604-01	Volume, 20kΩ-A (VOLUME)
VR7	82-571-605-01	Volume, 100kΩ-W (BALANCE)
	87-032-981-01	Wire post
< Capacitors >		
C51,52,55,56	87-015-427-01	0.15μF 25V Aluminum solid
C45,46	87-015-421-01	0.22μF 25V Aluminum solid
< LED-2 CIRCUIT BOARD SECTION >		
PCB-D	82-571-656-01	LED-2 circuit board
D1	87-027-542-01	LED, LN217RP
< POWER CIRCUIT BOARD SECTION >		
PCB-E	82-551-672-21	Power circuit board
D14	87-027-609-01	Encapsulated diode
△ J10	87-049-010-01	AC jack
△ S17	87-031-466-01	Slide switch (VOLTAGE SELECTOR)
△ F1	87-035-080-01	Fuse, "T" 160mA
△ F2	87-035-177-01	Fuse, 2.5A
	87-098-199-01	Fuse label, 2.5A
△	87-033-147-01	Fuse clamp

Symbol No.	Part No.	Description
		< Resistor >
R201	87-025-194-01	220Ω 2w Metal film resistor
<< KEY BOARD SWITCH CIRCUIT BOARD SECTION >>		
PCB-F	82-517-631-31	Key board switch circuit board
S12,13,14,15,16	87-031-538-01	Leaf switch (PAUSE, F. FWD/CUE, PLAY, REW/REVIEW, RECORD)
PIN-4	87-032-919-01	Pin, 9P
<< LED-1 CIRCUIT BOARD SECTION >>		
PCB-G	82-571-626-11	LED-1 circuit board
D1,2,3,5,6	82-561-614-01	LED, TLR-205
D4	87-027-612-01	LED, TLG-205
<< MUTING CIRCUIT BOARD SECTION >>		
PCB-H	82-517-628-01	Muting circuit board
S11	87-031-532-01	Push-switch (REC MUTE)
<< MISCELLANEOUS >>		
△ T1	82-571-657-01	Power transformer (E model only)
△ T1	82-571-658-01	Power transformer (K model only)
△ RPH	87-046-159-01	REC/PB head
EH	87-046-183-01	Erase head
ECM1,2	87-041-018-01	ECM, WH-034AY
M1	87-045-135-01	Motor, DC-EG
M2	87-045-138-01	Motor, MD
LM1,2	82-571-610-01	Level meter
SP1,2	82-571-644-01	Speaker, Woofer
SP3,4	82-571-645-01	Speaker, Tweeter
S5	87-031-537-01	Micro switch (MOTOR SHIFT)
S6	87-031-493-01	Micro switch (MOTRO POWER)
S7	87-031-393-01	Leaf switch (AUTO STOP)
CON-2	82-571-643-01	Connector ass'y, 3P
CON-3	82-571-616-01	Connector ass'y, 3P
CON-1	82-571-648-01	Connector ass'y, 7P
CON-4	82-571-620-01	Connector ass'y, 9P
< Capacitor >		
C1,2	87-015-624-01	4.7μF 50V Electrolytic BP

△ This symbol is given to important parts which serve to maintain the safety of the product, and which are made to conform to special safety specifications. Therefore, when replacing a component with this symbol, make absolutely sure that you use a designated part.

☆☆☆☆☆☆☆☆☆☆☆☆☆☆☆☆☆☆ MEMO ☆☆☆☆☆☆☆☆☆☆☆☆☆☆☆☆☆

SCHEMATIC DIAGRAM

1 2 3 4 5 6 7 8 9 10 11 12 13 14 15 16

A B C D E F G H I J

- S1 - 1-14 REC/P.B (PB)
- S2 - 1-12 BAND SELECTOR (FM)
- S3 - 1-12 FUNCTION (LINE)
- S4 - 1-6 TAPE SELECTOR (METAL)
- S5 MOTOR SHIFT
- S6 MOTOR POWER
- S7 AUTO STOP
- S8 OSC
- S9 MODE (STEREO)
- S10 TAPE MUTING
- S11 REC MUTE
- S12 PAUSE
- S13 F.FWD/CUE
- S14 PLAY
- S15 REW/REVIEW
- S16 RECORD
- S17 DIN-1
- S18 DIN-2
- S19 VOLTAGE SELECTOR (220 ~ 240V)

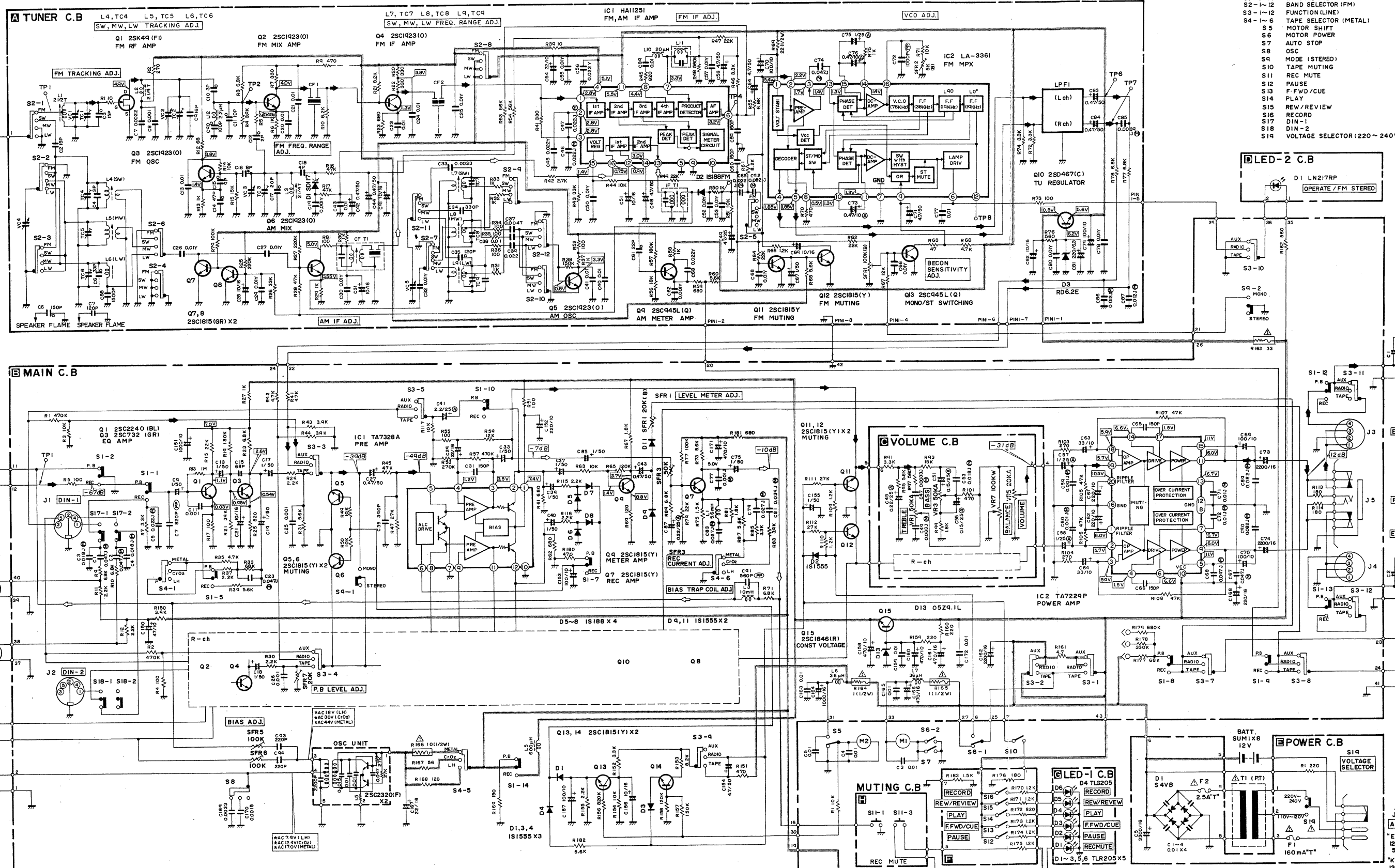

NOTES:

- 1) B (+) power supply
- 2) Signal path
- 3) The voltage is the reference value measured with a

- 4) Resistor with no designation have a rated power of 1/4W and a tolerance of ±5%.
- 5) Capacitors with no designation have a dielectric

- 6) The only capacitor tolerances indicated are ±5% (J) and ±10% (K).
- 7) Ceramic capacitor symbols:
 - For temperature compensation (SL)

- 8) Explanation of symbols
 - High dielectric constant system (YY)
 - High dielectric constant system (YW, YP, YZ)
 - Semiconductor ceramic

- PP Polypropylene film capacitor
- T Tantalum capacitor
- F Fuse resistor
- △ Safety component symbol

E model
120V/220V
50/60Hz

K model
120V/240V
50/60Hz

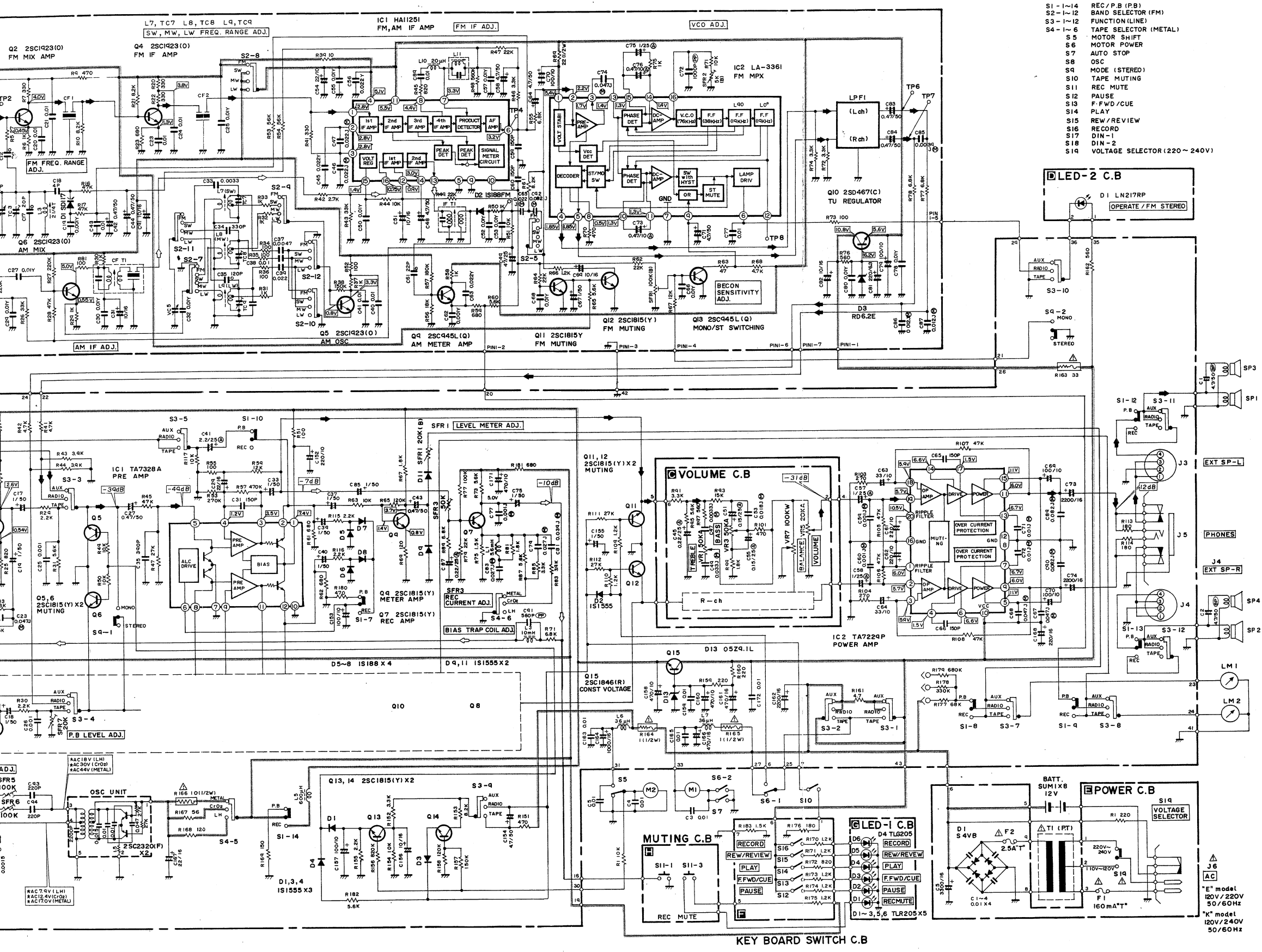

- S1 - I-14 REC/P.B (P.B)
- S2 - I-12 BAND SELECTOR (FM)
- S3 - I-12 FUNCTION (LINE)
- S4 - I-6 TAPE SELECTOR (METAL)
- S5 MOTOR SHIFT
- S6 MOTOR POWER
- S7 AUTO STOP
- S8 OSC
- S9 MODE (STEREO)
- S10 TAPE MUTING
- S11 REC MUTE
- S12 PAUSE
- S13 F.FWD/CUE
- S14 PLAY
- S15 REW/REVIEW
- S16 RECORD
- S17 DIN-1
- S18 DIN-2
- S19 VOLTAGE SELECTOR (220~240V)

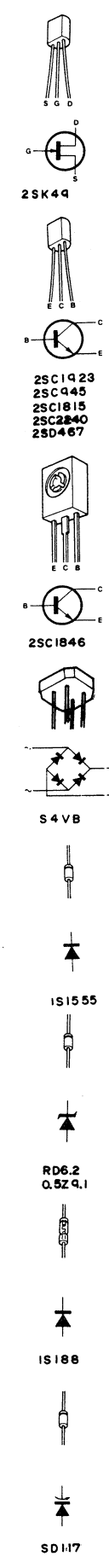

tester (20 k-ohms/V DC) when there are no signals. But () is with AM reception.

- 4) Resistors with no designation have a rated power of 1/4W and a tolerance of ±5%.
- 5) Capacitors with no designation have a dielectric

strength of less than 50WV.

- 6) The only capacitor tolerances indicated are ±5% (J) and ±10% (K).
- 7) Ceramic capacitor symbols:
 - For temperature compensation (SL)

- 8) Explanation of symbols
 - High dielectric constant system (YY)
 - High dielectric constant system (YW, YP, YZ)
 - Semiconductor ceramic
 - Mylar capacitor

- PP Polypropylene film capacitor
- T Tantalum capacitor
- Fuse resistor
- △ Safety component symbol

This symbol is given to important parts which serve

to maintain the safety of the product, and which are made to conform to special safety specifications. Therefore, when replacing a component with this symbol, make absolutely sure that you use a designated part.

This schematic diagram is subject to change without notice in the interests of improved performance.